

TRANSISTOR AS A RECTIFIER

RAJU BADDI

National Center for Radio Astrophysics, TIFR, Ganeshkhind P.O Bag 3, Pune University Campus,
PUNE 411007, Maharashtra, INDIA; baddi@ncra.tifr.res.in

ABSTRACT

Transistor is a three terminal semiconductor device normally used as an amplifier or as a switch. Here the alternating current(a.c) rectifying property of the transistor is considered. The ordinary silicon diode exhibits a voltage drop of $\sim 0.6V$ across its terminals. In this article it is shown that the transistor can be used to build a diode or rectify low current a.c($\sim mA$) with a voltage drop of $\sim 0.03V$. This voltage is ~ 20 times smaller than the silicon diode. The article gives the half-wave and full-wave transistor rectifier configurations along with some applications to justify their usefulness.

1. INTRODUCTION

Rectification of a.c is normally carried out using silicon diodes(Kasatkin & Nemtsov 1986). The silicon diode exhibits a voltage drop of $\sim 600mV$ across its terminals when forward biased. This $0.6V$ is very small voltage if one wants to rectify voltages like $10V$ or $100V$ and hence the voltage drop across the diode can be neglected. The diode for all practical purposes is considered to conduct freely in one direction and completely non-conducting in the other direction(reverse bias). However if one needs to rectify an a.c of amplitude $1V$, the $0.6V$ across the silicon diode forms a large fraction(60%). Essentially the silicon diode cannot be used to rectify low voltages like $1V$ a.c if one is interested in recovering the complete or almost complete(90%) waveform of the signal. In this article the possibility of using a transistor as a rectifier(Pookaiyaudom et.al) is explored. It is seen that the transistor rectifier exhibits a voltage drop of $0.03V$ or in other words it forms a diode with this voltage drop. This voltage is 20 times smaller compared to the silicon diode and 5 times smaller compared to the schottky diode($0.15V$). Thus the transistor rectifier can be used to rectify a.c as low as 10 times the voltage drop across it, $\sim 300mV$. This article gives half-wave and full-wave configurations of the transistor rectifier.

2. THE TRANSISTOR RECTIFIER

Rectification of alternating current with a single transistor has been considered. This simple circuit consisting of a transistor, a biasing diode and a few resistors can rectify a.c as low as $0.3V$ or even less. The rectification can be for positive half cycle or negative half cycle depending on the type of transistor(pnp/npn respectively) chosen. The schematic circuit of the rectifier is as shown in Fig-1. The quiescent forward biasing(Kasatkin & Nemtsov 1986) of the base-emitter junction of the transistor is taken care by the voltage drop across the silicon diode($1N4148$). The base-emitter junction of the silicon transistor and the silicon diode being similar the voltage drops across them are also more or less equal. The a.c to be rectified is introduced in the emitter circuit as shown in the Fig-1. Under this situation to the first order any low negative voltage(NPN-version) appearing at the emitter would set up an emitter current which would mostly flow to the collector. However a small voltage drop($\sim 0.03V$) across collector and emitter of the transistor is required to maintain a current through it. Essentially any additional voltage in the base-emitter loop other than the balanced out voltage drops of the silicon diode and the base-emitter junction will be transferred to the collector circuit, as most of the emitter current flows through the collector. The Fig-1 shows

both types of rectifiers which can rectify either the negative phase or the positive phase of the a.c signal. A full wave bridge rectifier using four transistors is shown in Fig-2. The results of computer simulation in **Linux Qucs** are shown in Fig-3,4. During the opposite phase i.e positive voltage w.r.t ground for NPN-version the base-emitter junction would be reverse biased however the base-collector junction is forward biased with the voltage drop across the biasing diode which is insufficient to setup a current through R_L . Thus the circuit behaves as a rectifier passing only one phase of the a.c.

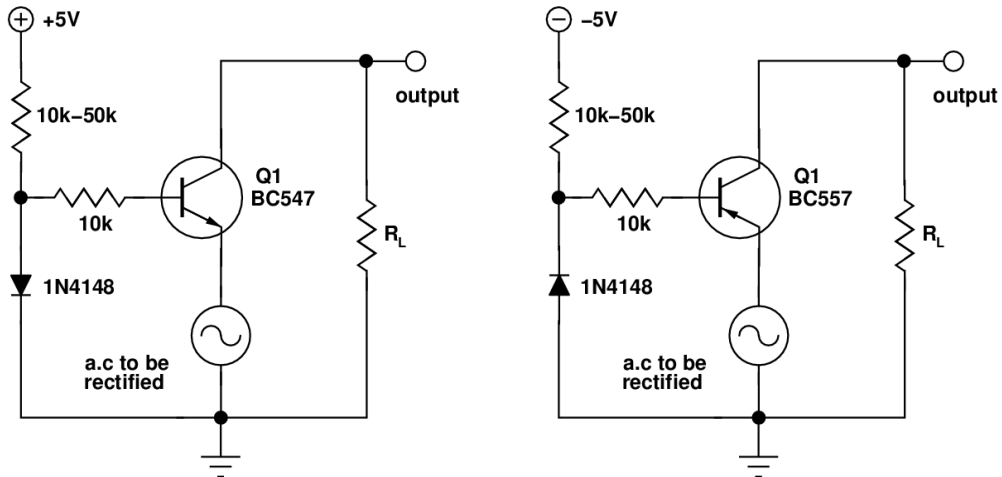

Fig 1: Left : NPN version of transistorized a.c rectifier which passes the -ve half cycles. Right: PNP version of this circuit would pass the +ve half cycles. The rectified d.c would appear across the load resistance R_L . Refer Figure-3,4 for computer simulation results in **Linux Qucs**.

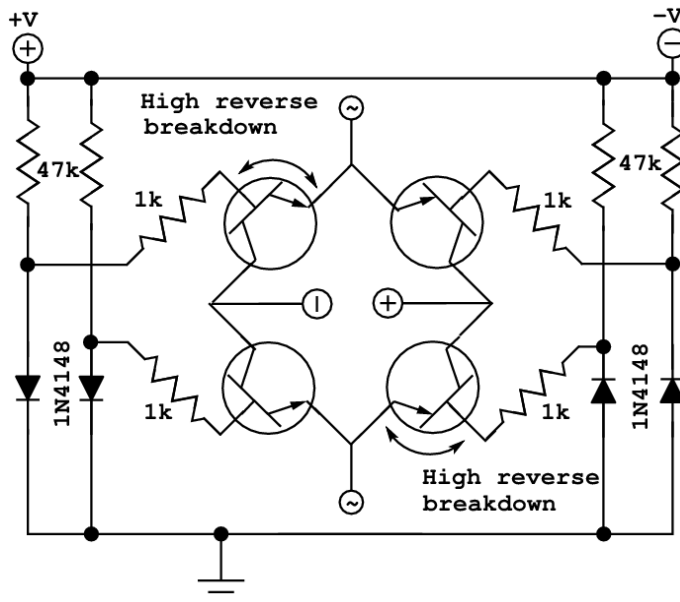

Fig 2: A transistorized bridge rectifier using 2 NPN and 2 PNP transistors replacing the diodes in the standard configuration. The biasing to the transistors is obtained from the voltage drop across the diodes(1N4148) in the side arms. The transistors should have high reverse breakdown voltage for BE junction. The supply voltage($\pm V$) should be less than this reverse breakdown voltage of the transistors.

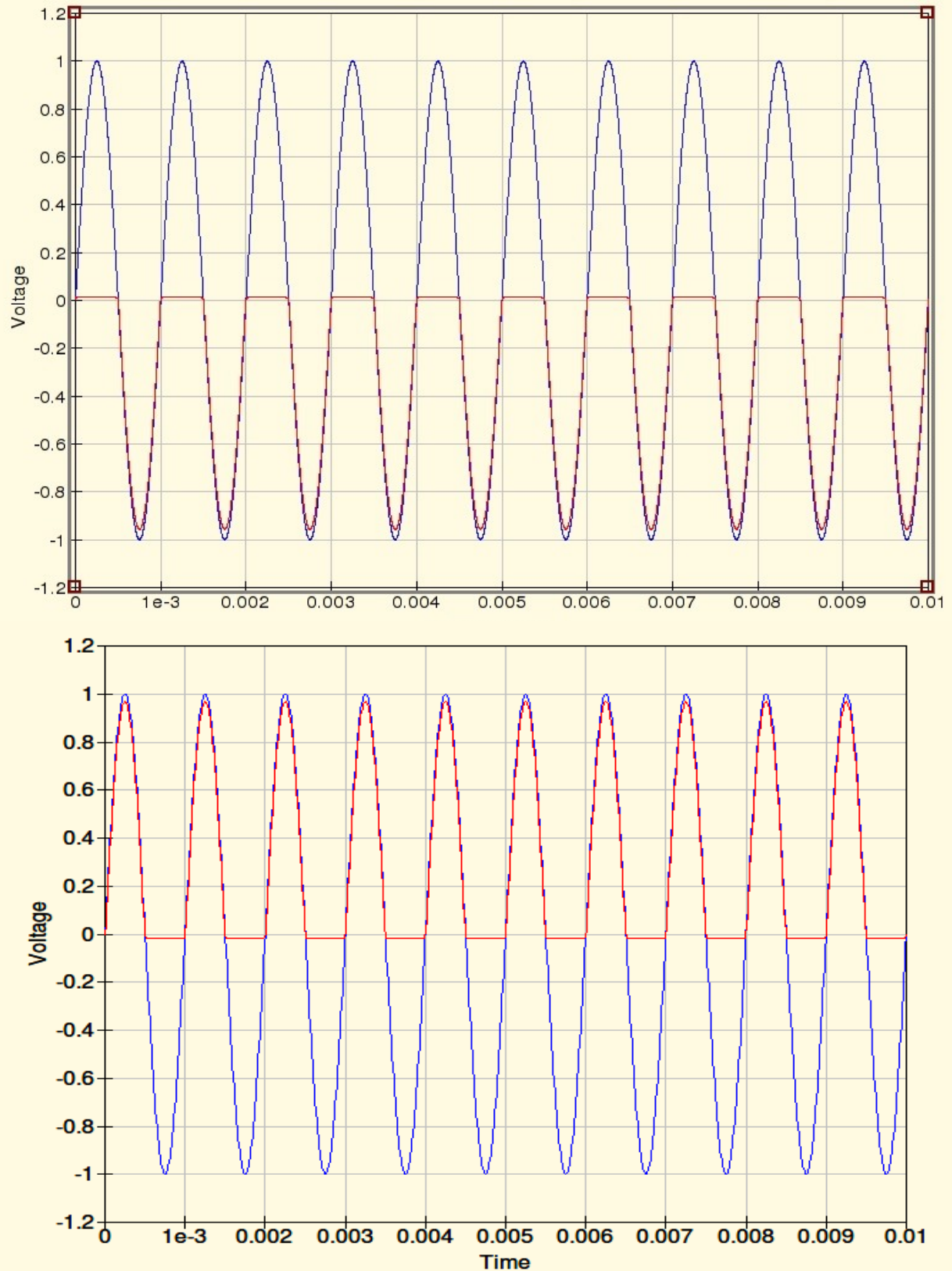

Fig 3: Computer simulation in Linux-Qucs at 1kHz/1V input(blue) the output at the collector is in red. The top panel corresponds to npn version while the bottom panel corresponds to pnp version. $R_L = 1k$, $R_B=10k$, and the series resistor to the diode =50k.

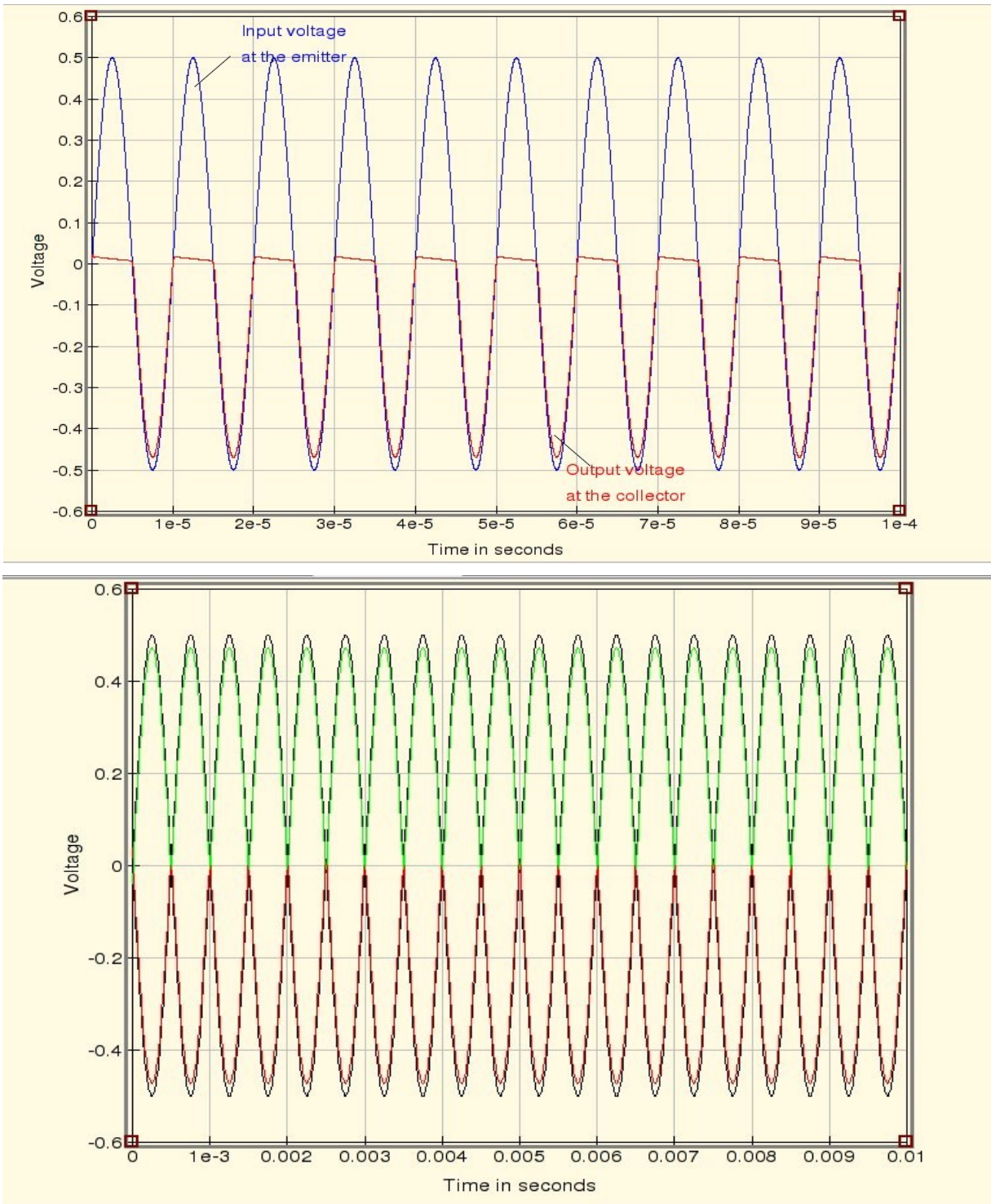

Fig 4: 100kHz 1.0V peak-peak input to the half wave rectifier(top) and full wave rectifier(bottom). Black is the input a.c, Green/Red are from the bridge rectifier.

Appendix discusses some of the quantitative-aspects/applications of the rectifier to justify its usefulness as a low current rectifier.

APPENDIX

The forward bias and reverse bias operation of the NPN transistor rectifier are understood as shown in Figure 5. During forward bias(left figure) the voltage drop across the biasing diode $V_D \sim 0.6V$ supplies the necessary base-emitter voltage drop for Q1. The negative voltage V_{ac} w.r.t ground during this phase sees the LOOP1 and a current $\sim V_{ac}/R_B$ should flow through R_B . This causes a voltage drop of $\sim V_{ac}$ across R_B . It is assumed that V_{ac}/R_B is drawn from the biasing diodes(assuming R_D is sufficiently low, however if R_D is high then current through R_B can be lower) current which can only cause a small change in its voltage drop as per its I-V characteristics. V_{ac} also sets up current V_{ac}/R_L in the load resistor. If V_{ac} is further increased it can even lead to

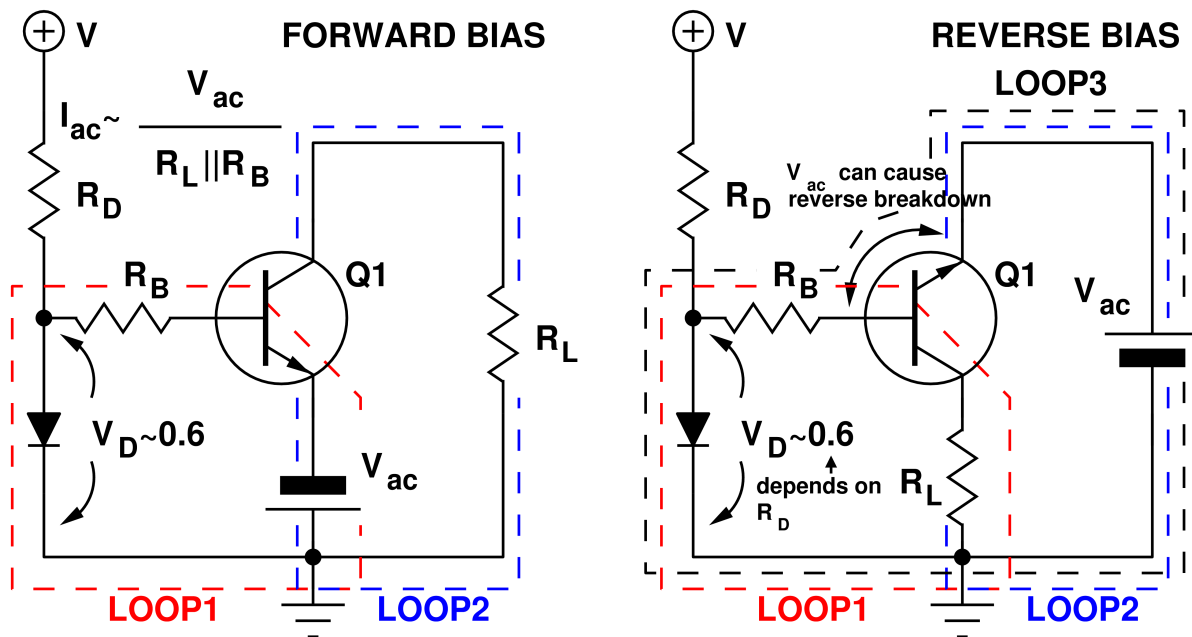
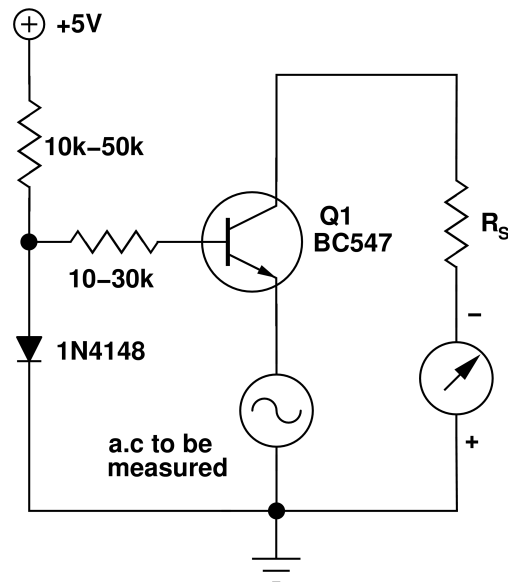

Fig 5 : Forward(left) and Reverse(right) bias configurations of the transistor rectifier. During forward bias V_{ac} sees loops 1 and 2 and current flows in both the resistors. Essentially V_{ac} sees a impedance of $R_B || R_L$ (when R_D is sufficiently low, else impedance is higher). If R_B is considerably higher than R_L then impedance is $\sim R_L$. Under reverse bias the configuration is similar to a voltage follower circuit but with emitter in place of collector and viceversa. As the voltage drop across the biasing diode is just sufficient for the BC junction only a weak constant current flows through R_L which can be seen in Figure 3 as weak leakage during the cutoff phase of ac.

reversing the voltage drop across the biasing diode(impedance : $V_{ac}(R_D+R_B)/(V_{ac}+V) || R_L$). However the upper limit on V_{ac} is set by the reverse break down of BE junction (loop 3)which would be unfavourable for the life of the transistor. Further the value of R_D plays a role in the reverse leakage current which is seen as a small constant voltage during the cutoff phase of ac(Figure 3). Smaller the value of R_D higher is the voltage drop across biasing diode and more will be the leakage. The same is true for R_B as well, however R_B also plays a role in impedance seen by V_{ac} . During reverse bias(Figure 5, right) the configuration is similar to that of a voltage follower however with the emitter replacing the collector and viceversa. Under this condition the voltage drop across the biasing diode is just sufficient to supply the BC junction forward biasing and not much is left for the voltage drop across R_L if a current starts flowing through it. However a weak current can still flow through R_L which depends on the voltage drop across the diode and in turn on the value of R_D . This leakage is seen in Figure 3 as a small constant voltage(\sim few 10mV).

1. SMALL SIGNAL AC VOLTMETER

The half wave rectifier in Fig 1 can be used to build a simple a.c voltmeter(Fig 6) which can measure a.c voltages as low as 0.3V which using conventional 600mV voltage drop silicon diode is not possible, however one can still use a schottky diode(~150mV). The transistor gives a much smaller(5 times) voltage drop across its CE terminals and acts as a diode with ~30mV voltage drop. The schematic circuit diagram of the a.c voltmeter is as shown in Fig 5.



*Fig 6 : Small signal a.c voltmeter. Resistor R_s is chosen such that full scale deflection corresponds to chosen range of the instrument. R_s can be either chosen by trial and error or calculated assuming the transistor to be an ideal rectifier. Illustrations and diagrams created using **Linux: xfig** tool.*

2. INDUCTANCE METER

The half wave rectifier configuration can be used to build a simple LR based inductance meter that would have a linear scale with inductance(*EDN, April 05 2012*). The single transistor half wave rectifier configuration is at the heart of this circuit even though the implementation of the circuit requires numerous other circuit elements which basically control electronic switches.

REFERENCES

Baddi R., *Use a transistor and an ammeter to measure inductance*, *Design Ideas, EDN*, April 05, 2012 .

http://en.wikipedia.org/wiki/Schottky_diode

Kasatkin A.S., Nemtsov M.V., *Electrical Engineering*, Mir Publishers, pp 260(5).

Pookaiyaudom S., Watanachaiprateep C. And Dejhan K., *A Single Transistor Full-Wave Rectifier.*, 1979, Vol 67, Proceedings of the IEEE.