

# A volume-preserving counterexample to the Seifert conjecture

Greg Kuperberg\*

Department of Mathematics, Yale University, New Haven, CT 06637<sup>†</sup>

(Dated: April 29, 1995)

We prove that every 3-manifold possesses a  $C^1$ , volume-preserving flow with no fixed points and no closed trajectories. The main construction is a volume-preserving version of the Schweitzer plug. We also prove that every 3-manifold possesses a volume-preserving,  $C^\infty$  flow with discrete closed trajectories and no fixed points (as well as a PL flow with the same geometry), which is needed for the first result. The proof uses a Dehn-twisted Wilson-type plug which also preserves volume.

MSC classification (1991): Primary 58F25; Secondary 57R30, 28D10, 58F05, 58F22

**Theorem 1.** *Every 3-manifold possesses a  $C^1$  volume-preserving flow with no fixed points and no closed trajectories.*

The author was motivated to consider Theorem 1 by the recent discovery of a real analytic counterexample to the Seifert conjecture [5]; the conjecture states that every flow on  $S^3$  has either a fixed point or a closed trajectory. However, the construction presented here is based on the original  $C^1$  counterexample due to Schweitzer [11] and not the new counterexample.

An important property of a volume-preserving flow in 3 dimensions with no fixed points is that the parallel 1-dimensional foliation is transversely symplectic. In particular, such a flow on a 3-manifold  $M$  can be understood as a Hamiltonian flow coming from a symplectic structure on  $M \times \mathbb{R}$ . In this context, the Weinstein conjecture [14] provides an interesting contrast to Theorem 1. It states that a flow on a closed  $(2n + 1)$ -manifold  $M$  which is not only transversely symplectic but also contact must have a closed trajectory if  $H^1(M, \mathbb{Z}) = 0$ . (A contact form on an  $(2n + 1)$ -manifold is a 1-form  $\omega$  such that  $\omega \wedge (d\omega)^{\wedge n}$  does not vanish; the corresponding contact flow is parallel to the kernel of  $d\omega$ .) In particular, Hofer [4] has recently established the Weinstein conjecture for  $S^3$  and his result applies to the  $C^1$  category. Thus, the flow established by theorem 1 is not contact.

For most manifolds, although not  $S^3$ , Theorem 1 depends on the following result.

**Theorem 2.** *Every 3-manifold possesses a  $C^\infty$  volume-preserving flow with no fixed points and a discrete collection of closed trajectories, as well as a transversely measured 1-dimensional PL foliation with discrete closed leaves.*

Theorem 2 is an extension of the 3-dimensional case of Wilson's theorem [15], which establishes flows with no fixed points and discrete closed trajectories, but without the volume preservation condition. Like Wilson's theorem and all known counterexamples to the Seifert conjecture, Theorems 1 and 2 both use the standard technique of constructing plugs and inserting them into other flows. However, volume preservation

restricts the behavior of a plug, and in particular a volume-preserving plug cannot stop an open set. To work around this serious constraint, Theorem 2 uses twisted plugs, which are plugs whose insertions into manifolds can change the topology of the manifolds. However, the twisted plugs constructed here are only  $C^\infty$  and not real analytic. The generalization of Theorem 2 to the real analytic case remains open.

I am grateful to Krystyna Kuperberg for encouragement and important discussions about the research presented here. I would also like to thank Shmuel Weinberger and Étienne Ghys for their interest in the results and useful comments.

## 1. PRELIMINARIES

In this paper, we will mainly consider three smoothness categories:  $C^r$  for finite  $r$ ,  $C^\infty$  or smooth, and PL. In many contexts, an object will have implicit smoothness; for example, a map between PL manifolds will be assumed to be PL. Unless explicitly stated otherwise, all of the arguments assume that manifolds are oriented and connected but generalize easily to non-orientable and disconnected manifolds.

The paper will use several different  $C^\infty$  bump functions and transition functions. Let  $b : [0, 1] \rightarrow \mathbb{R}$  be a non-negative  $C^\infty$  function with support  $[1/3, 2/3]$  whose integral is 1 and which does not exceed 4. Let  $B : [0, 1] \rightarrow \mathbb{R}$  be a non-negative  $C^\infty$  function whose value and derivatives vanish at 0 and 1 and such that  $B(x) > b(x) \geq 0$  for  $0 < x < 1$ . Let  $e : [-1, 1] \rightarrow \mathbb{R}$  be a non-negative  $C^\infty$  function such that:

$$e(x) \begin{cases} = 0 & |x| \geq 2/3 \\ < 1 & |x| > 1/3 \\ = 1 & |x| \leq 1/3 \end{cases}$$

Finally, let  $o : [-1, 1] \rightarrow \mathbb{R}$  be a  $C^\infty$  odd, increasing function (i.e.,  $o(x) > o(y)$  if  $x > y$  and  $o(-x) = -o(x)$ ) such that  $o(1) = 1$  and all derivatives of  $o$  vanish at the origin.

### 1.1. Foliations and volume-preserving flows

In a standard mathematical treatment of fluid motion, a vector field  $\vec{v}$  in  $\mathbb{R}^n$  represents a static flow, and if the divergence equation

$$\vec{\nabla} \cdot \vec{v} = 0$$

\*Electronic address: greg@math.yale.edu

<sup>†</sup>The author was supported by an NSF Postdoctoral Fellowship, grant #DMS-9107908.

holds, the flow preserves volume. This definition must be carefully generalized to flows on manifolds. A *smooth measure structure* on a smooth  $n$ -manifold is in general given by a smooth, non-vanishing  $n$ -form or *volume form*. It is a simple result that any volume form is equivalent to Lebesgue measure by a local diffeomorphism. More interestingly, Moser's theorem [7] states that a compact manifold  $M$  with two volume forms  $\mu_1$  and  $\mu_2$  with the same total volume admits a diffeomorphism taking  $\mu_1$  to  $\mu_2$ . Given a volume form  $\mu$  on a manifold  $M$ , the divergence equation for a tangent vector field  $\vec{v}$  on a manifold becomes

$$d(\iota_{\vec{v}}(\mu)) = 0,$$

where the operator  $\iota_{\vec{v}}$  is contraction with  $\vec{v}$ . The closed  $(n-1)$ -form  $\iota_{\vec{v}}(\mu)$  is a *flux form*. This formalism is compatible with another view of flows. For  $M$  closed, a flow can be defined as a smooth group action  $\Phi : \mathbb{R} \times M \rightarrow M$ ; the vector field  $\vec{v}$  is related to the group action  $\Phi$  by

$$\vec{v} = \frac{d\Phi}{dt}.$$

It is easy to check that the condition that  $\mu$  is invariant under  $\Phi$  is equivalent to the divergence equation.

Since contraction with  $\mu$  is an invertible linear transformation, given a flux form  $\omega$ , any volume form  $\mu$  yields a vector field  $\vec{v}$  such that

$$\omega = \iota_{\vec{v}}(\mu),$$

with the conclusion that  $\vec{v}$  preserves  $\mu$ . Moreover, the trajectories of  $\vec{v}$ , that is the curves parallel to  $\vec{v}$ , are determined by  $\omega$ , since  $\omega$  has a 1-dimensional kernel at a point of  $M$  where it does not vanish, and it is easy to check that  $\vec{v}$  is a non-vanishing vector in the kernel at that point. Where  $\omega$  does vanish,  $\vec{v}$  vanishes also.

A useful special case of the flux form view is  $n = 2$ , for then a flux form  $\omega$  is the differential of a possibly multiply-valued function  $f$ . Dualizing by some area form, the trajectories of the vector field  $\vec{v}$  obtained from  $\omega = df$  are simply the contours of  $f$ . If the manifold  $M$  has a Riemannian metric and the volume form is given by the metric, then  $\vec{v}$  can also be defined as  $J(\vec{\nabla}f)$ , where  $J$  is a rotation by 90 degrees. This expression is also validated by the standard identity

$$\vec{\nabla} \cdot J(\vec{\nabla}f) = 0$$

from 2-dimensional vector calculus.

If  $\vec{v}$  has no fixed points, its trajectories form a 1-dimensional, oriented foliation  $\mathcal{F}$  of the manifold  $M$ . The usual Seifert conjecture can be phrased as a question about foliations rather than flows: Is there an oriented 1-foliation of  $S^3$  with no closed leaves? In the volume-preserving case, the foliation  $\mathcal{F}$  is determined by the flux form  $\omega$  and otherwise does not depend on  $\vec{v}$  or the volume form;  $\mathcal{F}$  can be defined as the unique foliation parallel to the kernel of  $\omega$ , which is a line bundle over  $M$ . Since  $\omega$  is closed, it determines a (transverse) measure on  $\mathcal{F}$ . A *measure* on a  $k$ -foliation of an  $n$ -manifold is in general defined as a measure for every transverse  $(n-k)$ -disk which is invariant under isotopy of the disk parallel to

the foliation. In this case, given an  $(n-1)$ -disk  $D^{n-1}$  transversely embedded by  $\alpha : D^{n-1} \rightarrow M$ , the measure on  $D^{n-1}$  is given by the pullback  $\alpha^*(\omega)$ , which is a smooth volume form. The measure induced by  $\omega$  can be called smooth and locally Lebesgue just as volume forms are.

As a point of terminology, if  $\mathcal{F}$  is a foliation of  $M$ ,  $M$  is the *support* of  $\mathcal{F}$ . Also, henceforth the term foliation will mean an oriented 1-foliation except where explicitly stated otherwise.

The simplest important construction with foliations is the suspension. (In topology the suspension is called the mapping torus and the term suspension is used for a different construction). Given a manifold  $M$  and a diffeomorphism  $\sigma : M \rightarrow M$ , the *suspension* is the manifold  $M \times \mathbb{R}$  foliated by lines  $p \times I$  and quotiented by the relation  $(p, x) \sim (\sigma(p), x - 1)$ . The main properties of the suspension used in this paper are that  $\mathcal{F}$  is measured if  $\sigma$  preserves volume of  $M$  and that closed leaves of  $\mathcal{F}$  correspond to finite orbits of  $\sigma$ . Note also that if  $\sigma$  is isotopic or even pseudoisotopic to the identity, the support of  $\mathcal{F}$  is diffeomorphic to  $M \times S^1$ .

## 1.2. PL foliations

Recall that a  $k$ -foliation of an  $n$ -manifold is an atlas of charts such that each gluing map preserves horizontal  $k$ -planes in  $\mathbb{R}^n$ . In other words, each gluing map can be written as

$$g(\vec{x}) = (g_1(\vec{x}), g_2(\vec{x}), \dots, g_k(\vec{x}), \\ g_{k+1}(x_{k+1}, \dots, x_n), \dots, g_n(x_{k+1}, \dots, x_n)).$$

A  $k$ -foliation is PL if the gluing maps are PL, smooth if the gluing maps are smooth, and has a (locally Lebesgue) measure if the transverse part  $(g_{k+1}, \dots, g_n)$  of each gluing map preserves Lebesgue measure on  $\mathbb{R}^{n-k}$ . In the smooth case, this definition is equivalent to the one in terms of flux forms. However, in the PL case, the atlas definition seems to be the best substitute for flux forms. Note that suspensions generalize the PL case.

Similarly, a (locally Lebesgue) measure structure on an  $n$ -manifold can be defined as an atlas of charts such that the gluing maps preserve Lebesgue measure on  $\mathbb{R}^n$ ; in the smooth case such an atlas is equivalent to a volume form. In the PL case, such an atlas is an example of a simplicial measure. A measure on a PL manifold is *simplicial* relative to a triangulation  $T$  if on each simplex the measure is given by a linear embedding of the simplex in Euclidean space. The following analogue of Moser's theorem demonstrates that simplicial measures are the PL analogue of volume forms:

**Theorem 3.** *Two simplicial measures on a connected, compact PL  $n$ -manifold  $M$  with the same total volume are equivalent by a PL homeomorphism. Moreover, any simplicial measure is locally PL-Lebesgue.*

*Proof.* Let  $\mu_1$  and  $\mu_2$  be two simplicial measures on  $M$  and let  $\mathcal{T}$  be a triangulation for which both measures are simplicial. For any pair of simplices  $T_1$  and  $T_2$  of  $\mathcal{T}$  that meet at

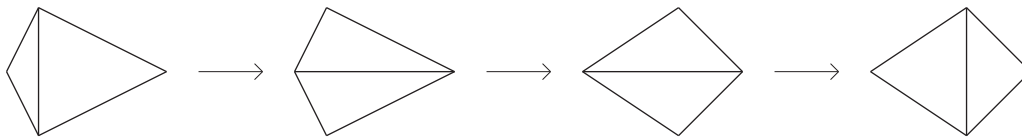

Figure 1: Transfer of measure between adjacent simplices

an  $n - 1$ -dimensional face, there is a family of PL homeomorphisms of  $T_1 \cup T_2$  which take measures which are simplicial on the triangulation  $\{T_1, T_2\}$  to other such measures and which transfer measure from  $T_1$  to  $T_2$ . Figure 1 shows an example of such a homeomorphism: In the figure,  $T_1$  and  $T_2$  are embedded in such a way that their volumes are proportional to their given measure. We retriangulate  $T_1 \cup T_2$  with simplices  $U_1, \dots, U_n$  that share a 1-dimensional edge. There is then a homeomorphism  $\phi$  which is linear and volume-preserving on each simplex  $U_i$  such that image is a union of two simplices  $T'_1$  and  $T'_2$  whose volumes differ from  $T_1$  and  $T_2$ . By identifying  $T'_1$  with  $T_1$  and  $T'_2$  with  $T_2$ ,  $\phi$  can be understood as a PL map that transfers measure from  $T_1$  to  $T_2$ .

Thus, using PL homeomorphisms modelled on  $\phi$ , we can transfer measure arbitrarily between adjacent simplices of  $\mathcal{T}$ , as long as the measure of each simplex remains positive. Such moves clearly suffice to connect any two measures  $\mu_1$  and  $\mu_2$ : By analogy, a connected graph of people, each with a positive amount of money, can arbitrarily redistribute their assets solely by having adjacent individuals transfer money; moreover, the transfers need not drive any individual into debt.

The PL maps so produced fix the vertices of  $\mathcal{T}$ , even though they are not linear on the simplices of  $\mathcal{T}$ . To show the second claim, let  $\mu$  be a measure simplicial relative to  $\mathcal{T}$ , let  $x$  be a point in  $M$ , and let  $y$  be a point in  $M$  in the interior of some simplex of  $\mathcal{T}$ . The measure  $\mu$  is clearly PL-Lebesgue in a neighborhood of  $y$ . Let  $\mu_1 = \mu$ , let  $\mu_2 = \alpha(\mu_1)$ , where  $\alpha$  is a PL homeomorphism of  $M$  that takes  $y$  to  $x$ , and let  $\mathcal{U}$  be a mutual refinement of  $\mathcal{T}$  and  $\alpha(\mathcal{T})$ . The points  $x$  and  $y$  are both vertices of  $\mathcal{U}$  and  $\mu_1$  and  $\mu_2$  are both simplicial relative to  $\mathcal{U}$ . Applying the above argument,  $\mu$  is locally the same at  $x$  and  $y$ , and therefore  $\mu$  is PL-Lebesgue at  $x$  also.  $\square$

### 1.3. The $C^r$ case

A non-vanishing  $C^r$  vector field on a manifold  $M$  yields a  $C^r$  foliation (a foliation with  $C^r$  gluing maps), which yields a  $C^r$  structure for the manifold, but unfortunately the smoothness of vector fields on a  $C^r$  manifold is only defined up to  $C^{r-1}$ . Similarly, a  $C^r$  manifold with volume-preserving gluing maps only has a  $C^{r-1}$  volume form. If both structures are present, the vector field can be smoothed to  $C^r$  [13], but usually at the expense of crumpling a  $C^\infty$  volume form to  $C^{r-1}$ . Alternatively, by a refinement of Moser's theorem [8], a  $C^{r-1}$  plus Hölder volume form can be smoothed to  $C^\infty$ , but only by a  $C^r$  plus Hölder diffeomorphism which might crumple a  $C^r$  vector field so that it is only  $C^{r-1}$  plus Hölder.

In this paper, a volume-preserving  $C^r$  flow means a  $C^r$  vec-

tor field which is divergenceless relative to a smooth volume form on a smooth manifold. It suffices to consider  $C^r$  flux forms on smooth manifolds (or at least  $C^{r+1}$  manifolds). In particular, such a flux form defines a measured  $C^r$  foliation. Although a  $C^r$  flux form is not exactly the same as such a foliation, it is very similar and for some purposes it will be convenient to treat it as one. When we need to glue together flux forms, we will require that they are smooth in the gluing regions, so that in these regions they are equivalent to smooth measured foliations.

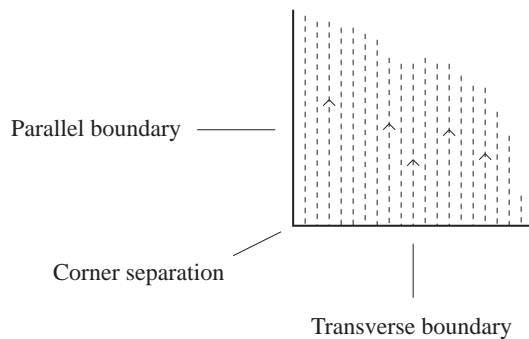

Figure 2: Corner separation

## 2. PLUGS

To define plugs, we must consider a class of manifolds with at least some kinds of corners. The smallest convenient such class is the class of orthant manifolds. An  $n$ -dimensional *orthant manifold* is a Hausdorff space locally homeomorphic to some open subset of the orthant in  $\mathbb{R}^n$  of points with non-negative coordinates. In the PL category, an orthant manifold is just a manifold with boundary, but in the smooth category, the boundary might not be smooth. For example, a parallelepiped is a smooth orthant manifold.

A foliation can have many different kinds of structure at the boundary of an orthant manifold, not to mention the boundary of an ordinary manifold with boundary, but to define a plug three kinds of boundary structure suffice: *parallel boundary*, *transverse boundary*, and *corner separation* between parallel and transverse boundary. Figure 2 shows an example of each type of boundary. Recall some definitions from reference [6]: A *flow bordism* is a foliation  $\mathcal{P}$  on a compact orthant manifold  $P$  such that  $\partial P$  is entirely transverse boundary, parallel boundary, or corner separation, and such that all leaves in

the parallel boundary of  $P$  are finite. If  $\mathcal{P}$  is a flow bordism, let  $F_-$  be the (closure of) all transverse boundary oriented inward, and similarly let  $F_+$  be the transverse boundary oriented outward. The foliation  $\mathcal{P}$  might in addition have one or both of the following properties:

- (i) There exists an infinite leaf with an endpoint in  $F_-$ .
- (ii) There exists a manifold  $F$  and homeomorphisms  $\alpha_{\pm} : F \rightarrow F_{\pm}$  such that if  $\alpha_+(p)$  and  $\alpha_-(q)$  are endpoints of a leaf of  $\mathcal{P}$ , then  $p = q$ .

If  $\mathcal{P}$  satisfies property (ii), it has *matched ends*. The foliation  $\mathcal{P}$  is a *plug* if it has properties (i) and (ii), but only a *semi-plug* if it has property (i) but not property (ii). It is an *un-plug* if has property (ii) but not property (i). The manifold  $F_-$  is the *entry region* of  $\mathcal{P}$ , while  $F_+$  is the *exit region*. If  $\mathcal{P}$  has matched ends, then  $F$  is the base of  $\mathcal{P}$ . The *entry stopped set*  $S_-$  of  $\mathcal{P}$  is the set of points of  $F_-$  which are endpoints of infinite leaves; the *exit stopped set*  $S_+$  is defined similarly. If  $\mathcal{P}$  has matched ends, the stopped set  $S$  is defined as  $\alpha_-^{-1}(S_-) = \alpha_+^{-1}(S_+)$ . If  $\mathcal{P}$  has matched ends and  $S$  contains an open set, then  $\mathcal{P}$  *stops content*, i.e., has wandering points in  $F$ .

An important construction due to Wilson [15] turns a semi-plug into a plug. If  $\mathcal{P}_1$  and  $\mathcal{P}_2$  are two flow bordisms such that the exit region of  $\mathcal{P}_1$  is the same as the entry region of  $\mathcal{P}_2$ , their *concatenation* is a flow bordism obtained by identifying trivially foliated neighborhoods of this shared region. The *mirror image*  $\bar{\mathcal{P}}$  of a flow bordism  $\mathcal{P}$  is given by reversing the orientation of the leaves of  $\mathcal{P}$ , which has the effect of switching the entry and exit regions. The *mirror-image construction* is the concatenation of  $\mathcal{P}$  and  $\bar{\mathcal{P}}$ ; it is easy to see that the result of this concatenation has matched ends.

The primary purpose of plugs is the operation of insertion. An *insertion map* for a plug  $\mathcal{P}$  into a foliation  $\mathcal{X}$  is an embedding  $F \rightarrow X$  of the base of  $\mathcal{P}$  which is transverse to  $\mathcal{X}$ . Such an insertion map can be extended to an embedding  $\sigma : F \times I \rightarrow X$  which takes the fiber foliation of  $F \times I$  to  $\mathcal{X}$ . An  $n$ -dimensional plug  $\mathcal{P}$  is insertible if  $F$  admits an embedding in  $\mathbb{R}^n$  which is transverse to vertical lines. Such an embedding is equivalent to a bridge immersion of  $F$  in  $\mathbb{R}^{n-1}$ , i.e., an immersion which lifts to an embedding one dimension higher. Figure 3 shows a bridge immersion of a punctured torus  $pT$ ; the corresponding embedding of  $F \times I$  is the one that Schweitzer also uses.

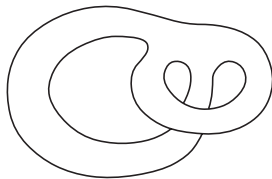

Figure 3: A bridge immersion

Let  $N_{F \times I}$  be an open neighborhood of  $\partial(F \times I)$ . The next step in plug insertion is to remove  $\sigma((F \times I) - N_{F \times I})$  from  $X$  and glue the open lip  $\sigma(N_{F \times I})$  to  $P$  by a leaf-preserving

homeomorphism  $\alpha : N_{F \times I} \rightarrow N_P$ , where  $N_P$  is a neighborhood of  $\partial P$ . Moreover, the identification  $\alpha$  should satisfy  $\alpha(p, 0) = \alpha_-(p)$  and  $\alpha(p, 1) = \alpha_+(p)$ . A map  $\alpha$  with these properties is an *attaching map* for  $\mathcal{P}$ . As explained in Reference [6], plugs always possess attaching maps.

Let  $\sigma$  be an insertion map of a plug  $\mathcal{P}$  into a foliation  $\mathcal{X}$  on a manifold  $X$ , and let  $\hat{\mathcal{X}}$  be the foliation on the manifold  $\hat{X}$  resulting from the insertion of  $\mathcal{P}$  into  $\mathcal{X}$ . The plug  $\mathcal{P}$  is *untwisted* if the attaching map  $\alpha$  extends to a homeomorphism  $F \times I \rightarrow P$ , and *twisted* otherwise. If  $\mathcal{P}$  is untwisted, then  $X$  and  $\hat{X}$  are necessarily homeomorphic, while if  $\mathcal{P}$  is twisted, then  $X$  and  $\hat{X}$  need not be homeomorphic. This paper will use both twisted and untwisted plugs.

A useful lemma about plugs proved in Reference [6] is the following:

**Lemma 4.** *A flow bordism with an infinite leaf with non-empty entry or exit region is either a plug or a semi-plug.*

## 2.1. Measured and $C^r$ plugs

The technique of plugs generalizes without any substantive changes to the category of measured foliations, either smooth or PL. The base  $F$  of a measured plug is measured, but by Moser's theorem, the only relevance of this structure is that a bridge immersion of  $F$  with large volume into a disk with small volume is inconvenient, although not strictly impossible, if  $F$  has large volume. One way to overcome this inconvenience is to rescale the transverse measure of the plug to make the measure of  $F$  small. Note also that a measured plug cannot stop content.

The category of measured,  $C^r$  foliations is trickier. Following the prescription of subsection 1.3, a measured  $C^r$  flow bordism is realized by a  $C^r$  flux form on a smooth manifold. A flow bordism with support  $P$  is *attachable* if the flux form is smooth in a neighborhood  $N_P$  of the boundary, so that the foliation method can be used to insert it without loss of smoothness.

A  $n$ -dimensional, measured  $C^r$  semi-plug  $\mathcal{P}$  with support  $P$  can always be made attachable by the following method: Since the flux form  $\omega$  is defined over all of  $P$  and  $P$  bounds  $\partial P$ , it is the differential of an  $(n-2)$ -form  $\nu$  in a neighborhood of the boundary  $N_P$ . Let  $\nu'$  be an  $(n-2)$ -form which is a smooth approximation to  $\nu$  in a smaller neighborhood of  $\partial P$ , agrees with  $\nu$  in a neighborhood of  $P - N_P$ , and is an interpolation with a smooth bump function in between. In addition, choose  $\nu'$  so that  $d\nu'$  has the same parallel and transverse boundary at  $\partial P$  as does  $\omega$ . Then the flux form which is  $d\nu'$  on  $N_P$  and  $\omega$  on  $P - N_P$  yields an attachable semi-plug  $\mathcal{P}'$  with the same leaf structure as  $\mathcal{P}$ . Furthermore, the mirror-image construction applied to  $\mathcal{P}'$  yields an attachable plug.

## 3. ISOLATED CLOSED TRAJECTORIES

The main construction of the proof of Theorem 2 is a measured, Dehn-twisted plug. Before constructing or even defin-

ing such a plug, we recall several facts about Dehn twists and Dehn surgery: The boundary of a solid torus  $S^1 \times D^2$  has a distinguished embedded circle, the *meridian*, which is unique up to isotopy and which is identified by the fact that it bounds a disk in the solid torus. A *framing* of a solid torus is a homotopy class of another circle in the boundary; the framing may or may not equal the meridian. A framing is *integral* if it homologically crosses the meridian exactly once. A *Dehn surgery* on a 3-manifold consists of removing a collection of disjoint framed tori and gluing them back in such a way that the new meridian circles match the old framing circles; the topology of the resulting manifold does not otherwise depend on the gluing maps. The Lickorish-Wallace theorem [10] asserts that every closed, oriented 3-manifold can be obtained from  $S^3$  by integral Dehn surgery, or equivalently every closed, oriented 3-manifold can be obtained from every other by integral Dehn surgery. In the second formulation, the theorem also holds for non-orientable manifolds.

Suppose that  $\mathcal{D}$  is a plug with base  $F = S^1 \times I$  whose support  $P$  is homeomorphic to a solid torus  $S^1 \times D^2$ . Recall that there is an attaching map  $\alpha : N_{F \times I} \rightarrow N_P$  between neighborhoods of the boundary, and note that the thickened base  $F \times I$  is also a solid torus. If  $p \in S^1$ , the curve  $m = \{p\} \times \partial(I \times I)$  is a meridian of  $F \times I$ , while the curve  $l = S^1 \times \{0\} \times \{0\}$  is a convenient standard framing which might be called the *longitude*. Recall that when  $\mathcal{D}$  is inserted, its support  $P$  replaces an image of  $F \times I$  by the attaching map  $\alpha$ . Therefore if  $\alpha(m)$  is a meridian of  $P$ , meridian replaces meridian,  $\alpha$  extends to a homeomorphism  $\alpha : F \times I \rightarrow P$ , and  $\mathcal{D}$  is untwisted. If, alternatively, the meridian of  $P$  replaces some other curve of  $F \times I$ ,  $\mathcal{D}$  can be called Dehn-twisted, because its insertion effects a Dehn surgery. In particular, if either  $\alpha(m+l)$  or  $\alpha(m-l)$  (using homological notation for other curves besides  $m$  and  $l$ ) is a meridian of  $P$ ,  $\mathcal{D}$  is integrally Dehn-twisted.

An integrally Dehn-twisted plug  $\mathcal{D}$ , assuming that it exists, can be used to construct a foliation on any closed, oriented 3-manifold with finitely many closed leaves as follows: The 3-torus  $T^3$  possesses a smooth, measured foliation  $\mathcal{T}$  such that all leaves are dense: If  $T^3$  is given with periodic coordinates  $\theta_1, \theta_2, \theta_3$ , define  $\mathcal{T}$  to be parallel to the vector field

$$r_1 \frac{\partial}{\partial \theta_1} + r_2 \frac{\partial}{\partial \theta_2} + r_3 \frac{\partial}{\partial \theta_3},$$

where  $r_1, r_2$ , and  $r_3$  are linearly independent over the rationals. Let  $M$  be some other 3-manifold, and let  $L$  be a link in  $T^3$  such that some integral surgery on  $L$  yields  $M$ . If the link  $L$  is transverse to  $\mathcal{T}$ , which can always be achieved by isotopy, then  $L$  can be extended to an insertion map for several copies of  $\mathcal{D}$ . The longitudes of the thickened bases  $F \times I$  along  $L$  are determined by  $\mathcal{T}$ ; they can be chosen to be any desired integral framing by adding coils to  $L$ , as shown in Figure 4. The framing for the surgery induced by inserting  $\mathcal{D}$  is then given by the formula  $m \pm l$  above, and this is also an arbitrary integral framing on each component of  $L$ .

Non-orientable manifolds can similarly be handled as follows: A rotation of a round 2-sphere  $S^2$  by an irrational angle descends to a volume-preserving, smooth diffeomorphism of

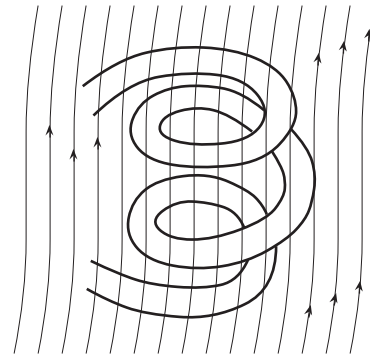

Figure 4: Coiling a Dehn-twisted insertion

the projective plane  $RP^2$  with only one periodic point, a fixed point. The suspension of this diffeomorphism is therefore a measured foliation of  $RP^2 \times S^1$  with one closed leaf. Every other non-orientable, closed 3-manifold can be obtained from this one by appropriate insertions of  $\mathcal{D}$ . An alternative approach is to use the wormhole plug defined in subsection 3.2 to add a non-orientable handle to a foliated, orientable 3-manifold.

In conclusion, the smooth, compact case of Theorem 2 follows from the following lemma:

**Lemma 5.** *There exists a smooth, measured, integrally Dehn-twisted plug  $\mathcal{D}$  with two closed leaves.*

*Proof.* As a warm-up, we construct an untwisted, measured plug with two closed leaves. Let  $F = \{(r, \theta) | 1 \leq r \leq 3\}$  be an annulus in the plane given in polar coordinates, but with the volume form  $dr \wedge d\theta$  rather than the form given by the embedding in the plane. Consider  $C = F \times [-1, 1]$  in cylindrical coordinates  $r, \theta$ , and  $z$ . Let  $f : [1, 3] \times [-1, 1] \rightarrow \mathbb{R}$  be given by

$$f(r, z) = z^2(r-2) + (1-z^2)(r-2)^3.$$

The contours of  $f$  are given in Figure 5. The function  $f$  has one critical point at  $(2, 0)$ , and all contours of  $f$  connect the top and the bottom, although the  $r = 2$  contour is singular. Let  $\vec{W}$  be a vector field on  $C$  given by

$$\vec{W}_s = J(\vec{\nabla} f) + \frac{\partial}{\partial \theta}.$$

Let  $\mathcal{W}_s$  be the foliation of  $C$  which is parallel to  $\vec{W}$ . The vector field  $\vec{W}_s$  is divergenceless because both terms are divergenceless, and therefore  $\mathcal{W}_s$  is measured. By the geometry of  $f$ , the leaves of  $\mathcal{W}_s$  at  $r \neq 2$  connect the top and the bottom of  $C$ , but the leaves at  $r = 2$  spiral to a closed leaf with  $r = 2$  and  $z = 0$ . It is easy to check that  $(\partial F) \times I$  is parallel boundary of  $\mathcal{W}_s$ , while  $F \times \partial I$  is transverse boundary. In conclusion,  $\mathcal{W}_s$  is a semi-plug with one closed leaf. The mirror-image construction described in section 1 applied to  $\mathcal{W}_s$  yields a plug  $\mathcal{W}$  with two closed leaves.

The plug  $\mathcal{W}$  is necessarily untwisted, because in the notation preceding the lemma, the circle  $\alpha(c)$  consists of two arcs

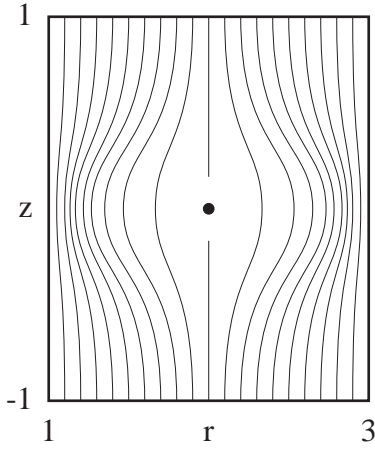
Figure 5: Contours of  $f$ 

with constant  $\theta$ , one in the entry region and the other in the exit region, connected by two leaves of  $\mathcal{W}$ . (See Figure 6a.) By the mirror-image construction, if either leaf winds by some angle  $\theta$  in  $\mathcal{W}_s$ , it unwinds by the same angle in the mirror image  $\tilde{\mathcal{W}}_s$ , so the two leaves together with the two connecting arcs do not wind around the hole of the support of  $\mathcal{W}$  and  $\alpha(c)$  is a meridian.

The main construction is a variant  $\mathcal{P}$  which is a concatenation of a semi-plug  $\mathcal{P}_1$  and the mirror image of another semi-plug  $\mathcal{P}_2$  which is a modification of  $\mathcal{P}_1$ . Both semi-plugs are supported on the space  $C$  defined above. The semi-plug  $\mathcal{P}_2$  is parallel to the vector field

$$\vec{P}_2 = J(\vec{\nabla}g) + \frac{\partial}{\partial\theta},$$

where  $g : [1, 3] \times [-1, 1] \rightarrow \mathbb{R}$  is given by

$$g(r, z) = e(z)o(r-2) + (1-e(z))(r-2).$$

The function  $g$  has zero first derivative on the line segment  $\{2\} \times [-1/3, 1/3]$ , and therefore the foliation  $\mathcal{P}_2$  has an annulus of closed leaves  $\{2\} \times S^1 \times [-1/3, 1/3]$ . The semi-plug  $\mathcal{P}_1$  is parallel to the vector field

$$\vec{P}_1 = J(\vec{\nabla}g) + (3\pi b(\frac{1+3z}{2})o'(r-2) + 1)\frac{\partial}{\partial\theta}$$

when  $z \in [-1/3, 1/3]$  and  $r > 2$ , and equals  $\vec{P}_2$  otherwise. The coefficient of  $\frac{\partial}{\partial\theta}$ , although complicated, does not involve  $\theta$ , so  $\vec{P}_1$  is still a sum of two divergenceless terms. On the other hand, a calculation shows that, for an arc of a trajectory of  $\vec{P}_1$  with  $r > 2$  and  $z \in [-1/3, 1/3]$ ,  $\frac{d\theta}{dz}$  is  $3\pi b(\frac{1+3z}{2})$  greater than it is for a similar arc in  $\vec{P}_2$ , and the integral over  $z$  of this difference is  $2\pi$ . In other words, a leaf of  $\mathcal{P}_1$  with  $r > 2$  has the same endpoints as some leaf of  $\mathcal{P}_2$ , but winds in the  $\theta$  direction by an extra  $2\pi$  exactly. If we concatenate the mirror image of  $\mathcal{P}_2$  to  $\mathcal{P}_1$  in the manner of the mirror-image construction, the result is that leaves with  $r > 2$  wind an angle of  $2\pi$  while leaves with  $r < 2$  wind an angle of 0. Therefore

for the plug  $\mathcal{P}$ , the two sides of the circle  $\alpha(c)$  do not wind around the same amount, and  $\alpha(c)$  is not a meridian for  $\mathcal{P}$ , as shown in Figure 6b. In fact,  $\mathcal{P}$  is integrally Dehn-twisted.

The plug  $\mathcal{P}$  has two annuli of closed leaves. Since the stopped set of  $\mathcal{W}$  is a circle,  $\mathcal{W}$  can be inserted in such a way that all of these closed leaves are broken. The insertion of  $\mathcal{W}$  into  $\mathcal{P}$  produces the desired plug  $\mathcal{D}$  with two closed leaves, as desired.  $\square$

To achieve a measured foliation with very few closed leaves, namely two, on an arbitrary compact 3-manifold  $M$ , we can insert a single copy of  $\mathcal{W}$  that breaks all closed leaves of the foliation of Theorem 2. As an alternative to the proof of Lemma 5, we could equally well insert copies of the plug  $\mathcal{P}$  to effect Dehn surgery on  $T^3$  or  $\mathbb{R}P^2 \times S^1$  and then use one copy of  $\mathcal{W}$  in the final step.

### 3.1. The PL case

The foliation  $\mathcal{T}$  on  $T^3$  is also a measured PL foliation. An irrational rotation of  $\mathbb{R}P^2$  can also be realized as an area-preserving PL homeomorphism. Therefore the following lemma establishes Theorem 2 by the same reasoning as in the smooth case:

**Lemma 6.** *There exists a PL, measured, integrally Dehn-twisted plug  $\mathcal{D}$  with two closed leaves.*

*Proof.* Let  $R$  be a compact, PL submanifold of the plane, given in coordinates  $x$  and  $y$ . Let  $f : R \rightarrow R$  be a PL homeomorphism, and let  $l$  be a real number. Let  $\mathcal{L}$  be the foliation of  $R \times I$  such that, for fixed  $(x, y) \in R$  and  $z \in \mathbb{R}$ , the set  $\{(x, y + lx, z) | (x, y + lz) \in R, z \in I\}$  is a leaf. Orient the leaves in the direction of increasing  $z$ . The *slanted suspension* of  $f$  with slope  $l$  is defined as the space  $R \times I$  with  $(x, y, 1)$  identified to  $(f(x, y), 1)$ , together with the foliation  $\mathcal{S}$  induced by  $\mathcal{L}$ . The slanted suspension  $\mathcal{S}$  is manifestly a PL foliation also. Moreover, if  $f$  preserves area, then  $\mathcal{S}$  is measured.

Let  $T$  be the trapezoid in the plane with vertices  $a_1 = (0, 0)$ ,  $a_2 = (0, 2)$ ,  $a_4 = (1, 1)$ , and  $a_5 = (1, 0)$ , and let  $a_3 = (\frac{1}{3}, 0)$ , as shown in Figure 7. Let  $U$  be the reflection of  $T$  about the line  $x = \frac{1}{2}$ , and let  $b_i$  be the image of  $a_i$  under this reflection. Let  $f : T \rightarrow U$  be the unique PL map which sends  $a_i$  to  $b_{6-i}$  and is linear on each of the three triangles which share the vertex  $a_3$ . Evidently  $f$  is an area-preserving PL homeomorphism. Moreover,  $f$  decreases the  $y$  coordinate of  $a_2$  the most and increases the  $y$  coordinate of  $a_4$  the most.

Let  $R_1 = [-1, 1] \times [0, 3]$  be a rectangle consisting of four congruent copies of  $T$  as shown in Figure 8. We can conjugate  $f$  with three isometries of the plane to extend  $f$  to an area-preserving PL homeomorphism  $g_1 : R_1 \rightarrow R_1$  as also indicated in Figure 8. It is easy to check that the slanted suspension  $\mathcal{S}_1$  of  $g_1$  with slope 1 is a PL analogue of the semi-plug  $\mathcal{W}_s$ ; it is a semi-plug that stops a circle and has one closed leaf.

Let  $R_2$  be the rectangle  $R_1$  union a triangle with vertices  $(0, 3)$ ,  $(1, 3)$ , and  $(1, 5)$ . Let  $g_2 : R_2 \rightarrow R_2$  be a map

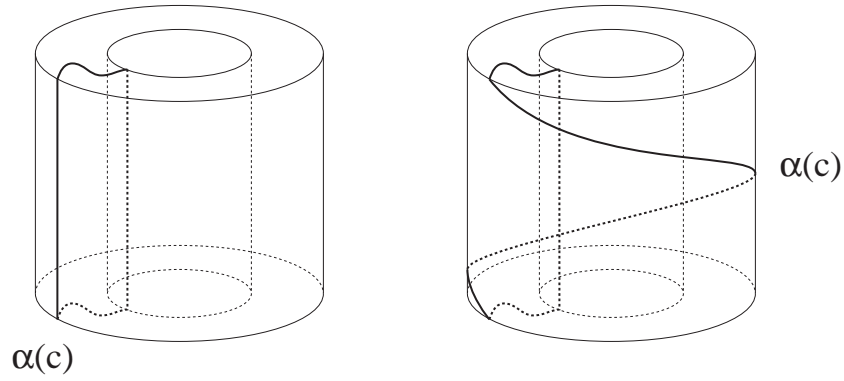
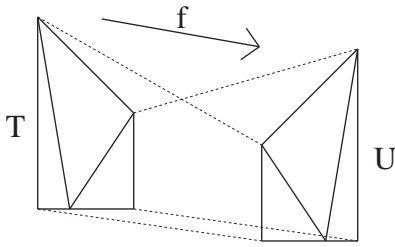
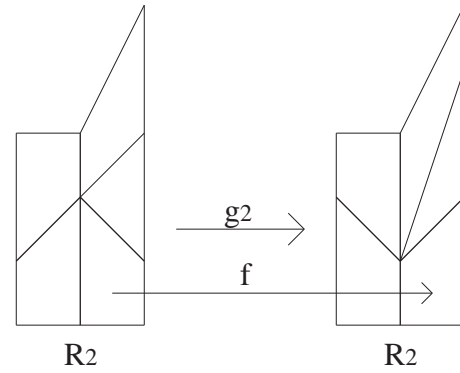
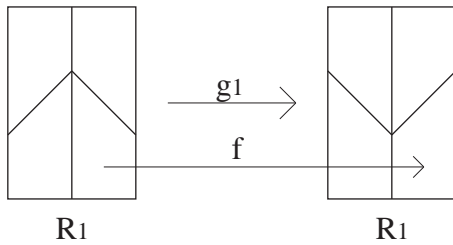
Figure 6: The curves  $\alpha(c)$  in  $\mathcal{W}$  and  $\mathcal{P}$ Figure 7: The map  $f : T \rightarrow U$ Figure 9: The map  $g_2$ Figure 8: The map  $g_1$ 

pieced together from four copies of  $f$ :  $f$  itself, its reflection (in the sense of conjugation) about the  $y$  axis, the rotation by 180 degrees of that reflection about the point  $(-\frac{1}{2}, \frac{3}{2})$ , and the image of  $f$  under the affine transformation  $(x, y) \mapsto (1-x, 5-2x-y)$ . The four copies of  $f$  determine  $g_2$  everywhere except in the triangle with vertices  $(0, 2)$ ,  $(3, 1)$ , and  $(3, 3)$ ;  $g_2$  is defined by  $g_2(x, y) = (x, y+x)$  on this triangle. Figure 9 gives a diagram of the map  $g_2$ . Let  $\mathcal{P}_2$  be the slanted suspension of  $\alpha_2$  with slope 1. It is easy to check that  $\mathcal{P}_2$  is a semi-plug with one closed leaf as well.

The goal is to concatenate  $\mathcal{S}_1$  and  $\mathcal{S}_2$  to produce a plug  $\mathcal{S}_{PL}$ , but we must be careful to properly match the entry and exit regions. Let  $F_{1,\pm}$  and  $F_{2,\pm}$  be the entry and exit regions of  $\mathcal{S}_1$  and  $\mathcal{S}_2$ ; all four are subsets of  $\mathbb{R}^2 \times [0, 1]$  with  $\mathbb{R}^2 \times \{0\}$  and  $\mathbb{R}^2 \times \{1\}$  identified. Let  $F = F_{1,-} = F_{2,-}$ , and let  $\pi_1 : F_{1,+} \rightarrow F$  and  $\pi_2 : F_{2,+} \rightarrow F$  be vertical projections. Note

that  $\pi_1$  and  $\pi_2$  preserve transverse measure and that transverse measure agrees on  $F_{1,-}$  and  $F_{2,-}$ . The essential property of  $\mathcal{S}_1$  and  $\mathcal{S}_2$  is that if  $p$  and  $\pi_1^{-1}(q)$  are endpoints of a leaf of  $\mathcal{S}_1$ , then  $p$  and  $\pi_2^{-1}(q)$  are the endpoints of another leaf of  $\mathcal{S}_2$  that winds around the suspension direction one extra time. Therefore if  $\mathcal{S}_1$  and  $\bar{\mathcal{S}}_2$  are concatenated with the map  $\pi_2 \circ \pi_1^{-1}$  as a gluing map, the result is an integrally Dehn-twisted plug  $\mathcal{S}$  whose geometry is very similar to that of the plug  $\mathcal{P}$  constructed in the previous subsection. The plug  $\mathcal{S}$  has two closed leaves as desired.  $\square$

### 3.2. Non-compact 3-manifolds

The only extra difficulty in establishing Theorem 2 in the non-compact case is that the Lickorish-Wallace theorem does not generalize. It is not true, for example, that every open 3-manifold is obtained from  $\mathbb{R}^3$  by Dehn surgery on a locally finite link, because any such surgery produces a manifold with only one end. (Recall that the set of ends of a manifold is the inverse limit of the connected components of complements of compact subsets.) On the other hand, the theorem does have the following useful generalization

**Theorem 7.** (*Generalized Lickorish-Wallace theorem*) Given two 3-manifolds  $A$  and  $B$  with a homeomorphism  $\alpha : \partial A \rightarrow \partial B$  there exists a 3-manifold  $\hat{A}$  obtained from  $A$  by integral Dehn surgery on a link disjoint from  $\partial A$  such that  $\alpha$  extends to a homeomorphism  $\alpha : \hat{A} \rightarrow B$ .

*Proof.* (Sketch) For closed manifolds, the Lickorish-Wallace theorem essentially says that any 3-manifold bounds a 4-manifold, since an integral Dehn surgery is a Morse reconstruction at a critical point of index 2, for 3-manifolds viewed as level surfaces of Morse functions on 4-manifolds. Contrariwise, if two 3-manifolds are level surfaces of the same Morse function, the Morse stratification produces a Dehn surgery connecting them, since any possible Morse reconstruction can be reproduced with Dehn surgery. In the case at hand,  $C = A \cup B \cup (\partial A \times I)$  is a closed 3-manifold if  $\partial A \times \{0\}$  is identified with  $\partial A$  and  $\partial A \times \{1\}$  is identified with  $\partial B$  using  $\alpha$ . The manifold  $C$  bounds a 4-manifold  $W$ ; in fact,  $W$  is naturally an orthant manifold if  $\partial A \times I$  is positioned to meet  $A$  and  $B$  orthogonally. Choosing a Morse function that is 0 on  $A$ , 1 on  $B$ , and  $x$  on  $\partial A \times \{x\}$ , we obtain a sequence of Morse moves that connect  $A$  to  $B$ , which can again be converted to Dehn surgeries.  $\square$

**Lemma 8.** Every non-compact, orientable 3-manifold  $M$  can be realized by a Dehn surgery on a locally finite link in an infinite collection of spheres with connecting handles.

*Proof.* Let  $M$  be a non-compact 3-manifold. Consider a locally finite collection of embedded surfaces in  $M$  which separate  $M$  into compact 3-manifolds  $M_1, M_2, \dots$  with boundary. Let  $S_1, S_2, \dots$  be a collection of 3-spheres, and connect  $S_i$  to  $S_j$  by a handle (in the sense of connected sums) for each connected component of  $M_i \cap M_j$ . The resulting manifold  $P$  is tiled by punctured 3-spheres  $P_1, P_2, \dots$  with the property that  $P_i \cap P_j$  consists of  $n$  2-spheres if  $M_i \cap M_j$  has  $n$  connected components. By attaching handles to these 2-spheres, we can obtain a new tiling  $P'_1, P'_2, \dots$  such that  $P'_i \cap P'_j$  is homeomorphic to  $M_i \cap M_j$ . Applying Theorem 7 to  $P$ , there exists a finite surgery in each  $P'_i$  that yields  $M_i$ . The union of all such surgeries is a locally finite surgery on  $P$  that yields  $M$ .  $\square$

Given Lemma 8, Theorem 2 is established with the aid of a volume-preserving, twisted plug  $\mathcal{H}$  with base  $D^2 \amalg D^2$  and with support  $(D^2 \times I) \# (D^2 \times I)$ . In particular, the base of  $\mathcal{H}$  is not connected, but the support is;  $\mathcal{H}$  is therefore a *wormhole plug*. The insertion of  $\mathcal{H}$  into a foliation of a disconnected manifold effects a connected sum between two different components of the manifold.

**Lemma 9.** There exists a smooth, measured plug  $\mathcal{H}$  with base  $D^2 \amalg D^2$  and support  $(D^2 \times I) \# (D^2 \times I)$ .

*Proof.* The first step in constructing  $\mathcal{H}$  is to construct a semi-plug  $\mathcal{H}_s$  with the same support. Figure 10 shows a flow which is a 2-dimensional analogue of the desired semi-plug: It is a flow in an orthant manifold which is homeomorphic to an annulus. The outside boundary is a square, the inside boundary

is an inverted square, and both the annulus and its flow might be invariant under inversion in a circle in the center of the annulus. Excepting the two fixed points, it is otherwise a flow bordism. Roughly speaking, the 3-dimensional semi-plug  $\mathcal{H}_s$  is parallel to a flow obtained by revolving the 2-dimensional analogue about the vertical axis and adding motion in the angular direction to turn the fixed points into a closed trajectory.

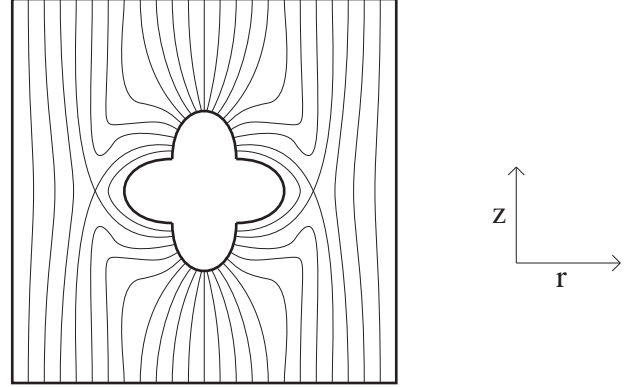

Figure 10: A 2-dimensional wormhole

Explicitly, parameterize  $\mathbb{R}^3$  by Cartesian coordinates  $x, y$ , and  $z$ , and let  $C$  be the cylinder given by  $x^2 + y^2, z^2 \leq 16$ . Let  $\omega = dx \wedge dy$  be a flux form on  $C$ ; the parallel foliation is simply parallel vertical line segments. Let  $\alpha : \mathbb{R}^3 \rightarrow \mathbb{R}^3$  be given by

$$\alpha(x, y, z) = 1 + \frac{1}{x^2 + y^2 + z^2}(x, y, z).$$

Define  $\mathcal{H}_s$  to be the foliation parallel to the flux form

$$\alpha^*(\omega) + x dx \wedge dz + y dy \wedge dz$$

on the domain  $\alpha^{-1}(C)$ . The foliation  $\mathcal{H}_s$  has all of the claimed properties.

The mirror-image construction applied to  $\mathcal{H}_s$  produces a plug  $\mathcal{H}_m$  whose support  $H_m$  consists of two cubes connected by two handles, rather than the desired two cubes connected by one handle. However, the manifold  $H_m$  can be written as

$$H_m \cong (D^2 \times I) \# (D^2 \times I) \# (S^2 \times S^1).$$

Since there exists a Dehn surgery on  $S^2 \times S^1$  that yields  $S^3$ , there is a way to insert copies of the Dehn-twisted plug  $\mathcal{D}$  into  $\mathcal{H}_m$  to produce a plug with support  $(D^2 \times I) \# (D^2 \times I)$ . This plug is  $\mathcal{H}$ .  $\square$

A PL analogue of  $\mathcal{H}$  also exists; the details are omitted.

#### 4. NO CLOSED TRAJECTORIES

Since the construction of the proof theorem 1 is a modification of a Schweitzer plug, we begin with a brief review of that example.



#### 4.1. Schweitzer's construction

If  $a$  and  $b \neq 0$  are real numbers, let  $a \bmod b$  be the corresponding element in the circle  $\mathbb{R}/b\mathbb{Z}$ . Let  $\tau$  be an irrational real number. Let

$$w(x) = \frac{1}{\pi} \left( \tan^{-1}(x+1) - \tan^{-1}(x) \right)$$

and consider a sequence of open intervals  $I_n$  of length  $|I_n| = w(n)$  placed on the unit circle in the same order as  $n \bmod \tau$ . More specifically, let

$$I_n = (a_n \bmod 1, a_n + w(n) \bmod 1) \subset \mathbb{R}/\mathbb{Z} = S^1,$$

where

$$a_n = \sum_{k: k \bmod \tau \in [0, n \bmod \tau)} w(k).$$

Since the total length of the  $I_n$ 's is exactly 1, they are dense in  $S^1$  but they do not intersect each other. Because of the ordering of the  $I_n$ 's, there exists a homeomorphism  $\alpha : S^1 \rightarrow S^1$  such that  $\alpha(I_n) = I_{n+1}$ . The map  $\alpha$  is a *Denjoy homeomorphism*. It is realized as a  $C^1$  diffeomorphism if its derivative of on  $I_n$  is defined to be

$$\frac{d\alpha}{dx} = 1 + \frac{|I_{n+1}| - |I_n|}{|I_n|} b(L_n(x)),$$

where  $L_n : I_n \rightarrow [0, 1]$  is a linear isomorphism, for those  $n$  such that  $4|I_{n+1}| > 3|I_n|$ . For the finite number of  $n$  such that this inequality fails, let  $\alpha$  be any diffeomorphism from  $I_n$  to  $I_{n+1}$  with derivative 1 at the endpoints. The derivative of  $\alpha$  is 1 outside of the  $I_n$ 's, and since

$$\lim_{n \rightarrow \pm\infty} \frac{|I_{n+1}| - |I_n|}{|I_n|} = 0,$$

the derivative is continuous. The map  $\alpha$  has no periodic orbits and has a unique minimal set, namely  $S^1 - \bigcup_n I_n$ .

Let  $\mathcal{D}$  be the suspension of  $\alpha$  and let  $T$  be its support. The manifold  $T$ , which is a torus because  $\alpha$  preserves orientation, is *a priori* only a  $C^1$  manifold, but it has a smooth refinement such that  $\mathcal{D}$  is parallel to a  $C^1$  vector field  $\vec{D}$ . Let  $m$  be the subset of  $T$  which is the suspension of the minimal set  $S^1 - \bigcup_n I_n$ ;  $m$  is the minimal set of  $\mathcal{D}$ . The set  $m$  is a *Denjoy continuum*.

Consider the manifold  $T \times [-1, 1]$  with the  $[-1, 1]$  factor parameterized by  $z$ . Let  $f$  be a non-negative, non-zero  $C^1$  function on  $T$  which vanishes on  $m$ . Consider a vector field  $\vec{E}$  given by the formula:

$$\vec{E} = \vec{D} + z^2 \frac{\partial}{\partial z} + f \frac{\partial}{\partial z}.$$

By inspection of  $\vec{E}$ , the parallel foliation  $\mathcal{E}$  has no closed leaves, because all leaves either travel in the positive  $z$  direction or coincide with leaves of  $\mathcal{D}$  on  $T \times \{0\}$ . Moreover,  $\mathcal{E}$  has infinite leaves contained in its minimal set  $m \times \{0\}$ . Therefore, by lemma 4,  $\mathcal{E}$  is a semi-plug whose base is a torus. The

mirror-image construction applied to  $\mathcal{E}$  yields a plug  $\mathcal{F}$  which also has no closed leaves and has the same base. We identify the support of  $\mathcal{F}$  with  $T$ .

Since the torus has no boundary,  $\mathcal{F}$  is not insertible. However,  $\mathcal{F}$  also possesses a leaf  $l$  with two endpoints; we can take  $l$  to be the extension of the leaf in  $\mathcal{E}$  containing  $(p, 0)$ , where  $p \in T$  satisfies  $f(p) > 0$ . The leaf  $l$  has a foliated tubular neighborhood  $N_l$  consisting entirely of leaves with two endpoints. The restriction  $\mathcal{S}$  of  $\mathcal{F}$  to  $T \times I - N_l$  is therefore a plug with base  $pT$ , a punctured torus. Since  $l$  is unknotted (which follows from the fact that  $\vec{E}$  is non-negative in the  $z$  direction, and, by the mirror image construction, the leaves in  $N_l$  do not twist around  $l$ ),  $\mathcal{S}$  is an untwisted plug. Following Section 1, copies of  $\mathcal{S}$  can be inserted to break any discrete collection of closed leaves in a foliation. Indeed, as discussed in the appendix, a 3-dimensional plug with a twisted or knotted leaf neighborhood removed can nevertheless be extended to an untwisted, insertible plug. The existence of the plug  $\mathcal{S}$  together with Wilson's theorem (or its variant in Section 3) establishes a counterexample to the usual Seifert conjecture for all 3-manifolds [11].

#### 4.2. Preserving volume

The difficulty in making Schweitzer's construction volume-preserving is the fact that  $\mathcal{D}$  does not possess a transverse measure in the sense of Section 1. Such a measure would induce an  $\alpha$ -invariant measure  $\mu$  on the circle which is locally equivalent to Lebesgue measure. By compactness, the total  $\mu$ -measure of the circle would be finite, but the  $I_n$ 's would have equal and non-zero measure, a contradiction. In other words, any homeomorphism of  $S^1$  conjugate to  $\alpha$  has the inevitable effect of squeezing  $I_n$  as  $n$  goes to  $\infty$  and stretching  $I_n$  as  $n$  comes from  $-\infty$ . Our strategy for overcoming this difficulty is to compensate squeezing of  $I_n$  by stretching in the  $z$  direction. This transverse stretching must be sufficiently slight that there is no net motion in the negative  $z$  direction.

Finding a suitable amount of transverse stretching is the difficult part of Theorem 1 because it is bounded both above and below by different constraints in the construction. One particular problem is that, if the rotation number  $\tau$  of the Denjoy homeomorphism  $\alpha$  is approximated too closely by rationals, orbits of rotation by  $\tau$  are too unevenly distributed for the construction to work. Although any irrational number whose continued fraction expansion has bounded coefficients would work in principle, we let  $\tau = \frac{1+\sqrt{5}}{2}$  be the golden ratio for simplicity. In any case, the construction requires some involved if elementary Diophantine estimates. For convenience, the presence of the constant  $C$  in an equation will mean that there exists a real number  $C > 0$  such that the equation holds. Although  $C$  is independent of all variables, it may have a different value in different equations, or even in different sides of the same equation.

The first step is to construct the Denjoy foliation, or at least its minimal set, in such a way that the underlying torus has a convenient measure. Consider the cylinder  $S^1 \times \mathbb{R}$  parametrized by  $\theta$  and  $\phi$ . Let  $S_n \subset S^1 \times \mathbb{R}$  be a se-

quence of infinite cylindrical strips such that the intersection  $S_n \cap (S^1 \times \{\phi\})$  has length  $w(n - \phi)$  and such that the  $S_n$ 's have the same ordering. Explicitly, let  $I_{n,\phi} \subset S^1 \times \{\phi\}$  be the open interval given by

$$I_{n,\phi} = (a_{n,\phi} \bmod 1, a_{n,\phi} + w(n - \phi) \bmod 1) \\ \subset S^1 \times \mathbb{R} = \mathbb{R}/\mathbb{Z} \times \mathbb{R},$$

where

$$a_{n,\phi} = \sum_{k \bmod \tau \in [0, n \bmod \tau)} w(k - \phi),$$

and let  $S_n$  be the union of all intervals  $I_{n,x}$ . Let  $\sigma : S^1 \times \mathbb{R} \rightarrow S^1 \times \mathbb{R}$  be the homeomorphism given by

$$\sigma(\theta, \phi) = (\theta + a_{1,\phi+1}, \phi + 1).$$

The map  $\sigma$  is smooth, preserves area on  $S^1 \times \mathbb{R}$ , and sends  $S_n$  to  $S_{n+1}$ . The quotient  $T$  of  $S^1 \times \mathbb{R}$  by  $\sigma$  has an open strip  $S$  which is the image of each  $S_n$  under the quotient map, and the volume form  $d\theta \wedge d\phi$  descends to a form  $\mu$  on  $T$ . The complement  $m$  of  $S$  in  $T$  is clearly a Denjoy continuum. In fact, by this definition, the pair  $(T, m)$  is an explicit smooth refinement of the objects of subsection 4.1 with the same name.

Consider  $S^1 \times \mathbb{R} \times [-1, 1]$  with the third coordinate parameterized by  $z$  and with measure  $\mu \wedge dz$ . The next step is to define vector fields  $\vec{h}$  and  $\vec{v}$  on  $S^1 \times \mathbb{R} \times [-1, 1]$  with the following properties:

- (i) They are both invariant under  $\sigma \times id$  and therefore descend to  $T \times [-1, 1]$ .
- (ii) They are both divergenceless  $C^1$  vector fields (relative to  $d\theta \wedge d\phi \wedge dz$  or  $\mu \wedge dz$ ) whose  $\phi$  components vanish.
- (iii) The vector field  $\vec{h} + \frac{\partial}{\partial \phi}$  is parallel to  $m \times \{0\}$ . On the other hand,  $\vec{v}$  vanishes on  $m \times \{0\}$ .
- (iv) The  $z$  component of  $\vec{v}$  is positive except on  $m \times \{0\}$  and exceeds the absolute value of the  $z$  component of  $\vec{h}$ .

Assuming for the moment the existence of  $\vec{v}$  and  $\vec{h}$ , the trajectories of the vector field  $\vec{E}' = \vec{v} + \vec{h} + \frac{\partial}{\partial \phi}$  have the same geometry as those of  $\vec{E}$ ; moreover  $\vec{E}'$  is divergenceless. Following the rest of Schweitzer's construction and the formalism of Section 2, the flux form given by  $\vec{E}'$  yields a measured  $C^1$  plug, which establishes Theorem 1.

We temporarily fix a value of  $\phi$  and work in the coordinates  $\theta$  and  $z$  with the measure  $d\theta \wedge dz$ . Let  $w'(x)$  denote the derivative of  $w(x)$ . Let

$$f(\theta) = \frac{w'(n - \phi)}{w(n - \phi)} b(L_{n,\phi}(\theta))$$

for  $\theta \in I_{n,\phi}$  and 0 elsewhere, where  $L_{n,\phi} : I_{n,\phi} \rightarrow [0, 1]$  is a direction preserving linear isomorphism. Let

$$F(\theta) = w(n - \phi)^{3/2} B(L_{n,\phi}(\theta))$$

for  $\theta \in I_{n,\phi}$  and 0 elsewhere. Define  $\vec{h}$  and  $\vec{v}$  by the equations

$$H(\theta, z) = \frac{1}{2} \int_{\theta-z}^{\theta+z} \int_0^{\theta_1} f(\theta_2) d\theta_2 d\theta_1 \quad (1)$$

$$V(\theta, z) = \frac{C}{z} \int_{\theta-5z}^{\theta+5z} \int_0^{\theta_1} F(\theta_2) d\theta_2 d\theta_1 \quad (2)$$

$$\vec{h} = J(\vec{\nabla} H) = \left( -\frac{\partial H}{\partial z}, \frac{\partial H}{\partial \theta} \right) \\ \vec{v} = J(\vec{\nabla} V) = \left( -\frac{\partial V}{\partial z}, \frac{\partial V}{\partial \theta} \right)$$

extended to  $z = 0$  by continuity.

Except for  $C^1$  continuity, properties (i), (ii), and (iii) are routine. The fact that  $\vec{h}$  is  $C^1$  follows from  $C^2$  continuity of  $H$ , which is immediate from the continuity of  $f$ . The function  $F$  is  $C^1$  as follows: The derivative exists on each  $I_{n,\phi}$ , and it extends continuously to a function  $\tilde{F} : S^1 \rightarrow \mathbb{R}$  which is zero outside of the  $I_{n,\phi}$ 's (check). We claim that  $F$  is the antiderivative of  $\tilde{F}$ . It could only disagree with the antiderivative if it were discontinuous or if the set  $F(S^1 - \bigcup_n I_{n,\phi})$  had non-zero Lebesgue measure, and neither of these is the case. Since  $F$  is  $C^1$ ,  $V$  is  $C^3$  everywhere except where  $z = 0$ ; at such points  $V$  is  $C^2$  by L'Hospital's rule. Therefore  $\vec{v}$  is  $C^1$  also.

Property (iv) is the heart of the matter, and we prove it with a sequence of lemmas. If  $a, b \in \mathbb{R}/\tau\mathbb{Z}$ , let  $Z(a, b)$  be the set of all integers  $n$  such that  $n \bmod \tau \in (a, b)$ , and let  $d(a, b)$  be the distance from  $a$  to  $b$  on the circle  $\mathbb{R}/\tau\mathbb{Z}$ . Here the notation  $(a, b)$  denotes an interval  $(a, b)$  whose endpoints are  $a$  and  $b$  and which is oriented from  $a$  to  $b$  in the natural orientation of the circle.

**Lemma 10.** *Let  $F_n$  be the  $n$ th Fibonacci number, with  $F_0 = F_1 = 1$  and  $F_{n+2} = F_{n+1} + F_n$ . Then*

$$d(F_n \bmod \tau, 0) = \tau^{-n}.$$

*Moreover,  $F_{2n} \bmod \tau$  and  $F_{2n+1} \bmod \tau$  converge to 0 from opposite sides.*

*Proof.* By induction and applying the identity  $\tau^{-1} = \tau - 1$ , we have

$$F_{2n} \bmod \tau = (F_{2n-1} + F_{2n-2}) \bmod \tau \\ = -\tau^{-(2n-1)} + \tau^{-(2n-2)} \\ = \tau^{-(2n-1)}(\tau - 1) = \tau^{-2n},$$

and

$$\tau - F_{2n+1} \bmod \tau = \tau - (F_{2n} + F_{2n-1}) \bmod \tau \\ = \tau - (\tau^{-2n} - \tau^{-(2n-1)} + \tau) \\ = \tau^{-(2n-1)} - \tau^{-2n} \\ = \tau^{-2n}(\tau - 1) = \tau^{-(2n+1)}.$$

□

**Lemma 11.** *If  $0 < p < F_n$ , then*

$$d(F_n \bmod \tau, 0) < d(p \bmod \tau, 0).$$

*Proof.* Applying the identity  $\tau^{-1} = \tau - 1$  inductively to  $\tau^{-n}$  yields

$$\tau^{-n} = (-1)^n (F_n - F_{n-1}\tau).$$

Hence, the lemma can be rephrased as

$$|F_n - \tau F_{n-1}| < |p - \tau q|,$$

for some integer  $q$ . The proof follows now from Theorem 182 of Hardy and Wright [1], since the ratios  $\frac{F_{n-1}}{F_n}$  are the partial evaluations of the continued fraction expansion of  $\tau^{-1}$ .  $\square$

**Lemma 12.** *Let  $n_1$  and  $n_1 + k_1$  be a pair of consecutive elements in  $Z(a, b)$ , and let  $n_2$  and  $n_2 + k_2$  be another such pair. Then  $k_1 < Ck_2$ .*

*Proof.* The case in which  $(a, b)$  is more than half of the circle  $\mathbb{R}/\tau\mathbb{Z}$  is trivial. In the non-trivial case,  $d(a, b)$  is the length of the interval  $(a, b)$ . Choose the largest  $n$  such that  $d(F_n \bmod \tau, 0) > d(a, b)$ . Since  $k_1 \bmod \tau < d(a, b)$ , it follows that  $k_1 > F_n$  by Lemma 11. On the other hand, by Lemma 10, since  $d(F_{n+1} \bmod \tau, 0) < d(a, b)$ ,  $d(F_{n+3} \bmod \tau, 0) < d(a, b)/2$  and  $d(F_{n+4} \bmod \tau, 0) < d(a, b)/2$  also, and  $F_{n+3} \bmod \tau$  and  $F_{n+4} \bmod \tau$  are on opposite sides of 0. At least one of  $k_1 + F_{n+3} \bmod \tau$  and  $k_1 + F_{n+4} \bmod \tau$  is in  $(a, b)$ , since  $k_1 \bmod \tau$  is at least  $d(a, b)/2$  away from one endpoint of  $(a, b)$ . Therefore  $F_n < k_1 \leq F_{n+4}$ , and since  $F_{n+4} < CF_n$  and all arguments also apply to  $k_2$ , the conclusion follows.  $\square$

**Lemma 13.** *If  $0 \notin Z(a, b)$ , then*

$$\sum_{n \in Z(a, b)} \frac{1}{|n|^3} \leq C \frac{\sum_{n \in Z(a, b)} \frac{1}{|n|^5}}{\sum_{n \in Z(a, b)} \frac{1}{n^2}}.$$

*Proof.* Let  $k$  be the element of  $Z(a, b)$  with the least absolute value, and assume without loss of generality that  $k > 0$ . By Lemma 12, the minimum gap between elements of  $Z(a, b)$  is at least  $Ck$ . It follows that

$$\sum_{n \in Z(a, b)} \frac{1}{n^2} \leq 2 \sum_{n=0}^{\infty} \frac{1}{(k + nCk)^2} = \frac{2}{k^2} \sum_{n=0}^{\infty} \frac{C^2}{(C + n)^2} = \frac{C}{k^2}.$$

Therefore,

$$\frac{\sum_{n \in Z(a, b)} \frac{1}{|n|^5}}{\sum_{n \in Z(a, b)} \frac{1}{n^2}} > C \sum_{n \in Z(a, b)} \frac{k^2}{|n|^5} > C \sum_{n \in Z(a, b)} \frac{1}{|n|^3}.$$

$\square$

**Corollary 14.** *For any  $a, b$ , and  $\phi$ ,*

$$\sum_{n \in Z(a, b)} w(n - \phi)^{3/2} \leq C \frac{\sum_{n \in Z(a, b)} w(n - \phi)^{5/2}}{\sum_{n \in Z(a, b)} w(n - \phi)}.$$

*Proof.* The case  $0 \in Z(a, b)$  is trivial; suppose that  $0 \notin Z(a, b)$ . Without loss of generality,  $0 \leq \phi < 1$ , and with this restriction,

$$\frac{C}{n^2} > w(n - \phi) > \frac{C}{n^2}.$$

The inequality renders the corollary equivalent to Lemma 13.  $\square$

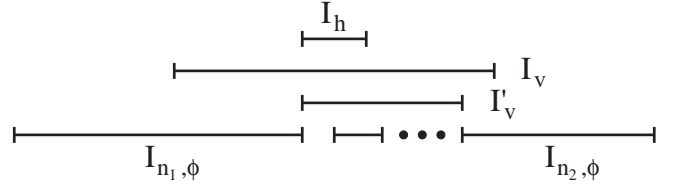

Figure 11: Bounding the length of  $I'_v$

**Lemma 15.** *If  $n_1$  and  $n_2$  are distinct integers, there exists an integer  $n_3$  such that  $n_3 \bmod \tau \in (n_1 \bmod \tau, n_2 \bmod \tau)$  and*

$$|n_3| < C \max(|n_1|, |n_2|)$$

Lemma 15 is a corollary of Lemmas 10 and 11 in the same way as Lemma 12 is.

**Corollary 16.** *If  $n_1$  and  $n_2$  are distinct integers, then the intervals  $I_{n_1, \phi}$  and  $I_{n_2, \phi}$  satisfy*

$$d(I_{n_1, \phi}, I_{n_2, \phi}) > C \max(|I_{n_1, \phi}|, |I_{n_2, \phi}|).$$

*Proof.* Combining the estimate

$$\frac{C}{n^2} > w(n - \phi) > \frac{C}{n^2}$$

with Lemma 15, there exists an  $n_3$  such that  $I_{n_3, \phi}$  lies between  $I_{n_1, \phi}$  and  $I_{n_2, \phi}$  and such that

$$w(n_3 - \phi) > C \min(w(n_1 - \phi), w(n_2 - \phi)).$$

Since the length of  $I_{n, \phi}$  is  $w(n - \phi)$ , the lemma follows from the fact that  $I_{n_1, \phi}$  and  $I_{n_2, \phi}$  are sufficiently far apart to make room for  $I_{n_3, \phi}$ .  $\square$

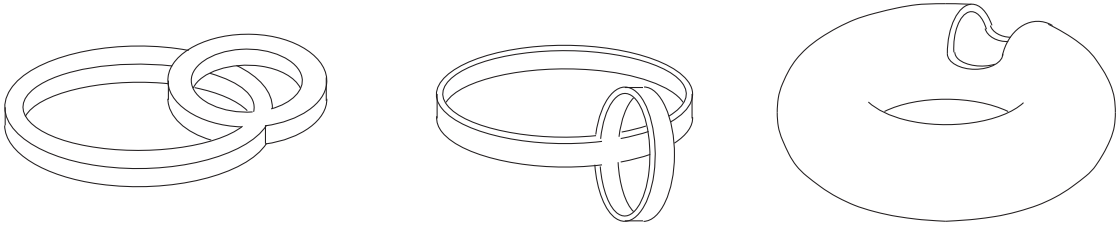

Figure 12: Isotopy of a plug insertion

To establish property (iv), expand  $\vec{v}$  and  $\vec{h}$  as

$$\begin{aligned}\vec{v} &= v_\theta \frac{\partial}{\partial \theta} + v_z \frac{\partial}{\partial z} \\ \vec{h} &= h_\theta \frac{\partial}{\partial \theta} + h_z \frac{\partial}{\partial z}.\end{aligned}$$

It suffices to show that  $v_z > |h_z|$  when  $z \neq 0$ . Once again fix  $\phi$ , and note from equations 1 and 2 that these two quantities are given by

$$\begin{aligned}h_z &= \frac{1}{2} \int_{\theta-z}^{\theta+z} f(\theta_1) d\theta_1 \\ v_z &= \frac{C}{z} \int_{\theta-5z}^{\theta+5z} F(\theta_1) d\theta_1.\end{aligned}$$

The absolute value  $|h_z|$  is also bounded by

$$h_{\text{abs}} = \frac{1}{2} \int_{\theta-z}^{\theta+z} |f(\theta_1)| d\theta_1.$$

Let  $I_v = [\theta - 5z, \theta + 5z]$  be the domain of integration for  $v_z$ , and similarly let  $I_h = [\theta - z, \theta + z]$ . One possibility is that  $I_h$  is a subset of some  $I_{n,\phi}$ . In this case, the inequalities

$$z < |I_{n,\phi}|$$

$$B(x) > b(x)$$

$$Cw(n - \phi)^{3/2} > |w'(n - \phi)|$$

together imply that  $v_z > h_{\text{abs}}$ .

Alternatively, suppose that  $I_h$  does not lie in a single  $I_{n,\phi}$ . Let  $I'_v$  be the closure of the union of all  $I_{n,\phi}$ 's which are contained in  $I_v$ . Since  $I_h$  is the middle fifth of  $I_v$ , and since the integrand of  $h_{\text{abs}}$  is only non-zero in the middle third of an interval  $I_{n,\phi}$ , the integrand of  $h_{\text{abs}}$  is zero in the region in  $I_h - I'_v$ . I.e.,

$$h_{\text{abs}} \leq \int_{I'_v} |f(\theta_1)| d\theta_1. \quad (3)$$

The region  $I_v - I'_v$  in general consists of a subinterval of some interval  $I_{n_1,\phi}$  on one side and a subinterval of some other interval  $I_{n_2,\phi}$  on the other side. By hypothesis,  $I'_v$  contains at

least one point in  $I_h$ , which is the middle fifth of  $I_v$ , and therefore if  $|I'_v| < C|I_v| = Cz$ , then the intervals  $I_{n_1,\phi}$  and  $I_{n_2,\phi}$  both have length at least  $Cz$ . (See Figure 11.) It follows by Corollary 16 that  $|I'_v| > Cz$  and that

$$v_z > \frac{C}{|I'_v|} \int_{I'_v} F(\theta_1) d\theta_1. \quad (4)$$

In the main case, the set  $Z_v$  of all  $n$  such that  $I_{n,\phi} \subset I'_v$  is exactly a  $Z(a, b)$ . In this case, the right sides of equations 3 and 4 are related by Corollary 14, which demonstrates that  $v_z > h_{\text{abs}}$ , as desired. The alternative possibilities are that  $a = n_a \bmod \tau$  or that  $b = n_b \bmod \tau$  and that  $Z_v$  is  $Z(a, b)$  union  $\{n_a\}$  or  $\{n_b\}$  or both; these exceptional cases can be treated in the same way as the main case.

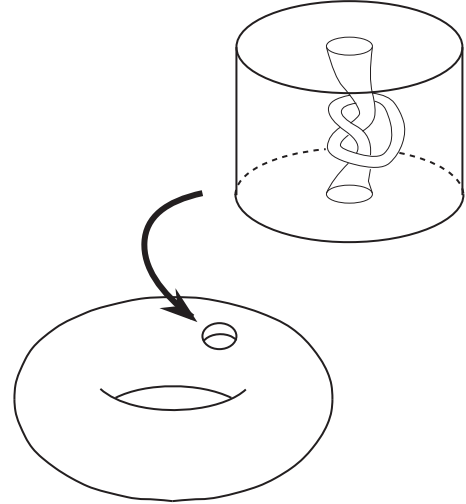

Figure 13: A plug with a knotted hole

## 5. APPENDIX: PLUGS WITH KNOTTED HOLES

The Schweitzer construction and its modifications here and in the work of Harrison [3] suggest but do not depend on the following question: Suppose that  $\mathcal{P}$  is a plug whose base is a closed, oriented surface and suppose that  $\mathcal{P}$  has a knotted leaf with two endpoints. Let  $N_l$  be a foliated tubular neighborhood of  $l$  and let  $\mathcal{P}_l$  be  $\mathcal{P}$  with  $N_l$  removed. Since  $\mathcal{P}_l$  is twisted,

can it be inserted into a foliation of  $M$  without changing the topology of  $M$ ?

In Harrison's construction, the base of  $\mathcal{P}$  is a torus and, moreover,  $\mathcal{P}$  is a slanted suspension (in the  $C^2$  category) of a homeomorphism of an annulus, made into a plug with the mirror-image construction. In this case, following Harrison, there exists a finite cover of  $\mathcal{P}$  such that a lift of  $l$  is necessarily unknotted, and by the mirror-image construction  $N_l$  is necessarily untwisted.

Taking the general case, suppose that the base of  $\mathcal{P}$  is  $S$ ; the base of  $\mathcal{P}_l$  is therefore  $pS$ , or  $S$  with one puncture. Let  $P_l$  be the support of  $\mathcal{P}_l$ . Consider Schweitzer's insertion of  $\mathcal{P}_l$  into the un-plug with base a disk  $D^2$  in Figure 12a. If  $\mathcal{P}_l$  were an

untwisted plug, its insertion would be realized by an embedding  $\alpha$  of  $pS \times I$  which is a thickening of the insertion map for the base. Ignoring the vertical foliation on  $D^2 \times I$ , this embedding is isotopic to the standard embedding of the closed surface  $S$ , punctured and thickened, as shown in Figure 12b and Figure 12c. The complement  $(D^2 \times I) - \alpha(pS \times I)$  is topologically the exterior of a solid torus connected by a handle to a solid torus. Recognizing  $P_l$  as  $S \times I$  with a knotted hole, it admits an embedding  $\beta$  in  $D^2 \times I$  whose complement is homeomorphic to the complement of  $\alpha(pS \times I)$ , as shown in Figure 13. Since the complements are the same, the insertion of  $\mathcal{P}_l$  does not change the topology of  $D^2 \times I$  even though  $\mathcal{P}_l$  is twisted.

- 
- [1] G. H. Hardy and E. M. Wright, *An Introduction to the Theory of Numbers*. Oxford University Press, Oxford, 1979.
- [2] D. Hart, *On the smoothness of generators*, Topology 22 (1983), 357-363.
- [3] J. Harrison,  *$C^2$  counterexamples to the Seifert conjecture*, Topology 27 (1988), 249-278.
- [4] H. Hofer, *Pseudoholomorphic curves in symplectizations with applications to the Weinstein conjecture in dimension three*, preprint.
- [5] K. Kuperberg, *A smooth counterexample to the Seifert conjecture*, Ann. of Math. 140 (1994), 723-732.
- [6] G. Kuperberg and K. Kuperberg, *Generalized counterexamples to the Seifert conjecture*, preprint.
- [7] J. Moser, *On the volume elements of a manifold*, Trans. Amer. Math. Soc. 120 (1965), 286-294.
- [8] B. Dacorogna and J. Moser, *On a partial differential equation involving the Jacobian determinant*, Ann. Inst. H. Poincaré Anal. Non-Linear 7 (1990) no. 1, 1-26.
- [9] J. F. Plante, *Foliations with measure-preserving holonomy*, Ann. of Math. 102 (1975), 327-361.
- [10] D. Rolfsen, *Knots and Links*, volume 7 of *Mathematics Lecture Series*. Publish or Perish, Inc., Wilmington, DE, 1976.
- [11] P. A. Schweitzer, *Counterexamples to the Seifert conjecture and opening closed leaves of foliations*, Ann. of Math. 100 (1974), 386-400.
- [12] H. Seifert, *Closed integral curves in 3-space and isotopic two-dimensional deformations*, Proc. Amer. Math. Soc. 1 (1950), 287-302.
- [13] W. P. Thurston, private communication.
- [14] A. Weinstein, *On the hypothesis of Rabinowitz's periodic orbit theorems*, J. Diff. Eq. 33 (1979), 353-358.
- [15] F. W. Wilson, *On the minimal sets of non-singular vector fields*, Ann. of Math. 84 (1966), 529-536.