

Duality Theorem and Drinfeld Double in Braided Tensor Categories *

Shouchuan Zhang

Department of Mathematics, Hunan University, Changsha 410082, P.R.China

E-mail:z9491@yahoo.com.cn

Abstract

Let H be a finite Hopf algebra with $C_{H,H} = C_{H,H}^{-1}$. The duality theorem is shown for H , i.e.,

$$(R\#H)\#H^* \cong R \otimes (H\bar{\otimes}H^*) \quad \text{as algebras in } \mathcal{C}.$$

Also, it is proved that the Drinfeld double $(D(H), [b])$ is a quasi-triangular Hopf algebra in \mathcal{C} .

2000 Mathematics subject Classification: 16w30.

Keywords: Hopf algebra, braided tensor category, duality theorem, Drinfeld double.

1 Introduction and Preliminaries

It is well-known that in the work of C^* -algebras and von Neumann algebras, for an abelian group G , the product of R crossed by G crossed by \hat{G} is isomorphic to the tensor product of R and the compact operator. Its generalization to Hopf-von Neumann algebras was known again. (see, for example, Stratila [13]). Blattner and Montgomery strip off the functional analysis and duplicate the result at the level of Hopf algebras (see [2] and [11]). They proved that for an ordinary Hopf algebra H and some subalgebra U of H^* ,

$$(R\#H)\#U \cong R \otimes (H\#U) \quad \text{as algebras} \quad .$$

The basic construction of the Drinfeld double is due to Drinfeld [4]. S.Majid [7] and D.E.Radford [12] modified the treatment.

In this paper, we generalize the duality theorem and Drinfeld double into the braided case, i.e., for a finite Hopf algebra H with $C_{H,H} = C_{H,H}^{-1}$, we show that

$$(R\#H)\#H^* \cong R \otimes (H\bar{\otimes}H^*) \quad \text{as algebras in } \mathcal{C}$$

We also show that the Drinfeld double $(D(H), [b])$ is a quasi-triangular Hopf algebra in \mathcal{C} .

*This work is supported by National Science Foundation (No. 19971074)

In this paper, $(\mathcal{C}, \otimes, I, C)$ is always a braided tensor category, where I is the identity object and C is the braiding.

By [16, Theorem 0.1], we can view every braided tensor category as a strict braided tensor category.

For an object V in \mathcal{C} , if there exists an object U and morphisms $d_V : U \otimes V \rightarrow I$ and $b_V : I \rightarrow V \otimes U$ in \mathcal{C} such that $(d_V \otimes id_U)(id_U \otimes b_V) = id_U$ and $(id_V \otimes d_V)(b_V \otimes id_V) = id_V$, then U is called a left dual of V , written as V^* . In this case, d_V and b_V are called the evaluation morphism and coevaluation morphism of V , respectively. In general, we use d and b instead of d_V and b_V . Furthermore, V is said to be finite if V has a left dual (see [15]).

Let us define the transpose $f^* = (d \otimes id_{U^*})(id_{V^*} \otimes f \otimes id_{U^*})(id_{V^*} \otimes b) : V^* \rightarrow U^*$ of a morphism $f : U \rightarrow V$.

Let $\Delta^{cop} = C_{H,H}\Delta$ and $m^{op} = mC_{H,H}$. We denote $(H, \Delta^{cop}, \epsilon)$ by H^{cop} and (H, m^{op}, η) by H^{op} . Furthermore we denote $((H^*)^{op})^{cop}$ by H^* .

A bialgebra $(H, R, \bar{\Delta})$ with convolution-invertible R in $Hom_{\mathcal{C}}(I, H \otimes H)$ is called a quasi-triangular bialgebra in \mathcal{C} if $(H, \bar{\Delta}, \epsilon)$ is a coalgebra and the following conditions are satisfied:

- (QT1) $(\bar{\Delta} \otimes id)R = (id \otimes id \otimes m)(id \otimes R \otimes id)R$;
- (QT2) $(id \otimes \bar{\Delta})R = (m \otimes id \otimes id)(id \otimes R \otimes id)R$;
- (QT3) $(m \otimes m)(id \otimes C_{H,H} \otimes id)(\bar{\Delta} \otimes R) = (m \otimes m)(id \otimes C_{H,H} \otimes id)(R \otimes \bar{\Delta})$.

In this case, we also say that $(H, R, \bar{\Delta})$ is a braided quasi-triangular bialgebra.

Dually, we can define a coquasi-triangular bialgebra (H, r, \bar{m}) in the braided tensor category \mathcal{C} .

In particular, we say that (H, R) is quasi-triangular if (H, R, Δ^{cop}) is quasi-triangular. Dually, we say that (H, r) is coquasi-triangular if (H, r, m^{op}) is coquasi-triangular.

A morphism τ from $H \otimes A$ to I in \mathcal{C} is called a skew pairing on $H \otimes A$ if the following conditions are satisfied:

- (SP1): $\tau(m \otimes id) = \tau(id \otimes \tau \otimes id)(id \otimes id \otimes \Delta)$;
- (SP2): $\tau(id \otimes m) = (\tau \otimes \tau)(id \otimes C_{H,A} \otimes id)(\Delta \otimes id \otimes id)$;
- (SP3): $\tau(id \otimes \eta) = \epsilon_H$;
- (SP4): $\tau(\eta \otimes id) = \epsilon_A$.

If a morphism τ from $V \otimes W$ to I in \mathcal{C} satisfies

$$(id_U \otimes \tau)(C_{V,U} \otimes id_W) = (\tau \otimes id_U)(id_V \otimes C_{U,W})$$

for $U = V, W$, then τ is said to be symmetric with respect to the braiding C .

Lemma 1.1 *If H has a left dual H^* , then the following conditions are equivalent:*

- (i) *The evaluation of H is symmetric with respect to the braiding C .*
- (ii) $C_{U,V} = C_{V,U}^{-1}$ for $U, V = H$ or H^* .
- (iii) $C_{H,H} = C_{H,H}^{-1}$.
- (iv) $C_{H^*,H^*} = C_{H^*,H^*}^{-1}$.
- (v) $(id_H \otimes d)(C_{H^*,H} \otimes id_H) = (d \otimes id_H)(id_{H^*} \otimes C_{H,H})$.
- (vi) $(id_{H^*} \otimes d)(C_{H^*,H^*} \otimes id_H) = (d \otimes id_{H^*})(id_{H^*} \otimes C_{H^*,H})$.

Proof. It is straightforward. \square

2 The Duality Theorem

In this section, we obtain the duality theorem for Hopf algebras living in the braided tensor category \mathcal{C} .

Throughout this section, H is a finite Hopf algebra with $C_{H,H} = C_{H,H}^{-1}$ living in \mathcal{C} . (R, α) is a left H -module algebra in \mathcal{C} and $R\#H$ is the smash product in \mathcal{C} . Let $H^{\hat{*}} = ((H^*)^{op})^{cop}$.

The proof of Lemmas 2.1 —2.7 is very similar to that of corresponding results in [11].

Lemma 2.1 *If (R, α) is an H -module algebra, let $\phi = (id \otimes \alpha)(b' \otimes id) : R \rightarrow H^*{}^{op} \otimes R$, where $b' = C_{H,H^*}{}^{op}b$. Then*

$$\phi m = (m \otimes m)(id \otimes C_{R,H^*}{}^{op} \otimes id)(\phi \otimes \phi).$$

Lemma 2.2 (1) (H, \rightharpoonup) is a left $H^{\hat{*}}$ -module algebra under the module operation $\rightharpoonup = (id \otimes d)(C_{H^{\hat{*}},H} \otimes id)(id \otimes \Delta)$.

(2) $(H^{\hat{*}}, \rightharpoonup)$ is a left H -module algebra under the module operation $\rightharpoonup = (id \otimes d)(id \otimes C_{H,H^{\hat{*}}})(C_{H,H^{\hat{*}}} \otimes id)(id \otimes \Delta)$.

(3) (H, \leftharpoonup) is a right $H^{\hat{*}}$ -module algebra under the module operation $\leftharpoonup = (d \otimes id)(C_{H,H^{\hat{*}}} \otimes id)(id \otimes C_{H,H^{\hat{*}}})(\Delta \otimes id)$.

(4) $(H^{\hat{*}}, \leftharpoonup)$ is a right H -module algebra under the module operation $\leftharpoonup = (d \otimes id)(id \otimes C_{H^{\hat{*}},H})(\Delta \otimes id)$.

Lemma 2.3 *The object $H \otimes H^{\hat{*}}$ becomes an algebra, written as $H \bar{\otimes} H^{\hat{*}}$, under the multiplication $m_{H \bar{\otimes} H^{\hat{*}}} = (id_H \otimes d \otimes id_{H^{\hat{*}}})$ and unity $\eta_{H \bar{\otimes} H^{\hat{*}}} = b$.*

In fact, if \mathcal{C} is a braided tensor category determined by the (co)quasi-triangular structure of a (co)quasi-triangular Hopf algebra over a field k , then $H \bar{\otimes} H^{\hat{*}}$ can be viewed as $End_k(H)$ or $M_n(k) = \{A \mid A \text{ is an } n \times n \text{ matrix over the field } k\}$.

Lemma 2.4 *Let $\lambda = (m \otimes d \otimes id)(id \otimes C_{H^{\hat{*}},H} \otimes id \otimes id)(id \otimes id \otimes \Delta \otimes id)(id \otimes id \otimes b)$ and $\rho = (d \otimes m \otimes id)(id \otimes id \otimes C_{H,H} \otimes id)(id \otimes C_{H,H} \otimes id \otimes id)(id \otimes id \otimes \Delta \otimes id)(id \otimes id \otimes b)$. Then λ is an algebra morphism from $H \# H^{\hat{*}}$ to $H \bar{\otimes} H^{\hat{*}}$ and ρ is an anti-algebra morphism from $H^{\hat{*}} \# H$ to $H \bar{\otimes} H^{\hat{*}}$.*

Lemma 2.5 *The following relation holds: $m(\lambda \otimes \rho) = m(\rho \otimes \lambda)(id \otimes \rightharpoonup \otimes \leftharpoonup \otimes id)(id \otimes C_{H,H^{\hat{*}}} \otimes C_{H^{\hat{*}},H} \otimes id)(id \otimes id \otimes C_{H^{\hat{*}},H^{\hat{*}}} \otimes id \otimes id)(id \otimes C_{H^{\hat{*}},H} \otimes C_{H,H^{\hat{*}}} \otimes id)(C_{H^{\hat{*}},H^{\hat{*}}} \otimes id \otimes id \otimes C_{H^{\hat{*}},H^{\hat{*}}})(S \otimes id \otimes id \otimes id \otimes id \otimes id)(\Delta \otimes id \otimes id \otimes \Delta)(id \otimes C_{H,H} \otimes id)(C_{H,H^{\hat{*}}} \otimes C_{H^{\hat{*}},H})(id \otimes C_{H^{\hat{*}},H^{\hat{*}}} \otimes id)$.*

Lemma 2.6 *If the antipode of H is invertible, then λ is invertible.*

Lemma 2.7 $R\#H$ becomes an H^* -module algebra under the module operation $\dashv' = (id \otimes \dashv)(C_{H^*,R} \otimes id)$.

Theorem 2.8 If H is a finite Hopf algebra with $C_{H,H} = C_{H,H}^{-1}$, then

$$(R\#H)\#H^{\hat{*}} \cong R \otimes (H\bar{\otimes}H^{\hat{*}}) \quad \text{as algebras in } \mathcal{C},$$

Where $H\bar{\otimes}H^{\hat{*}}$ is defined in Lemma 2.3.

Proof. We first define a morphism w from $H^{\hat{*}}$ to $H\#H^{\hat{*}}$ such that $w = \lambda^{-1}\rho(S^{-1} \otimes \eta_H)$; this can be done by Lemma 2.6 and [15, Theorem 4.1]. Since ρ and S^{-1} are anti-algebra morphisms, w is an algebra morphism. Set $\phi = (id \otimes \alpha)(C_{H,H^{\hat{*}}} \otimes id)(b \otimes id)$.

We now define a morphism $\Phi = (id \otimes m_{H\#H^{\hat{*}}})(id \otimes w \otimes id \otimes id)(C_{H^{\hat{*}},R} \otimes id \otimes id)(\phi \otimes id \otimes id)$ from $(R\#H)\#H^{\hat{*}}$ to $R \otimes (H\bar{\otimes}H^{\hat{*}})$ and a morphism $\Psi = (id \otimes m_{H\#H^{\hat{*}}})(id \otimes w \otimes id \otimes id)(C_{H^{\hat{*}},R} \otimes id \otimes id)(S \otimes id \otimes id \otimes id)(\phi \otimes id \otimes id)$ from $R \otimes (H\bar{\otimes}H^{\hat{*}})$ to $(R\#H)\#H^{\hat{*}}$. It is straightforward to verify that $\Phi\Psi = id$ and $\Psi\Phi = id$.

To see that Φ is an algebra morphism, we only need to show that $\Phi' = (id \otimes \lambda)\Phi$ is an algebra morphism. Set $\xi = (id \otimes \rho)(S^{-1} \otimes \eta_H)C_{H^{\hat{*}},R}\phi$, which is a morphism from R to $R \otimes (H\bar{\otimes}H^{\hat{*}})$. We have that ξ is an algebra morphism and $\Phi' = (id \otimes m)(\xi \otimes \lambda)$. Using Lemma 2.5, we can show that $(id \otimes m)(C_{H\bar{\otimes}H^{\hat{*}},R} \otimes id)(\lambda \otimes \xi) = (id \otimes m)(\xi \otimes \lambda)(\alpha \otimes id \otimes id)(id \otimes C_{H,R} \otimes id)(id \otimes id \otimes C_{H^{\hat{*}},R})(\Delta \otimes id \otimes id)$. Applying this, we see that Φ' is an algebra morphism. \square

3 Drinfeld Double

In this section, we construct the Drinfeld double $D(H)$ for a finite Hopf algebra H with $C_{H,H} = C_{H,H}^{-1}$ in the braided tensor category \mathcal{C} . We show that $(D(H), [b])$ is quasi-triangular.

Theorem 3.1 Let H and A be two bialgebras in \mathcal{C} . Assume that τ is an invertible skew pairing on $H \otimes A$ and symmetric with respect to the braiding. If we define $\alpha = (\tau \otimes id \otimes \bar{\tau})(id \otimes id \otimes C_{H,A} \otimes id)(id \otimes C_{H,A} \otimes \Delta)(\Delta \otimes \Delta)$ and $\beta = (\tau \otimes id \otimes \bar{\tau})(id \otimes C_{H,A} \otimes id \otimes id)(\Delta \otimes C_{H,A} \otimes id)(\Delta \otimes \Delta)$, then the double cross product $A_\alpha \bowtie_\beta H$, defined in [16, P36]), of A and H is an algebra and a coalgebra. If A and H are Hopf algebras, then $A_\alpha \bowtie_\beta H$ has an antipode. Furthermore, $A_\alpha \bowtie_\beta H$ is a bialgebra if and only if $C_{A,H}C_{H,A} = id$.

Proof. We can check that (A, α) is an H -module coalgebra and (H, β) is an A -module coalgebra step by step. We can also check that (M1)–(M3) in [16, P36–37] hold step by step. Consequently, it follows from [16, Corollary 1.8, Theorem 1.5] that $A_\alpha \bowtie_\beta H$ is an algebra and a coalgebra. Observing the proof of [16, Theorem 1.5], we know that the condition (M4) is not needed in the proof. Consequently, $A_\alpha \bowtie_\beta H$ has an antipode.

From [1, Proposition 3.6], we obtain our last assertion. \square

In this case, $A_\alpha \bowtie_\beta H$ can be written as $A \bowtie_\tau H$ and called a double cross product.

Theorem 3.2 *Let H be a finite Hopf algebra with $C_{H,H} = C_{H,H}^{-1}$. Set $A = (H^*)^{op}$ and $\tau = d_H C_{H,A}$. Then $(D(H), [b])$ is a quasi-triangular Hopf algebra in \mathcal{C} with $[b] = \eta_A \otimes b \otimes \eta_H$ and $D(H) = A \bowtie_{\tau} H$, called the Drinfeld double of H .*

Proof. Using [8, Proposition 2.4] or the definition of the evaluation and coevaluation on tensor product, we can obtain that τ is a skew pairing on $H \otimes A$ and $[b]$ satisfies (QT1) and (QT2). For (QT3), see that $(m \otimes m)(id \otimes C_{D(H),D(H)} \otimes id)(\Delta^{cop} \otimes [b]) = (id \otimes id \otimes m \otimes id)(id \otimes C_{A,H} \otimes id \otimes id)(id \otimes id \otimes m \times id \otimes id)(id \otimes id \otimes id \otimes m \times id \otimes id)(id \otimes id \otimes id \otimes m \times id \otimes id)(C_{A,A} \otimes id \otimes id \otimes C_{H,H} \times C_{H,A})(id \otimes id \otimes id \otimes C_{H,H} \otimes C_{H,H} \otimes id)(id \otimes id \otimes C_{H,H} \otimes C_{H,H} \otimes b)(id \otimes id \otimes id \otimes C_{H,H} \otimes S^{-1})(\Delta \otimes \Delta \otimes C_{H,H})(id \otimes \Delta \otimes id)(id \otimes \Delta) = (id \otimes C_{A,H} \otimes id)(id \otimes m \otimes id \otimes id)(C_{A,A} \otimes C_{H,A} \otimes id)(id \otimes id \otimes m \otimes id \otimes id)(id \otimes id \otimes C_{H,H} \otimes C_{H,A})(id \otimes id \otimes id \otimes C_{H,H} \otimes id)(\Delta \otimes \Delta \otimes b)$ and $(m \otimes m)(id \otimes C_{D(H),D(H)} \otimes id)([b] \otimes \Delta) = (id \otimes m \otimes id \otimes id)(C_{H,A} \otimes C_{A,H} \otimes id)(id \otimes id \otimes m \otimes id \otimes id)(id \otimes id \otimes m \otimes id \otimes id \otimes id)(id \otimes id \otimes m \otimes id \otimes id \otimes id)(id \otimes C_{A,A} \otimes id \otimes S \otimes id \otimes id \otimes id)(id \otimes id \otimes C_{A,A} \otimes id \otimes id \otimes id \otimes id)(id \otimes C_{A,A} \otimes \Delta \otimes id \otimes id \otimes id)(b \otimes \Delta \otimes id \otimes id \otimes id)(\Delta \otimes \Delta) = (id \otimes C_{A,H} \otimes id)(id \otimes m \otimes id \otimes id)(C_{A,A} \otimes C_{H,A} \otimes id)(id \otimes id \otimes m \otimes id \otimes id)(id \otimes id \otimes C_{H,H} \otimes C_{H,A})(id \otimes id \otimes m \otimes id \otimes id)(id \otimes id \otimes C_{H,H} \otimes id)(\Delta \otimes \Delta \otimes b)$. Thus (QT3) holds. \square

In fact, there exists a very closed relation between the Drinfeld double $D(H)$ defined in Theorem 3.2 and the Drinfeld double $\mathcal{D}(H)$ defined in [3]. Since $C_{H^*,H} : D(H) = H^{*op} \bowtie_{\tau} H \longrightarrow \mathcal{D}(H^{op}) = H^{op} \bowtie_d H^*$ is an anti-algebra isomorphism and a coalgebra isomorphism, we have $D(H) \cong \mathcal{D}(H^{op})^{op}$ as Hopf algebras in \mathcal{C} .

4 Example

In this section, using preceding conclusions, we give some examples for the duality theorem and Drinfeld double in a braided tensor category \mathcal{C} .

Proposition 4.1 *(See [6, Definition 2.8 (R2)]) A χ -Hopf algebra H is a Hopf algebra living in the braided tensor category $({}^k G \mathcal{M}, C^r)$, where $r(g, h) = v^{\chi(g,h)}$ for any $g, h \in G$; χ is a map from $G \times G$ to \mathbf{Z} with $\chi(a, b) = \chi(b, a)$ and $\chi(a + b, c) = \chi(a, c) + \chi(b, c)$ for any $a, b, c \in G$.*

It follows from the preceding proposition and [6, Ex. 2.12, Section 3] that Lusztig's algebra $'f$, the twisted Ringel-Hall algebra and Ringel's composition algebra are all Hopf algebras in braided tensor categories.

Example 4.2 *The bilinear map τ , defined in [5, Pro. 1.2.3], of Lusztig's algebra $'f$ is symmetric with respect to the braiding.*

Proof. For any homogeneous elements $x, y, z \in 'f$, we have that $(\tau \otimes id)(id \otimes C_{'f, 'f})(x \otimes y \otimes z) = \tau(x, z)v^{|y| \cdot |z|} \delta_{|x|, |z|} = \tau(x, z)v^{|y| \cdot |x|} \delta_{|x|, |z|} = (id \otimes \tau)(C_{'f, 'f} \otimes id)(x \otimes y \otimes z)$. \square

Example 4.3 (see [9, Example 9.4.9]) The evaluation of the braided group analogue \underline{H} of an ordinary coquasi-triangular cocommutative Hopf algebra (H, r) is symmetric with respect to braiding C^r . In particular, the above conclusion holds for $H = kG$.

Proof. It is straightforward. \square

Example 4.4 Let H denote Lusztig's algebra 'f. If $A = 'f^{op}$, then the bilinear map τ as in Example 4.2 is a skew pairing on $H \otimes A$ and symmetric with respect to the braiding. Thus, by Theorem 3.1, $A \bowtie_{\tau} H$ is an algebra and a coalgebra with an antipode in $({}^{k\mathbf{Z}^n} \mathcal{M}, C^r)$, but it is never a bialgebra in $({}^{k\mathbf{Z}^n} \mathcal{M}, C^r)$ since $C_{A,H} C_{H,A} \neq id$.

It has been known that the category of comodules of every ordinary coquasi-triangular Hopf algebra is a braided tensor category. For example, let $H = \mathbf{CZ}_n$ and $r(a, b) = (e^{\frac{2\pi i}{n}})^{ab}$ for any $a, b \in \mathbf{Z}_n$, where \mathbf{C} is the complex field. It is clear that (\mathbf{CZ}_n, r) is a coquasi-triangular Hopf algebra. Thus, $(\mathbf{CZ}_n \mathcal{M}, C^r)$ is a braided tensor category, usually written as \mathcal{C}_n . Every algebra or Hopf algebra living in \mathcal{C}_n is called an anyonic algebra or anyonic Hopf algebra (see [9, Example 9.2.4]). Every algebra or Hopf algebra living in \mathcal{C}_2 is called a superalgebra or super-Hopf algebra. In particular, \mathcal{C}_n is a strictly braided tensor category when $n > 2$.

It follows from Theorem 3.2 that

Corollary 4.5 (Duality Theorem) Let H be a finite dimensional Hopf algebra with $C_{H,H} = C_{H,H}^{-1}$ in (\mathcal{C}, C) . Then

$$(R \# H) \# H^{\hat{*}} \cong M_n(R) \quad \text{as algebras in } (\mathcal{C}, C)$$

in the following three cases:

- (i) (\mathcal{C}, C) is the braided tensor category $({}^B \mathcal{M}, C^R)$ determined by the quasi-triangular structure R ;
- (ii) (\mathcal{C}, C) is the braided tensor category $({}^B \mathcal{M}, C^r)$ determined by the coquasi-triangular structure r
- (iii) (\mathcal{C}, C) is the braided tensor category ${}^B_B \mathcal{YD}$ or ${}_B \mathcal{YD}^B$ of Yetter-Drinfeld modules.

Example 4.6 (see [10]) Let A denote the anyonic line algebra, i.e., $A = \mathbf{C}\{x\}/\langle x^n \rangle$, where $\mathbf{C}\{x\}$ is a free algebra over the complex field \mathbf{C} and $\langle x^n \rangle$ is an ideal generalized by x^n of $\mathbf{C}\{x\}$. Set $\mathbf{C}[\xi] = \mathbf{C}\{x\}/\langle x^n \rangle$ with $\xi^n = 0$. Its comultiplication, counit, and antipode are

$$\Delta(\xi) = \xi \otimes 1 + 1 \otimes \xi, \quad \epsilon(\xi) = 0, \quad \text{and} \quad S(\xi) = -\xi,$$

respectively. It is straightforward to check that H is an anyonic Hopf algebra. Let H denote the braided group analogue $\underline{\mathbf{CZ}}_n$ of \mathbf{CZ}_n . Since \mathbf{CZ}_n is commutative, we have $C_{\mathbf{CZ}_n, \mathbf{CZ}_n} = C_{\underline{\mathbf{CZ}}_n, \underline{\mathbf{CZ}}_n}^{-1}$. Let H act on A trivially. By Corollary 4.5, we have

$$(\mathbf{C}[\xi] \# \underline{\mathbf{CZ}}_n) \# (\underline{\mathbf{CZ}}_n)^{\hat{*}} \cong M_n(\mathbf{C}[\xi]) \quad \text{as algebras in } ({}^{\mathbf{CZ}_n} \mathcal{M}, C^r).$$

By the way, we also have that the Drinfeld double of $\underline{\mathbf{CZ}}_n$ is quasi-triangular in $({}^{\mathbf{CZ}_n} \mathcal{M}, C^r)$ with the quasi-triangular structure [b].

Acknowledgement The author thanks the referee and the editor for valuable suggestions.







References

- [1] Y. Bespalov and B.Drabant, Cross product bialgebras, I, *J. algebra*, **219** (1999), 466–505.
- [2] R. J. Blattner and S. Montgomery, A duality theorem for Hopf module algebras, *J. algebra*, **95** (1985), 153–172.
- [3] H.X.Chen, Quantum double in monoidal categories, *Comm.Algebra*, **28** (2000)5, 2303–2328.
- [4] V. G. Drinfeld, Quantum groups, in “Proceedings International Congress of Mathematicians, August 3-11, 1986, Berkeley, CA” pp. 798–820, Amer. Math. Soc., Providence, RI, 1987.
- [5] G.Lusztig, Introduction to Quantum Groups, *Progress on Math.*, Vol.110, Birkhauser, Berlin, 1993.
- [6] L.Li and P.Zhang, Twisted Hopf algebras, Ringel-Hall algebras and Green’s categories, *J.Algebra*, **231**(2000), P713–743.
- [7] S. Majid, Physics for algebraists: Non-commutative and non-cocommutative Hopf algebras by a bicrossproduct construction, *J.Algebra* **130** (1990), 17–64.
- [8] S. Majid, Algebras and Hopf algebras in braided categories, *Lecture notes in pure and applied mathematics advances in Hopf algebras*, Vol. 158, edited by J. Bergen and S. Montgomery, Marcel Dekker, New York, 1994, 55–105.
- [9] S. Majid, *Foundations of Quantum Group Theory*, Cambridge University Press, Cambridge, 1995.
- [10] S. Majid and M.J. Rodriguez Piazza, Random walk and the heat equation on superspace and anyspace, *J. Math. Phys.*, **35**(1994) 7, 3753–3760.
- [11] S. Montgomery, *Hopf Algebras and Their Actions on Rings*. CBMS Number 82, AMS, Providence, RI, 1993.
- [12] D. E. Radford, Minimal quasi-triangular Hopf algebras, *J. algebra*, **157** (1993), 281–315.
- [13] S. Stratila, *Modular Theory in Operator Algebras*, Editura Academiei and Abacus Press, Bucuresti, 1981.
- [14] M.E.Sweedler, *Hopf Algebras*, Benjamin, New York, 1969.

- [15] M. Takeuchi, Finite Hopf algebras in braided tensor categories , J.Pure and Applied Algebra, **138**(1999), 59-82.
- [16] Shouchuan Zhang, Hui-Xiang Chen, The double bicrossproducts in braided tensor categories, Communications in Algebra, **29**(2001)1, P31–66.

5 Appendix

We denote the multiplication, comultiplication, antipode, braiding and inverse braiding by

,
 
,
 
,
 
 and
 
, respectively. In particular, we denote $C_{U,V}$ by , for any $U, V = H$ or H^*

The proof of Lemma 2.4
 Proof.

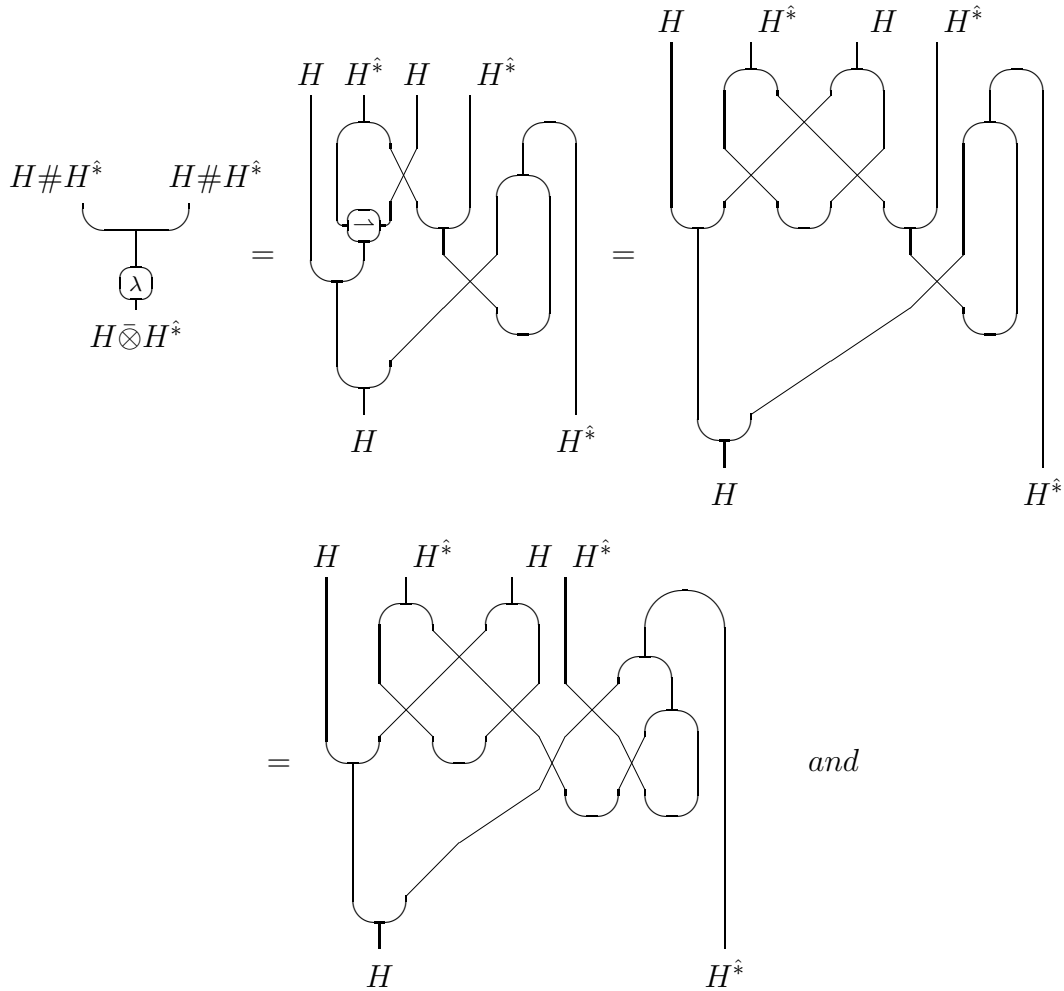

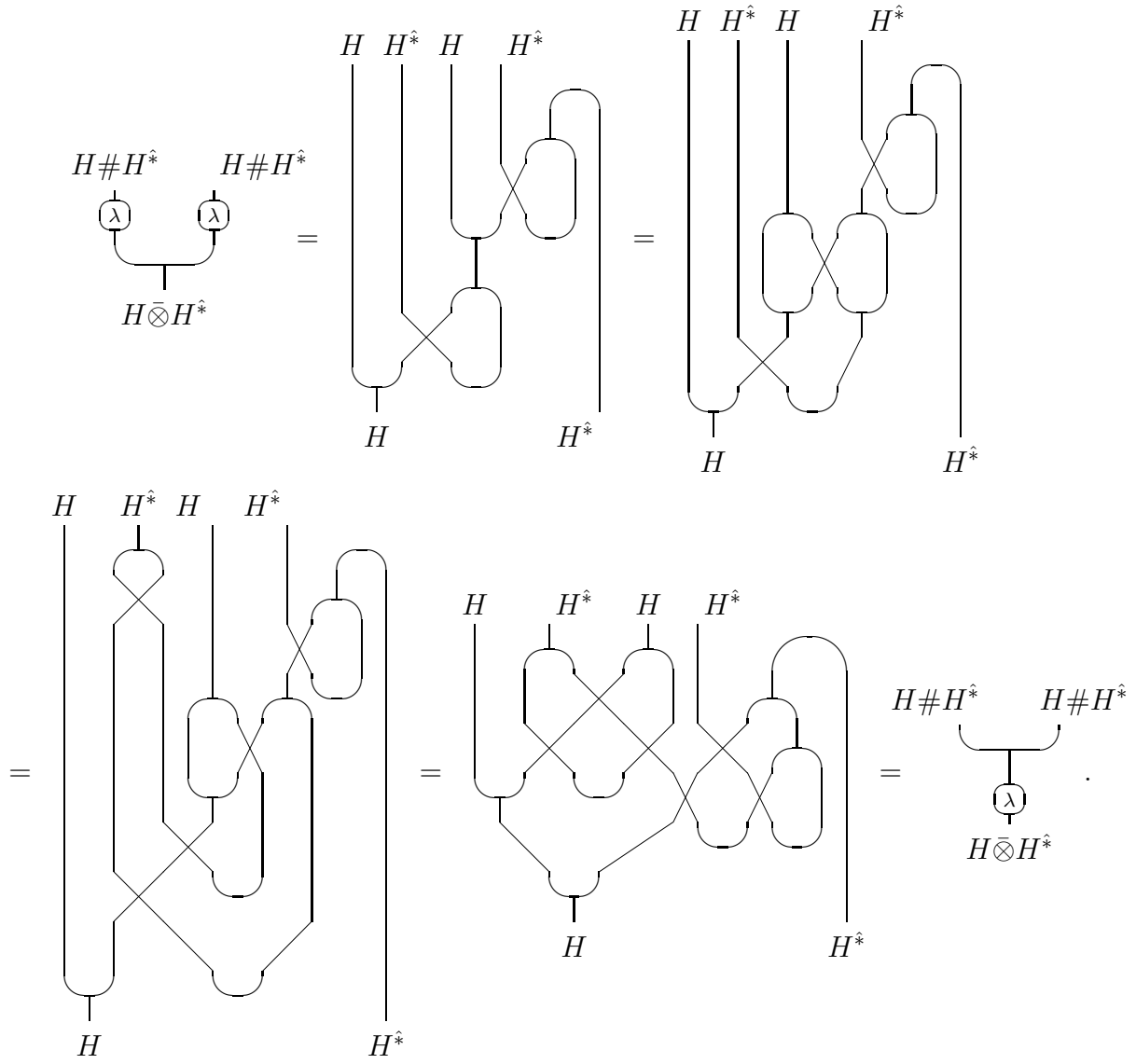

Thus λ is an algebraic morphism.

Similarly, we can show that ρ is an anti-algebraic morphism. \square

The proof of Theorem 2.5.

$$\begin{array}{c}
 H \quad H^{\hat{}} \quad H^{\hat{}} \quad H \\
 \vdots \\
 \text{[Complex Diagram with } S, \ominus, \rho, \lambda \text{]} \\
 \vdots \\
 H \otimes H^{\hat{}}
 \end{array}
 \quad \dots (1)$$

We show (1) by following five steps. It is easy to check the following (i) and (ii).

(i)

$$\begin{array}{c}
 H \# \eta_{H^{\hat{}}} \quad \eta_{H^{\hat{}}} \# H \\
 \vdots \\
 \text{[Diagram with } \lambda, \rho \text{]} \\
 \vdots \\
 H \otimes H^{\hat{}}
 \end{array}
 \quad = \quad
 \begin{array}{c}
 H \# \eta_{H^{\hat{}}} \quad \eta_{H^{\hat{}}} \# H \\
 \vdots \\
 \text{[Diagram with } \rho, \lambda \text{]} \\
 \vdots \\
 H \otimes H^{\hat{}}
 \end{array}$$

(ii)

$$\begin{array}{c}
 \eta_H \# H^{\hat{}} \quad H^{\hat{}} \# \eta_H \\
 \vdots \\
 \text{[Diagram with } \lambda, \rho \text{]} \\
 \vdots \\
 H \otimes H^{\hat{}}
 \end{array}
 \quad = \quad
 \begin{array}{c}
 \eta_H \# H^{\hat{}} \quad H^{\hat{}} \# \eta_H \\
 \vdots \\
 \text{[Diagram with } \rho, \lambda \text{]} \\
 \vdots \\
 H \otimes H^{\hat{}}
 \end{array}$$

(iii)

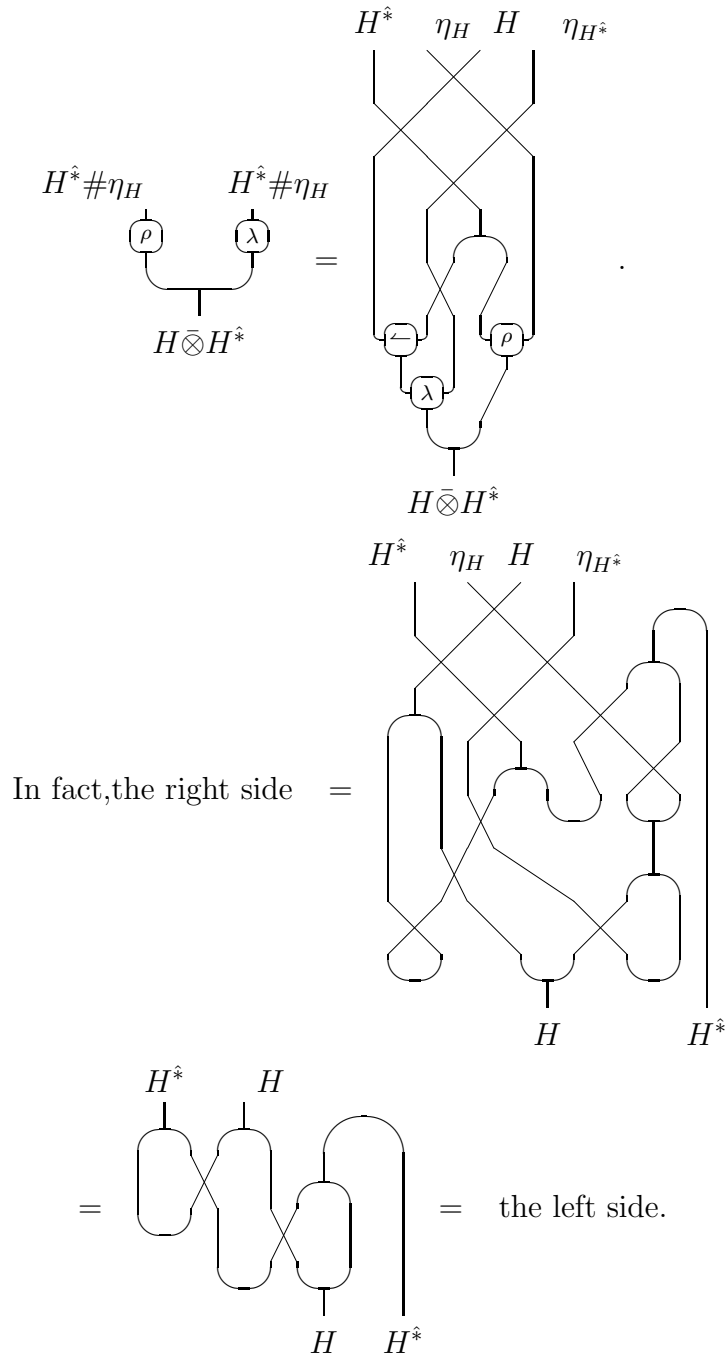

Thus (iii) holds.

(iv)

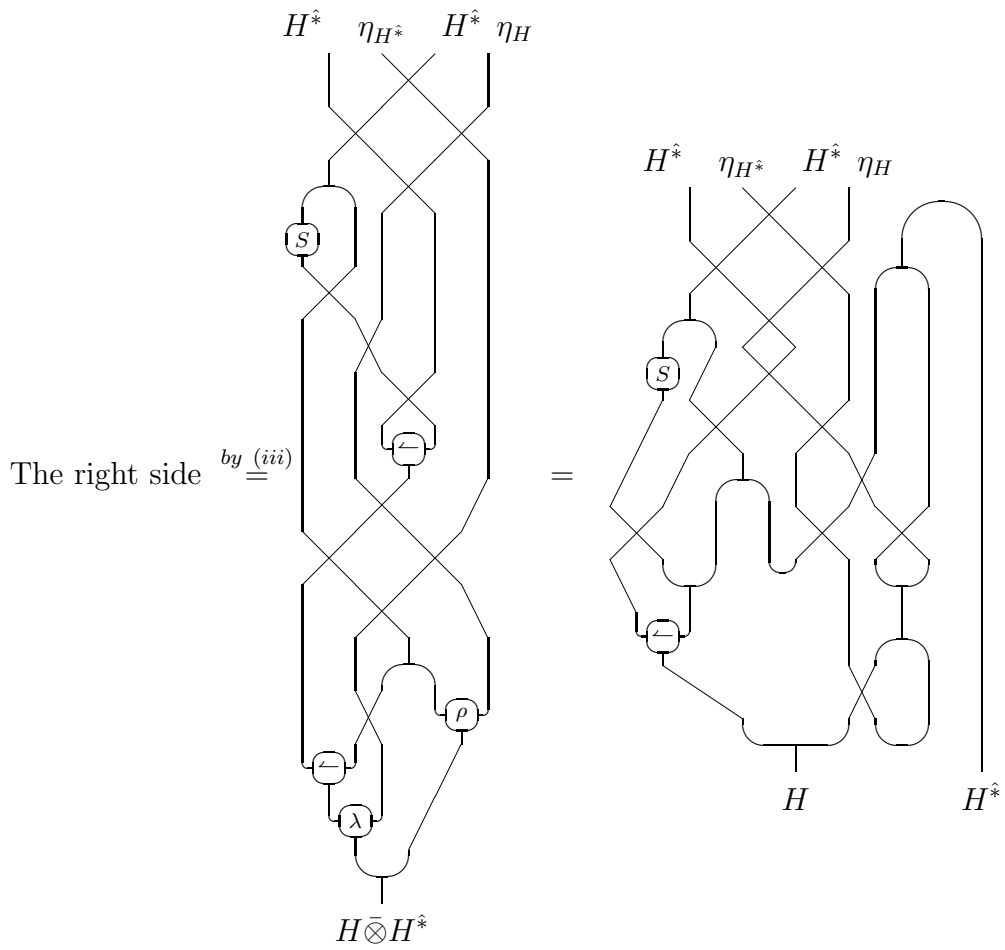
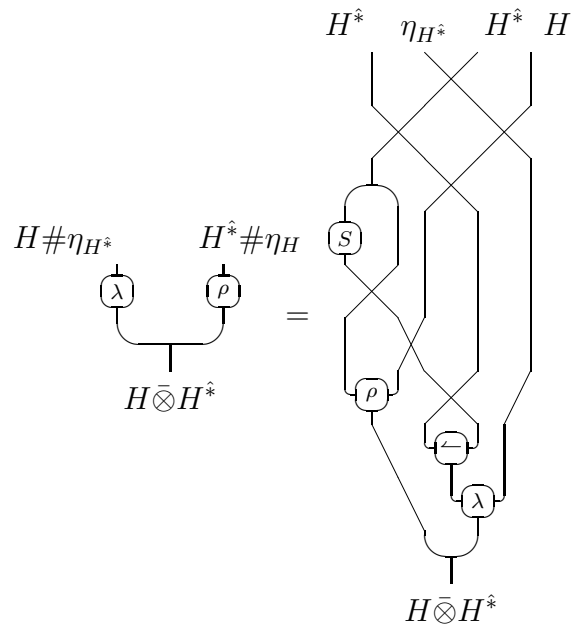

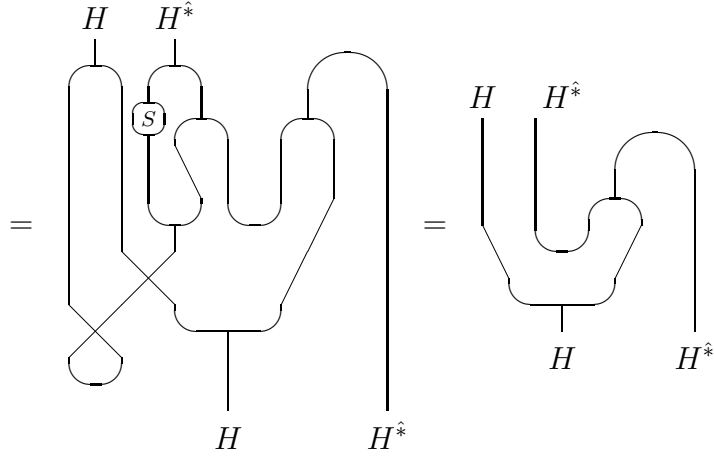

and

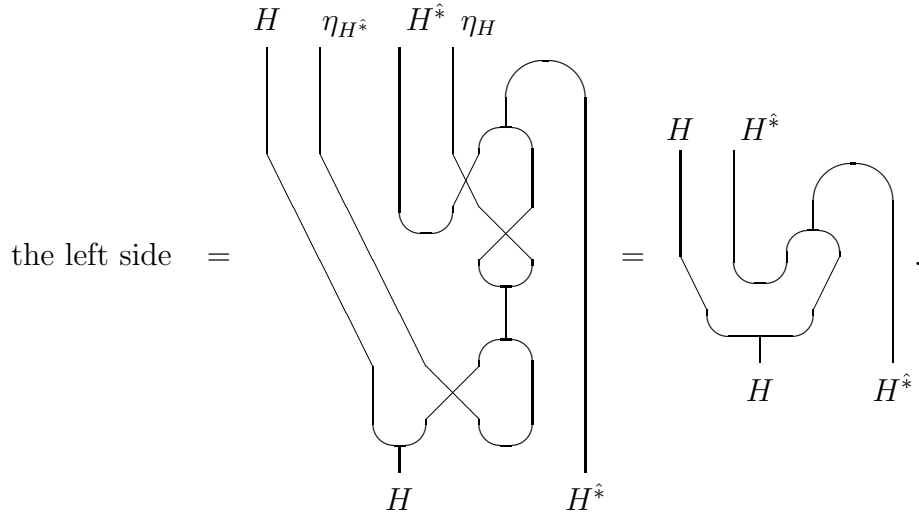

Thus (iv) holds.

(v)

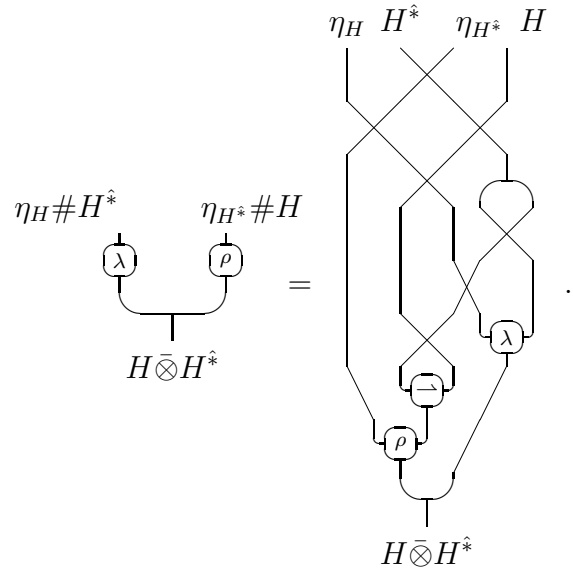

In fact, the right side =

$\eta_H \quad H^{\hat{*}} \quad \eta_{H^{\hat{*}}} \quad H$

$H^{\hat{*}} \quad H$

$H \quad H^{\hat{*}}$

and

the left side =

$H^{\hat{*}} \quad H$

$H \quad H^{\hat{*}}$

$H \quad H^{\hat{*}}$

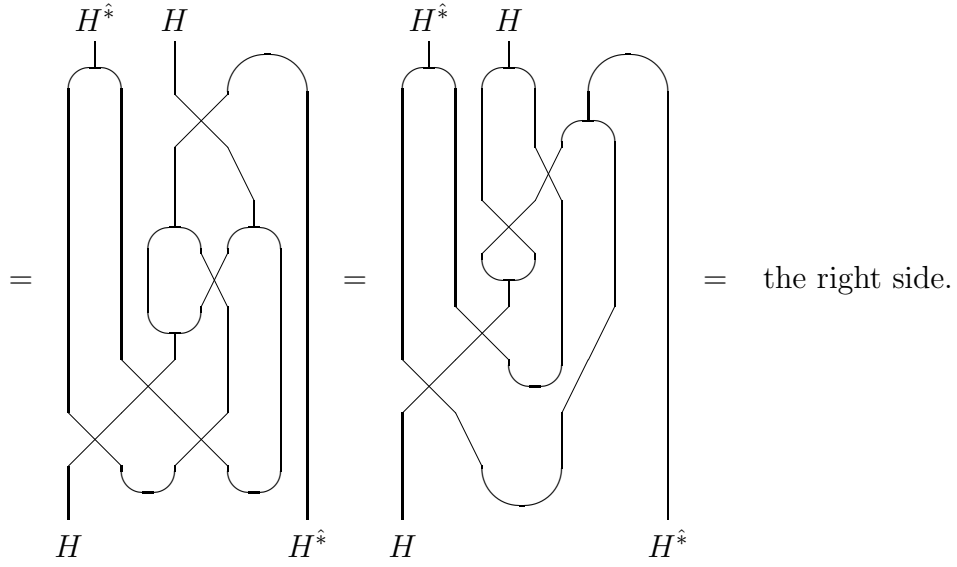

Thus (v) holds.

Now we show that the relation (1) holds.

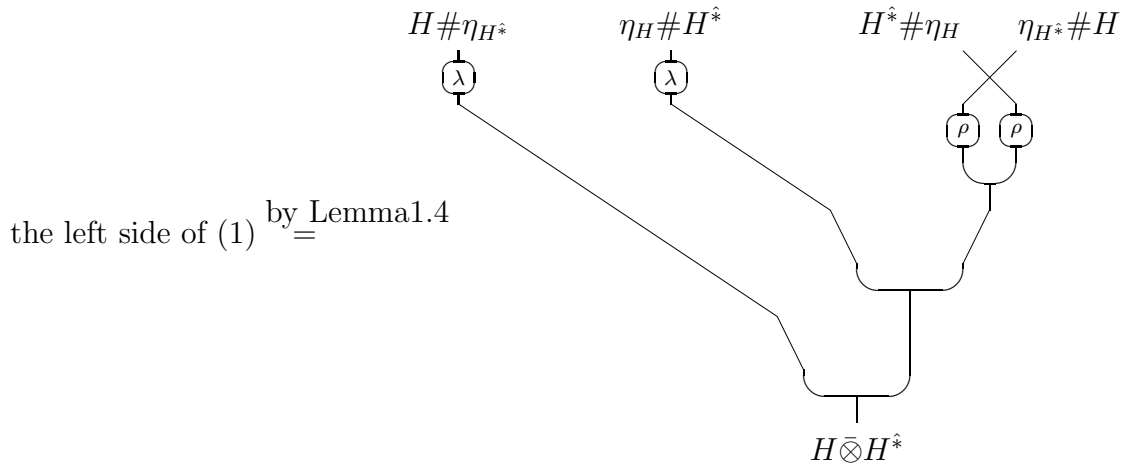

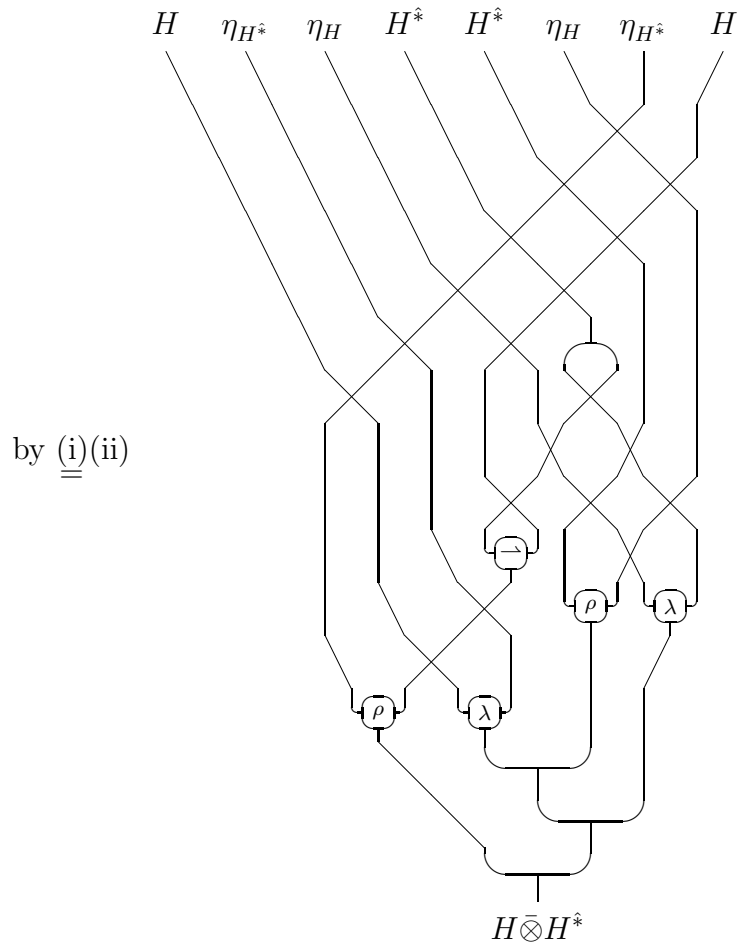
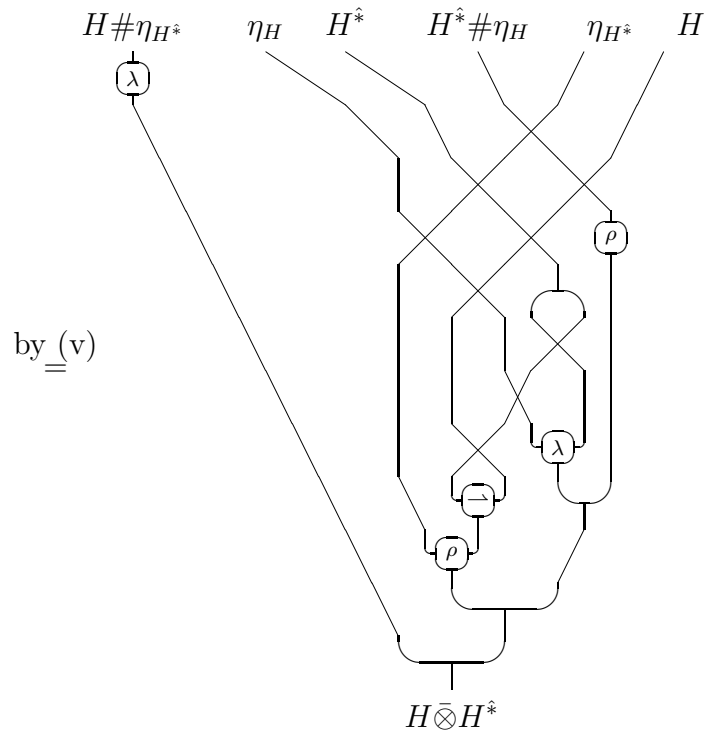

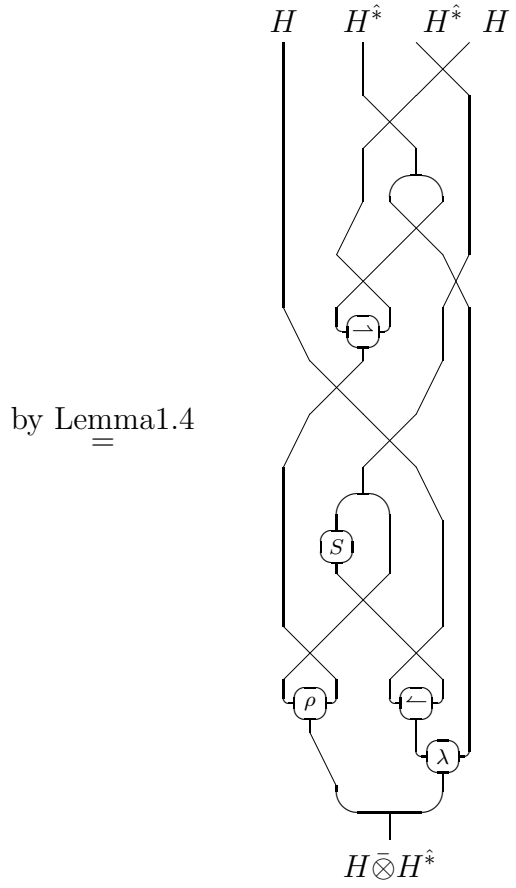
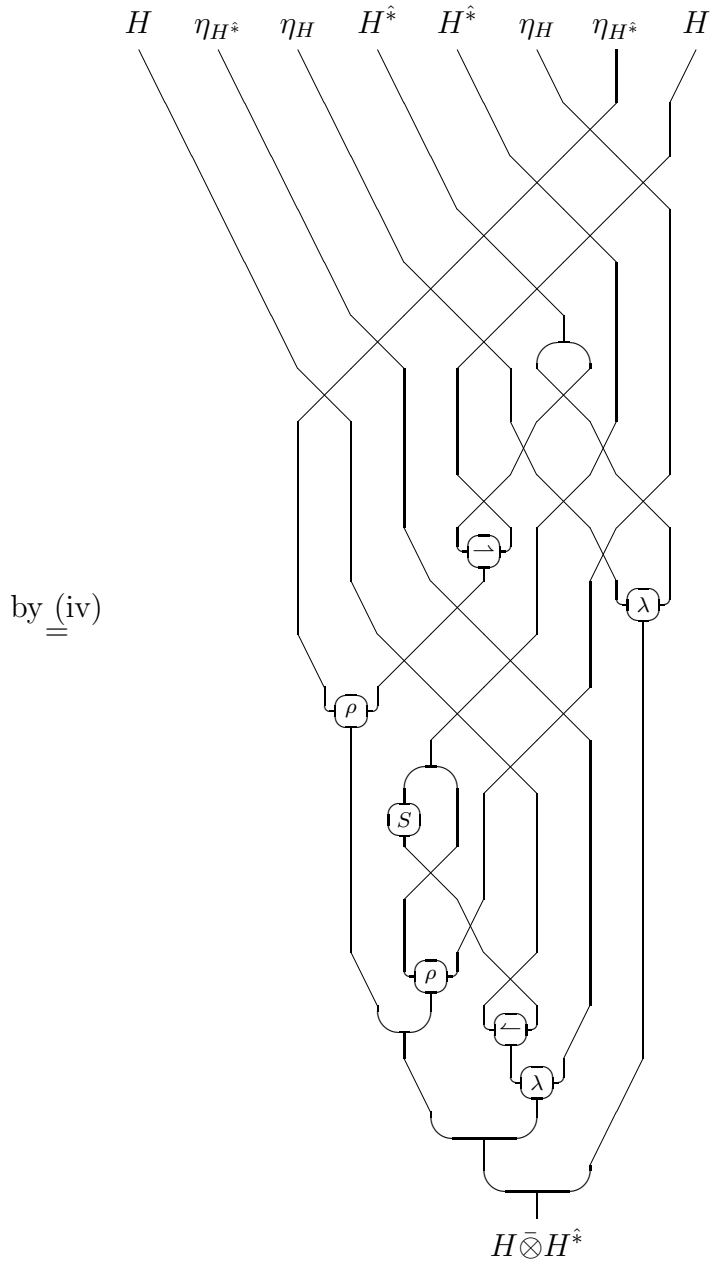

$H \quad H^{\hat{*}} \quad H^{\hat{*}} \quad H$
 $=$ $=$ the right side of (1). \square
 $H^{\hat{*}} \otimes H^{\hat{*}}$

The proof of Theorem 2.8 .

(i)

Let $\begin{array}{c} H^{\hat{*}} \\ | \\ \textcircled{w} \\ | \\ H \# H^{\hat{*}} \end{array} = \begin{array}{c} H^{\hat{*}} \\ | \\ \textcircled{S} \\ | \\ \textcircled{\rho} \\ | \\ \textcircled{\lambda^{-1}} \\ | \\ H \# H^{\hat{*}} \end{array}$ and $\begin{array}{c} R \\ | \\ \textcircled{\phi} \\ | \\ H^{\hat{*}} \quad R \end{array} = \begin{array}{c} R \\ | \\ \textcircled{b'} \\ | \\ \textcircled{\alpha} \\ | \\ H^{\hat{*}} \quad R \end{array} = \begin{array}{c} R \\ | \\ \textcircled{\alpha} \\ | \\ H^{\hat{*}} \quad R \end{array}$, where $b' = C_{H, H^{\hat{*}}} b_H$.

We define

$\begin{array}{c} R \otimes (H \# H^{\hat{*}}) \\ | \\ \textcircled{\Psi} \\ | \\ (R \# H) \# H^{\hat{*}} \end{array} = \begin{array}{c} R \quad H \quad H^{\hat{*}} \\ | \quad | \quad | \\ \textcircled{\phi} \\ | \\ \textcircled{S} \\ | \\ \textcircled{w} \\ | \\ \textcircled{\lambda^{-1}} \\ | \\ R \quad H \quad H^{\hat{*}} \end{array}$ and $\begin{array}{c} (R \# H) \# H^{\hat{*}} \\ | \\ \textcircled{\Phi} \\ | \\ R \otimes (H \# H^{\hat{*}}) \end{array} = \begin{array}{c} R \quad H \quad H^{\hat{*}} \\ | \quad | \quad | \\ \textcircled{\phi} \\ | \\ \textcircled{w} \\ | \\ \textcircled{\lambda^{-1}} \\ | \\ R \quad H \quad H^{\hat{*}} \end{array}$.

We see that

$$\begin{aligned}
 \Psi\Phi &= \text{Diagram 1} \quad \text{since } w \text{ is algebraic} \quad \text{Diagram 2} \\
 &= \text{Diagram 3} = \text{Diagram 4} = \text{Diagram 5}
 \end{aligned}$$

Similarly, we have $\Phi\Psi = id$. Thus Φ is invertible.

Now we show that Φ is algebraic.

$$\text{Let } \begin{array}{c} (R\#H)\#H^{\hat{*}} \\ \downarrow \\ \Phi' \\ \downarrow \\ R \otimes (H \bar{\otimes} H^{\hat{*}}) \end{array} = \text{Diagram 6}$$

It is clear that $\Phi = (id \otimes \lambda^{-1})\Phi'$. Consequently, we only need show that Φ' is algebraic.

Let

$$\begin{array}{c} R \\ | \\ \xi \\ | \\ R \otimes (H \bar{\otimes} H^{\hat{*}}) \end{array} = \begin{array}{c} \begin{array}{c} R \\ | \\ \eta_H \\ | \\ \rho \end{array} \\ \begin{array}{c} \begin{array}{c} \bar{S} \\ | \\ \alpha \end{array} \\ \begin{array}{c} b' \\ | \\ \alpha \end{array} \\ \begin{array}{c} R \\ | \\ \alpha \end{array} \end{array} \end{array} .$$

We have that

$$\begin{array}{c} (R \# H) \# H^{\hat{*}} \\ | \\ \Phi' \\ | \\ R \otimes (H \bar{\otimes} H^{\hat{*}}) \end{array} = \begin{array}{c} \begin{array}{c} R \\ | \\ \xi \end{array} \\ \begin{array}{c} H \# H^{\hat{*}} \\ | \\ \lambda \end{array} \end{array} .$$

We claim that

$$\begin{array}{c} \begin{array}{c} H \\ | \\ \lambda \end{array} \\ \begin{array}{c} H^{\hat{*}} \\ | \\ \xi \end{array} \\ \begin{array}{c} R \\ | \\ \xi \end{array} \\ | \\ R \otimes (H \bar{\otimes} H^{\hat{*}}) \end{array} = \begin{array}{c} \begin{array}{c} H \\ | \\ \xi \end{array} \\ \begin{array}{c} H^{\hat{*}} \\ | \\ \lambda \end{array} \\ \begin{array}{c} R \\ | \\ \lambda \end{array} \\ | \\ R \otimes (H \bar{\otimes} H^{\hat{*}}) \end{array} . \quad \dots (*)$$

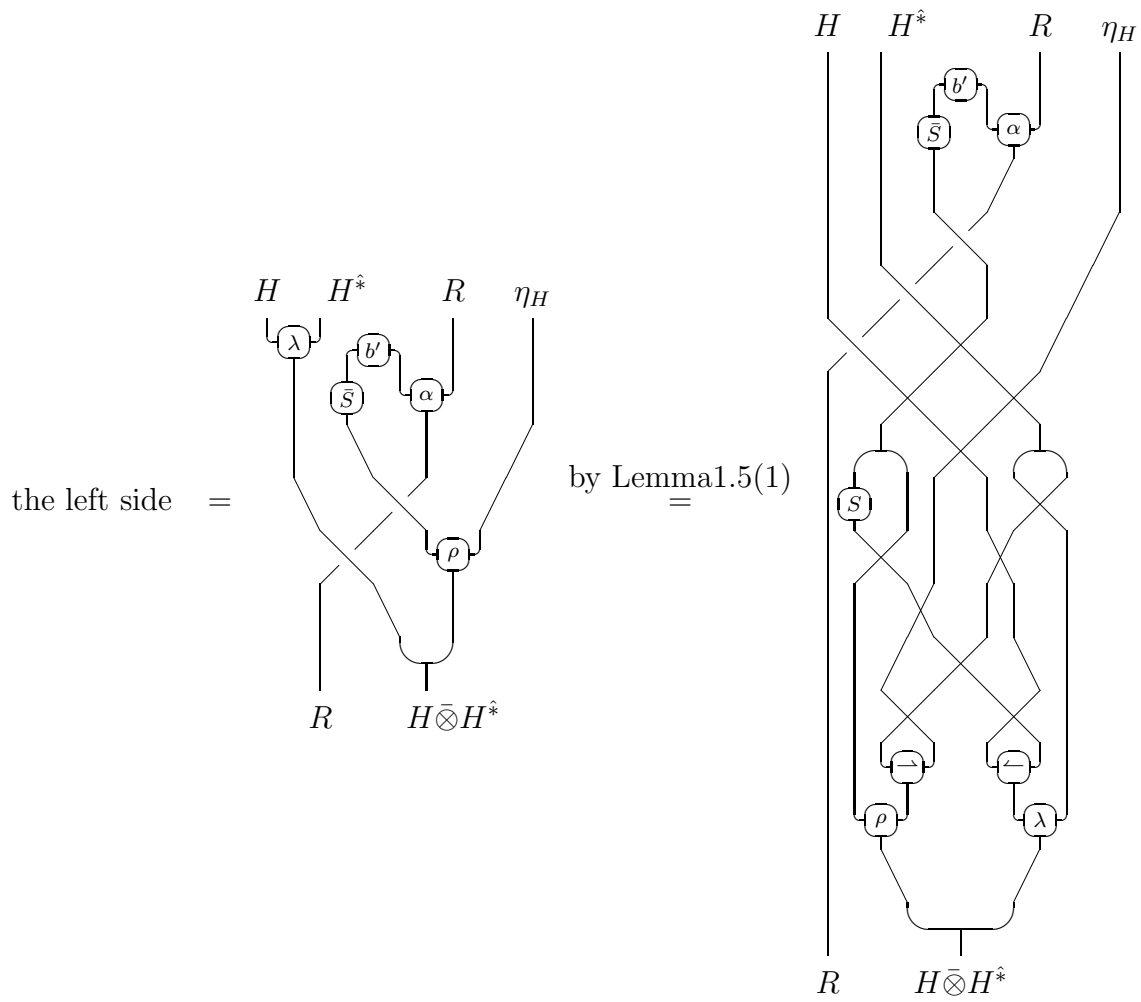

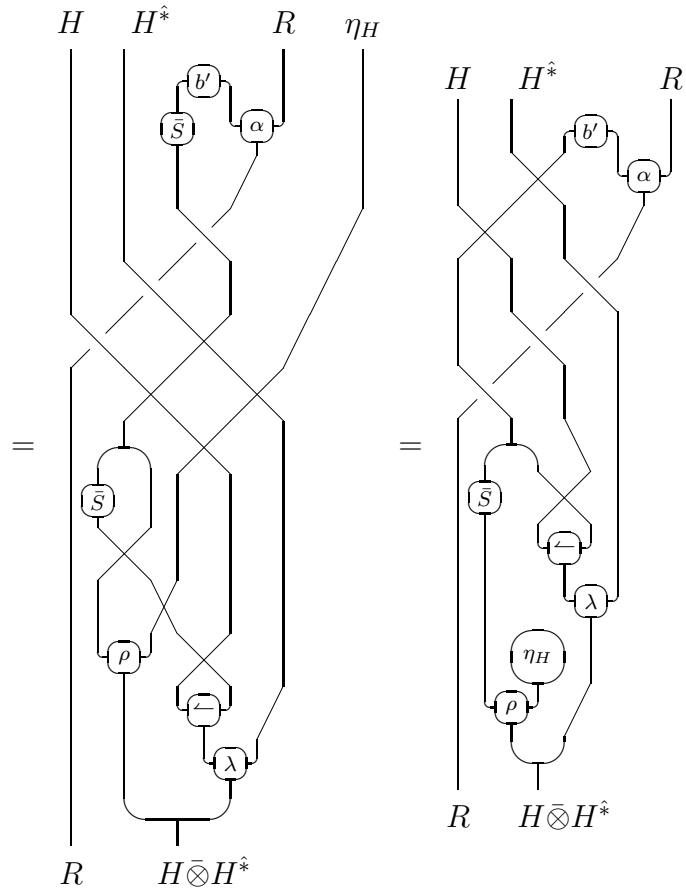

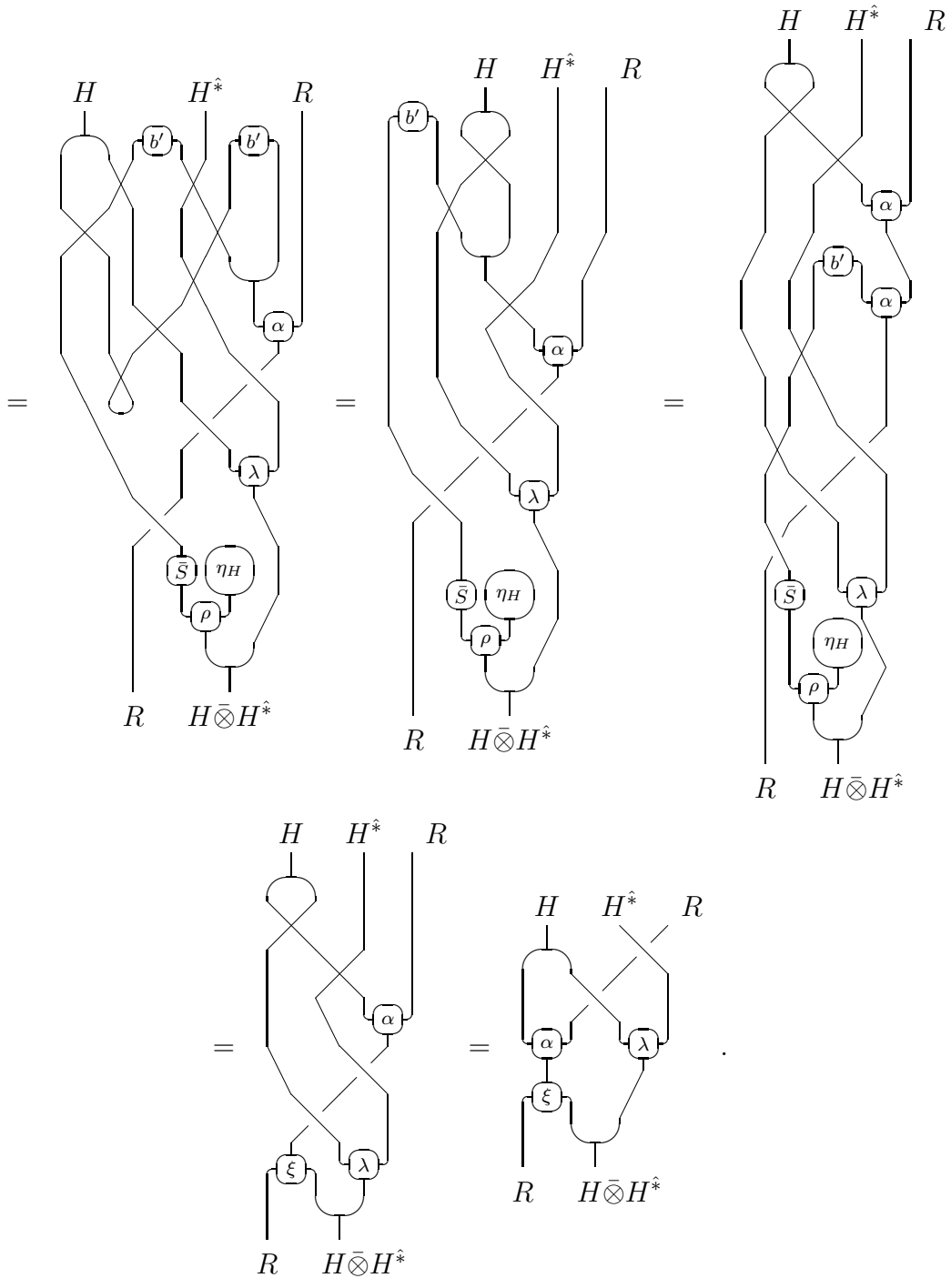

Thus relation (*) holds.

Next, we check that ξ is algebraic. We see that

$R \otimes (H \bar{\otimes} H^{\hat{*}})$

and obviously

$R \otimes (H \bar{\otimes} H^{\hat{*}})$

Thus ξ is algebraic.

Now we show that Φ' is algebraic.

$R \otimes (H \bar{\otimes} H^{\hat{*}})$

The proof of Lemma 3.2.

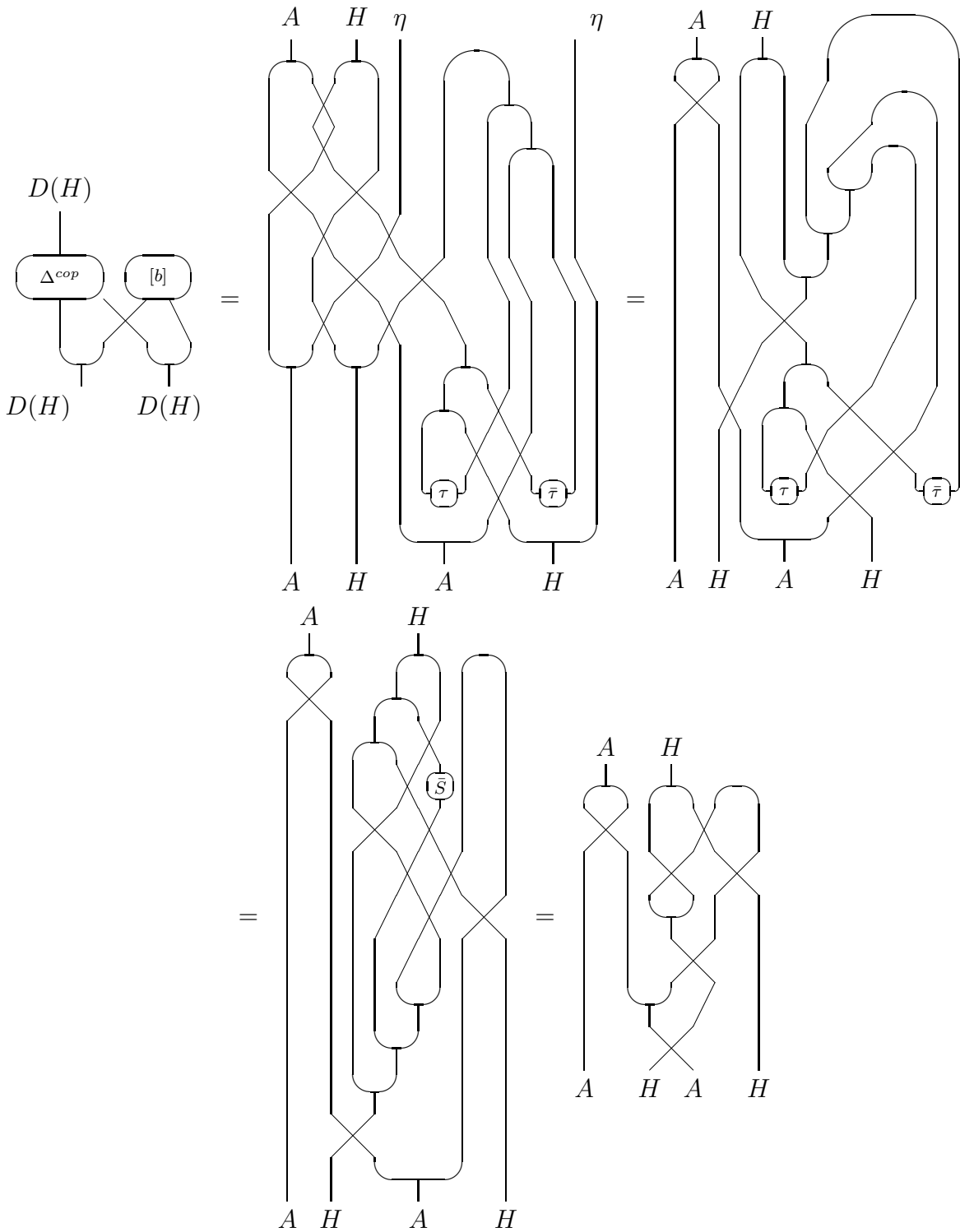

and

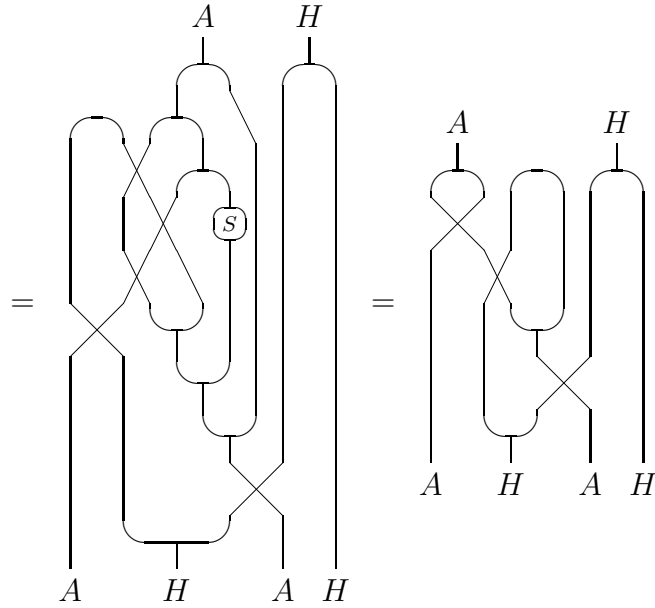
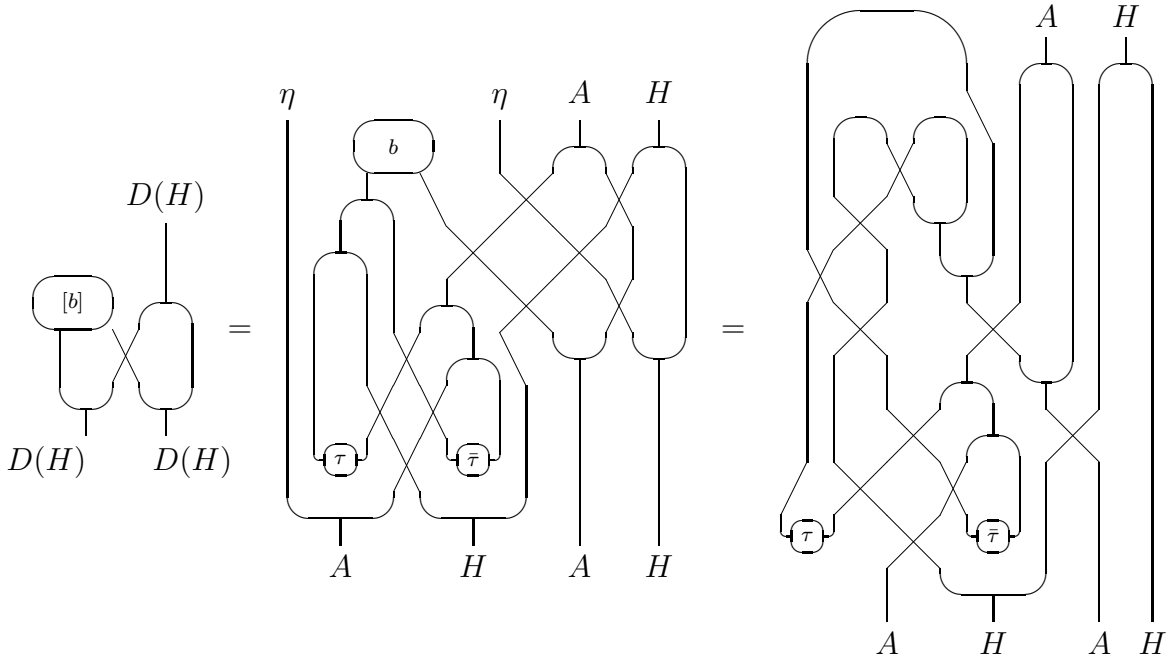

Thus

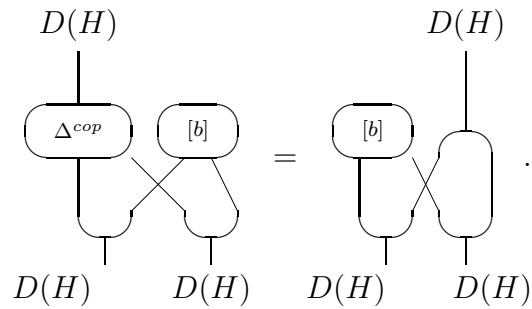

We complete the proof. \square

Remark: If U and V have left dual U^* and V^* , respectively, then $U^* \otimes V^*$ and $V^* \otimes U^*$ both are the left duals of $U \otimes V$. Their evaluations and coevaluations are

$$d_{U \otimes V} = (d_U \otimes d_V)(id_{U^*} \otimes C_{V^*,U} \otimes id_V), \quad b_{U \otimes V} = (id_U \otimes (C_{V,U^*})^{-1} \otimes id_{V^*})(b_U \otimes b_V);$$

$$d_{U \otimes V} = d_V(id_{V^*} \otimes d_U \otimes id_V), \quad b_{U \otimes V} = (id_{U^*} \otimes b_V \otimes id_U)b_U,$$

respectively. In this paper, we use the second. $H^{\hat{*}}$ is the left dual of H under the first.