

Strong Tunneling and Coulomb Blockade in a Single-Electron Transistor

D. Chouvaev¹, L.S. Kuzmin¹, D.S. Golubev^{1,3} and A.D. Zaikin^{2,3}

¹ Chalmers University of Technology, Fysikgränd 3, S-41296 Gothenburg, Sweden

² Institut für Theoretische Festkörperphysik, Universität Karlsruhe, 76128 Karlsruhe, Germany

³ I.E. Tamm Department of Theoretical Physics, P.N. Lebedev Physics Institute, Leninski pr. 53, 117924 Moscow, Russia

We have developed a detailed experimental study of a single-electron transistor in a strong tunneling regime. Although weakened by strong charge fluctuations, Coulomb effects were found to persist in all samples including one with the effective conductance 8 times higher than the quantum value $(6.45 \text{ k}\Omega)^{-1}$. A good agreement between our experimental data and theoretical results for the strong tunneling limit is found. A reliable operation of transistors with conductances 3-4 times larger than the quantum value is demonstrated.

Mesoscopic tunnel junctions between metals represent a nontrivial example of a macroscopic quantum system with discrete charge states and dissipation [1,2]. Charging effects in such systems can be conveniently studied in the so-called SET (single electron tunneling) transistors. A typical SET transistor consists of a central metallic island connected to the external leads via two tunnel junctions with resistances $R_{L,R}$ and capacitances $C_{L,R}$ (see Fig. 1). In addition to the transport voltage V , the gate voltage V_g can also be applied to the metallic island via the gate capacitance C_g .

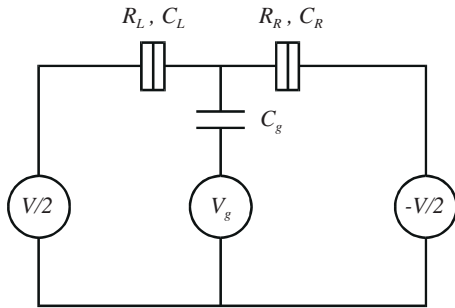

FIG. 1. Schematics of a SET transistor.

Provided the junction resistances are large $R_{L,R} \gg R_q = \pi\hbar/2e^2 \simeq 6.45 \text{ k}\Omega$ tunneling effects are weak and can be treated perturbatively [3]. For a quantitative measure of the tunneling strength we define the parameter $\alpha_t = R_q/R_0$, where $1/R_0 = 1/R_L + 1/R_R$. After each electron tunneling event the charge of a central island changes exactly by e and the energy difference between initial and final states of a SET device is typically of order $E_C = e^2/2C$, where $C = C_L + C_R + C_g$. As long as tunneling is weak $\alpha_t \ll 1$ dissipative broadening of different charge states Γ is small (at low T it is roughly $\Gamma \sim \alpha_t E_C$) and these states are well resolved in energy. This ensures nearly perfect quantization of the charge on a central island in units of e . As a result at sufficiently low $T \lesssim E_C$ Coulomb effects dominate the behavior of a SET transistor leading to a number of observable effects, such as Coulomb blockade of tunneling, modulation of the current through a SET transistor by a gate voltage

V_g , Coulomb staircase on the $I - V$ curve etc. [1].

The situation changes if the effective resistance R_0 becomes of order of R_q or smaller, i.e. $\alpha_t \gtrsim 1$. In this case dissipation is large and the excited charge states of the system become broadened and overlap. Do strong charge fluctuations lead to a complete smearing of Coulomb effects in highly conducting mesoscopic tunnel junctions?

A positive answer on this question was suggested in Refs. [4,5]. It was argued that – similarly to Ohmic resistors (see e.g. [2]) – charging effects should be *completely* destroyed in junctions with $\alpha_t \gtrsim 1$. According to [4,5] no Coulomb gap can exist for such values of α_t and a crossover to a purely Ohmic behavior was predicted.

Note that the above conclusion was obtained from studies of a certain correlation function which turned out to be irrelevant for the problem in question. In contrast, in Ref. [6] a nonperturbative analysis of the junction ground state energy has been developed. This analysis clearly demonstrates the existence of a nonvanishing Coulomb gap $E_C^* \propto E_C \exp(-2\alpha_t)$ in the spectrum of the system even for large $\alpha_t \gg 1$. Thus strong tunneling *does not* destroy Coulomb effects, it only leads to effective renormalization of the junction capacitance. As a result the temperature interval relevant for charging effects shrinks, but they still remain observable even at $T \gg E_C^*$.

This behavior is *qualitatively* different from that of an Ohmic resistor. The physical reason for this difference was also pointed out in [6]. It is due to different symmetries of the allowed charge states: the symmetry is continuous in the case of an Ohmic shunt, whereas only discrete e -periodic charge states are allowed in the case of a normal tunnel junction (see also Ref. [2]). The latter symmetry remains the same for any SET strength, and therefore at low T Coulomb effects survive and can be well observed even in highly conducting junctions. The results [6] were supported by subsequent theoretical studies (see e.g. [7] for a discussion and further references).

In spite of all these theoretical developments, an experimental investigation of this problem was lacking. Recently Joyez et al. [8] carried out an experiment aimed

to study strong tunneling effects in SET transistors with higher junction conductances. Deviations from the standard “orthodox” theory [1] were clearly detected in four different samples [8]. A very recent analysis [9,7] demonstrated that for three samples [8] with smaller α_t a remarkably good quantitative description of the data [8] is achieved already within the perturbation theory in α_t if one retains the “cotunneling” terms $\propto \alpha_t^2$. Hence, the above samples [8] are still well in the *perturbative* weak tunneling regime: the corresponding values of α_t are large enough to observe deviations from the “orthodox” theory, but still too small for nonperturbative effects to come into play (see below).

The main goal of the present paper is to develop a detailed experimental study of Coulomb effects in mesoscopic tunnel junctions in a *nonperturbative* strong tunneling regime $\alpha_t \gtrsim 1$. Beside its fundamental importance the problem is also of interest in view of possible applications of SET transistors as electrometers. The operating frequency range of such devices with $\alpha_t \ll 1$ is usually restricted to very low values. One possible way to increase such frequencies is to decrease the junction resistance, i.e. to fabricate SET transistors with $\alpha_t \gtrsim 1$. But do such SET transistors exhibit charging effects?

In this paper we investigate if Coulomb effects survive in the strong tunneling regime $\alpha_t \gtrsim 1$, in which case discrete charge states are essentially smeared due to dissipation. For this purpose we have carried out measurements of the current-voltage characteristics of several SET transistors with various values of the junction resistance $R_{L,R} \gtrsim R_q$ in the limit of a zero resistance of the external circuit. The results are compared with the existing theory [7,10].

Experiment. We have fabricated several SET transistors with different values of the junction resistance. The transistors were made using a standard electron-beam lithography with two-layer resist and two-angle shadow evaporation of aluminum. Five transistors with junction resistances in the range from 2 k Ω to 20 k Ω were studied. The corresponding values of α_t varied between 1.5 and 8.3. The crosssection area of the tunnel junctions is estimated to be $\sim 0.01 \mu\text{m}^2$.

Measurements were done in a dilution refrigerator capable to hold temperature from 20 mK to 1.2 K. Magnetic field of 2 Tesla was applied to keep aluminum in the normal state. Thermocoax[©] cables and a copper-powder filter next to the mixing chamber of the refrigerator provided necessary filtering against high frequency noise penetration.

We have measured the $I-V$ characteristics of the transistors at different temperatures and gate voltages. At low voltages our measurements were performed using a lock-in amplifier with 6 Hz reference signal frequency in the constant voltage mode (a feedback was used to control the amplitude of the excitation in order to keep the output signal at the same level).

Theory. At not very low temperatures (or voltages) the quantum dynamics of a tunnel junction is well described by the quasiclassical Langevin equation [11]

$$C_j \frac{\hbar \ddot{\varphi}_j}{e} + \frac{1}{R_j} \frac{\hbar \dot{\varphi}_j}{e} = J_j + \xi_{j1} \cos \varphi_j + \xi_{j2} \sin \varphi_j, \quad (1)$$

$j = L, R$; J_j is the current flowing through the junction; the phase variable φ_j is related to the voltage across the junction as $\hbar \dot{\varphi}_j / e = V_j$. Discrete electron tunneling is responsible for the noise terms in eqs. (1) described by the stochastic Gaussian variables $\xi_{jk}(t)$ with correlators

$$\langle \xi_{jk}(0) \xi_{j'k'}(t) \rangle = \delta_{jj'} \delta_{kk'} \frac{\hbar}{R_j} \int \frac{d\omega}{2\pi} e^{i\omega t} \omega \coth \left(\frac{\hbar\omega}{2T} \right) \quad (2)$$

The eqs. (1) are supplemented by the appropriate current balance and Kirghoff equations and can be solved perturbatively in the noise terms (see [7,10] for details). One arrives at the $I-V$ curve for a SET transistor [7]:

$$I(V) = \frac{V}{R_\Sigma} - I_0(V) - \frac{V}{R_\Sigma} A e^{-F} \cos \left(\frac{2\pi Q_{\text{av}}(V)}{e} \right); \quad (3)$$

where $Q_{\text{av}}(V) = C_g V_g + \frac{R_L C_L - R_R C_R}{R_L + R_R} V$ is the average charge of the island and $R_\Sigma = R_L + R_R$. The last two terms in eq. (3) describe deviations from the Ohmic behavior due to charging effects. In the case $R_L = R_R$ for the V_g -independent term $I_0(V)$ we find [7]

$$I_0(V) = \frac{V}{8R_q} [\text{Re}\Psi(b) - \text{Re}\Psi(a)] - \frac{E_C}{\pi e R_0} \text{Im}\Psi(b), \quad (4)$$

$\Psi(x)$ is the digamma function, $a = 1 - ieV/4\pi T$ and $b = a + 2\alpha_t E_C / \pi^2 T$. The expression (4) holds for [7]

$$\max\{eV, T\} \gg w_0 = \begin{cases} \frac{2\alpha_t}{\pi^2} e^{-2\alpha_t + \gamma} E_C, & \alpha_t \gtrsim 1 \\ E_C, & \alpha_t \lesssim 1 \end{cases} \quad (5)$$

$\gamma = 0.577..$ is the Euler constant. The last term in eq. (3) describes the modulation of the $I-V$ curve by the gate voltage. Provided the island charge fluctuations are large the amplitude of the modulation is exponentially suppressed [7,10]: $F(T, V) \gg 1$. The general expression for the function $F(T, V)$ [7] is quite complicated and is not presented here. In the limit of small voltages and for $T \ll \alpha_t E_C$ this expression becomes simpler, and we get

$$F(T, 0) \simeq (T/T_0)^2, \quad T_0 = \sqrt{12\alpha_t} E_C / \pi^2. \quad (6)$$

As the condition (5) should be simultaneously satisfied eq. (6) makes sense only for $\alpha_t \gtrsim 1$. The constant A in eq. (3) has the form [7,10] $A = f(\alpha_t) e^{-2\alpha_t}$. The prefactor $f(\alpha_t)$ was also estimated in [7,10] with a limited accuracy. More accurate results for $f(\alpha_t)$ at low T can be derived by means of other techniques [6].

Results and Discussion. In what follows we will disregard a small asymmetry in the parameters of L - and

R -junctions and put $R_0 = R_\Sigma/4$. The value of R_Σ was measured from the slope of the $I - V$ curve at high voltages. The accuracy of these measurements was limited by nonlinearities on the $I - V$ curves due to suppression of tunnel barriers and heating and is estimated as $\sim 3\%$. The charging energy E_C is usually determined from the offset on the $I - V$ curve at large V . In the strong tunneling regime $\alpha_t \gtrsim 1$ a clear offset can be reached only at very high voltages where precise measurements are difficult due to other reasons. Therefore, the above method gives only a rough estimate of E_C with the accuracy within a factor 2. Alternatively one can try to determine E_C from the high temperature expansion of a zero-bias conductance: $G(T) = (1/R_\Sigma)(1 - E_C/3T + \dots)$. For our samples this asymptotics works well only at $T \gtrsim 10$ K and could not be reached in the same cooling cycle. Therefore, the parameter E_C was determined from the best fit of the low-temperature (≤ 1 K) and low-voltage ($\leq 700\mu\text{eV}$) parts of the $I - V$ curves averaged over the gate charge. Fitting of dI/dV for different temperatures allows to determine E_C with a sufficiently high accuracy and avoid problems discussed above. Also the precise value of α_t can be verified by this method.

The results are summarized in the following table:

TABLE I. Parameters of the samples

Sample	R_Σ , k Ω	α_t	E_c , K	$10w_0$, μeV	$10w_0$, mK
I	17.4	1.48	2.25	50	600
II	12	2.15	1.1	10	100
III	10.4	2.48	1.04	5	60
IV	6.5	3.97	1.16	0.5	6
V	3.1	8.32	~ 0.3	5×10^{-4}	5×10^{-3}

The last two columns show the lowest voltage and temperature $\sim 10w_0$ where the theory is still applicable.

The data for a temperature dependent zero bias conductance averaged over the gate charge are given in Fig. 2 for four samples (filled symbols) together with the theoretical dependencies $G_{\text{av}}^{\text{theor}} = 1/R_\Sigma - I_0/V|_{V=0}$ (solid curves). The Coulomb blockade induced suppression of the conductance at low T is clearly seen even for a highly conducting sample IV. We observe a good agreement between theory and experiment except at the lowest temperatures where the theoretical results become unreliable. In this temperature interval the theoretical curves turn out to be closer to the minimum conductance which is also shown by open symbols. At low T the system conductance shows a tendency to saturation. This is compatible with the corresponding conjecture made in Ref. [7]. On the other hand, heating effects as an additional reason for this saturation cannot be excluded either.

The averaged differential conductance dI/dV is shown in the bottom panel of the Fig. 3 for all five samples at the lowest temperature $T \approx 20$ mK. It is remarkable that even for the sample V with $\alpha_t > 8$ a decrease of

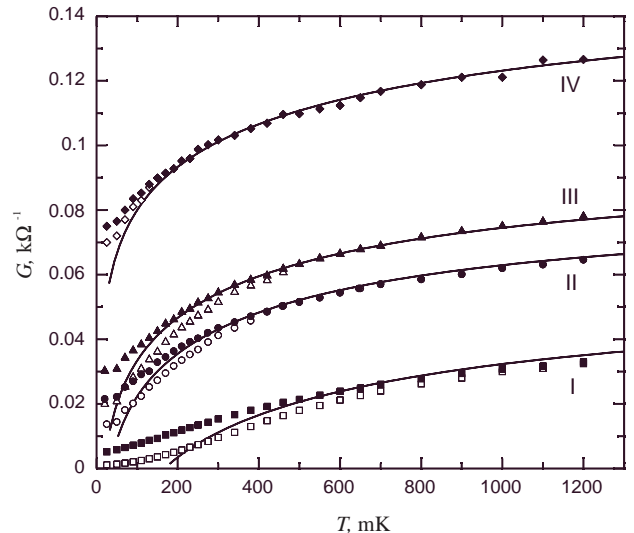

FIG. 2. The averaged over V_g (filled symbols) and the minimum (open symbols) values for the linear conductance of the samples I-IV together with a theoretical prediction for the averaged conductance (solid curves).

the differential conductance at small V due to charging effects is well pronounced. The values dI/dV measured for the sample II for different temperatures are presented in the top panel together with a theoretical prediction from eq. (4). A similarly good agreement between theory and experiment was also found for the samples III, IV, and V.

The gate modulation of the current was found to be of a simple cosine form (3) for all samples except for a relatively highly resistive sample I at low T . The results for the gate modulated linear conductance of the sample II are shown in Fig. 4a. The amplitude of modulation increases with decreasing temperature in a qualitative agreement with theory. At low T the modulation effect is considerable even for the sample IV with $\alpha_t \simeq 4$. At the lowest temperatures this effect is visible also for the sample V. However in this case the amplitude of modulation was only slightly above the average noise level.

The data for the temperature dependent amplitude of conductance modulation for the samples I-IV are presented in Fig. 4b. Solid curves correspond to the best fit with a theoretical dependence $\propto \exp(-T^2/T_0^2)$ (cf. eqs. (3, 6)). Note, that for all samples the best fit value T_0 was found to be by a numerical factor $\sim 2 \div 3$ smaller than the value (6). In other words, the temperature suppression of the gate modulation is *bigger* than it is predicted theoretically. We speculate that this may be due to an additional effect of noise. Another possible reason for such a discrepancy is an insufficient accuracy of the theoretical calculations of the gate modulated conductance.

Our experimental results clearly show that – in accordance with earlier theoretical predictions – Coulomb blockade is *not* destroyed even in the strong tunneling regime: clear signs of Coulomb suppression of the transis-

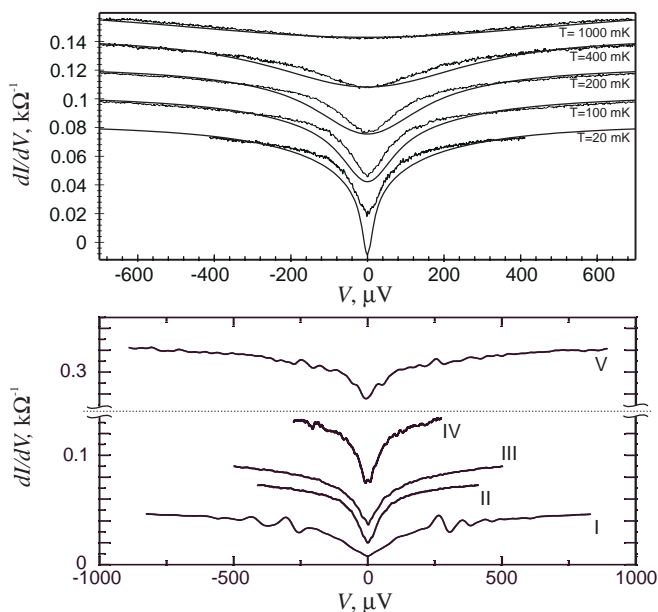

FIG. 3. The V_g -averaged differential conductance. Top panel: the data for the sample II (thinner curves) together with theoretical results (thicker curves). For the sake of clarity the curves at higher T are shifted vertically with a step $0.02 \text{ k}\Omega^{-1}$. Bottom panel: the data for all five samples at $T \simeq 20 \text{ mK}$.

tor conductance were observed for α_t as large as 8.3. For all α_t the characteristic energy scale for charging effects is set by the renormalized Coulomb gap E_C^* , however such effects remain well pronounced even at $T \gg E_C^*$. The $I - V$ curves measured for all five SET transistors are in a quantitative agreement with the strong tunneling theory [7,10], except at very low temperatures where this theory is not applicable. Along with the overall suppression of the conductance its modulation by the gate voltage was also observed at sufficiently low T . The modulation effect increases with decreasing temperature in a qualitative agreement with theoretical predictions.

Our work was aimed to study SET transistors in the nonperturbative strong tunneling regime. In this sense our experiment is complementary to that by Joyez et al. [8] where SET transistors with smaller α_t were studied. Theoretically, a perturbative regime characterized by an expansion parameter $g = \alpha_t/\pi^2 \ll 1$ (see e.g. [3,7,9]) can be easily distinguished from a strong tunneling one with $\exp(-2\alpha_t) \ll 1$ (cf. e.g. [6,7]) except within the interval $0.5 \lesssim \alpha_t \lesssim 3$ where both inequalities are (roughly) satisfied. Combining our results with those of Ref. [8] as well as with the corresponding theoretical predictions [7,9,10] we can draw a more definitive conclusion about the validity range for both regimes: tunneling can be treated perturbatively for $\alpha_t \lesssim 1$ while the nonperturbative tunneling regime sets in for $\alpha_t \gtrsim 2$. In the intermediate $1 \lesssim \alpha_t \lesssim 2$ nonperturbative results can be also applied at temperatures not much lower than E_C .

In summary, we have demonstrated that SET transis-

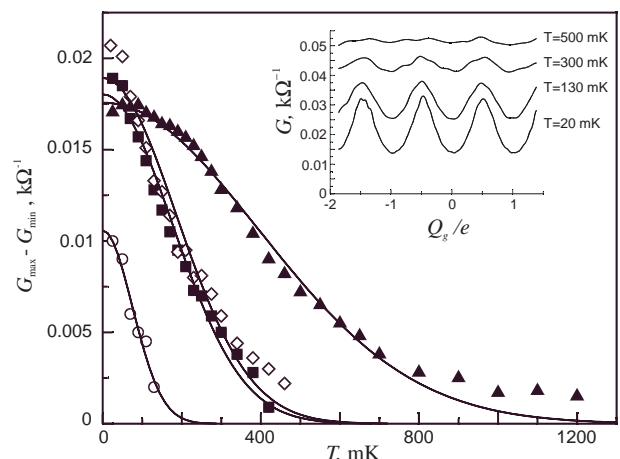

FIG. 4. The gate modulation amplitude $G_{\max} - G_{\min}$ of a linear conductance as a function of T for the samples I-IV (triangles, squares, diamonds and circles respectively). Solid lines provide the best fit with a formula $A \exp(-(T/T_0)^2)$. The inset: the linear conductance of the sample II as a function of $Q_g = C_g V_g$ measured at different T .

tors operate well even if the effective tunneling resistance R_0 is *several times smaller* than $6.5 \text{ k}\Omega$.

The work was supported by the Deutsche Forschungsgemeinschaft within SFB 195, by the INTAS-RFBR Grant 95-1305, by the Swedish NFR and by SI. The samples were fabricated at the Swedish Nanometer Laboratory.

-
- [1] D.V. Averin and K.K Likharev, in *Mesoscopic Phenomena in Solids*, ed. by B.L. Altshuler, P.A. Lee and R.A. Webb, eds., p. 173 (Elsevier, Amsterdam, 1991).
 - [2] G. Schön and A.D. Zaikin, Phys. Rep. **198**, 237 (1990).
 - [3] In this regime nonperturbative effects become important only in the vicinity of the Coulomb blockade threshold, see K.A. Matveev, Zh. Eksp. Teor. Fiz. **99**, 1598 (1991) [Sov. Phys. JETP **72**, 892 (1991)]; D.S. Golubev and A.D. Zaikin, Phys. Rev. B **50**, 8736 (1994); H. Schoeller and G. Schön, Phys. Rev. B **50**, 18436 (1994).
 - [4] W. Zwerger and M. Scharpf, Z. Phys. **85**, 421 (1991).
 - [5] R. Brown and E. Simanek, Phys. Rev. B **45**, 6069 (1992).
 - [6] S.V. Panyukov and A.D. Zaikin, Phys. Rev. Lett. **67**, 3168 (1991).
 - [7] D.S. Golubev, J. König, H. Schoeller, G. Schön and A.D. Zaikin, Phys. Rev. B **56**, 15782 (1997).
 - [8] P. Joyez, V. Bouchiat, D. Estève, C. Urbina and M.H. Devoret, Phys. Rev. Lett. **79**, 1349 (1997).
 - [9] J. König, H. Schoeller, and G. Schön, Phys. Rev. Lett. **78**, 4482 (1997).
 - [10] D.S. Golubev and A.D. Zaikin, Zh. Eksp. Teor. Fiz. Pis'ma Red. **63**, 953 (1996) [JETP Lett. **63**, 1007 (1996)].
 - [11] U. Eckern, G. Schön and V. Ambegaokar, Phys. Rev B **30**, 6419, (1984); D.S. Golubev and A.D. Zaikin, Phys. Rev. B **46**, 10903 (1992).