

Coulomb blockade of tunneling through a double quantum dot

K. A. Matveev,⁽¹⁾ L. I. Glazman,⁽²⁾ and H. U. Baranger⁽³⁾

⁽¹⁾*Massachusetts Institute of Technology, 12-105, Cambridge MA 02139*

⁽²⁾*Theoretical Physics Institute, University of Minnesota, Minneapolis MN 55455*

⁽³⁾*AT&T Bell Laboratories, 600 Mountain Ave. 1D-230, Murray Hill NJ 07974-0636*

(Submitted to Phys. Rev. B, 8 December 1995)

We study the Coulomb blockade of tunneling through a double quantum dot. The temperature dependence of the linear conductance is strongly affected by the inter-dot tunneling. As the tunneling grows, a crossover from temperature-independent peak conductance to a power-law suppression of conductance at low temperatures is predicted. This suppression is a manifestation of the Anderson orthogonality catastrophe associated with the charge re-distribution between the dots, which accompanies the tunneling of an electron into a dot. We find analytically the shapes of the Coulomb blockade peaks in conductance as a function of gate voltage.

PACS numbers: 73.20.Dx, 73.40.Gk

I. INTRODUCTION

Electron tunneling in a mesoscopic structure may be significantly affected by the charging effects. The charging suppresses tunneling, if the charge spreading is impeded by weak links, or by a special geometry of the structure. Such a suppression of tunneling is commonly referred to as the Coulomb blockade, for a review see Ref. 1. In recent experiments² it has become possible to observe the Coulomb blockade in semiconductor heterostructures where the geometry of the system can be easily modified by adjusting the voltages on special gate electrodes.

A common example of the Coulomb blockade effect is a measurement of linear conductance between two macroscopic leads weakly coupled to a quantum dot.² When an electron tunnels from a lead to the dot, the electrostatic energy of the system

$$U = \frac{e^2 n^2}{2C} - \kappa e n V_g \quad (1)$$

changes; here C is the capacitance of the dot, en is its charge, V_g is the gate voltage, and $\kappa = C_g/C$ is a dimensionless geometrical factor which defines the gate capacitance C_g . At low temperatures, $T \ll e^2/2C$, the equilibrium discrete charge of the system is determined by the minimum of U . Tunneling of an electron into or out of the dot leads to a large increase of the energy, and conduction through the dot is suppressed. However, at certain values of the gate voltage the electrostatic energy is degenerate,

$$U(n) = U(n+1), \quad (2)$$

and the Coulomb blockade is lifted. Therefore, the linear conductance shows a series of peaks at the gate voltages $V_g^* = (2n+1)e/2C_g$. The heights and shapes of the peaks can be found³ using the master equation technique,

$$G = \frac{G_l G_r}{2(G_l + G_r)} \frac{\kappa e (V_g - V_g^*)/T}{\sinh[\kappa e (V_g - V_g^*)/T]}. \quad (3)$$

Here $G_{l,r}$ are the conductances of the weak links connecting the dot to the leads.

In a number of recent experimental⁴⁻⁸ and theoretical^{5,9-13} papers tunneling through two coupled quantum dots was explored. In particular, by using a double dot structure one can probe the quantum charge fluctuations more directly than in a single dot.^{4,5,12} Here we focus on the geometry of Ref. 4 shown schematically in Fig. 1, in which the dependence of the peak positions on the conductance G_0 of the constriction between the two dots was studied. We discuss the theory of the peak positions in Sec. II. As G_0 grows and approaches $2e^2/h$, the peaks become equidistant, and in this respect the two-dot system behaves as a single dot of a larger size. It is clear, however, that unlike a large single dot, the charge spreading between the two coupled dots is impeded, and takes a relatively long time, $t \sim C/G_0 \sim \hbar(e^2/C)^{-1}$. The characteristic energy related to this time delay, \hbar/t , is of the order of the charging energy, and one can expect it to affect the conductance through the double-dot system and cause deviations from Eq. (3). Indeed, in Sec. III we show that the slow propagation of charge between the dots results in a suppression of the conductance peaks. The specific shape and temperature dependence of a conductance peak provides one with information about quantum fluctuations of charge between the two dots.

II. POSITIONS OF THE PEAKS IN LINEAR CONDUCTANCE

To discuss the Coulomb blockade, one has to introduce the electrostatic energy of the system shown in Fig. 1. In the experiment⁴ the potentials of the dots were controlled by a single gate voltage V_g . Clearly, the equilibrium electrostatic energy is a function of three variables: the discrete charges of the two dots eN_1 and eN_2 , and the gate voltage V_g . It also depends on the capacitances of

the dots—to the gate, to the external world, and to each other—which introduce five parameters into the problem. We will use the following expression for the electrostatic energy

$$U(N_1, N_2) = E_C(N_1 + N_2 - 2X)^2 + \tilde{E}_C[N_1 - N_2 + \lambda(N_1 + N_2) - \alpha X]^2, \quad (4)$$

where X is a dimensionless variable proportional to V_g . The effective circuit we have in mind, the exact relation between X and V_g , and expressions for the parameters E_C , \tilde{E}_C , λ and α in terms of the capacitances of the dots can be found in Appendix A.

We intentionally grouped the terms in Eq. (4) in such a way that the energy depends on the total number of particles in the two dots $N_1 + N_2$ and the relative charge $N_1 - N_2$. In this paper we assume that the coupling of the double-dot system to the leads is extremely weak, $G_l, G_r \ll G_0$, and therefore one can neglect the quantum fluctuations of $N_1 + N_2$. On the other hand, the inter-dot conductance G_0 is not necessarily small, and at $G_0 \sim e^2/h$ the fluctuations of $N_1 - N_2$ are significant. The tunneling of the electron between the dots lowers the ground state energy of the system. Thus to determine the positions of the peaks in the linear conductance one should generalize Eq. (2) by replacing the electrostatic energy U with the ground state energy of the double-dot system $E_{\mathcal{N}}(X)$ for a fixed total number of electrons $\mathcal{N} = N_1 + N_2$. That is, the peak positions X^* are given by

$$E_{\mathcal{N}}(X^*) = E_{\mathcal{N}+1}(X^*). \quad (5)$$

Early attempts at the calculation of the peak positions were based on models allowing only a few discrete states in each dot.^{10,11} Such an approach should provide an adequate description of the system in the case of extremely small quantum dots. In typical experiments,⁴⁻⁸ however, the number of states in each dot is large, and a model with continuous spectra of electrons is more appropriate. The calculation of the ground-state energy for such a model in the limits of weak and strong coupling between the dots can be found using the techniques developed in Refs. 14,15. For a symmetric system, $\lambda = \alpha = 0$, in the weak tunneling case, $G_0 \ll e^2/h$, the peaks are centered at the following values of the gate voltage:^{12,13}

$$X_{\pm}^* = n + \frac{1}{2} \pm \frac{1}{4} \left[1 - \frac{\tilde{E}_C}{E_C} \left(1 - \frac{2 \ln 2}{\pi^2} \frac{hG_0}{e^2} \right) \right], \quad (6)$$

where n is any integer. The peak splitting $X_+ - X_-$ grows linearly with G_0 .

In agreement with the experiment,⁴ for a symmetric system, $\alpha = \lambda = 0$, the peaks at small conductance G_0 are doubly degenerate (assuming $\tilde{E}_C = E_C$, which is a good approximation for the experiment⁴). Even a small asymmetry, $\alpha \ll 1$, lifts this degeneracy. Indeed, the positions of the peaks as $G_0 \rightarrow 0$ can be found from (5)

with the electrostatic energy (4) as the full energy. As a result we find the two sequences of peaks

$$X_1^* = \frac{n + 1/2}{1 + \alpha/2}, \quad X_2^* = \frac{n + 1/2}{1 - \alpha/2}, \quad (7)$$

where again n is any integer. An asymmetry of the system caused by a non-zero λ in Eq. (4) also leads to the lifting of the degeneracy.

One can easily see that the peak positions given by Eq. (7) show periodic beats: near certain values of the gate voltage X the neighboring peaks come very close together—they are separated by a distance of order α —while between those values of X the peaks are separated by $\delta X \sim 1$. The period of these beats is α^{-1} . In the regions where the distance between the neighboring peaks predicted by Eq. (7) is small, an additional splitting due to the quantum charge fluctuations caused by finite inter-dot conductance G_0 should be taken into account. This additional peak splitting can be found in the same way as the splitting (6) in the symmetric case. For the case $\tilde{E}_C = E_C$, the result is $\delta X = (\ln 2/\pi^2)hG_0/e^2$.

In the opposite case of strong coupling the properties of the system depend on the particular model of the junction between the dots. For an electrostatically created constriction between the dots, a one-dimensional (1D) model of the junction is the most appropriate.¹⁶ In this case the conductance G_0 never exceeds $2e^2/h$, and the strong-tunneling case corresponds to a small reflection coefficient $\mathcal{R} = 1 - hG_0/2e^2 \ll 1$. We will concentrate on the asymmetric case, $\alpha > 0$, assuming for simplicity $\lambda = 0$, and derive the peak positions X^* from Eq. (5). At fixed $\mathcal{N} = N_1 + N_2$ the electrostatic energy (4) can be rewritten as

$$U_{\mathcal{N}}(N_1) = E_C(\mathcal{N} - 2X)^2 + 4\tilde{E}_C(N_1 - \gamma)^2, \quad (8)$$

where $\gamma = (\mathcal{N} + \alpha X)/2$. The second term on the right-hand side is expressed in terms of the number of particles in the left dot. In the strong tunneling case N_1 is no longer quantized, and at $\mathcal{R} \rightarrow 1$ its average assumes the value $\langle N_1 \rangle = \gamma$, thus minimizing the electrostatic energy. In this limit one easily finds $E_{\mathcal{N}}(X) = E_C(\mathcal{N} - 2X)^2$, and the peaks are equidistant, $X^* = (2n + 1)/4$.

At non-zero \mathcal{R} the average number of particles in the left dot $\langle N_1 \rangle$ is not precisely equal to γ , but oscillates near γ with period $\Delta\gamma = 1$. The corresponding small periodic contribution to the ground state energy was found in Ref. 15, where a single quantum dot connected to a large lead was considered. At temperatures exceeding the level spacings in both dots the two problems are equivalent, and one can use the result¹⁵ for the periodic correction to the ground state energy,

$$E_{\mathcal{N}}(X) = E_C(\mathcal{N} - 2X)^2 - \frac{16e^C}{\pi^3} \mathcal{R} \tilde{E}_C \ln \left[\frac{1}{\mathcal{R} \cos^2 \phi(\gamma)} \right] \cos^2 \phi(\gamma). \quad (9)$$

where $\mathbf{C} = 0.5772\dots$ is Euler's constant, and $\phi(\gamma)$ is defined as $\phi(\gamma) = \phi_0 + \pi\gamma$. In contrast to Ref. 15, we included here a shift ϕ_0 in the phase $\phi(\gamma)$ of the Coulomb blockade oscillations. Such a phase shift is always present, for instance, due to an asymmetry of the scattering potential in the constriction connecting the dots. In the case of a single dot connected to a large lead¹⁵ the presence of ϕ_0 is irrelevant, as it can always be compensated by an appropriate shift of the gate voltage. Similarly, in the case of a double-dot system the phase ϕ_0 can be incorporated in the definition of X as some shift [see the definition of γ in Eq. (8)], unless the system is completely symmetric, $\alpha = 0$.

One can now use the expression for the ground state energy (9) to find the corrections to the equidistant peak positions caused by the weak scattering in the constriction. From Eq. (5) we find

$$X^* = \frac{2n+1}{4} + (-1)^n \frac{4e^{\mathbf{C}} \tilde{E}_C}{\pi^3 E_C} \mathcal{R} \ln \frac{1}{\mathcal{R}} \cos(2\phi_0 + \pi\alpha X). \quad (10)$$

This result for the peak positions in the strong tunneling regime, $\mathcal{R} \ll 1$, is a generalization of the results in Refs. 12,13 to the case of an asymmetric system. The asymmetry gives rise to the cosine factor in Eq. (10). Similarly to the regime of weak tunneling, in the asymmetric case the distance between the peaks shows beats, with the period in X being α^{-1} .

As we mentioned, the presence of even a weak asymmetry of the system destroys the periodicity of the peak positions and thus complicates the comparison of the experimentally observed peak splitting with the theory.^{12,13} One should note, however, that in both weak and strong tunneling cases, in the regions of the gate voltage X where the peak splitting assumes the smallest possible values, the distance between the neighboring peaks coincides with that predicted by the theory^{12,13} for the symmetric case.

In the next section we calculate the heights and shapes of the conductance peaks, whose positions are given by Eqs. (6), (7), and (10), and compare the results with the available experiments.

III. HEIGHTS AND SHAPES OF THE CONDUCTANCE PEAKS

A. Weak tunneling between the dots

We start our discussion of the heights and shapes of the conductance peaks with the case of weak tunneling between the dots, which means that the conductance of the constriction is small, $G_0 \ll e^2/h$. Nevertheless, we assume that the coupling to the leads is even weaker, $G_l, G_r \ll G_0$. The results for the conductance depend on the symmetry of the system. In the symmetric case,

one can find the conductance within the master-equation approach, identical to the one used in a single-dot case.³ The resulting conductance has the form:

$$G = \frac{G_l G_r}{G_l + G_r} \frac{1}{2 + e^{-\beta(X-X_-^*)} + e^{-\beta(X_+^*-X)}} \times \left[\frac{\beta(X-X_-^*)}{e^{\beta(X-X_-^*)} - 1} + \frac{\beta(X_+^*-X)}{e^{\beta(X_+^*-X)} - 1} \right], \quad (11)$$

where $\beta = 4E_C/T$, and X_{\pm}^* are the positions of the two adjacent peaks given by Eq. (6) with the same n . The two peaks are resolved only at sufficiently low temperatures, $T \ll E_C(X_+^* - X_-^*)$ as shown explicitly in Fig. 2. The derivation of Eq. (11) is outlined in Appendix B.

In a symmetric device each state with an odd charge \mathcal{N} is doubly degenerate: the ‘‘odd’’ electron may be on either the left or right dot. In addition, at special values of gate voltage $X = X_{\pm}^*$, states with charges \mathcal{N} and $\mathcal{N}+1$ are degenerate. At these values of X , a charge can be transferred through the double-dot system via a sequence of real states. As a result, the peak conductance is temperature-independent.

A small asymmetry changes the situation qualitatively. As we saw in Sec. II, the presence of a non-zero α or λ in the electrostatic energy (4) lifts the degeneracy; i.e., the states with an ‘‘odd’’ electron on either the left or right dot now have different energies. If this difference of energies is larger than the temperature, one can no longer transfer charge through the double-dot system via real states only. For instance, at the value of the gate voltage $X_1^* = 1/(2 + \alpha)$ the energies of the states with charge 0 and with extra charge e on the left dot are equal, whereas the energy of the state with charge e on the right dot is $\Delta = 4\alpha E_C/(2 + \alpha)$. (Here we assume that all the asymmetry is due to $\alpha > 0$, and $\lambda = 0$, $\tilde{E}_C = E_C$.) At low temperatures the tunneling of an electron from the left dot to the right one involves an increase of the energy of the system by $\Delta > T$, and so tunneling through the double-dot system is suppressed. Nevertheless, an electron can still escape from the left dot to the right lead via a virtual state in the right dot. Such a mechanism of tunneling in Coulomb blockade devices is known as *cotunneling*.¹ At temperatures exceeding the level spacing in the dot, the leading mechanism is inelastic cotunneling.^{17,18} In this case an electron tunnels from the left dot to the right one, and then another electron tunnels from the right dot to the right lead. After the cotunneling process is completed, the right dot is returned to the state with no extra charge, but an electron-hole pair is created. As a result the phase space volume for such processes is proportional to T^2 , i.e., the conductance of the system is now suppressed at low temperatures.

Let us find the height and shape of a conductance peak at low temperatures, $T \ll \Delta$, for the example described. We first calculate the rate of cotunneling of an electron from the left dot to the right lead:

$$\frac{1}{\tau} = \frac{2\pi}{\hbar} \sum_{kpqs} \left| \frac{t_{pk}t_{sq}}{\Delta} \right|^2 n_k(1-n_p)n_q(1-n_s) \times \delta(\epsilon_k - \epsilon_p + \epsilon_q - \epsilon_s + \varepsilon), \quad (12)$$

where $t_{pk}t_{sq}/\Delta$ is the second-order matrix element for the transfer of an electron from state k in the left dot to state p in the right dot, and then the transfer of another electron from state q in the right dot to state s in the right lead; $n_{k(p,q,s)}$ and $\epsilon_{k(p,q,s)}$ are the corresponding Fermi occupation numbers and energies, respectively. We also defined

$$\varepsilon = U(1, 0) - U(0, 0) = 2(2 - \alpha)E_C(X_1^* - X). \quad (13)$$

A straightforward calculation now yields

$$\frac{1}{\tau(\varepsilon)} = \frac{\pi\hbar}{3e^4} G_0 G_r \left(\frac{T}{\Delta} \right)^2 \frac{\varepsilon[1 + (\varepsilon/2\pi T)^2]}{1 - e^{-\varepsilon/T}}. \quad (14)$$

Here we used the definition of the conductance $G_0 = (2\pi e^2/\hbar) \sum |t_{pk}|^2 \delta(\epsilon_k) \delta(\epsilon_p)$, and a similar relation for G_r .

One can now express the current through the system as

$$I = e \left[\frac{w_1}{\tau(\varepsilon)} - \frac{w_0}{\tau(-\varepsilon)} \right], \quad (15)$$

where w_0 and w_1 are the occupation probabilities of states with the charge of the left dot 0 and e , respectively. Since the escape rate to the right electrode is strongly suppressed and is much smaller than the rate of tunneling to the left lead, the left dot is in equilibrium with the left lead and

$$w_0 = \frac{1}{1 + e^{(\varepsilon - eV)/T}}, \quad w_1 = 1 - w_0. \quad (16)$$

Here V is the bias applied to the leads. An expansion of the current (15) to linear order in V gives the conductance

$$G = \frac{\pi\hbar}{6e^2} G_0 G_r \left(\frac{T}{\Delta} \right)^2 \frac{(\varepsilon/T)[1 + (\varepsilon/2\pi T)^2]}{\sinh(\varepsilon/T)}. \quad (17)$$

The dependence $\varepsilon(X)$ is given by Eq. (13).

As expected the height of the peak is suppressed at low temperatures as T^2 . The result (17) can be applied to any of the peaks (7) in the asymmetric system, provided that the appropriate values of Δ and ε are found from the electrostatic energy (4). The cotunneling peaks calculated for realistic parameters⁴ are presented in Fig. 3.

B. The limit of strong tunneling between the dots

In section III A we assumed that the coupling of the two dots is weak. This enabled us to apply the standard master equation technique in the case of a symmetric system, and to account for the lowest-order cotunneling process only in an asymmetric double-dot device. In this section we consider the limit of strong tunneling, where the techniques based on a simple perturbation theory are not applicable. We define the strong-tunneling limit as the case of perfect transmission through the channel between the dots, i.e., $G_0 = 2e^2/h$. To treat this limit, we apply here a non-perturbative approach based on the bosonized picture of the 1D transport through the channel.^{19,15,20}

We shall treat the double dot system as a single conductor of complicated shape. To find the conductance we will generalize the master-equation technique of Ref. 3 to account for the impedance of the charge propagation between the dots due to the narrow constriction. We need to find the renormalization of the rates of tunneling from the leads into the double-dot conductor. The impedance of the charge redistribution within this conductor suppresses the tunneling rates, not unlike the effect²¹ of the “electromagnetic environment” on transport through a single tunnel junction.

To find the rate of tunneling through, e.g., the left tunnel junction, we introduce a Hamiltonian that accounts for electron states in the left lead and left dot, as well as for the electron states participating in the re-distribution of the charge between the dots. The separation of the latter group of states from the two others is possible at time scales shorter than the time of electron propagation from the tunnel junction to the other dot. In the case of a single mode constriction, this time is of the order of the inverse level spacing in the dot. Therefore our theory is limited to temperatures exceeding the level spacing.

We assume that the constriction connecting the two dots is a single-mode channel with no reflection. In this case the set of electronic states responsible for the transport between the dots is one-dimensional and can be presented in a bosonized form.^{19,15} Thus the Hamiltonian can be written as $H = H_0 + H_C + H_t$,

$$H_0 = \sum_k \epsilon_k a_k^\dagger a_k + \sum_p \epsilon_p a_p^\dagger a_p + \sum_\sigma \int_{-\infty}^{\infty} \left[\frac{p_\sigma^2}{2mn_0} + \frac{mn_0 v_F^2}{2} \left(\frac{\partial u_\sigma}{\partial x} \right)^2 \right] dx, \quad (18)$$

$$H_C = E_C(n_L - 2X)^2 + 4\tilde{E}_C \left\{ n_0[u_\uparrow(0) + u_\downarrow(0)] - \frac{1+\lambda}{2}n_L + \frac{\alpha}{2}X \right\}^2, \quad (19)$$

$$H_t = \sum_{kp} \left(t_{kp} a_k^\dagger a_p F + t_{kp}^* a_p^\dagger a_k F^\dagger \right). \quad (20)$$

First, in H_0 , since we are considering transport of an electron from the left lead into the left-hand dot, a_k is the annihilation operator for electrons in the left lead and a_p is the operator for electrons in the left dot; ϵ_k and ϵ_p are the corresponding energies. The bosonized 1D electron system is described by the displacements $u_\sigma(x)$ and momentum densities $p_\sigma(x)$ in two spin channels, which satisfy the commutation relation $[u_\sigma(x), p_{\sigma'}(y)] = i\hbar\delta(x-y)\delta_{\sigma\sigma'}$; m and n_0 are the mass and density of 1D electrons. Second, in H_C , the charging energy (4) is written in terms of the operator n_L of the number of electrons tunneled through the left barrier and the charge $en_0[u_\uparrow(0) + u_\downarrow(0)]$ transferred from the left dot to the right one. Finally, in the tunnel Hamiltonian (20) the matrix elements t_{kp} describe tunneling through the barrier. The transfer of each electron into the dot changes n_L by one; to account for this, we use the operator F

defined by the commutation relation

$$[F, n_L] = F. \quad (21)$$

The tunneling current through the junction is

$$I_L \equiv e\langle \dot{n}_L \rangle = -\frac{ie}{\hbar}\langle [n_L, H_t] \rangle = \frac{2e}{\hbar}\text{Im} \sum_{kp} t_{kp}^* \langle a_p^\dagger a_k F^\dagger \rangle, \quad (22)$$

where the average is performed with the density matrix of the system described by the Hamiltonian (18)–(20). Assuming that the transmission coefficient of the tunnel barrier is small, we will calculate the tunneling current in lowest (second) order perturbation theory in t_{kp} . Thus we can expand the density matrix up to the first order in t_{kp} and find

$$I_L = -\frac{2e}{\hbar}\text{Re} \sum_{kp} |t_{kp}|^2 \int_{-\infty}^0 dt \left[\langle a_p^\dagger(0) a_p(t) \rangle \langle a_k(0) a_k^\dagger(t) \rangle \langle F^\dagger(0) F(t) \rangle - \langle a_k^\dagger(t) a_k(0) \rangle \langle a_p(t) a_p^\dagger(0) \rangle \langle F(t) F^\dagger(0) \rangle \right]. \quad (23)$$

In thermodynamic equilibrium the two contributions in I_L compensate each other. To find the effective conductance G_L of the left junction, which is renormalized due to the slow charge redistribution between the dots, we now shift the chemical potential in the lead by eV and find $G_L = dI_L/dV$ in the following form:²⁰

$$G_L = -\frac{i\pi}{\hbar^2} G_l T^2 \int_{-\infty}^{\infty} \frac{tK(t)dt}{\sinh^2[\pi T(t-i\delta)/\hbar]}. \quad (24)$$

Here $G_l = (2\pi e^2/\hbar) \sum |t_{kp}|^2 \delta(\epsilon_k) \delta(\epsilon_p)$ is the unrenormalized conductance of the left barrier, and we have introduced the correlator

$$K(t) = \langle F(t) F^\dagger(0) \rangle. \quad (25)$$

In the derivation of Eq. (24) we used the equality $\langle F(t) F^\dagger(0) \rangle = \langle F^\dagger(t) F(0) \rangle$, which follows from the symmetry of the Hamiltonian (18)–(20) with respect to the transformation $n_L \rightarrow -n_L$, $F \rightarrow F^\dagger$, $u_\sigma \rightarrow -u_\sigma$, and $X \rightarrow -X$.

In the absence of interaction, $E_C = \tilde{E}_C = 0$, the operators F and F^\dagger commute with the Hamiltonian, the correlator $K(t) = 1$, and the conductance is not renormalized: $G_L = G_l$. We show below that the time dependence of the correlator $K(t)$ is non-trivial if \tilde{E}_C , $E_C > 0$. Consequently the effective conductance G_L is renormalized and acquires a power-law temperature dependence at $T \ll \tilde{E}_C$.

To calculate $K(t)$, we use a unitary transformation \hat{U} which shifts the origin of the electron liquid displacement u_σ by a distance which depends on n_L ,

$$\hat{U} = \exp \left[i \left(\frac{\alpha}{2} X - \frac{1+\lambda}{2} n_L \right) \Theta \right], \quad (26)$$

$$\Theta = \frac{1}{2\hbar n_0} \int_{-\infty}^{\infty} [p_\uparrow(y) + p_\downarrow(y)] dy. \quad (27)$$

Upon the transformation (26) the Hamiltonian is simplified, and operator F acquires a phase factor:

$$\hat{U}^\dagger (H_0 + H_C) \hat{U} = H_0 + E_C (n_L - 2X)^2 + 4\tilde{E}_C n_0^2 [u_\uparrow(0) + u_\downarrow(0)]^2, \quad (28)$$

$$\hat{U}^\dagger F \hat{U} = F \exp \left(-i \frac{1+\lambda}{2} \Theta \right). \quad (29)$$

The correlation function (25) now factorizes, $K = K_F K_\Theta$. The factor $K_F = \langle F(t) F^\dagger(0) \rangle$ is easily found:

$$K_F = \langle e^{-iE_C(2n_L+1-4X)t/\hbar} \rangle = \frac{e^{-i4E_C(X^*-X)t/\hbar}}{e^{4E_C(X^*-X)/T} + 1}. \quad (30)$$

In the derivation of Eq. (30) we assumed that the gate voltage X is close to one of the peak positions $X^* = (2n+1)/4$, see Eq. (10), and that the temperature is much smaller than E_C so that only two states are involved. The calculation of K_Θ is also straightforward, as the Hamiltonian (28) is quadratic in the bosonic variables, and the exponent in (29) is linear in these variables:

$$\begin{aligned} K_\Theta(t) &= \left\langle \exp \left[-i \frac{1+\lambda}{2} \Theta(t) \right] \exp \left[i \frac{1+\lambda}{2} \Theta(0) \right] \right\rangle \\ &= \exp \left\{ -\frac{(1+\lambda)^2}{4} \langle [\Theta(0) - \Theta(t)] \Theta(0) \rangle \right\} \\ &= \left\{ \frac{\pi^2 T}{2ie^C \tilde{E}_C} \frac{1}{\sinh[\pi T(t-i\delta)/\hbar]} \right\}^{(1+\lambda)^2/4} \end{aligned} \quad (31)$$

One can now substitute $K = K_F K_\Theta$ into Eq. (24) to find the renormalized conductance,

$$G_L = \frac{G_l}{2} \left(\frac{\pi^2 T}{e^C \tilde{E}_C} \right)^{\eta_L} F_{\eta_L} \left(\frac{4E_C(X - X^*)}{T} \right), \quad (32)$$

where $\eta_L = (1 + \lambda)^2/4$. The peak shape is given by the function $F_\eta(x)$ defined as

$$F_\eta(x) = \frac{1}{\cosh(x/2)} \frac{|\Gamma(1 + \frac{\eta}{2} + \frac{ix}{2\pi})|^2}{\Gamma(2 + \eta)}. \quad (33)$$

The tunneling into the double-dot system is suppressed at low temperatures, $G_L \propto T^{\eta_L}$. The origin of this suppression is Anderson's orthogonality catastrophe. The tunneling of an electron into the left dot results in a significant change of the ground state of the double-dot system, and the new ground state is orthogonal to the old one, leading to the suppression of tunneling. Indeed, after the tunneling process has changed the charge of the left dot by e , charge $q_\uparrow = q_\downarrow = e(1 + \lambda)/4$ must be transferred to the right dot in each spin channel to minimize the electrostatic energy. The orthogonality of the two ground states results in a power-law suppression of the tunneling density of states, $G \propto T^{\eta_L}$, where the exponent can be related to the charges q_σ as²² $\eta_L = 2 \sum_\sigma (q_\sigma/e)^2$, in agreement with Eq. (32).

The tunneling through the right barrier can be treated in the same manner, and the result for the renormalized conductance G_R can be found by replacement $G_l \rightarrow G_r$ and $\eta_L \rightarrow \eta_R = (1 - \lambda)^2/4$ in Eq. (32). After the renormalized conductances G_L and G_R are found, we can use the master equation approach similar to the one outlined in Appendix B, and find the total conductance:

$$G = \frac{G_L G_R}{G_L + G_R}. \quad (34)$$

At $T \rightarrow 0$ the smallest of the two conductances, G_L and G_R , controls G , which means that the peak value of G is proportional to T^η , with $\eta = (1 + |\lambda|)^2/4$. Depending on the geometry of the system, the parameter λ may vary from -1 to 1 , and is 0 in the symmetric case. Therefore the exponent of the temperature dependence η varies from $1/4$ in the symmetric case to 1 in the most asymmetric case.

C. Intermediate strength of tunneling between the dots

In the previous two sections we considered the cases of weak and strong tunneling between the dots. We

found that for a symmetric system in the weak tunneling limit the conductance peak heights are temperature independent, whereas in the strong tunneling limit the peak heights are suppressed as $T^{1/4}$. For the asymmetric case we discovered the T^2 dependence of the peak conductance in the weak tunneling case, and T^η with geometry-dependent exponent, $\frac{1}{4} \leq \eta \leq 1$, for strong tunneling. In this section we show that in the intermediate regime the power-law temperature dependence of the peak conductance persists and consider the corresponding exponents.

We start with the case of symmetric geometry. The weak tunneling result (11) was obtained in the framework of the master equation approach with the interdot tunneling rate calculated to first order in G_0 . It is known,¹⁴ however, that the higher-order terms of the perturbation theory give rise to a logarithmic renormalization of the conductance G_0 . This renormalization becomes important at temperatures $T \lesssim T_K \simeq \tilde{E}_C \exp[-(\pi^3 e^2/4\hbar G_0)^{1/2}]$. Therefore at $G_0 \ll e^2/h$ the result (11) is applicable only in the range of temperatures $T_K \ll T \ll E_C$.

A similar argument can be applied in the vicinity of the strong tunneling limit. Indeed, it was shown¹⁵ that at $G_0 = 2(e^2/h)(1 - \mathcal{R})$ a weak reflection in the constriction is a relevant perturbation which grows at low temperatures and becomes strong at $T \lesssim E_C \mathcal{R}$. Thus the $T^{1/4}$ -dependence of the peak conductance found in Sec. III B holds only in the temperature range $E_C \mathcal{R} \ll T \ll E_C$.

To consider the effect of weak backscattering $\mathcal{R} \ll 1$ in the constriction on the low-temperature asymptotics, $T \ll E_C \mathcal{R}$, of the peak conductance, we complement the Hamiltonian (18)–(20) with a scattering term H' . In bosonic representation H' has the form¹⁵

$$H' = -\frac{D}{\pi} \sqrt{\mathcal{R}} \sum_\sigma \cos[2\pi n_0 u_\sigma(0) - \phi_0], \quad (35)$$

where the phase shift ϕ_0 is added to account for the possibility of an asymmetric location of the scatterer with respect to the center of the constriction. One can then repeat most of the discussion of Sec. III B with the new Hamiltonian. Upon the unitary transformation (26) the backscattering term takes the form

$$\begin{aligned} \hat{U}^\dagger H' \hat{U} &= -\frac{D}{\pi} \sqrt{\mathcal{R}} \sum_\sigma \cos \left[2\pi n_0 u_\sigma(0) - \phi_X + \frac{\pi}{2} (1 + \lambda) n_L \right] \\ &= -\frac{2D}{\pi} \sqrt{\mathcal{R}} \cos \left\{ \pi n_0 [u_\uparrow(0) + u_\downarrow(0)] - \phi_X + \frac{\pi}{2} (1 + \lambda) n_L \right\} \cos \{ \pi n_0 [u_\uparrow(0) - u_\downarrow(0)] \}, \end{aligned} \quad (36)$$

where $\phi_X = \phi_0 + \frac{\pi}{2}\alpha X$.

Unlike other terms (28) of the Hamiltonian, the backscattering term (36) shows non-trivial dependence not only on the sum of the displacements $u_\uparrow + u_\downarrow$, but also on their difference $u_\uparrow - u_\downarrow$. At low temperatures $T \ll E_C$, one is only interested in the low-energy behavior of the system. In this regime the fluctuations of the charge of the dot $n_0[u_\uparrow(0) + u_\downarrow(0)]$ are frozen due to the charging energy term in Eq. (28) and can be integrated out. The resulting backscattering term has the form

$$\hat{U}^\dagger H' \hat{U} \simeq -\sqrt{\frac{8e^C E_C D\mathcal{R}}{\pi^3}} \cos\left[\phi_X - \frac{\pi}{2}(1+\lambda)n_L\right] \times \cos\{\pi n_0[u_\uparrow(0) - u_\downarrow(0)]\}, \quad (37)$$

cf. Ref. 15. Since the operators F and F^\dagger do not commute with the backscattering term (37), the latter can affect the K_F component of the correlator $K(t)$ and the conductance of the left barrier (24). To find the effect of the backscattering on $K_F(t)$, we first discuss the influence of the operator (37) on the dynamics of the spin field $u_\uparrow - u_\downarrow$. One can easily show that the operator (37) is a relevant perturbation,²⁰ i.e., the amplitude of the cosine term grows at low energies. Thus at $T \rightarrow 0$ the spin field fluctuations are frozen at the value $n_0[u_\uparrow(0) - u_\downarrow(0)] = 0$ or 1 for the positive and negative values of $\cos[\phi_X - \frac{\pi}{2}(1+\lambda)n_L]$, respectively.

When an electron tunnels into the double-dot system through the left barrier, the value of n_L changes from 0 to 1. Thus the prefactor in Eq. (37) is proportional to either $\cos\phi_X$ or $\cos[\phi_X - \frac{\pi}{2}(1+\lambda)n_L]$. If the two cosines have the same sign, the increase of n_L described by the operator F^\dagger does not affect the long-time dynamics of the spin mode, which remains pinned at the origin with the same value of $u_\uparrow(0) - u_\downarrow(0)$. In this case the time dependence of $K_F(t)$ is not affected by the backscattering and the conductance G_L is still given by Eq. (32), with a different prefactor which we do not calculate here. On the other hand, if the signs of $\cos\phi_X$ and $\cos[\phi_X - \frac{\pi}{2}(1+\lambda)n_L]$ are different, the change of n_L shifts the boundary condition for the spin mode from $n_0[u_\uparrow(0) - u_\downarrow(0)] = 0$ to 1. An abrupt change of the boundary condition creates a disturbance in a 1D bosonic field that decays slowly, giving rise to power-law time dependences of electronic Green's functions.²³ Thus the correlator $K_F(t)$ acquires an additional time-dependent factor^{20,25} $K_s(t) \propto \pi T/i \sinh[\pi T(t - i\delta)/\hbar]$. According to Eq. (24), such a modification of $K(t)$ not only changes the prefactor in Eq. (32), but also replaces the exponent η_L by $\eta_L + 1$. Thus depending on the values of ϕ_X and λ , the backscattering either does not affect the temperature dependence of the renormalized conductance $G_L \propto T^{(1+\lambda)^2/4}$ or replaces it with a stronger one, $G_L \propto T^{1+(1+\lambda)^2/4}$.

The latter result can be easily interpreted in terms of the orthogonality catastrophe. Indeed, as we saw, the tunneling of an electron into the left dot leads to the

transfer of charge $q_\uparrow + q_\downarrow = e(1+\lambda)/2$ through the constriction. On the other hand, if $n_0[u_\uparrow(0) - u_\downarrow(0)]$ changes from 0 to 1, the transferred spin is $(q_\uparrow - q_\downarrow)/2e = \frac{1}{2}$. Thus we can easily evaluate the charge transferred in each of the spin channels,

$$q_{\uparrow,\downarrow} = e \left(\pm \frac{1}{2} + \frac{1+\lambda}{4} \right). \quad (38)$$

The suppression of the tunneling density of states is described by the power law $\nu \propto \epsilon^{\eta_L}$, where the exponent is given by²² $\eta_L = 2 \sum_\sigma (q_\sigma/e)^2$. From Eq. (38) we now find

$$\eta_L = 1 + \frac{(1+\lambda)^2}{4}, \quad (39)$$

which results in the power-law suppression of the conductance, $G_L \propto T^{1+(1+\lambda)^2/4}$.

To find the temperature dependence of the peaks in the conductance through the double-dot system, one has to find not only G_L , but also G_R . It is clear that when a tunneling process through the whole double-dot system is completed, exactly one electron is transferred through the constriction. Thus we conclude that the total transfer of charge after one electron has tunneled into the left dot and another one escaped from the right dot is $\Delta q = e$. Since the charge transferred through the constriction at the first step was $e(1+\lambda)/2$, the tunneling of an electron from the right dot must be accompanied by the transfer of charge $e(1-\lambda)/2$. We saw above that unlike charge, the spin is transferred in quantized portions $\Delta s = \frac{1}{2}$. Since the total transferred spin is $\frac{1}{2}$, we conclude that exactly one of the two tunneling events involved the transfer of spin. Therefore in the cases when the temperature dependence of G_L is given by $T^{(1+\lambda)^2/4}$ and $T^{1+(1+\lambda)^2/4}$, the conductance G_R behaves as $T^{1+(1-\lambda)^2/4}$ and $T^{(1-\lambda)^2/4}$, respectively. Finally, since the total conductance is given by the smaller of G_L and G_R , we find

$$G \propto \begin{cases} T^{1+\frac{(1-\lambda)^2}{4}}, & \text{if } \cos\phi_X \cos[\phi_X - \frac{\pi}{2}(1+\lambda)n_L] > 0, \\ T^{1+\frac{(1+\lambda)^2}{4}}, & \text{if } \cos\phi_X \cos[\phi_X - \frac{\pi}{2}(1+\lambda)n_L] < 0. \end{cases} \quad (40)$$

To determine which option applies to a particular peak, one needs a detailed knowledge of the microscopic structure of the double-dot system. It is clear, however, that for nearly symmetric geometries the parameter λ , which is determined only by the electrostatics of the system, should be small: $\lambda \ll 1$. *In this case we predict the temperature dependence $G \propto T^{5/4}$ for all peaks, independent of the microscopic structure of the double-dot.*

The temperature dependence of peak heights has been investigated experimentally by N. van der Vaart *et al.*²⁶ In the regime of weak reflection, the power-law fit to the data in the temperature interval $100\text{mK} < T < 1\text{K}$ gave $\eta = 0.8-1.2$, which is slightly less than our result $\eta = 1.25$ for the symmetric geometry.

The result (40) shows that the presence of even weak backscattering in the constriction gives rise to a large correction $\Delta\eta \sim 1$ to the exponent in the power-law temperature dependence $G \propto T^\eta$ of the peak conductance. In the derivation of Eq. (40) we assumed that the backscattering is weak, $\mathcal{R} \ll 1$. As the backscattering grows, it further affects the temperature dependence. Indeed, so far we assumed that the presence of the backscattering only creates a boundary condition for the spin mode, $u_\uparrow - u_\downarrow$, and does not affect the charge mode, $u_\uparrow + u_\downarrow$. However, from the studies^{14,15} of a single dot connected to a large lead it is known that the backscattering does affect the charge transferred through the constriction. One can attempt to generalize the result (40) to the case of arbitrary \mathcal{R} by introducing the value Q_t of the charge transferred through the constriction after an electron tunnels into the left dot. It is clear from the derivation of Eq. (39) that the second term there is actually Q_t/e , i.e.,

$$\eta_L = 1 + \left(\frac{Q_t}{e}\right)^2. \quad (41)$$

At $\mathcal{R} \rightarrow 0$ the correction to the electrostatic value $Q_t = e(1 + \lambda)/2$ of the transferred charge is small,¹⁵ $\Delta Q_t \sim \mathcal{R} \ln \frac{1}{\mathcal{R}}$, which justifies the approximation (39).

It is interesting to apply Eq. (41) to the weak-tunneling limit $\mathcal{R} \rightarrow 1$, considered in Sec. III A. In the asymmetric case we demonstrated that the temperature dependence of the conductance is given by Eq. (17). In the derivation we assumed that because of the high barrier separating the dots, there is no transfer of electrons between the dots after an electron tunnels into the left dot. This means that both Q_t and Δs vanish, $\eta_L = 0$, and the conductance G_L is not suppressed at $T \rightarrow 0$. On the other hand, when an electron escapes to the right lead, it must go through the constriction, leading to $Q_t = e$ and $\Delta s = \frac{1}{2}$. As a result, the relation for η_R similar to Eq. (41) will give $\eta_R = 2$, which leads to the quadratic temperature dependence (17) of the linear conductance.

In our approach the shape of the peak is obtained from Eq. (24) by substitution $K(t) \propto \{\pi T/i \sinh[\pi T(t - i\delta)/\hbar]\}^\eta$. As a result the shape of the peak is always uniquely related to its temperature dependence,

$$G \propto T^\eta F_\eta \left(\frac{\varepsilon}{T}\right), \quad (42)$$

where F_η is defined by Eq. (33), and ε is proportional to the deviation of the gate voltage from the peak center. One can easily check that the peak shape (17) in the weak-tunneling limit does coincide with $F_2(\varepsilon/T)$.

IV. CONCLUSIONS

In this paper we studied electron tunneling through a system of two quantum dots connected by a constriction. Tuning the conductance G_0 of this constriction, one may control the quantum charge fluctuations between the dots

and thus affect the Coulomb blockade phenomenon that develops at a sufficiently low temperature, $T \lesssim E_C$. The positions of the peaks in linear conductance, $G(V_g)$, depend on the value of G_0 , and in the limit $G_0 \rightarrow 2e^2/h$ the peaks become equidistant (Section II). A striking result, however, is that the height and shape of the peaks also evolve significantly with G_0 , and remain non-trivial even in the limit of a reflectionless constriction, $G_0 \rightarrow 2e^2/h$. We have demonstrated that at any G_0 , except a special case of small G_0 in a symmetric two-dot system (Section III A), the peak conductance is a power-law function of temperature T . The exponent of the power law depends on the charge re-distribution between the dots that accompanies the electron transport through the two dots. Both this exponent and the explicit peak shapes depend on the dots' geometry, as well as G_0 (Sections III B and III C). The suppression of conductance at low temperature and bias can be understood in quite general terms as an Anderson orthogonality catastrophe caused by the re-distribution of charge (see Sections III B, III C), and the same exponents should describe the bias dependence of the differential conductance at $T = 0$.

In deriving our results, we assumed that the incoming electron dwells in a dot for a long time $t_d \gg \hbar/T$ before reaching the constriction that connects the dots. In a generic situation of a dot lacking a special symmetry, the electron bounces off the walls many times, before it gets to the constriction. The dwelling time is determined by the level spacing, $t_d \sim \hbar/\delta E$. Therefore, the results we presented in Section III are valid in the temperature interval $\delta E < T < E_C$. For typical parameters, this interval allows one to vary the temperature by at least one decade.

The effect of quantum charge fluctuations on the ground state energy has been recently demonstrated experimentally.^{4,5} The data of Waugh *et al.*⁴ is in a quantitative agreement with the present theory.¹² The temperature dependence of the peak conductance, which is related to the dynamics of the charge re-distribution, was studied in a very recent experiment by N. van der Vaart *et al.*²⁶ The temperature dependence exponent found experimentally in the regime of weak reflection, $\eta = 0.8-1.2$, is somewhat smaller than the theoretical value $\eta = 1.25$ we find for this case.

ACKNOWLEDGMENTS

The work at MIT was sponsored by Joint Services Electronics Program Contract DAAH04-95-1-0038 and at the University of Minnesota by NSF Grant DMR-9423244. K.M. and L.G. acknowledge the hospitality of the Aspen Center for Physics, where this work was completed.

APPENDIX A: DERIVATION OF THE ELECTROSTATIC ENERGY EQ. (4)

In this section we find the electrostatic energy of the double dot structure in terms of the capacitances of the individual dots and the gate voltage. To describe the electrostatics of the physical structure shown schematically in Fig. 1, we introduce the circuit diagram in Fig. 4. The electrostatics is determined by the gate voltage V_g and 5 capacitances— C_1 and C_2 are the capacitances of the dots to the gate, C_3 is the capacitance between the dots, and C_4 and C_5 are the capacitances of the dots to everything else.

In terms of the charge on each capacitor, the electrostatic energy is

$$U = \frac{q_1^2}{2C_1} + \frac{q_2^2}{2C_2} + \frac{q_3^2}{2C_3} + \frac{q_4^2}{2C_4} + \frac{q_5^2}{2C_5} - q_1V_g - q_2V_g. \quad (\text{A1})$$

The number of electrons on each dot is given by the sum of the charges on the appropriate three capacitors:

$$-eN_1 = q_1 + q_3 + q_4, \quad (\text{A2})$$

$$-eN_2 = q_2 - q_3 + q_5. \quad (\text{A3})$$

We now must minimize the energy Eq. (A1) at fixed values of V_g , N_1 , and N_2 and evaluate the energy at this minimum. The result has the form (4) [up to an irrelevant constant], and we now give explicit expressions for the parameters in this equation.

First, the energy involved in changing the total charge on the double-dot system is given simply by the total capacitance of the double-dot to the external world. Introducing the external capacitance

$$C_{\text{ext}} \equiv C_1 + C_2 + C_4 + C_5, \quad (\text{A4})$$

we find

$$E_C = \frac{e^2}{2C_{\text{ext}}}. \quad (\text{A5})$$

The coupling of the total charge to the gate is given by the capacitance to the gate,

$$X = \frac{-(C_1 + C_2)V_g}{2e}. \quad (\text{A6})$$

Turning to asymmetric structures, we find that the fractional asymmetry of the capacitances determines the parameter λ ,

$$\lambda = (C_2 + C_5 - C_1 - C_4)/C_{\text{ext}}. \quad (\text{A7})$$

In terms of this asymmetry parameter, we find that the charging energy for transfer from one dot to the other is

$$\tilde{E}_C = \frac{e^2}{2[C_{\text{ext}}(1 - \lambda^2) + 4C_3]}, \quad (\text{A8})$$

and that the coupling of this excitation to the gate is given by

$$\alpha = 2 \left(\lambda + \frac{C_1 - C_2}{C_1 + C_2} \right). \quad (\text{A9})$$

This completely specifies the electrostatic problem.

APPENDIX B: MASTER EQUATION TECHNIQUE FOR THE CONDUCTANCE PEAKS

In this Appendix we derive the expression (11) for the conductance peaks in the symmetric case. We restrict ourselves to the case of temperatures which are much smaller than E_C , but can be of the order of $E_C(X_+^* - X_-^*)$. For simplicity we assume that the gate voltage X is close to $\frac{1}{2}$, so that only the pair of peaks centered at X_+^* and X_-^* given by Eq. (6) with $n = 0$ should be considered. In this regime only the states with charges 0, e , and $2e$ should be taken into account. Clearly, one has four states, which can be denoted as 0, l , r , and 2, where l and r describe the two states with charge e on the left and right dot respectively.

We start with introducing the probabilities of occupation of the four states, which satisfy the obvious condition: $w_0 + w_l + w_r + w_2 = 1$. The rate of transitions from state 0 to state l , which are caused by tunneling of an electron through the left barrier, is given by

$$\begin{aligned} \frac{1}{\tau_{0 \rightarrow l}} &= w_0 \frac{2\pi}{\hbar} \sum_{kp} |t_{pk}|^2 n_k (1 - n_p) \\ &\quad \times \delta(\epsilon_k + eV + E_0 - \epsilon_p - E_1) \\ &= \frac{G_l}{e^2} w_0 f(E_1 - E_0 - eV). \end{aligned} \quad (\text{B1})$$

Here t_{pk} is the matrix element of tunneling from the state k in the left lead to the state p in the left dot, $n_{k(p)}$ and $\epsilon_{k(p)}$ are the corresponding Fermi occupation numbers and energies, $E_0(X)$ and $E_1(X)$ are the values of the ground state energy of the double-dot system with charge 0 and 1, the function $f(x)$ is defined as

$$f(x) = \frac{x}{e^{x/T} - 1}. \quad (\text{B2})$$

In deriving Eq. (B1) we assumed the bias V applied to the left lead. In a similar way one can find the rates of all other transitions.

In a stationary state the time derivatives of the occupation probabilities of all the four charge states of the system vanish. This gives us three independent equations $\dot{w}_l = \dot{w}_r = \dot{w}_2 = 0$, which can be written in the following form:

$$G_l[w_0f(\varepsilon_1 - eV) - w_lf(-\varepsilon_1 + eV)] + G_0f(0)[w_r - w_l] + G_r[w_2f(-\varepsilon_2) - w_lf(\varepsilon_2)] = 0, \quad (3)$$

$$G_r[w_0f(\varepsilon_1) - w_rf(-\varepsilon_1)] + G_0f(0)[w_l - w_r] + G_l[w_2f(-\varepsilon_2 + eV) - w_rf(\varepsilon_2 - eV)] = 0, \quad (4)$$

$$G_l[w_rf(\varepsilon_2 - eV) - w_2f(-\varepsilon_2 + eV)] + G_r[w_lf(\varepsilon_2) - w_2f(-\varepsilon_2)] = 0. \quad (5)$$

Here we have introduced

$$\varepsilon_1 \equiv E_1(X) - E_0(X) = 4E_C(X_-^* - X),$$

$$\varepsilon_2 \equiv E_2(X) - E_1(X) = 4E_C(X_+^* - X).$$

The current I can be also expressed in terms of occupation probabilities w_i . In a stationary state, currents through all the junctions are equal. Considering the current through the link between the dots, we can express I in the following form:

$$I = \frac{G_0}{e} f(0)(w_l - w_r). \quad (6)$$

The equations (3)–(5) must hold at any bias. Since we are interested in linear regime $eV \ll T$, we can differentiate equations (3)–(5) and replace them by the system of equations for the derivatives w'_0 , w'_l , w'_r , and w'_2 of the occupation probabilities over bias:

$$R_l \left(\frac{w'_0}{w_0} - \frac{w'_l}{w_l} + \frac{e}{T} \right) + R_0 \left(\frac{w'_r}{w_r} - \frac{w'_l}{w_l} \right) + R_{2r} \left(\frac{w'_2}{w_2} - \frac{w'_l}{w_l} \right) = 0, \quad (7)$$

$$R_r \left(\frac{w'_0}{w_0} - \frac{w'_r}{w_r} \right) + R_0 \left(\frac{w'_l}{w_l} - \frac{w'_r}{w_r} \right) + R_{2l} \left(\frac{w'_2}{w_2} - \frac{w'_r}{w_r} - \frac{e}{T} \right) = 0, \quad (8)$$

$$R_{2l} \left(\frac{w'_r}{w_r} - \frac{w'_2}{w_2} + \frac{e}{T} \right) + R_{2r} \left(\frac{w'_l}{w_l} - \frac{w'_2}{w_2} \right) = 0, \quad (9)$$

cf. Ref. 27. Here w_i are the equilibrium occupation probabilities, and we introduced the equilibrium rates:

$$R_l = w_0 G_l f(\varepsilon_1) = w_l G_l f(-\varepsilon_1) = G_l f(\varepsilon_1) Z^{-1}, \quad (10)$$

$$R_r = w_0 G_r f(\varepsilon_1) = w_r G_r f(-\varepsilon_1) = G_r f(\varepsilon_1) Z^{-1}, \quad (11)$$

$$R_0 = w_r G_0 f(0) = w_l G_0 f(0) = T G_0 e^{-\varepsilon_1/T} Z^{-1}, \quad (12)$$

$$R_{2l} = w_r G_l f(\varepsilon_2) = w_2 G_l f(-\varepsilon_2) = G_l f(\varepsilon_2) e^{-\varepsilon_1/T} Z^{-1}, \quad (13)$$

$$R_{2r} = w_l G_r f(\varepsilon_2) = w_2 G_r f(-\varepsilon_2) = G_r f(\varepsilon_2) e^{-\varepsilon_1/T} Z^{-1}, \quad (14)$$

with the equilibrium partition function $Z = 1 + 2 \exp(-\varepsilon_1/T) + \exp[-(\varepsilon_1 + \varepsilon_2)/T]$. Since the sum of occupation probabilities always equals one, there are only three independent variables in the system (7)–(9).

Using Eq. (6), we can also express the conductance

$$G = R_0 \left(\frac{w'_l}{w_l} - \frac{w'_r}{w_r} \right) \quad (15)$$

in terms of the solution of the system (7)–(9). In the limit $G_0 \gg G_l, G_r$, we find:

$$G = \frac{1}{T} \left(\frac{R_l R_r}{R_l + R_r} + \frac{R_{2l} R_{2r}}{R_{2l} + R_{2r}} \right). \quad (16)$$

Substitution of the rates (10)–(14) into (16) yields the formula (11).

¹ *Single Charge Tunneling*, edited by H. Grabert and M.H. Devoret (Plenum Press, New York, 1992).

² M.A. Kastner, Rev. Mod. Phys. **64**, 849 (1992); E.B. Foxman, P.L. McEuen, U. Meirav, N.S. Wingreen, Y. Meir, P.A. Belk, N.R. Belk, M.A. Kastner, and S.J. Wind, Phys. Rev. B **47**, 10020 (1993).

³ L.I. Glazman and R.I. Shekhter, J. Phys. CM **1**, 5811 (1989).

⁴ F.R. Waugh, M.J. Berry, D.J. Mar, R.M. Westervelt, K.C. Campman, and A.C. Gossard, Phys. Rev. Lett. **75**, 705 (1995).

⁵ L.W. Molenkamp, K. Flensberg, and M. Kemerink, Phys. Rev. Lett. **75**, 4282 (1995).

⁶ N.C. van der Vaart, S.F. Godijn, Y.V. Nazarov, C.J.P.M. Harmans, J.E. Mooij, L.W. Molenkamp, and C.T. Foxon, Phys. Rev. Lett. **74**, 4702 (1995).

⁷ R.H. Blick, R.J. Haug, J. Weis, D. Pfannkuche, K. v. Klitzing, and K. Eberl, Phys. Rev. B, January 15 (1996).

⁸ F. Hofmann, T. Heinzel, D.A. Wharam, J.P. Kotthaus, G. Böhm, W. Klein, G. Tränkle, and G. Weimann, Phys. Rev. B **51**, 13872 (1995).

⁹ I.M. Ruzin, V. Chandrasekhar, E.I. Levin, and L.I. Glazman, Phys. Rev. B **45**, 13469 (1992).

¹⁰ C.A. Stafford and S. Das Sarma, Phys. Rev. Lett. **72**, 3590 (1994).

¹¹ G. Klimeck, G. Chen, and S. Datta, Phys. Rev. B **50**, 2316 (1994).

¹² K.A. Matveev, L.I. Glazman, and H.U. Baranger, Phys. Rev. B, January 15 (1996).

¹³ J.M. Golden and B.I. Halperin, preprint (5/95).

¹⁴ See Sec. 4 of L.I. Glazman and K.A. Matveev, Zh. Eksp. Teor. Fiz. **98**, 1834 (1990) [Sov. Phys. JETP **71**, 1031 (1990)] and K.A. Matveev, Zh. Eksp. Teor. Fiz. **99**, 1598 (1991) [Sov. Phys. JETP **72**, 892 (1991)].

¹⁵ K.A. Matveev, Phys. Rev. B **51**, 1743 (1995).

¹⁶ See, e.g., C. W. J. Beenakker and H. van Houten in *Solid State Physics*, Vol. 44, edited by H. Ehrenreich and D. Turnbull (Academic Press, New York, 1991) pp. 109-125.

¹⁷ D. V. Averin and A. A. Odintsov, Phys. Lett. A **140**, 251 (1989).

¹⁸ D.V. Averin and Yu.V. Nazarov, Phys. Rev. Lett. **65**, 2446 (1990).

¹⁹ K. Flensberg, Phys. Rev. B **48**, 11156 (1993); Physica B **203**, 432 (1994).

²⁰ A. Furusaki and K.A. Matveev, Phys. Rev. B, December 15; Phys. Rev. Lett. **75**, 709 (1995).

²¹ G.-L. Ingold and Yu.V. Nazarov, in Ref. 1, pp. 21-107.

²² This expression for η_L follows from the standard expression of the exponent for the orthogonality catastrophe $\eta = \sum (\delta_m/\pi)^2$ in terms of the phase shifts,^{23,24} if one takes into account the Friedel sum rule $\delta_m = \pi q_m/e$ and the fact that each spin channel corresponds to two semi-infinite 1D modes.

²³ K. Schotte and U. Schotte, Phys. Rev. **182**, 479 (1969).

²⁴ P. Nozières and C.T. de Dominicis, Phys. Rev. **178**, 1097 (1969).

²⁵ We have observed a similar effect in Sec. III B, where the change of n_L caused a shift of the boundary condition for the charge mode and resulted in the contribution (31) to $K(t)$.

²⁶ N. van der Vaart, *Single Electron Transport and Quantum Confinement in Semiconductor Nanostructures*, Thesis, Delft, October, 1995.

²⁷ H. Bahlouli, K.A. Matveev, D. Ephron, and M.R. Beasley, Phys. Rev. B **49**, 14496 (1994).

FIG. 1. Schematic view of the double quantum dot system. The dots are formed by applying negative voltage to the gates (shaded); the solid line shows the boundary of the 2D electron gas (2DEG). V_l and V_r create tunnel barriers between the dots and the leads while V_0 controls the transmission coefficient through the constriction connecting the dots.

FIG. 2. The evolution of the split peaks with temperature described by Eq. (11). The reference point for the gate voltage is chosen to be $(X_-^* + X_+^*)/2$, and the gate voltage is plotted in units of $(X_+^* - X_-^*)/2$. The peak splitting is observable at a sufficiently low temperature, $\beta \equiv 4E_C/T \gtrsim 2$.

FIG. 3. The conductance as a function of dimensionless gate voltage X in the asymmetric weak-coupling case. Note the correlation between the modulation of the peak height and the separation of adjacent peaks: when the peaks are high the splitting is small, while when the peaks are small they are well separated. The parameters used in Eq. (17) to produce this plot are $\alpha = 0.155$ and $T/E_C = 0.07$.

FIG. 4. Equivalent electrostatic circuit for the double-dot device of Fig. 1 in equilibrium.

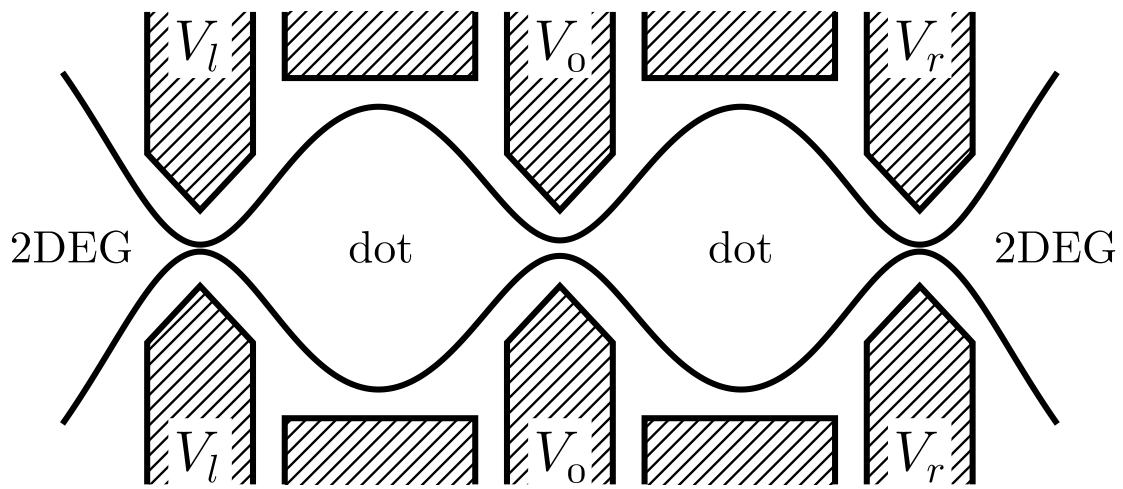

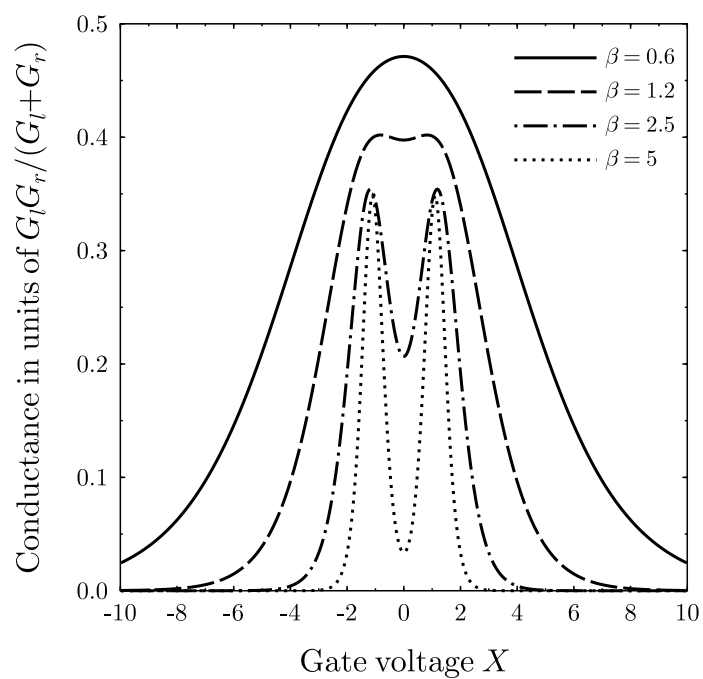

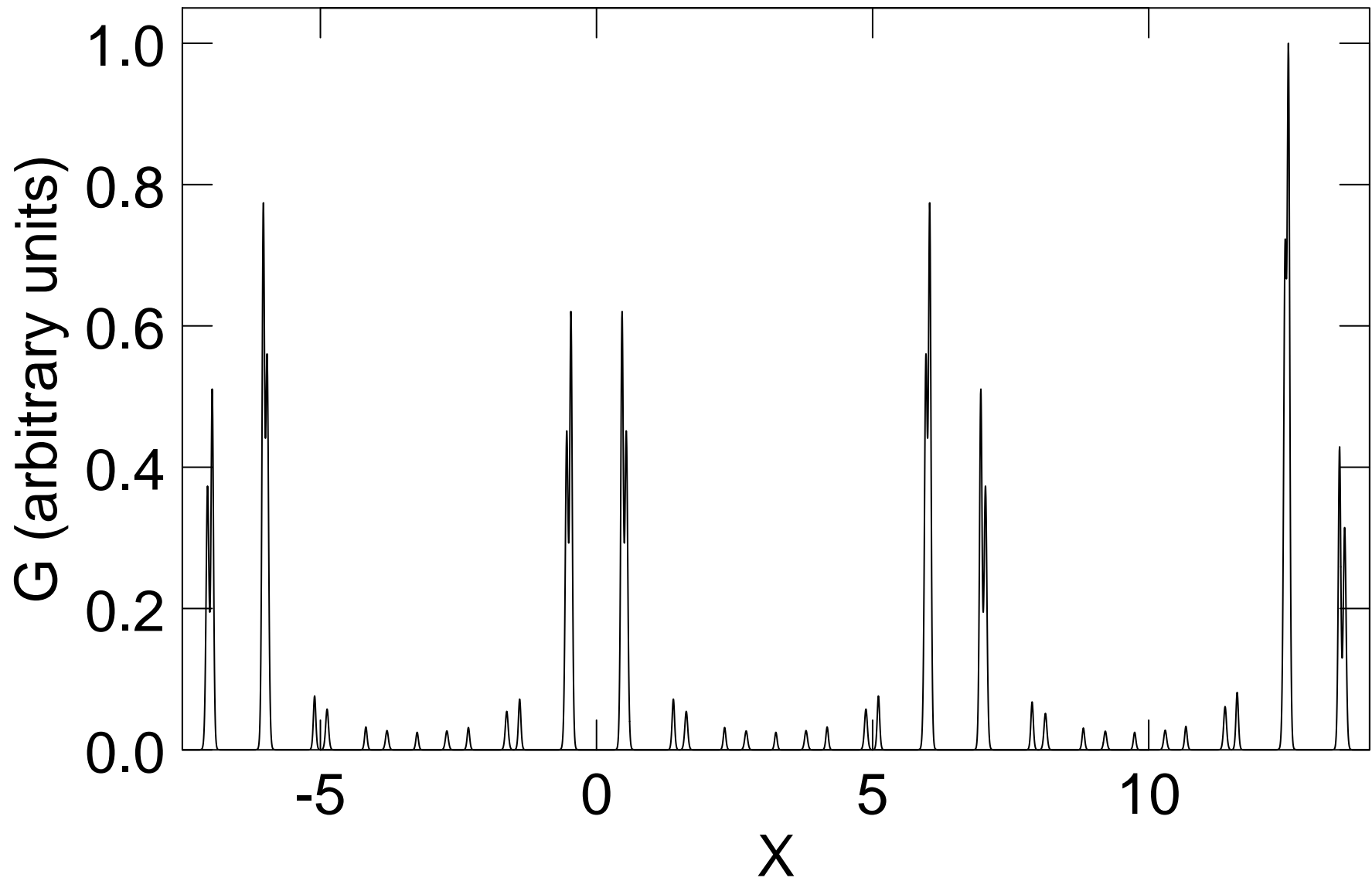

Fig. 3 [Matveev, Glazman, and Baranger]

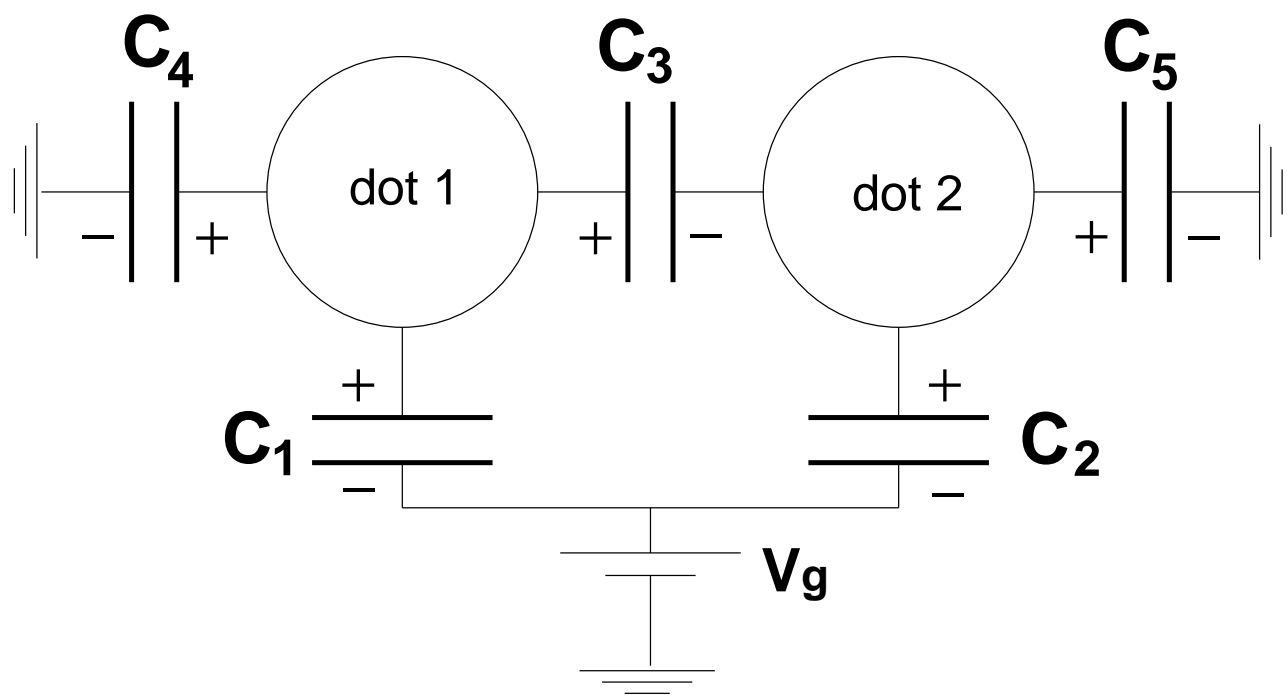

Fig. 4 [Matveev, Glazman, and Baranger]