

# Crosstalk Correction in Atomic Force Microscopy

Á. Hoffmann, T. Jungk, and E. Soergel\*

*Institute of Physics, University of Bonn, Wegelerstraße 8, 53115 Bonn, Germany*

(Dated: September 4, 2018)

Commercial atomic force microscopes usually use a four-segmented photodiode to detect the motion of the cantilever via laser beam deflection. This read-out technique enables to measure bending and torsion of the cantilever separately. A slight angle between the orientation of the photodiode and the plane of the readout beam, however, causes false signals in both readout channels, so-called crosstalk, that may lead to misinterpretation of the acquired data. We demonstrate this fault with images recorded in contact mode on ferroelectric crystals and present an electronic circuit to compensate for it, thereby enabling crosstalk-free imaging.

PACS numbers: 68.37.Ps, 07.79.-v, 77.65.-j

The atomic force microscope (AFM) has become a standard tool for determining the surface properties on the nanometer scale not only in physics but also in all life sciences. This is mainly due to its high versatility as it can detect various surface properties such as topography as well as e.g. frictional, electrostatic or magnetic interaction between tip and sample (see e.g. [1]). This feature of the AFM is even more attractive since those surface properties can be detected simultaneously by using an appropriate setup. Unfortunately an unambiguous separation of the different read-out channels is not generally assured, leading to crosstalk. Although commercially available AFM's are generally equipped with a powerful software for operation and subsequent image processing, a correction for crosstalk is not provided. In this contribution, we address the problem of crosstalk between the read-out channels for bending and torsion of the cantilever.

Figure 1 shows the notations used. The forces sensed by the tip can be out of plane (i) and in plane (ii) of the surface to be investigated. Whereas (i) leads to a bending of the cantilever, (ii) results either in torsion or in buckling, depending on the orientation of the force with respect to the axis of the cantilever. Note that bending

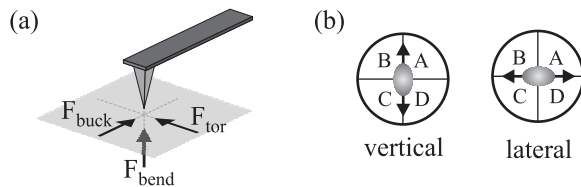

FIG. 1: (a) Forces acting on the tip.  $F_{bend}$ : bending of the cantilever due to forces out of plane,  $F_{buck}$  and  $F_{tor}$ : buckling and torsion of the cantilever due to forces in plane with the surface. (b) Readout with the position sensitive detector, left: vertical signal (bending & buckling), right: lateral signal (torsion).

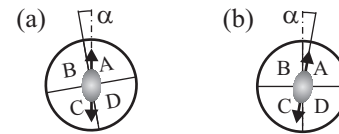

FIG. 2: Misalignment between read-out laser beam and the position sensitive detector. A rotation of the photodiode (a) affects the readout likewise a rotation of the plane of the laser beam (b). Both cause an angular mismatch  $\alpha$  that involves false signals due to crosstalk between vertical and lateral signals.

and buckling lead to a "vertical signal", i.e., the movement of the cantilever is detected as  $(A + B) - (C + D)$  at the position sensitive detector whereas torsion is seen as a "lateral signal" via  $(A + D) - (B + C)$ .

There are several reasons for crosstalk between the vertical and the lateral readout channel in AFM: (i) mechanically caused, (ii) originated by the electronics and (iii) due to a misalignment of the optical detection system. The first one (i) generally arises when mechanically hitting an edge at the surface while scanning, thereby twisting the cantilever. In some AFM's also the elongation of the tubescanner results in a change of the detection unit, thus, leading to false signals [2, 3]. Finally a mechanical coupling of the different motions of the cantilever can lead to crosstalk [4]. Mechanical crosstalk is in particular important when investigating samples with a pronounced topography. For reduction a low scanning speed together with a fast feedback loop is most appropriate. Note that on smooth sample surfaces mechanically caused crosstalk does not occur.

Concerning the crosstalk (ii) originating from electronics, a careful shielding of the signal wires seems most promising. This, however, can generally be assured by the manufacturer only, the user having no access to the electronics in the AFM head.

The last type of crosstalk (iii) is generated by a misalignment of the optical detection unit. The way to adjust the laser beam on the backside of the cantilever and, in a subsequent step, to center its reflection on the position sensitive detector (PSD) is most probably different

\*Electronic address: soergel@uni-bonn.de

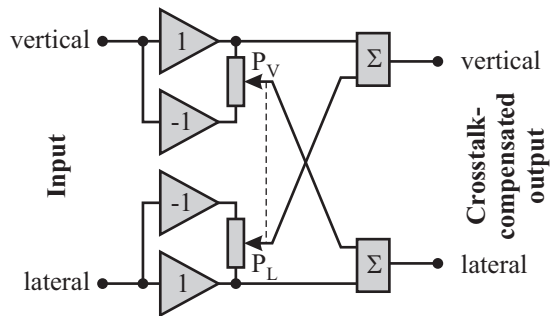

FIG. 3: Schematics of the electronic circuit used for crosstalk compensation.  $P_V$  and  $P_L$ : potentiometer for vertical and lateral crosstalk correction respectively.  $\Sigma$ : summing up of the signals.

for every AFM. In addition, to achieve a perfect alignment, it would be necessary to rotate the PSD thereby avoiding an angular mismatch  $\alpha$  between the axis of the PSD and the plane of the read-out laser beam (Fig. 2). The latter is given by the incoming laser beam and the one reflected from the cantilever. Although this problem is described in the literature [5], a rotation of the PSD is in general not possible. In case of a misalignment by the angle  $\alpha$  the correct vertical and lateral signals for bending and torsion ( $V$  and  $L$ ) are falsified to the measured signals ( $V_m$  and  $L_m$ ) via the rotation matrix as

$$\begin{bmatrix} V_m \\ L_m \end{bmatrix} = \begin{bmatrix} V \\ L \end{bmatrix} \begin{bmatrix} \cos \alpha & \sin \alpha \\ -\sin \alpha & \cos \alpha \end{bmatrix}. \quad (1)$$

To correct for this misalignment we realized an electronic circuit depicted in Fig. 3, thereby adding separately to every readout channel a component from the other channel with the adequate amplitude, adjustable via potentiometers. The crosstalk-corrected signals  $V_c$  and  $L_c$  can thus be calculated by

$$\begin{bmatrix} V_c \\ L_c \end{bmatrix} = \begin{bmatrix} V_m \\ L_m \end{bmatrix} \begin{bmatrix} 1 & -x \\ x & 1 \end{bmatrix} = \frac{1}{\cos \alpha} \begin{bmatrix} V \\ L \end{bmatrix} \quad (2)$$

with  $x = \tan \alpha$ . The circuit of Fig. 3 was realized with low-noise precision operational amplifiers (OP27) and applicable to frequencies  $> 1$  MHz. This is generally enough for standard AFM applications. Note that the corrected signals become larger than the real signals. Therefore the calibration of the system has to be performed after accomplishing the crosstalk correction or use an adjustable voltage divider at the output.

How to adjust the potentiometers  $P_V$  and  $P_L$ ? In a first step, the determination of the crosstalk is required. This can be achieved by retracting the tip from the surface and exciting the cantilever at its resonance frequency (with help of the piezo used for non-contact mode operation). The spring constants and accordingly the resonance frequencies for bending and torsion of a cantilever are different, thus using the adequate excitation frequency the

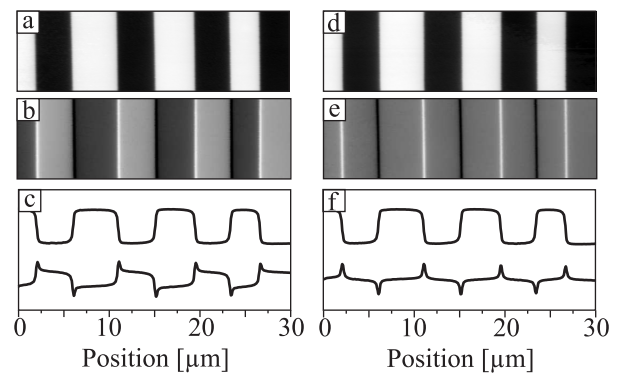

FIG. 4: Piezoresponse force microscopy images of periodically poled lithium niobate (PPLN). Left side with crosstalk and right side with compensated crosstalk ((a), (d): vertical signal, (b), (e): lateral signal, (c), (f): appropriate scanlines). The cantilever is orientated parallel to the PPLN stripes.

cantilever oscillates in its first bending mode only. In case of a perfect alignment of the optical detection unit  $L_m = 0$ , i.e., no lateral signal is detected. Otherwise the potentiometer  $P_L$  has to be adjusted to obtain  $L_m = 0$ . Since both channels suffer the same crosstalk, i.e., the same rotation  $\alpha$ ,  $P_V$  has to be set to the same value as  $P_L$ . Note that this procedure has to be repeated for every cantilever, and even for a new laser beam adjustment with the same cantilever.

To give an example of the efficiency of our electronic crosstalk compensator, we performed measurements on periodically poled lithium niobate (PPLN) crystals using the AFM in piezoresponse mode [6]. Using PPLN as a test sample has the advantage that the surface deformation at the domain boundaries caused by the converse piezoelectric effect has a height of only  $< 0.1$  nm over a length scale of  $\sim 100$  nm (with  $10 V_{pp}$  applied to the tip) [7]. Thus a mechanical crosstalk can be neglected. The vertical signal is known to be caused by the mechanical deformation of the sample via the converse piezoelectric effect. The lateral signal at the domain boundaries originates from the surface charges leading to electric fields orientated in plane of the surface [8]. The left side of Fig. 4 shows simultaneously recorded deflection (a) and torsion (b) of the cantilever, without crosstalk correction. In (c) scanlines of these two images are presented. Obviously also in the lateral channel the domain faces of PPLN are visible. Because the vertical signal having a much higher amplitude than the lateral signal, the reciprocal effect is not seen. When using crosstalk compensation (right side of Fig. 4) the lateral signal shows no contrast of the domain faces but only the boundaries are visible.

A crosstalk compensation as presented above could of course also be realized by an subsequent software processing of the recorded images. However, compared to the hardware solution proposed in this contribution, there are several drawbacks: (i) for the determination of the correction parameter (the angle  $\alpha$ ), a separate detection

of the vertical and the lateral signal amplitudes ( $V_m$  and  $L_m$ ) of the excited cantilever is required. Furthermore, their relative phase relation must be known to identify the sign of the necessary rotation. These signal parameters, however, are not accessible in general. (ii) For crosstalk compensation via software both images (lateral and vertical) are necessary since image processing takes only place after recording. (iii) This implies that a real-time monitoring of the data during image acquisition is not possible. (iv) Finally, a software based solution limits the possibilities to record freely chosen input signals (e.g. the outputs of two lock-in amplifiers as demonstrated in the above presented example). Note that the drawbacks as described above could be solved by the manufacturer with a software compensation during data acquisition and additional hardware modifications of the

control unit.

In this contribution we have demonstrated the effect of a misalignment of the optical detection unit on the recording of bending and torsion signals with AFM. We have furthermore proposed an electronic circuit to compensate for false signals caused by this type of crosstalk which can be incorporated to every AFM if the outputs of the position sensitive detector are directly accessible.

### Acknowledgments

Financial support of the DFG research unit 557 and of the Deutsche Telekom AG is gratefully acknowledged.

- 
- [1] E. Meyer, H. J. Hug, and R. Bennewitz "Scanning Probe Microscopy: The Lab on a Tip", Springer (2003)
  - [2] M. Varenberg, I. Etsion, and G. Halperin, *Rev. Sci. Instr.* **74**, 3569, (2003).
  - [3] J. Kwon, J. Hong, Y.-S. Kim, D.-Y. Lee, K. Lee, S.-M. Lee, and S.-I. Park *Rev. Sci. Instr.* **74**, 4378, (2003).
  - [4] S. Jeon, Y. Braiman, and T. Thundat *Rev. Sci. Instr.* **75**, 4841, (2004).
  - [5] R. Piner and R. S. Ruoff, *Rev. Sci. Instr.* **73**, 3392, (2002).
  - [6] T. Jungk, A. Hoffmann, and E. Soergel *Appl. Phys. Lett.* to be published (2006).
  - [7] T. Jungk, et al to be published
  - [8] T. Jungk, A. Hoffmann, and E. Soergel *Appl. Phys. Lett.* **89**, 042901, (2006)