

Temperature dependent third cumulant of tunneling noise

C. W. J. Beenakker,¹ M. Kindermann,¹ and Yu. V. Nazarov²

¹*Instituut-Lorentz, Universiteit Leiden, P.O. Box 9506, 2300 RA Leiden, The Netherlands*

²*Department of Nanoscience, Delft University of Technology, Lorentzweg 1, 2628 CJ Delft, The Netherlands*
(Dated: January 2003)

Poisson statistics predicts that the shot noise in a tunnel junction has a temperature independent third cumulant $e^2\bar{I}$, determined solely by the mean current \bar{I} . Experimental data, however, show a puzzling temperature dependence. We demonstrate theoretically that the third cumulant becomes strongly temperature dependent and may even change sign as a result of feedback from the electromagnetic environment. In the limit of a noninvasive (zero-impedance) measurement circuit in thermal equilibrium with the junction, we find that the third cumulant crosses over from $e^2\bar{I}$ at low temperatures to $-e^2\bar{I}$ at high temperatures.

PACS numbers: 73.50.Td, 05.40.Ca, 72.70.+m, 74.40.+k

Shot noise of the electrical current was studied a century ago as a way to measure the fundamental unit of charge [1]. Today shot noise is used for this purpose in a wide range of contexts, including superconductivity and the fractional quantum Hall effect [2]. Already in the earliest work on vacuum tubes it was realized that thermal fluctuations of the current can mask the fluctuations due to the discreteness of the charge. In semiconductors, in particular, accurate measurements of shot noise are notoriously difficult because of the requirement to maintain a low temperature at a high applied voltage.

Until very recently, only the second cumulant of the fluctuating current was ever measured. The distribution of transferred charge is nearly Gaussian, because of the law of large numbers, so it is quite nontrivial to extract cumulants higher than the second. Much of the experimental effort was motivated by Levitov and Reznikov's prediction [3] that odd cumulants of the current through a tunnel junction should not be affected by the thermal noise that contaminates the even cumulants. This is a direct consequence of the Poisson statistics of tunneling events. The third cumulant should thus have the linear dependence on the applied voltage characteristic of shot noise, regardless of the ratio of voltage and temperature. In contrast, the second cumulant levels off at the thermal noise for low voltages.

The first experiments on the voltage dependence of the third cumulant of tunnel noise have now been reported [4]. The pictures are strikingly different from what was expected theoretically. The slope varies by an order of magnitude between low and high voltages, and for certain samples even changes sign. Such a behavior is expected for a diffusive conductor [5], but not for a tunnel junction. Although the data is still preliminary, it seems clear that an input of new physics is required for an understanding. It is the purpose of this paper to provide such input.

We will show that the third cumulant of the measured noise (unlike the second cumulant [6]) is affected by the measurement circuit in a nonlinear way. The effect can be seen as a backaction of the electromagnetic environment [7]. We have found that the backaction persists even in the limit of zero impedance, when the measure-

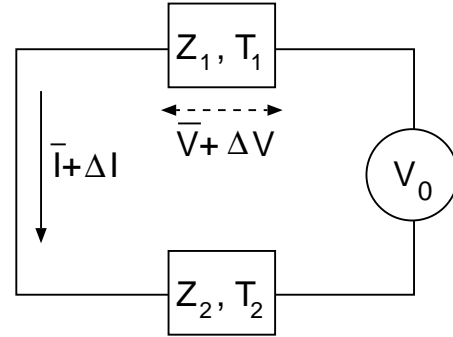

FIG. 1: Two resistors in series with a voltage source. The fluctuating current and voltage are indicated.

ment is supposed to be noninvasive. The temperature independent result for the third cumulant of tunneling noise is recovered only if the measurement circuit has both negligible impedance and negligible temperature.

The circuit is shown schematically in Fig. 1. Two resistors (impedances Z_1, Z_2 and temperatures T_1, T_2) are connected in series to a voltage source (voltage V_0). We will specialize later to the case that resistor 1 is a tunnel junction and that resistor 2 represents the macroscopic measurement circuit, but our main results hold for any two resistors. We disregard possible Coulomb blockade effects on fluctuations [8, 9, 10], which is justified if the impedances at frequencies of order eV/\hbar are small compared to \hbar/e^2 [11].

We have calculated the temperature dependence of the third cumulant by two altogether different methods, the Keldysh formalism [12] and the Langevin approach [13]. The equivalence of the two methods has already been demonstrated for a single resistor in the absence of any measurement circuit [5]. Likewise, we have obtained the same results in both calculations of the backaction from the measurement. We choose to present the Langevin approach in this paper, because it can be explained in elementary terms and provides an intuitive physical insight.

Starting point of the Langevin approach is the sep-

aration of the fluctuation ΔI_i of the current through resistor $i = 1, 2$ into an intrinsic fluctuation δI_i plus a term induced by a fluctuation ΔV_i of the voltage over the resistor: $\Delta I_i = \delta I_i + \Delta V_i/Z_i$. At low frequencies $\Delta I_1 = \Delta I_2 \equiv \Delta I$ and $\Delta V_1 = -\Delta V_2 \equiv \Delta V$. Upon substitution we arrive at the two equations

$$Z\Delta I = Z_1\delta I_1 + Z_2\delta I_2, \quad Z\Delta V = Z_1Z_2(\delta I_2 - \delta I_1), \quad (1)$$

where $Z = Z_1 + Z_2$ is the total impedance of the circuit.

For simplicity we assume that Z_i is real and frequency independent in the frequency range of the measurement. All formulas have a straightforward generalization to complex $Z_i(\omega)$. We do not need to assume at this stage that the current-voltage characteristic of the resistors is linear. If it is not, then one should simply replace $1/Z_i$ by the differential conductance evaluated at the mean voltage \bar{V}_i over the resistor.

The mean voltages are given by $\bar{V}_1 = (Z_1/Z)V_0 \equiv \bar{V}$ and $\bar{V}_2 = V_0 - \bar{V}$. The intrinsic current fluctuations δI_i are driven by the fluctuating voltage $V_i = \bar{V}_i + \Delta V_i$, and therefore depend in a nonlinear way on ΔV . The nonlinearity has the effect of mixing in lower order cumulants of δI_i in the calculation of the p -th cumulant of ΔI , starting from $p = 3$.

Before addressing the case $p = 3$ we first consider $p = 2$, when all averages $\langle \dots \rangle_{\bar{V}}$ can be performed at the mean voltage. At low frequencies one has

$$\langle \delta I_i(\omega)\delta I_i(\omega') \rangle_{\bar{V}} = 2\pi\delta(\omega + \omega')\mathcal{C}_i^{(2)}(\bar{V}_i). \quad (2)$$

The noise power $\mathcal{C}_i^{(2)}$ depends on the model for the resistor. We give two examples. In a macroscopic resistor the shot noise is suppressed by electron-phonon scattering and only thermal noise remains:

$$\mathcal{C}_i^{(2)} = 2kT_i/Z_i \quad (3)$$

at temperature T_i , independent of the voltage. (The noise power is a factor of two larger if positive and negative frequencies are identified.) In a tunnel junction both thermal noise and shot noise coexist, according to [2]

$$\mathcal{C}_i^{(2)}(\bar{V}_i) = (e\bar{V}_i/Z_i) \cotanh(e\bar{V}_i/2kT_i). \quad (4)$$

From Eq. (1) we compute the correlator

$$\langle \Delta X(\omega)\Delta Y(\omega') \rangle_{\bar{V}} = 2\pi\delta(\omega + \omega')S_{XY}(\bar{V}), \quad (5)$$

where X and Y can represent I or V . The result is

$$S_{II} = Z^{-2}[Z_1^2\mathcal{C}_1^{(2)}(\bar{V}) + Z_2^2\mathcal{C}_2^{(2)}(V_0 - \bar{V})], \quad (6a)$$

$$S_{VV} = Z^{-2}(Z_1Z_2)^2[\mathcal{C}_1^{(2)}(\bar{V}) + \mathcal{C}_2^{(2)}(V_0 - \bar{V})], \quad (6b)$$

$$S_{IV} = Z^{-2}Z_1Z_2[Z_2\mathcal{C}_2^{(2)}(V_0 - \bar{V}) - Z_1\mathcal{C}_1^{(2)}(\bar{V})]. \quad (6c)$$

Eq. (5) applies to a time independent mean voltage \bar{V} . For a time dependent perturbation $v(t)$ one has, to linear order,

$$\langle \Delta X(\omega)\Delta Y(\omega') \rangle_{\bar{V}+v} = \langle \Delta X(\omega)\Delta Y(\omega') \rangle_{\bar{V}} + v(\omega + \omega')\frac{d}{d\bar{V}}S_{XY}(\bar{V}). \quad (7)$$

We will use this equation, with $v = \Delta V$, to describe the effect of a fluctuating voltage over the resistors. This assumes a separation of time scales between ΔV and the intrinsic current fluctuations δI_i , so that we can first average over δI_i for given ΔV and then average over ΔV .

Turning now to the third cumulant, we first note that at fixed voltage the intrinsic current fluctuations δI_1 and δI_2 are uncorrelated, with third moment

$$\langle \delta I_i(\omega_1)\delta I_i(\omega_2)\delta I_i(\omega_3) \rangle_{\bar{V}} = 2\pi\delta(\omega_1 + \omega_2 + \omega_3)\mathcal{C}_i^{(3)}(\bar{V}_i). \quad (8)$$

The spectral density $\mathcal{C}_i^{(3)}$ vanishes for a macroscopic resistor. For a tunnel junction it has the temperature independent value [3]

$$\mathcal{C}_i^{(3)}(\bar{V}_i) = e^2\bar{V}_i/Z_i = e^2\bar{I}, \quad (9)$$

with \bar{I} the mean current.

We introduce the nonlinear feedback from the voltage fluctuations through the relation

$$\langle \Delta X_1\Delta X_2\Delta X_3 \rangle = \langle \Delta X_1\Delta X_2\Delta X_3 \rangle_{\bar{V}} + \sum_{\text{cyclic}} \langle \Delta X_j\Delta V(\omega_k + \omega_l) \rangle_{\bar{V}}\frac{d}{d\bar{V}}S_{X_kX_l}(\bar{V}). \quad (10)$$

The variable X_j stands for $I(\omega_j)$ or $V(\omega_j)$ and the sum is over the three cyclic permutations j, k, l of the indices 1, 2, 3. These three terms account for the fact that the same voltage fluctuation ΔV that affects $S_{X_kX_l}$ also correlates with X_j , resulting in a cross-correlation.

Eq. (10) has the same form as the ‘‘cascaded average’’ through which Nagaev introduced a nonlinear feedback into the Langevin equation [13]. In that work the nonlinearity appears because the Langevin source depends on the electron density, which is itself a fluctuating quantity — but on a slower time scale, so the averages can be carried out separately, or ‘‘cascaded’’. In our case the voltage drop ΔV_i over the resistors is the slow variable, relative to the intrinsic current fluctuations δI_i .

Eq. (10) determines the current and voltage correlators

$$\langle \Delta X(\omega_1)\Delta Y(\omega_2)\Delta Z(\omega_3) \rangle = 2\pi\delta(\omega_1 + \omega_2 + \omega_3)C_{XYZ}(\bar{V}). \quad (11)$$

We find

$$C_{III} = Z^{-3}[Z_1^3 C_1^{(3)}(\bar{V}) + Z_2^3 C_2^{(3)}(V_0 - \bar{V})] + 3S_{IV} \frac{d}{d\bar{V}} S_{II}, \quad (12a)$$

$$C_{VVV} = Z^{-3}(Z_1 Z_2)^3 [C_2^{(3)}(V_0 - \bar{V}) - C_1^{(3)}(\bar{V})] + 3S_{VV} \frac{d}{d\bar{V}} S_{VV}, \quad (12b)$$

$$C_{VVI} = Z^{-3}(Z_1 Z_2)^2 [Z_1 C_1^{(3)}(\bar{V}) + Z_2 C_2^{(3)}(V_0 - \bar{V})] + 2S_{VV} \frac{d}{d\bar{V}} S_{IV} + S_{IV} \frac{d}{d\bar{V}} S_{VV}, \quad (12c)$$

$$C_{IIV} = Z^{-3} Z_1 Z_2 [Z_2^2 C_2^{(3)}(V_0 - \bar{V}) - Z_1^2 C_1^{(3)}(\bar{V})] + 2S_{IV} \frac{d}{d\bar{V}} S_{IV} + S_{VV} \frac{d}{d\bar{V}} S_{II}. \quad (12d)$$

We apply the general result (12) to a tunnel barrier (resistor number 1) in series with a macroscopic resistor (number 2). The spectral densities $C_1^{(2)}$ and $C_1^{(3)}$ are given by Eqs. (4) and (9), respectively. For $C_2^{(2)}$ we use Eq. (3), while $C_2^{(3)} = 0$. From this point on we assume linear current-voltage characteristics, so \bar{V} -independent Z_i 's. We compare $C_I \equiv C_{III}$ with $C_V \equiv -C_{VVV}/Z_2^3$. The choice of C_V is motivated by the typical experimental situation in which one measures the current fluctuations indirectly through the voltage over a macroscopic series resistor. From Eq. (12) we find

$$C_x = \frac{e^2 \bar{I}}{(1 + Z_2/Z_1)^3} \left[1 + \frac{3(\sinh u \cosh u - u)}{(1 + Z_1/Z_2) \sinh^2 u} \times \left(\frac{T_2 g_x}{T_1 u} - \coth u \right) \right], \quad (13)$$

with $g_I = 1$, $g_V = -Z_1/Z_2$, and $u = e\bar{V}/2kT_1$.

In the shot noise limit ($e\bar{V} \gg kT_1$) we recover the third cumulant obtained in Ref. [7] by the Keldysh technique:

$$C_I = C_V = e^2 \bar{I} \frac{1 - 2Z_2/Z_1}{(1 + Z_2/Z_1)^4}. \quad (14)$$

In the opposite limit of small voltages ($e\bar{V} \ll kT_1$) we obtain

$$C_I = e^2 \bar{I} \frac{1 + (Z_2/Z_1)(2T_2/T_1 - 1)}{(1 + Z_2/Z_1)^4}, \quad (15)$$

$$C_V = e^2 \bar{I} \frac{1 - Z_2/Z_1 - 2T_2/T_1}{(1 + Z_2/Z_1)^4}. \quad (16)$$

We conclude that there is a change in the slope $dC_x/d\bar{I}$ from low to high voltages. If the entire system is in thermal equilibrium ($T_2 = T_1$), then the change in slope is a factor $\pm(Z_1 - 2Z_2)(Z_1 + Z_2)^{-1}$, where the + sign is for C_I and the - sign for C_V . In Fig. 2 we plot the entire voltage dependence of the third cumulants.

The limit $Z_2/Z_1 \rightarrow 0$ of a noninvasive measurement is of particular interest. Then $C_I = e^2 \bar{I}$ has the expected result for an isolated tunnel junction [3], but C_V remains affected by the measurement circuit:

$$\lim_{Z_2/Z_1 \rightarrow 0} C_V = e^2 \bar{I} \left(1 - \frac{T_2}{T_1} \frac{3(\sinh u \cosh u - u)}{u \sinh^2 u} \right). \quad (17)$$

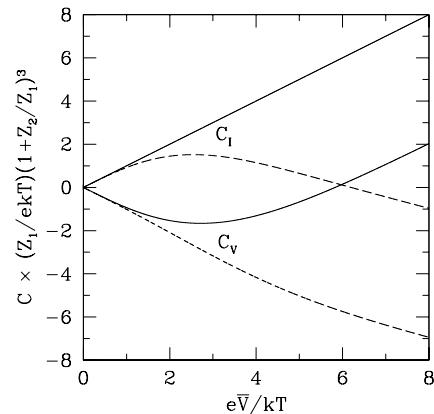

FIG. 2: Voltage dependence of the third cumulants C_I and C_V of current and voltage for a tunnel junction (resistance Z_1) in series with a macroscopic resistor Z_2 . The two solid curves are for $Z_2/Z_1 \rightarrow 0$ and the dashed curves for $Z_2/Z_1 = 1$. The curves are computed from Eq. (13) for $T_1 = T_2 \equiv T$. The high voltage slopes are the same for C_I and C_V , while the low voltage slopes have the opposite sign.

This limit is also plotted in Fig. 2, for the case $T_2 = T_1 \equiv T$ of thermal equilibrium between the tunnel junction and the macroscopic series resistor. The slope then changes from $dC_V/d\bar{I} = -e^2$ at low voltages to $dC_V/d\bar{I} = e^2$ at high voltages. The minimum $C_V = -1.7 e k T / Z_1 = -0.6 e^2 \bar{I}$ is reached at $e\bar{V} = 2.7 k T$.

In conclusion, we have demonstrated that feedback from the measurement circuit introduces a temperature dependence of the third cumulant of tunneling noise. The temperature independent result $e^2 \bar{I}$ of an isolated tunnel junction [3] acquires a striking temperature dependence in an electromagnetic environment, to the extent that the third cumulant may even change its sign. Precise predictions have been made for the dependence of the noise on the environmental impedance and temperature, which can be tested in ongoing experiments [4].

We gratefully acknowledge discussions with B. Reulet, which motivated us to write this paper. Our research is supported by the Dutch Science Foundation NWO/FOM.

-
- [1] W. Schottky, Ann. Phys. (Leipzig) **57**, 541 (1918); **68**, 157 (1922).
- [2] Ya. M. Blanter and M. Büttiker, Phys. Rep. **336**, 1 (2000).
- [3] L. S. Levitov and M. Reznikov, cond-mat/0111057.
- [4] Experimental data by B. Reulet, D. E. Prober, et al., presented at the International Workshop on “Electrons in Zero-Dimensional Conductors” (Max Planck Institute for the Physics of Complex Systems, Dresden, 2002).
- [5] D. B. Gutman and Y. Gefen, cond-mat/0201007.
- [6] U. Gavish, Y. Imry, Y. Levinson, and B. Yurke, cond-mat/0211646.
- [7] M. Kindermann, Yu. V. Nazarov, and C. W. J. Beenakker, cond-mat/0210617.
- [8] E. Ben-Jacob, E. Mottola, and G. Schön, Phys. Rev. Lett. **51**, 2064 (1983); G. Schön, Phys. Rev. B **32**, 4469 (1985).
- [9] H. Lee and L. S. Levitov, Phys. Rev. B **53**, 7383 (1996).
- [10] A. V. Galaktionov, D. S. Golubev, and A. D. Zaikin, cond-mat/0212494.
- [11] G.-L. Ingold and Yu. V. Nazarov, in *Single Charge Tunneling*, edited by H. Grabert and M. H. Devoret, NATO ASI Series B294 (Plenum, New York, 1992).
- [12] Yu. V. Nazarov, Ann. Phys. (Leipzig) **8**, 507 (1999); Yu. V. Nazarov and M. Kindermann, cond-mat/0107133.
- [13] K. E. Nagaev, Phys. Rev. B **66**, 075334 (2002); K. E. Nagaev, P. Samuelsson, and S. Pilgram, Phys. Rev. B **66**, 195318 (2002); S. Pilgram, A. N. Jordan, E. V. Sukhorukov, and M. Büttiker, cond-mat/0212446.
- [14] D. B. Gutman, Y. Gefen, and A. D. Mirlin, cond-mat/0210076.