

THEORY OF THE SPIN BATH

N. V. Prokof'ev^{1,2,3} and P. C. E. Stamp^{3,4}

¹ *Russian Science Centre "Kurchatov Institute", Moscow 123182, Russia*

² *Physics and Astronomy, Hasbrouck Laboratory, University of Massachusetts, Amherst, MA 01003, USA*

³ *Physics Department, and Canadian Institute for Advanced Research, University of British Columbia, 6224 Agricultural Rd., Vancouver B.C., Canada V6T 1Z1*

⁴ *Spinoza Institute, and Institute for Theoretical Physics, Minnaert Building, University of Utrecht, Leuvenlaan 4, 3508 TD Utrecht, the Netherlands.*

The quantum dynamics of mesoscopic or macroscopic systems is always complicated by their coupling to many "environmental" modes. At low T these environmental effects are dominated by *localised* modes, such as nuclear and paramagnetic spins, and defects (which also dominate the entropy and specific heat). This environment, at low energies, maps onto a "spin bath" model. This contrasts with "oscillator bath" models (originated by Feynman and Vernon) which describe *delocalised* environmental modes such as electrons, phonons, photons, magnons, etc. The couplings to N spin bath modes are *independent* of N (rather than the $\sim O(1/\sqrt{N})$ dependence typical of oscillator baths), and often strong. One cannot in general map a spin bath to an oscillator bath (or vice-versa); they constitute distinct "universality classes" of quantum environment.

We show how the mapping to spin bath models is made, and then discuss several examples in detail, including moving particles, magnetic solitons, nanomagnets, and SQUIDs, coupled to nuclear and paramagnetic spin environments.

We then focus on the "Central Spin" model, which couples a central 2-level system to a background spin bath. It is the spin bath analogue of the famous "spin-boson" oscillator model, and describes, eg., the tunneling dynamics of nanoscopic and mesoscopic magnets and superconductors. We show how to average over (or "integrate out") spin bath modes, using an operator instanton technique, to find the Central spin dynamics. The formal manoeuvres involve 4 separate averages- each average corresponds physically to a different "decoherence" mechanism acting on the central spin dynamics. Each environmental spin has its own topological "spin phase", which by interacting with the phase of the central system, decoheres it- this can happen even without dissipation. We give analytic results for the central spin correlation functions, under various conditions.

We then describe the application of this theory to magnetic and superconducting systems. Particular attention is given to recent work on tunneling magnetic macromolecules, where the role of the nuclear spin bath in controlling the tunneling is very clear; we also discuss other magnetic systems in the quantum regime, and the influence of nuclear and paramagnetic spins on flux dynamics in SQUIDs.

Finally, we discuss decoherence mechanisms and coherence experiments in superconductors and magnets. We show that a spin bath environment causes decoherence even in the $T \rightarrow 0$ limit. Control of this decoherence will be essential in the effort to construct "qubits" for quantum computers.

I. INTRODUCTION

Many problems in quantum physics can be discussed using a model in which one or more mesoscopic or even macroscopic coordinates Q, Q' , etc., interact with a background environment (one coordinate might also represent an experimental probe, or even an observer). In such models (which have a long history¹⁻³) all variables, including the environmental ones, are treated *quantum-mechanically*. The aim is to find the behaviour of Q, Q' , etc., after *averaging* over the environmental variables in some way.

It is certainly not obvious that one can discuss the real world in this way, given the complexity of N -body systems. However we now know that many (but not all) mesoscopic or macroscopic systems can be described *at low energies* by a few "canonical models", where a simple "central system" (eg., a 2-level system, or an oscillator) couples to an environment. Remarkably, there appear to be only two types of environment, describable as baths of either oscillators or spins. One way of trying to justify such models is the "renormalisation group" viewpoint⁴, which maintains that

most physical systems fall into a few "universality classes", each scaling to its own "fixed point" in the space of possible Hamiltonians. All systems in a given universality class use the same canonical Hamiltonian- the differences between different systems lying in the different values of the relevant couplings in this Hamiltonian.

Although this "hard RG" philosophy clearly fails in some cases, it is a useful starting point for the present article, in which the quantum environment is modelled by a "spin bath" (usually of 2-level systems, or "spin-1/2" systems). The finite Hilbert space of each bath spin makes the spin bath appropriate for describing the low energy dynamics of a set of *localised* environmental modes. We concentrate on one particular "central spin" model⁵⁻⁹ in which the central system itself reduces to a 2-level system; but we also discuss cases where the central system is a one-dimensional coordinate (a "particle") moving through a field of spins.

Another well-known set of canonical models describes the environment as a set of uncoupled oscillators- these include the "spin- boson" model^{10,11} and the "Caldeira-Leggett" model^{11,12}. The spin-boson model couples a central 2-level system to the oscillators, and is thus the analogue of the central spin model; and the Caldeira-Leggett model couples a tunneling particle to the oscillators. These oscillator models all derive from a scheme proposed by Feynman and Vernon¹³, to describe a central system coupled *weakly* to N environmental modes; as they showed, the mapping to an oscillator bath can only be made rigorously *if the coupling is weak*. Oscillator models are thus best adapted to N *delocalised* environmental modes (where the coupling is automatically $\sim 1/N^{1/2}$, and thus small for large N).

However, readers familiar with low-temperature physics will know that at low energies, the entropy and heat capacity of almost all real physical systems are dominated instead by *local* modes such as defects, impurity spins, and nuclear spins¹⁴. Typically these relax very slowly at low T because little phase space is available in their coupling to any delocalised modes (or to each other). However they often couple strongly to any mesoscopic or macroscopic collective coordinate, which then easily perturbs them. This coupling is of course *independent* of N .

Unfortunately, even though spin bath models have been studied sporadically for many years³, the results have often been misleading, either because they treat some weak-coupling limit (sometimes made^{15,16} by arbitrarily multiplying the coupling to each of the N bath spins by a factor $1/N$, for no good physical reason), or because they drop some of the important couplings to the bath spins, in order to solve the model. In the weak-coupling limit, spin bath models can be mapped to oscillator baths¹⁷⁻¹⁹ (in accordance with the original remarks of Feynman and Vernon¹³). However one is often nowhere near the weak-coupling limit, and the mapping to the oscillator bath then *fails* in general^{5,7,9,19}. This demands a new approach, which is the subject of this review.

It may be useful to mention *why* many physicists are interested in models of this kind. Here are some of the reasons:

(i) Very rapid progress in work on intrinsically quantum processes (interference, tunneling, etc.) occurring at the nanoscopic and mesoscopic scales²⁰⁻²⁵, plus speculations about the coming "nanotechnological revolution". Perhaps the most exciting idea in this area is that of making "quantum computers" using nanoscopic superconductors²⁶, semiconductors²⁷, or nanomagnets. Needless to say, the technological repercussions of this work will be enormous, provided the crucial problem of decoherence can be overcome.

(ii) Physicists need to understand the mechanisms of decoherence and quantum dissipation¹¹ in nature, and the crossover to (or "emergence" of) classical behaviour from quantum physics as either size, temperature T , external fields, or couplings to the environment are increased. These issues are not only relevant to quantum device design, but also to problems in quantum gravity, and to the infamous "quantum measurement" problem²⁸. The existence of low- T canonical models, going beyond the phenomenology of stochastic or master equations²⁹ to work with closed Hamiltonians, is invaluable here. Recent examples include the analysis of quantum spin glass relaxation³⁰, quantum relaxation in nanomagnets^{5,7,9,24,25,31-40} and tunneling superconductors^{12,22,41-45,47,46}, and the study of quantum chaotic systems, stochastic resonance⁴⁸ and dissipative tunneling in AC fields⁴⁹. Earlier such models have been used for decades to discuss relaxation in fields like quantum chemistry⁵⁰ or nuclear physics.

(iii) Both oscillator and spin bath models map to many important models in quantum field theory. Thus the "spin-boson" model mentioned above¹⁰ maps, for specific parameter values, to the Kondo model, the Thirring and Sine-Gordon models, and various other 2-dimensional field theories. Although similar mappings have yet to be exploited in great detail for the spin bath, they will obviously be very useful for, eg., lattice spin models.

Most work in these areas has used oscillator bath representations of the environment, with the tacit assumption that delocalised environmental modes dominate the physics. However, experiments on quantum nanomagnetic systems^{33,34,36-40}, on glasses⁵¹, and on mesoscopic conductors^{52,53}, as well as theoretical debate about the mechanisms of decoherence in nature, clearly require a more general point of view. In fact we shall see that spin baths behave very differently from oscillator baths. For example, the oft-discussed connection between dissipation and decoherence which exists for oscillator bath environments^{12,54} is absent here- one can even have decoherence with no dissipation at all⁵, because of the quantum phase associated with the spin bath dynamics.

Although the existence of a quantum phase associated with spin is obvious (it is a quantum variable), it was not until Haldane⁵⁵ and Berry⁵⁶ discussed its topological properties that physicists realised its practical importance, in terms of the path traced out on the spin sphere. Just as in the usual Aharonov-Bohm effect, the "flux" enclosed by a path (given here by ωS , where S is the spin and ω is the enclosed solid angle on the unit spin sphere) is equal to a

dynamical phase- but now these are both in *spin space*, not in real space. These ideas (and related experiments) were the centre of enormous interest in the mid-late 1980's, in almost all fields of physics (and were extensively reviewed then⁵⁷).

In this article we will be interested in the spin phase of the *environment*. We stress here that the environmental "spin" variables may not necessarily refer to real spins (they can describe defects, or other such "2 level systems"), but they will still have an associated dynamic topological phase, which can be described by an effective spin bath variable. The environmental spin phase interacts with the phase of the central system, causing phase decoherence in its dynamics^{5,6,17}. From the point of view of measurement theory, this environmental phase decoherence comes from a "phase measurement" made by the spin environment¹⁷, in a kind of "inverse Stern-Gerlach" setup (where the spins, instead of being measured, are themselves doing the measuring!). Such phase decoherence also arises from oscillator baths, in a rather different (and much less effective) way⁵⁸. In fact, the relevant phases involve both an adiabatic "Berry" term and a second term coming from transitions between different bath states (section 3.A). There are also other decoherence mechanisms associated with the bath spins, coming from both the temporal fluctuations of the bias on the central system caused by the spin bath (section 3.D), and from the precession of the spins in the spin bath (with their associated phase) *in between* transitions of the central system (section 3.C). Thus the question of how the bath spin dynamics influences the central system is not simply a question of looking at Berry phases.

Practical application of the theory to, eg., SQUIDs, or nanomagnets, or "qubits" (section 5), must include all mechanisms properly (section 3.E). The tactic adopted in this article is to focus on a "Central Spin" model⁵⁻⁹ (sections 3 and 4), in which the role of each term is exposed rather clearly; after this one sees how things generalise to other models. This model is directly relevant to qubits, and to the observation of mesoscopic or "macroscopic" quantum coherence- indeed we maintain that any practical design of such devices must involve the elimination, by one means or another, of *all* decoherence mechanisms from the relevant spin bath¹⁹.

We begin the article (section 2) by showing how both oscillator and spin bath models arise as the low-energy truncated versions of higher energy Hamiltonians. We give several examples, both magnetic and superconducting, to illustrate this. Then, in section 3 we explain how, mathematically, one averages over the spin bath variables to find the behaviour of the central system. This is done pedagogically- we use the example of the Central Spin model (and compare it with the spin-boson model). Various simple limits are introduced, and solved, before the general technique is given at the end of section 3. In Section 4 we give some results⁷ for the dynamics of the Central Spin model, in various regimes, to show how the physics is influenced by the spin bath; and we also show how the system reduces to the spin-boson system in the weak-coupling limit. For those readers interested in the mathematical details, these are sketched in 2 Appendices.

Finally, in section 5 we return to physical applications, particularly to quantum magnetic systems and superconductors. We then discuss decoherence, and show how this should persist even in the $T \rightarrow 0$ limit. We finish by discussing the important application of the Central Spin model to decoherence in qubits and in quantum computation.

II. THE LOW-ENERGY EFFECTIVE HAMILTONIAN

In studying the low-energy dynamics of a central quantum system coupled to an environment, we begin by "truncating out" the unwanted high-energy physics, to produce a low-energy effective Hamiltonian. This is of course a quite general technique in physics, and one way to approach it is illustrated in Fig.1. Typically one has a reasonably accurately known "high-energy" or "bare" Hamiltonian (or Lagrangian) for a quantum system, valid below some "ultraviolet" upper energy cut-off energy E_c , and having the form

$$\tilde{H}_{\text{Bare}}(E_c) = \tilde{H}_o(\tilde{P}, \tilde{Q}) + \tilde{H}_{\text{int}}(\tilde{P}, \tilde{Q}; \tilde{p}, \tilde{q}) + \tilde{H}_{\text{env}}(\tilde{p}, \tilde{q}) \quad (E < E_c), \quad (2.1)$$

where \tilde{Q} is an \tilde{M} -dimensional coordinate describing that part of the system we are interested in (with \tilde{P} the corresponding conjugate momentum), and (\tilde{p}, \tilde{q}) are \tilde{N} -dimensional coordinates describing all other degrees of freedom which may couple to (\tilde{P}, \tilde{Q}) . Conventionally one refers to (\tilde{p}, \tilde{q}) as environmental coordinates. \tilde{H}_{Bare} is of course a low-energy form of some other even higher-energy Hamiltonian, in a chain extending ultimately back to quarks, leptons, and perhaps strings.

If, however, one is only interested in physics below a much lower energy scale Ω_o , then the question is - can we find a new effective Hamiltonian, of form

$$H_{\text{eff}}(\Omega_o) = H_o(P, Q) + H_{\text{int}}(P, Q; p, q) + H_{\text{env}}(p, q) \quad (E < \Omega_o), \quad (2.2)$$

in the truncated Hilbert space of energies below Ω_o ? In this H_{eff} , P and Q are generalised m -dimensional coordinates of interest, and p, q are N -dimensional environmental coordinates coupled to them. Since we have truncated the total Hilbert space, we have in general that $M < \tilde{M}$ and $N < \tilde{N}$.

Why do we make this truncation (after all, its inevitable effect will be to generate new couplings between the low-energy modes)? Essentially because in many cases the truncation pushes the new H_{eff} towards some low-energy “fixed point” Hamiltonian; and many different physical systems may flow to the same fixed point. This allows us to speak of “universality classes” of quantum environment, and of a small number of “canonical” effective Hamiltonians. All physical systems in the same universality class will be described by the same form for H_{eff} , albeit with different values for the couplings. As one varies the UV cut-off Ω_o , the couplings change and any given system moves in the “coupling” or “effective Hamiltonian” space; but they all move towards the same fixed point (or fixed line, in some cases) as Ω_o is reduced. The various coupling terms in $H_{\text{eff}}(\Omega_o)$, simply parametrise the path it takes as $\Omega_o \rightarrow 0$ (Fig.1).

Explicit derivations of H_{eff} for particular systems are lengthy; see eg.^{13,19,22,25,54,46} for general discussions, ref.¹⁹ for comparison of spin and oscillator bath systems, and^{12,20,59,47,68,69,73} for specific examples. In this article we will go directly to the canonical models, giving some examples of each so that readers can see how the high-energy Hamiltonians are related to the models for some real systems. To warm up we recall the basic structure of the oscillator bath effective Hamiltonians, and then move on immediately to discuss various canonical models involving spin baths.

A. Oscillator Bath models

For models in the general “universality class” of oscillator bath environments, H_{eff} takes the form^{13,54}:

$$H_{\text{eff}}(\Omega_o) = H_o(P, Q) + \sum_{q=1}^N \left[F_q(P, Q)x_q + G_q(P, Q)p_q \right] + \frac{1}{2} \sum_{q=1}^N \left(\frac{p_q^2}{m_q} + m_q \omega_q^2 x_q^2 \right), \quad (2.3)$$

where the generalised bath coordinates (q_k, p_k) are now oscillator displacements x_q and momenta p_q ; these describe *delocalised* modes. The couplings $F_q(P, Q)$ and $G_q(P, Q)$ are $\sim O(N^{-1/2})$, so that in the “thermodynamic limit” $N \gg 1$, appropriate to a macroscopic environment of delocalised oscillators, these couplings are small^{12,13,54} (a number of studies have also shown how higher-order couplings can be absorbed into linear but T -dependent couplings⁶⁰). A special case of (2.3) is the Feynman-Vernon bilinear coupling form¹³:

$$H_{\text{eff}}(\Omega_o) = H_o(P, Q) + \sum_{q=1}^N c_q x_q Q + \frac{1}{2} \sum_{q=1}^N \left(\frac{p_q^2}{m_q} + m_q \omega_q^2 x_q^2 \right), \quad (2.4)$$

where the couplings $c_q \sim O(N^{-1/2})$ as well. In recent years great attention has been given to problems where $H_o(P, Q)$ describes a tunneling system (the “Caldeira-Leggett” model^{11,12}); there have also been extensive studies of an oscillator coupled to oscillators⁶¹, of free particles coupled to oscillators^{61,62} and of band particles coupled to oscillators^{11,63}.

Suppose now the potential $V(Q)$ has a 2-well form, with small oscillation frequencies $\sim \Omega_o$, and a “bias” energy difference between the two minima $< \Omega_o$. Then for energies $< \Omega_o$, one further truncates to the celebrated “spin-boson” model¹⁰:

$$H_{\text{SB}}(\Omega_o) = \Delta(\Phi_o)\hat{\tau}_x + \xi_H \hat{\tau}_z + \sum_{q=1}^N \left[c_q^{\parallel} \hat{\tau}_z + (c_q^{\perp} \hat{\tau}_- + h.c.) \right] x_q + \frac{1}{2} \sum_{q=1}^N \left(\frac{p_q^2}{m_q} + m_q \omega_q^2 x_q^2 \right), \quad (2.5)$$

where the two-level central system (with tunneling amplitude $\Delta(\Phi_o)$ and longitudinal bias ξ_H) is described by the Pauli matrix vector $\hat{\tau}$, coupled to background oscillators having energies $\omega_q < \Omega_o$. We have introduced a topological phase Φ_o for the central system, which depends in general on an external field; the simplest and best-known example is a form $\Delta(\Phi_o) = 2\Delta_o \cos \Phi_o$, arising from the interference between 2 paths of amplitude $\Delta_o e^{\pm i\Phi_o}$ in the motion of the central system. This kind of “Aharonov-Bohm” interference is well-known in superconductors (where the phase is just the superconducting order parameter phase), and in magnets (where it is the topological spin phase⁵⁵⁻⁵⁷). One can have a more complicated dependence of $\Delta(\Phi_o)$ on Φ_o (eg., using multiple SQUIDS, or a nanomagnet with m -fold rotation symmetry), but we will stick with the simple $2 \cos \Phi_o$ dependence in this article.

For consistency we must assume $\xi_H < \Omega_o$, otherwise higher levels will be involved. Typically c_q^{\perp} is dropped, because its effects are down on those of c_q^{\parallel} by a factor $\sim (\Delta_o/\Omega_o)^2$ in tunneling rates; but sometimes $c_q^{\parallel} = 0$ (for reasons of symmetry), and then c_q^{\perp} must be retained. The tunneling amplitude $\Delta_o \sim \Omega_o e^{-A_o}$, where A_o is the tunneling action.

The fame of the spin-boson model partly arises because many well-known problems in condensed matter physics can be mapped to it- this is a good example of the “universality” mentioned above. Because the effect of each oscillator on the central system (and vice-versa) is very small, it may be entirely incorporated in second-order perturbation theory (ie., to order $\sim (F_q^2/\omega_q), (G_q^2/\omega_q)$) for the general form (2.3), or to order $\sim (c_q^2/\omega_q)$ for the bilinear forms (2.4),(2.5). In the latter case this immediately encapsulates all environmental effects in the spectral function^{12,13}

$$J_\alpha(\omega) = \frac{\pi}{2} \sum_{q=1}^N \frac{|c_q^\alpha|^2}{m_q \omega_q} \delta(\omega - \omega_q), \quad (2.6)$$

where $\alpha = \perp, \parallel$. In general $J_\alpha(\omega)$ also depends on T , even in the low- ω limit^{9,24,54}. The case where $J_\alpha(\omega) \sim \omega$ is referred to as “Ohmic”¹². Because the $c_q^\alpha \sim N^{-1/2}$, the $J_\alpha(\omega)$ are independent of N and have the usual “response function” form.

B. Two examples of Spin-Boson systems

We give just 2 examples here of how a spin-boson model can arise, in the description of mesoscopic systems at low energies. Both truncations ignore the presence of spin bath modes (for which see sections 2.E and 2.F, where we return to these 2 examples).

(i) Nanomagnet coupled to phonons or electrons: The electronic spin dynamics of nanomagnets are often described by a “giant spin” Hamiltonian $H_o(\vec{S})$, describing a quantum rotator with spin quantum number $S = |\vec{S}| \gg 1$. This model^{64,65} assumes the individual electronic moments are locked together by strong exchange interactions J_{ij} into a monodomain giant spin, with $\vec{S} = \sum_j \vec{s}_j$ (summed over local moment sites). This only works¹⁹ below a UV cut-off energy E_c considerably less than J_{ij} . However we are interested in the quantum dynamics for energies $< \Omega_o$, where Ω_o is controlled mostly by the single-ion magnetic anisotropy; in real nanomagnets $\Omega_o \sim 0.1 - 10 K$.

Any real nanomagnet has couplings to a spin bath of nuclear and paramagnetic spins, and to oscillator baths of phonons and electrons, which we now describe.

The “high-energy” coupling between phonons and \vec{S} is described by terms like^{66,67}:

$$\mathcal{H}_2^\phi \sim \Omega_o U(\vec{S}) \left(\frac{m_e}{M_a} \right)^{1/4} \sum_{\vec{q}} \left(\frac{\omega_q}{\Theta_D} \right)^{1/2} [b_{\vec{q}} + b_{\vec{q}}^\dagger], \quad (2.7)$$

where m_e is the electron mass, M_a the mass of the molecule, and $\Theta_D \sim c_s a^{-1}$ is the Debye temperature (with a the relevant lattice spacing, and c_s the sound velocity). The interaction $U(\vec{S}) \sim S$ and dimensionless; a typical example is the non-diagonal term $(\hat{S}_x \hat{S}_z / S)$, which causes phonon emission or absorption with a change ± 1 in S_z (since $S_x = \frac{1}{2}(S_+ + S_-)$). One also has diagonal terms in which $S_z S_x$ is replaced by, eg. S_z^2 ; and there are also higher couplings to, eg. pairs of phonons.

Truncation to the “quantum regime”⁹ then gives the spin-boson model (2.5), with a dominant non-diagonal coupling $c_q^\perp \sim S \Omega_o |\vec{q}|^{1/2}$, coming from terms like (2.7). In the absence of external fields in Hamiltonian $H_o^{eff}(\vec{S})$, the diagonal coupling c_q^\parallel is actually *zero* (because of time-reversal symmetry). The Caldeira-Leggett spectral function for the system has the form $J_\perp(\omega) \sim S^2 (\Omega_o^2 / \rho c_s^5) \omega^3$ where $B_\perp \sim (S^2 \Omega_o^2 / \Theta_D)$; here ρ is the density of the medium supporting Debye phonons, and $\Theta_D^4 \sim \rho c_s^5$.

If now we couple *electrons* to the giant spin, it is the *diagonal* coupling which dominates⁹. The electronic coupling to \vec{S} depends on the type of magnetism. Some details have been worked out for Kondo interactions with conduction electrons- the coupling to \vec{S} is

$$H_{int}^{GK} = \frac{1}{2} \bar{J} \vec{S} \cdot \hat{\sigma}^{\alpha\beta} \sum_{\vec{k}\vec{q}} F_q c_{\vec{k}+\vec{q},\alpha}^+ c_{\vec{k},\beta} \quad (2.8)$$

where \bar{J} is the mean value of the Kondo couplings to each individual electronic spin in the nanomagnet, and $\vec{S} F_q = \int (d^3 r / V_o) \vec{s}(\vec{r}) e^{i\vec{q}\cdot\vec{r}}$ is a “form factor” integrating the localised electron spin density $\vec{s}(\vec{r})$ over the nanomagnetic volume V_o . At low energies the corresponding spin-boson model has an “Ohmic” diagonal spectral function $J_\parallel(\omega) = \pi \alpha_\kappa \omega$. The size of α_κ depends on how the electrons permeate the nanomagnet⁹; if they permeate freely, $\alpha_\kappa \sim g^2 S^4 / 3$,

where $g = \bar{J}N(0)$ is the mean dimensionless Kondo coupling, and $N(0)$ the Fermi surface density of states. Typically $g \sim 0.1$, so α_κ can be big.

(ii) **RF SQUID (Flux coupled to electrons)**: We briefly recall one well-known application of the spin-boson model, to an RF SQUID coupled to both normal electrons (in shunts, etc.), and Bogoliubov quasiparticles^{22,47,68,46}. The flux ϕ passing through a superconducting ring with a weak link moves in a multiwell potential, which can be adjusted so that the lowest 2 wells (each with small oscillation or "Josephson plasma" frequency $\Omega_o \sim 2\pi[E_J/\pi C]^{1/2}/\phi_o$, where E_J is the Josephson weak link coupling energy) are almost degenerate, and dominate the low-energy properties. The high-energy coupling between the flux and the electronic quasiparticles has the form^{47,68,46}

$$H_{int} = \{\cos(\pi\phi/\phi_o) \sum_q t_q U_q^S (a_q + a_q^\dagger) + i \sin(\pi\phi/\phi_o) \sum_q t_q U_q^A (a_q - a_q^\dagger)\} \quad (2.9)$$

where $q \equiv (\vec{k}, \vec{k}')$ labels oscillator states describing a quasiparticle pair $|\vec{k}\vec{k}'\rangle$ with energy $\omega_q = E_k + E_{k'}$, t_q is the relevant junction tunneling matrix element, $U_q^{S/A}$ the symmetric/antisymmetric BCS coherence factor, and ϕ_o is the flux quantum. Thus we have a coupling to both the momenta and coordinates of the oscillators, which can also be written as a coupling to 2 independent oscillator baths⁴⁷. The T -dependence of the coherence factors (coming from the BCS gap dependence) as well as the gap structure in their energy dependence, gives a complex structure in $J(\omega, T)$. The reduction to the spin-boson model is now trivial¹⁰, the minima in ϕ -space of the effective potential corresponding to the 2 eigenstates of $\hat{\tau}_z$.

C. Spin Bath Environments

Now suppose we have a high-energy Hamiltonian of form (2.1), but where the environmental coordinates (\tilde{p}, \tilde{q}) are a set of N spin-1/2 variables $\{\hat{\sigma}_k\}$, (i.e., two-level systems); and we assume the interspin couplings to be weak. Then, instead of (2.3), we have

$$H = H_o(P, Q) + H_{int}(P, Q; \{\hat{\sigma}\}) + H_{env}(\{\hat{\sigma}\}); \quad (2.10)$$

$$H_{int}(P, Q; \{\hat{\sigma}\}) = \sum_{k=1}^N \left[F_k^\parallel(P, Q) \hat{\sigma}_k^z + [F_k^\perp(P, Q) \hat{\sigma}_k^- + h.c.] \right]; \quad (2.11)$$

$$H_{env}(\{\hat{\sigma}\}) = \sum_{k=1}^N \tilde{h}_k \hat{\sigma}_k + \sum_{k=1}^N \sum_{k'=1}^N V_{kk'}^{\alpha\beta} \hat{\sigma}_k^\alpha \hat{\sigma}_{k'}^\beta, \quad (2.12)$$

for energy scales $E < E_c$. Thus we now have a central system coupled to a "spin bath", described by $H_{env}(\{\hat{\sigma}\})$ in (2.12). The couplings $F_k^\parallel(P, Q)$ and $F_k^\perp(P, Q)$, between the central system and the bath spins, are usually much greater than the interspin couplings $V_{kk'}^{\alpha\beta}$; this means that the dynamics of each spin is largely "slaved" to that of the central system.

Unlike oscillator baths (whose modes typically represent delocalised environmental degrees of freedom), the $\{\hat{\sigma}_k\}$ represent *localised* modes (whose weak spatial overlap explains why the $V_{kk'}^{\alpha\beta}$ are small). This fact underlies a crucial difference between oscillator and spin bath environments- the couplings $F_k^\parallel(P, Q)$ and $F_k^\perp(P, Q)$ are *independent of the number N of bath spins*. Thus the larger is N , the larger is the total effect of the spin bath on the central system- there is no strict thermodynamic limit in the system, and it is not meaningful to let $N \rightarrow \infty$. We emphasize also that we see no justification in general for spin bath models in which $F_k^\parallel, F_k^\perp \sim O(N^{-1/2})$, or even $\sim O(1/N)$ (although one can certainly invent artificial models of this kind). Thus, if we add more localised environmental modes to our environment, it is clear that the different modes are approximately independent (as they will be if quasi-localised), so that their individual couplings to the central system will be hardly affected, i.e., will depend only weakly on N .

There is nothing to stop generalisation of this model to include bath spins $\{\vec{I}_k\}$, with $I_k = |\vec{I}_k| > 1/2$; the $(2I_k + 1)$ states then represent the degrees of freedom of, eg., a defect, or a spin (again, localised). This introduces tensor (eg., quadrupolar) couplings to the bath spins^{69,70}, and thereby complicates the mathematics- but does not alter the basic physics. We will not discuss this here (for the relevant formalism, and its application to the *Fe-8* molecular nanomagnet, see refs.^{69,70}).

D. Particle moving through a spin bath

A particle moving through a spin bath is described by (2.10), in which P and Q describe the momentum and position of the moving particle. The diagonal term $F_k^{\parallel}(P, Q)$ is analogous to the "position" oscillator coupling $F_q(P, Q)$ in (2.3), and likewise $F_k^{\perp}(P, Q)$ corresponds to $G_q(P, Q)$. However both forms can be altered by canonical transformation, corresponding to a rotation between the different coordinates. The most common problems involve a diagonal coordinate coupling $F_k^{\parallel}(Q)$ and a non-diagonal momentum coupling $F_k^{\perp}(P)$. Then bath transitions (spin flips) are induced by the motion of the particle, whereas a stationary particle sees a "potential" $U(Q, \{\sigma_k^z(t)\}) = \sum_k F_k^{\parallel}(Q) \sigma_k^z(t)$, in general time-dependent.

A nice mesoscopic example of this is a large magnetic soliton coupled to background spins²⁰. In many realistic cases the most important such coupling will be to paramagnetic impurities, but here we consider the simpler case of a hyperfine coupling to a set $\{\hat{\sigma}\}$ of N spin-1/2 nuclear spins. In this case $V_{kk'}^{\alpha\beta}$ describes the extremely weak internuclear dipolar coupling; typically $|V_{kk'}^{\alpha\beta}| \leq 10^{-7} K$; and \vec{h}_k is any external field that might influence these nuclei.

The "high-energy" Hamiltonian for such a wall is usually determined as an integral over the magnetisation density $\mathbf{M}(\mathbf{r})$ and its spacetime gradients⁷¹. From this one eliminates the details of the wall profile altogether, to produce a "bare" Hamiltonian (ie., neglecting the environment) for the wall coordinate; in simple cases where the wall demagnetisation field keeps the wall almost flat, this gives^{24,72}

$$H_w = \frac{1}{2} M_w \dot{Q}^2 - V(Q) - 2 S_w \mu_B M_0 H_e Q \quad (2.13)$$

for a wall with centre of mass coordinate Q and surface area S_w . The "pinning potential" $V(Q) = V_0 \operatorname{sech}^2(Q/\lambda_w)$, provided the pinning centre is much smaller than the wall width λ_w . The term linear in Q comes from an external magnetic field \mathbf{H}_e .

What now of the environment? In the literature there is extensive discussion of the effects of magnons (ie., spin waves)^{24,72}, electrons⁷³, and phonons²⁰ on the wall dynamics- these are all oscillator baths. However at low T spin bath effects, coming from nuclear and paramagnetic spins, will completely dominate. Even in Ni (where only 1% of the nuclei have spins, with a tiny hyperfine coupling $\omega_0 = 28.35 \text{ MHz} \sim 1.4 \text{ mK}$), all real samples have an important concentration of paramagnetic spins (caused by Oxygen in the sample) as well as many defects. In rare earths, the hyperfine coupling $\omega_k \sim 1 - 10 \text{ GHz}$ ($0.05 - 0.5 \text{ K}$), and hyperfine effects alone are quite massive. Thus we must modify H_w above to

$$H = H_w + \sum_{k=1}^N \omega_k^{\alpha\beta} s_k^{\alpha} I_k^{\beta} + \sum_k \sum_{k'} V_{kk'}^{\alpha\beta} I_k^{\alpha} I_{k'}^{\beta} \quad (2.14)$$

in which the electronic spins \mathbf{s}_k couple locally to N nuclear spins \mathbf{I}_k at positions \mathbf{r}_k ($k = 1, 2, 3, \dots N$), via a hyperfine coupling $\omega_k^{\alpha\beta}$ (and also in general to paramagnetic spins). The internuclear coupling $|V_{kk'}^{\alpha\beta}| \sim 1 - 100 \text{ kHz}$ ($0.05 - 5 \mu\text{K}$), ie., $\ll \omega_k$, but it gives the spin bath its own dynamics.

To write the Hamiltonian in the form (2.11), we write the continuum magnetisation $\mathbf{M}(\mathbf{r}) = \mathbf{M}_o(\mathbf{r}) + \mathbf{m}(\mathbf{r})$, where $\mathbf{M}_o(\mathbf{r})$ is the slowly-varying part describing the wall profile and $\mathbf{m}(\mathbf{r})$ describes fluctuations around this. Then we rotate the spin quantisation axis to be locally parallel to $\mathbf{M}_o(\mathbf{r})$, and get²⁰

$$H = H_w + \sum_{k=1}^N \int \frac{d^3 r}{\gamma_g} \delta(\mathbf{r} - \mathbf{r}_k) \left[\omega_k^{\parallel} M_z(\mathbf{r}) I_k^z + \omega_k^{\perp} [m_x(\mathbf{r}) I_k^x + m_y(\mathbf{r}) I_k^y] \right] + \frac{1}{2} \sum_k \sum_{k'} V_{kk'}^{\alpha\beta} I_k^{\alpha} I_{k'}^{\beta} \quad (2.15)$$

displaying explicitly the longitudinal and transverse couplings. The "particle" moves through a slowly fluctuating "random walk" potential field $U_{\parallel}(Q)$ (coming from the sum over couplings ω_k^{\parallel} to randomly oriented spins). The transverse coupling (independent of Q but not of P) causes "spin flip" transitions in the spin bath when the wall moves, even if the bath is at $T = 0$.

One may also discuss problems in superconductors and normal metals involving nuclear and paramagnetic spins, and other "defects", which can also be mapped to the same model of a particle moving through a spin bath (sections 2.F, 5.B).

E. The Central Spin Model

Is there a low-energy effective Hamiltonian, analogous to the spin-boson model, in which a "central" 2-level system couples instead to a spin bath? The answer is yes, but the effective Hamiltonian does not look quite so simple as the spin-boson one. In the *absence* of any external field, the analogue of the spin-boson form in (2.5) for a spin bath is actually^{5,7-9,59}

$$H_{\text{CS}}(\Omega_o) = \left\{ 2\tilde{\Delta}\hat{\tau}_- \cos \left[\Phi - \sum_k \vec{V}_k \cdot \hat{\sigma}_k \right] + H.c. \right\} \\ + \hat{\tau}_z \sum_{k=1}^N \omega_k^{\parallel} \vec{l}_k \cdot \hat{\sigma}_k + \sum_{k=1}^N \omega_k^{\perp} \vec{m}_k \cdot \hat{\sigma}_k + \sum_{k=1}^N \sum_{k'=1}^N V_{kk'}^{\alpha\beta} \hat{\sigma}_k^{\alpha} \hat{\sigma}_{k'}^{\beta} . \quad (2.16)$$

where $\vec{\tau}$ describes the central spin, and the σ_k the spin bath degrees of freedom. This form is not the most general one- apart from dropping external field effects (for which see below) we have also restricted the central spin phase in a simple $\cos \Phi$ form (*cf.* Introduction). As discussed below, both $\tilde{\Delta}$ and Φ incorporate spin bath renormalisation effects. The factor of 2 in front of $\tilde{\Delta}$ is somewhat arbitrary (if the cosine is one, then the actual "tunnel splitting" coming from (2.16), in the absence of spin bath effects, will be $4\tilde{\Delta}$).

The basic form of (2.16) is actually fairly easy to understand. The extra phase in the first "non-diagonal" term (adding to Φ) comes from the topological phase of the bath spins as they make transitions⁵. There are also diagonal terms, and a weak interaction $V_{kk'}$ between the bath spins. This form assumes the diagonal couplings $\omega_k^{\parallel}, \omega_k^{\perp}$ are \ll the UV cutoff Ω_o , and that $V_{kk'} \ll \omega_k^{\parallel}, \omega_k^{\perp}$. The ratio $V_{kk'}/\tilde{\Delta}$ is arbitrary. In sections 4 and 5 we shall see there is a weak coupling limit to this model, in which it reduces to a spin-boson system.

Before this model was derived in this general form and then solved, a number of special cases had already been looked at³. In particular, Shimshoni and Gefen⁷⁴ included only the diagonal terms ω_k^{\parallel} and ω_k^{\perp} , and examined the results in weak coupling in the presence of an AC field (see also^{32,69,70}); they clearly recognised that the problem was different from an oscillator bath one.

Let us now discuss the different terms in (2.16), in the order they appear (*cf.* Fig. 2).

(i) *Non-Diagonal terms*: That an extra phase term should exist, coming from the spin bath, is obvious on general grounds (*cf.* Introduction). One can understand its algebraic form in the following way. Notice that H_{eff} in (2.16) operates on both the central spin *and* the spin bath; and the effect of a single giant spin transition on $\hat{\sigma}_k$ can always be written as a transition between initial and final nuclear states, in the form $|\chi_k^{fin}\rangle = \hat{T}_k |\chi_k^{in}\rangle$, where

$$\hat{T}_k = e^{-i \int d\tau H_{int}(\tau)} = e^{-[\delta_k + i(\vec{V}_k \cdot \hat{\sigma}_k + \phi_k)]} \quad (2.17)$$

The integral over H_{int} is only defined once we know the trajectory of the central system during the tunneling event. It is in this sense that we say⁵ that the instanton has become an "operator" in the space of the spin bath modes. Notice that in general the central spin phase Φ and splitting Δ are renormalised by the bath couplings^{5,7,8}:

$$\Phi = \Phi_o + \sum_k \phi_k , \quad \tilde{\Delta} = \Delta_o \exp\left\{-\sum_k \delta_k\right\} . \quad (2.18)$$

The $\{\phi_k\}$ are "Berry phase" terms coming from the bath spin dynamics during a central spin flip, and the $\{\delta_k\}$ come from high-frequency modifications of the original high-energy potential ("barrier fluctuations"). One can show that both ϕ_k and δ_k are $\sim O(\omega_k^2/\Omega_o^2)$, where ω_k is the larger of $\omega_k^{\parallel}, \omega_k^{\perp}$, and we will ignore these terms from now on.

Expanding out the cosine in (2.16) gives a series of terms like $\hat{\tau}_{\pm} \Gamma_{\alpha\beta\gamma\dots} \hat{\sigma}_{k_1}^{\alpha} \hat{\sigma}_{k_2}^{\beta} \hat{\sigma}_{k_3}^{\gamma} \dots$ in which the instanton flip of the central spin couples simultaneously to many *different* bath spins- a single central spin transition can cause multiple transitions in the bath (Fig. 2). Later we will introduce a parameter λ which measures the average number of bath spins flipping during each instanton.

(ii) *Diagonal terms*: These act *between* transitions of the central spin (Fig. 2), and are also easy to understand. Formally, one starts by considering the "initial" and "final" fields (*ie.*, before and after a transition of $\vec{\tau}$) acting on $\vec{\sigma}_k$. Calling these fields $\vec{\gamma}_k^{(1)}$ and $\vec{\gamma}_k^{(2)}$ respectively (Fig. 3), we define the *sum* and the *difference* terms as

$$\omega_k^{\parallel} \vec{l}_k = (\vec{\gamma}_k^{(1)} - \vec{\gamma}_k^{(2)})/2 \\ \omega_k^{\perp} \vec{m}_k = (\vec{\gamma}_k^{(1)} + \vec{\gamma}_k^{(2)})/2 . \quad (2.19)$$

where \vec{l}_k and \vec{m}_k are unit vectors. Then the truncated diagonal interaction takes the form

$$H_{eff}^D = \sum_{k=1}^N \left\{ \tilde{\gamma}_k^{(1)} \frac{1 + \hat{\tau}_z}{2} + \tilde{\gamma}_k^{(2)} \frac{1 - \hat{\tau}_z}{2} \right\} \cdot \hat{\sigma}_k \equiv \hat{\tau}_z \sum_{k=1}^N \omega_k^{\parallel} \vec{l}_k \cdot \hat{\sigma}_k + \sum_{k=1}^N \omega_k^{\perp} \vec{m}_k \cdot \hat{\sigma}_k, \quad (2.20)$$

i.e., one term which changes during a transition of the central system, and one which does not.

The longitudinal coupling $\hat{\tau}_z \sum \omega_k^{\parallel} \sigma_k^z$ determines the gross structure of the bath states in energy space: it also determines an "internal bias field" $\epsilon(\{\sigma_k^z\}) = \sum \omega_k^{\parallel} \sigma_k^z$ acting on τ_z . The 2 levels of bath spin σ_k^z are split by energy ω_k^{\parallel} , depending on whether σ_k^z is parallel or antiparallel to τ_z . The effect of this on the 2^N fold multiplet of bath states surrounding each central spin state is shown in Fig. 4. Suppose we classify these states by their "polarisation group"; all bath states whose total longitudinal polarisation $\sum \sigma_k^z = M$ are in polarisation group M . Since the ω_k^{\parallel} vary from one bath spin to another, states in polarisation group M are spread over an energy range $\tilde{\Gamma}_M$; and the entire manifold of states, comprising all polarisation groups, is spread over a larger energy range E_o . Let us define *normalised* densities of states $G_M(\epsilon)$ and $W(\epsilon)$ for these 2 distributions, so that

$$W(\epsilon) = (1/2^N) \sum_M C_N^{(N+M)/2} G_M(\epsilon) \quad (2.21)$$

where $C_n^m = n!/m!(n-m)!$. In almost any physical case one will have strongly overlapping polarisation groups, so that for all but very small values of N , or except in the extreme wings of the distributions, one has

$$G_M(\epsilon) \sim (2/\pi \tilde{\Gamma}_M^2)^{1/2} e^{-2\epsilon^2/\tilde{\Gamma}_M^2}. \quad (2.22)$$

$$W(\epsilon) \sim (2/\pi E_o^2)^{1/2} e^{-2\epsilon^2/E_o^2}. \quad (2.23)$$

The simplest case is where the ω_k^{\parallel} cluster around a single central value ω_o with variance

$$\delta\omega_o = \sqrt{\frac{1}{N} \sum_k (\omega_k^{\parallel} - \omega_o)^2} \quad (2.24)$$

For this case we define a parameter $\mu = N^{1/2} \delta\omega_o / \omega_o$, characterising the degree of polarisation group overlap; overlap is complete when $\mu > 1$. Then $\tilde{\Gamma}_M \sim 2N^{1/2} \delta\omega_o$ and $E_o = 2N^{1/2} \omega_o$ (so that $\tilde{\Gamma}_M/E_o \sim \delta\omega_o/\omega_o = N^{-1/2} \mu$). In the extremely unlikely case where $\mu \ll 1$, $W(\epsilon)$ can no longer be treated as Gaussian- however there is an intrinsic lower limit to the linewidth of each polarisation group set by the interspin interaction $V_{kk'}$. This "intrinsic linewidth" $\Gamma_o \sim N^{1/2} V_o$, where V_o is a typical value of $V_{kk'}$; in any physically realistic case this is usually enough by itself to cause complete overlap of all groups (the essentially non-interacting case where $\tilde{\Gamma} = 0$, i.e., $\omega_k = \omega_o$ for all bath spins, and $V_{kk'} = 0, \vec{V}_k = 0, \omega_k^{\perp} = 0$, was actually studied by Garg³¹).

The "transverse" couplings ω_k^{\perp} arise when the fields before/ after a transition, acting on the $\{\vec{\sigma}_k\}$, are not exactly parallel or antiparallel. This can happen in many ways, either because of external fields which couple to the bath spins, or because of a lack of symmetry in the underlying dynamics of the central system, or in its coupling to the bath modes. Thus they are non-zero in any realistic situation.

(iii) *Internal Spin Bath dynamics*: Finally, the interaction $V_{kk'}$ is usually so weak that it does not change under truncation. If this term is absent, the spin bath will have no "intrinsic" dynamics, and remains inert between transitions of $\vec{\tau}$. Thus even if small, $V_{kk'}$ is important, since it allows the bath state to evolve during these intervals. The most important effect of $V_{kk'}$ is that it allows the longitudinal bias field $\epsilon(\{\sigma_k^z\})$ to fluctuate in time, between and during transitions of $\vec{\tau}$. Notice, however, that with the Hamiltonian in the form (2.16), *only fluctuations within the same polarisation group are allowed*. In NMR language, only T_2 processes occur in the intrinsic dynamics of the spin bath- changes in M can only occur via the interaction with the central spin. This will only be true at low T - at higher T longitudinal relaxation (i.e., " T_1 processes", in NMR language) between different polarisation groups should be included in a realistic model. Such processes (which arise from the interaction of the spin bath modes with other environmental modes, or with thermally excited higher modes of the central system, above the UV cutoff energy Ω_o) are almost always very slow when $kT \ll \Omega_o$. On the other hand T_2 fluctuations will persist until $kT \ll \Gamma_o$; in the physical examples studied so far this means they persist down to μK temperatures or below. We will return briefly to this very low T regime at the end of the article (section 5.C).

External Field Effects: In general all of the parameters in (2.16) will depend on any external field \mathbf{H}_o , because it changes the high-energy dynamics of both central system and bath- however we can make low-field expansions and separate out the most important terms. Defining the "Zeeman" coupling energies Ω_{H_o} and $\omega_k^{H_o}$ of central and bath spins to this field, it is easy to see that under the conditions $\Omega_{H_o}/\Omega_o < 1$ and $\omega_k^{H_o}/\omega_k < 1$, the principal changes to (2.16) will be (i) the addition of an obvious longitudinal coupling $\xi_{H_o}\hat{\tau}_z$ to the central spin, and (ii) Qthe changes $\Phi_o \rightarrow \Phi_{H_o}$, $\vec{V}_k \rightarrow \vec{V}_k^{H_o}$, and $\vec{\omega}_k^\perp \equiv \omega_k^\perp \hat{m}_k \rightarrow \vec{\omega}_k^\perp(\mathbf{H}_o)$, where up to *linear order* in H_o one has

$$\begin{aligned}\Phi_{H_o} &= \Phi_o + \psi(H_o); & \psi &\sim 2\pi\Omega_{H_o}/\Omega_o \\ \vec{V}_k^{H_o} &= \vec{V}_k + \vec{v}_k(H_o); & |\vec{v}_k(H_o)|/|\vec{V}_k| &\sim \omega_k^{H_o}/\omega_k \\ \vec{\omega}_k^\perp(\mathbf{H}_o) &= \vec{\omega}_k^\perp + \mathbf{d}_k(\mathbf{H}_o); & |\mathbf{d}_k(\mathbf{H}_o)|/\omega_k^\perp &\sim \omega_k^{H_o}/\omega_k.\end{aligned}\tag{2.25}$$

Thus even at low fields one has an important change in all the topological phases in the problem, and also to the *transverse* diagonal coupling (which itself arises from internal fields). In general \mathbf{H}_0 will also change the interspin bath couplings $V_{kk'}$; in a way which depends on the specific details of the problem. In the next 2 sections we see how this works for both magnetic and superconducting systems.

F. Nanomagnet coupled to nuclear and paramagnetic spins

If we start from the "giant spin" model introduced above for a nanomagnet, then a simple isotropic contact hyperfine coupling to nuclear spins will lead to a Hamiltonian (for $E < E_c$) like:

$$H(\vec{S}; \{\hat{\sigma}\}) = H_o(\vec{S}) + \frac{1}{S} \sum_{k=1}^N \omega_k \vec{S} \cdot \hat{\sigma}_k + H_{\text{env}}(\{\hat{\sigma}\});\tag{2.26}$$

where $H_o(\vec{S})$ is the "giant spin" Hamiltonian, and $H_{\text{env}}(\{\hat{\sigma}\})$ is the same as in (2.12). The generalisation of this simple Hamiltonian to include dipolar hyperfine interactions, as well as to higher spin nuclei and to paramagnetic spins (with tensor and quadrupolar couplings) can be used if necessary^{69,70}. Here we will assume for simplicity that $|\vec{I}_k| = I = \frac{1}{2}$, and write $\vec{I}_k \rightarrow \sigma_k$, i.e. the nuclear spins will be described by spin- $\frac{1}{2}$ Pauli matrices. In fact in many cases even if $I \neq \frac{1}{2}$, the low-energy nuclear spin dynamics is well described by a 2-level system.

The truncation of $H(\vec{S}; \{\hat{\sigma}\})$ to a central spin Hamiltonian $H_{\text{eff}}(\vec{\tau}; \{\hat{\sigma}\})$ has been discussed in several papers^{5,7,9,19,59,75}. As an example we quote the result for a simple easy axis-easy plane nanomagnet (for which $H_o(\vec{S}) = (1/S)[-K_2^\parallel \hat{S}_z^2 + K_2^\perp \hat{S}_y^2]$, and give it a physical interpretation. In this case, assuming $\omega_k \ll \Omega_o$ and also a weak external field \mathbf{H}_o , the effective Hamiltonian is^{5,7,9,59}:

$$\begin{aligned}H_{\text{eff}}(\Omega_o) &= \left\{ 2\Delta_o \hat{\tau}_- \cos \left[\pi S - i \sum_k \alpha_k \vec{n}_k \cdot \hat{\sigma}_k - \beta_o \mathbf{n}_o \cdot \mathbf{H}_o \right] + H.c. \right\} \\ &+ \hat{\tau}_z \left[\xi_H + \sum_{k=1}^N \omega_k^\parallel \hat{\sigma}_k^z \right] + \sum_{k=1}^N \sum_{k'=1}^N V_{kk'}^{\alpha\beta} \hat{\sigma}_k^\alpha \hat{\sigma}_{k'}^\beta.\end{aligned}\tag{2.27}$$

ie., a special case of the general form (2.16), with the parameters $\xi_H = g\mu_B S_z H_o^z$, $\vec{l}_k = \hat{z}$, $\omega_k^\parallel = \omega_k$, and $\omega_k^\perp = 0$. The vectors $\alpha_k \vec{n}_k$ and $\beta_o \mathbf{n}_o$ for this easy axis-easy plane case turn out to be (again assuming $\omega_k \ll \Omega_o$, and small \mathbf{H}_o):

$$\alpha_k \vec{n}_k = \frac{\pi\omega_k}{\Omega_o} (\hat{x}, i\sqrt{K_\parallel/K_\perp} \hat{y}); \quad \beta_o \mathbf{n}_o = \frac{\pi g\mu_B S}{\Omega_o} (\hat{x}, i\sqrt{K_\parallel/K_\perp} \hat{y})\tag{2.28}$$

In this example there are 2 tunneling trajectories (clockwise and counterclockwise in the easy plane), giving a result $e^{\pm i\alpha_k \vec{n}_k \cdot \vec{\sigma}_k}$ for the "transfer matrix" \hat{T}_k (in zero applied field). The resulting vector $\alpha_k \vec{n}_k$ is the "average hyperfine field" acting on $\vec{\sigma}_k$ during the tunneling event. To understand its orientation (and why it is *complex*) we note that the nuclear spin itself exercises a torque on \vec{S} while it is tunneling, and this pushes \vec{S} away from the easy plane. Consequently (a) the average field acting on $\vec{\sigma}_k$ has a component out of the easy plane, in the y -direction, and (b) \vec{S} no longer moves exactly along the easy-plane path, while tunneling, that it would in the absence of $\vec{\sigma}_k$ (and so its action increases, via the imaginary part of $\alpha_k \vec{n}_k$).

The contribution $\beta_o \mathbf{n}_o \cdot \mathbf{H}_o$ to the topological phase^{59,76,77} comes from the area swept out by the giant spin on the spin sphere (cf. Introduction), which changes as the field \mathbf{H}_o changes; it is essentially an "Aharonov-Bohm" contribution to this phase from the external field⁷⁶, which leads to spectacular oscillations (Fig. 5) in the effective tunneling amplitude $\hat{\Delta} \equiv 2\Delta_o \cos[\pi S + i\beta_o \mathbf{n}_o \cdot \mathbf{H}_o]$ for a field perpendicular to \hat{z} ^{70,77}. Very recently oscillations in the tunneling amplitude of *Fe-8* magnetic molecular crystals were seen which are related to this³⁹, although the presence of both nuclear spins and dipolar fields seriously complicates their interpretation⁷⁰ (see section 5.A).

We recall from section II.B that the giant spin model truncates for nanomagnets to a 2-level system for energies $\ll \Omega_o \sim 1 - 10 K$. Contact hyperfine couplings are in the range $1.3 - 30 mK$ (transition metals) or $40 - 500 mK$ (rare earths); on the other hand the internuclear couplings $V_{kk'} \sim 10^{-8} - 10^{-5} K$. In the *Fe-8* system just mentioned the hyperfine interactions are actually dominated by dipolar couplings between the 8 *Fe*⁺³ ions and the 120 protons in the molecule; these couplings are in the range $\sim 1 - 100 MHz$ ($0.05 - 5 mK$). When the hyperfine couplings are this weak we must also take into account the effect of external fields on the nuclear dynamics⁷⁰ (section 5.A). The values of Δ vary over a huge range, but typically $\Delta \ll \omega_k$ (in *Fe-8*, $\Delta \sim 10^{-7} K$).

G. SQUID coupled to nuclear and paramagnetic spins

We consider again the RF SQUID, but now concentrate on the coupling of the flux Φ to the spin bath of nuclear and paramagnetic spins which are within a penetration depth of the surface of the superconductor. This example is very instructive in understanding the weak-coupling limit of the central spin model (the following discussion is based on refs.^{19,78}).

Suppose to start with we consider a "cubic geometry"¹⁹, in which a cube of side $L = 1 cm$ has a hole of radius $R = 0.2 cm$ through it, with in addition a slit connecting the hole to the exterior, spanned by a cylindrical junction of length $l = 10^{-4} cm$ and diameter $d = 2 \times 10^{-5} cm$. The magnetic field inside the hole corresponding to a half-flux quantum is $B_o = (\pi \hbar c / e \pi R^2) = 2 \times 10^{-6} G$, whereas the magnetic field in the junction is as high as $B_j \sim B_o L / d = 10^{-1} G$.

There are both nuclear spins and paramagnetic impurities in the spin bath. Consider first the nuclear spins; assuming all nuclei have spins, we find that in the bulk of the ring, within a penetration depth of the surface, there are $N_r \sim 2\pi R \lambda_L L \times 10^{23} \approx 5 \times 10^{17}$ nuclear spins coupling to the ring current; and in the junction itself, a number more like $N_j = (\pi d l \lambda_L) \times 10^{23} \approx 3 \times 10^9$. Thus each ring nuclear spin couples to the SQUID with a diagonal coupling $\omega_r^\parallel \sim \mu_n B_o \sim 2 \times 10^{-13} K$; on the other hand for junction spins this coupling is $\omega_j^\parallel = \mu_n B_j \sim 10^{-8} K$. Notice we have ignored any coupling to substrate spins (assume, eg., the ring is in superfluid He-4!), which might have a much larger coupling to the current.

At any temperature such that $kT \gg \omega_r^\parallel, \omega_j^\parallel$, the typical polarisation of these spin baths will be $\sqrt{N_r}, \sqrt{N_j}$ respectively, giving a distribution of longitudinal bias energies with typical values $E_o^j \sim \omega_j^\parallel \sqrt{N_j} \approx 5 \times 10^{-4} K$, and $E_o^r \sim \omega_r^\parallel \sqrt{N_r} \approx 10^{-4} K$ acting on the tunneling flux coordinate Φ . If we now add paramagnetic impurities to the ring, with concentration n_{pm} , and coupling $\omega_{pm}^\parallel \sim 2 \times 10^3 \omega_r \sim 4 \times 10^{-10} K$ to the current, this gives a typical longitudinal bias energy $E_o^{pm} \sim n_{pm}^{1/2} \times 0.2 K$. This longitudinal term is obviously bigger than the nuclear contribution, unless the superconductor is very pure indeed!

However, there is another much stronger transverse term, because each spin feels the dipolar fields from the other spins. This field is $\geq 1G$ (much higher near to the paramagnetic spins), and for the nuclear spins has an associated energy $\omega_k^\perp \geq 10^{-7} K$, which is $\gg \omega_r^\parallel, \omega_j^\parallel$. Physically, when the SQUID flips, the field on each nuclear spin hardly changes its direction, being dominated by the more slowly varying (but much stronger) nuclear dipolar field. For the paramagnetic spins the analogous coupling ω_{pm}^\perp is $> 10^3$ times larger, which in the absence of nuclear fields would give an inter-paramagnetic "flip-flop" rate $V_{kk'}^{pm} \sim 10^9 n_{pm} Hz$, except that in pure samples these processes will themselves be blocked by the local dipolar coupling between the impurity and nearby nuclear spins (of strength $\omega_{pm}^\perp \sim 10^{-4} K$); this will happen once $n_{pm} \ll 10^{-3}$.

We can write down an effective Hamiltonian for this system, valid over timescales considerably greater than Δ^{-1} ; we will use this later to analyse the effect of the spins on the SQUID dynamics (section 5.B). We will assume that $\Delta \gg V_{kk'}$ (the only case of experimental interest); then we can treat the internuclear dipolar fields as slowly-varying in time. The effective Hamiltonian can then be derived, to give⁷⁸:

$$H_{\text{eff}}(\Omega_o) = \{ \Delta_o(\Phi_o) \hat{\tau}_+ e^{-i \sum_k \bar{\alpha}_k \cdot \hat{\sigma}_k} + H.c. \} + \xi_H \hat{\tau}_z + \sum_{k=1}^N [\hat{\tau}_z \omega_k^\parallel \hat{\sigma}_k^z + \omega_k^\perp \hat{\sigma}_k^x] \quad (2.29)$$

where $\omega_k^\parallel = \omega_r, \omega_j$ or ω_{pm} , depending on the spin, and ω_k^\perp has just been discussed; and microscopic analysis shows that $|\vec{\alpha}_k| \sim \omega_k^\parallel/\Omega_o$, where Ω_o is the Josephson plasma frequency (section 2.B). Notice that $\omega_k^\parallel/\omega_k^\perp \ll 1$, which is the opposite limit considered to that for the giant spin! Notice further that these couplings are far less than Δ_o ($E_o^r, E_o^j, E_o^{pm} \gg \Delta_o$ only because there are so many spins involved). Thus the spin bath is no longer "slaved" to the central system. In section 4 we see how this allows a mapping to an oscillator bath, coupled to $\vec{\tau}$ (ie., a spin-boson model).

Finally we note that the external field also acts on the nuclear and paramagnetic spin dynamics, via the Zeeman coupling (which simply adds to ω_k^\parallel). This can help to suppress decoherence effects, by freezing out the spin bath dynamics- for more details see ref.⁷⁸.

H. General Canonical Models

We now recall our assertion that almost any mesoscopic "central" system, coupled to its environment, may be described at low energies by (2.2), with the environment being written as a sum of an oscillator bath term (2.3) and a spin bath term ((2.12), or a higher spin generalisation). The simplest example is of a single central spin coupled to both oscillator and spin baths. Such a model seems forbidding but in fact a fairly complete analysis has been given of its dynamics⁹- we recall some of the results at the end of section 4. One can also consider a much more complicated model in which a *macroscopic array* of central spins $\{\vec{\tau}_j\}$, at positions $\{\mathbf{r}_j\}$, couples to both oscillator and spin baths. The effective Hamiltonian is then an obvious generalisation of what has gone before:

$$\begin{aligned}
H_{CS}(\Omega_o) = & \sum_j \left\{ \Delta_j \hat{\tau}_j^- \cos \left[\Phi_j - i \sum_k \alpha_{jk} \vec{n}_{jk} \cdot \hat{\sigma}_k \right] + H.c. \right\} + \sum_{i < j} V(\mathbf{r}_i - \mathbf{r}_j) \hat{\tau}_i^z \hat{\tau}_j^z \\
& + \sum_j \left\{ \hat{\tau}_j^z \sum_{k=1}^N \omega_{jk}^\parallel \vec{l}_{jk} \cdot \hat{\sigma}_k + \sum_{k=1}^N \omega_{jk}^\perp \vec{m}_{jk} \cdot \hat{\sigma}_k \right\} + \sum_{k=1}^N \sum_{k'=1}^N V_{kk'}^{\alpha\beta} \hat{\sigma}_k^\alpha \hat{\sigma}_{k'}^\beta \\
& + \sum_j \sum_q \left[c_{jq}^\parallel \hat{\tau}_j^z + (c_{jq}^\perp \hat{\tau}_j^- + h.c.) \right] x_q + \frac{1}{2} \sum_q \left(\frac{p_q^2}{m_q} + m_q \omega_q^2 x_q^2 \right) , \tag{2.30}
\end{aligned}$$

where $V(\mathbf{r}_i - \mathbf{r}_j) \hat{\tau}_i^z \hat{\tau}_j^z$ is a "high-energy" diagonal coupling between the various "central spin" systems. If we throw away the spin bath we get a set of 2-level systems coupling to an oscillator bath, of which the simplest example is the "PISCES" model (in which there are only two 2-level systems^{79,80}).

Such models seem impossibly complicated, but actually one can solve for their dynamics in many important regimes! What is crucial is the *separation* of the 2 baths. Often (as with nuclear spins) their mutual interaction is very weak (and can be parametrised by a time $T_1(T)$ which may be very long at low T); in this case this separation is a good one. If there *are* certain spin bath modes that interact strongly with the oscillators, then typically we can simply absorb these modes into an "augmented" oscillator bath by a canonical transformation. An obvious example arises with electronic spins in a metallic host (the Kondo or Kondo lattice problems); one rewrites the bath to include the "Kondo resonance" in the oscillator bath spectrum.

A proof that one may do this in all cases seems rather difficult- in any case the usefulness of these models tends to be established by their application. Models like (2.30) describe mesoscopic systems like coupled SQUIDS or coupled nanomagnets^{35,79,80}, Quantum Spin Glasses³⁰ and low- T dipolar glasses⁸¹, as well as coupled anisotropic coupled Kondo spins and Kondo lattices, coupled nuclear spin systems⁸², superconducting arrays, or coupled defects in solids. They are also useful for analysing purely theoretical questions about relaxation, dissipation, decoherence and quantum measurements in quantum systems- many questions remain unanswered, having only been studied thoroughly in restricted models such as the spin-boson model^{10,11} or the PISCES model^{79,80}. We return to experimental and theoretical applications in section 5.

III. AVERAGING OVER THE SPIN BATH

To extract useful information from the low-energy canonical models, we must calculate their dynamical properties. Since we are typically not interested in the environment (one usually has little control over it), one performs a statistical average over the environment. This procedure is fraught with danger, because of "memory" effects in the environment, and because assumptions such as "self-averaging" in the environmental correlation functions may not strictly be valid.

In this section we show how the spin bath may be "integrated out" by means of 4 different statistical averages, each involving an integration over a particular variable. The end result is a description of the time evolution of the "reduced" density matrix for the central system- *provided* we can ignore memory effects in the environment. The starting point is no different from that involved in functional averaging over oscillators¹¹⁻¹³; both begin with a path integral form for the propagator of the reduced central system density matrix, written as

$$K(1,2) = \int_{Q_1}^{Q_2} dQ \int_{Q'_1}^{Q'_2} dQ' e^{-i/\hbar(S_o[Q] - S_o[Q'])} \mathcal{F}[Q, Q'], \quad (3.1)$$

where $S_o[Q]$ is the free central system action, and $\mathcal{F}[Q, Q']$ is the famous "influence functional"¹³, defined in general by

$$\mathcal{F}[Q, Q'] = \prod_k \langle \hat{U}_k(Q, t) \hat{U}_k^\dagger(Q', t) \rangle, \quad (3.2)$$

Here the unitary operator $\hat{U}_k(Q, t)$ describes the evolution of the k -th environmental mode, given that the central system follows the path $Q(t)$ on its "outward" voyage, and $Q'(t)$ on its "return" voyage; and $\mathcal{F}[Q, Q']$ acts as a weighting function, over different possible paths ($Q(t), Q'(t)$).

For a central 2-level system, the paths $Q(t), Q'(t)$ are simple (recall Fig. 2):

$$Q_{(n)}(s) = 1 - \sum_{i=1}^{2n} [\text{sgn}(s - t_{2i-1}) + \text{sgn}(t_{2i} - s)], \quad (3.3)$$

where $\text{sgn}(x)$ is the sign-function, and n is the number of transitions of the central system, occurring at times t_1, t_2, \dots, t_{2n} (for definiteness we assume trajectories starting and ending in the same state, and use the convention that $Q = \pm 1$ corresponds to $\tau_z = \pm 1$). The goal is to find the central spin density matrix; in this article we give results for the "return probability" $P_{11}(t)$ for the system to be in the same state $|\uparrow\rangle$ at time t as it was at $t = 0$. Using (3.3) this can be written as an "instanton expansion" over flips of the central spin (Appendix A):

$$P_{11}(t) = \sum_{nm} (i\Delta_o)^{2(n+m)} \int_0^t dt_1 \dots \int_{t_{2n-1}}^{t_{2n}} dt_{2n} \int_0^{t_1} dt'_1 \dots \int_{t'_{2m-1}}^{t'} dt'_{2m} \mathcal{F}[Q_{(n)}, Q_{(m)}'] \quad (3.4)$$

Further simplification arises if the environmental modes are uncoupled- then $\mathcal{F}[Q, Q']$ factorises, and we can write $\mathcal{F}[Q, Q'] = \exp(-i\Phi[Q, Q']) = \exp(-i \sum_{k=1}^N \phi_k[Q, Q'])$, where the *complex* phase $\phi_k[Q, Q']$ contains both real (reactive), and imaginary (damping) contributions.

Now for an *oscillator bath* one simplifying feature is crucial, viz., the very weak coupling to each oscillator. This allows one to evaluate each $\phi_k[Q, Q']$ up to 2nd order only in these couplings, in terms of a spectral function for the *unperturbed* oscillator dynamics (compare $J(\omega, T)$ in (2.6)). Even though the paths $Q(t)$ and $Q'(t)$ may be complicated, the calculation of $\mathcal{F}[Q, Q']$ is often tractable¹¹.

However because the coupling to each spin bath mode is *not* necessarily weak, it will in general strongly alter their dynamics, often *slaving* them to the motion of the central system. *Thus we cannot start from the unperturbed spin bath dynamics*- the problem is fundamentally non-perturbative in the $\{\omega_k\}$. However it is not intractable, because one *can* rather easily deal with the dominant longitudinal terms $\{\omega_k^{\parallel}\}$. The other terms can then be dealt with perturbatively (and sometimes even non-perturbatively). It is the separation of the effects of the various terms in the Hamiltonian which leads to not one, but 4 different averages. What is quite remarkable is that these averages can be evaluated analytically in most cases (section 4).

We begin by explaining the 4 different averaging integrals required for a general spin bath. This is done pedagogically, by solving for 4 different limiting cases of the central spin Hamiltonian (sections III.A-III.D), each of which requires only one of the 4 averaging integrals. Then the general procedure (combining the 4 averages) is given in III.E. One reason for going through these averages one by one is that each corresponds to a different physical mechanism of decoherence- we return to this in section 5 (note that more detailed results for the 3 limiting cases discussed in sections III.B-III.D are given in refs.^{7,8}).

A. Phase averaging: Topological decoherence

Formally the case of pure topological decoherence applies to the following special case of H_{eff} , in which only non-diagonal terms are included:

$$H_{\text{eff}}^{\text{top}} = 2\Delta_o \left\{ \hat{\tau}_- \cos \left[\Phi_o - i \sum_{k=1}^N \alpha_k \vec{n}_k \cdot \hat{\sigma}_k \right] + H.c. \right\}, \quad (3.5)$$

Since $\omega_k^{\parallel} = \omega_k^{\perp} = 0$ are zero, *all* the 2^N environmental states are degenerate, and there is no exchange of any energy between $\vec{\tau}$ and the $\{\hat{\sigma}_k\}$. The only thing that is exchanged is *phase*; the phase Φ_o of $\vec{\tau}$ becomes entangled with that of the $\{\hat{\sigma}_k\}$, during the transitions of $\vec{\tau}$ between $|\uparrow\rangle$ and $|\downarrow\rangle$, so that the initial and final *states* of the spin environment are different. Physically (3.5) would arise if the original high-energy Hamiltonian contained only "transverse" couplings (to $\{\hat{\sigma}_k^{\pm}\}$), which only act while the central system is making transitions (in the case of a moving particle coupled to a spin bath, they would be "velocity couplings", only acting when the particle is moving).

We wish to determine $P_{11}(t)$ for this case. For pedagogical purposes let us begin by assuming that $-i\alpha_k$ is *real*, i.e., α_k is pure imaginary; then we have added a pure environmental phase term to the free 2-level Hamiltonian. Then, writing $-i\alpha_k \rightarrow \tilde{\alpha}_k$, the formal solution to this problem can be written immediately as⁵

$$P_{11}(t) = \frac{1}{2} \left\{ 1 + \langle \cos [4\Delta_o t \cos (\Phi_o + \sum_{k=1}^N \tilde{\alpha}_k \vec{n}_k \cdot \hat{\sigma}_k)] \rangle \right\}, \quad (3.6)$$

where the brackets $\langle \dots \rangle$ trace over the spin bath. By writing this as an instanton expansion over central spin flips (see App. A and refs.^{5,8}), we transform it to a *weighted integration over topological phase*:

$$P_{11}(t) = \sum_{m=-\infty}^{\infty} F(m) \int_0^{2\pi} \frac{d\varphi}{2\pi} e^{i2m(\Phi-\varphi)} \left\{ \frac{1}{2} + \frac{1}{2} \cos(2\Delta_o(\varphi)t) \right\} \quad (3.7)$$

$$= \frac{1}{2} \left\{ 1 + \sum_{m=-\infty}^{\infty} (-1)^m F(m) e^{i2m\Phi} J_{2m}(4\Delta_o t) \right\}, \quad (3.8)$$

where $\Delta_o(\varphi) = 2\tilde{\Delta}_o \cos \varphi$ is a *phase-dependent* tunneling amplitude, $J_{2m}(z)$ is a Bessel function, and

$$F(m) = \langle \prod_{k=1}^N e^{2im\tilde{\alpha}_k \vec{n}_k \cdot \hat{\sigma}_k} \rangle = \prod_{k=1}^N \cos(2m\tilde{\alpha}_k). \quad (3.9)$$

For small α_k we may approximate the product in (3.9) as

$$F_{\lambda}(\nu) = e^{-4\lambda\nu^2}; \quad \lambda = \sum_{k=1}^N \tilde{\alpha}_k^2 / 2. \quad (3.10)$$

Notice that λ is just the mean number of environmental spins that are flipped, each time τ flips.

Clearly phase decoherence is important if $\lambda > 1$, in which case $F_{\lambda}(\nu) = \delta_{\nu,0} + \textit{small corrections}$. Then, rather surprisingly, we get a *universal form* (shown in Fig. 6), in the intermediate coupling limit, for $P_{11}(t)$:

$$P_{11}(t) \longrightarrow \frac{1}{2} \left[1 + J_0(4\Delta_o t) \right] \equiv \int \frac{d\varphi}{2\pi} P_{11}^{(0)}(t, \Phi = \varphi) \quad (\textit{intermediate coupling}) \quad (3.11)$$

with a phase integration over the *free* central spin propagator $P_{11}^{(0)}(t, \Phi)$ [cf. eqtn. (A8)]. Thus *random phases* arise because successive flips of $\vec{\tau}$ cause, in general, a different topological phase to be accumulated by the spin environment. In fact, the universal behaviour comes from complete phase phase randomisation^{5,6}, so that all possible phases contribute equally to the answer! The final form shows decaying oscillations, with an envelope $\sim t^{-1/2}$ at long times, which can also be understood by noting that the "zero phase" trajectories contributing to P_{11} constitute a fraction $(2s)!/(2^s s!)^2 \sim s^{-1/2}$ of all possible trajectories, where $s \sim \Delta_o t$.

In the *strong coupling* limit of this model, where the bath spins rotate adiabatically with the the central spin, one has $\alpha_k \rightarrow \pi/2$, so that $F(m) = (-1)^m$ and $P_{11}(t) = \frac{1}{2}[1 + \cos(4\Delta_o t \cos \tilde{\Phi})]$, where $\tilde{\Phi} = \Phi_o + N\pi/2$, i.e., the Haldane/Kramers phase is now $\tilde{\Phi}$, since the N bath spins are forced to rotate with $\vec{\tau}$.

The results for complex α_k are given in Appendix A; the basic ideas behind them (and the techniques for their calculation) are simple elaborations of the above.

B. Average over longitudinal fields: Degeneracy blocking

We now consider the effective Hamiltonian

$$H_{\text{eff}} = 2\Delta_o\tau_x + \tau_z\{\xi_H + \sum_{k=1}^N \omega_k^{\parallel} \hat{\sigma}_k^z\}; \quad (3.12)$$

To solve this we will assume the model discussed previously, in which all $\{\omega_k^{\parallel}\}$ cluster around a single central value ω_o (cf. eqtns (2.24),(2.23), and Fig. 4). Since the bath now just acts as an extra longitudinal field, we are dealing with the trivial case of a biased two-level system, with bias energy $(\xi_H + \epsilon)$, where $\epsilon = \sum_{k=1}^N \omega_k^{\parallel} \sigma_k^z$. The only question is how to average over the internal bias- this depends on whether we deal with a *single* central system, or a statistical ensemble of them (corresponding to either an average over many measurements on a single system, or a single measurement on a large number of *non-interacting* systems- interactions are discussed in section 5.A).

For a single central spin, the dynamics of $\vec{\tau}$ in this model are completely trivial- one has $P_{11}(t) = [1 - (\Delta_o^2/E^2) \sin^2 Et]$, where $E = \xi_H + \epsilon$, i.e., resonant tunneling of an isolated spin in a longitudinal bias field (compare (A4)).

For an *ensemble* of central spins, we must average over the whole bias range. In what follows let us assume for definiteness a spin bath at some equilibrium temperature $T = 1/\beta$; then the ensemble average is just a *weighted average over bias*:

$$\int d\epsilon W(\epsilon) \frac{e^{-\beta\epsilon}}{Z(\beta)} \quad (3.13)$$

where $Z(\beta)$ is the appropriate partition function.

$$P_{11}(t) = \int d\epsilon W(\epsilon) \frac{e^{-\beta\epsilon}}{Z(\beta)} \left[1 - \frac{2\Delta_o^2}{(\epsilon + \xi_H)^2 + 4\Delta_o^2} \left(1 - \cos(2t\sqrt{(\epsilon + \xi_H)^2 + 4\Delta_o^2}) \right) \right] \quad (3.14)$$

The physical interpretation is obvious⁵; only a very small fraction $A(\xi_H) \sim \Delta_o/E_o$ of central spins in the ensemble in the "resonance window", i.e., having total bias $|(\xi_H + \epsilon)| \leq \Delta_o$, can make transitions- this selects states with internal bias around $\epsilon \sim -\xi_H$. All other states lack the near-degeneracy between initial and final energies required for resonant tunneling- they are "degeneracy blocked"^{5,9}. The resulting correlation function is then

$$P_{11}(t) = 1 - 2A(-\xi_H) \sum_{k=0}^{\infty} J_{2k+1}(4\Delta_o t). \quad (3.15)$$

where $A(\xi) = \Delta_o W(\xi)$ (except in the unphysical case where the polarisation group linewidths $\tilde{\Gamma}_M < \Delta_o$. For the usual case where all polarisation groups overlap, and $W(\epsilon)$ has the Gaussian form (2.23), one has $A(\xi)/(2\pi)^{1/2} = (\Delta_o/E_o) \exp(-2\xi^2/E_o^2)$. It is not surprising to find that the spectral absorption function $\chi''(\omega) = \text{Im} \int dt P_{11}(t)$, corresponding to (3.15), has the "BCS" form

$$\chi''(\omega) = A(-\xi_H) \frac{8\Delta_o}{\omega \sqrt{\omega^2 - 16\Delta_o^2}} \eta(\omega - 4\Delta_o), \quad (3.16)$$

Finally, let us note that one may imagine a case where one has an ensemble of systems in which, although the bath state is not fixed, the polarisation group is known to be equal to M . In this case we must replace (3.13) by

$$\int d\epsilon G_M(\epsilon) \frac{e^{-\beta\epsilon}}{Z_M(\beta)} \quad (3.17)$$

in (3.14) for $P_{11}(t)$, where $Z_M(\beta)$ is the partition function for the M -th polarisation group. If we then recalculate $\chi''(\omega)$ in the same way we find almost zero absorption unless $|M\omega_o + \xi_H| < \text{Max}(\Delta_o, \tilde{\Gamma}_M)$, where $\tilde{\Gamma}_M$ is again the linewidth of the M -th polarisation group (cf. (2.22)).

C. Average over transverse fields: Orthogonality blocking

Until now we have ignored the "transverse field" part $\sum_{k=1}^N \omega_k^\perp \vec{m}_k \cdot \hat{\vec{\sigma}}_k$ of the diagonal term in the effective Hamiltonian (2.16). To study this let us consider again an effective Hamiltonian which has no non-diagonal terms apart from the "bare" tunneling, but having all diagonal terms:

$$H_{\text{eff}} = 2\Delta_o \tau_x + \hat{\tau}_z \omega_o^\parallel \sum_{k=1}^N \vec{l}_k \cdot \hat{\vec{\sigma}}_k + \sum_{k=1}^N \omega_k^\perp \vec{m}_k \cdot \hat{\vec{\sigma}}_k, \quad (3.18)$$

We will assume $\omega_o^\parallel \gg \omega_o^\perp$, ie., that the transverse "orthogonality blocking" part of the diagonal interaction is much smaller than the longitudinal part. To make things as simple as possible we drop all degeneracy blocking effects, ie., we assume all ω_k^\parallel are equal (ie., $\mu = 0$). It then follows that the spin bath spectrum is split by ω_o^\parallel into $2N$ "polarization groups" of degenerate lines, with $C_N^{(N+M)/2}$ degenerate states in polarisation group M (cf. eqtn. (2.21)).

At first glance it seems that the $\{\vec{\sigma}_k\}$ in (3.18) simply act on the central spin $\vec{\tau}$ as an external field. However this is *wrong*; it ignores their role as dynamic quantum variables. The dynamics come because the $\{\vec{\sigma}_k\}$ can *precess* in the fields $\{\vec{\gamma}_k\}$ acting on them, and these change each time $\vec{\tau}$ makes a transition (cf. eqtn. (2.19)). Quantum mechanically, the precession caused by ω_k^\perp is equivalent to saying that some bath spins are *flipped* when the central spin $\vec{\tau}$ flips (in general a different number of them during each transition of $\vec{\tau}$). To see this formally, recall that ω_k^\perp exists when the initial and final fields $\vec{\gamma}_k^{(1)}$ and $\vec{\gamma}_k^{(2)}$ acting on $\vec{\sigma}_k$ are not exactly equal and opposite (cf. eqtn (2.19)). Defining the small angle β_k by $\cos 2\beta_k = -\vec{\gamma}_k^{(1)} \cdot \vec{\gamma}_k^{(2)} / |\vec{\gamma}_k^{(1)}| |\vec{\gamma}_k^{(2)}|$ (recall Fig. 3), we see that the initial and final states of $\vec{\sigma}_k$ are related by

$$|\vec{\sigma}_k^f\rangle = \hat{U}_k |\vec{\sigma}_k^{in}\rangle = e^{-i\beta_k \hat{\sigma}_k^x} |\vec{\sigma}_k^{in}\rangle. \quad (3.19)$$

Suppose now the initial spin bath state belongs to polarisation group M . If, when $\vec{\tau}$ flips, bath spins also flip so that $M \rightarrow -M$, then since $E_\uparrow(M) = E_\downarrow(-M)$, *resonance* is still preserved, a transition is possible- indeed $\vec{\tau}$ cannot flip at all *unless* there is a change in polarisation state of magnitude $2M$. For this change in polarisation of $2M$, *at least* M spins must flip; moreover, for resonant transitions to continue (incoherently), the bath polarisation state must change by $\pm 2M$ *each time* $\vec{\tau}$ flips.

Let us therefore define $P_M(t)$ as the correlation function $P_{11}(t)$ restricted to systems for which the bath polarisation is M . For a thermal ensemble,

$$P_{11}(t; T) = \sum_{M=-N}^N w(T, M) P_M(t), \quad (3.20)$$

with a weighting $w(T, M) = Z^{-1} C_N^{(N+M)/2} e^{-M\omega_o^\parallel/k_B T}$, where Z is the partition function.

In Appendix A.2 we calculate $P_M(t)$ (see Eq. (A27)) as a *weighted average over an orthogonality variable* x :

$$P_M(t) = \int_0^\infty dx x e^{-x^2} \left(1 + \cos[4\Delta_\Phi J_M(2x\sqrt{\kappa})t] \right) \quad (3.21)$$

$$= 2 \int_0^\infty dx x e^{-x^2} P_{11}^{(0)}(t, \Delta_M(x)), \quad (3.22)$$

where $P_{11}^{(0)}(t, \Delta_M)$ is just the usual *free* 2-level correlator (Eq.(A1)), but now with an an x -dependent tunneling amplitude $\Delta_M(x) = 2\Delta_\Phi J_M(2x\sqrt{\kappa})$; and κ is the "orthogonality exponent", defined by

$$e^{-\kappa} = \prod_{k=1}^N \cos \beta_k \sim e^{-(1/2) \sum_k \beta_k^2}, \quad (3.23)$$

The orthogonality blocking term β_k is analogous to the topological decoherence term α_k . It is important to understand why we must introduce the average over x . Mathematically, it comes from the restriction to a single polarisation group (see Appendix A.2). Physically, it corresponds to a phase average just like that in (3.8) (compare the Bessel functions), but now the phase is that accumulated *between* transitions of the central spin (rather than *during* these transitions, as in topological decoherence). This phase accumulates if $\omega_k^\perp \neq 0$, because then the field $\vec{\gamma}_k$ on the k -th

bath spin does not exactly reverse when the central spin flips, and so this spin must start precessing in the new field. It is random simply because the waiting time between flips is a random variable, in the path integral.

We shall not give full details for the dynamics of this limiting case (for which see ref⁸), but just enough to understand the physics. First, note that the terms $P_M(t)$ are easily verified to be incoherent, and so $P_{11}(t) \sim f P_{M=0}(t) + \text{incoherent}$, where $f = \sqrt{2/\pi N}$. Even the small fraction f of systems in an ensemble having $M = 0$ will only have coherent dynamics if $\kappa \ll 1$. The easiest way to see this is to again calculate the spectral absorption function from (3.21), to get:

$$\chi''_{M=0}(\omega) = \frac{\pi f}{2\Delta_o \kappa^{1/2}} \sum_j \frac{x_j e^{-x_j^2}}{|J_1(2\kappa^{1/2} x_j)|} \Big|_{J_0(2\kappa^{1/2} x_j) = \pm(\omega/2\Delta_o)} \quad (3.24)$$

which leads, as κ increases, to an ever-increasing number of square-root singularities in $\chi''_{M=0}(\omega)$. For $\kappa < O(1)$ only a single root $x_1 \sim [(1 - \omega/2\Delta_o)/\kappa]^{1/2}$ enters, and $\chi''_{M=0}(\omega) \sim (\pi f/2\Delta_o \kappa) e^{[(1 - \omega/2\Delta_o)/\kappa]}$ for $\omega < 2\Delta_o$, ie., a fairly sharp asymmetric peak at the resonant frequency of the free spin. For larger κ the multiple peaks and tails mix, and $\chi''_{M=0}(\omega)$ shows no obvious peak- moreover, its spectral weight is shifted to ever-lower frequencies:

$$\left. \begin{aligned} P_{M=0}(t) &= 1/2[1 + \cos(4\Delta_{eff}t)] \\ \Delta_{eff} &= 2\Delta_\Phi e^{-\kappa} \end{aligned} \right\} \kappa \ll 1 \quad (3.25)$$

$$\left. \begin{aligned} P_0(t) &= 1 - 4\Delta_{eff}^2 t^2 + O(\Delta_{eff}^4 t^4) \\ \Delta_{eff} &= \Delta_\Phi / (\pi\kappa)^{1/4} \end{aligned} \right\} \kappa \gg 1 \quad (3.26)$$

Notice that this reduction of the transition rate is much slower than the usual polaronic or Anderson/Hopfield orthogonality catastrophe, relevant to oscillator baths, which gives exponential suppression of Δ_{eff} for strong coupling. This is understood as follows. In oscillator bath models, band narrowing comes essentially without any bath transitions (most of the polaron "cloud" is in virtual high-frequency modes) - it is adiabatic. Here, however, roughly κ spins flip each time \vec{S} flips (the probability of r flips is $\kappa^r e^{-\kappa}/r!$, which peaks at $r \sim \kappa$), even though we only consider $P_{M=0}(t)$, i.e., even though $\Delta M = 0$ (just as many bath spins flip one way as the other).

A further examination of the correlation function shows that the structure of $P_{M=0}(t)$ is exceedingly bizarre- it was described in detail in ref.^{7,8}. In section 4.A and Fig. 8 we will return to the physics of orthogonality blocking, but including other mechanisms as well (see also Fig. 7 below).

D. Averaging over spin bath fluctuations

The previous 3 averages assume no intrinsic spin bath dynamics- the bath acquired its dynamics from the central spin. Consider now a Hamiltonian

$$H_{\text{eff}} = \Delta\tau_x + \xi\tau_z + \tau_z \sum_{k=1}^N \omega_k^\parallel \hat{\sigma}_k^z + \sum_{k=1}^N \sum_{k'=1}^N V_{kk'}^{\alpha\beta} \hat{\sigma}_k^\alpha \hat{\sigma}_{k'}^\beta ; \quad (3.27)$$

in which we assume $|V_{kk'}| \ll \omega_k^\parallel$, but arbitrary $V_{kk'}/\Delta$. The addition of $V_{kk'}$, to what would have been a simple degeneracy blocking Hamiltonian, gives the spin bath its dynamics, and causes 2 changes (as noted previously in our introductory presentation of the central spin model). First, a polarisation group M acquires an "intrinsic linewidth" $\Gamma_o \sim V_o N^{1/2}$, where V_o is a typical value of $|V_{kk'}|$ for the N bath spins (of course normally $\Gamma_o \ll \tilde{\Gamma}_M$, unless the $\{\omega_k^\parallel\}$ happen to be extremely tightly bunched together). Second, the transverse part of $V_{kk'}^{\alpha\beta}$ causes pairwise flipping amongst bath spins (eg., transitions $|\uparrow_k \downarrow_{k'}\rangle \rightarrow |\downarrow_k \uparrow_{k'}\rangle$), at a rate $\sim NT_2^{-1}$, where $T_2^{-1} \sim V_o$. This "spin diffusion" in the bath causes the internal bias ϵ to fluctuate in time, inside the energy range of the polarisation group M , with a random walk correlation $\langle [\epsilon(t) - \epsilon(t')]^2 \rangle = \Lambda^3 |t - t'|$, where $\Lambda^3 = \tilde{\Gamma}^2 T_2^{-1}$, for timescales $\Lambda |t - t'| \ll 1$.

It thus follows that for a given *single* central spin, with its surrounding spin bath in polarisation group M , the problem reduces to calculating the dynamics of a 2-level system in a longitudinal bias field ($\xi + \epsilon(t)$), where ξ is the applied bias, and the internal field is $\epsilon(t) = M\omega_o + \delta\epsilon(t)$. The correlation properties of $\delta\epsilon(t)$ are those just described- our task is simply to functionally average over these fluctuations in the calculation of $P_{11}(t)$. In doing this we will make the physically sensible assumption of "fast diffusion" of $\delta\epsilon(t)$, such that the time Δt it takes for the bias to diffuse across the "resonance window", of energy width Δ , satisfies $\Delta t \ll 1/\Delta$. Then the system has no

time to tunnel coherently, but can only make an incoherent "Landau-Zener" transition. Since the bias changes by $\delta\epsilon \sim \delta\omega_o(N/(T_2\Delta))^{1/2}$ in a time $1/\Delta$, this formally requires that

$$\Delta^3 \ll \Lambda^3 \equiv \tilde{\Gamma}^2 T_2^{-1} \quad (\text{fast diffusion}). \quad (3.28)$$

This problem is solved in Appendix A, by performing a *weighted average over dynamic bias fluctuations*, with the restriction that these only occur inside polarisation group M ; the relevant average is

$$\int \mathcal{D}\epsilon(t) e^{-\frac{1}{2} \int dt_1 \int dt_2 K(t_1-t_2)\epsilon(t_1)\epsilon(t_2)} ; \quad (3.29)$$

where $2K^{-1}(t_1-t_2) = \Lambda^3(|t_1| + |t_2| - |t_1-t_2|)$ is the correlator of the dynamic spin bath fluctuations (see Appendix A). One finds that $P_{11}(t)$ decays as a simple exponential $P_{11}(t) = e^{-t/\tau_M(\xi)}$, where

$$\tau_M^{-1} = 2\pi^{1/2} \frac{\Delta^2}{\tilde{\Gamma}} e^{-(\xi+M\omega_o)^2/\tilde{\Gamma}^2} \quad (3.30)$$

This result is easily understood- the bias fluctuations can cause the system to pass briefly through resonance (allowing a transition of the central spin), but only if the net static bias $\xi + M\omega_o$ is not greater than the range $\tilde{\Gamma}$ of the fluctuations. By comparing with the case of pure degeneracy blocking we see that the important role of the bath dynamics is (i) to *unblock* the central spin dynamics, by helping it to find resonance, now over an energy window of width $\tilde{\Gamma}$ (instead of Δ_o) around zero bias (recall Fig. 4), and (ii) to change the central spin dynamics from coherent to incoherent tunneling.

Note that in a model like (3.27) we have eliminated bath fluctuations between different polarisation groups. The basic assumption is that any " T_1 processes" in the intrinsic bath dynamics, which could change M in the absence of the central spin, are very slow (At low T , T_1 for nuclear or paramagnetic spins does become extremely long). However this is not always realistic- we return to this point in section 5.A. If T_1 is short, one must make a dynamical average over 2 kinds of fluctuation, usually with quite different time correlation, viz., the intra-polarisation group fluctuations, described by (3.29) and with correlation time NT_2^{-1} , and the inter-polarisation group fluctuations, occurring on a timescale T_1 (cf. ^{69,70}).

E. Averaging over the Spin Bath: General Results

We now turn to the problem of averaging over the spin bath for the general form of the Central Spin Hamiltonian given in eqtn. (2.16). This can be given in the form of a marvellously simple prescription- one simply applies the 4 averages we have just seen, to the problem of a simple biased 2-level system! We begin by giving the explicit prescription (whose proof is given in Appendix B), and make a few comments on it.

The prescription begins with the following 4 averages (all of which we have seen in the preceding 4 sub-sections):

$$(a) \text{ A "topological phase average" } \quad \sum_{\nu=-\infty}^{\infty} F_{\lambda'}(\nu) \int \frac{d\varphi}{2\pi} e^{i2\nu(\Phi-\varphi)} ; \quad (3.31)$$

$$(b) \text{ An "orthogonality average" } \quad 2 \int_0^{\infty} dx x e^{-x^2} ; \quad (3.32)$$

$$(c) \text{ A "bias average" } \quad \int d\epsilon G_M(\epsilon) \frac{e^{-\beta\epsilon}}{Z_M(\beta)} \quad \text{OR} \quad \int d\epsilon W(\epsilon) \frac{e^{-\beta\epsilon}}{Z(\beta)} \sum_M ; \quad (3.33)$$

$$(d) \text{ A "bath fluctuation average" } \quad \int \mathcal{D}\epsilon(t) e^{-\frac{1}{2} \int dt_1 \int dt_2 K(t_1-t_2)\epsilon(t_1)\epsilon(t_2)} ; \quad (3.34)$$

As before, we assume a thermal distribution over spin bath biases, with a corresponding partition function and $Z(\beta)$. All averages are normalized to unity. The weighting function $F_{\lambda'}(\nu) = e^{-4\lambda'\nu^2}$ in (3.31) is a generalisation of that in (3.10), to allow for arbitrary directions of the unit vector \hat{n}_k ; we now define

$$\lambda = \frac{1}{2} \sum_k |\alpha_k|^2 (1 - (n_k^z)^2), \quad \lambda' = \frac{1}{2} \sum_k \alpha_k^2 (n_k^z)^2, \quad (3.35)$$

Now, suppose we want to calculate $P_{11}(t)$. The prescription is fairly obvious in the light of the results given above for the 4 limiting cases. One follows the following steps:

(i) Begin with the quantity

$$P_{11}^{(0)}(t; \Delta_M(\varphi, x); \epsilon) = 1 - \frac{\Delta_M^2(\varphi, x)}{E_M^2(\varphi, x)} \sin^2(E_M(\varphi, x)t), \quad (3.36)$$

which is just the *free* central spin correlator (cf. (A4)) having tunneling matrix element $\Delta_M(\varphi, x)$, and in an "internal field" bias ϵ . The energy splitting E_M is given by $E_M^2(\varphi, x) = \Delta_M^2(\varphi, x) + \epsilon^2$, and the matrix element Δ_M is

$$\Delta_M(\varphi, x) = 2\tilde{\Delta}_o |\cos(\varphi) J_M(2x\sqrt{\gamma})|, \quad (3.37)$$

$$\gamma = \begin{cases} \lambda & \text{if } \lambda \gg \kappa \text{ (topological decoherence regime)} \\ \kappa & \text{if } \kappa \gg \lambda \text{ (orthogonality blocking regime)} \end{cases}. \quad (3.38)$$

We defined κ previously (eqtn. (3.23)). We will not give results for the case $\kappa \sim \lambda$; they are extremely complex, do not appear to add new physics, and seem unlikely to be realised in practice.

(ii) Now carry out the averages over topological phase [Eq. (3.31)] and orthogonality [Eq. (3.32)], to give an expression $P_M(t, \epsilon)$ describing the central spin dynamics in a bias ϵ , coming from a bath in polarisation state M :

$$P_M(t; \epsilon) = 2 \int_0^\infty dx x e^{-x^2} \sum_{\nu=-\infty}^\infty F_{\lambda'}(\nu) \int \frac{d\varphi}{2\pi} e^{i2\nu(\Phi-\varphi)} \left[1 - \frac{\Delta_M^2(\varphi, x)}{E_M^2(\varphi, x)} \sin^2(E_M(\varphi, x)t) \right], \quad (3.39)$$

where the weighting function is $F_{\lambda'}(\nu) = e^{-4\lambda'\nu^2}$ over winding number ν (recall eqtn. (3.10));

(iii) Then, carry out the bias average [Eq. (3.33)]. We will assume in the following for definiteness an ensemble average over all polarisation groups, thereby ensuring a summation over M , to give

$$P_{11}(t; T) = 1 - \int d\epsilon W(\epsilon) \frac{e^{-\beta\epsilon}}{Z(\beta)} \sum_{M=-N}^N (1 - P_M(t, \epsilon - M\omega_o)); \quad (3.40)$$

This result summarizes the central spin dynamics in the case where the spin bath has no dynamics of its own, and only acquires dynamics through its interaction with the central system. In some cases there will be no intrinsic bath dynamics, and this will be the final answer. If we wish to apply the theory to a single central system, or for some reason we can fix the polarisation group to be a definite value M , then we drop the summation over M in (3.40), and replace $W(\epsilon)$ by $G_M(\epsilon)$.

(iv) When the interaction term $V_{kk'}$ plays a role, we apply the 4th average (3.34) to (3.40), as described in Appendix A (cf. also the discussion in ref.⁹). This gives the completely incoherent form

$$P_{11}(t) = \sum_M w(T, M) \int x dx e^{-x^2} \sum_{\nu=-\infty}^\infty \int \frac{\varphi}{2\pi} F_{\lambda'}(\nu) e^{i2\nu(\Phi-\varphi)} [1 + e^{-t/\tau_M(x, \varphi)}], \quad (3.41)$$

where the relaxation rate $\tau_M^{-1}(x, \varphi)$ is given by

$$\tau_M^{-1}(x, \varphi) = 2\Delta_M^2(x, \varphi) \int d\epsilon G_\mu(\epsilon) \int_0^\infty ds e^{i\epsilon s} e^{-\Lambda^3 s^3/6} = 2\Delta_M^2(x, \varphi) \int_0^\infty ds e^{-(\mu\omega_o)^2 s^2/4} e^{-\Lambda^3 s^3/6}; \quad (3.42)$$

with $\Delta_M(x, \varphi)$ given by (3.37), and where $G_\mu(\epsilon)$ is a Gaussian of width $\tilde{\Gamma} = \mu\omega_o$. Since $\tilde{\Gamma} \gg T_2^{-1}$ we have also $\tilde{\Gamma} \gg \Lambda$, and so we get

$$\tau_M^{-1}(x, \varphi) = \frac{2\Delta_M^2(x, \varphi)}{\pi^{1/2}\tilde{\Gamma}}, \quad (3.43)$$

This result is the most general one for the dynamics of the central spin, if all 4 bath averages are included- it is generally valid, with only the single restriction that the diffusion of the fluctuating bath bias in energy space be *fast* (cf. eqtn. (3.28). In the absence of such fluctuations we go back to (3.40).

In essentially all physically realistic cases the different polarisation groups strongly overlap. It is then simpler⁹ to transform the sum over M in (3.40) or (3.43) into an integral over energy bias ξ , using the change of variables $\sum_M \rightarrow \int d\xi/2\omega_o$, and then integrate over ξ . One way to do this (using steepest descents) was detailed in ref.⁹ (compare eqtns (4.41)-(4.47) in that paper). For exact answers one can use the identity

$$\int_0^\infty x dx e^{-x^2} J_M^2(2x\sqrt{\gamma}) \cos^2 \phi = I_M(2\gamma) e^{-2\gamma} \cos^2 \phi \quad (3.44)$$

to evaluate either (3.40) or (3.41).

In the next section we will evaluate $P_{11}(t)$ and its Fourier transform for a number of different parameter regimes. But even before doing the integrals, the qualitative behaviour is obvious. Relaxation is only occurring for central spins which happen to be within a bias ξ_o of exact resonance. The width ξ_o of this "resonance window" is coming from the energy which the bath spins can provide to the central spin, by flipping up to $\sim \gamma$ bath spins; hence $\xi_o \sim \gamma\omega_o$ (formally this is obvious from the properties of the Bessel functions in (3.37) and (3.44), which fall off very fast once $M > \gamma$). We show graphically the relaxation of different groups in Fig. 7(a); again one sees how only groups with $M \leq \gamma$ relax quickly. The T_2 bath fluctuations help this process by bringing the a central spin in polarisation group M to its resonance window (of width Δ_M). Only transitions of systems having $M = 0$ can show (partial) coherence; all transitions with $M \neq 0$ are essentially *incoherent*. Note that the resonance window will *not* be visible in a resonant absorption experiment (Fig. 7(b)); higher M groups contribute only a very low frequency contribution to this. This nicely demonstrates that one is very far from any linear-response regime in the present system (so that, e.g., the fluctuation-dissipation theorem is somewhat irrelevant here).

Without the bath, transitions of the central spin would be coherent, but over the far smaller resonance window of width $\sim \Delta_o$. If we only had T_2 bath fluctuations, but $\gamma \ll 1$ (ie., no bath spins flipped during the transitions of the central spin), then we would again get incoherent relaxation, but this time with $\xi_o \sim \tilde{\Gamma}_{M=0}$ (the width of the $M = 0$ polarisation group). One can also imagine a situation in which T_1 is very short, so that all polarisation groups are involved in the relaxation, and the resonance window is just the distribution $W(\xi)$, with $\xi_o = E_o = N^{1/2}\omega_o$.

These results thus tell us that in the presence of a spin bath, any ensemble of central spins, initially spread over a range of biases, will start relaxing by digging a "hole" of width ξ_o around zero bias^{9,35}. This hole reflects the *intrinsic* central spin dynamics (ie., it is not being produced by interaction with some external resonant signal- it should not be confused in any way with the "spectral hole-burning" done by experimenters working on glasses or in optics, using an external source). As discussed in a number of papers^{9,35}, evaluation of (3.41), using either steepest descents or other means, shows that the system under most conditions relaxes incoherently with a relaxation rate (after summing over all polarisation groups, and doing the orthogonality and phase integrals) given approximately as a function of bias ξ by

$$\tau^{-1}(\xi) = \tau_o^{-1} e^{-|\xi|/\xi_o} \equiv \frac{2\Delta^2}{\pi^{1/2}\tilde{\Gamma}} e^{-|\xi|/\xi_o} \quad (3.45)$$

All of this is in complete contrast to how inelastic tunneling works in the presence of an oscillator bath¹⁰; there the relaxation rate typically *increases* as one moves away from resonance, usually as a power in bias ($\tau^{-1}(\xi) \sim \xi$ for diagonal coupling to phonons, $\sim \xi^3$ for non-diagonal coupling to phonons, and $\sim \xi^{2\alpha-1}$ for diagonal coupling to Ohmic baths like electrons via a dimensionless coupling α). Thus one does not expect hole-digging for oscillator bath-mediated quantum relaxation, except over a very narrow region of width $\sim \Delta_o$.

Finally, we note that one may also give a formal prescription for the case where some central spin couples simultaneously to an oscillator bath *and* a spin bath. We do not give the details here- they are discussed fairly exhaustively (along with the results for the central spin dynamics) in ref.⁹ (see also end of section 4).

IV. DYNAMICS OF THE CENTRAL SPIN

Given the large number of parameters entering into the 4 averages just described, we see little point in an exhaustive description of $P_{11}(t)$ over the whole parameter domain (for more extensive results see refs.^{7,9}). Instead we concentrate on 3 points. First, we show how in the strong coupling regime, coherence is destroyed, leaving incoherent quantum

relaxation; this regime applies to almost all mesoscopic or nanoscopic magnetic systems, because of their coupling to nuclear spins and to paramagnetic impurities. Second, we discuss the physics of the weak coupling regime (applicable to, eg., SQUIDS), and how in one limit of this regime one may formally map the spin bath to an oscillator bath. Finally, and very briefly, we comment on the results obtained when one couples simultaneously to a spin bath and an oscillator bath.

A. Strong coupling regime

As already explained, the strong-coupling regime is defined by the condition ω_k^\parallel and/or $\omega_k^\perp \geq \Delta_o$. This condition applies to virtually all situations in which the couplings are hyperfine ones to nuclear spins, or exchange couplings to paramagnetic spins; and also when one has dipolar couplings to paramagnetic impurities or defects.

Almost all interesting physical examples in this regime fall either into the category of “strong orthogonality blocking” (when $\kappa \gg \lambda'$) or strong “phase decoherence” (when $\lambda \gg \kappa$). In both cases the central system makes transitions accompanied by flips in the bath spins- so that even if the isolated central system is not in resonance, it can “find resonance” by using the flipped bath spins to make up the energy difference. If the couplings are such that roughly κ bath spins flip, the range of energy bias over which transitions can occur is extended to roughly $2\kappa\omega_o$. The central system is helped in this task by the fluctuations in bath bias caused by the interspin interactions $V_{kk'}$.

In what follows we concentrate on the physics of *decoherence* in this regime, with an eye to the physics of “qubits” and of “macroscopic quantum coherence”. We also look at the form of the relaxation. We begin by explaining the results without the bath fluctuations, and then show what happens on adding these.

(i) Results without bath fluctuations: In this case we must evaluate (3.40) and (3.39), suppressing either the orthogonality average or the topological average. In what follows we look at each case in turn, focussing particularly on the $M = 0$ polarisation group contribution.

(a) Orthogonality Blocked regime ($\kappa \gg \lambda$). In this regime only the orthogonality average $2 \int dx dx e^{-x^2}$, and the average over bias ϵ , are relevant- the phase average is approximated by a delta-function. The presence of the x -dependent transition matrix element $\Delta_M(x) = 2\Delta_o J_M(2x\sqrt{\kappa})$ means that polarisation groups with $M \sim \kappa$ play a dominant role. Suppose however that we are interested in any coherent dynamics of the central spin- what will be found? It is obvious that transitions with finite M will be essentially incoherent, so we concentrate on central spins for which $M = 0$. Thus we simply integrate $P_M(t, \epsilon)$ over ϵ , in the weighted bias average, to get

$$P_{11}^{M=0}(t) = 1 - 4A \int dx x e^{-x^2} |J_0(2x\sqrt{\kappa})| \sum_{k=0}^{\infty} J_{2k+1}[4\Delta_o |J_0(2x\sqrt{\kappa})| t] \quad (4.1)$$

$$= 1 - 2 \int dx x e^{-x^2} 2A(x) \sum_{k=0}^{\infty} J_{2k+1}[2\Delta_0(x)t], \quad (4.2)$$

where the x -dependent spectral weight is $A(x) = A|J_0(2x\sqrt{\kappa})|$. Notice we have just done an “orthogonality average” over a “biased averaged” expression for the free system with x -dependent tunneling frequency $\Delta_0(x)$. A Fourier transform to frequency space (which is essentially a picture of the relaxation rate, as a function of *energy bias* ξ for this system) gives the absorption spectrum

$$\chi''_{M=0}(\omega) = \frac{1}{\omega} \int dx x e^{-x^2} 4A(x) \frac{|\Delta_0(x)|}{[\omega^2 - 4\Delta_0^2(x)]^{1/2}} \eta(\omega - 2|\Delta_0(x)|), \quad (4.3)$$

Fig. 8 shows some representative plots for this “coherent” part of $\chi''(\omega)$; it is in fact *almost completely incoherent*, with total spectral weight

$$\begin{aligned} \int_{-\infty}^{\infty} (d\omega/2\pi) \chi''(\omega) &= 2A \int dx x e^{-x^2} |J_0(2\sqrt{\kappa}x)| \\ &= \frac{2\Gamma(3/4)}{\pi^{3/2}} \frac{A}{\kappa^{-1/4}}; \end{aligned} \quad (4.4)$$

a result which is very accurate even for $\kappa \sim 0.02$. Note that the shape of $\chi''(\omega)$ will change once we include all other (incoherently relaxing) polarization sectors $M \neq 0$, and its total weight increases - in fact the total weight is $\sim A\kappa^{1/4}$ for large κ , since $\sim \kappa^{1/2}$ different polarization sectors contribute. The absorption in $\chi''(\omega)$ from these higher

M groups will be concentrated at frequencies $\ll \Delta_o$ (compare also Fig 7(b)). Note however that relaxation itself (not described by the linear response function $\chi''(\omega)$) will be spread incoherently over a frequency range $\xi_o \sim 2\kappa\omega_o$, ie., the "hole-digging" in the relaxation occurs over a window of width $\xi_o \sim 2\kappa\omega_o$.

(b) *Phase decoherence regime* ($\lambda \gg \kappa$). Let us now suppose the transverse field terms $\{\omega_k^\perp\}$ are negligible compared to the $\{\tilde{\alpha}_k\}$. We then deal with an effective Hamiltonian

$$H_{\text{eff}} = 2\Delta_o \left\{ \hat{\tau}_- \cos [\Phi - i \sum_{k=1}^N \alpha_k \vec{n}_k \cdot \hat{\sigma}_k] + H.c. \right\} + \hat{\tau}_z \sum_{k=1}^N \omega_k^\parallel \hat{\sigma}_k^z. \quad (4.5)$$

Since $\omega_k^\parallel \gg \Delta_o$ by assumption, energy conservation requires that environmental spins flip with the central spin, just as in our discussion of pure orthogonality blocking. Thus in this case *we must also keep the orthogonality average*, to enforce this constraint, ie., we must perform the full average embodied in eqtns. (3.39),(3.40). The full answer, including both the real and imaginary parts of α_k , is rather complicated, and is presented in Appendix B. Here we will consider the more transparent answer one gets when α_k is purely imaginary and adds to directly as a random variable to the central spin phase.

Let us again start with only the $M = 0$ contribution to $P_{11}(t)$. Then we have

$$P_{11}^{M=0}(t) = \int d\epsilon W(\epsilon) \frac{e^{-\beta\epsilon}}{Z(\beta)} P_0(t, \epsilon); \quad (4.6)$$

with $P_0(t, \epsilon)$ given by (3.40) with $M = 0$. We may now carry out the integration in (4.6), assuming that $W(\epsilon)$ is given by the usual Gaussian form (2.23), to get

$$P_{11}^{M=0}(t) = 1 - 2 \int_0^\infty dx x e^{-x^2} \sum_{\nu=-\infty}^\infty F_{\lambda'}(\nu) \int \frac{d\varphi}{2\pi} e^{i2\nu(\Phi-\varphi)} 2A(\varphi, x) \sum_{k=0}^\infty J_{2k+1}[2\Delta_0(\varphi, x)t]; \quad (4.7)$$

with $A(\varphi, x) = A \cos \varphi J_0(2x\sqrt{\lambda})$. The corresponding absorption $\chi''(\omega)$ is

$$\chi''_{M=0}(\omega) = \frac{2}{\omega} \int dx x e^{-x^2} \sum_{\nu=-\infty}^\infty F_{\lambda'}(\nu) \int \frac{d\varphi}{2\pi} e^{i2\nu(\Phi-\varphi)} \frac{A(\varphi, x)\Delta_0(\varphi, x)}{[\omega^2 - 4\Delta_0^2(\varphi, x)]^{1/2}}. \quad (4.8)$$

It is possible to write analytic expressions starting from (4.8), but in this somewhat pedagogical presentation we simply discuss the case when $\mu = 0$, i.e., zero degeneracy blocking, when $\omega_k = \omega_o$ for all nuclei. The integration over bias is then absent (since $W(\epsilon)$ is now just a set of δ -function peaks, ie., $W(\epsilon) \rightarrow \sum_{M=-N}^N C_N^{(N+M)/2} \delta(\epsilon - M\omega_o)$), and we get

$$P_{11}(t) = \sum_M w(T, M) P_M(t); \quad w(T, M) = C_N^{(N+M)/2} e^{-M\omega_o/T} / Z(\beta), \quad (4.9)$$

where $P_M(t)$ now describes the dynamics in zero bias; it is given by exactly the same weighted average over phase as in (3.8):

$$P_M(t) = \int dx x e^{-x^2} \sum_{m=-\infty}^\infty F_{\lambda'}(m) \int \frac{d\varphi}{2\pi} e^{i2m(\Phi-\varphi)} \left\{ 1 + \cos[4\Delta_o t J_M(2x\sqrt{\lambda}) \cos \varphi] \right\} \quad (4.10)$$

$$= \int dx x e^{-x^2} \left\{ 1 + \sum_{m=-\infty}^\infty (-1)^m F_{\lambda'}(m) e^{i2m\Phi} J_{2m}[4\Delta_o t J_M(2x\sqrt{\lambda})] \right\}, \quad (4.11)$$

This can be interpreted *either* as an orthogonality-blocked expression, with frequency scale $\Delta_M(\varphi, x) = 2\Delta_o \cos(\varphi) J_M(2x\sqrt{\lambda})$ which is then *averaged over* φ , to give phase randomisation; *or* as an integration $\int dx$ over an *already topologically decohered* function having frequency scale $\Delta_M(x) = 2\Delta_o J_M(2x\sqrt{\lambda})$. It is intuitively obvious (and easily demonstrated) that only $P_0(t)$ may behave coherently, with a fractional weight $\sim \sqrt{2/\pi N}$ in an ensemble.

There are various interesting cases of (4.11) for $M = 0$. If $\lambda = 0$ (i.e., \vec{n}_k is parallel to \hat{z}), then we go back to pure topological decoherence - the projection operator then commutes with the cosine operator. On the other hand if $\lambda' = 0$, we have pure orthogonality blocking as stated earlier, and in fact when $\lambda' = 0$, the parameter λ plays the

role of κ in (3.21). Notice that whereas the case $\lambda = 0$ can only occur accidentally, $\lambda' = 0$ is quite common - indeed it pertains to the model in Eqs. (2.26).

We really begin to see the analogy between orthogonality blocking and topological decoherence when $\lambda, \lambda' \gg 1$; just as with pure topological decoherence, $F_{\lambda'}(m)$ collapses to a Kronecker delta, and we get the *universal* projected topological decoherence form:

$$P_{11}^{M=0}(t) \longrightarrow \int dx x e^{-x^2} \left[1 + J_0[4\Delta_o t J_0(2x\sqrt{\lambda})] \right] \quad (\mu = 0); \quad (4.12)$$

$$\chi''_{M=0}(\omega) \longrightarrow \sqrt{\frac{2}{\pi N}} \int dx x e^{-x^2} \frac{4}{[16\Delta_o^2 J_0^2(2x\sqrt{\lambda}) - \omega^2]^{1/2}} \eta(4\Delta_o | J_0(2x\sqrt{\lambda}) | -\omega), \quad (4.13)$$

which generalizes the result of (3.11) for pure topological decoherence. Eq.(4.12) should be compared to (3.21).

We show in Fig.9 some results for $\chi''(\omega)$ for selected values of λ . The results are startling; even a very small value of λ significantly washes out pure topological decoherence; but for any large value of λ' , we never get back the pure orthogonality blocking spectrum.

The results in the case where α_k is real, and \hat{n}_k is along the \hat{x} -direction (see Eq. (2.28)) are obtained by simply converting the Bessel functions J_m to Bessel functions of imaginary argument I_m .

Finally, note again that the above discussion of the $M = 0$ polarisation group is irrelevant to the real experimental lineshape- an evaluation of the full expression (3.40), summing over all M , for the $\lambda, \lambda' \gg 1$ regime, simply gives incoherent relaxation^{9,35}, spread over a frequency range $\xi_o \sim \lambda\omega_o$.

(ii) Including Bath Fluctuations: The modification of the above results, occasioned by the intrinsic spin bath fluctuations, was given in detail in Prokof'ev and Stamp⁹. The fluctuations in bias allow the central system to cycle rapidly through the whole range of biases within a given polarisation group (transitions between *different* polarisation groups can occur through T_1 processes- usually much slower). Here we simply recall the main result, which is obtained by summing the relaxation forms from each polarisation group in an ensemble (cf. eqtns. (3.40) and (3.41)), and assuming that the spin bath T_1 is longer than all experimental times scales.

For a single central system, coupled to a spin bath in equilibrium at temperature $kT \gg \omega_o$, one finds that after an initial short-time transient, the relaxation is roughly logarithmic over a very long period; in fact one finds for the strong coupling regime that

$$1 - P(t, \xi_H = 0) \sim \sqrt{\frac{1}{2\pi N}} \frac{\ln(t/\tau_o)}{\ln\left[\frac{1}{e\sqrt{\gamma}} \ln(t/\tau_o)\right]}; \quad (t \ll t_c), \quad (4.14)$$

for times $t \ll t_c$, where $t_c \sim \tau_o(2N/e^2\gamma)^{\sqrt{2N}}$, and $\tau_o = 2\Delta^2/\pi^{1/2}\tilde{\Gamma}$ is the relaxation time of the $M = 0$ polarisation group (compare eqtn. (3.43)); thus t_c is extremely long! For $t \gg t_c$ the system settles down to a rather different behaviour⁹. This logarithmic behaviour can be *roughly* understood⁹ as coming from a distribution of barrier heights, for the different polarisation groups, which are then summed over- as discussed in ref.⁹, section 4.3(b), the final result looks basically the same as that shown in Fig. 7(a). The fastest relaxation comes from the those polarisation groups in the "resonance window" (recall the discussion at the end of section 3).

Two cautionary notes are in order here. First, (4.14) applies to a *single* relaxing system- but in the case of nanomagnetic systems, all experiments until now have been done on large numbers of nanomagnets, coupled together via long-range dipolar forces, which drastically changes the relaxation (see section 5.A below). Second, (4.14) should not be applied uncritically to experiments, even on single quantum systems. This is because in a real experiment there will also be (i) couplings to oscillator baths, and (ii) the relaxation will change once $t \geq T_1$. In superconductors or metals, electronic oscillator baths will often dominate the relaxation¹⁰, even at short times (for their effect on *coherence*, see section 5.C below). Even in insulating systems, one eventually expects the coupling to phonons to take over at long times⁹, since this causes exponential decay- even if very slow, this will eventually become faster than the spin bath-mediated logarithmic decay in (4.14).

B. The weak coupling regime; relation to the oscillator bath

A question of considerable theoretical (and practical) interest is the transition to the weak coupling regime, where the perturbation on the central system dynamics by a single bath spin is small (even though the net effect of all bath

spins, measured by parameters like λ or κ , may still be large if N is very large). The weak-coupling regime is thus defined by the condition $\omega_k \ll \Delta_o$, ie., both ω_k^\perp and ω_k^\parallel are $\ll \Delta_o$. Again, a variety of cases is possible depending on how large are ratios like $V_{kk'}/\Delta_o$ and $\omega_k^\perp/\omega_k^\parallel$, or parameters like λ and κ . In the following we will not be exhaustive, but simply consider two theoretically interesting cases, in which $V_{kk'}$ is assumed negligible, and we look at the limiting behaviour arising when either $\omega_k^\perp/\omega_k^\parallel \ll 1$ or $\omega_k^\perp/\omega_k^\parallel \gg 1$. We will also assume $N \gg 1$, otherwise the problem is trivial (the bath has little effect at all).

There are 2 ways to solve for the dynamics in this regime. One is to use the averaging already developed above- this simplifies considerably in the weak- coupling regime. The other is to map the problem onto an oscillator bath one, and then use standard techniques to solve this. We demonstrate the 2 methods by solving one problem with each.

(i) *Longitudinally dominated case* ($\omega_k^\perp/\omega_k^\parallel \ll 1$): We assume the same Hamiltonian as in the discussion of the phase decoherence regime (eqtn. (4.5)), but now we can drop the orthogonality average- the projection to a single polarisation group is not required since $\omega_k^\parallel \ll \Delta_o$. Again, for simplicity we consider the case when α_k is imaginary.

We shall solve this using the techniques previously developed; we let $x = 0$ in (3.37), and hence use a matrix element $\Delta(\varphi) = 2\Delta_o \cos \varphi$ (which is *independent* of M). All polarisation groups overlap, and so we simply average over bias and topological phase:

$$\begin{aligned} P_{11}(t) &= 1 - \int d\epsilon W(\epsilon) \frac{e^{-\beta\epsilon}}{Z(\beta)} \sum_{m=-\infty}^{\infty} F_\lambda(m) \int \frac{d\varphi}{2\pi} e^{i2m(\Phi-\varphi)} \left\{ 1 - \frac{\Delta_0^2(\varphi)}{\epsilon^2 + \Delta_0(\varphi)} \left(1 - \cos \left[2t\sqrt{\epsilon^2 + \Delta_0^2(\varphi)} \right] \right) \right\} \\ &= 1 - \sum_{m=-\infty}^{\infty} F_\lambda(m) \int \frac{d\varphi}{2\pi} e^{i2m(\Phi-\varphi)} 2A(\varphi) \sum_{k=0}^{\infty} J_{2k+1}[2\Delta_0(\varphi)t], \end{aligned} \quad (4.15)$$

with $\Delta_0(\varphi) = 2\Delta_o \cos \varphi$ as before, and $A(\varphi) = A \cos \varphi$. This gives an absorption form

$$\chi''(\omega) = \frac{2A}{\omega} \sum_{m=-\infty}^{\infty} F_\lambda(m) \int \frac{d\varphi}{2\pi} e^{i2m(\Phi-\varphi)} \frac{\cos^2 \varphi}{[(\omega/4\Delta_o)^2 - \cos^2 \varphi]^{1/2}} \eta(\omega/4\Delta_o - |\cos \varphi|), \quad (4.16)$$

which for large λ simplifies to

$$\chi''(\omega) = \frac{2A}{\omega} \int \frac{d\varphi}{2\pi} \frac{\cos^2 \varphi}{[(\omega/4\Delta_o)^2 - \cos^2 \varphi]^{1/2}} \eta(\omega/4\Delta_o - |\cos \varphi|), \quad (4.17)$$

and can be expressed in terms of Elliptic functions.

Notice that since $\omega_k \ll \Delta_o$, the number N of environmental spins must be very large to have a noticeable effect, i.e., for λ to be appreciable. Thus if $\lambda \sim N\alpha_k^2 \sim 1$, since $\alpha_k \sim \omega_k/\Omega_o$, we have $N \sim (\Omega_o/\omega_k)^2 \gg (\Omega_o/\Delta_o)^2$. This not only implies that $\mu = N^{1/2}\delta\omega_k/\omega_o \gg 1$ (ie., very strongly overlapping polarisation groups) but also a Gaussian half-width $N^{1/2}\omega_o \gg \Delta_o$, so that the internal bias $\epsilon \gg \Delta_o$. The reason why the two mechanisms (topological decoherence and degeneracy blocking) are so easily combined is just because this bias is produced by *all* of the environmental spins, whereas only a few of them are actually flipped and their contribution to the bias field is small.

(ii) *Transverse dominated case* ($\omega_k^\perp/\omega_k^\parallel \gg 1$): Consider now the case described by

$$H_{\text{eff}} = \Delta_o \hat{\tau}_x + \sum_{k=1}^N (\omega_k^\perp \hat{\sigma}_k^z + \hat{\tau}_z \omega_k^\parallel \hat{\sigma}_k^x), \quad (4.18)$$

with $\omega_k^\perp/\omega_k^\parallel \ll 1$. One can map this problem to the spin-boson problem, in a way similar to that given in the paper by Caldeira et al.¹⁸. We begin by noting that the time evolution operator for the k -th bath spin, under the influence of a central spin moving along a path $Q_{(n)}(t)$, is just

$$\hat{U}_k(Q_{(n)}, t) = T_\tau \exp \left\{ -i \int_0^t ds [\omega_k^\perp \hat{\sigma}_k^z + Q_{(n)}(s) \omega_k^\parallel \hat{\sigma}_k^x] \right\}, \quad (4.19)$$

Weak coupling means we can expand the time-ordered exponent to second order in ω_k^\parallel ; completing the average in Eq. (3.4), and exponentiating the answer, one derives the influence functional for this problem¹⁸. The "high temperature" result $kT \gg \omega_k^\perp$ is readily found:

$$\mathcal{F}[Q, Q'] = \exp \left\{ - \sum_k \frac{(\omega_k^\parallel)^2}{2} \left| \int_0^t ds e^{2i\omega_k^\perp s} [Q_{(n)}(s) - Q'_{(m)}(s)] \right|^2 \right\}, \quad (4.20)$$

The evaluation of this depends on the distribution of couplings. In the "strong decoherence" case where the bath states are spread over an energy range E_o (defined as usual by $E_o^2 = 2 \sum_k (\omega_k^\parallel)^2$) which is large (ie., $E_o \gg \omega_k^\perp, \Delta_o$), then $\mathcal{F}[Q, Q']$ is simply approximated by its form for a single kink - anti-kink trajectory. With kink at $t = t_1$ and anti-kink at t_2 , one only has a contribution if $\omega_k^\perp (t_2 - t_1) \ll 1$, which gives $\mathcal{F}[Q, Q'] = e^{-\frac{1}{4} E_o^2 (t_2 - t_1)^2}$, ie., a decay on a time scale E_o^{-1} . It then follows that kink/ anti-kink transitions are bound in closed pairs, with phase correlations decaying over a time $\ll \Delta_o^{-1}$, and the leading terms sum to give exponential relaxation, ie., $P_{11}(t) = 1/2(1 - e^{-t/\tau_R})$, with a relaxation rate

$$\tau_R^{-1} = 2\Delta_o \int_0^\infty dt e^{-\frac{1}{4} E_o^2 t^2} \equiv 2 \frac{\sqrt{\pi} \Delta_o^2}{E_o}. \quad (4.21)$$

On the other hand if $E_o \ll \Delta_o$, we will get coherent oscillations of the system over a time scale $\tau_\phi \sim \Delta_o/E_o^2$, ie., over roughly Δ_o^2/E_o^2 oscillation periods. We will use this result below, in discussing the possibility of seeing true mesoscopic quantum coherence effects in SQUIDS and nanomagnets (section 5.C).

It is of course obvious from the original discussion of Feynman and Vernon that in the weak-coupling regime, where an expansion to 2nd order in all bath couplings is sufficient, a mapping to an oscillator bath model must be possible¹³. The method given above is of course not the only one- others are explained in refs.^{11,9,18,16}.

Central Spin coupled to oscillator and spin baths: For reference we also briefly note results for the case where a central spin is coupled simultaneously to a spin bath and an oscillator bath; the Hamiltonian is that in eqn. (2.30), but without the sum over j , (and of course dropping the coupling term $V(\mathbf{r}_i - \mathbf{r}_j)$ between different central spins). Some of the dynamic properties of this model were studied in ref.⁹- a complete study is still lacking. Quite generally one expects that at very short times the dynamics will be controlled by the spin bath, but at longer times incoherent oscillator bath- mediated transitions will take over. However these transitions still contain spin bath effects, via an integration over spin bath bias distribution, to give a result

$$P_{11}(t, \xi) = AZ^{-1}(\beta) \int d\epsilon W(\epsilon - \xi) e^{-\beta(\epsilon - \xi)} \{ f(T, \epsilon) + [1 - f(T, \epsilon)] e^{-t/\tau(\epsilon, T)} \} \quad (4.22)$$

where we assume that the ensemble of central spins is in equilibrium with a bath of oscillators at temperature $T = 1/\beta$, in external bias ξ (for more general cases see ref.⁹). In this case $f(\epsilon) = e^{-\beta\epsilon}/2 \cosh(\beta\epsilon)$, and $\tau(\epsilon; T)$ is the oscillator bath- mediated relaxation time; A is a "renormalisation" constant $\sim O(1)$ coming from the spin bath dynamics. Most features of the results are obvious from (4.22). Thus, the oscillator bath *unblocks* transitions for a central spin way off resonance (ie., having $\xi \gg E_o$); these spins relax much as they would without the spin bath. When $\xi/leq E_o$ there is a wide range of relaxation times, and the physical relaxation depends in a complex way on the oscillator bath spectrum as well as the bias. In any experiment one would see a crossover between purely spin-bath mediated relaxation at short times and this more complex behaviour- this crossover has not yet been studied in any detail.

V. PHYSICAL APPLICATION OF SPIN BATH MODELS

In this section we briefly review some recent work, mainly experimental, in which interactions with a spin bath play a role. We begin with magnetic systems where such interactions are strong, and where clear evidence exists for their influence on tunneling phenomena. We then discuss superconducting and normal systems. Finally, we discuss the difficult and controversial problem of decoherence and the mechanisms which govern it in nature. In this discussion the results of the Central Spin model are crucial- they describe the effect of a spin bath on a "qubit", or on a SQUID, or a magnetic macromolecule, which is trying to show coherent oscillations.

A. Magnetic Systems

(i) *Magnetic Solitons:* Magnetically ordered systems support a wide variety of soliton excitations, depending on the symmetry of the order parameter. These couple to various environmental excitations, which strongly affect their dynamics. These include both linear and non-linear couplings to "quasiparticle" excitations such as magnons^{24,72}, phonons²⁰, electrons⁷³, and photons⁷², all oscillator baths. More serious effects come from any localized modes

coupling to the soliton, most notably paramagnetic impurities and nuclear spins. Both of these can be understood theoretically using a model in which a moving particle couples to a spin bath²⁰, as in section 2.C.

Most experimental work in this area has looked at domain wall tunneling in ferromagnets. Early experiments looked at the dynamics of multi-wall systems^{83,84}. More recently attention has focussed on the tunneling of *single* domain walls, whose position can be monitored in various ways^{85–87}. These walls propagate along magnetic nanowires (of diameter 300-600 Å) and are thus mesoscopic objects (the material of choice is usually Ni, for which the domain wall thickness $\lambda_w \sim 700\text{Å}$). Although some predictions of the tunneling theory have been verified (eg., the square root dependence⁷² of the tunneling exponent on the pinning field H_c ; cf.^{84,85}), the crossover temperatures to tunneling are usually much higher than calculated values⁸⁵. A clue to the reason for this may be found in the microwave resonance experiments of Hong & Giordano⁸⁵, which show extremely broad resonances, even down to 1.5 K. The coupling to phonons or electrons is far too small to give this; however, Oxygen impurities, which will act as paramagnetic impurities, would act as a strong time-varying potential on any wall, and broaden the line²⁰. It is clear that much more experimental work will be necessary to really understand the quantum dynamics of magnetic domain walls.

(ii) *Magnetic Macromolecules*: On the other hand, a number of spectacular quantum effects have unquestionably been seen in crystalline arrays of magnetic macromolecules, in one of the most important developments in magnetism in recent years. Experiments on tunneling phenomena have had striking success in the "Mn-12" and "Fe-8" molecules (each of which behaves at low T as a "giant spin" of spin 10). There have also been highly-publicised experiments on the large "ferritin" molecule, which claim the observation of "macroscopic quantum coherence"; these are discussed in section 5.C below.

The early molecular work demonstrated resonant tunneling (coming when spin levels of each molecule are brought into resonance), at relatively high temperatures⁸⁸. More recent experiments^{34,36–40} have gone into the quantum regime, in which only the 2 lowest levels of each giant spin are occupied. The classical-quantum crossover is clearest in the case of the Fe-8 system (which is very conveniently described by the easy axis/easy plane model discussed in section 2.F); below a temperature $T_c \sim 0.4\text{ K}$, the dynamics is completely independent of T (the energy gap to the next spin level in this system is $\sim 5K$). In Mn-12 there are effects arising from "rogue" molecules which make things more complicated^{40,89}. At such low temperatures phonons are utterly irrelevant (experiments have now been pursued to $T \sim 30\text{ mK}$), and the only dynamic environment left is the nuclear spin bath. The system thus seems at first to be an ideal realisation of the central spin model discussed in sections 3 and 4. The main complication is that experiments are done on a crystalline array of molecules, which interact via strong magnetic dipolar interactions. However, once one knows that the dynamics of a single central spin is going to be incoherent relaxation (cf. sections 3.E, 4.A), these interactions are rather easy to deal with³⁵. The system is then described by an obvious generalisation of the central spin Hamiltonian, viz.

$$H = \sum_j H_j^{CS} + \sum_{ij} V(\mathbf{r}_i - \mathbf{r}_j) \hat{\tau}_i^z \hat{\tau}_j^z, \quad (5.1)$$

in zero applied field (compare eqtn. (2.30), without the oscillators). Here H_j^{CS} is the central spin Hamiltonian (2.16) for the molecule at lattice position \mathbf{r}_j , and $V(\mathbf{r}_i - \mathbf{r}_j)$ is the magnetic dipolar coupling between molecules i and j .

To solve for the dynamics of such an interacting array of systems, one begins³⁵ by defining a distribution function $P_\alpha(\xi, \mathbf{r}, t)$ for a molecule at position \mathbf{r} to be in a longitudinal bias ξ , with polarisation $\tau_z = \alpha = \pm 1$. It is then trivial to write down a BBGKY-like hierarchy of kinetic equations for $P_\alpha(\xi, \mathbf{r}, t)$ and its multimolecular generalisations $P^{(2)}(1, 2) \equiv P_{\alpha_1, \alpha_2}^{(2)}(\xi_1, \xi_2; \vec{r}_1, \vec{r}_2; t)$, and $P^{(3)}(1, 2, 3)$, etc., of which the first member is

$$\begin{aligned} \dot{P}_\alpha(\xi, \vec{r}) = & -\tau_N^{-1}(\xi) [P_\alpha(\xi, \vec{r}) - P_{-\alpha}(\xi, \vec{r})] \\ & - \sum_{\alpha'} \int \frac{d\vec{r}'}{\Omega_0} \int \frac{d\xi'}{\tau_N(\xi')} \left[P_{\alpha\alpha'}^{(2)}(\xi, \xi'; \vec{r}, \vec{r}') - P_{\alpha\alpha'}^{(2)}(\xi - \alpha\alpha'V(\vec{r} - \vec{r}'), \xi'; \vec{r}, \vec{r}') \right], \end{aligned} \quad (5.2)$$

in which relaxation is driven by the nuclear spin-mediated relaxation rate $\tau_N^{-1}(\xi) \sim (\Delta^2/\tilde{\Gamma})e^{-|\xi|/\xi_0}$ (cf eqtn (3.45), in conjunction with the dipolar interactions. Under general conditions we must also solve for $P^{(2)}$ in terms of $P^{(3)}$, etc.; but if the initial experimental state is either *polarised* or *annealed* then $P^{(2)}$ factorises at $t = 0$ (ie., $P^{(2)}(1, 2) = P(1)P(2)$), and (5.2) can be solved. This led to the following predictions^{9,35}:

i) Relaxation should only occur for molecules having $|\xi| \leq \xi_0$; consequently a "hole" rapidly appears in $M(\xi, t) = P_+(\xi, t) - P_-(\xi, t)$ with time, with initial width ξ_0 determined entirely by the nuclear dynamics (and of course typically $\xi_0 \gg \Delta$). In fact microscopic calculations of ξ_0 for the Fe-8 molecule^{69,70} can be done (recall Fig. 5(b)), since the hyperfine couplings are essentially dipolar (the relevant nuclei include 120 protons, 8 Br nuclei, and 18 N nuclei). One finds that even the weak molecular dipolar fields strongly distort the hyperfine fields, mixing up the different

polarisation groups, and also giving a large value of κ . The final value ξ_o will obviously depend sensitively on any nuclear isotopic substitution^{69,70}. The subsequent evolution of the hole depends on sample shape; this has been studied theoretically using Monte Carlo simulations³⁵.

(ii) The short-time relaxation for the total magnetisation $M(t) = \int d\xi M(\xi, t)$ should have a "square-root" time form

$$M(H_0, t) = M_0[1 - (t/\tau_Q(H_0))^{1/2}], \quad (5.3)$$

where M_0 is the initial magnetization (or with appropriate modifications for other protocols, such as a zero-field cooling followed by relaxation in a field^{38,40}), and $\tau_Q^{-1}(H_0) = c(\xi_o/E_D)\Delta^2 M(\xi = -g\mu_B S H_0, t = 0)$, where W_D^{-1} is the "density of states" of the distribution. The constant c is dimensionless, depending on sample shape, and can be evaluated analytically or numerically. Notice that the existence of the square root does not depend on sample shape, and indeed its persistence over fractional relaxations of ~ 0.1 is clearly demonstrated in Monte Carlo simulations for different shapes^{35,36,90}.

This result implies that by varying H_0 , one can measure $M(\xi)$, by extracting $\tau_Q^{-1}(H_0)$ at successive values of H_0 . If one knows $M(\xi)$ (as one does in an annealed sample - it should be Gaussian) then one may then extract Δ from measurements of τ_Q^{-1} . The \sqrt{t} dependence of $M(t)$ has since been reported in quite a few experiments, on both Fe(8) crystals^{36,38,39} and Mn(12) crystals³⁷ (although the situation in Mn-12 is seriously complicated by "impurities"⁴⁰). The Fe-8 experiments have produced remarkable "maps" of $M(\xi)$, and its time variation^{36,38}. The "hole-digging" has been found in both Fe-8 and Mn-12^{38,40}, with an "intrinsic" short-time intrinsic linewidth which is roughly that expected from the hyperfine interactions, provided one takes account of the effect of internal fields⁷⁰, which make T_1 very short (so that κ is effectively $\sim \sqrt{N}$).

Wernsdorfer et al³⁸ also used this technique to extract the value of Δ for Fe-8. In a remarkable experiment, Wernsdorfer and Sessoli³⁹ extended these measurements of Δ to include a *transverse* applied field H_\perp ; as noted in section 2.F, the topological giant spin phase Φ should vary with field H_\perp ^{77,76}, producing Aharonov-Bohm oscillations in $\Delta(H_\perp)$. These oscillations were found, both as oscillations in the relaxation rate $\tau_Q^{-1}(H_\perp)$, and using a quite different AC absorption ("Landau-Zener") technique; these independent techniques agreed rather well in the measurement of Δ . Notice, incidentally, that neither method can properly measure Δ near its nodes (ie., where $\Delta \rightarrow 0$); this is because of the distribution of internal transverse fields. Incidentally, we should strongly emphasize that these experiments (even the Aharonov-Bohm ones) do *not* demonstrate coherent tunneling- indeed they show exactly the opposite! This is because the experiments are inherently *relaxational* (this is why all rates are $\sim |\Delta|^2$, and not $\sim \Delta$). Readers puzzled about how an Aharonov-Bohm effect can occur in a relaxation rate, are encouraged to think about other examples in physics where phase interference shows up in irreversible quantum phenomena. In the present case we may loosely define a "decoherence time" τ_ϕ for the molecular spins (one should not push this too far, given the non-exponential nature of the central spin relaxation!), and one finds that $\tau_\phi \Delta_o \ll 1$ (no coherent oscillations possible) but $\tau_\phi \Omega_o \gg 1$ (ie., coherence is maintained during a single very rapid tunneling transition).

In a very recent experiment⁹¹, deliberate modification of the nuclear isotopes in an Fe-8 crystal has shown a dramatic modification of the bulk magnetic relaxation- this is the most direct evidence so far for the role of the nuclear spins in mediating the quantum relaxation. It will be interesting to see a quantitative comparison with the calculated results for different isotopes^{69,70}.

(iii) *Quantum Spin Glasses*: The work on nanomagnets probes our understanding of collective phenomena in many magnetic systems, ranging from spin chains to quantum spin glasses. This latter example is very closely related to the molecular nanomagnets just described, since the model Hamiltonian is just (5.1), with the dipolar interaction replaced by a set $\{J_{ij}\}$ of "frustrating" interactions, usually long-ranged. A typical experimental example is provided by the disordered dipolar spin system $\text{LiHo}_x\text{Y}_{1-x}\text{F}_4$ (where the Ho moments interact via dipolar interactions⁹², and the Δ are induced by a transverse field). Until now most theory has ignored the environment in this problem, but from our discussion above, this is clearly a mistake if one wishes to discuss dynamics. This is also the view expressed in recent papers of Cugliandolo et al.³⁰, who have included coupling to an oscillator bath environment. This is presumably correct in metallic glasses, where the coupling to electrons dominates (compare the discussion following (2.8)), but in insulators the coupling to nuclear spins dominates (in $\text{Li}_{1-x}\text{Ho}_x\text{F}_4$ this is clear- the hyperfine coupling even modifies the phase diagram!). An observation of strong hole-digging in $M(\xi, t)$ in a spin glass would be consistent with this, since oscillator baths typically give most rapid relaxation *away* from resonance (*cf.* discussion after eqtn. (3.45)). Note also that one of the main theoretical questions concerning quantum spin glasses, viz., what happens when $\Delta \sim J_{ij}$, could be examined experimentally using molecular magnets like Fe-8, or the $\text{LiHo}_x\text{Y}_{1-x}\text{F}_4$ system, in a strong transverse field, where one might reasonably expect to see coherent propagation of tunneling events from one site to another if Δ is sufficiently large.

B. Conductors and Superconductors

In mesoscopic conductors the standard weak localisation theory⁹³ evaluates a "decoherence time" $\tau_\phi(T)$ in terms of the electron-electron scattering rate, which is itself strongly influenced at low T by elastic impurity scattering. This is essentially an oscillator bath problem- the relevant oscillators being diffusons, Cooperons, and phonons. Curiously, given the known importance of scattering off dynamic "2-level" fluctuators in these systems⁵², there has been little theory on the effect of these on τ_ϕ , apart from the pioneering work of Altshuler and Spivak, and Feng et al.⁹⁴. This is of course a spin bath problem, with the spins representing defects, paramagnetic impurities, etc., in the environment. It will be interesting to see if the "saturation" in $\tau_\phi(T)$ reported at low T ⁵³ may at least be partially explained by such scattering. The physics of this saturation depends on the more fundamental question of how decoherence behaves in the low- T limit in conductors, and has caused considerable debate in the recent theoretical literature^{53,95}.

In the case of superconductors the situation is similar, in that almost all theoretical work on dissipation and other environmental effects has looked at the effects of electronic quasiparticle modes or photons, ie., delocalised modes which can be mapped directly to oscillator modes. The pioneering papers^{10,12,47,54} led to a massive subsequent literature, both experimental⁴¹⁻⁴⁴ and theoretical^{22,46}. In most work on tunneling there is no question that theory and experiment correspond very well⁴³. However the situation is more delicate for coherence, discussed below. In spite of the extensive theory of spin impurity effects in superconductors we are aware of only 2 theoretical papers^{17,19} (and no experiments) examining their effect on the flux dynamics (in particular tunneling) of SQUIDs.

C. Coherence and decoherence; and "qubits"

An understanding of decoherence mechanisms is central to the exploitation of mesoscopic systems in quantum devices, as well as to general questions about how quantum mechanics applies on the large scale,^{68,96} and the quantum measurement problem²⁸. It has become particularly important now that efforts are being made to construct "qubit" devices, with a view to making quantum computers.

The last 15 years have seen a total transformation in how such questions are discussed- instead of vague analyses in terms of "measurements" by the environment, we now have precise and generally applicable models, which can be tested in many experiments. The basic issues are (i) whether phase coherence can be preserved in the reduced density matrix of the system of interest and (ii) what are the decoherence mechanisms destroying it. Here we briefly review studies of superconducting and magnetic systems, and then examine things from a more general theoretical standpoint.

(i) *Decoherence in superconductors*: This has been discussed intensively ever since the theoretical predictions of Leggett et al.^{10,68} concerning "macroscopic quantum coherence" in SQUIDs, and subsequent proposals for experimental searches⁹⁷. To date no experimental success has been reported (although there is good evidence for resonant "one passage" tunneling transitions between near degenerate levels in 2 wells^{44,45}). Almost all microscopic analyses of this problem have assumed environments of electronic excitations which can be mapped onto oscillator baths (see, eg.,^{22,47,68,46}). In our opinion, as discussed in section 4.B, the basic problem is simply that the main source of decoherence in most systems (including SQUIDs) at low T will not be any oscillator bath, but the spin bath of paramagnetic and nuclear spins. As discussed in section 2.G and 4.B, the low-energy scale of this spin bath means it will not usually have a big effect on SQUID tunneling, but its effect on macroscopic coherence or on superconducting qubits will be rather large.

Although a superconducting qubit has not yet been built, experiments may be getting rather close⁴⁵. To see how big spin bath effects on coherence might be, let us recall that the effect of paramagnetic impurities is to create a Gaussian multiplet of spin bath states of width $E_o \sim \mu_B B_o \sqrt{N_{pm}}$ in energy for a SQUID containing a total of N_{pm} paramagnetic impurities interacting with the supercurrent, where B_o is the change in field on each paramagnetic impurity caused by the change in flux state of the SQUID. To see coherence it is necessary, from the discussion of section 4.B, that $\Delta_o \gg E_o$, because the decoherence time coming from the spin bath is $\tau_\phi \sim \Delta_o/E_o^2$; this essentially sets a lower bound for Δ_o . As discussed in some detail in a recent paper⁷⁸, this turns out to be a rather stringent requirement on real SQUIDs; in fact in the experiments of the Lukens group⁴⁴ one infers a value $E_o \sim 0.4 K$ from their resonant linewidths. Obviously this value could be reduced a great deal by careful attention to the nuclear and paramagnetic spin impurity composition in the system (as well as to the sample geometry).

(ii) *Decoherence in Magnets*: The most dramatic claims for the observation of macroscopic coherence have been made by Awschalom et al.⁹⁹, working on randomly oriented dilute ensembles of ferritin macromolecules (which order antiferromagnetically, but carry an excess moment of somewhat random size; the antiferromagnetic "Néel" moment is $\sim 23,000 \mu_B$). In an effort to make the molecule size as uniform as possible, these authors filtered them magnetically.

They also artificially engineered molecules of smaller size. The essential result was the observation of an absorption peak at MHz frequencies, whose frequency varies approximately exponentially with the size of the molecules. This was interpreted as a signature of coherent tunneling between "up" and "down" states of the Neel vector. There have been widespread objections to this interpretation, both on theoretical and experimental grounds¹⁰⁰, and so far no other group has succeeded in confirming the experiments. Note that the Awschalom group saw similar resonances (also with an exponential dependence of resonant frequency on size) in large $FeCo_5$ particles, but did *not* attribute this to tunneling¹⁰¹.

As we discussed in the previous sub-section, there is now very extensive evidence that nanomagnetic molecules in macroscopically ordered crystals tunnel *incoherently* in the low- T quantum regime^{34,36-40}. There is thus an apparent contradiction between the ferritin work and that done in the Mn-12 and Fe-8 systems (particularly since the ferritin molecules are much larger and certainly contain a lot of spin disorder). Thus in the very well-characterised $Fe-8$ molecular crystals used by the Florence and Grenoble groups, the parameter κ characterising decoherence from the orthogonality blocking mechanism varies^{69,70}, even in an ideal sample, between $\kappa \sim 6 - 15$ in zero applied field (depending on the annealing-dependent spread W_D in the intermolecular dipolar fields), to $\kappa \sim 80$ when $H_x \sim 0.2 T$ (where the first zero in Δ is supposed to occur⁴⁰). Recalling from sections 3.C and 4.A that coherence is practically eliminated unless $\kappa \ll 1$, it is hard to see how experiments on these particular molecules in low fields will stand much chance of seeing it.

On the other hand it is clear that future experiments on *single* nanomagnets in the quantum regime might have a chance of seeing coherence *iff* one could raise Δ_o to values \gg the hyperfine couplings ω_k (presumably using a large external transverse field), thereby making $\kappa \ll 1$ and so removing decoherence (and also reducing the problem to a straightforward spin-boson model- see section 4.B). Another possibility, which could be realised in, eg., the $LiHo_xY_{1-x}F_4$ system at high transverse fields, would be to see coherent propagation of spin flips (ie., spin waves) in a lattice of spins, by making $\Delta > W_D$ (here one could also make $\omega_k \gg kT$, thereby *freezing* the nuclear dynamics!). Conceivably the same could be done in an $Fe-8$ crystal (now with the inequality $\Delta > W_D \gg \omega_k$ operating). We see no reason why such experiments could not be done in the next few years.

(iii) *Decoherence as $T \rightarrow 0$* : Let us now consider the general question of decoherence effects at low T . Decoherence is often (particularly in conductors) characterised by a "decoherence time" τ_ϕ , for the phase dynamics of the degree of freedom of interest. If and when τ_ϕ is meaningful, it may be much shorter than the energy relaxation time τ_E (cf. the example of a single oscillator coupled to an oscillator bath⁹⁸, or the examples of topological decoherence given for the spin bath in sections 3.A and 4.A above)). Coherence exists if $\tau_\phi \Delta_o \ll 1$, where Δ_o is the characteristic frequency of the system's phase dynamics.

Notice that what allows us to discuss this problem with any generality at all is the assumption, discussed in sections 1 and 2, that a few canonical models describe the low- T behaviour of most physical systems. Extensive study of the relevant canonical oscillator bath models (in particular, the spin-boson model^{10,11,68} and the "oscillator on oscillators" model^{12,61}) show that with a power-law form $J(\omega) \sim \omega^n$, decoherence disappears as $T = 0$ for $n > 1$; for the Ohmic form $J(\omega) = \pi\alpha\omega$ decoherence is finite at $T = 0$, but can be made small if $\alpha \ll 1$. If the electronic spectrum is gapped the Ohmic dissipation falls off exponentially in the low T limit (thus for superconductors^{47,46} one has $J(\omega, T) \sim \omega e^{-\Delta_{BCS}/kT}$ for $\omega < 2\Delta_{BCS}$, and for magnetic solitons^{24,72,20} one has $J(\omega, T) \sim \omega(kT/\Delta_m)e^{-\Delta_m/kT}$ for $\omega < 3\Delta_m$, where Δ_{BCS} and Δ_m are the BCS and magnon gaps respectively). Thus, if one believes the oscillator bath models, coherence ought to be easily observable at low T ; the condition $\tau_\phi(T)\Delta_o \ll 1$ is clearly satisfied for temperatures well below the gap energy.

If we examine the canonical spin bath models we find a very different story⁵⁻⁹. Consider first the central spin model as $T \rightarrow 0$; we will go to such a low temperature that all of the spins in the spin bath order in the field of the central spin (ie., $T \sim 1\mu K$ in some cases), ie., all intrinsic fluctuational dynamics of the bath is frozen out. Does decoherence disappear? No, because the mechanisms of topological decoherence (induced bath spin flip) and orthogonality blocking (precession of the bath spins in between central spin flips) still exist- the bath can still acquire dynamics from the central spin. We emphasize here that this physics cannot be described by an oscillator bath model. From the results in section 4 we see there is a residual constant decoherence as $T \rightarrow 0$, coming from the spin bath, which in an experiment would be signalled by a saturation of τ_ϕ once oscillator bath effects had disappeared. The extent of this decoherence is characterised by the behaviour of $P_{M=0}(t)$, (cf. section 4.A), and we saw that unless both κ and λ were $\ll 1$, decoherence was strong. In the case where all bath spins are polarised by the central spin, transitions are blocked anyway- there are no spins in the $M = 0$ polarisation group!

We conclude that for any system described by the central spin model (ie., where the central system reduces to a 2-level system at low energies), a general consequence of the coupling to a spin bath will be a loss of coherence, via either the topological decoherence or orthogonality blocking mechanisms, even in the $T \rightarrow 0$ limit. The residual coherence (if any) will depend on the strength of the couplings to the spin bath, in a way discussed quantitatively in sections 4 and 5.

We may generalise these considerations to models in which a "particle" moves through a spin bath (the same model also describes a network of spins, or of mesoscopic superconductors, etc., coupled to a spin bath), and get the same result. Consider, eg., a particle hopping from site to site on a D -dimensional hypercubic lattice, whilst coupled to a spin bath¹⁰², and described by a Hamiltonian

$$H^{latt}(\Omega_o) = \Delta_o \left\{ \sum_{\langle ij \rangle} \left[c_i^\dagger c_j \cos[\Phi_{ij} + \sum_k \vec{V}_k^{ij} \cdot \vec{\sigma}_k] + H.c. \right] + \sum_k \left[\omega_k^{ij} (c_i^\dagger c_i - c_j^\dagger c_j) \vec{\sigma}_k^z + \omega_k^\perp \hat{\sigma}_k^x \right] \right\} + \sum_{k,k'} V_{kk'}^{\alpha\beta} \hat{\sigma}_k^\alpha \hat{\sigma}_{k'}^\beta ; \quad (5.4)$$

where $\langle ij \rangle$ sums over nearest neighbour sites. The couplings ω_k^{ij} and \vec{V}_k^{ij} to the bath spin $\vec{\sigma}_k$ usually depend upon which "lattice rung" (i, j) the particle happens to be, because the coupling normally has a finite range and the spin $\vec{\sigma}_k$ has some position with respect to the lattice (one can also add a longitudinal coupling to the $\{\hat{\sigma}_k^z\}$ on each site, as in eqtn. (2.30)). In the continuum limit (5.4) reduces to (2.11) and (2.12), after dropping the external field \vec{h}_k and the dependence of $F_k^\perp(P, Q)$ on Q . To isolate the decoherence effects let us assume $V_{kk'} = 0$, ie., we now study the analogue of the strong-coupling regime in section 4.A. Without loss of generality we may then concentrate on the "phase decoherence" regime, ie., on an effective Hamiltonian $H_{eff} = \sum_M w_M H_M^{eff}$, where

$$H_M^{eff} = \Delta_o \sum_{\langle ij \rangle} [c_i^\dagger c_j \hat{\mathcal{P}}_M e^{-i \sum_k \alpha_k \hat{\sigma}_k} \hat{\mathcal{P}}_M + H.c.] \quad (5.5)$$

This is just a generalisation of (4.5) to the lattice; the dependence of the coupling on the lattice position is dropped because it is inessential to what follows.

Coherence, if it exists, will appear in the function $P_{n0}(t)$ (the probability to start at site 0, and be at site n a time t later). Perfect coherence (ie., no bath) yields

$$P_{\vec{n}0}^{(0)}(t) = \sum_{\vec{p}, \vec{p}'} e^{i[(\vec{p}-\vec{p}') \cdot \vec{n} - (E_{\vec{p}} - E_{\vec{p}'})t]} = \prod_{\mu=1}^D J_{n_\mu}^2(2\Delta_o t) \quad (5.6)$$

for which $P_{00}^{(0)}(t) \sim 1/(\Delta_o t)^D$ at long times; moreover, the 2nd moment $\langle (n(t)^2) = \sum_{\vec{n}} n^2 P_{\vec{n}0}^{(0)}(t) \sim D(\Delta_o t)^2$ at long times. Both are characteristic of coherent "ballistic" band motion.

If we now go to the interacting case one finds, by a straightforward generalisation of the calculations in sections 3 and 4, some rather interesting results¹⁰². Consider first a bath with all spin states equally populated. Then at long times $\langle (n(t)^2) \rightarrow D(\Delta_o t)^2$ but $P_{00}^{(0)}(t) \rightarrow (1/\Delta_o t)$, independent of D ! Moreover, if we start with an initial Gaussian wave-packet of width $\Delta n(t=0) = R_o$, one finds $P_{00}^{(0)}(t) \rightarrow (1/R_o \Delta_o t)$ as $t \rightarrow \infty$. These results show that the naive inference of ballistic propagation from the second moment result is wrong- in reality one has strongly anomalous diffusion (with an energy-dependent diffusion coefficient, demonstrated by the R_o -dependence of the results). In fact the probability function $P_{\vec{n}0}^{R_o}(t)$ decays like $R_o/(\Delta_o t) |\vec{n}|^{(D-1)}$ at long times (ie., $\Delta_o t \gg R_o$) and distances $|\vec{n}| \gg R_o$, out to a "ballistic" distance $l(t) \sim \Delta_o t$, for dimension $D > 1$. Thus there is an advance "ballistic front" which decays in amplitude with increasing distance/time from the origin, but only as a power law; and it is followed by a much larger anomalously diffusive (and of course incoherent) contribution. For sufficiently long times (in fact for $\lambda \Delta_o t \gg 1$) this result is independent of λ . Similar results apply for the orthogonality-blocked case as a function of κ .

Now let's take the limit $T \rightarrow 0$, meaning that we allow the bath spins to order in the field of the particle. It is clear that if $\omega_k^\parallel \gg \Delta_o$ for all spins, and provided there are no non-diagonal momentum couplings to the bath, we cannot get decoherence by the same mechanism as above, since there is only one state in the relevant polarisation group- the particle will then move freely without disturbing the spins in any way. However in any other case phase will be exchanged with the bath in the same way as above, with or without dissipation (which will certainly arise in the weak-coupling limit $\omega_k^\parallel < \Delta_o$).

We therefore conclude that a finite decoherence in the $T \rightarrow 0$ limit is a generic consequence of the existence of spin bath environments.

(iv) *Qubits and Quantum Computation*: What is the impact of these results on hopes for quantum computation? A Quantum computer is an information processing device which can be imagined as an assembly of 2-state qubits, these being none other than the spin-boson and Central spin models discussed in this article^{104,105}. Such a computer has yet to be built, and papers and books on this topic tend to divide into 2 classes. The first simply ignores

decoherence (apart from occasionally referring to it as the main stumbling block preventing the construction of a quantum computer!), whereas the second regards decoherence as the crucial problem, and either tries to treat it theoretically (eg.,¹⁰⁶) or maintains that a quantum computer will never be built because of it (eg.,¹⁰⁷).

The basic problem here is the lack of serious theory on the effects of decoherence, starting from realistic models which can be tested quantitatively by experiment. The analysis of the Central Spin model in sections 3 and 4 can be used for a single qubit- it will be clear that the main task is to reduce diagonal couplings to the spin bath (and also any oscillator bath) as far as possible. However this is only the beginning of the problem- the operation of a quantum computer involves multi-qubit wave-function entanglement, and thus one wants to understand the behaviour of a decoherence time $\tau_\phi^{(M)}(\xi_1, \xi_2, \dots, \xi_M)$, governing loss of M -spin phase correlations, in the presence of coupling to spin and oscillator baths. We are aware of no studies of this problem (or even recognition that it is a problem) in the literature. Studies of mutual coherence and decoherence in the problem of 2 spins coupled to an oscillator bath²⁰ give some feeling for what might happen, as do the studies of lattice systems. However we still have no answer to, for example, the question of how $\tau_\phi^{(M)}$ behaves for large M . If it ends up having a generic decrease $\sim e^{-aM}$ then the whole quantum computing enterprise will be in very serious trouble!

It is clear that in the near future research on quantum computers will have to proceed on both practical designs (with serious attention given to the decoherence characteristics of the relevant materials), and also on general studies of decoherence for systems of coupled qubits, themselves coupled to spin and oscillator baths. This promises to be one of the great challenges in condensed matter physics during the next decade.

VI. ACKNOWLEDGEMENTS

We would like to thank NSERC and the CIAR in Canada, and the Russian Foundation for Basic Research (grant 97-02-16548) and European Community (grant INTAS-2124), for financial support of our research. We also thank I. Affleck, Y. Aharonov, B. Barbara, J. Clarke, M. Dubé, W. Hardy, A.J.Leggett, T. Ohm, C. Paulsen, R. Penrose, G. Rose, I.Tupitsyn, W.G. Unruh, I.D. Vagner, and W. Wernsdorfer for helpful discussions about the spin bath, going back to 1987.

VII. NOTE ADDED IN PROOF (FEB 22, 2000)

A number of papers touching upon the present subject (particularly on decoherence) have appeared since this article was written.

On the highly controversial question of zero-temperature decoherence in mesoscopic conductors^{53,95} (which according to some authors throws the entire conventional theory of metals into doubt), a large number of suggestions have appeared. A list of them appears in a short experimental review by Mohanty¹⁰⁸, which concludes that only the original suggestion, of electronic coupling to zero-point fluctuations of the EM field^{53,95,109}, can explain the experimental saturation of τ_ϕ . This conclusion is hotly disputed by other authors, both on experimental and theoretical grounds^{110,111}. The idea that the decoherence might be coming from "two-level systems" in the sample (ie., from a spin bath) has been explored by Imry et al.¹¹² and Zawadowski et al.¹¹³, but rejected by Mohanty, mainly because it would imply very large low-frequency noise levels in the sample. In our opinion this requires further work- some of the decoherence mechanisms discussed in the present article do not appear in these papers, and would not necessarily show up in the low-frequency noise. In any case this controversy shows clearly how the theory of transport, including weak localisation theory, depends crucially on a correct understanding of decoherence mechanisms.

The most interesting recent experimental progress concerning the mechanisms of decoherence may be work in magnetic systems. The most recent work by Wernsdorfer et al.⁹¹, which looked at the dependence of tunneling rates and "hole widths" in the resonant quantum relaxation of crystals of $Fe-8$ molecules, has been supplemented by further work on the same system¹¹⁴. Taken together these experiments give rather strong evidence that the tunneling is mediated and controlled by the nuclear spins in the system. No direct test has yet appeared of the theory of the decoherence coming from these same nuclear spins, however (which depends on calculations of the parameter κ ; cf. section 2.6, including Fig. 5, and sections 3.3, 4.1, 5.1, and 5.3, including Fig. 8, and refs.^{69,70}). Experiments looking for coherence in $Fe-8$ have also been done at higher fields¹¹⁵; however we are unable to see why the reported results give evidence either for or against coherence, since they simply show very broad and rather weak peaks in the ESR spectrum as a function of field. We emphasize a point here which has often been made, viz., that any demonstration of coherence requires direct observation of combinations of multi-time correlation functions- even a very sharp peak in, say, the AC absorption is not enough to demonstrate coherence. In this connection the reader is referred to Figs. 7-9 in the present paper, which show peaks in $\chi''(\omega)$ even when there is no coherence at all. Several reviews of the many

different experiments in tunneling nanomagnets have also recently appeared^{116–118}. One topic not covered in these is the $\text{LiHo}_x\text{Y}_{1-x}\text{F}_4$ system (section 5.1.3); some interesting new results on this compare the thermal and quantum annealing, showing the efficiency of the latter in quantum optimisation¹¹⁹.

More general discussions of coherence and decoherence appearing recently include several theoretical reviews^{120–124} (although these do not really discuss spin bath environments). There has also been interesting experimental work on systems other than superconductors and magnets; see, eg., Wiseman et al.¹²⁵ for coupled quantum dots, and Myatt et al.¹²⁶ for decoherence in quantum optical systems.

APPENDIX A: DERIVATIONS FOR LIMITING CASES

In this appendix we give the derivations of some key formulae in sections 3 and 4. Instanton methods are used to handle the spin environment. In Appendix A.1 we give details of the fairly trivial calculations required to deal with averaging over bias, topological phase, and fluctuations in bias. Then in Appendix A.2 we discuss the more lengthy derivation of the expression (3.21) involved in orthogonality blocking.

1. Topological phase, bias, and bias fluctuation effects

We wish to evaluate $P_{11}(t)$, the probability for the central spin to return to an initial state $|\uparrow\rangle$ after time t , in the presence of a static bias ξ and a noisy bias $\epsilon(t)$. We use ssh physics.ubc.ca standard instanton techniques^{10,103}, because they easily generalise to include the spin bath.

We begin by ignoring the topological phase of the central spin since its effects are trivial to add. Then the amplitude for a 2-level system to flip in a time dt is $i\Delta_o dt$, and the return probability is given by summing over even numbers of flips:

$$P_{11}^o(t) = \frac{1}{2} \left\{ 1 + \sum_{s=0}^{\infty} \frac{(2i\Delta_o t)^{2s}}{(2s)!} \right\} = \frac{1}{2} [1 + \cos(2\Delta_o t)], \quad (\text{A1})$$

Now consider the modification introduced by a *longitudinal* static bias ξ . In instanton language we begin with the return *amplitude* $A_{11}(t, \xi)$, and Laplace transform it; using the action $e^{\pm i\xi dt}$ in bias ξ , over time dt , we get

$$A_{11}(t, \xi) = \sum_{n=0}^{\infty} (-i\Delta_o)^{2n} \int_0^t dt_{2n} \dots \int_0^{t_2} dt_1 e^{i(\xi(t-t_{2n}) - \xi(t_{2n}-t_{2n-1}) + \dots + \xi t_1)} = \int_{-i\infty}^{i\infty} e^{pt} A_{11}^{TLS}(p, \xi), \quad (\text{A2})$$

$$A_{11}^{TLS}(p, \xi) = \frac{1}{p - i\xi} \sum_{n=0}^{\infty} \left(\frac{(-i\Delta_o)^2}{p^2 + \xi^2} \right)^n = \frac{1}{p - i\xi} \frac{p^2 + \xi^2}{p^2 + E_o^2}. \quad (\text{A3})$$

where $E_o = [\xi^2 + \Delta_o^2]^{1/2}$; then the standard answer for $P_{11}(t, \xi)$ is just:

$$\begin{aligned} P_{11}(t, \xi) &= \int_{-i\infty}^{i\infty} dp_1 dp_2 \frac{e^{(p_1+p_2)t}}{(p_1 - i\xi)(p_2 - i\xi)} \sum_{n=0}^{\infty} \sum_{m=0}^{\infty} \left(\frac{(-i\Delta_o)^2}{p_1^2 + \xi^2} \right)^n \left(\frac{(-i\Delta_o)^2}{p_2^2 + \xi^2} \right)^m \\ &= [1 - \frac{\Delta_o^2}{2E^2} (1 - \cos 2Et)] = [1 - \frac{\Delta_o^2}{E^2} \sin^2 Et] \end{aligned} \quad (\text{A4})$$

This representation avoids the difficulty in the usual representation coming from the square root $E = [\xi^2 + \Delta_o^2]^{1/2}$ in the cosine.

We now add a fluctuating bias $\epsilon(t)$ to ξ , with the correlation $\langle [\epsilon(t) - \epsilon(t')]^2 \rangle = \Lambda^3 |t - t'|$ for short times. Noise averages are then given by the Gaussian average

$$\langle F[\epsilon(t)] \rangle = \int \mathcal{D}\epsilon(t) F[\epsilon] e^{-\frac{1}{2} \int dt_1 \int dt_2 \epsilon(t_1) K(t_1 - t_2) \epsilon(t_2)} \quad (\text{A5})$$

with a noise correlator $2K^{-1}(t_1 - t_2) = \Lambda^3 (|t_1| + |t_2| - |t_1 - t_2|)$. Averaging over a phase function $F(t_1, t_2) = e^{i \int_{t_1}^{t_2} ds \epsilon(s)}$ then gives the standard result

$$\langle F(t_1, t_2) \rangle = e^{i\epsilon(t_1)(t_2-t_1)} e^{-\Lambda^3(t_2-t_1)^3/6}, \quad (\text{A6})$$

In applying this to (A2) we assume fast diffusion (see text), and thus only expand to $\sim O(\Delta^2)$. This gives $P_{11}(t) = e^{-t/\tau(\xi)}$, with

$$\tau^{-1}(\xi) = 2\Delta^2 \int d\epsilon G_\mu(\epsilon) \int_0^\infty ds e^{i(\epsilon+\xi)s} e^{-\Lambda^3 s^3/6} = 2\pi^{1/2} \frac{\Delta^2}{\Gamma} e^{-(\xi/\Gamma)^2} \quad (\text{A7})$$

where $G(\epsilon) = (2/\pi\Gamma^2)^{1/2} e^{-2(\epsilon/\Gamma)^2}$ is the probability $\epsilon(t)$ takes value ϵ (ie., it is the lineshape of the polarisation group).

Adding the the topological phase $\Phi_o = \pi S$ to these calculations changes the flip amplitude to $i\Delta_o \exp\{\pm i\Phi_o\} dt$; one then sums over all paths with an even number of flips *and* over all combinations of \pm (clockwise and counterclockwise) flips; thus (A1) becomes

$$P_{11}^{(0)}(t) = \frac{1}{2} \left\{ 1 + \sum_{s=0}^{\infty} \frac{(2i\Delta_o t)^{2s}}{(2s)!} \sum_{n=0}^{2s} \frac{(2s)!}{(2s-n)!n!} e^{i\Phi_o(2s-2n)} \right\} = \frac{1}{2} [1 + \cos(4\Delta_o \cos \Phi_o t)], \quad (\text{A8})$$

with similar obvious modifications to include bias. The generalization to include the phase from the bath spins (topological decoherence) is now obvious for both imaginary and full complex α_k (see text, section 3.A).

2. Orthogonality blocking effects

We consider the situation described in section IV.B., where the "initial" and "final" fields on the bath spin $\vec{\sigma}_k$ are $\vec{\gamma}_k^{(1)}$ and $\vec{\gamma}_k^{(2)}$, related by an angle β_k , which is assumed small, and is defined by $\cos 2\beta_k = -\vec{\gamma}_k^{(1)} \cdot \vec{\gamma}_k^{(2)} / |\vec{\gamma}_k^{(1)}| |\vec{\gamma}_k^{(2)}|$. We choose axes in spin space such that the initial and final spin bath wave-functions are related by

$$| \{ \vec{\sigma}_k^f \} \rangle = \prod_{k=1}^N \hat{U}_k | \{ \vec{\sigma}_k^{in} \} \rangle = \hat{U} | \{ \vec{\sigma}_k^{in} \} \rangle. \quad (\text{A9})$$

where $\hat{U}_k = e^{-i\beta_k \hat{\sigma}_k^z}$ (compare eqtn. (3.19)).

In general the initial spin bath state will belong to some polarisation group M_o (not necessarily $M_o = 0$), where the polarisation is defined along some direction defined by the central system (for example, in a nanomagnetic problem, one could define it as the direction of initial orientation of the nanomagnetic spin). As explained in the text, during a central system transition energy conservation requires the polarisation to change from M_o to $M_o - 2M$ (and back, for further transitions); for "pure" orthogonality blocking (ie., when no other terms are involved in the Hamiltonian), $M_o = M$. In what follows we calculate the correlation function $P_{M_o, M}(t)$, the central spin correlator defined under the restriction that the spin bath transitions are between subspaces defined by $\langle \hat{\mathcal{P}} \rangle \equiv \langle \sum_{k=1}^N \hat{\sigma}_k^z \rangle = M_o$ and $\langle \hat{\mathcal{P}} \rangle = M_o - 2M$ subspaces, which are supposed to be in resonance. The statistical weight of states with $M_o > N^{1/2}$ is negligible, so we will assume that $M_o, M < N$.

We enforce the restriction to a polarisation group M using the projection operator

$$\hat{\Pi}_M = \delta \left(\sum_{k=1}^N \hat{\sigma}_k^z - M \right) = \int_0^{2\pi} \frac{d\xi}{2\pi} e^{i\xi \left(\sum_{k=1}^N \hat{\sigma}_k^z - M \right)}. \quad (\text{A10})$$

We can now write down an expression for the *amplitude* (not the probability!) $A_{M_o, M}^{11}(t)$ for the central spin $\vec{\tau}$ to stay in state $|\uparrow\rangle$ during a time t :

$$A_{M_o, M}^{11}(t) = \left\{ \sum_{n=0}^{\infty} \frac{(i\Delta_o(\Phi)t)^{2n}}{(2n)!} \prod_{i=1}^{2n} \int \frac{d\xi_i}{2\pi} e^{-iM_o(\xi_{2n} + \xi_{2n-1} + \dots + \xi_1)} e^{2iM(\xi_{2n-1} + \xi_{2n-3} + \dots + \xi_1)} \hat{T}_{2n} \right\} | \{ \vec{\sigma}_k^{in} \} \rangle, \quad (\text{A11})$$

where \hat{T}_{2n} is

$$\hat{T}_{2n} = \left[e^{i\xi_{2n} \sum_{k=1}^N \hat{\sigma}_k^z} \hat{U}^\dagger e^{i\xi_{2n-1} \sum_{k=1}^N \hat{\sigma}_k^z} \hat{U} \dots \hat{U}^\dagger e^{i\xi_1 \sum_{k=1}^N \hat{\sigma}_k^z} \hat{U} \right]. \quad (\text{A12})$$

From (A11) we can now write the full correlation function $P_{M_o, M}^{11}(t)$ as

$$\begin{aligned}
P_{M_o, M}(t) &\equiv \langle R_{M_o, M}^*(t) R_{M_o, M}(t) \rangle \\
&= \sum_{n=0}^{\infty} \sum_{m=0}^{\infty} \frac{(i\Delta_o(\Phi)t)^{2(n+m)}}{(2n)!(2m)!} \prod_{i=1}^{2n} \prod_{j=1}^{2m} \int \frac{d\xi_i}{2\pi} \int \frac{d\xi'_j}{2\pi} e^{-iM_o(\sum_i^{2n} \xi_i - \sum_j^{2m} \xi'_j)} e^{2iM(\sum_{i=odd}^{2n-1} \xi_i - \sum_{j=odd}^{2m-1} \xi'_j)} \langle \hat{T}_{2m}^\dagger \hat{T}_{2n} \rangle. \quad (A13)
\end{aligned}$$

We now use the assumption that the β_k are small; more precisely we assume that the orthogonality exponent κ , defined previously by $e^{-\kappa} = \prod \cos \beta_k$ (cf. eqtn (3.23)), can be approximated by the perturbative expansion $\kappa \approx \frac{1}{2} \sum \beta_k^2$. This assumption makes it much easier to calculate the average in (A13). We consider first the problem with only one environmental spin $\vec{\sigma}_k$, and calculate the average $\langle \hat{T}_{2m}^\dagger \hat{T}_{2n} \rangle_k$ in this case; since $\hat{T}_{2m}^\dagger \hat{T}_{2n}$ is a product of operators acting separately on each $\vec{\sigma}_k$, the average over all spins is also the product of single spin results.

We only need consider processes with 0, 1, or 2 flips of the environmental spin, i.e., we expand in powers of β_k , and stop at β_k^2 . Then it is clear that, if the initial state of $\vec{\sigma}_k$ is $|\uparrow_k\rangle$

$$\begin{aligned}
\hat{T}_{2n}^{(k)} |\uparrow_k\rangle &= e^{i\xi_{2n}\hat{\sigma}_k^z} e^{-i\beta_k\hat{\sigma}_k^x} \dots e^{-i\beta_k\hat{\sigma}_k^x} e^{i\xi_1\hat{\sigma}_k^z} e^{i\beta_k\hat{\sigma}_k^x} |\uparrow_k\rangle \\
&= e^{i\sum_{i=1}^{2n} \xi_i} \left[(1 - n\beta_k^2) |\uparrow_k\rangle + i\beta_k |\downarrow_k\rangle \sum_{l=1}^{2n} (-1)^{l+1} e^{-2i\sum_{i=1}^{2n} \xi_i} \right. \\
&\quad \left. - \beta_k^2 |\uparrow_k\rangle \sum_{l'=l+1}^{2n} \sum_{l=1}^{2n-1} (-1)^{l'-l} e^{-2i\sum_{i=l}^{l'-1} \xi_i} + O(\beta_k^3) \right], \quad (A14)
\end{aligned}$$

where the first term arises from the sequence $[11 \uparrow \dots 11]$, the second from the sequence $[11 \uparrow \dots \uparrow \downarrow \downarrow \dots \downarrow \downarrow]$, with a flip when $j = l$; and so on. In the same way we find

$$\begin{aligned}
\langle \uparrow_k | (\hat{T}_{2m}^{(k)})^\dagger \hat{T}_{2n}^{(k)} | \uparrow_k \rangle &= e^{i(\sum_{i=1}^{2n} \xi_i - \sum_{j=1}^{2m} \xi'_j)} \left[1 - \beta_k^2 [(n+m) + \sum_{l'=l+1}^{2n} \sum_{l=1}^{2n-1} (-1)^{l'-l} e^{-2i\sum_{i=l}^{l'-1} \xi_i} \right. \\
&\quad + \sum_{p'=p+1}^{2m} \sum_{p=1}^{2m-1} (-1)^{p'-p} e^{2i\sum_{j=p}^{p'-1} \xi'_j} \\
&\quad \left. - \sum_{p=1}^{2m} \sum_{l=1}^{2n} (-1)^{l+p} e^{-2i(\sum_{i=l}^{2n} \xi_i - \sum_{j=1}^{p-1} \xi'_j)} \right], \quad (A15)
\end{aligned}$$

to order β_k^2 . The sequence $\langle \downarrow_k | (\hat{T}_{2m}^{(k)})^\dagger \hat{T}_{2n}^{(k)} | \downarrow_k \rangle$ will have a similar expression, but with reversed signs coming from the $e^{i\xi_j \hat{\sigma}_k^z}$ factors.

We now observe that the state with polarisation M_o consists of $(N + M_o)/2$ spins up and $(N - M_o)/2$ spins down. Consequently, for each $\vec{\sigma}_k$, we add \uparrow or \downarrow averages like (A15), and then take the product

$$\langle \hat{T}_{2m}^\dagger \hat{T}_{2n} \rangle = \prod_{k=1}^{N_\uparrow} \langle (\hat{T}_{2m}^{(k)})^\dagger \hat{T}_{2n}^{(k)} \rangle \prod_{k'=1}^{N_\downarrow} \langle (\hat{T}_{2m}^{(k')})^\dagger \hat{T}_{2n}^{(k')} \rangle \quad (A16)$$

Substituting (A15) into this expression we get

$$\langle \hat{T}_{2m}^\dagger \hat{T}_{2n} \rangle = e^{iM_o(\sum_i^{2n} \xi_i - \sum_j^{2m} \xi'_j)} \exp \{ -K_{nm}^{eff}(\xi_i, \xi'_j, M_o) \}, \quad (A17)$$

where the "effective action" $K_{nm}^{eff}(\xi_i, \xi_j, M_o)$ has two contributions $K^{eff} = K_1 + K_2$:

$$\begin{aligned}
K_1 &= 2\kappa \left(1 - \frac{M_o}{N}\right) \left\{ (n+m) + \sum_{l>l} (-1)^{l'-l} \cos \left[2 \sum_{i=l}^{l'-1} \xi_i \right] + \sum_{p'>p} (-1)^{p'-p} \cos \left[2 \sum_{j=p}^{p'-1} \xi'_j \right] \right. \\
&\quad \left. - \sum_{p=1}^{2m} \sum_{l=1}^{2n} (-1)^{l+p} \cos \left[2 \sum_{i=l}^{2n} \xi_i - \sum_{j=1}^{p-1} \xi'_j \right] \right\}, \quad (A18)
\end{aligned}$$

$$K_2 = 2\kappa \frac{M_o}{N} \left\{ \sum_{l' > l} (-1)^{l'-l} \exp[-2i \sum_{i=l}^{l'-1} \xi_i] + \sum_{p' > p} (-1)^{p'-p} \exp[2i \sum_{j=p}^{p'-1} \xi'_j] \right. \\ \left. - \sum_{p=1}^{2m} \sum_{l=1}^{2n} (-1)^{l+p} \exp[2i \sum_{j=1}^{p-1} \xi'_j - 2i \sum_{i=l}^{2n} \xi_i] \right\}, \quad (\text{A19})$$

We recall now that $M_o \leq N^{1/2} \ll N$, which allows us to neglect the contribution due to K_2 and drop the correction $\sim M_o/N$ to the coefficient κ in K_1 . Notice also that the phase factor in front of $\exp\{-K^{eff}\}$ in (A16) cancels exactly the phase proportional to M_o in the formula (A13) for $P_{M_o, M}(t)$. Thus, quite surprisingly, we find the correlation function to be independent of M_o in this limit:

$$P_M(t) = \sum_{n=0}^{\infty} \sum_{m=0}^{\infty} \frac{(i\Delta_o(\Phi)t)^{2(n+m)}}{(2n)!(2m)!} \prod_{i=1}^{2n} \prod_{j=1}^{2m} \int \frac{d\xi_i}{2\pi} \int \frac{d\xi'_j}{2\pi} \exp\{2iM(\xi_{2n-1} + \xi_{2n-3} + \dots + \xi_1) - K_{nm}^{eff}(\xi_i, \xi'_j)\}, \quad (\text{A20})$$

We can render this expression more useful by changing variables; first we consider the whole sequence $\xi_\alpha = (\xi_1, \dots, \xi_{2n}, -\xi'_1, \dots, -\xi'_{2m})$ together, and then define new angular variables

$$\chi_\alpha = \sum_{\alpha'=\alpha}^{2(n+m)} 2\xi_{\alpha'} + \pi\alpha, \quad (\text{A21})$$

so that now

$$P_M(t) = \sum_{n=0}^{\infty} \sum_{m=0}^{\infty} \frac{(i\Delta_o(\Phi)t)^{2(n+m)}}{(2n)!(2m)!} \left(\prod_{\alpha=1}^{2(n+m)} \int \frac{d\chi_\alpha}{2\pi} \right) \\ \times \exp\left\{ iM \sum_{\alpha} (-1)^{\alpha+1} \chi_\alpha - 2\kappa \left[(n+m) + \sum_{\alpha' > \alpha} \cos(\chi_\alpha - \chi_{\alpha'}) \right] \right\}. \quad (\text{A22})$$

Thus we have mapped our problem onto the partition function of a rather peculiar system of spins, interacting via infinite range forces, with interaction strength 2κ .

To deal with this partition function, we define "pseudo-spins" $\vec{s}_\alpha = (\cos \chi_\alpha, \sin \chi_\alpha)$ and \vec{S} , such that

$$\vec{S} = \sum_{\alpha=1}^{2(n+m)} \vec{s}_\alpha, \quad \sum_{\alpha', \alpha} \cos(\chi_\alpha - \chi_{\alpha'}) = \vec{S}^2, \quad (\text{A23})$$

We can think of \vec{s}_α as rotating in our fictitious angular space defined by the projection operator (A10). Now consider the term $G(\vec{S})$ in (A22) defined by

$$G(\vec{S}) = \left(\prod_{\alpha=1}^{2(n+m)} \int \frac{d\chi_\alpha}{2\pi} e^{iM(-1)^{\alpha+1}\chi_\alpha} \right) \exp\left\{ -\kappa \sum_{\alpha', \alpha} \cos(\chi_\alpha - \chi_{\alpha'}) \right\} \\ = \left(\prod_{\alpha=1}^{2(n+m)} \int \frac{d\chi_\alpha}{2\pi} e^{iM(-1)^{\alpha+1}\chi_\alpha} \right) e^{-\kappa \vec{S}^2}. \quad (\text{A24})$$

This is easily calculated, viz.,

$$G(\vec{S}) = \int d\vec{S} e^{-\kappa \vec{S}^2} \prod_{\alpha=1}^{2(n+m)} \int \frac{d\chi_\alpha}{2\pi} e^{iM(-1)^{\alpha+1}\chi_\alpha} \delta\left(\vec{S} - \sum_{\alpha} \vec{s}_\alpha\right) \\ = \int \frac{d\vec{z}}{2\pi} \int d\vec{S} e^{-\kappa \vec{S}^2 + i\vec{z} \cdot \vec{S}} \left(\int_0^{2\pi} \frac{d\chi_\alpha}{2\pi} e^{-i\vec{z} \cdot \vec{s}_\alpha + iM\chi_\alpha} \right)^{2(n+m)} \\ = \frac{1}{2\kappa} \int dz z e^{-z^2/4\kappa} J_M^{2(n+m)}(z), \quad (\text{A25})$$

where $J_M(\lambda)$ is the M th-order Bessel function. Using

$$\sum_{l=0}^{\infty} \frac{\delta_{2(n+m),2s}}{(2m)!(2n)!} = \frac{\delta_{s,0} + 2^{2s}}{2(2s)!}, \quad (\text{A26})$$

to reorganize the sum over n and m in (A22) and changing the integration variable $z \rightarrow 2x\sqrt{\kappa}$, we then find

$$\begin{aligned} P_M(t) &= 2 \int_0^{\infty} dx x e^{-x^2} \frac{1}{2} \left(1 + \sum_{s=0}^{\infty} \frac{[2it\Delta_o(\Phi)J_M(2x\sqrt{\kappa})]^{2s}}{(2s)!} \right) \\ &= P_M(t) = \int_0^{\infty} dx x e^{-x^2} (1 + \cos[2\Delta_o(\Phi)J_M(2x\sqrt{\kappa})t]) \equiv 2 \int_0^{\infty} dx x e^{-x^2} P_{11}^{(0)}(t, \Delta_M(x)). \end{aligned} \quad (\text{A27})$$

$$\Delta_M(x) = \Delta_o(\Phi)J_M(2x\sqrt{\kappa}). \quad (\text{A28})$$

Here we come to the crucial point in our derivation. Eq.(A27) gives the final answer as a *superposition of non-interacting* correlation functions for effective tunneling rates $\Delta_M(x)$ with the proper weighting. For $M = 0$ this is the form quoted in Eq.(3.21) of the text.

It is worth noting that non-zero M enters this calculation as the overall phase factor which we can follow from (A13) up to (A25), where we finally integrate over $\{\chi_\alpha\}$ to produce the Bessel function of order M . This observation allows one to generalise any calculation done for $M = 0$ to finite M by simply replacing $J_0 \rightarrow J_M$ in the final answer - the prescription which we use in other Appendices.

APPENDIX B: DERIVATIONS FOR THE GENERIC CASE

We outline here the derivations for section 4, in which topological decoherence, degeneracy blocking, and orthogonality blocking are all simultaneously incorporated (the average over bias fluctuations being essentially trivial- see Appendix A.1). We have demonstrated in section 3 and Appendix A how each different term in the effective Hamiltonian (2.16) influence the central spin dynamics. From these limiting cases we learned that static (or diagonal) terms in the Hamiltonian can be partly absorbed into a redefinition of the transition amplitude between states with equal initial and final energies. If we now deal with the full central spin Hamiltonian, we can still write the instanton expansion in central spin transitions in the form (see (A4)):

$$P_M(t) = \int_{-i\infty}^{i\infty} dp_1 dp_2 \frac{e^{(p_1+p_2)t}}{(p_1 - i\epsilon)(p_2 - i\epsilon)} \sum_{n=0}^{\infty} \sum_{m=0}^{\infty} \left(\frac{(-i\Delta_o)^2}{p_1^2 + \epsilon^2} \right)^n \left(\frac{(-i\Delta_o)^2}{p_2^2 + \epsilon^2} \right)^m B_{nm}(M), \quad (\text{B1})$$

$$B_{nm}(M) = \sum_{\{g_l = \pm\}} e^{i\Phi \sum_{l=1}^{2(n+m)} g_l} \langle \hat{T}_{2m}^\dagger(M, g_l) \hat{T}_{2n}(M, g_l) \rangle, \quad (\text{B2})$$

where the sum over $\{g_l = \pm\}$ with $1 \leq l \leq 2(n+m)$ describes all possible clockwise and anticlockwise transitions, and the operator product is defined as

$$\hat{T}_{2n}(M, g_l) = \hat{U}_M(g_1) \hat{U}_M^\dagger(g_2) \hat{U}_M(g_3) \dots \hat{U}_M^\dagger(g_{2n}), \quad (\text{B3})$$

$$\hat{U}_M(g) = \hat{\Pi}_M e^{ig \sum_k \alpha_k \vec{n}_k \cdot \hat{\sigma}_k} e^{-i\beta_k \hat{\sigma}_k^x} \hat{\Pi}_{-M}. \quad (\text{B4})$$

Here $\hat{\Pi}_M$ as before projects on the polarisation state $\Delta N = M$, and β_k describes the mismatch between the initial and final nuclear spin states. If all the couplings were equal ($\omega_k = \omega_o \gg \Delta_o$) then the above set of equations would be the complete solution of the M polarisation group dynamics. One may then further average over different grains in the ensemble by summing over different polarisation groups with proper weighting. If there is a small spread in the nuclear hyperfine couplings, it will produce an internal bias field acting on the grain, as described in the text (section IV.C). The final answer for the ensemble of grains is obtained then by averaging (B1) over the bias field. This bias field is due to *all* environmental spins interacting with \vec{S} , and hardly changes when a few nuclei (of order $\sim \lambda$) flip

with \vec{S} . For this reason there is no back influence of the induced nuclear spin flips on the bias field, at least during the time scale set by the damping of coherent oscillations (when many environmental spins are flipped the coherence is obviously already lost).

The crucial observation is that if the sum over the clockwise and anticlockwise trajectories and the average of the operator product in (B2) can be presented as some weighted average and/or sum, of form

$$B_{nm}(M) = \int dx_1 dx_2 \dots dx_a \sum_{k_1 k_2 \dots k_b} Z_M(x_1, \dots, x_a; k_1, \dots, k_b) R_M^{2(n+m)}(x_1, \dots, x_a; k_1, \dots, k_b), \quad (\text{B5})$$

with fixed integer values a and b , then the problem may be considered as solved because the instanton summation then reduces to that of a coherent (non-interacting) dynamics with the renormalized tunneling amplitude

$$\Delta_o \longrightarrow \Delta_M(x_1, \dots, x_a; k_1, \dots, k_b) = \Delta_o R_M(x_1, \dots, x_a; k_1, \dots, k_b). \quad (\text{B6})$$

and the final answer acquires a form

$$P_M(t, \epsilon) = \int dx_1 dx_2 \dots dx_a \sum_{k_1 k_2 \dots k_b} Z_M(x_1, \dots, x_a; k_1, \dots, k_b) P_{11}^{TLLS}(t, \epsilon, \Delta_M(x_1, \dots, x_a; k_1, \dots, k_b)), \quad (\text{B7})$$

where $P_{11}^{TLLS}(t, \epsilon, \Delta_M)$ is described by Eq. (A4).

We have already seen that Eq. (B5) is indeed valid for the cases of pure topological decoherence and pure orthogonality blocking- we now prove that it also holds when we combine the effects of topological decoherence with the projection on a given polarisation state. Here we evaluate the $M = 0$ contribution; the result for $P_M(t)$ then follows from the generalisation explained at the end of the previous Appendix.

Introducing as before the spectral representation for the projection operator [see Eq. (A10)] we write

$$B_{nm}(M) = \sum_{\{g_l = \pm\}} e^{i\Phi \sum_{l=1}^{2(n+m)} g_l} \prod_{\rho=1}^{2(n+m)} \int \frac{d\xi_\rho}{2\pi} \exp \left\{ -K_{nm}^{eff}(\{g_l\}, \{\xi_\rho\}) \right\}. \quad (\text{B8})$$

$$\exp \left\{ -K_{nm}^{eff}(\{g_l\}, \{\xi_\rho\}) \right\} = \langle e^{i\xi_1 \hat{P}} e^{ig_1 \sum_k \alpha_k \vec{n}_k \cdot \hat{\sigma}_k} e^{i\xi_2 \hat{P}} e^{ig_2 \sum_k \alpha_k \vec{n}_k \cdot \hat{\sigma}_k} \dots e^{i\xi_{2(n+m)} \hat{P}} e^{ig_{2(n+m)} \sum_k \alpha_k \vec{n}_k \cdot \hat{\sigma}_k} \rangle. \quad (\text{B9})$$

With the usual assumption that the individual α_k are small (but not necessarily λ), the "effective action" K_{nm}^{eff} can be written as (compare Eq.(A22))

$$K_{nm}^{eff}(\{\xi_\rho\}) = \lambda' \sum_{\rho', \rho}^{2(n+m)} g_\rho g_{\rho'} + \lambda \sum_{\rho', \rho}^{2(n+m)} \cos(\chi_\rho - \chi_{\rho'}) g_\rho g_{\rho'}, \quad (\text{B10})$$

which generalizes from orthogonality blocking; the χ_ρ are defined as in (A21), and

$$\lambda = \frac{1}{2} \sum_{k=1}^N \alpha_k^2 (1 - (n_k^z)^2); \quad \lambda' = \frac{1}{2} \sum_{k=1}^N \alpha_k^2 (n_k^z)^2. \quad (\text{B11})$$

as before. We use the same trick of introducing "pseudo-vectors" $\vec{s}_\rho = (\cos \chi_\rho, \sin \chi_\rho)$, and $\vec{S}^2 = \left(\sum_{\rho=1}^{2(n+m)} g_\rho \vec{s}_\rho \right)^2 = \sum_{\rho', \rho} g_\rho g_{\rho'} \cos(\chi_\rho - \chi_{\rho'})$, to decouple integrals over the new variables $\chi_\rho = \chi_\rho + \pi g_\rho / 2$. After some lengthy, but straightforward algebra we get $P_{11}(t)$ in the form

$$P_0(t) = 2 \int dx x e^{-x^2} \int \frac{d\varphi}{2\pi} \sum_{m=-\infty}^{\infty} F_{\lambda'}(m) e^{i2m(\Phi - \varphi)} P_{11}^{(0)}(t, \Delta_o(\varphi, x)) \quad (\text{B12})$$

where $\Delta_o(\varphi, x) = 2\Delta_o \cos \varphi J_0(2x\sqrt{\lambda})$ as before.

The case of complex α_k (even assuming $\omega_k^\perp = 0$ in the effective Hamiltonian) is more subtle technically, but goes through in exactly the same way. Here we just outline the key steps; a more detailed derivation may be found in⁷. The effective action now has the form

$$K_{nm}^{eff} = \sum_{\rho, \rho'=1}^{2(n+m)} g_{\rho} g_{\rho'} \left\{ [\lambda' - \eta'(-1)^{\rho+\rho'} - i\gamma'((-1)^{\rho} + (-1)^{\rho'})] \right. \\ \left. + \cos(\chi_{\rho} - \chi_{\rho'}) [(\lambda - \lambda') - (-1)^{\rho+\rho'}(\eta - \eta') - i(\gamma - \gamma')((-1)^{\rho} + (-1)^{\rho'})] \right\}, \quad (\text{B13})$$

where the constants are defined by:

$$\lambda = \frac{1}{2} \sum_{k=1}^N \alpha_k^2; \quad \lambda' = \frac{1}{2} \sum_{k=1}^N \alpha_k^2 (n_k^z)^2; \quad (\text{B14})$$

$$\eta = \frac{1}{2} \sum_{k=1}^N \xi_k^2; \quad \eta' = \frac{1}{2} \sum_{k=1}^N \xi_k^2 (v_k^z)^2; \quad (\text{B15})$$

$$\gamma = \frac{1}{2} \sum_{k=1}^N \alpha_k \xi_k \vec{n}_k \cdot \vec{v}_k; \quad \gamma' = \frac{1}{2} \sum_{k=1}^N \alpha_k \xi_k n_k^z v_k^z; \quad (\text{B16})$$

As before we change variables according to $\chi_{\rho} = \chi_{\rho} + \pi$ when $g_{\rho} = -1$, to introduce odd and even spin fields

$$\vec{\mathcal{S}}_o = \sum_{\rho=odd}^{2(n+m)-1} \vec{s}(\chi_{\rho}); \quad \vec{\mathcal{S}}_e = \sum_{\rho=even}^{2(n+m)} \vec{s}(\chi_{\rho}). \quad (\text{B17})$$

which are used to decouple integrations over χ_{ρ} with the final goal to get the answer in the form of Eq. (B5). This indeed can be done, and the final answer reads

$$P_{11}(t) = \int \frac{d\varphi_1}{2\pi} \int \frac{d\varphi_2}{2\pi} \sum_{m_1=-\infty}^{\infty} \sum_{m_2=-\infty}^{\infty} \int dx_1 \int dx_2 \\ \times \mathcal{Z}(\varphi_1, \varphi_2, x_1, x_2, m_1, m_2) P_{11}^{(0)}[t, \tilde{\Delta}_o(x_1, x_2, \varphi_1, \varphi_2)], \quad (\text{B18})$$

and (B18) has an obvious generalisation to include the bias integration $\int d\epsilon$. The weight is given by

$$\mathcal{Z} = e^{2i[m_1(\Phi - \varphi_1) - m_2\varphi_2 + 4m_1 m_2 \gamma']} e^{4(\eta' m_2^2 - \lambda' m_1^2)} \\ \times \frac{x_1 x_2}{8(ab - c^2)} I_0 \left(\frac{(a+b)x_1 x_2}{8(ab - c^2)} \right) \exp \left\{ \frac{(a-b+2ic)x_1^2 + (a-b-2ic)x_2^2}{16(ab - c^2)} \right\}, \quad (\text{B19})$$

and the renormalized tunneling splitting equals

$$\tilde{\Delta}_o^2(x_1, x_2, \varphi_1, \varphi_2) = 4\tilde{\Delta}_o^2 \cos(\varphi_1 + \varphi_2) \cos(\varphi_1 - \varphi_2) J_0(x_1) J_0(x_2), \quad (\text{B20})$$

where

$$a = \lambda - \lambda'; \quad b = \eta - \eta'; \quad c = \gamma - \gamma'. \quad (\text{B21})$$

FIGURE CAPTIONS

Figure 1 The flow of a class of effective Hamiltonians describing a central system coupled to a background environment, in coupling constant space, as the UV cutoff in the joint Hilbert space is reduced from E_c to Ω_o . Here we show flow to a fixed point FP, in a simplified 2-dimensional space of couplings α_1, α_2 , but one may also have fixed lines or more complex topologies.

Figure 2 A typical path for a 2-level central system (solid line) coupled to environmental modes (wavy lines) as a function of time, showing the couplings which exist in both the spin-boson and central spin models. We show both diagonal couplings D to τ_z and non-diagonal couplings ND to τ_{\pm} (in the central spin model these are strong enough to lead to multiple excitation of environmental modes).

Figure 3 Definition of the longitudinal and transverse parts of the diagonal coupling to a bath spin in the Central Spin Hamiltonian, in terms of the initial and final fields $\vec{\gamma}^{(1)}$ and $\vec{\gamma}^{(2)}$ acting on this spin- this also defines the angle β , and the mutually perpendicular unit vectors \hat{l} and \hat{m} (see text).

Figure 4 Classifying the states of the Central spin Hamiltonian. Each level of $\vec{\tau}$ is associated with a 2^N -fold multiplet of bath states (Fig 6(a)). These are classified into polarisation groups $\{M\}$ (where M is the total polarisation along \hat{z}), separated by energy ω_o and with width $\tilde{\Gamma}_M$; Fig 6(b) shows the density of states $G_M(\xi)$ of the separate groups, and Fig. 6(c) their sum $W(\xi)$. We show $W(\xi)$ for 2 different values of the parameter $\mu = \tilde{\Gamma}_M/\omega_o$; in realistic cases $\mu \gg 1$ (ie., the polarisation groups strongly overlap), and $W(\xi)$ is Gaussian. Longitudinal transitions between 2 different polarisation groups M_1 and M_2 go at a rate T_1^{-1} ; transitions within a polarisation group at a rate T_2^{-1} .

Figure 5 Example of the application of the Central Spin model to a magnetic macromolecule (the *Fe-8* molecule, further described in section 5). In (a) we show the effective tunneling matrix element $|\tilde{\Delta}_{eff}| = |\Delta \cos(\pi S + i\beta_o \mathbf{n}_o \cdot \mathbf{H}_o)|$, for this easy axis/easy plane nanomagnet in the presence of a field $\mathbf{H}_o = \hat{x}H_x$ in the x -direction (transverse to the easy axis), assuming an angle φ between \hat{x} and the magnetic "hard axis" (perpendicular to the easy plane). Aharonov-Bohm oscillations appear when φ is small, so that the action of the 2 relevant paths on the spin sphere have similar *magnitudes*, but almost opposite phase. For larger φ , one path dominates over the other and oscillations are suppressed. In (b) we show a histogram of the ω_k^{\parallel} for this system- the main figure shows the protons and the lower inset the N and O contributions. The upper inset in (b) shows the variation of E_o and ξ_o with H_x (the parameter ξ_o is discussed in sections 4 and 5). These figures are adapted from Ref. [69].

Figure 6 Behaviour of $P_{11}(t)$ in the case of pure topological decoherence. We show $P_{11}(t) - 1/2$ for intermediate coupling, for which $P_{11}(t)$ takes the "universal form" discussed in the text.

Figure 7 The effect of relaxation on a statistical ensemble of central spins, each interacting with a spin bath. In (a) we assume that $\lambda = 0$, $\kappa = 5$ and $N = 1000$, and show the normalised time dependence of 3 different contributions $P_M(t)$ to the total relaxation function $P_{11}(t)$; they sum to give a roughly logarithmic time dependence for the total function $P_{11}(t)$. The small M contributions relax quickly (up to $M \sim \kappa$), so the effect on an initial ensemble distributed over bias ξ , at short times, is to dig a hole around zero bias, of width $\sim \kappa\omega_o$. In (b) we show the spectral absorption function $\chi''(\omega)$ for $\kappa = 2$, dividing this into the $M = 0$ contribution and the contributions from higher M groups (which relax more slowly and thus peak at lower ω).

Figure 8 The spectral absorption function $\chi''_{M=0}(\omega)$ for several values of κ , for an ensemble of central spins in the $M = 0$ polarisation group, in the case where orthogonality blocking dominates, and degeneracy blocking effects (ie., a bias average) are also incorporated. Contributions from higher polarisation groups $M \neq 0$ are not shown; they are spread over a range $\sim M\omega_o$, up to $\sim \kappa\omega_o$. Contributions from groups with $M > \kappa$ are negligible.

Figure 9 Graphs of $\chi''_{M=0}(\omega)$ for "projected topological decoherence" (ie., including a bias average over an ensemble in which topological decoherence dominates), for several different values of the parameter $(\lambda - \lambda')$. Contributions from higher polarisation groups, which are spread over an energy range $\sim \lambda\omega_o$, are not shown.

¹ Classical oscillator models of environments go back to Rayleigh (at least). Quantum models of bosonic environments began with the development of quantum electrodynamics (see, eg., P.A.M.Dirac, Proc. Roy. Soc. **A114**, 243 (1927), or E. Fermi, Rev. Mod. Phys. **4**, 87 (1932)), and later became an integral part of quantum optics and condensed matter physics (in the form of "quasiparticles"). The theory of quantum "Brownian motion" (for which see, eg., I.R. Senitzky, Phys. Rev. **119**, 670 (1960); J. Schwinger, J. Math. Phys. **2**, 407 (1961), G.W. Ford, M. Kac, P. Mazur, J. Math. Phys. **6**, 504 (1965), and A.O.Caldeira, A.J. Leggett, Physica **121A**, 587 (1983)) has also exercised an important influence on such models.

The development of oscillator models for fermionic baths belongs mostly to the history of condensed matter physics, beginning with F. Bloch, Zeit. fur Physik **81**, 363 (1933), for spin excitations, or L.D. Landau, JETP **16**, 574 (1946), D. Bohm and E.P. Gross, Phys. Rev. **75**, 1851 (1949), and S. Tomonaga, Prog. Theor. Phys. **5**, 349 (1950), for electronic charge excitations.

The first attempt to put oscillator models on a general footing was by Feynman and Vernon¹³, who recognised their perturbative nature; more recently their development in many fields in physics has followed the ideas of Leggett et al.^{10,12}, particularly in the application to tunneling phenomena in complex systems^{22,23}, and to quantum dissipation theory¹¹.

² "Random level" models of quantum environments begin with the work of E.P. Wigner, Ann. Math **53**, 36 (1953) (see also D.L Hill, J.A. Wheeler, Phys. Rev. **89**, 1102 (1953)) and F.J. Dyson, J. Math. Phys. **4**, 140, 157, 166 (1962). In recent years they have been formulated field-theoretically (see, eg., K.B. Efetov, Adv. Phys. **32**, 53 (1983)), and applied in condensed matter physics (particularly mesoscopic physics- see K.B Efetov, "Supersymmetry in Disorder and Chaos", C.U.P. (1997), C.W.J. Beenaker, Rev. Mod. Phys. **69**, 731 (1997), or B.L. Altshuler, B.D.Simons, in "Mesoscopic Quantum Physics", Les

- Houches session LXI (ed. E.Akkermans et al., (1994)), pp. 1-98); and in nuclear physics. For general studies of environmental dissipation with such models, see M. Wilkinson, J. Phys. **A21**, 4021 (1988), M. Wilkinson, E.J. Austin, Phys. Rev **A46**, 64 (1992), and J. Phys. **A28**, 2277 (1995); and A. Bulgac, G. Do Dang, D. Kusnezov, Ann. Phys. **242**, 191 (1995), and Phys. Rev **E54**, 3468 (1996).
- ³ "Spin bath" Models in which the environment is explicitly modelled as a set of "spins", or 2-level systems, probably began in NMR and quantum optics (see eg., Y.R.Shen, Phys. Rev **155**, 921 (1967), or A.S. Davydov, A.A. Serikov, Phys. Stat Sol. (b) **51**, 57 (1972)), but these studies were not only in the weak coupling limit but also used phenomenological damping equations, in which all "memory" and "back-reaction" effects (including phase exchange with the environment) are lost. More recent studies have appeared in the context of $1/f$ noise⁹⁴, SQUID tunneling^{17,19}, in Landau-Zener dynamics^{32,69,74}, and in magnetic systems^{5-9,20,31,35,70}, as well as in a more general context¹⁹. Attempts to map spin bath models to an oscillator bath description (which are only generally valid in the weak-coupling limit) include refs.^{17-19,77}. Some papers^{15,16} achieve a weak-coupling limit by multiplying all couplings by $1/N$, where N is the number of bath spins- we do not believe this procedure is physically correct. The solution to the 'Central Spin' model (the analogue for spin baths of the spin-boson model), including all relevant couplings and going beyond the weak coupling limit, was first given in refs.^{7,9}, with earlier partial solutions in ref.^{5,8,74}.
- ⁴ K.G. Wilson, Rev. Mod. Phys. **47**, 773 (1975).
- ⁵ N.V. Prokof'ev and P.C.E. Stamp, J. Phys. CM Lett. **5**, L663-L670 (1993)
- ⁶ P.C.E. Stamp, Physica **B197**,133 (1994)
- ⁷ For the original derivation of the dynamics of the central spin model, see N.V. Prokof'ev, P.C.E. Stamp, /cond-mat 9511011 (UBC preprint, April 20, 1995), and ref.⁹. These papers contain analytic results for most parameter regimes of the model (some of which are quoted in section 4 of the present article).
- ⁸ N.V. Prokof'ev and P.C.E. Stamp, "Spin Environments and the Suppression of Quantum Coherence", pp. 347-371 in ref.²⁵.
- ⁹ N.V. Prokof'ev, P.C.E. Stamp, J. Low Temp. Phys., **104**, 143 (1996).
- ¹⁰ A.J. Leggett *et al.*, Rev. Mod. Phys. **59**, 1 (1987).
- ¹¹ U. Weiss, "Quantum Dissipative Systems" (World Scientific); 1st edition, 1993; 2nd edition, 1999.
- ¹² A.O. Caldeira and A.J. Leggett, Ann. Phys. (N.Y.), **149**, 374 (1983).
- ¹³ R.P. Feynman, F.L. Vernon, Ann. Phys. **24**, 118 (1963).
- ¹⁴ O.V. Lounasmaa, "Experimental Principles and Methods below 1 K" (Academic Press, 1974).
- ¹⁵ N.D. Mermin, Physica **177A**, 561 (1991)
- ¹⁶ J. Shao, P. Hanggi, Phys. Rev. Lett. **81**, 5710 (1998)
- ¹⁷ P.C.E. Stamp, Phys. Rev. Lett., **61**, 2905 (1988).
- ¹⁸ A.O. Caldeira, A.H. Castro-Neto, T. Oliveira de Carvalho, Phys. Rev. **B48**, 13974 (1993)
- ¹⁹ P.C.E. Stamp, pp. 101-197 in Tomsovic²³.
- ²⁰ M. Dubé, P.C.E. Stamp, J. Low Temp. Phys. **110**, 779 (1998); see also J. Low Temp. Phys. **113**, 1079 (1998).
- ²¹ Y. Imry, "Introduction to Mesoscopic Physics" (O.U.P., 1997)
- ²² "Quantum Tunneling in Condensed Matter", ed. Yu. Kagan, A.J. Leggett (Elsevier, 1992).
- ²³ "Tunneling in Complex Systems", ed. S. Tomsovic (World Scientific, 1998).
- ²⁴ P.C.E. Stamp, E.M. Chudnovsky, and B. Barbara, Int. J. Mod. Phys. **B6**, 1355-1478 (1992).
- ²⁵ "Quantum Tunneling of Magnetisation-QTM'94", Proc. NATO workshop, Chichilienne, June 1994 (ed. L. Gunther, B. Barbara); Kluwer publishing, 1995.
- ²⁶ Recent theoretical work on how to make qubits in superconductors includes Y. Makhlin et al., Nature **398**, 305 (1999), L.B. Ioffe et al., Nature **398**, 679 (1999), and J.E. Mooij et al., Science **285**, 1036 (1999). A recent experiment finds coherence of a single Cooper pair in mesoscopic superconductors; see Y. Nakamura, Yu. A. Pashkin, J.S. Tsai, Nature **398**, 786 (1999)
- ²⁷ Recent ideas on how to make qubits for quantum computers using nuclear spins in quantum Hall systems have attracted considerable interest- see V. Privman, I.D.Vagner, G. Kventsel, Phys Lett. **A236**, 141 (1998), and B. Kane, Nature **393**, 133 (1998).
- ²⁸ For work on quantum measurement theory from $\sim 1930 - 1980$, see M. Jammer, "The Philosophy of Quantum Mechanics" (Wiley, 1974), and "Quantum Theory and Measurement", ed. J.A. Wheeler, W.H Zurek (Princeton, 1983); see also J.S. Bell "Speakable and Unsayable in Quantum Mechanics", (C.U.P., 1987). The idea of using SQUIDS to test quantum theory, including measurement theory, on the macroscopic scale, comes from A.J. Leggett, Prog. Th. Phys (Japan) Supp. **69**, 80 (1980) [see also ref.⁹⁶].
- ²⁹ N.G. van Kampen, "Stochastic Processes in Physics and Chemistry" (Elsevier, 1992).
- ³⁰ L.F. Cugliandolo, G. Lozano, Phys. Rev. Lett. **80**, 4979 (1998).
- ³¹ A. Garg, Phys. Rev. Lett. **74**, 1458 (1995).
- ³² G. Rose, P.C.E. Stamp, J. Low Temp. Phys. **113**, 1153 (1998)
- ³³ F. Coppinger et al., Phys. Rev. Lett. **75**, 3513 (1995).
- ³⁴ C. Sangregorio et al., Phys. Rev. Lett. **78**, 4645 (1997)
- ³⁵ N.V. Prokof'ev, P.C.E. Stamp, Phys. Rev. Lett. **80**, 5794 (1998); N.V. Prokof'ev, P.C.E. Stamp, J. Low Temp. Phys. **113**, 1147 (1998).
- ³⁶ T. Ohm et al., Europhys. J. **B6**, 595 (1998); T. Ohm et al., J. Low Temp. Phys. **113**, 1141 (1998)

- ³⁷ L. Thomas et al., J. Low Temp. Phys. **113**, 1055 (1998); L. Thomas, A. Caneschi, B. Barbara, Phys. Rev. Lett. **83**, 2398 (1999).
- ³⁸ W. Wernsdorfer et al., Phys. Rev. Lett. **82**, 3903 (1999)
- ³⁹ W. Wernsdorfer, R. Sessoli, Science **284**, 133 (1999)
- ⁴⁰ W. Wernsdorfer, R. Sessoli, D. Gatteschi, Europhys. Lett. **47**, 254 (1999)
- ⁴¹ R.F. Voss, R.A. Webb, Phys. Rev. Lett. **47**, 265 (1981)
- ⁴² S. Washburn, R.A. Webb, R.F. Voss, S.M. Faris, Phys. Rev. Lett. **54**, 2712 (1985)
- ⁴³ A. N. Cleland, M. H. Devoret, J. Clarke, Phys. Rev. **B 36**, 58 (1987); and J. Clarke, A. N. Cleland, M.H. Devoret, D. Esteve, J. M. Martinis, Science **239**, 992 (1988)
- ⁴⁴ D. B. Schwartz, B. Sen, C. N. Archie, J. E. Lukens, Phys. Rev. Lett. **55**, 1547 (1985); R. Rouse, S. Han, J. E. Lukens, Phys. Rev. Lett. **75**, 1614 (1995); S. Han, R. Rouse, J. E. Lukens, Phys. Rev. Lett. **76**, 3404 (1996); and D.J. Flees, S. Han, J.E. Lukens, Phys. Rev. Lett. **78**, 4817 (1997).
- ⁴⁵ Y. Nakamura, C.D. Chen, J.S. Tsai, Phys. Rev. Lett. **79**, 2328 (1997).
- ⁴⁶ N.V. Prokof'ev and P.C.E. Stamp, to be published.
- ⁴⁷ U. Eckern, G. Schon, V. Ambegaokar, Phys. Rev. **B30**, 6419 (1984).
- ⁴⁸ L. Gammaitoni, P. Hanggi, P. Jung, F. Marchesoni, Rev. Mod. Phys. **70**, 223 (1996).
- ⁴⁹ M. Grifoni, P. Hanggi, Phys. Rep. **304**, 229 (1998).
- ⁵⁰ P. Hanggi, P. Talkner, M. Borkovec, Rev. Mod. Phys. **62**, 251 (1990)
- ⁵¹ For recent experiments on dipolar glasses, see D. Salvino et al., Phys. Rev. Lett. **73**, 268 (1994); S. Rogge, D. Natelson, D.D. Osheroff, Phys. Rev. Lett. **76**, 3136 (1996); D. Natelson, D. Rosenberg, D.D. Osheroff, Phys. Rev. Lett. **80**, 4689 (1998); C. Enss, S. Hunklinger, Phys. Rev. Lett. **79**, 2831 (1997); P. Strehlow, C. Enss, S. Hunklinger, Phys. Rev. Lett. **80**, 5361 (1998).
- ⁵² Experiments showing $1/f$ and telegraph noise in mesoscopic conductors include K. Rahls, R. Buhrman, Phys. Rev. Lett. **60**, 2434 (1988); N. Birge, B. Golding, W. Haemmerle, Phys. Rev. Lett. **62**, 195 (1989); and N. Zimmerman, B. Golding, W. Haemmerle, Phys. Rev. Lett. **67**, 1322 (1991).
- ⁵³ P. Mohanty, E.M. Jarivala, R.A. Webb, Phys. Rev. Lett. **78**, 3366 (1997); and Phys. Rev. **B55**, 13452 (1997).
- ⁵⁴ A.J. Leggett, Phys. Rev. **B30**, 1208 (1984)
- ⁵⁵ F.D.M. Haldane, Phys. Rev. Lett. **50**, 1153 (1983); Phys. Rev. Lett. **61**, 1029 (1998)
- ⁵⁶ M.V. Berry, Proc. Roy. Soc. **A392**, 45 (1984)
- ⁵⁷ The application of the spin phase to magnetic systems is reviewed in I.K. Affleck, J. Phys CM **1**, 3047 (1989); E. Manousakis, Rev. Mod. Phys. **63**, 1 (1991); E.S. Fradkin, *"Field Theories on Condensed Matter Physics"* (Addison-Wesley, 1991); and A. Auerbach, *"Interacting Electrons and Quantum Magnetism"* (Springer-Verlag, 1994). More general discussion is in A. Shapere, F. Wilczek, *"Geometric Phases in Physics"* (World Scientific, 1989).
- ⁵⁸ A. Stern, Y. Aharonov, Y. Imry, Phys. Rev **B40**, 3436 (1990)
- ⁵⁹ I.S. Tupitsyn, N.V. Prokof'ev, P.C.E. Stamp, Int. J. Mod. Phys. **B11**, 2901 (1997).
- ⁶⁰ For the mapping from non-linear couplings (to oscillator multiplets) to T -dependent linear couplings to a different oscillator bath, see Yu. M. Kagan, N.V. Prokof'ev, JETP **69**, 1250 (1989), A.H. Castro-Neto, A.O. Caldeira, Phys. Rev. **E48**, 4037 (1993), and M. Dubé, P.C.E. Stamp²⁰ for multiple phonons; P.C.E. Stamp^{24,72} for magnons; and N.V. Prokof'ev, Phys. Rev. **B49**, 2148 (1994) for Luttinger liquids.
- ⁶¹ H. Grabert, P. Schramm, G-L. Ingold, Phys. Rep. **168**, 115 (1998)
- ⁶² V. Hakim, V. Ambegaokar, Phys. Rev. **A32**, 423 (1985)
- ⁶³ A. Schmid, Phys. Rev. Lett. **51**, 1506 (1983).
- ⁶⁴ J.L. van Hemmen, A. Suto, Physica **B141**, 37 (1986).
- ⁶⁵ M. Enz, R. Schilling, J. Phys. **C19**, 1765 (1986); *ibid.*, L711 (1986).
- ⁶⁶ A. Abragam, B. Bleaney, *"Electron Paramagnetic Resonance of Transition Ions"* (Clarendon, 1970).
- ⁶⁷ E. du Tremolet de Laicheisserie, *"Magnetostriction: Theory and Applications of Megnetoelasticity"* (CRC Press, 1993).
- ⁶⁸ A.J. Leggett, in *"Frontiers and Borderlines in Many- Particle Physics"*, ed. R.A. Broglia, J.R. Schrieffer (North-Holland, 1988), pp. 276-329.
- ⁶⁹ G. Rose, P.C.E. Stamp, to be published; see also G. Rose, Ph.D. thesis (University of British Columbia, 1999).
- ⁷⁰ G. Rose, P.C.E. Stamp, I.S. Tupitsyn, preprint
- ⁷¹ A. P. Malozemoff and J. C. Slonczewski, *"Magnetic Domain Walls in Bubble Materials"* (Academic Press, 1979)
- ⁷² P.C.E. Stamp, Phys. Rev. Lett., **66**, 2802 (1991).
- ⁷³ G. Tataru and H. Fukuyama, Phys. Rev. Lett. **72**, 772 (1994), and J. Phys. Soc. Japan **63**, 2538 (1994).
- ⁷⁴ E. Shimshoni, Y. Gefen, Ann. Phys. **210**, 16 (1991).
- ⁷⁵ N. Abarenkova, J.C. Angles d'Auriac, Phys. Lett. **A219**, 335 (1996).
- ⁷⁶ E.N. Bogachek and I.V. Krive, Phys. Rev. B, **46**, 14559 (1992).
- ⁷⁷ A. Garg, Europhys. Lett. **22**, 205 (1993).
- ⁷⁸ N.V. Prokof'ev, P.C.E. Stamp, preprint.
- ⁷⁹ M. Dubé, P.C.E. Stamp, Int. J. Mod. Phys. **B11**, 1191 (1998)
- ⁸⁰ M. Dubé, P.C.E. Stamp, J. Low Temp. Phys. **113**, 1085 (1998); and to be published.

- ⁸¹ A.L. Burin, J. Low Temp. Phys. **100**, 309 (1995).
- ⁸² Yu, A. Bychkov, T. Maniv, I.D. Vagner, Sol. St. Comm. **94**, 61 (1995)
- ⁸³ M. Uehara, B. Barbara, J. Physique **47**, 235 (1986); M. Uehara, B. Barbara, B. Dieny, P. C. E. Stamp, Phys. Lett. **114A**, 23 (1986); B. Barbara, P. C. E. Stamp, M. Uehara, J de Physique **49**, C8-529 (1988); Ll. Balcells et al., Z. Phys. **B89**, 209 (1992); X. X. Zhang et al., Phys. Lett. **A163**, 130 (1992); X. X. Zhang et al., J. Phys. CM **4**, L163 (1992), and Phys. Rev. **B53**, 3336 (1996); W. Wernsdorfer et al., Phys. Rev. **B53**, 3341 (1996), and *ibid.* **B 55**, 11552 (1997).
- ⁸⁴ C. Paulsen et al., Phys. Lett. **161**, 319 (1991); C. Paulsen et al., Europhys. Lett. **17**, 643 (1992).
- ⁸⁵ K. Hong, N. Giordano, Phys. Rev. **B 51**, 9855 (1995); K. Hong, N. Giordano, J. Magn. Magn. Mat. **151**, 396 (1995); K. Hong and N. Giordano, J. Phys. CM **8**, L301 (1996); and K. Hong, N. Giordano, Europhys. Lett. **36**, 147 (1996).
- ⁸⁶ S. Mangin et al. Europhys. Lett. **39**, 675 (1997).
- ⁸⁷ W. Wernsdorfer et al., Phys. Rev. Lett. **77**, 1873 (1996)
- ⁸⁸ M. Novak and R. Sessoli, in ref.²⁵, pp 171-188 (1995); B. Barbara *et al.*, J. Magn. Magn. Mat., **140-144**, 1825 (1995); J. R. Friedman *et al.*, Phys. Rev. Lett., **76**, 3830-3833 (1996); L. Thomas *et al.*, Nature **383**, 145-147 (1996). J. M. Hernandez *et al.*, Europhys. Lett., **35**, 301-306 (1996).
- ⁸⁹ S.M.J. Aubin et al., J. Am. Chem. Soc. Chem. Comm. (1997), 2239; D. Ruiz et al. Angew. Chem. Int. Ed. **37**, 300 (1998).
- ⁹⁰ A. Cuccioli et al., Europhys. J. **B12**, 39 (1999).
- ⁹¹ W. Wernsdorfer et al., Univ. of Florence preprint (1999).
- ⁹² T.F. Rosenbaum, J. Phys. CM **8**, 9759 (1996), and refs. therein.
- ⁹³ "Electron-electron Interactions in Disordered Systems", ed. A.L. Efros, M. Pollak (North-Holland, 1985).
- ⁹⁴ B.L. Altshuler, B. Spivak, JETP Lett. **42**, 447 (1985); S. Feng, P.A. Lee, A. Stone, Phys. Rev. Lett. **56**, 1960 (1986); S. Feng, in "Mesoscopic Phenomena in Solids", ed. B.L. Altshuler et al., (Elsevier, 1991), pp. 107-128.
- ⁹⁵ D.S. Golubev, A.D. Zaikin, Phys. Rev. Lett. **81**, 1074 (1998); and /cond-mat 9804156; and for an opposing point of view, I.L. Aleiner, B.L. Altshuler, M.E. Gershenson, Phys. Rev. Lett. **82**, 3190 (1999)
- ⁹⁶ A.J. Leggett, in "Chance and Matter", Les Houches session XLVI, ed. J. Souletie, J. Vannimenus, R. Stora (North-Holland, 1987), pp. 395-506.
- ⁹⁷ C.D. Tesche, Phys. Rev. Lett. **64**, 2358 (1990).
- ⁹⁸ A.O. Caldeira, A.J. Leggett, Phys. Rev. **A31**, 1059 (1985).
- ⁹⁹ D.D. Awschalom et al., Science **258**, 414 (1992), S. Gider et al., Science **268**, 77 (1995)
- ¹⁰⁰ Some papers in the debate concerning the coherence experiments in ferritin⁹⁹ include refs.^{24,31}; A. Garg, Phys. Rev Lett. **70**, C2198 (1993), and reply of D. D. Awschalom et al., *ibid.*, C2199 (1993); A. Garg, Phys. Rev. Lett. **71**, 4241 (1993), and D. D. Awschalom et al., *ibid.*, C4276 (1993); or A. Garg, Science **272**, 425 (1996) and J. Tejada, Science **272**, 424 (1996), and reply by D. D. Awschalom et al, *ibid.*, 425 (1996)); N. V. Prokof'ev, P. C. E. Stamp^{5,8}; J. Tejada et al., Phys. Rev. Lett. **79**, 1754 (1997).
- ¹⁰¹ D.D Awschalom, M.A. McCord, G. Grinstein, Phys. Rev. Lett. **65**, 783 (1990).
- ¹⁰² See N.V. Prokof'ev, P.C.E Stamp (unpublished), and A.H. Castro-Neto, A. Zee (unpublished).
- ¹⁰³ The instanton calculus (which goes back to work by Langer in 1967) is nicely reviewed by S. Coleman "Aspects of Symmetry" (C.U.P., 1985), Ch. 7, and by L.S. Schulman, "Techniques and Applications of Path Integration" (Wiley, 1981), Ch. 29.
- ¹⁰⁴ For a general discussion of computation, including a reprint of Feynman's famous paper on quantum computation, see "Feynman's lectures on Computation", ed., A.J.G. Hey, R.W. Allen (Addison-Wesley, 1996).
- ¹⁰⁵ An introduction to Quantum Computation (without decoherence) is in "Introduction to Quantum Computers", by G.A. Berman, G.D. Doolen, R. Mainieri, V.I. Tsifrinovich (World Scientific, 1998).
- ¹⁰⁶ W.G. Unruh, Phys. Rev. **A51**, 992 (1995).
- ¹⁰⁷ S. Haroche, J.M. Raimond, Phys. Today **49**, No. 8 (Aug. 1996), pp. 51-52.
- ¹⁰⁸ P. Mohanty, cond-mat /9912263, to be published in Physica **B**, LT22 proceedings; and Ann. Phys. (Leipzig) **8**, 549 (1999).
- ¹⁰⁹ D.S. Golubev, A.D. Zaikin, Physica **B255**, 164 (1999); and cond-mat /9911316, to be published in Physica **B**, LT22 proceedings.
- ¹¹⁰ B.L. Altshuler et al., Physica **E3**, 58 (1998); I.L. Aleiner, B.L. Altshuler, M.E. Gershenson, Waves in Random Media **9**, 201 (1999).
- ¹¹¹ M. Vavilov, V. Ambegaokar, cond-mat/9902127
- ¹¹² Y. Imry, H. Fukuyama, P. Schwab, Europhys. Lett. **47**, 608 (1999)
- ¹¹³ A. Zawadowski, J. von Delft, D.C. Ralph, Phys. Rev. Lett. **83**, 2632 (1999)
- ¹¹⁴ W. Wernsdorfer, R. Sessoli, A. Caneschi, D. Gatteschi, A. Cornia, condmat/ (Europhys. Lett., in press).
- ¹¹⁵ E. del Barco et al., Europhys. Lett. **47**, 722 (1999).
- ¹¹⁶ B. Barbara et al., J. Mag. Magn. Mat. **200** (in press)
- ¹¹⁷ A. Caneschi et al., J. Mag. Magn. Mat. **200** (in press).
- ¹¹⁸ I. Tupitsyn, B.Barbara, chapter in "Magnetoscience-from Molecules to Materials", ed. Miller and Drillon (Wiley, 2000); /condmat 0002180.
- ¹¹⁹ J. Brooke, D. Bitko, T.F. Rosenbaum, G. Aeppli, Science **284**, 779 (1999)
- ¹²⁰ D.A.R. Dalvit et al., cond-mat/0001301 (2000)
- ¹²¹ D. Kilin, M. Schrieber, J. Lumin. **76&77**, 433 (1998)

- ¹²² H.D. Zeh, quant-ph/9905004 (1999)
- ¹²³ P. Hanggi et al., cond-mat/99102000 (1999)
- ¹²⁴ B. Elattari, S.A. Gurvitz, quant-ph/9908054 (1999)
- ¹²⁵ H.M. Wiseman et al., cond-mat/0002279 (2000)
- ¹²⁶ C.J. Myatt et al., Nature **403**, 269 (2000).

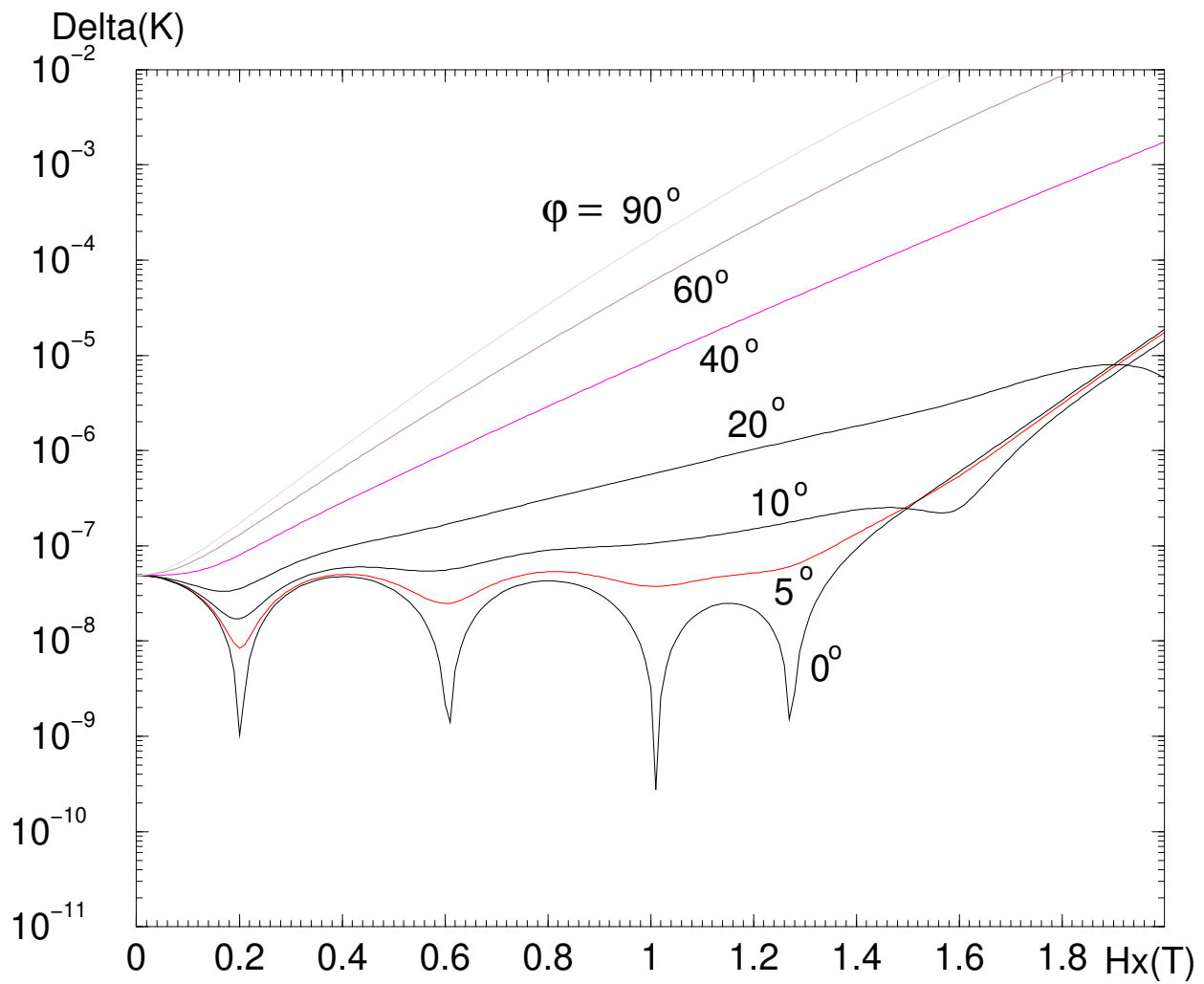

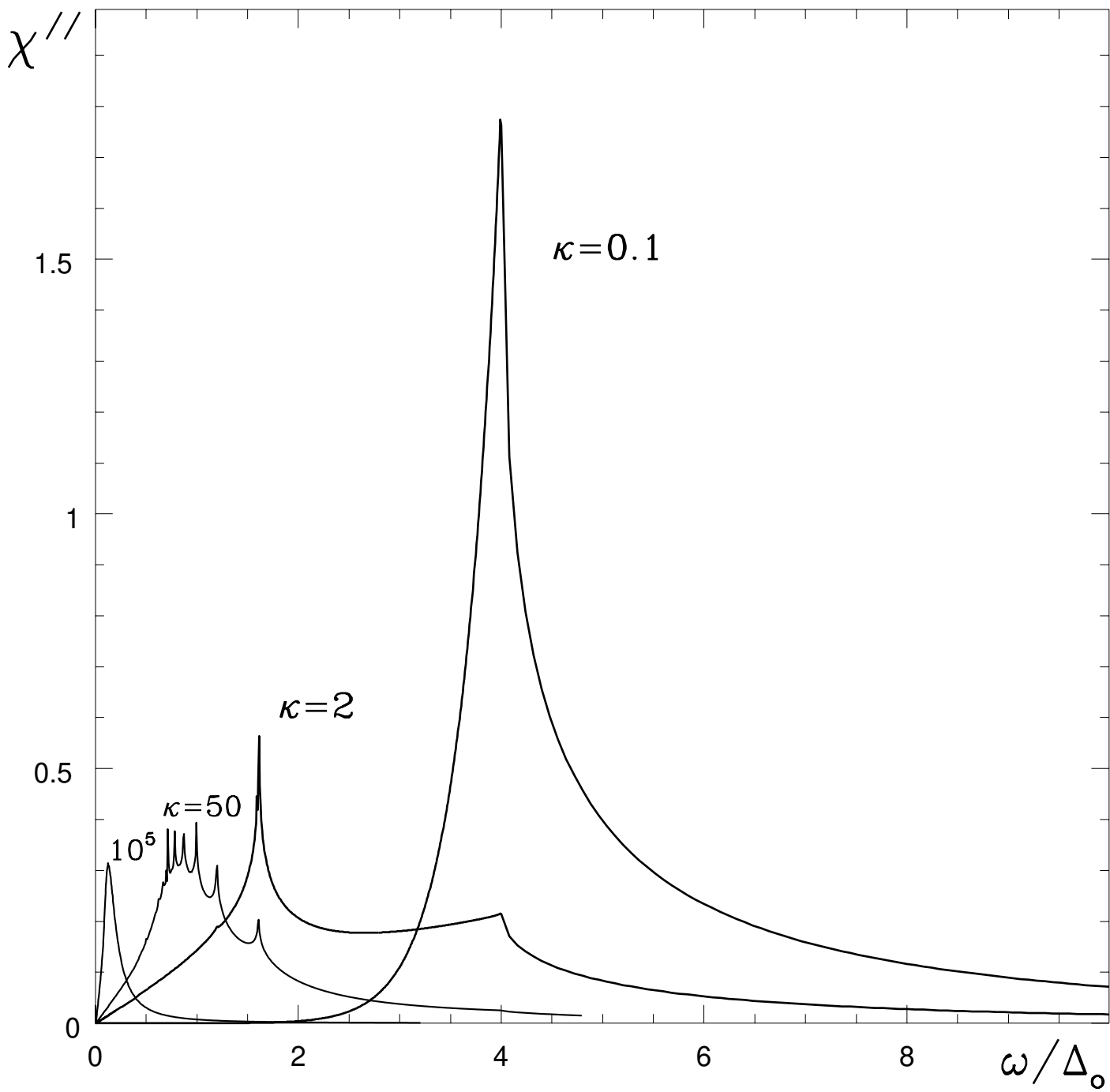

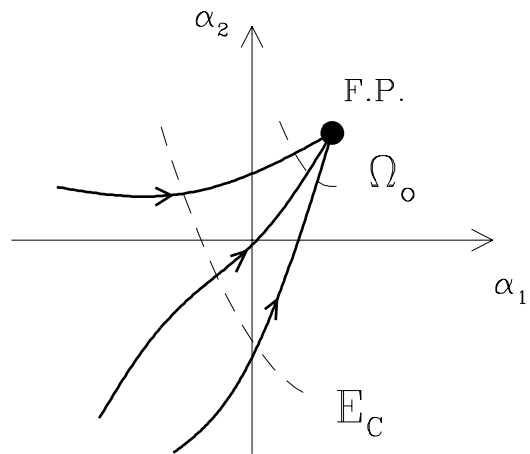
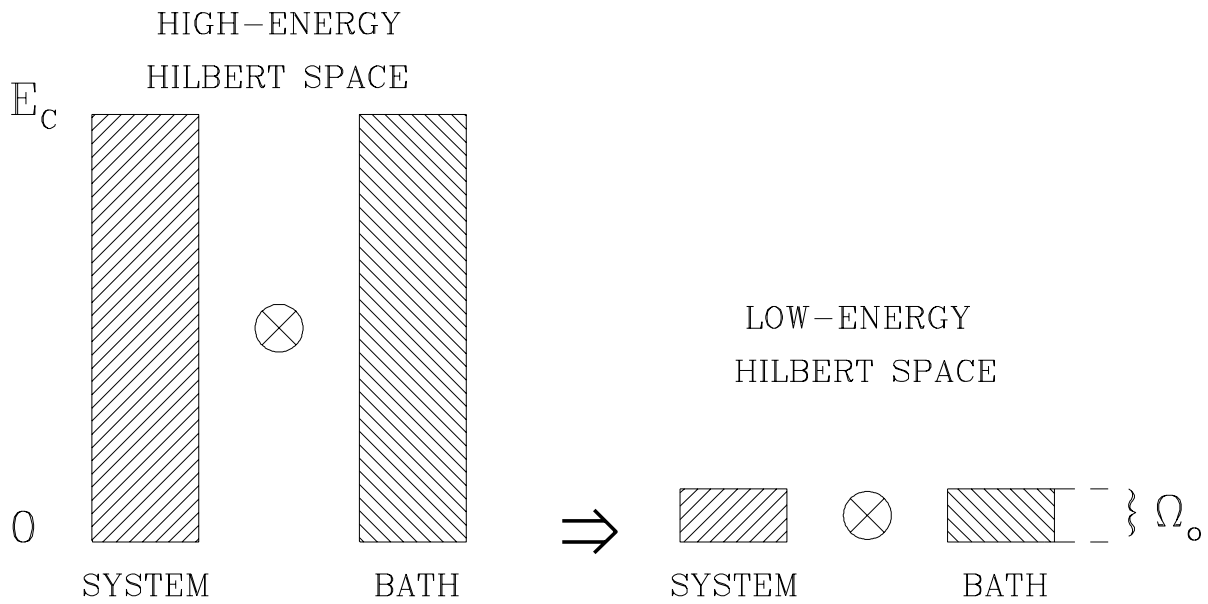

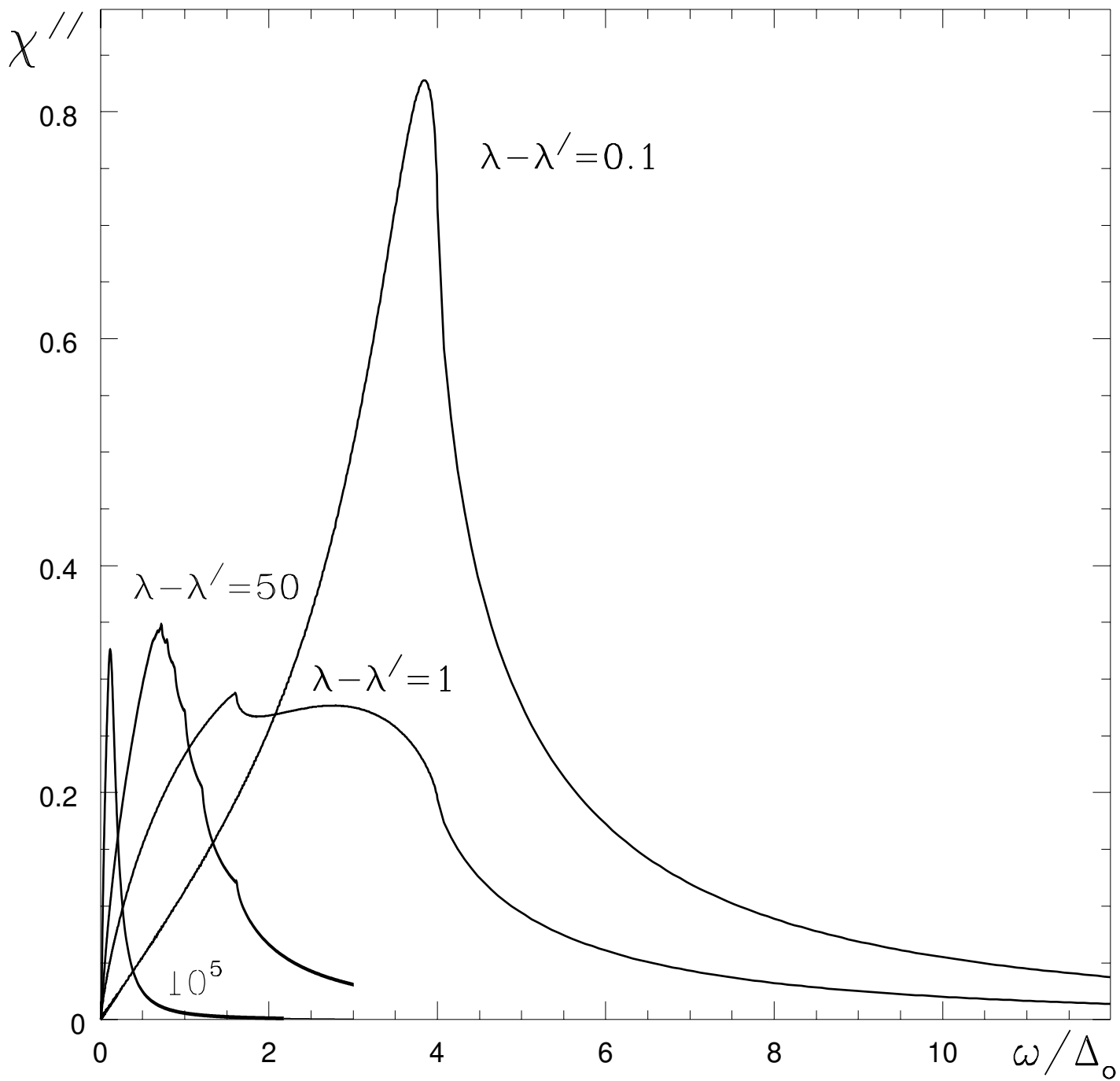

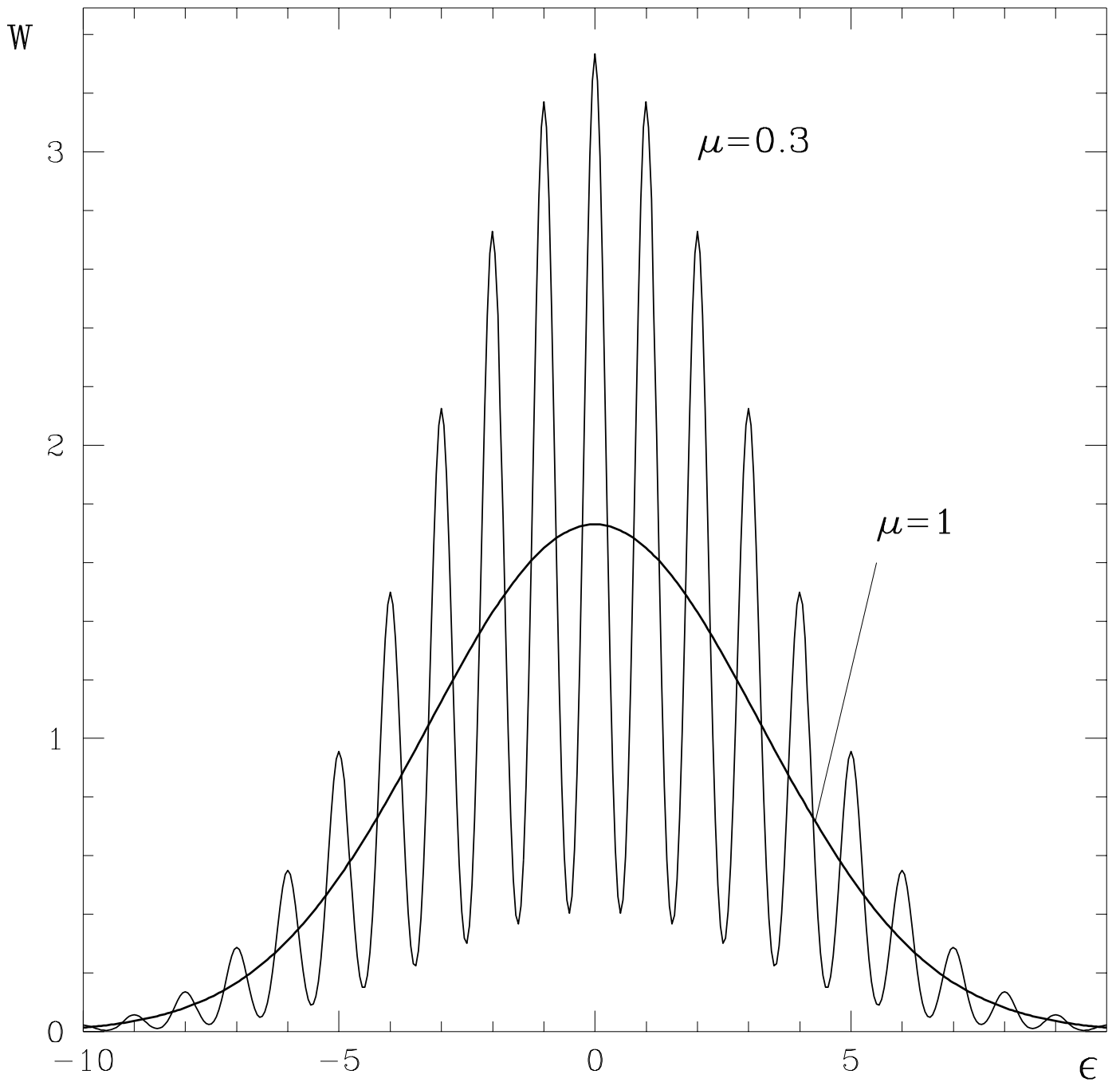

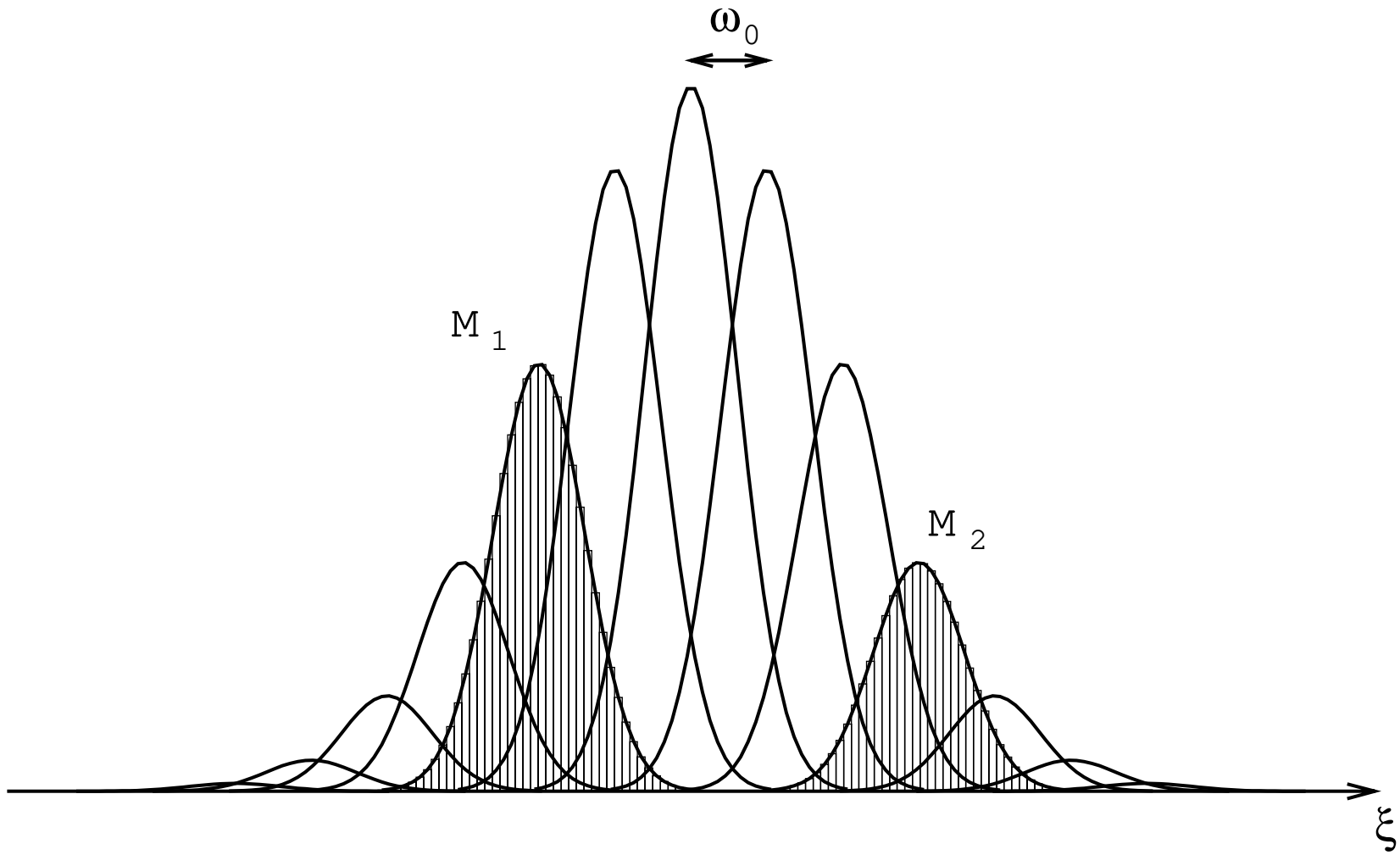

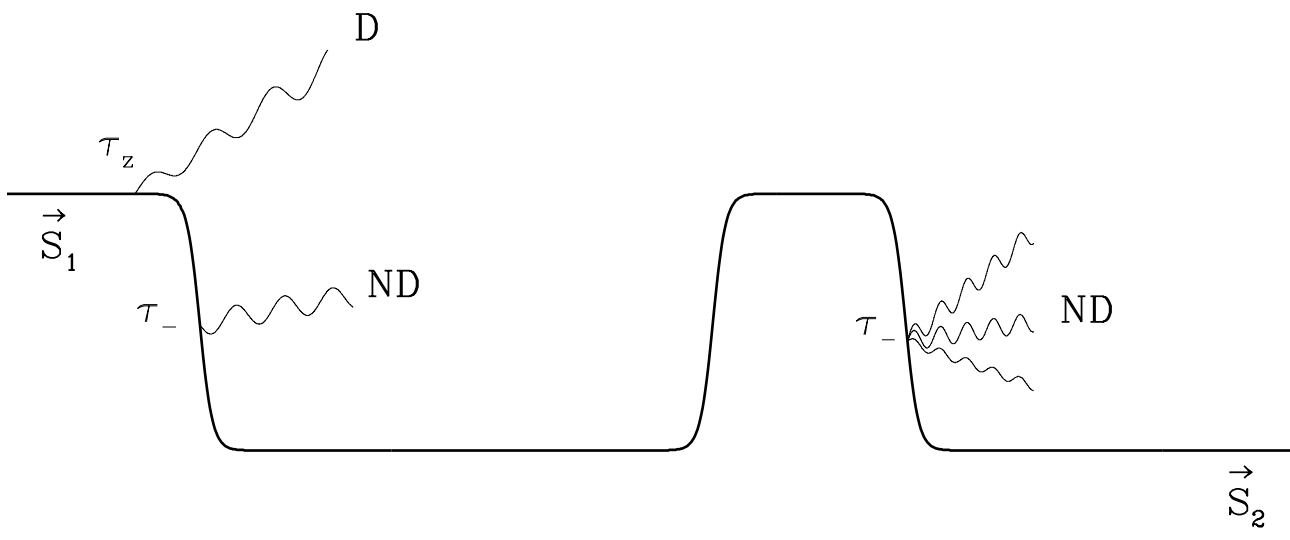

$P_{11} - 1/2$

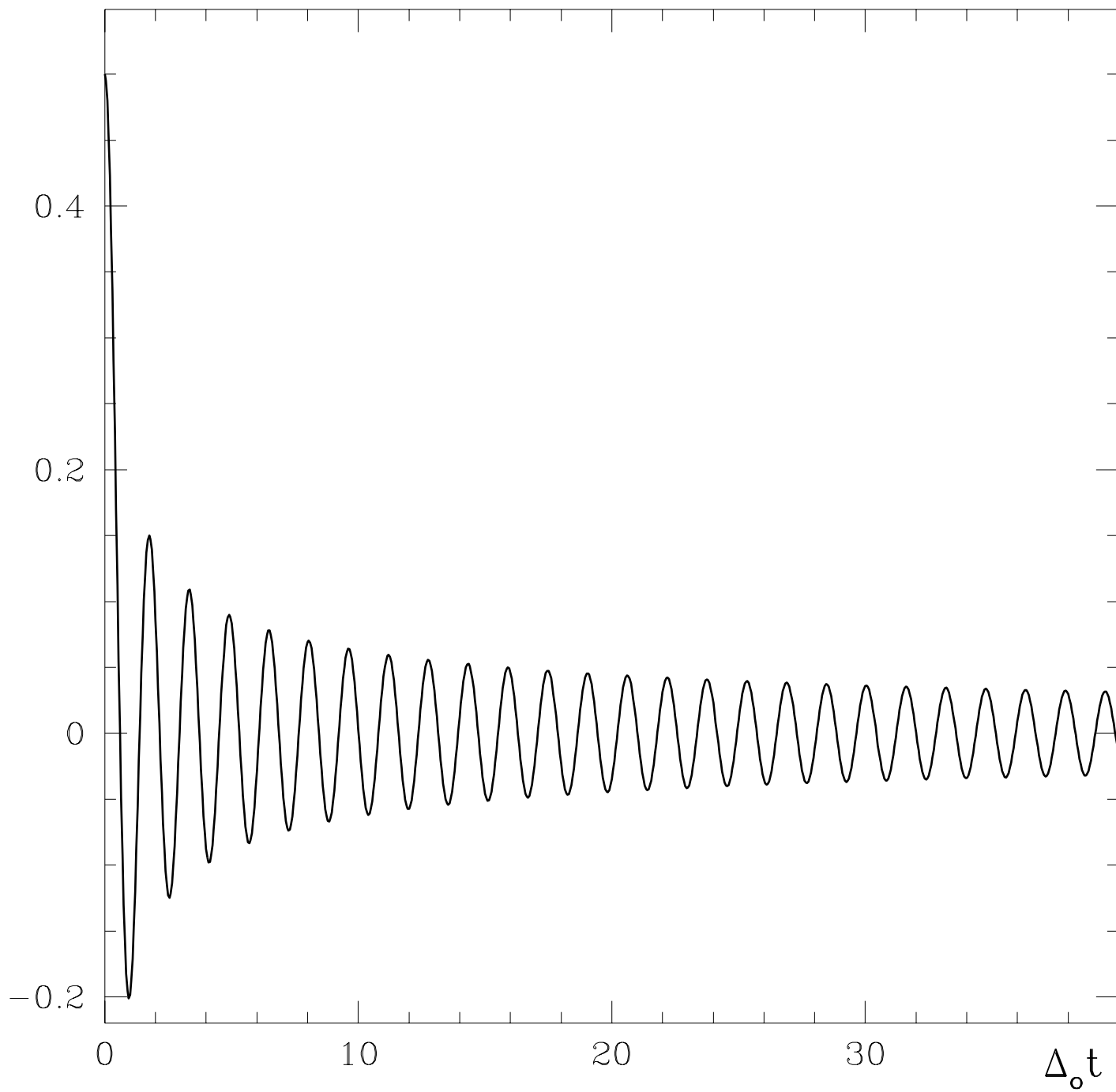

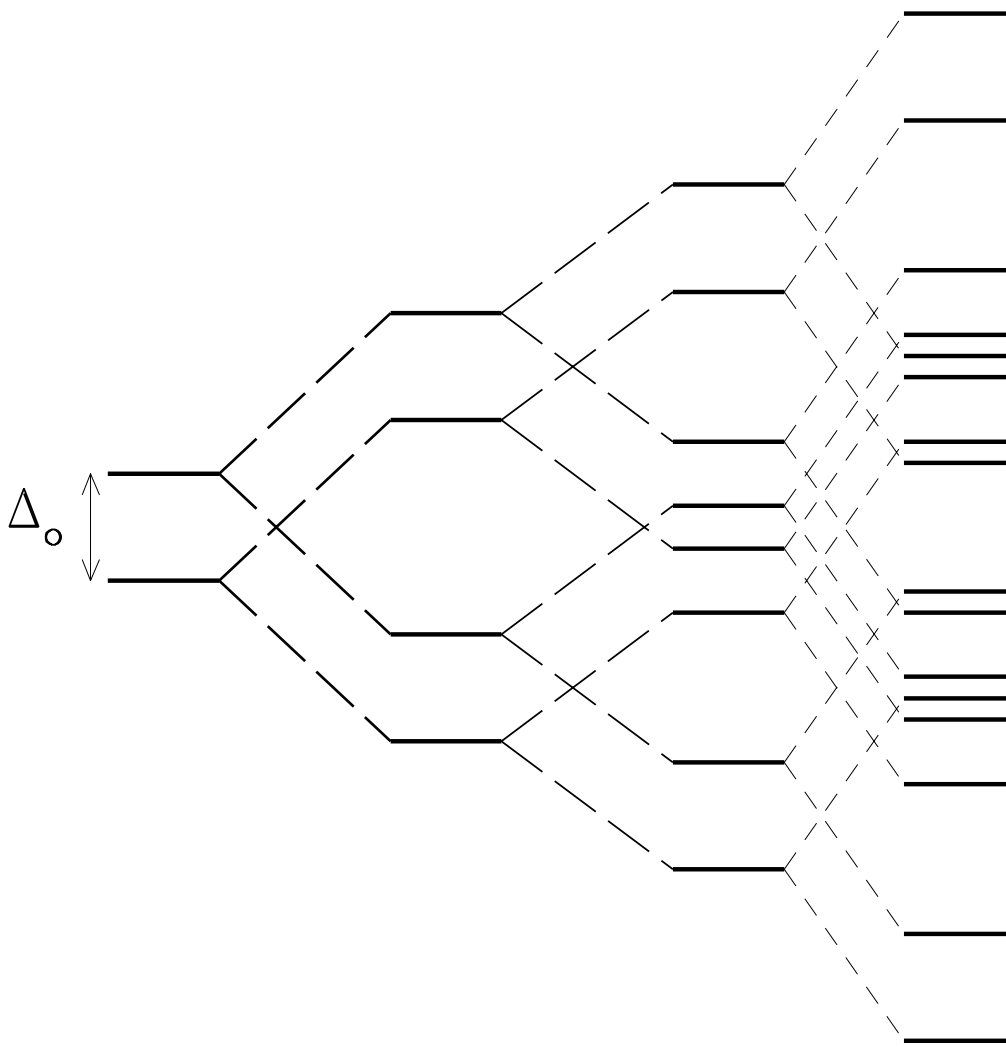

etc.

