

# A Large-Scale Database and Predictive Model of Listener-Rated Ease of Speech Understanding in Commercial Hearing Aids

Andrew Sabin , Steve Taddei , and Abram Bailey  
HearAdvisor, {andy, steve, abram}@hearadvisor.com

June 2026

## Abstract

HearAdvisor aims to provide hearing-aid consumers with audio-performance metrics and recordings that reflect real listening experience. For speech-related metrics, HearAdvisor has historically used HASPIv2, a metric designed to predict objective intelligibility and validated primarily under simulated distortions. Its relationship to consumer-rated ease of understanding for commercial hearing aids is uncertain. Here we introduce a large-scale perceptual dataset and learned metric for listener-rated perceived benefit for speech understanding. Website visitors with self-reported hearing loss completed a blind, MUSHRA-inspired listening test in which they rated recordings of commercial hearing aids on a five-point “Ease of Understanding” scale. The dataset contains 151,608 ratings, 104,298 after quality screening, spanning 10,394 binaural acoustic-manikin recordings from 83 commercial products across 72 realistic acoustic scenes. To predict these ratings, we pass aided audio and a matched clean-speech reference through a frozen Whisper encoder, subtract their internal representations, and train a small MLP head on the resulting difference embedding. On devices held out of training, the learned metric substantially outperforms HASPIv2 at the scene level (overall  $r = 0.92$  vs.  $0.83$ ; loud =  $0.89$  vs.  $0.75$ ; quiet =  $0.79$  vs.  $0.58$ ). In loud scenes, performance reaches the split-half reliability of the listener ratings; in quiet scenes, it approaches that ceiling. The model also responds sensibly to controlled gain and SNR manipulations. Together, the dataset and model provide a new way to predict listener-rated ease of speech understanding for real commercial hearing-aid recordings.

## 1 Introduction

HearAdvisor is an independent laboratory with the goal of providing meaningful audio performance information to hearing technology consumers. A series of metrics, audio files, and summary scores are derived from Kemar manikin recordings for each device and published online.

Overall, the quality of the information we provide to consumers is bounded by the extent to which the metrics we report reflect true user preferences. The most important metric, as rated by both consumers and clinicians (see Sabin et al., 2023), is the speech-understanding benefit across quiet and noisy environments. Here we propose a new speech metric that is based on (a) our recording database of many commercial hearing aids and (b) the preferences of the hearing-aid consumers who visit our website.

The speech metrics on our website have historically been derived from the Hearing-Aid Speech Perception Index, version 2 (HASPIv2; Kates and Arehart, 2021), a widely used model that estimates sentence-level objective intelligibility for listeners with impaired hearing. HASPIv2 models the impaired auditory periphery and can accurately predict objective intelligibility under a wide range of simulated distortions. It is less clear, however, (a) how well HASPIv2 predicts listener performance across a span of real commercial devices and (b) how a change in HASPIv2 relates to a change in the user’s actual perceived benefit. Understanding both of these issues is core to HearAdvisor’s goal of providing meaningful audio performance information to consumers.

Recently, speech foundation models (large pretrained models that learn general-purpose representations of speech, such as Automatic Speech Recognition (ASR)) have been increasingly used as feature extractors for intelligibility prediction. The Clarity Prediction Challenge (Barker et al., 2022) has shown that models receiving the intermediate representations of ASR-based speech foundation models can outperform HASPIv2 at predicting sentence-level intelligibility for hearing-impaired listeners (e.g., Yu et al., 2025, the winning submission). However, as with HASPIv2, these evaluations did not use commercial hearing aids and focus only on objective intelligibility.

Here we report a newly collected dataset of listener-rated *ease of speech understanding* for our large database of commercial hearing-aid recordings, together with a model that predicts those ratings directly from audio.

The dataset comprises over 151,000 ratings from website visitors with self-reported hearing loss, who judged how easy speech was to understand on recordings of real commercial devices across 72 spatially-realistic acoustic scenes. To predict these ratings, we pass each aided recording and a matched clean-speech reference through a frozen ASR foundation model (Whisper; Radford et al., 2023) and subtract their internal representations to form a “difference” embedding, which we map to a predicted rating with a small trained Multilayer Perceptron (MLP) head. On devices held out of training the model (1) tracks human ratings closely (device-level  $r = 0.91$  in loud scenes, 0.85 in quiet), (2) substantially outperforms HASPIv2 at predicting ratings, and (3) responds in sensible ways to controlled changes in audibility and signal-to-noise ratio. Unlike the prior intelligibility models described above, it is grounded in recordings of real commercial devices and targets the perceived, subjective benefit reported by real hearing-aid consumers.

## 2 The listening-test dataset

The recording pipeline, fitting decisions, and scoring methodology summarized here are set out in full in our original whitepaper (Sabin et al., 2023) and subsequent work (e.g., Manchaiah et al., 2024). Here we recap only the elements relevant to this study.

### 2.1 Device recordings and acoustic scenes

Each hearing aid is placed on a KEMAR acoustic manikin and programmed in two ways: an *initial* fit, approximating the most likely device settings (e.g., a manufacturer first fit), and a *tuned* fit, adjusted as closely as possible to NAL-NL2 prescriptive gain targets for experienced users (Keidser et al., 2011). For both fits, we use the standard N3 moderately sloping audiogram (Bisgaard et al., 2010). We chose this loss because it approximates the median hearing-aid consumer. The manikin was positioned at the center of an eight-loudspeaker ring in a purpose-built acoustic test laboratory. Twelve everyday acoustic environments from the Ambisonic Recordings of Typical Environments (ARTE) database were decoded to eight channels and reproduced in the lab at the published sound levels (Weisser et al., 2019). Target talkers were recorded separately while listening to the corresponding environment, to attempt to elicit the Lombard effect (Lombard, 1911), and were convolved with the impulse responses in the ARTE database. The speech-to-noise ratio of each scene was set from each environment’s real-world sound level, following the level-to-SNR relationship measured for hearing-impaired listeners in daily life (Wu et al., 2018). Scenes are presented as one talker in front (0 deg), two talkers to each side ( $\pm 45$  deg), or three talkers spread across the front ( $\pm 45$  deg and 0 deg), with

two talker sets per configuration. This yields six talker configurations across twelve background environments, for a total of 72 scenes per device. We group the twelve backgrounds into *loud* ( $> 70$  dB SPL; 7 backgrounds) and *quiet* ( $< 70$  dB SPL; 5 backgrounds) scene types, which behave differently throughout the analysis. All manikin recordings are diffuse-field equalized to make them suitable for presentation over headphones or speakers.

### 2.2 The Blind Listening Challenge

Human judgments of these recordings are collected through a web app on [HearAdvisor.com](https://HearAdvisor.com) called the *Blind Listening Challenge*, embedded on each product and comparison page.

**Coarse Calibration.** Listeners are instructed to remove their hearing aids and listen through their best headphones or speakers. They then perform a coarse level calibration in which they adjust a restaurant-ambiance clip until it sounds realistic. We use a convention where 0 dB FS = 100 dB SPL and assume (based on pilot testing) that on average listeners place this around 70 dB SPL (i.e.,  $-30$  dB FS). Listeners are told not to adjust their system volume after this step, because all subsequent files follow this mapping.

**Rating.** The listener then rates sets of hearing aids in three scenes using a method inspired by the MUSHRA paradigm for subjective audio quality (ITU-R, 2015). On each screen the listener is presented with recordings of six unlabeled hearing aids, each recorded in the *identical* acoustic scene. Switching between sliders changes the device under audition. For each file, the listener uses the slider to rate how easy the speech is to understand on a five-point (0–4) scale from “Really Hard” to “Really Easy.” We therefore call this measure *ease of speech understanding*.

**Anchors and normalization.** As in MUSHRA, hidden anchors are used to improve data quality. Two of the six items on each screen are hidden anchors synthesized offline. The *good* anchor meets NAL-NL2 gain targets exactly and adds a 6 dB improvement in signal-to-noise ratio (SNR) via noise-only attenuation; the *bad* anchor is low-pass filtered at 1 kHz with no SNR improvement. The anchors serve two purposes. First, they serve as a quality-control gate: we discard a session if the listener does not rate the good anchor at least one point above the bad anchor. Second, they serve as a normalization scale. Within each session we linearly rescale every rating so that the session’s mean bad- and good-anchor ratings match the global mean bad- and good-anchor ratings for the same scenes. These transformations remove per-listener scale drift while preserving genuine differences in

anchor quality across scenes. The remaining four items on each screen are real recordings. One is the device whose page the listener entered from; the other three are randomly chosen devices. The three tested scenes are also chosen randomly. After the third scene the listener is unblinded to which devices were rated and shown their average ratings.

### 2.3 Participants and quality control

The test is taken anonymously online, and we treat each completed session as one participant. Across the 6,600 sessions collected since the feature launched (November 2025 – June 2026), self-reported hearing loss is most often moderate (66%), followed by severe (17%), mild (15%), and profound (2%). Listeners are split across loudspeakers (41%), headphones (34%), and hearing aids (25%), and together contribute roughly 151,000 individual ratings.

We then apply two filters (Table 1). *(i) Listener inclusion.* We keep only mild, moderate, or severe hearing loss auditioned over headphones or loudspeakers. We exclude profound loss, whose ratings were observed to be systematically atypical. We also exclude listeners monitoring through their own hearing aids, whose judgments are markedly less reliable and who are in any case asked to remove them (6,600  $\rightarrow$  4,878 sessions). *(ii) Anchor-based screening.* We discard any session in which the mean *good*-anchor rating does not exceed the mean *bad*-anchor rating by at least one point, since a listener who cannot order the two obvious anchors was not performing the task (4,878  $\rightarrow$  3,468 sessions, 104,298 ratings total).

**Data aggregation.** To improve data quality, we aggregate data across scenes with the same background. Specifically, we train the model on pooled ratings across all talker configurations that share the same background. At present, each individual recording is rated by a median of only 6 listeners—potentially too few for a stable target. We therefore model at the background level, pooling the six talker configurations within each device $\times$ background $\times$ fit. This aggregation raises the median number of ratings per target to 33. We treat those six recordings as one composite measurement—a *talker-pooled scene-level target*—for that device, fit, and background. The pooling is justified by the high agreement across talker conditions. The six configurations rate these targets consistently (Cronbach’s  $\alpha = 0.90$ ), so combining them sharpens the quality estimate rather than discarding real signal. Each target is the rating-count-weighted mean of all its ratings, and the six talker recordings enter as separate model inputs, all labelled with that shared target score. This yields 1,764 talker-pooled scene-level targets, trained from 10,394 recordings, spanning 150 device–fits drawn from 83 distinct products tested.

**Table 1:** Participants, quality control, and dataset.

Quantity	Value
Listening sessions collected	6,600
after screening	3,468
Ratings collected	151,608
after screening	104,298
Audio recordings	10,394
Talker-pooled scene-level targets	1,764
Distinct products tested	83
Fits per device	2

## 3 Method

### 3.1 Learned ease of speech understanding metric

We start from a large pre-trained speech-to-text model and train only a relatively small MLP head for our task (Fig. 1). We use the encoder of Whisper-small (244M parameters; Radford et al., 2023), kept frozen. We extract features *intrusively*: the processed (aided) audio and the matched clean reference speech (without added noise) are each downmixed to mono (the Whisper encoder operates on a single channel) and fed separately into the encoder. We mean-pool the encoder hidden states over time to a single 768-dimensional vector for each signal. We then compute a difference representation by subtracting the clean-reference embedding from the aided-audio embedding,

$$\mathbf{x} = \text{enc}_\ell(\text{aided}) - \text{enc}_\ell(\text{clean}), \quad (1)$$

so that the representation reflects the transformation introduced by the device rather than the content of the utterance. The difference embedding is fed into a small multilayer perceptron (768  $\rightarrow$  768  $\rightarrow$  384  $\rightarrow$  1 with layer normalization, GELU activations and dropout;  $\approx 0.89\text{M}$  trainable parameters per head) that maps  $\mathbf{x}$  to a predicted mean opinion score. The model is trained at the talker-pooled scene level (§2.3): the six talker recordings of a scene-level target share that target as their label, so the head sees all six as separate examples.

We found empirically that different encoder layers  $\ell$  suit different background types: a mid-level layer (layer 5) is best for loud scenes, while an earlier layer (layer 2) is best for quiet scenes. The metric therefore routes each file by background level (layer 2 below 70 dB SPL, layer 5 above), using a separately trained head for each route.

### 3.2 Training objective

Only the two MLP heads, one for loud scenes and one for quiet, are trained; the Whisper encoder is frozen throughout. The training loss is a weighted mean-squared error: each target is weighted by the square root of the number of ratings behind it (the scene-level target’s total rating

count), so that better-supported targets count more. We optimize with AdamW (learning rate  $10^{-3}$ , weight decay  $10^{-4}$ ) for 200 epochs. Because a single small head is sensitive to its random starting point, each route’s prediction is averaged over five heads trained from different random seeds (ten heads in total, five per route).

### 3.3 Baseline

We compare against HASPIv2 (Kates and Arehart, 2021), the intelligibility metric currently used for our published speech scores. Like our model it is reference-based (i.e., intrusive); it was computed using the standard N3 audiogram (Bisgaard et al., 2010), the same moderately sloping loss targeted by all device fittings. To keep the comparison fair, HASPIv2 is evaluated at the same talker-pooled scene level as our model. An important caveat is that HASPIv2 predicts *objective* intelligibility, whereas our listeners rate *ease of speech understanding*, a subjective judgment related to intelligibility but distinct from it, and one that may also reflect listening effort and overall sound quality. The comparison quantifies how much is gained by learning from this database rather than criticising HASPIv2 on a task it was not designed for.

## 4 Experiments and results

### 4.1 Predicting held-out devices

We plot each metric (HASPIv2 and the proposed model) against the human mean listener rating at the talker-pooled scene level (Fig. 2) defined in §2.3. Unless noted, all correlations for our model are computed on devices *held out of training* (a device’s initial and tuned variants

held out together). HASPIv2 (Fig. 2, left) correlates moderately with the ratings overall ( $r = 0.83$ ) and in loud scenes (0.75), but more weakly in quiet scenes ( $r = 0.58$ ). As expected, it also shows saturation at both ends of the scale (0 and 1 proportion correct). The proposed model (Fig. 2, right) tracks ratings much more closely at all levels (all  $r = 0.92$ , loud  $r = 0.89$ , quiet  $r = 0.79$ ).

Because each rating average is itself a noisy estimate of true quality, the achievable correlation is bounded by the reliability of the ratings. We estimate this ceiling by split-half reliability: each scene-level target’s ratings are split in two, the half-means are correlated across targets, Spearman–Brown corrected, and averaged over 1,000 splits. The model effectively reaches this ceiling in loud scenes (model  $r = 0.89$  vs. ceiling  $r = 0.89$ ), agreeing with the mean ratings about as well as independent samples of listeners agree with each other. Quiet scenes do not quite reach the ceiling (model  $r = 0.79$  vs. ceiling  $r = 0.85$ ).

The talker-pooled scenes are the level the model is trained on, but HearAdvisor reports scores to consumers at two coarser levels: per *fit* (a device at one fit setting) and per *device* (averaging over both fits). Aggregating the held-out scene-level predictions and targets to these levels raises the correlations, as averaging cancels scene-to-scene noise. At the fit level the proposed model reaches  $r = 0.88$  in loud scenes and 0.81 in quiet; at the device level it reaches  $r = 0.91$  and 0.85, respectively.

### 4.2 Sensitivity to controlled manipulations

To probe what the model has learned, we synthesized hearing-aid signals offline and passed them through the

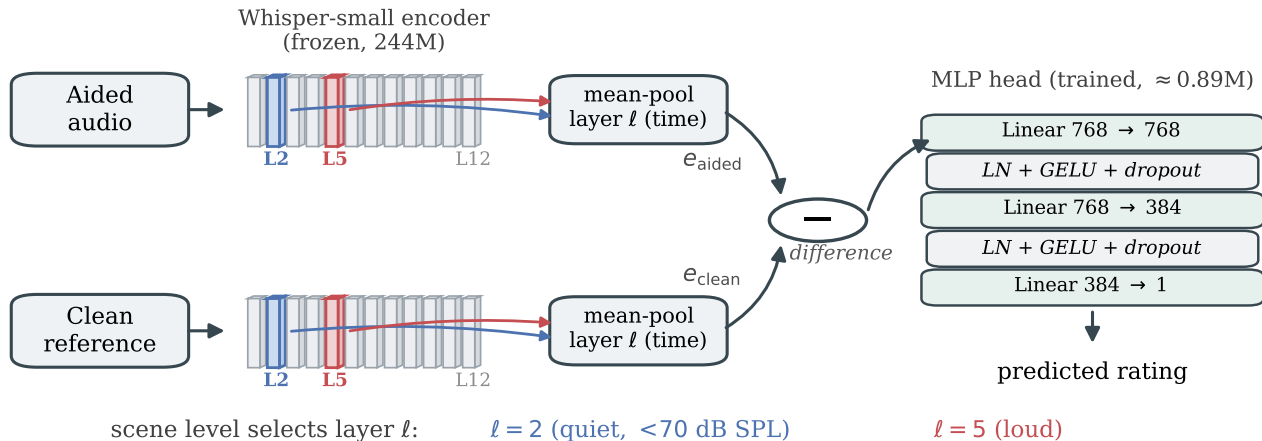

**Figure 1:** Model overview. Processed (aided) audio and a matched clean reference pass through the same frozen 12-layer Whisper-small encoder; the selected layer’s hidden states are mean-pooled over time and differenced to form a 768-D difference embedding, which the trained MLP head maps to a predicted rating. Scene level selects the encoder layer (blue: layer 2, quiet; red: layer 5, loud).

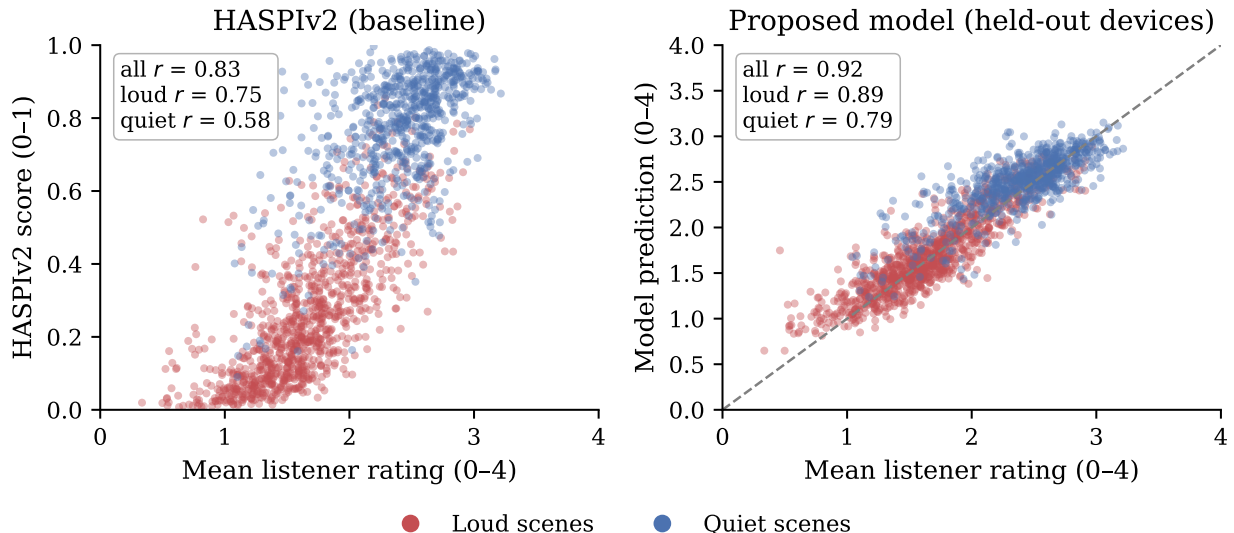

**Figure 2:** Each metric versus the mean listener rating of ease of speech understanding at the talker-pooled scene level, colored by scene type. **Left:** HASPIv2 correlates moderately in loud scenes and weakly in quiet scenes. **Right:** the learned metric, on devices held out of training, tracks the human ratings closely.

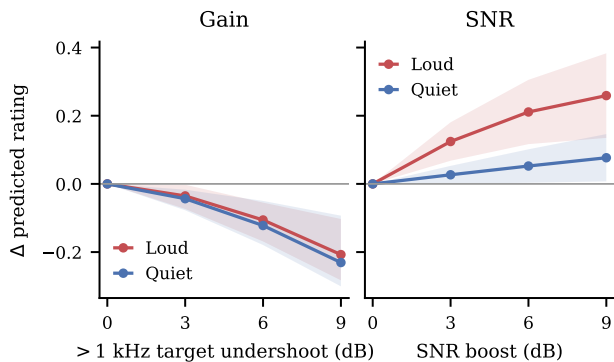

**Figure 3:** Change in predicted ease of speech understanding as synthetic devices undershoot the NAL-NL2 gain target (left) or receive an SNR boost via noise attenuation (right). Gain undershoot hurts both scene types; added SNR helps mainly in loud scenes. Bands show the spread across scenes.

production-trained (all-data) model while varying two interpretable dimensions: (1) fit-to-target gain, by intentionally undershooting the NAL-NL2 target above 1 kHz, and (2) SNR, by attenuating the noise only (not the speech). The influence of these manipulations on the model’s relative output is shown in Fig. 3. Undershooting prescribed gain targets (left) is penalized in both scene types. Boosting SNR, however, helps much more in loud scenes than in quiet ones (right). This is expected given that quiet scenes, unlike loud ones, already have favorable SNRs (Wu et al., 2018) and are likely limited by audibility rather than noise.

## 5 Conclusion

We have presented a large-scale perceptual database of listener-rated ease of speech understanding for recordings of commercial hearing aids, and shown that these judgments can be predicted directly from a model trained on manikin recordings. A small MLP head on a frozen speech-recognition model predicts mean opinion score on held-out devices well ( $r = 0.89$  in loud scenes,  $0.79$  in quiet) and better than the objective intelligibility metric we currently use (HASPIv2,  $r = 0.75$  and  $0.58$ , respectively). The proposed model responds sensibly to controlled gain and SNR manipulations. Its prediction quality reaches the estimated noise ceiling of user responses in loud scenes, and approaches it in quiet scenes.

The training data are unusually representative where it matters most to our goal. The device sample is broad for this market: 83 commercial products, from premium prescription flagship products to entry-level over-the-counter devices. Every one was recorded and rated under the same protocol. Ratings come from organic users of our website—likely actual consumers of hearing assistance devices. Coverage of acoustic environments is lighter. There are twelve backgrounds and six talker configurations. Expanding this range with new recordings is an active area of our future work.

While these initial results are promising, we acknowledge other limitations. First, we target a single standard N3 audiogram, chosen to approximate the median hearing-aid consumer. How the proposed model generalizes to other degrees and types of hearing loss is untested. Second, the data-collection setting is uncontrolled: the sample is self-selected, the playback hardware varies, and the calibration is coarse. We expect many of these

factors to average out across the scale of the dataset, but we have not directly quantified their effect.

Overall, the dataset described here captures the judgments of thousands of hearing-aid consumers on real commercial devices in realistic acoustic scenes. The proposed model trained on that dataset predicts those judgments about as well as the judgments replicate across independent listener samples (§4). We believe this metric, once integrated into our website, brings us closer to our goal of communicating meaningful performance information to hearing-aid consumers.

## References

- J. Barker, M. A. Akeroyd, T. J. Cox, J. F. Culling, J. Firth, S. Graetzer, H. Griffiths, L. Harris, G. Naylor, Z. Podwinska, E. Porter, and R. Viveros Muñoz. The 1st Clarity Prediction Challenge: A machine learning challenge for hearing aid intelligibility prediction. *Proc. Interspeech*, pages 3508–3512, 2022.
- N. Bisgaard, M. S. Vlaming, and M. Dahlquist. Standard audiograms for the IEC 60118-15 measurement procedure. *Trends in Amplification*, 14(2):113–120, 2010.
- ITU-R. Recommendation BS.1534-3: Method for the subjective assessment of intermediate quality level of audio systems. International Telecommunication Union, Geneva, 2015.
- J. M. Kates and K. H. Arehart. The Hearing-Aid Speech Perception Index (HASPI) version 2. *Speech Communication*, 131:35–46, 2021.
- G. Keidser, H. Dillon, M. Flax, T. Ching, and S. Brewer. The NAL-NL2 prescription procedure. *Audiology Research*, 1(1):e24, 88–90, 2011.
- É. Lombard. Le signe de l’élévation de la voix. *Annales des Maladies de l’Oreille et du Larynx*, 37:101–119, 1911.
- V. Manchaiah, S. Taddei, A. Bailey, D. W. Swanepoel, H. Rodrigo, and A. Sabin. A novel consumer-centric metric for evaluating hearing device audio performance. *Frontiers in Audiology and Otology*, 2:1406362, 2024.
- A. Radford, J. W. Kim, T. Xu, G. Brockman, C. McLeavey, and I. Sutskever. Robust speech recognition via large-scale weak supervision. In *Proc. ICML*, volume 202 of *PMLR*, pages 28492–28518, 2023.
- A. Sabin, S. Taddei, and A. Bailey. HearAdvisor procedures for recording and evaluating hearing devices v1.0. White paper, OSF Preprints, 2023. <https://doi.org/10.31219/osf.io/trnga>.
- A. Weisser, J. M. Buchholz, C. Oreinos, J. Williges, J. Galloway, T. Humburg, T. Galloway, and H. Dillon. The Ambisonic Recordings of Typical Environments (ARTE) database. *Acta Acustica united with Acustica*, 105(4):695–713, 2019.
- Y.-H. Wu, E. Stangl, O. Chipara, S. S. Hasan, A. Welhaven, and J. Oleson. Characteristics of real-world signal-to-noise ratios and speech listening situations of older adults with mild-to-moderate hearing loss. *Ear and Hearing*, 39(2):293–304, 2018.
- H. Yu, H. Zhou, L. Li, B. Cao, C. Mo, and S. X. Wang. Intrusive intelligibility prediction with ASR encoders. In *Proc. 3rd Clarity Prediction Challenge (CPC3)*, 2025.