

Memory-Centric Computing: Security Benefits and Challenges of Processing-in-DRAM

İsmail Emir Yüksel F. Nisa Bostancı Ataberk Olgun Onur Mutlu

SAFARI Research Group
ETH Zürich

Today’s computing systems are processor-centric: they require frequent data movement between processing elements (e.g., CPU) and main memory (DRAM), leading to significant inefficiencies in performance and energy consumption. Memory-centric computing instead moves computation to the data, enabling computation capability in and near all places where data is generated and stored, and greatly reducing the performance and energy overheads of data access and data movement. This shift from a processor-centric to a memory-centric paradigm has important and underexplored consequences for system security. Turning memory from a dumb, inactive store into an active computing substrate introduces benefits as well as challenges for system security: it can provide new in-memory security primitives and also reduce data exposure, but it can also expose new attack surfaces.

This work discusses the security benefits and challenges of memory-centric computing, specifically Processing-in-DRAM (PiD), a paradigm where the operational characteristics of a DRAM chip are exploited and enhanced to perform computation on data stored in DRAM. Specifically, we describe 1) new state-of-the-art DRAM-based true random number generators that provide up to 16.05 Gb/s throughput and physical unclonable functions with 5.75% lower evaluation latency than the prior state-of-the-art, both on off-the-shelf DRAM chips and 2) two key security challenges of PiD: amplified DRAM read disturbance (e.g., 158x reduction in the minimum number of DRAM accesses required to induce the first bitflip) and high throughput memory timing channels (e.g., a communication throughput of 14.8Mb/s). We believe it is time to design, use, and program DRAM, and in general memory, not as an inactive storage substrate, but as a combined computation, storage, and security substrate, where computational capability, storage density, and security are all key goals.

1. Security of Memory-Centric Computing

Modern computing systems are *processor-centric*. In this paradigm, memory is treated as a dumb, inactive component: it serves the load and store requests of processing units (e.g., CPU, GPU, TPU, FPGA, ASIC), but cannot operate on the data it holds or manage itself. Computation can therefore happen *only* after data moves across the memory hierarchy to the processor. Such data movement is far more costly than computation, in terms of energy, latency, and bandwidth [1–5]. With the increasingly data-centric nature of contemporary and emerging applications such as generative artificial intelligence, large machine learning models, genome analysis, and video an-

alytics, memory becomes an even larger performance, energy, robustness, and system scaling bottleneck in processor-centric computing systems [4, 6–37].

The *memory-centric computing* (MCC) paradigm [1, 2, 5, 38, 39] can fundamentally solve data movement bottlenecks. The key idea is to place computation mechanisms in or near where the data is stored (i.e., inside the memory chips, in the logic layer of 3D-stacked memory, in the memory controllers, inside large caches, inside storage units or inside sensing units), so that data movement between where the computation is done and where the data is stored is reduced or eliminated, compared to contemporary processor-centric systems [3, 4, 8, 17, 27, 28, 30, 34, 37, 40–122]. MCC can be implemented in (i.e., using or near) different memory technologies [1, 2, 5], including SRAM (e.g., [57, 58, 97–107, 123]), DRAM (e.g., [3, 4, 19, 22, 27–30, 34, 36, 37, 44–46, 48–53, 56, 60–63, 65, 71–78, 82, 84, 117–119, 124–184]), NAND flash (e.g., [20, 21, 68, 85–96, 185]), or emerging (e.g., [47, 54, 55, 64, 66, 69, 70, 80, 81, 83, 115, 186]). We focus on DRAM [187] due to its dominance as the main memory technology that can house large amounts of data. We broadly call MCC implemented in DRAM as *Processing-in-DRAM* (PiD). PiD greatly reduces the performance and energy overheads of data access and data movement, and provides other benefits, e.g., improving system security and reducing system complexity.

PiD can improve system security by providing new in-DRAM security primitives, reducing exposure of security-critical data, and accelerating security workloads (e.g., fully homomorphic encryption (FHE) [101, 188–195]). A growing body of work demonstrates that real, unmodified commercial off-the-shelf DRAM chips can provide two key security primitives: by carefully violating DRAM access timing parameters and taking advantage of the resulting characteristics of different DRAM cells (i.e., whether they always/never fail or fail randomly), it is possible to use DRAM to create physical unclonable functions (PUFs) and true random number generators (TRNGs) at high throughput and low latency [71–74, 82, 118, 196–218], accelerating secure computation (FHE).

Unfortunately, PiD can also create new attack surfaces. Since PiD provides a direct, fast way to access and operate on memory, it can cause robustness (i.e., safety, security, reliability, availability) issues and unforeseen information leakage. Recent works demonstrate two such risks [219, 220]. First, Processing-in-DRAM (i.e., using DRAM cells to perform computation) relies on multiple-row activation, where multiple rows are activated either simultaneously or in quick succession, which can exacerbate DRAM read disturbance vulnerabilities [221–223].

Second, processing-in-memory provides direct main memory access to userspace applications such that they can bypass the cache hierarchy, which can be exploited to establish high throughput covert and side channels through the shared DRAM row buffer [220].

In this paper, we describe examples from both security benefits and security challenges of Processing-in-DRAM. For security benefits, we cover 1) the state-of-the-art DRAM-based TRNG, SiMRA-TRNG [118] and 2) the state-of-the-art DRAM-based PUF, SiMRA-PUF [218]. For security challenges, we cover 1) a recent experimental study on read disturbance effects of Processing-in-DRAM, PuDHammer [219], and 2) a set of high throughput main memory-based timing attacks that exploit the characteristics of Processing-in-DRAM, IMPACT [220].

We believe that the future of memory-centric systems is very bright and promising, yet many exciting challenges remain to be solved across the computing stack to enable their *secure, widespread, and easy* adoption.

2. Security Benefits of Processing-in-DRAM: In-DRAM Security Primitives

Secure computation is of critical importance in modern computing systems. Therefore, it is important for a memory-centric system to support fundamental security primitives that enable secure computation and security functions. Doing so would enable memory-centric systems to execute a wider range of workloads securely. We focus on two key security primitives that DRAM provides: 1) true random number generation and 2) physical unclonable functions.

2.1. In-DRAM True Random Number Generation

Random number generators (RNGs) are critical components in many different applications, including cryptography, scientific simulation, industrial testing, and recreational entertainment [224–236]. In particular, for modern cryptographic applications, a random number generator is critical to prevent information leakage to a potential adversary [229–237]. RNGs are broadly classified into two categories [238–241]: pseudo-random number generators (PRNGs) [242–246], which deterministically generate numbers starting from a seed value to approximate a true random sequence, and true random number generators (TRNGs) [71, 72, 74, 118, 196–201, 209, 229, 247–269], which generate random numbers by sampling non-deterministic physical phenomena. An effective TRNG must 1) produce truly random numbers, 2) provide a high throughput of random numbers at low latency, and 3) be practically implementable at low cost.

DRAM offers a promising substrate for developing an effective and widely-available TRNG due to the prevalence of DRAM throughout all modern computing systems, ranging from microcontrollers to supercomputers. A high throughput DRAM-based TRNG would help enable widespread adoption of applications that are today limited to only select architectures equipped with dedicated high-performance TRNG engines. In addition to traditional computing paradigms, DRAM-based

TRNGs can benefit memory-centric systems: a low-latency, high throughput DRAM-based TRNG can enable memory-centric system applications to source random values directly within the memory itself, thereby enhancing the overall potential, security, and privacy of such architectures.

Prior DRAM-based TRNG designs use DRAM data retention failures [196, 197], DRAM startup values [198, 199], and non-determinism in DRAM command scheduling [201] to generate true random numbers. Unfortunately, these approaches do not fully satisfy these requirements because they either do not exploit a fundamentally non-deterministic entropy source (e.g., DRAM command scheduling) or are too slow for continuous high throughput operation (e.g., DRAM data retention failures, DRAM startup values).

Recent works [71, 72, 118] enable high throughput, low-latency true random number generation in commodity off-the-shelf DRAM chips by exploiting the failures induced by violating DRAM access timing parameters and activating multiple DRAM rows simultaneously. D-RaNGe [72] reduces the DRAM row activation latency below manufacturer-recommended specifications to induce activation failures and demonstrates that the resulting TRNG cells fail truly randomly. D-RaNGe [72] provides over two orders of magnitude higher throughput than the prior state-of-the-art DRAM-based TRNG at that time. QUAC-TRNG [71] activates four DRAM rows simultaneously, causing the bitline sense amplifiers to non-deterministically converge to random values, and achieves lower latency and higher throughput than D-RaNGe. The state-of-the-art DRAM-based TRNG, SiMRA-TRNG [118], generalizes quadruple-row activation [71] to simultaneous N-row activation [119], where N can be up to 32.

2.2. State-of-the-Art DRAM-based TRNG: SiMRA-TRNG

Key Idea. Fig. 1 shows the command sequence for true random number generation using SiMRA, with eight DRAM cells connected to a bitline. Initially, four cells have a voltage level of VDD, the remaining four are at ground (GND), and the bitline has a voltage level of VDD/2. To generate random numbers, SiMRA-TRNG issues one ACT→PRE→ACT command sequence with reduced DRAM timings. Doing so activates the cells simultaneously and enables charge sharing between them and their bitline. Hence, the bitline voltage is perturbed by the simultaneously activated cells, where some try to pull up the bitline voltage, and the others try to pull it down. As a result, these opposing contributions of simultaneously activated cells can randomly perturb the bitline from the reference voltage. The sense amplifier then kicks in and tries to amplify the voltage on the bitline, which results in sampling a random value based on the random perturbations on the bitline voltage.

Design. SiMRA-TRNG generates true random numbers using four banks in five steps: 1) selecting a high-entropy simultaneously activated row (SAR) group based on the characterization, 2) initializing the rows that are used to generate true random numbers by performing the RowClone operation [50, 56, 75, 119, 219] in quick succession, 3) performing

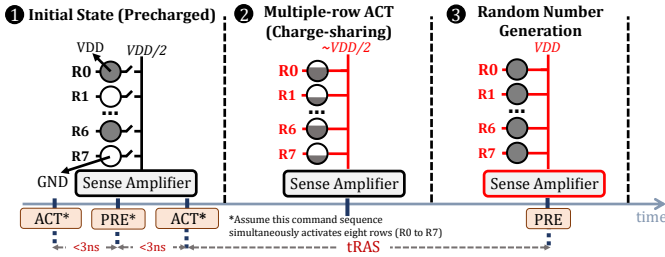

Figure 1: The command sequence for true random number generation using SiMRA. An ACT→PRE→ACT sequence simultaneously activates multiple rows; the opposing contributions of cells holding conflicting data perturb the bitline around $\sim VDD/2$, and the sense amplifier samples a random value.

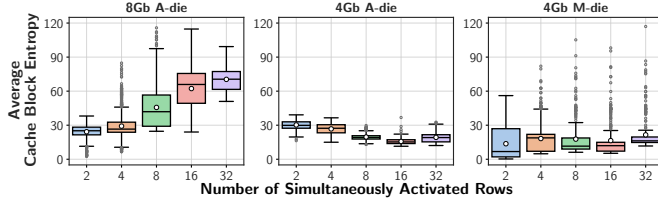

Figure 2: Average 512-bit cache-block entropy for varying numbers of simultaneously activated rows, across DRAM chip densities and die revisions.

ACT→PRE→ACT command sequence with reduced DRAM timings to activate the high-entropy SAR group, thereby generating random bits in the sense amplifiers of four DRAM banks concurrently, 4) reading from the four banks until 256 bits of Shannon entropy is obtained, and 5) post-processing the extracted bitstream using the SHA-256 cryptographic hash function [270] to eliminate bias & correlation.

Real DRAM Chip Characterization. We conduct a rigorous experimental characterization of 96 COTS DDR4 chips using an FPGA-based DRAM testing infrastructure [271, 272] (built on top of SoftMC [273, 274]). We sweep the number of simultaneously activated rows, the data pattern, temperature, and spatial location, showing that SiMRA can generate random values with all the tested numbers of simultaneously activated rows. We highlight three new empirical observations from this experiment. First, entropy tends to increase with the number of simultaneously activated rows: across all tested chips, SiMRA generates 22.87, 25.17, 29.47, 34.54, and 40.41 average cache-block entropy with 2-, 4-, 8-, 16-, and 32-row activation, respectively (Fig. 2). Second, entropy also depends strongly on the data pattern, and is highest when the data pattern has an equal number of logic-1s and logic-0s. We hypothesize this is because during charge sharing, logic-1 cells attempt to raise the bitline voltage while logic-0 cells attempt to lower it; thus, the bitline voltage converges to the reference voltage, the differential voltage falls well below the sense amplifier’s reliable sensing margin, and the sense amplifier non-deterministically settles to logic-1 or logic-0. Third, temperature affects the SiMRA’s entropy. For example, for 32-row activation, as the temperature increases from 50 °C to 90 °C, average cache-block entropy decreases by 1.53×.

Quality and Throughput. True random numbers generated by SiMRA-TRNG pass *all* NIST STS tests [275], and SiMRA-TRNG reliably produces high-quality true random bit-

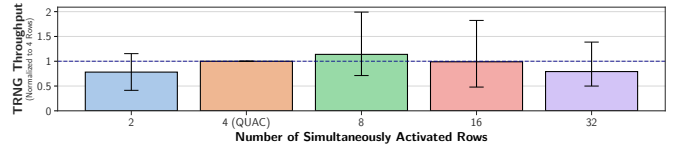

Figure 3: Throughput of generating true random numbers using SiMRA for varying numbers of simultaneously activated rows, normalized to the state-of-the-art DRAM-based TRNG (QUAC-TRNG, 4-row activation) [71].

streams for all tested numbers of simultaneously activated rows. SiMRA-TRNG designs based on 2-, 8-, 16-, and 32-row activation outperform the state-of-the-art DRAM-based TRNG (QUAC-TRNG, which uses 4-row activation), achieving up to 1.15×, 1.99×, 1.82×, and 1.39× higher throughput, respectively (Fig. 3). The 2-, 4-, 8-, 16-, and 32-row activation-based designs provide average throughputs of 9.90, 13.81, 16.05, 13.94, and 10.81 Gb/s, respectively. There is a tradeoff between TRNG latency and the entropy produced by SiMRA: while simultaneously activating more rows tends to generate more entropy, it also increases the TRNG latency, so the higher entropy of 32-row activation does not lead to higher throughput, because the latency of initializing the simultaneously activated rows is doubled compared to 16-row activation.

SiMRA-TRNG outperforms the state-of-the-art DRAM-based TRNG in throughput and offers a promising approach to generating true random numbers with high throughput, directly inside real, unmodified COTS DRAM chips.

2.3. In-DRAM Physical Unclonable Functions

A physically unclonable function (PUF) maps a set of input parameters to unique, device-specific signatures that can be generated repeatably and reliably. The resulting signature reflects a device’s inherent, random physical variations introduced during manufacturing, which makes it practically impossible to predict or replicate without access to the device itself [276, 277]. These characteristics enable PUFs to be frequently used in security applications, such as low-cost authentication against security attacks and prevention of integrated-circuit counterfeiting, typically through a challenge-response protocol in which a trusted server challenges a device and verifies its PUF response [197, 202]. A runtime-accessible PUF, i.e., one that an application can evaluate on demand during online operation, must additionally be evaluated with low latency and cause low system interference.

DRAM-based PUFs are attractive for two key reasons. First, DRAM is already widely used in modern systems, ranging from embedded to server. Second, DRAM’s large address space provides a greater challenge-response space than smaller components such as SRAM. Prior DRAM PUF proposals exploit variations in DRAM start-up values, DRAM access latencies, and DRAM cell retention failures, and DRAM read disturbance to generate PUF responses [196–198, 202–212, 278]. Unfortunately, these proposals are unsuitable as runtime-accessible PUFs: start-up-value PUFs require a DRAM power cycle for every authentication, write-latency PUFs require additional circuitry in the DRAM chip, and retention-failure PUFs are too slow, taking on the order of minutes to evaluate at typical

operating temperatures.

Recent works [73, 82, 217, 218] enable fast, reliable, runtime-accessible PUFs even in modified and commodity off-the-shelf DRAM chips by exploiting the error patterns induced by violating DRAM access timing parameters. The DRAM Latency PUF [73] is a fast, reliable, runtime-accessible DRAM-based PUF whose key idea is to reduce the DRAM read access latency below the reliable manufacturer-recommended specifications. Doing so results in error patterns that reflect the compound effects of manufacturing variations in various DRAM structures (e.g., capacitors, transistors, sense amplifiers): some DRAM cells fail always after repeated accesses with violated timing parameters and some others never fail at all, and a combination of such consistently failing or never failing cells generates a unique identifier for the device. An experimental characterization of 223 LPDDR4 chips from all three major manufacturers shows that these error patterns are quickly generated (at 88.2 ms) irrespective of operating temperature, without any modification to the DRAM chip. Another line of work generates signatures by controlling DRAM’s internal circuitry and sensing cells at fractional voltage levels. CODIC [82] is a low-cost DRAM substrate that enables fine-grained control over four previously fixed internal DRAM signals, including those that trigger the sense amplifiers; by controlling when the sense amplifiers fire, CODIC senses cells at fractional voltage levels, and its CODIC-sig command generates digital signatures that depend on process variation. A CODIC-based PUF that uses these signatures provides $1.8\times$ higher throughput than the best prior DRAM-based PUF at that time, with similar resilience to temperature changes and more repeatable responses. The Frac-based PUF [217], the prior state-of-the-art DRAM-based PUF, builds on top of CODIC to leverage fractional voltage levels on commodity off-the-shelf chips without any modification: it initializes a target row with all ones and repeatedly applies the Frac operation (back-to-back ACT→PRE command pairs with reduced timing) to drive the DRAM cells toward $V_{DD}/2$, after which a subsequent activation resolves each cell to logic-0 or logic-1 according to the manufacturing process variation. The current state-of-the-art DRAM-based PUF, SiMRA-PUF [218], leverages simultaneous multiple-row activation to generate device-specific signatures and outperforms the Frac-based PUF in evaluation latency, which we describe in detail next.

2.4. State-of-the-Art DRAM-based PUF: SiMRA-PUF

Key Idea. The *key idea* of SiMRA-PUF is to generate device-specific signatures by exploiting the charge-sharing process that arises from simultaneously activating multiple DRAM rows holding opposing data patterns. An ACT→PRE→ACT (APA) command sequence with reduced timings simultaneously activates multiple rows initialized with a balanced data pattern, enabling charge sharing between the activated cells and the bitlines. Because the cells hold opposing values, the resulting bitline perturbation does not strongly deviate from the reference voltage. However, due to process- and design-induced variations, each bitline settles at a voltage near, but

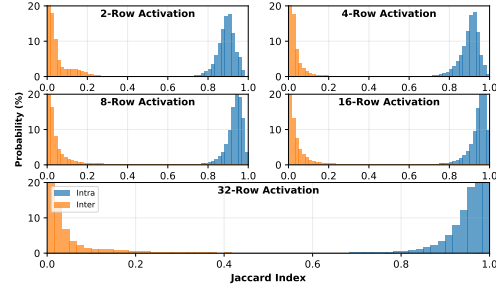

Figure 4: Inter- (orange) and intra-Jaccard (blue) indices obtained for 2/4/8/16/32-row activation-based SiMRA-PUF.

slightly different from, the reference voltage. The sense amplifiers then resolve the bitlines to logic-0 or logic-1: for some bitlines, the perturbation falls below the reliable sensing margin and the sense amplifier resolves the bitline randomly across SiMRA trials, whereas for others the perturbation exceeds the margin and the sense amplifier resolves the bitline to a single, stable value across trials. These stable, device-specific bits form the signature.

Challenge and Response. SiMRA-PUF defines each challenge as a (bank, subarray) pair. To generate a response, it initializes a simultaneously-activated-row (SAR) group with a balanced data pattern, issues an APA command sequence, and reads the sense amplifier outputs as the signature; the PUF response is the signature read from the selected SAR group.

Real DRAM Chip Characterization. SiMRA-PUF is characterized on 112 COTS DDR4 chips (from 10 modules), using the intra-Jaccard index (response stability, higher is better) and the inter-Jaccard index (response uniqueness, lower is better). SiMRA-PUF provides average inter-Jaccard indices of 3.98%, 2.37%, 3.44%, 2.92%, and 3.24%, and average intra-Jaccard indices of 89.02%, 89.81%, 93.03%, 94.06%, and 94.86%, for 2-, 4-, 8-, 16-, and 32-row activation, respectively (Fig. 4). SiMRA-PUF thus produces unique and repeatable responses across all tested activation counts.

Comparison with the Prior State-of-the-Art. SiMRA-PUF provides intra-Jaccard indices similar to the Frac-based PUF [217] (95.62%), with the gap narrowing as the number of simultaneously activated rows increases. Most importantly, 2-row activation-based SiMRA-PUF has 5.75% lower evaluation latency than the Frac-based PUF, although evaluation latency grows with the number of activated rows. For example, 32-row activation reaches $3.84\times$ the latency of Frac-based PUF [217].

These results show that SiMRA generates device-specific signatures suitable for high-quality, reliable PUF responses, and that 2-row SiMRA-PUF achieves lower evaluation latency than the prior state-of-the-art DRAM-based PUF, directly on real, unmodified COTS DRAM chips.

3. Security Challenges in Processing-in-DRAM

As a new processing paradigm, Processing-in-DRAM introduces new security considerations related to its integration in real-world computing systems. We focus on two of them, one affecting reliability and one affecting confidentiality.

First, modern DRAM is subject to read disturbance, a worsening safety, security, and reliability phenomenon in which

repeatedly accessing one DRAM row induces bitflips in physically nearby, unaccessed rows [39, 219, 221–223, 271, 279–304]. RowHammer [221] and RowPress [222] are two prominent examples, where a row (victim row) experiences bitflips when a nearby row (aggressor row) is repeatedly activated (hammered) or kept open for a long period (pressed). Since PuD operations rely on multiple-row activation, where multiple DRAM rows are activated simultaneously or in quick succession, they can exacerbate DRAM read disturbance, as PuDHammer [219] shows.

Second, the adoption of processing-in-memory provides applications with a new, direct, and fast way to access main memory, which malicious applications can exploit. Naively providing such access may lead to unforeseen information leakage and other confidentiality and integrity issues. In particular, it opens high throughput timing attack vectors that are hard to mitigate without significant performance overhead, as IMPACT [220] shows.

3.1. Read Disturbance Effects of Processing-using-DRAM: PuDHammer

PuDHammer [219] presents the first experimental characterization of the read disturbance effects of Processing-using-DRAM (PuD) operations, on 316 real DDR4 chips from four major manufacturers.

Key Idea. PuD operations leverage an analog DRAM operation called multiple-row activation, where multiple DRAM rows are activated simultaneously or in quick succession. PuDHammer characterizes the read-disturbance effects of its two types: consecutive multiple-row activation (CoMRA), used for in-DRAM data copy & initialization, and simultaneous multiple-row activation (SiMRA), used for in-DRAM bitwise operations. To hammer with CoMRA, PuDHammer repeatedly performs consecutive activation of a source and a destination row; to hammer with SiMRA, it issues an ACT→PRE→ACT command sequence with reduced DRAM timings to simultaneously activate multiple rows. In both cases, the activated rows become aggressor rows and their neighboring rows become victim rows; when two activated rows sandwich a victim row, this forms a double-sided attack.

Takeaway from Real DRAM Chip Characterization. Both CoMRA and SiMRA greatly increase a DRAM chip’s read-disturbance vulnerability, decreasing the minimum hammer count required to induce the first bitflip (HC_{first}) in all tested DRAM chips from four manufacturers. The effect is strongest for SiMRA: across all tested chips, the lowest HC_{first} observed with double-sided SiMRA is up to $158.58\times$ lower than with double-sided RowHammer (Fig. 5), while the lowest HC_{first} with double-sided CoMRA is up to $13.98\times$ lower than with double-sided RowHammer. PuD operations thus make a DRAM chip far more vulnerable to read disturbance than conventional read disturbance access patterns (e.g., RowHammer).

Mitigation. PuDHammer adapts and evaluates the industry’s state-of-the-art RowHammer mitigation, Per-Row Activation Counting (PRAC) [305], and finds that the adapted PRAC solution incurs an average system performance overhead of 48.26%

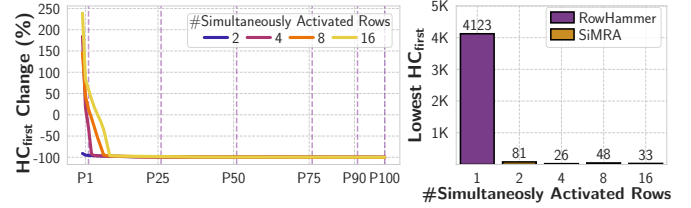

Figure 5: Distribution of the change in HC_{first} change with double-sided SiMRA compared to double-sided RowHammer (left) and the lowest HC_{first} observed with double-sided SiMRA and RowHammer (right).

across 60 five-core multiprogrammed workloads, showing that extending existing RowHammer defenses to PuD is costly and that read-disturbance-resilient PuD systems call for new solutions.

3.2. Timing Attacks in Processing-in-DRAM: IMPACT

IMPACT [220] is a set of high throughput main memory-based timing attacks that leverage characteristics of processing-in-memory (PiM) architectures to establish covert and side channels.

Key Idea. The adoption of PiM provides userspace applications with fast and reliable direct access to main memory that bypasses the cache hierarchy. IMPACT observes and exploits the shared DRAM row buffer: because a row-buffer conflict takes measurably longer than a row-buffer hit, an application can infer whether a row was recently accessed by timing its accesses. IMPACT achieves high throughput by (i) eliminating the expensive cache-bypassing steps required by processor-centric timing attacks and (ii) leveraging the intrinsic parallelism of PiM operations.

Attacks. IMPACT is demonstrated with three case studies. First, IMPACT-PnM is a covert channel that exploits PiM-enabled instructions [28], a PnM mechanism that executes simple operations in compute units near DRAM: the sender encodes a message as row-buffer conflicts at selected addresses, and the receiver detects them by timing how long a PiM-enabled instruction takes to operate on those rows. Second, IMPACT-PuM is a covert channel that instead exploits RowClone [50], a PuM operation that performs bulk in-DRAM row copy: the sender transmits bits by copying rows in different DRAM banks in parallel, and the receiver decodes them by issuing its own row-copy operations and measuring their latency. Third, IMPACT’s side-channel attack uses PiM-enabled instructions to leak the private information of a concurrently-running application by observing its memory access patterns. IMPACT side channel attack is demonstrated on a genomic privacy proof-of-concept attack, where the attacker leaks private characteristics of a user’s query genome by observing the memory access patterns of a read mapping application.

Example: the IMPACT-PuM Covert Channel. We use IMPACT-PuM to illustrate IMPACT’s end-to-end flow (Fig. 6). Before the attack, the sender and receiver co-locate their data in the same set of DRAM banks. The sender then transmits the message in M -bit batches: it maps each bit of a batch to a separate DRAM bank and builds a mask, so that a single

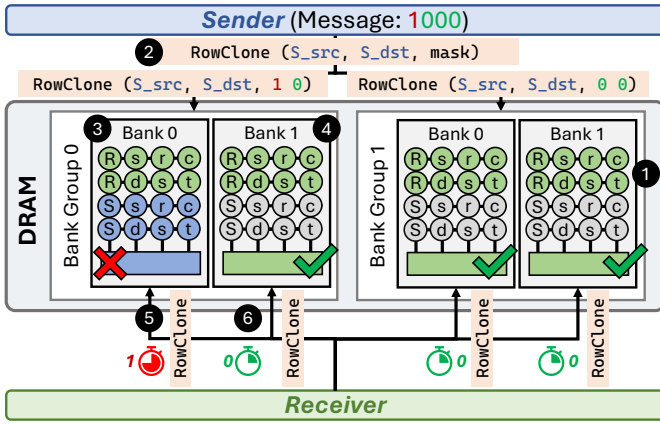

Figure 6: PuM covert-channel attack flow (IMPACT-PuM).

RowClone operation transmits an entire M -bit batch in parallel (where M is the number of banks). To send a 1, the sender triggers RowClone in the corresponding bank, activating a different row from the receiver’s and causing interference; to send a 0, it issues no RowClone’s and does not interfere. The receiver decodes the batch by issuing one RowClone operation per bank and measuring its latency: a high latency indicates a row-buffer conflict (logic-1), and a low latency indicates a row-buffer hit (logic-0).

Result. IMPACT-PuM achieves a communication throughput of 14.8 Mb/s, $6.5\times$ higher than the state-of-the-art main memory-based covert channel, and the side-channel attack on genomic read mapping leaks the private characteristics of a user’s query genome at 7.6 Mb/s with 96% accuracy.

Mitigation. IMPACT evaluates four defense mechanisms that attempt to eliminate the timing channel, but finds that mitigating IMPACT incurs high performance overheads, concluding that more research is needed to find low-overhead solutions.

4. Conclusion and Outlook

We examined the security benefits and challenges of memory-centric computing, specifically Processing-in-DRAM (PiD). By eliminating data movement between memory and processor, the PiD paradigm takes a large step towards getting rid of one of the most attacker-exposed types of data movement within a computing node, i.e., data movement over the main memory bus. Enabling the secure and private execution of computations in PiD systems can therefore potentially enable fundamentally more secure computing systems. This requires providing support for such secure computation. For example, our afore-described SiMRA-TRNG and SiMRA-PUF are two notable examples of novel in-DRAM security primitives that take advantage of PiD.

As in existing systems, robustness and information security are important in PiD systems, where DRAM rows can be frequently activated and deactivated and/or can be accessed directly via a fast path. We described two such works that can amplify the current robustness and security issues in computing systems: PuDHammer, which greatly exacerbates DRAM read disturbance, and IMPACT, which exploits direct, fast memory access to amplify high throughput timing attacks.

We firmly believe that it is time to architect principled computing systems where DRAM (and in general, memory; see [1, 2, 5] for a broad discussion) is designed, used, and programmed not as an inactive storage substrate, but instead as a *combined computation, storage, and security substrate* where computational capability, storage density, and security are key goals. Although many challenges remain to enable widespread adoption of Processing-in-DRAM (and memory-centric systems in general), we believe the mindset and infrastructure shift necessary to enable such a secure computation-storage paradigm remains to be the largest challenge. Overcoming this mindset and infrastructure shift can unleash a fundamentally more secure, energy-efficient, and high-performance way to design, use, and program computing systems.

We therefore believe the future of memory-centric systems is very bright and promising, yet there needs to be many exciting challenges to be solved across the computing stack to facilitate widespread and easy adoption.

Acknowledgments

We thank the SAFARI Research Group members for providing a stimulating intellectual and scientific environment. We acknowledge the generous gifts from our industrial partners, including Google, Huawei, Intel, and Microsoft. This work, along with our broader work in Processing-in-Memory and memory systems [1, 2, 5, 8, 17, 35, 38, 39, 221, 284–286, 306–321], is supported in part by the Semiconductor Research Corporation (SRC), the ETH Future Computing Laboratory (EFCL), ACCESS – AI Chip Center for Emerging Smart Systems, a Google Security and Privacy Research Award, and the Microsoft Swiss Joint Research Center.

References

- [1] Onur Mutlu, Saugata Ghose, Juan Gómez-Luna, and Rachata Ausavarungnirun. Processing Data Where It Makes Sense: Enabling In-Memory Computation. *MICPRO*, 2019.
- [2] Onur Mutlu, Saugata Ghose, Juan Gómez-Luna, and Rachata Ausavarungnirun. A Modern Primer on Processing in Memory. arXiv, 2025.
- [3] Amirali Boroumand, Saugata Ghose, Youngsok Kim, Rachata Ausavarungnirun, Eric Shiu, Rahul Thakur, Daehyun Kim, Aki Kuusela, Allan Knies, Parthasarathy Ranganathan, and Onur Mutlu. Google Workloads for Consumer Devices: Mitigating Data Movement Bottlenecks. In *ASPLOS*, 2018.
- [4] Amirali Boroumand, Saugata Ghose, Berkin Akin, Ravi Narayanaswami, Geraldo F Oliveira, Xiaoyu Ma, Eric Shiu, and Onur Mutlu. Google Neural Network Models for Edge Devices: Analyzing and Mitigating Machine Learning Inference Bottlenecks. In *PACT*, 2021.
- [5] Saugata Ghose, Amirali Boroumand, Jeremie S Kim, Juan Gómez-Luna, and Onur Mutlu. Processing-in-Memory: A Workload-Driven Perspective. *IBM JRD*, 2019.
- [6] Tom B. Brown, Benjamin Mann, Nick Ryder, Melanie Subbiah, Jared Kaplan, Prafulla Dhariwal, Arvind Neelakantan, Pranav Shyam, Girish Sastry, Amanda Askell, Sandhini Agarwal, Ariel Herbert-Voss, Gretchen Krueger, Tom Henighan, Rewon Child, Aditya Ramesh, Daniel M. Ziegler, Jeffrey Wu, Clemens Winter, Christopher Hesse, Mark Chen, Eric Sigler, Mateusz Litwin, Scott Gray, Benjamin Chess, Jack Clark, Christopher Berner, Sam McCandlish, Alec Radford, Ilya Sutskever, and Dario Amodei. Language Models are Few-Shot Learners. In *NIPS*, 2020.
- [7] Jacob Devlin, Ming-Wei Chang, Kenton Lee, and Kristina Toutanova. BERT: Pre-training of Deep Bidirectional Transformers for Language Understanding. In *NAACL*, 2019.
- [8] Geraldo F Oliveira, Juan Gómez-Luna, Saugata Ghose, Amirali Boroumand, and Onur Mutlu. Accelerating Neural Network Inference with Processing-in-DRAM: From the Edge to the Cloud. *IEEE Micro*, 2022.
- [9] Guseul Heo, Sangyeop Lee, Jaehong Cho, Hyunmin Choi, Sanghyeon Lee, Hyungkyu Ham, Gwangsun Kim, Divya Mahajan, and Jongse Park. Neupims: Npu-pim Heterogeneous Acceleration for Batched LLM Inferencing. In *ASPLOS*, 2024.
- [10] Minxuan Zhou, Weihong Xu, Jaeyoung Kang, and Tajana Rosing. TransPIM: A Memory-based Acceleration via Software-Hardware Co-Design for Transformer. In *HPCA*, 2022.

- [11] Jaehyun Park, Jaewan Choi, Kwanhee Kyung, Michael Jaemin Kim, Yongsuk Kwon, Nam Sung Kim, and Jung Ho Ahn. AttAcc! Unleashing the Power of PIM for Batched Transformer-based Generative Model Inference. In *ASPLOS*, 2024.
- [12] Minseok Seo, Xuan Truong Nguyen, Seok Joong Hwang, Yongkee Kwon, Guhyun Kim, Chanwook Park, Ilkon Kim, Jaehun Park, Jeongbin Kim, Woojae Shin, et al. IANUS: Integrated Accelerator based on NPU-PIM Unified Memory System. In *ASPLOS*, 2024.
- [13] Steve Rhyner, Haocong Luo, Juan Gomez-Luna, Mohammad Sadrosadati, Jiawei Jiang, Ataberk Olgun, Harshita Gupta, Ce Zhang, and Onur Mutlu. PIM-Opt: Demystifying Distributed Optimization Algorithms on a Real-World Processing-In-Memory System. In *PACT*, 2024.
- [14] Sungmin Yun, Kwanhee Kyung, Juhwan Cho, Jaewan Choi, Jongmin Kim, Byeongho Kim, Sukhan Lee, Kyomin Sohn, and Jung Ho Ahn. Duplex: A Device for Large Language Models with Mixture of Experts, Grouped Query Attention, and Continuous Batching. In *MICRO*, 2024.
- [15] Hongsun Jang, Jaeyong Song, Jaewon Jung, Jaeyoung Park, Youngsok Kim, and Jinho Lee. Smart-Infinity: Fast Large Language Model Training using Near-Storage Processing on a Real System. In *HPCA*, 2024.
- [16] Mohammed Alser, Zülal Bingöl, Damla Senol Cali, Jeremie Kim, Saugata Ghose, Can Alkan, and Onur Mutlu. Accelerating Genome Analysis: A Primer on an Ongoing Journey. *IEEE Micro*, 2020.
- [17] Gagandeep Singh, Mohammed Alser, Damla Senol Cali, Dionysios Diamantopoulos, Juan Gómez-Luna, Henk Corporaal, and Onur Mutlu. FPGA-Based Near-Memory Acceleration of Modern Data-Intensive Applications. *IEEE Micro*, 2021.
- [18] Mohammed Alser, Joel Lindegger, Can Firtina, Nour Almadhoun, Haiyu Mao, Gagandeep Singh, Juan Gomez-Luna, and Onur Mutlu. From Molecules to Genomic Variations: Accelerating Genome Analysis via Intelligent Algorithms and Architectures. *CSBJ*, 2022.
- [19] Jeremie S Kim, Damla Senol Cali, Hongyi Xin, Donghyuk Lee, Saugata Ghose, Mohammed Alser, Hasan Hassan, Oguz Ergin, Can Alkan, and Onur Mutlu. GRIM-Filter: Fast Seed Location Filtering in DNA Read Mapping using Processing-in-Memory Technologies. In *APBC*, 2018.
- [20] Nika Mansouri Ghiasi, Jisung Park, Harun Mustafa, Jeremie Kim, Ataberk Olgun, Arvid Gollwitzer, Damla Senol Cali, Can Firtina, Haiyu Mao, Nour Almadhoun Alser, et al. GenStore: A High-Performance and Energy-Efficient In-Storage Computing System for Genome Sequence Analysis. In *ASPLOS*, 2022.
- [21] Nika Mansouri Ghiasi, Mohammad Sadrosadati, Harun Mustafa, Arvid Gollwitzer, Can Firtina, Julien Eudine, Haiyu Mao, Joël Lindegger, Meryem Banu Cavlak, Mohammed Alser, et al. MegIS: High-Performance, Energy-Efficient, and Low-Cost Metagenomic Analysis with In-Storage Processing. In *ISCA*, 2024.
- [22] Damla Senol Cali, Gurpreet S Kalsi, Zülal Bingöl, Can Firtina, Lavanya Subramanian, Jeremie S Kim, Rachata Ausavarungnirun, Mohammed Alser, Juan Gomez-Luna, Amirali Boroumand, et al. GenASM: A High-Performance, Low-Power Approximate String Matching Acceleration Framework for Genome Sequence Analysis. In *MICRO*, 2020.
- [23] Damla Senol Cali, Konstantinos Kanellopoulos, Joel Lindegger, Zülal Bingöl, Gurpreet S Kalsi, Ziyi Zuo, Can Firtina, Meryem Banu Cavlak, Jeremie Kim, Nika Mansouri Ghiasi, et al. SeGraM: A Universal Hardware Accelerator for Genomic Sequence-to-Graph and Sequence-to-Sequence Mapping. In *ISCA*, 2022.
- [24] Damla Senol Cali, Jeremie S Kim, Saugata Ghose, Can Alkan, and Onur Mutlu. Nanopore Sequencing Technology and Tools for Genome Assembly: Computational Analysis of the Current State, Bottlenecks and Future Directions. *Briefings in Bioinformatics*, 2018.
- [25] Yintao He, Haiyu Mao, Christina Giannoula, Mohammad Sadrosadati, Juan Gómez-Luna, Huawei Li, Xiaowei Li, Ying Wang, and Onur Mutlu. PAPI: Exploiting Dynamic Parallelism in Large Language Model Decoding with a Processing-In-Memory-Enabled Computing System. *ASPLOS*, 2025.
- [26] Yufeng Gu, Alireza Khadem, Sumanth Umesh, Ning Liang, Xavier Servot, Onur Mutlu, Ravi Iyer, and Reetuparna Das. PIM Is All You Need: A CXL-Enabled GPU-Free System for Large Language Model Inference. *ASPLOS*, 2025.
- [27] Junwhan Ahn, Sungpack Hong, Sungjoo Yoo, Onur Mutlu, and Kiyoung Choi. A Scalable Processing-in-Memory Accelerator for Parallel Graph Processing. In *ISCA*, 2015.
- [28] Junwhan Ahn, Sungjoo Yoo, Onur Mutlu, and Kiyoung Choi. PIM-Enabled Instructions: A Low-Overhead, Locality-Aware Processing-in-Memory Architecture. In *ISCA*, 2015.
- [29] Lifeng Nai, Ramyad Hadidi, Jaewoong Sim, Hyojong Kim, Pranith Kumar, and Hyesoon Kim. GraphPIM: Enabling Instruction-Level PIM Offloading in Graph Computing Frameworks. In *HPCA*, 2017.
- [30] Maciej Besta, Raghavendra Kanakagiri, Grzegorz Kwasniewski, Rachata Ausavarungnirun, Jakob Beránek, Konstantinos Kanellopoulos, Kacper Janda, Zur Vonarburg-Shmaria, Lukas Gianinazzi, Ioana Stefan, et al. SISA: Set-Centric Instruction Set Architecture for Graph Mining on Processing-in-Memory Systems. In *MICRO*, 2021.
- [31] S. Salihoglu and J. Widom. GPS: A Graph Processing System. In *SSDBM*, 2013.
- [32] Yuanyuan Tian, Andrey Balmin, Severin Andreas Corsten, Shirish Tatikonda, and John McPherson. From “Think Like a Vertex to “Think Like a Graph”. *VLDB*, 2013.
- [33] Yucheng Low, Danny Bickson, Joseph Gonzalez, Carlos Guestrin, Aapo Kyrola, and Joseph M Hellerstein. Distributed GraphLab: A Framework for Machine Learning and Data Mining in the Cloud. *VLDB*, 2012.
- [34] Vivek Seshadri, Donghyuk Lee, Thomas Mullins, Hasan Hassan, Amirali Boroumand, Jeremie Kim, Michael A Kozuch, Onur Mutlu, Phillip B Gibbons, and Todd C Mowry. Ambit: In-Memory Accelerator for Bulk Bitwise Operations Using Commodity DRAM Technology. In *MICRO*, 2017.
- [35] Geraldo F. de Oliveira, Juan Gomez-Luna, Lois Orosa, Saugata Ghose, Nandita Vijaykumar, Ivan Fernandez, Mohammad Sadrosadati, and Onur Mutlu. DAMOV: A New Methodology and Benchmark Suite for Evaluating Data Movement Bottlenecks. *IEEE Access*, 2021.
- [36] Juan Gómez-Luna, Izzat El Hajj, Ivan Fernandez, Christina Giannoula, Geraldo F Oliveira, and Onur Mutlu. Benchmarking a New Paradigm: Experimental Analysis and Characterization of a Real Processing-in-Memory System. *IEEE Access*, 2022.
- [37] Amirali Boroumand, Saugata Ghose, Geraldo F Oliveira, and Onur Mutlu. Polynesia: Enabling High-Performance and Energy-Efficient Hybrid Transactional/Analytical Databases with Hardware/Software Co-Design. In *ICDE*, 2022.
- [38] Onur Mutlu, Ataberk Olgun, Geraldo F Oliveira, and Ismail E Yuksel. Memory-Centric Computing: Recent Advances in Processing-in-DRAM. In *IEDM*, 2024.
- [39] Onur Mutlu, Ataberk Olgun, and Ismail Emir Yuksel. Memory-Centric Computing: Solving Computing’s Memory Problem. In *IMW*, 2025.
- [40] HMC Consortium. Hybrid Memory Cube Specification Rev. 2.0. 2013.
- [41] JEDEC. JESD235 High Bandwidth Memory (HBM) DRAM, 2013.
- [42] Donghyuk Lee, Saugata Ghose, Gennady Pekhimenko, Samira Khan, and Onur Mutlu. Simultaneous Multi-Layer Access: Improving 3D-Stacked Memory Bandwidth at Low Cost. *TACO*, 2016.
- [43] Kwiwook Kim and Myeong-jae Park. Present and Future, Challenges of High Bandwidth Memory (HBM). In *IMW*, 2024.
- [44] Kevin Hsieh, Eiman Ebrahimi, Gwangsun Kim, Niladrish Chatterjee, Mike O’Connor, Nandita Vijaykumar, Onur Mutlu, and Stephen W Keckler. Transparent Offloading and Mapping (TOM): Enabling Programmer-Transparent Near-Data Processing in GPU Systems. In *ISCA*, 2016.
- [45] Amirali Boroumand, Saugata Ghose, Minesh Patel, Hasan Hassan, Brandon Lucia, Kevin Hsieh, Krishna T. Malladi, Hongzhong Zheng, and Onur Mutlu. CoNDA: Enabling Efficient Near-Data Accelerator Communication by Optimizing Data Movement. *ISCA*, 2019.
- [46] Ping Chi, Shuangchen Li, Cong Xu, Tao Zhang, Jishen Zhao, Yongpan Liu, Yu Wang, and Yuan Xie. PRIME: A Novel Processing-in-Memory Architecture for Neural Network Computation in ReRAM-Based Main Memory. In *ISCA*, 2016.
- [47] Ali Shafiee, Anirban Nag, Naveen Muralimanohar, Rajeev Balasubramonian, John Paul Strachan, Miao Hu, R. Stanley Williams, and Vivek Srikumar. ISAAC: A Convolutional Neural Network Accelerator with In-Situ Analog Arithmetic in Crossbars. In *ISCA*, 2016.
- [48] Vivek Seshadri and Onur Mutlu. In-DRAM Bulk Bitwise Execution Engine. *arXiv*, 2019.
- [49] Shuangchen Li, Dimin Niu, Krishna T Malladi, Hongzhong Zheng, Bob Brennan, and Yuan Xie. DRISA: A DRAM-Based Reconfigurable In-Situ Accelerator. In *MICRO*, 2017.
- [50] Vivek Seshadri, Yoongu Kim, Chris Fallin, Donghyuk Lee, Rachata Ausavarungnirun, Gennady Pekhimenko, Yixin Luo, Onur Mutlu, Phillip B Gibbons, Michael A Kozuch, and Todd Mowry. RowClone: Fast and Energy-Efficient In-DRAM Bulk Data Copy and Initialization. In *MICRO*, 2013.
- [51] Vivek Seshadri and Onur Mutlu. The Processing Using Memory Paradigm: In-DRAM Bulk Copy, Initialization, Bitwise AND and OR. arXiv:1610.09603 [cs.AR], 2016.
- [52] Quan Deng, Lei Jiang, Youtao Zhang, Minxuan Zhang, and Jun Yang. DrAcc: A DRAM Based Accelerator for Accurate CNN Inference. In *DAC*, 2018.
- [53] Xin Xin, Youtao Zhang, and Jun Yang. ELP2IM: Efficient and Low Power Bitwise Operation Processing in DRAM. In *HPCA*, 2020.
- [54] Linghao Song, Youwei Zhuo, Xuehai Qian, Hai Li, and Yiran Chen. GraphR: Accelerating Graph Processing Using ReRAM. In *HPCA*, 2018.
- [55] Linghao Song, Xuehai Qian, Hai Li, and Yiran Chen. PipeLayer: A Pipelined ReRAM-Based Accelerator for Deep Learning. In *HPCA*, 2017.
- [56] Fei Gao, Georgios Tziatzoulis, and David Wentzlaff. ComputeDRAM: In-Memory Compute Using Off-the-Shelf DRAMs. In *MICRO*, 2019.
- [57] Charles Eckert, Xiaowei Wang, Jingcheng Wang, Arun Subramanian, Ravi Iyer, Dennis Sylvester, David Blaauw, and Reetuparna Das. Neural Cache: Bit-Serial In-Cache Acceleration of Deep Neural Networks. In *ISCA*, 2018.
- [58] Shaizeen Aga, Supreet Jeloka, Arun Subramanian, Satish Narayanasamy, David Blaauw, and Reetuparna Das. Compute Caches. In *HPCA*, 2017.
- [59] Daichi Fujiki, Scott Mahlke, and Reetuparna Das. Duality Cache for Data Parallel Acceleration. In *ISCA*, 2019.
- [60] Vivek Seshadri, Donghyuk Lee, Thomas Mullins, Hasan Hassan, Amirali Boroumand, Jeremie Kim, Michael A Kozuch, Onur Mutlu, Phillip B Gibbons, and Todd C Mowry. Buddy-RAM: Improving the Performance and Efficiency of Bulk Bitwise Operations Using DRAM. arXiv, 2016.
- [61] Vivek Seshadri and Onur Mutlu. Simple Operations in Memory to Reduce Data Movement. In *Advances in Computers, Volume 106*, 2017.
- [62] Vivek Seshadri, Yoongu Kim, Chris Fallin, Donghyuk Lee, Rachata Ausavarungnirun, Gennady Pekhimenko, Yixin Luo, Onur Mutlu, Phillip B. Gibbons, Michael A. Kozuch, and Todd C. Mowry. RowClone: Accelerating Data Movement and Initialization Using DRAM. arXiv, 2018.
- [63] Vivek Seshadri, Kevin Hsieh, Amirali Boroumand, Donghyuk Lee, Michael A. Kozuch, Onur Mutlu, Phillip B. Gibbons, and Todd C. Mowry. Fast Bulk Bitwise AND and OR in DRAM. 2015.
- [64] Shuangchen Li, Cong Xu, Qiaosha Zou, Jishen Zhao, Yu Lu, and Yuan Xie. Pinatubo: A Processing-in-Memory Architecture for Bulk Bitwise Operations in Emerging Non-Volatile Memories. In *DAC*, 2016.
- [65] João Dinis Ferreira, Gabriel Falcao, Juan Gómez-Luna, Mohammed Alser, Lois Orosa, Mohammad Sadrosadati, Jeremie S. Kim, Geraldo F. Oliveira, Taha Shahroodi, Anant Nori, and Onur Mutlu. pLUTO: In-DRAM Lookup Tables to Enable Massively Parallel General-Purpose Computation. In *MICRO*, 2022.

- [66] Mohsen Imani, Saransh Gupta, Yeseong Kim, and Tajana Rosing. FloatPIM: In-Memory Acceleration of Deep Neural Network Training with High Precision. In *ISCA*, 2019.
- [67] Zhezhi He, Li Yang, Shaahin Angizi, Adnan Siraj Rakin, and Deliang Fan. Sparse BD-Net: A Multiplication-Less DNN with Sparse Binarized Depth-Wise Separable Convolution. *JETC*, 16(2):1–24, 2020.
- [68] Jisung Park, Roknoddin Azizi, Geraldo F. Oliveira, Mohammad Sadrosadati, Rakesh Nadig, David Novo, Juan Gómez-Luna, Myungsuk Kim, and Onur Mutlu. Flash-Cosmos: In-Flash Bulk Bitwise Operations Using Inherent Computation Capability of NAND Flash Memory. In *MICRO*, 2022.
- [69] Minh SQ Truong, Liting Shen, Alexander Glass, Alison Hoffmann, L Richard Carley, James A Bain, and Saugata Ghose. Adapting the RACER Architecture to Integrate Improved In-ReRAM Logic Primitives. *JETCAS*, 2022.
- [70] Minh SQ Truong, Eric Chen, Deanyone Su, Liting Shen, Alexander Glass, L Richard Carley, James A Bain, and Saugata Ghose. RACER: Bit-Pipelined Processing Using Resistive Memory. In *MICRO*, 2021.
- [71] Ataberk Olgun, Minesh Patel, A Giray Yağlıkcı, Haocong Luo, Jeremie S Kim, Nisa Bostanci, Nandita Vijaykumar, Oğuz Ergin, and Onur Mutlu. QUAC-TRNG: High-Throughput True Random Number Generation Using Quadruple Row Activation in Commodity DRAM Chips. In *ISCA*, 2021.
- [72] Jeremie S Kim, Minesh Patel, Hasan Hassan, Lois Orosa, and Onur Mutlu. D-RaNGe: Using Commodity DRAM Devices to Generate True Random Numbers with Low Latency and High Throughput. In *HPCA*, 2019.
- [73] Jeremie S. Kim, Minesh Patel, Hasan Hassan, and Onur Mutlu. The DRAM Latency PUF: Quickly Evaluating Physical Unclonable Functions by Exploiting the Latency-Reliability Tradeoff in Modern Commodity DRAM Devices. In *HPCA*, 2018.
- [74] F Nisa Bostanci, Ataberk Olgun, Lois Orosa, A Giray Yağlıkcı, Jeremie S Kim, Hasan Hassan, Oğuz Ergin, and Onur Mutlu. DR-STRaNGe: End-to-End System Design for DRAM-Based True Random Number Generators. In *HPCA*, 2022.
- [75] Ataberk Olgun, Juan Gómez Luna, Konstantinos Kanellopoulos, Behzad Salami, Hasan Hassan, Oğuz Ergin, and Onur Mutlu. PiDRAM: A Holistic End-to-end FPGA-based Framework for Processing-in-DRAM. *TACO*, 2022.
- [76] Mustafa F Ali, Akhilesh Jaiswal, and Kaushik Roy. In-Memory Low-Cost Bit-Serial Addition Using Commodity DRAM Technology. In *TCAS I*, 2019.
- [77] Shaahin Angizi and Deliang Fan. GraphiDe: A Graph Processing Accelerator Leveraging In-DRAM-Computing. In *GLSVLSI*, 2019.
- [78] Shuangchen Li, Alvin Oliver Glova, Xing Hu, Peng Gu, Dimin Niu, Krishna T Malladi, Hongzhong Zheng, Bob Brennan, and Yuan Xie. SCOPE: A Stochastic Computing Engine for DRAM-Based In-Situ Accelerator. In *MICRO*, 2018.
- [79] Arun Subramanian and Reetuparna Das. Parallel Automata Processor. In *ISCA*, 2017.
- [80] Yue Zha and Jing Li. Hyper-AP: Enhancing Associative Processing through a Full-Stack Optimization. In *ISCA*, 2020.
- [81] Daichi Fujiki, Scott Mahlke, and Reetuparna Das. In-Memory Data Parallel Processor. In *ASPLOS*, 2018.
- [82] Lois Orosa, Yaohua Wang, Mohammad Sadrosadati, Jeremie S. Kim, Minesh Patel, Ivan Puddu, Haocong Luo, Kaveh Razavi, Juan Gómez-Luna, Hasan Hassan, Nika Mansouri-Ghiasi, Saugata Ghose, and Onur Mutlu. CODIC: A Low-Cost Substrate for Enabling Custom In-DRAM Functionalities and Optimizations. In *2021 ACM/IEEE 48th Annual International Symposium on Computer Architecture (ISCA)*, 2021.
- [83] Mrigank Sharad, Deliang Fan, and Kaushik Roy. Ultra low power associative computing with spin neurons and resistive crossbar memory. In *Proceedings of the 50th Annual Design Automation Conference*, 2013.
- [84] Seyyed Hossein SeyyedAghaei Rezaei, Mehdi Modarressi, Rachata Ausavarungnirun, Mohammad Sadrosadati, Onur Mutlu, and Masoud Daneshdatab. NoM: Network-on-Memory for Inter-Bank Data Transfer in Highly-Banked Memories. In *CAL*, 2020.
- [85] Congming Gao, Xin Xin, Youyou Lu, Youtao Zhang, Jun Yang, and Jiwu Shu. Parabit: processing parallel bitwise operations in nand flash memory based ssds. In *MICRO-54: 54th Annual IEEE/ACM International Symposium on Microarchitecture*, 2021.
- [86] Won Ho Choi, Pi-Feng Chiu, Wen Ma, Gertjan Hemink, Tung Thanh Hoang, Martin Lueker-Boden, and Zvonimir Bandic. An In-Flash Binary Neural Network Accelerator with SLC NAND Flash Array. In *ISCAS*, 2020.
- [87] Runze Han, Peng Huang, Yachen Xiang, Chen Liu, Zhen Dong, Zhiqiang Su, Yongbo Liu, Lu Liu, Xiaoyan Liu, and Jinfeng Kang. A Novel Convolution Computing Paradigm Based on NOR Flash Array with High Computing Speed and Energy Efficiency. *TCAS-I*, 2019.
- [88] Farnood Merrikh-Bayat, Xinjie Guo, Michael Klachko, Mirko Prezioso, Konstantin K Likharev, and Dmitri B Strukov. High-Performance Mixed-Signal Neurocomputing with Nanoscale Floating-Gate Memory Cell Arrays. *TNNLS*, 2017.
- [89] Panni Wang, Feng Xu, Bo Wang, Bin Gao, Huaqiang Wu, He Qian, and Shimeng Yu. Three-Dimensional NAND Flash for Vector–Matrix Multiplication. *TVLSI*, 2018.
- [90] Hang-Ting Lue, Po-Kai Hsu, Ming-Liang Wei, Teng-Hao Yeh, Pei-Ying Du, Wei-Chen Chen, Keh-Chung Wang, and Chih-Yuan Lu. Optimal Design Methods to Transform 3D NAND Flash into a High-Density, High-Bandwidth and Low-Power Nonvolatile Computing in Memory (nvCIM) Accelerator for Deep-Learning Neural Networks (DNN). In *IEDM*, 2019.
- [91] Shine Kim, Yunho Jin, Gina Sohn, Jonghyun Bae, Tae Jun Ham, and Jae W Lee. Behemoth: A Flash-Centric Training Accelerator for Extreme-Scale DNNs. In *FAST*, 2021.
- [92] Shaodi Wang. MemCore: Computing-in-Flash Design for Deep Neural Network Acceleration. In *EDTM*, 2022.
- [93] Runze Han, Yachen Xiang, Peng Huang, Yihao Shan, Xiaoyan Liu, and Jinfeng Kang. Flash Memory Array for Efficient Implementation of Deep Neural Networks. *Adv. Intell. Syst.*, 2021.
- [94] Myeonggu Kang, Hyeonuk Kim, Hyein Shin, Jaehyeong Sim, Kyeonghan Kim, and Lee-Sup Kim. S-FLASH: A NAND Flash-Based Deep Neural Network Accelerator Exploiting Bit-Level Sparsity. *TC*, 2021.
- [95] Sung-Tae Lee and Jong-Ho Lee. Neuromorphic Computing Using NAND Flash Memory Architecture with Pulse Width Modulation Scheme. *Front. Neurosci.*, 2020.
- [96] Hunjun Lee, Minseop Kim, Dongmoon Min, Joonsung Kim, Jongwon Back, Honam Yoo, Jong-Ho Lee, and Jangwoo Kim. 3D-FPIM: An Extreme Energy-Efficient DNN Acceleration System Using 3D NAND Flash-Based In-Situ PIM Unit. In *MICRO*, 2022.
- [97] Xin Si, Win-San Khwa, Jia-Jing Chen, Jia-Fang Li, Xiaoyu Sun, Rui Liu, Shimeng Yu, Hiroyuki Yamauchi, Qiang Li, and Meng-Fan Chang. A Dual-Split 6T SRAM-Based Computing-in-Memory Unit-Macro with Fully Parallel Product-Sum Operation for Binarized DNN Edge Processors. *TCAS-I*, 2019.
- [98] William Andrew Simon, Yasir Mahmood Qureshi, Marco Rios, Alexandre Levisse, Marina Zapater, and David Atienza. BLADE: An In-Cache Computing Architecture for Edge Devices. *TC*, 2020.
- [99] Anirban Nag, CN Ramachandra, Rajeev Balasubramonian, Ryan Stutsman, Edouard Giacomini, Hari Kambalashubramanyam, and Pierre-Emmanuel Gaillardon. Gen-Cache: Leveraging In-Cache Operators for Efficient Sequence Alignment. In *MICRO*, 2019.
- [100] Xiaowei Wang, Jiecao Yu, Charles Augustine, Ravi Iyer, and Reetuparna Das. Bit Prudent In-Cache Acceleration of Deep Convolutional Neural Networks. In *HPCA*, 2019.
- [101] Khalid Al-Hawaj, Olalekan Afuye, Shady Agwa, Alyssa Apsel, and Christopher Batten. Towards a Reconfigurable Bit-Serial/Bit-Parallel Vector Accelerator Using In-Situ Processing-in-SRAM. In *ISCAS*, 2020.
- [102] Mingu Kang, Min-Sun Keel, Naresh R Shanbhag, Sean Eilert, and Ken Curewitz. An Energy-Efficient VLSI Architecture for Pattern Recognition via Deep Embedding of Computation in SRAM. In *ICASSP*, 2014.
- [103] Hyunjoon Kim, Taegeun Yoo, Tony Tae-Hyoung Kim, and Bongjin Kim. Colonnade: A Reconfigurable SRAM-Based Digital Bit-Serial Compute-in-Memory Macro for Processing Neural Networks. *JSSC*, 2021.
- [104] Zhewei Jiang, Shihui Yin, Jae-Sun Seo, and Mingoo Seok. C3SRAM: An In-Memory-Computing SRAM Macro Based on Robust Capacitive Coupling Computing Mechanism. *JSSC*, 2020.
- [105] Supreet Jeloka, Naveen Bharathwaj Akes, Dennis Sylvester, and David Blaauw. A 28 nm Configurable Memory (TCAM/BCAM/SRAM) Using Push-Rule 6T Bit Cell Enabling Logic-in-Memory. *JSSC*, 2016.
- [106] Zhengrong Wang, Christopher Liu, Aman Arora, Lizy John, and Tony Nowatzki. Infinity Stream: Portable and Programmer-Friendly In-/Near-Memory Fusion. In *ASPLOS*, 2023.
- [107] Mingu Kang, Eric P Kim, Min-sun Keel, and Naresh R Shanbhag. Energy-Efficient and High Throughput Sparse Distributed Memory Architecture. In *ISCAS*, 2015.
- [108] Mohsen Imani, Saikishan Pampana, Saransh Gupta, Minxuan Zhou, Yeseong Kim, and Tajana Rosing. DUAL: Acceleration of Clustering Algorithms Using Digital-Based Processing in-Memory. In *MICRO*, 2020.
- [109] Kevin K Chang, Prashant J Nair, Donghyuk Lee, Saugata Ghose, Moinuddin K Qureshi, and Onur Mutlu. Low-Cost Inter-Linked Subarrays (LISA): Enabling Fast Inter-Subarray Data Movement in DRAM. In *HPCA*, 2016.
- [110] Nastaran Hajinazar, Geraldo F Oliveira, Sven Gregorio, João Dimis Ferreira, Nika Mansouri Ghiasi, Minesh Patel, Mohammed Alser, Saugata Ghose, Juan Gómez-Luna, and Onur Mutlu. SIMDRAM: A Framework for Bit-Serial SIMD Processing Using DRAM. In *ASPLOS*, 2021.
- [111] Quan Deng, Youtao Zhang, Minxuan Zhang, and Jun Yang. LAcc: Exploiting Lookup Table-Based Fast and Accurate Vector Multiplication in DRAM-Based CNN Accelerator. In *DAC*, 2019.
- [112] Purab Ranjan Sutradhar, Sathwika Bavikadi, Mark Connolly, Savankumar Prajapati, Mark A Indovina, Sai Manoj Pudukotai Dinakarrao, and Amlan Ganguly. Look-Up-Table Based Processing-in-Memory Architecture with Programmable Precision-Scaling for Deep Learning Applications. *TPDS*, 2021.
- [113] Purab Ranjan Sutradhar, Mark Connolly, Sathwika Bavikadi, Sai Manoj Pudukotai Dinakarrao, Mark A Indovina, and Amlan Ganguly. pPIM: A Programmable Processor-in-Memory Architecture with Precision-Scaling For Deep Learning. In *CAL*, 2020.
- [114] Xiangjun Peng, Yaohua Wang, and Ming-Chang Yang. Chopper: A compiler infrastructure for programmable bit-serial simd processing using memory in dram. In *2023 IEEE International Symposium on High-Performance Computer Architecture (HPCA)*, 2023.
- [115] Taha Shahroodi, Gagandeep Singh, Mahdi Zahedi, Haiyu Mao, Joel Lindegger, Can Firtina, Stephan Wong, Onur Mutlu, and Said Hamdioui. Swordfish: A Framework for Evaluating Deep Neural Network-Based Basecalling Using Computation-In-Memory with Non-Ideal Memristors. In *MICRO*, 2023.
- [116] Ivan Fernandez, Christina Giannoula, Aditya Manglik, Ricardo Quisilant, Nika Mansouri Ghiasi, Juan Gómez-Luna, Eladio Gutierrez, Oscar Plata, and Onur Mutlu. MATSA: An MRAM-Based Energy-Efficient Accelerator for Time Series Analysis. *IEEE Access*, 2024.
- [117] Ismail Emir Yuksek, Yahya Can Tugrul, Ataberk Olgun, F. Nisa Bostanci, A. Giray Yağlıkcı, Geraldo F. de Oliveira, Haocong Luo, Juan Gomez Luna, Mohammad Sadrosadati, and Onur Mutlu. Functionally-Complete Boolean Logic in Real DRAM Chips: Experimental Characterization and Analysis. In *HPCA*, 2024.
- [118] Ismail Emir Yuksek, Ataberk Olgun, F. Nisa Bostanci, Oguzhan Canpolat, Geraldo F. Oliveira, Mohammad Sadrosadati, A. Giray Yağlıkcı, and Onur Mutlu. In-DRAM

- True Random Number Generation Using Simultaneous Multiple-Row Activation: An Experimental Study of Real DRAM Chips. In *ICCD*, 2025.
- [119] Ismail Emir Yuksel, Yahya Can Tugrul, F. Nisa Bostanci, Geraldo F. de Oliveira, A. Giray Yağlıkçı, Ataberk Olgun, Melina Soysal, Haocong Luo, Juan Gomez Luna, Mohammad Sadrosadati, and Onur Mutlu. Simultaneous Many-Row Activation in Off-the-Shelf DRAM Chips: Experimental Characterization and Analysis. In *DSN*, 2024.
- [120] Daichi Tokuda, Ismail Emir Yuksel, Tatsuya Kubo, Ataberk Olgun, Haocong Luo, Nisa Bostanci, Jikun Wang, Abdullah Giray Yağlıkçı, Shinya Takamaeda-Yamazaki, and Onur Mutlu. PuDGhost: Experimental Analysis of Computation Result Corruption in Processing-using-DRAM Operations on Real DRAM Chips and Implications for Future Systems. In *ISCA*, 2026.
- [121] Daichi Tokuda, Tatsuya Kubo, Ismail Emir Yuksel, Ataberk Olgun, Haocong Luo, Tomoya Nagatani, Geraldo Francisco De Oliveira Junior, Abdullah Giray Yağlıkçı, Mohammad Sadrosadati, Onur Mutlu, and Shinya Takamaeda-Yamazaki. Clutch: High Performance Vector-Scalar Comparison using DRAM via Chunked Temporal Coding. In *ICS*, 2026.
- [122] Peiming Yang, Sankeerth Durvasula, Ivan Fernandez, Mohammad Sadrosadati, Onur Mutlu, Gennady Pekhimenko, and Christina Giannoula. DCC: Data-Centric Compilation of Machine Learning Kernels for Processing-In-Memory Architectures. In *ISCA*, 2026.
- [123] Ismail Emir Yuksel, Ataberk Olgun, Behzad Salami, F Bostanci, Yahya Can Tuğrul, A Giray Yağlıkçı, Nika Mansouri Ghiasi, Onur Mutlu, and Oğuz Ergin. TuRaN: True Random Number Generation using Supply Voltage Underscaling in SRAMs. *arXiv*, 2022.
- [124] Berkin Akin, James C Hoe, and Franz Franchetti. HAMLt: Hardware Accelerated Memory Layout Transform within 3D-Stacked DRAM. In *HPEC*, 2014.
- [125] Berkin Akin, Franz Franchetti, and James C Hoe. Data Reorganization in Memory using 3D-stacked DRAM. In *ISCA*, 2015.
- [126] Amirali Boroumand. *Practical Mechanisms for Reducing Processor-Memory Data Movement in Modern Workloads*. PhD thesis, 2020.
- [127] H. Asghari-Moghaddam, A. Farmahini-Farahani, K. Morrow, et al. Near-DRAM Acceleration with Single-ISA Heterogeneous Processing in Standard Memory Modules. *IEEE Micro*, 2016.
- [128] Hadi Asghari-Moghaddam, Young Hoon Son, Jung Ho Ahn, and Nam Sung Kim. Chameleon: Versatile and Practical Near-DRAM Acceleration Architecture for Large Memory Systems. In *MICRO*, 2016.
- [129] Erfan Azarkhish, Christoph Pfister, Davide Rossi, Igor Loi, and Luca Benini. Logic-Base Interconnect Design for Near Memory Computing in the Smart Memory Cube. *IEEE VLSI*, 2016.
- [130] Erfan Azarkhish, Davide Rossi, Igor Loi, and Luca Benini. Neurostream: Scalable and Energy Efficient Deep Learning with Smart Memory Cubes. *TPDS*, 2018.
- [131] Oreoluwatomiwa O Babarinsa and Stratos Idreos. JAFAR: Near-Data Processing for Databases. In *SIGMOD*, 2015.
- [132] M. A. Z. Alves, P. C. Santos, F. B. Moreira, and others. Saving Memory Movements Through Vector Processing in the DRAM. In *Int. Conf. on Compilers, Architecture and Synthesis for Embedded Systems*, 2015.
- [133] Seunghwan Cho, Haerang Choi, Eunhyeok Park, Hyunsung Shin, and Sungjoo Yoo. McDRAM v2: In-Dynamic Random Access Memory Systolic Array Accelerator to Address the Large Model Problem in Deep Neural Networks on the Edge. *IEEE Access*, 2020.
- [134] D. G. Elliott, M. Stumm, W. M. Snelgrove, et al. Computational RAM: Implementing Processors in Memory. *Design and Test of Computers*, 1999.
- [135] Guohao Dai, Tianhao Huang, Yuze Chi, Jishen Zhao, Guangyu Sun, Yongpan Liu, Yu Wang, Yuan Xie, and Huazhong Yang. GraphH: A Processing-in-Memory Architecture for Large-Scale Graph Processing. *TCAD*, 2018.
- [136] João Paulo C de Lima, Paulo Cesar Santos, Marco AZ Alves, Antonio Beck, and Luigi Carro. Design Space Exploration for PIM Architectures in 3D-Stacked Memories. In *CF*, 2018.
- [137] Fabrice Devaux. The True Processing in Memory Accelerator. In *Hot Chips*, 2019.
- [138] A. Farmahini-Farahani, J. H. Ahn, K. Compton, and N. S. Kim. DRAMA: an architecture for accelerated processing near memory. *Computer Architecture Letters*, (99), 2014.
- [139] Mario Drumond, Alexandros Daglis, Nooshin Mirzadeh, Dmitrii Ustiugov, Javier Picorel, Babak Falsafi, Boris Grot, and Dionisios Pnevmatikatos. The Mondrian Data Engine. In *ISCA*, 2017.
- [140] Amin Farmahini-Farahani, Jung Ho Ahn, Katherine Morrow, and Nam Sung Kim. NDA: Near-DRAM Acceleration Architecture Leveraging Commodity DRAM Devices and Standard Memory Modules. In *HPCA*, 2015.
- [141] Ivan Fernandez, Ricardo Quisiant, Christina Giannoula, Mohammed Alser, Juan Gomez-Luna, Eladio Gutierrez, Oscar Plata, and Onur Mutlu. NATSA: A Near-Data Processing Accelerator for Time Series Analysis. In *ICCD*, 2020.
- [142] Mingyu Gao and Christos Kozyrakis. HRL: Efficient and Flexible Reconfigurable Logic for Near-Data Processing. In *HPCA*, 2016.
- [143] Mingyu Gao, Jing Pu, Xuan Yang, Mark Horowitz, and Christos Kozyrakis. TETRIS: Scalable and Efficient Neural Network Acceleration with 3D Memory. In *ASPLOS*, 2017.
- [144] Christina Giannoula, Ivan Fernandez, Juan Gómez-Luna, Nectarios Koziris, Georgios Goumas, and Onur Mutlu. SparseP: Towards Efficient Sparse Matrix Vector Multiplication on Real Processing-in-Memory Systems. In *SIGMETRICS*, 2022.
- [145] Juan Gómez-Luna, Izzat El Hajj, Ivan Fernandez, Christina Giannoula, Geraldo F Oliveira, and Onur Mutlu. Benchmarking Memory-Centric Computing Systems: Analysis of Real Processing-in-Memory Hardware. In *CUT*, 2021.
- [146] Peng Gu, Xinfeng Xie, Yufei Ding, Guoyang Chen, Weifeng Zhang, Dimin Niu, and Yuan Xie. iPIM: Programmable In-Memory Image Processing Accelerator using Near-Bank Architecture. In *ISCA*, 2020.
- [147] Qi Guo, Nikolaos Alachiotis, Berkin Akin, Fazle Sadi, Guanglin Xu, Tze Meng Low, Larry Pileggi, James C Hoe, and Franz Franchetti. 3D-Stacked Memory-Side Acceleration: Accelerator and System Design. In *WoNDP*, 2014.
- [148] Kevin Hsieh, Samira Khan, Nandita Vijaykumar, Kevin K Chang, Amirali Boroumand, Saugata Ghose, and Onur Mutlu. Accelerating Pointer Chasing in 3D-Stacked Memory: Challenges, Mechanisms, Evaluation. In *ICCD*, 2016.
- [149] Jiayi Huang, Ramprakash Reddy Puli, Pritam Majumder, Sungkeun Kim, Rahul Boyapati, Ki Hwan Yum, and Eun Jung Kim. Active-Routing: Compute on the Way for Near-Data Processing. In *HPCA*, 2019.
- [150] Yu Huang, Long Zheng, Pengcheng Yao, Jieshan Zhao, Xiaofei Liao, Hai Jin, and Jingling Xue. A Heterogeneous PIM Hardware-Software Co-Design for Energy-Efficient Graph Processing. In *IPDPS*, 2020.
- [151] D. Patterson, T. Anderson, N. Cardwell, et al. A Case for Intelligent RAM. *IEEE Micro*, 1997.
- [152] Liu Ke, Xuan Zhang, Jinin So, Jong-Geon Lee, Shin-Haeng Kang, Sukhan Lee, Songyi Han, Yeongon Cho, Jin Hyun Kim, Yongsuk Kwon, et al. Near-Memory Processing in Action: Accelerating Personalized Recommendation with AxDIMM. *IEEE Micro*, 2021.
- [153] Chad D Kersey, Hyesoon Kim, and Sudhakar Yalamanchili. Lightweight SIMT Core Designs for Intelligent 3D Stacked DRAM. In *MEMSYS*, 2017.
- [154] Young-Cheon Kwon, Suk Han Lee, Jaehoon Lee, Sang-Hyuk Kwon, Je Min Ryu, Jong-Pil Son, O Seongil, Hak-Soo Yu, Haesuk Lee, Soo Young Kim, et al. A 20nm 6GB Function-in-Memory DRAM, Based on HBM2 with a 1.2TFLOPS Programmable Computing Unit Using Bank-Level Parallelism, for Machine Learning Applications. In *ISSCC*, 2021.
- [155] Amirali Boroumand, Saugata Ghose, Minesh Patel, Hasan Hassan, Brandon Lucia, Kevin Hsieh, Krishna T Malladi, Hongzhong Zheng, and Onur Mutlu. LazyPIM: An Efficient Cache Coherence Mechanism for Processing-in-Memory. In *CAL*, 2016.
- [156] Sukhan Lee, Shin-haeng Kang, Jaehoon Lee, Hyeonsu Kim, Eojin Lee, Seungwoo Seo, Hosang Yoon, Seungwon Lee, Kyounghwan Lim, Hyunsung Shin, et al. Hardware Architecture and Software Stack for PIM Based on Commercial DRAM Technology: Industrial Product. In *ISCA*, 2021.
- [157] Jie Li, Xi Wang, Antonino Tumeo, Brody Williams, John D Leidel, and Yong Chen. PIMS: A Lightweight Processing-in-Memory Accelerator for Stencil Computations. In *MEMSYS*, 2019.
- [158] Jiawen Liu, Hengyu Zhao, Matheus A Ogleari, Dong Li, and Jishen Zhao. Processing-in-Memory for Energy-Efficient Neural Network Training: A Heterogeneous Approach. In *MICRO*, 2018.
- [159] S. H. Pugsley, J. Jestes, H. Zhang, R. Balasubramonian, et al. NDC: Analyzing the Impact of 3D-Stacked Memory+Logic Devices on MapReduce Workloads. In *ISPASS*, 2014.
- [160] Geraldo F Oliveira, Paulo C Santos, Marco AZ Alves, and Luigi Carro. NIM: An HMC-Based Machine for Neuron Computation. In *ARC*, 2017.
- [161] Dimin Niu, Shuangchen Li, Yuhao Wang, Wei Han, Zhe Zhang, Yijin Guan, Tianchan Guan, Fei Sun, Fei Xue, Lide Duan, et al. 184QPS/W 64Mb/mm² 3D Logic-to-DRAM Hybrid Bonding with Process-Near-Memory Engine for Recommendation System. In *ISSCC*, 2022.
- [162] Ashutosh Pattnaik, Xulong Tang, Adwait Jog, Onur Kayiran, Asit K Mishra, Mahmut T Kandemir, Onur Mutlu, and Chita R Das. Scheduling Techniques for GPU Architectures with Processing-in-Memory Capabilities. In *PACT*, 2016.
- [163] P. C. Santos, G. F. Oliveira, D. G. Tomé, M. A. Z. Alves, E. C. Almeida, and L. Carro. Operand Size Reconfiguration for Big Data Processing in Memory. In *DATE*, 2017.
- [164] Hyunsung Shin, Dongyung Kim, Eunhyeok Park, Sungcho Park, Yongsik Park, and Sungjoo Yoo. McDRAM: Low Latency and Energy-Efficient Matrix Computations in DRAM. *IEEE TCADICS*, 2018.
- [165] Gagandeep Singh, Juan Gómez-Luna, Giovanni Mariani, Geraldo F Oliveira, Stefania Corda, Sander Stuijk, Onur Mutlu, and Henk Corporaal. NAPEL: Near-Memory Computing Application Performance Prediction via Ensemble Learning. In *DAC*, 2019.
- [166] Gagandeep Singh, Dionysios Diamantopoulos, Christoph Hagleitner, Juan Gomez-Luna, Sander Stuijk, Onur Mutlu, and Henk Corporaal. NERO: A Near High-Bandwidth Memory Stencil Accelerator for Weather Prediction Modeling. In *FPL*, 2020.
- [167] S. Lee, K. Kim, S. Oh, J. Park, G. Hong, D. Ka, K. Hwang, J. Park, K. Kang, J. Kim, J. Jeon, N. Kim, Y. Kwon, K. Vladimirov, W. Shin, J. Won, M. Lee, H. Joo, et al. A 1nm 1.25V 8Gb, 16Gb/s/pin GDDR6-Based Accelerator-in-Memory Supporting 1TFLOPS MAC Operation and Various Activation Functions for Deep-Learning Applications. In *ISSCC*, 2022.
- [168] Q. Zhu, T. Graf, H. E. Sumbul, L. Pileggi, and F. Franchetti. Accelerating Sparse Matrix-Matrix Multiplication with 3D-Stacked Logic-in-Memory Hardware. In *HPEC*, 2013.
- [169] Weiyi Sun, Zhaoshi Li, Shouyi Yin, Shaojun Wei, and Leibo Liu. ABC-DIMM: Alleviating the Bottleneck of Communication in DIMM-Based Near-Memory Processing with Inter-DIMM Broadcast. In *ISCA*, 2021.
- [170] Christina Giannoula, Nandita Vijaykumar, Nikela Papadopoulou, Vasileios Karakostas, Ivan Fernandez, Juan Gómez-Luna, Lois Orosa, Nectarios Koziris, Georgios Goumas, and Onur Mutlu. SynCron: Efficient Synchronization Support for Near-Data-Processing Architectures. In *HPCA*, 2021.
- [171] Dongping Zhang, Nuwan Jayasena, Alexander Lyashevsky, Joseph L Greathouse, Lifan Xu, and Michael Ignatowski. TOP-PIM: Throughput-Oriented Programmable Processing in Memory. In *HPDC*, 2014.
- [172] Po-An Tsai, Changping Chen, and Daniel Sanchez. Adaptive Scheduling for Systems with Asymmetric Memory Hierarchies. In *MICRO*, 2018.

- [173] S. L. Xi, O. Babarinsa, M. Athanassoulis, and S. Idreos. Beyond the Wall: Near-Data Processing for Databases. In *Int. Workshop on Data Management on New Hardware*, 2015.
- [174] Mingxing Zhang, Youwei Zhuo, Chao Wang, Mingyu Gao, Yongwei Wu, Kang Chen, Christos Kozyrakis, and Xuehai Qian. GraphP: Reducing Communication for PIM-Based Graph Processing with Efficient Data Partition. In *HPCA*, 2018.
- [175] Youwei Zhuo, Chao Wang, Mingxing Zhang, Rui Wang, Dimin Niu, Yanzhi Wang, and Xuehai Qian. GraphQ: Scalable PIM-Based Graph Processing. In *MICRO*, 2019.
- [176] Hongyeol Lim and Giho Park. Triple Engine Processor (TEP): A Heterogeneous Near-Memory Processor for Diverse Kernel Operations. *TACO*, 2017.
- [177] Erfan Azarkhish, Davide Rossi, Igor Loi, and Luca Benini. A Case for Near Memory Computation Inside the Smart Memory Cube. In *EMS*, 2016.
- [178] M. A. Z. Alves, M. Diener, P. C. Santos, and L. Carro. Large vector extensions inside the HMC. In *Conf. on Design, Automation & Test in Europe*, 2016.
- [179] Jaeyoung Jang, Jun Heo, Yejin Lee, Jaeyeon Won, Seonghak Kim, Sung Jun Jung, Hakbeom Jang, Tae Jun Ham, and Jae W Lee. Charon: Specialized Near-Memory Processing Architecture for Clearing Dead Objects in Memory. In *MICRO*, 2019.
- [180] R. Nair, S. F. Antao, C. Bertolli, P. Bose, et al. Active Memory Cube: A Processing-in-Memory Architecture for Exascale Systems. *IBM JRD*, 2015.
- [181] Mary Hall, Peter Kogge, Jeff Koller, Pedro Diniz, Jacqueline Chame, Jeff Draper, Jeff LaCoss, John Granacki, Jay Brockman, Apoorv Srivastava, et al. Mapping irregular applications to DIVA, a PIM-based data-intensive architecture. In *SC'99: Proceedings of the 1999 ACM/IEEE Conference on Supercomputing*, 1999.
- [182] Ramyad Hadidi, Lifeng Nai, Hyoung Kim, and Hyesoon Kim. CAIRO: A Compiler-Assisted Technique for Enabling Instruction-Level Offloading of Processing-in-Memory. *TACO*, 2017.
- [183] Paulo C Santos, Geraldo F Oliveira, João P Lima, Marco AZ Alves, Luigi Carro, and Antonio CS Beck. Processing in 3D Memories to Speed Up Operations on Complex Data Structures. In *DATE*, 2018.
- [184] Marco A. Z. Alves, Paulo C. Santos, Matthias Diener, and Luigi Carro. Opportunities and Challenges of Performing Vector Operations Inside the DRAM. In *MEMSYS*, 2015.
- [185] Sang-Woo Jun, Ming Liu, Sungjin Lee, Jamey Hicks, John Ankcorn, Myron King, and Shuotao Xu. Bluedbm: An appliance for big data analytics. *ACM SIGARCH Computer Architecture News*, 2015.
- [186] Duckhwan Kim, Jaeha Kung, Sek Chai, Sudhakar Yamalanchili, and Saibal Mukhopadhyay. Neurocube: A Programmable Digital Neuromorphic Architecture with High-Density 3D Memory. In *ISCA*, 2016.
- [187] Robert H. Dennard. Field-Effect Transistor Memory, 1968.
- [188] Monique Ogburn, Claude Turner, and Pushkar Dahal. Homomorphic Encryption. *PROCS*, 2013.
- [189] Dalia Tourky, Mohamed Elkawagy, and Arabi Keshk. Homomorphic Encryption The "Holy Grail" of Cryptography. In *ICCC*, 2016.
- [190] Craig Gentry and Shai Halevi. Implementing Gentry's Fully Homomorphic Encryption Scheme. In *EUROCRYPT*, 2011.
- [191] Craig Gentry. Fully Homomorphic Encryption using Ideal Lattices. In *STOC*, 2009.
- [192] Marten Van Dijk, Craig Gentry, Shai Halevi, and Vinod Vaikuntanathan. Fully Homomorphic Encryption over the Integers. In *EUROCRYPT*, 2010.
- [193] Dan Boneh, Craig Gentry, Sergey Gorbunov, Shai Halevi, Valeria Nikolaenko, Gil Segev, Vinod Vaikuntanathan, and Dhinakaran Vinayagamurthy. Fully Key-Homomorphic Encryption, Arithmetic Circuit ABE, and Compact Garbled Circuits. *IACR*, 2014.
- [194] Dan Boneh, Craig Gentry, Shai Halevi, Frank Wang, and David J Wu. Private Database Queries using Somewhat Homomorphic Encryption. In *ACNS*, 2013.
- [195] Junfeng Fan and Frederik Vercauteren. Somewhat Practical Fully Homomorphic Encryption. *Cryptology ePrint Archive*, 2012.
- [196] Christoph Keller, Frank Gurkaynak, Hubert Kaeslin, and Norbert Felber. Dynamic Memory-based Physically Unclonable Function for the Generation of Unique Identifiers and True Random Numbers. In *ISCAS*, 2014.
- [197] Soubhagya Sutar, Arnab Raha, Devadatta Kulkarni, Rajeev Shorey, Jeffrey Tew, and Vijay Raghunathan. D-PUF: An Intrinsically Reconfigurable DRAM PUF for Device Authentication and Random Number Generation. In *TECS*, 2018.
- [198] Fatemeh Tehranipoor, Wei Yan, and John A Chandy. Robust Hardware True Random Number Generators using DRAM Remanence Effects. In *HOST*, 2016.
- [199] Charles Eckert, Fatemeh Tehranipoor, and John A Chandy. DRNG: DRAM-based random number generation using its startup value behavior. In *2017 IEEE 60th International Midwest Symposium on Circuits and Systems (MWSCAS)*, 2017.
- [200] BMS Bahar Talukder, Joseph Kerns, Biswajit Ray, Thomas Morris, and Md Tauhidur Rahman. Exploiting DRAM Latency Variations for Generating True Random Numbers. In *ICCE*, 2019.
- [201] Changwoo Pyo, Sungil Pae, and Gyungho Lee. DRAM as Source of Randomness. In *IET*, 2009.
- [202] Wenjie Xiong, André Schaller, Nikolaos A Anagnostopoulos, Muhammad Umair Saleem, Sebastian Gabmeyer, Stefan Katzenbeisser, and Jakob Szefer. Run-time Accessible DRAM PUFs in Commodity Devices. In *CHES*, 2016.
- [203] André Schaller, Wenjie Xiong, Nikolaos Athanasios Anagnostopoulos, Muhammad Umair Saleem, Sebastian Gabmeyer, Boris Škorić, Stefan Katzenbeisser, and Jakob Szefer. Decay-Based DRAM PUFs in Commodity Devices. *TDSC*, 2019.
- [204] W. Liu, Z. Zhang, M. Li, and Z. Liu. A Trustworthy Key Generation Prototype Based on DDR3 PUF for Wireless Sensor Networks. In *IS3C*, 2014.
- [205] Yu Zheng, Zhao Huang, Liang Li, Changjian Xie, Quan Wang, and Zili Wu. Implementation and Analysis of Hybrid DRAM PUFs on FPGA. In *NaNA*, 2021.
- [206] Indra Kumari, Mi-Kyung Oh, Younsung Kang, and Dooho Choi. Rapid Run-Time DRAM PUF Based on Bit-Flip Position for Secure IoT Devices. In *SENSORS*, 2018.
- [207] Nico Mexis, Nikolaos Athanasios Anagnostopoulos, Stefan Katzenbeisser, Elif Bilge Kavun, Sara Tehranipoor, and Tolga Arul. Achieving Error-Free Lightweight Authentication With DRAM-Based Physical Unclonable Functions. *TCAS-I*, 2025.
- [208] B. M. S. Bahar Talukder, Biswajit Ray, Domenic Forte, and Md Tauhidur Rahman. PreLatPUF: Exploiting DRAM Latency Variations for Generating Robust Device Signatures. *IEEE Access*, 2019.
- [209] Maryam S. Hashemian, Bhanu Singh, Francis Wolff, Daniel Weyer, Steve Clay, and Christos Papachristou. A Robust Authentication Methodology Using Physically Unclonable Functions in DRAM Arrays. In *DATE*, 2015.
- [210] Fatemeh Najafi, Masoud Kaveh, Diego Martin, and Mohammad Reza Mosavi. Deep PUF: A Highly Reliable DRAM PUF-Based Authentication for IoT Networks Using Deep Convolutional Neural Networks. *Sensors*, 2021.
- [211] Fatemeh Najafi, Masoud Kaveh, Mohammad Reza Mosavi, Alessandro Brighente, and Mauro Conti. EPUF: An Entropy-Derived Latency-Based DRAM Physical Unclonable Function for Lightweight Authentication in Internet of Things. *TMC*, 2025.
- [212] Jack Miskelly and Máire O'Neill. Fast DRAM PUFs on Commodity Devices. *TCAD*, 2020.
- [213] André Schaller, Wenjie Xiong, Nikolaos Athanasios Anagnostopoulos, Muhammad Umair Saleem, Sebastian Gabmeyer, Stefan Katzenbeisser, and Jakob Szefer. Intrinsic Rowhammer PUFs: Leveraging the Rowhammer Effect for Improved Security. In *HOST*, 2017.
- [214] Bernhard Fischer, Daniel Dorfmeister, Harald Lampesberger, and Eckehard Hermann. Leveraging Rowhammer for Physically Unique and Non-tamperable Device Identification. In *ISM*, 2024.
- [215] Nikolaos Athanasios Anagnostopoulos, Tolga Arul, Yufan Fan, Christian Hatzfeld, André Schaller, Wenjie Xiong, Manishkumar Jain, Muhammad Umair Saleem, Jan Lotichius, Sebastian Gabmeyer, et al. Intrinsic Run-Time Row Hammer PUFs: Leveraging the Row Hammer Effect for Run-Time Cryptography and Improved Security. *Cryptography*, 2018.
- [216] Dawei Li, Di Liu, Yangkun Ren, Ziyi Wang, Yu Sun, Zhenyu Guan, Qianhong Wu, and Jianwei Liu. FPHammer: A Device Identification Framework based on DRAM Fingerprinting. In *TrustCom*, 2023.
- [217] Fei Gao, Georgios Tziantzioulis, and David Wentzlaff. FracDRAM: Fractional Values in Off-the-Shelf DRAM. In *MICRO*, 2022.
- [218] Umüt Baser, Ismail Emir Yuksel, F. Nisa Bostanci, Konstantinos Sgouras, Ataberk Olgun, Emre Hakan Demirli, Zhiheng Yue, Harsh Songara, Oguz Ergin, and Onur Mutlu. In-DRAM Signature Generation Using Simultaneous Multiple-Row Activation: An Experimental Study of Off-The-Shelf DRAM Chips. arXiv, 2026.
- [219] Ismail Emir Yuksel, Akash Sood, Ataberk Olgun, Oguzhan Canpolat, Haocong Luo, Nisa Bostanci, Mohammad Sadrosadati, Giray Yaglikci, and Onur Mutlu. PuDHammer: Experimental Analysis of Read Disturbance Effects of Processing-using-DRAM in Real DRAM Chips. In *ISCA*, 2025.
- [220] F Nisa Bostanci, Konstantinos Kanellopoulos, Ataberk Olgun, A Giray Yağlıkçı, İsmail Emir Yüksel, Nika Mansouri Ghiasi, Zülal Bingöl, Mohammad Sadrosadati, and Onur Mutlu. Revisiting Main Memory-Based Covert and Side Channel Attacks in the Context of Processing-in-Memory. In *DSN*, 2025.
- [221] Y. Kim, R. Daly, J. Kim, C. Fallin, J. H. Lee, D. Lee, C. Wilkerson, K. Lai, and O. Mutlu. Flipping Bits in Memory Without Accessing Them: An Experimental Study of DRAM Disturbance Errors. In *ISCA*, 2014.
- [222] Haocong Luo, Ataberk Olgun, Abdullah Giray Yağlıkçı, Yahya Can Tuğrul, Steve Rhyner, Meryem Banu Cavlak, Joël Lindegger, Mohammad Sadrosadati, and Onur Mutlu. RowPress: Amplifying Read Disturbance in Modern DRAM Chips. In *ISCA*, 2023.
- [223] Ismail Emir Yuksel, Ataberk Olgun, Nisa Bostanci, Haocong Luo, Abdullah Giray Yaglikci, and Onur Mutlu. ColumnDisturb: Understanding Column-based Read Disturbance in Real DRAM Chips and Implications for Future Systems. In *MICRO*, 2025.
- [224] A. Röck. Pseudorandom Number Generators for Cryptographic Applications. Master's thesis, 2005.
- [225] X. Ma, X. Yuan, Z. Cao, B. Qi, and Z. Zhang. Quantum Random Number Generation. *Quantum Inf.*, 2016.
- [226] Mario Stipčević and Çetin Kaya Koç. True random number generators. *Open Problems in Mathematics and Computational Science*, pages 275–315, 2014.
- [227] M. Barangi, J. S. Chang, and P. Mazumder. Straintronics-Based True Random Number Generator for High-Speed and Energy-Limited Applications. *IEEE Trans. Magn.*, 2016.
- [228] S. Tao and E. Dubrova. TVL-TRNG: Sub-Microwatt True Random Number Generator Exploiting Metastability in Ternary Valued Latches. In *ISMVL*, 2017.
- [229] Z. Gutterman, B. Pinkas, and T. Reinman. Analysis of the Linux Random Number Generator. In *SP*, 2006.
- [230] V. von Kaenel and T. Takayanagi. Dual True Random Number Generators for Cryptographic Applications Embedded on a 200 Million Device Dual CPU SOC. In *CICC*, 2007.
- [231] J. Kim, T. Ahmed, H. Nili, N. D. Truong, J. Yang, D. S. Jeong, S. Sriram, D. C. Ranasinghe, and O. Kavehei. Nano-Intrinsic True Random Number Generation. *arXiv preprint arXiv:1701.06020*, 2017.
- [232] M. Drutarovsky and P. Galajda. A Robust Chaos-based True Random Number Generator Embedded in Reconfigurable Switched-Capacitor Hardware. In *Radiotelektronika*, 2007.
- [233] S. H. Kwok and E. Y. Lam. FPGA-based High-speed True Random Number Generator for Cryptographic Applications. In *TENCON*, 2006.
- [234] A. Cherkouki, V. Fischer, L. Fesquet, and A. Aubert. A Very High Speed True Random Number Generator with Entropy Assessment. In *CHES*, 2013.
- [235] T. Zhang, M. Yin, C. Xu, X. Lu, X. Sun, Y. Yang, and R. Huang. High-speed True

- Random Number Generation Based on Paired Memristors for Security Electronics. *Nanotechnology*, 2017.
- [236] Q. Labs. Random Number Generators White Paper, 2015.
- [237] Ç. K. Koc. About Cryptographic Engineering. In *Cryptographic Engineering*. 2009.
- [238] H. C. v. Tilborg and S. Jajodia. *Encyclopedia of Cryptography and Security*. 2011.
- [239] P. Chevalier, C. Menard, and B. Dorval. Random number generator, 1974. US Patent 3,790,768.
- [240] D. E. Knuth. The art of computer programming, 2: Seminumerical algorithms, Addison Wesley, 1998.
- [241] K. H. Tsoi, K. Leung, and P. H. W. Leong. Compact FPGA-based True and Pseudo Random Number Generators. In *FCCM*, 2003.
- [242] M. Matsumoto and T. Nishimura. Mersenne Twister: A 623-dimensionally Equidistributed Uniform Pseudo-random Number Generator. *TOMACS*, 1998.
- [243] L. Blum, M. Blum, and M. Shub. A Simple Unpredictable Pseudo-Random Number Generator. *SIAM Journal on Computing*, 1986.
- [244] M. Mascagni and A. Srinivasan. Algorithm 806: SPRNG: A Scalable Library for Pseudorandom Number Generation. *TOMS*, 2000.
- [245] G. L. Steele Jr, D. Lea, and C. H. Flood. Fast Splittable Pseudorandom Number Generators. In *OOPSLA*, 2014.
- [246] G. Marsaglia et al. Xorshift RNGs. *Journal of Statistical Software*, 2003.
- [247] Y. Wang, W. Yu, S. Wu, G. Malysa, G. E. Suh, and E. C. Kan. Flash Memory for Ubiquitous Hardware Security Functions: True Random Number Generation and Device Fingerprints. In *SP*, 2012.
- [248] B. Ray and A. Milenković. True Random Number Generation Using Read Noise of Flash Memory Cells. *IEEE Trans. on Electron Devices*, 2018.
- [249] D. E. Holcomb, W. P. Burleson, and K. Fu. Initial SRAM State as a Fingerprint and Source of True Random Numbers for RFID Tags. In *RFID*, 2007.
- [250] D. E. Holcomb, W. P. Burleson, and K. Fu. Power-Up SRAM State as an Identifying Fingerprint and Source of True Random Numbers. *TC*, 2009.
- [251] V. van der Leest, E. van der Sluis, G.-J. Schrijen, P. Tuyls, and H. Handschuh. Efficient Implementation of True Random Number Generator Based on SRAM PUFs. In *Cryptography and Security: From Theory to Applications*. 2012.
- [252] J. J. M. Chan, B. Sharma, J. Lv, G. Thomas, R. Thulasiram, and P. Thulasiraman. True Random Number Generator using GPUs and Histogram Equalization Techniques. In *HPCC*, 2011.
- [253] S. Tzeng and L. Wei. Parallel White Noise Generation on a GPU via Cryptographic Hash. In *ISD*, 2008.
- [254] J. S. Teh, A. Samsudin, M. Al-Mazrooe, and A. Akhavan. GPUs and Chaos: A New True Random Number Generator. *Nonlinear Dynamics*, 2015.
- [255] M. Majzoobi, F. Koushanfar, and S. Devadas. FPGA-based True Random Number Generation using Circuit Metastability with Adaptive Feedback Control. In *CHES*, 2011.
- [256] P. Z. Wiczorek. An FPGA Implementation of the Resolve Time-based True Random Number Generator with Quality Control.
- [257] P. P. Chu and R. E. Jones. Design Techniques of FPGA Based Random Number Generator. In *MAPLD*, 1999.
- [258] T. Amaki, M. Hashimoto, and T. Onoye. An Oscillator-based True Random Number Generator with Process and Temperature Tolerance. In *DAC*, 2015.
- [259] S. K. Mathew, S. Srinivasan, M. A. Anders, H. Kaul, S. K. Hsu, F. Sheikh, A. Agarwal, S. Satpathy, and R. K. Krishnamurthy. 2.4 Gbps, 7 mW All-digital PVT-variation Tolerant True Random Number Generator for 45 nm CMOS High-performance Microprocessors. *JSSC*, 2012.
- [260] R. Brederlow, R. Prakash, C. Paulus, and R. Thewes. A Low-power True Random Number Generator using Random Telegraph Noise of Single Oxide-traps. In *ISSCC*, 2006.
- [261] C. Tokunaga, D. Blaauw, and T. Mudge. True Random Number Generator with a Metastability-based Quality Control. *JSSC*, 2008.
- [262] M. Bucci, L. Germani, R. Luzzi, A. Trifiletti, and M. Varanano. A High-speed Oscillator-based Truly Random Number Source for Cryptographic Applications on a Smart Card IC. *TC*, 2003.
- [263] Mudit Bhargava, Kaship Sheikh, and Ken Mai. Robust True Random Number Generator using Hot-carrier Injection Balanced Metastable Sense Amplifiers. In *HOST*, 2015.
- [264] D. Kinniment and E. Chester. Design of an On-chip Random Number Generator using Metastability. In *ESSCIRC*, 2002.
- [265] J. Holleman, S. Bridges, B. P. Otis, and C. Diorio. A 3mu W CMOS True Random Number Generator with Adaptive Floating-Gate Offset Cancellation. *JSSC*, 2008.
- [266] L. Dorrendorf, Z. Gutterman, and B. Pinkas. Cryptanalysis of the Windows Random Number Generator. In *CCS*, 2007.
- [267] P. Lacharme, A. Rock, V. Strubel, and M. Videau. The Linux Pseudorandom Number Generator Revisited, 2012.
- [268] F. Pareschi, G. Setti, and R. Rovatti. A Fast Chaos-based True Random Number Generator for Cryptographic Applications. In *ESSCIRC*, 2006.
- [269] K. Yang, D. Blaauw, and D. Sylvester. An All-digital Edge Racing True Random Number Generator Robust Against PVT Variations. *JSSC*, 2016.
- [270] FIPS, PUB. 180-2: Secure hash standard (SHS). *US Department of Commerce, National Institute of Standards and Technology (NIST)*, 2012.
- [271] Ataberk Olgun, Hasan Hassan, A Giray Yağlıkcı, Yahya Can Tuğrul, Lois Orosa, Haocong Luo, Minesh Patel, Oguz Ergin, and Onur Mutlu. DRAM Bender: An Extensible and Versatile FPGA-based Infrastructure to Easily Test State-of-the-art DRAM Chips. *TCAD*, 2023.
- [272] SAFARI Research Group. DRAM Bender – GitHub Repository. <https://github.com/CMU-SAFARI/DRAM-Bender>, 2022.
- [273] Hasan Hassan, Nandita Vijaykumar, Samira Khan, Saugata Ghose, Kevin Chang, Gennady Pekhimenko, Donghyuk Lee, Oguz Ergin, and Onur Mutlu. SoftMC: A Flexible and Practical Open-Source Infrastructure for Enabling Experimental DRAM Studies. In *HPCA*, 2017.
- [274] SAFARI Research Group. SoftMC – GitHub Repository. <https://github.com/CMU-SAFARI/softmc>, 2017.
- [275] Lawrence Bassham, Andrew Rukhin, Juan Soto, James Nechvatal, Miles Smid, Stefan Leigh, M Levenson, M Vangel, Nathanael Heckert, and D Banks. A Statistical Test Suite for Random and Pseudorandom Number Generators for Cryptographic Applications. Special Publication (NIST SP), 2010.
- [276] Blaise Gassend, Dwayne Clarke, Marten Van Dijk, and Srinivas Devadas. Silicon Physical Random Functions. In *CCS*, 2002.
- [277] Wei Yan, Fatemeh Tehranipoor, and John A Chandy. A Novel Way to Authenticate Untrusted Integrated Circuits. In *ICCAD*, 2015.
- [278] Soubhagya Sutar, Arnab Raha, and Vijay Raghunathan. D-PUF: An Intrinsically Reconfigurable DRAM PUF for Device Authentication in Embedded Systems. In *CASES*, 2016.
- [279] Jeremie S. Kim, Minesh Patel, Abdullah Giray Yağlıkcı, Hasan Hassan, Roknoddin Azizi, Lois Orosa, and Onur Mutlu. Revisiting RowHammer: An Experimental Analysis of Modern Devices and Mitigation Techniques. In *ISCA*, 2020.
- [280] Lois Orosa, A Giray Yağlıkcı, Haocong Luo, Ataberk Olgun, Jisung Park, Hasan Hassan, Minesh Patel, Jeremie S. Kim, and Onur Mutlu. A Deeper Look into RowHammer's Sensitivities: Experimental Analysis of Real DRAM Chips and Implications on Future Attacks and Defenses. In *MICRO*, 2021.
- [281] Ataberk Olgun, Majd Osseiran, Abdullah Giray Yaglıkci, Yahya Can Tuğrul, Haocong Luo, Steve Rhyner, Behzad Salami, Juan Gomez Luna, and Onur Mutlu. Read Disturbance in High Bandwidth Memory: A Detailed Experimental Study on HBM2 DRAM Chips. In *DSN*, 2024.
- [282] Ataberk Olgun, F. Nisa Bostanci, Ismail Emir Yuksel, Oguzhan Canpolat, Haocong Luo, Geraldo F. Oliveira, A. Giray Yaglıkci, Minesh Patel, and Onur Mutlu. Variable Read Disturbance: An Experimental Analysis of Temporal Variation in DRAM Read Disturbance. In *HPCA*, 2025.
- [283] Haocong Luo, Ataberk Olgun, A Giray Yağlıkcı, Yahya Can Tuğrul, Steve Rhyner, Meryem Banu Cavlak, Joël Lindegger, Mohammad Sadrosadati, and Onur Mutlu. RowPress Vulnerability in Modern DRAM Chips. *IEEE Micro*, 2024.
- [284] Onur Mutlu. The RowHammer Problem and Other Issues We May Face as Memory Becomes Denser. In *DATE*, 2017.
- [285] Onur Mutlu and Jeremie S Kim. RowHammer: A Retrospective. *TCAD*, 2019.
- [286] Onur Mutlu, Ataberk Olgun, and A. Giray Yaglıkci. Fundamentally Understanding and Solving RowHammer. In *ASP-DAC*, 2023.
- [287] A. Giray Yağlıkcı, Haocong Luo, Geraldo F De Oliviera, Ataberk Olgun, Minesh Patel, Jisung Park, Hasan Hassan, Jeremie S Kim, Lois Orosa, and Onur Mutlu. Understanding RowHammer Under Reduced Wordline Voltage: An Experimental Study Using Real DRAM Devices. In *DSN*, 2022.
- [288] Chulseung Lim, Kyungbae Park, and Sanghyeon Baeg. Active Precharge Hammering to Monitor Displacement Damage Using High-Energy Protons in 3x-nm SDRAM. *TNS*, 2017.
- [289] Kyungbae Park, Donghyuk Yun, and Sanghyeon Baeg. Statistical Distributions of Row-Hammering Induced Failures in DDR3 Components. *Microelectronics Reliability*, 2016.
- [290] Kyungbae Park, Chulseung Lim, Donghyuk Yun, and Sanghyeon Baeg. Experiments and Root Cause Analysis for Active-Precharge Hammering Fault in DDR3 SDRAM under 3xnm Technology. *Microelectronics Reliability*, 2016.
- [291] Seong-Wan Ryu, Kyungkyu Min, Jungho Shin, Heimi Kwon, Donghoon Nam, Taekyung Oh, Tae-Su Jang, Minsoo Yoo, Yongtaik Kim, and Sungjoo Hong. Overcoming the Reliability Limitation in the Ultimately Scaled DRAM using Silicon Migration Technique by Hydrogen Annealing. In *IEDM*, 2017.
- [292] Donghyuk Yun, Myungsang Park, Chulseung Lim, and Sanghyeon Baeg. Study of T1D Effects on One Row Hammering using Gamma in DDR4 SDRAMs. In *IRPS*, 2018.
- [293] Chulseung Lim, Kyungbae Park, Geunyoung Bak, Donghyuk Yun, Myungsang Park, Sanghyeon Baeg, Shi-Jie Wen, and Richard Wong. Study of Proton Radiation Effect to Row Hammer Fault in DDR4 SDRAMs. *Microelectronics Reliability*, 2018.
- [294] Zhenrong Lang, Patrick Jattke, Michele Marazzi, and Kaveh Razavi. Blaster: Characterizing the blast radius of rowhammer. In *3rd Workshop on DRAM Security (DRAMSec) co-located with ISCA 2023*. ETH Zurich, 2023.
- [295] Hwayong Nam, Seungmin Baek, Minbok Wi, Michael Jaemin Kim, Jaehyun Park, Chihun Song, Nam Sung Kim, and Jung Ho Ahn. Dramscope: Uncovering DRAM Microarchitecture and Characteristics by Issuing Memory Commands. *ISCA*, 2024.
- [296] Ataberk Olgun, Majd Osseiran, Abdullah Giray Yaglıkci, Yahya Can Tuğrul, Haocong Luo, Steve Rhyner, Behzad Salami, Juan Gomez Luna, and Onur Mutlu. An Experimental Analysis of RowHammer in HBM2 DRAM Chips. In *DSN Disrupt*, 2023.
- [297] Hwayong Nam, Seungmin Baek, Minbok Wi, Michael Jaemin Kim, Jaehyun Park, Chihun Song, Nam Sung Kim, and Jung Ho Ahn. X-ray: Discovering DRAM Internal Structure and Error Characteristics by Issuing Memory Commands. *IEEE CAL*, 2023.
- [298] Haocong Luo, İsmail Emir Yüksel, Ataberk Olgun, A Giray Yağlıkcı, and Onur Mutlu. Revisiting DRAM Read Disturbance: Identifying Inconsistencies Between Experimental Characterization and Device-Level Studies. In *VTS*, 2025.
- [299] Wei He, Zhi Zhang, Yueqiang Cheng, Wenhao Wang, Wei Song, Yansong Gao, Qifei Zhang, Kang Li, Dongxi Liu, and Surya Nepal. WhistleBlower: A System-level Empirical Study on RowHammer. *IEEE Transactions on Computers*, 2023.
- [300] Haocong Luo, İsmail Emir Yüksel, Ataberk Olgun, A Giray Yağlıkcı, Mohammad Sadrosadati, and Onur Mutlu. An Experimental Characterization of Combined RowHammer and RowPress Read Disturbance in Modern DRAM Chips. In *DSN*

- Disrupt*, 2024.
- [301] Hasan Hassan, Yahya Can Tugrul, Jeremie S. Kim, Victor van der Veen, Kaveh Razavi, and Onur Mutlu. Uncovering in-DRAM RowHammer Protection Mechanisms: A New Methodology, Custom RowHammer Patterns, and Implications. In *MICRO*, 2021.
- [302] Pietro Frigo, Emanuele Vannacci, Hasan Hassan, Victor van der Veen, Onur Mutlu, Cristiano Giuffrida, Herbert Bos, and Kaveh Razavi. TRRespass: Exploiting the Many Sides of Target Row Refresh. In *S&P*, 2020.
- [303] Jikun Wang, Haocong Luo, Ataberk Olgun, Ismail Emir Yuksel, A. Giray Yaglikci, Yu Liang, F. Nisa Bostanci, Mohammad Sadrosadati, and Onur Mutlu. ScaleDisturb: Exploiting Temporal Asymmetry to Amplify Read Disturbance in Modern DRAM Chips. *DSN*, 2026.
- [304] Haocong Luo, Ismail Emir Yuksel, Ataberk Olgun, Nisa Bostanci, Orhun Ecemiş, Abdullah Giray Yağlıkçı, and Onur Mutlu. DejaVu: Why You Should Write to Your DRAM Rows Twice, Carefully. In *ISCA*, 2026.
- [305] JEDEC. *JESD79-5c: DDR5 SDRAM Standard*, 2024.
- [306] Onur Mutlu. Memory Scaling: A Systems Architecture Perspective. In *IMW*, 2013.
- [307] Y. Cai, S. Ghose, E. F. Haratsch, Y. Luo, and O. Mutlu. Error Characterization, Mitigation, and Recovery in Flash Memory Based Solid-State Drives. *Proc. IEEE*, 2017.
- [308] Onur Mutlu and Lavanya Subramanian. Research Problems and Opportunities in Memory Systems. *SUPERFRI*, 2014.
- [309] Onur Mutlu. Intelligent Architectures for Intelligent Computing Systems. In *DATE*, 2020.
- [310] Onur Mutlu. Retrospective: An Experimental Study of Data Retention Behavior in Modern DRAM Devices: Implications for Retention Time Profiling Mechanisms. Retrospective Issue for ISCA-50, 2023.
- [311] Onur Mutlu. Retrospective: RAIDR: Retention-Aware Intelligent DRAM Refresh. Retrospective Issue for ISCA-50, 2023.
- [312] Onur Mutlu. Retrospective: Flipping Bits in Memory Without Accessing Them: An Experimental Study of DRAM Disturbance Errors. Retrospective Issue for ISCA-50, 2023.
- [313] Junwhan Ahn, Sungpack Hong, Sungjoo Yoo, Onur Mutlu, and Kiyoun Choi. Retrospective: A Scalable Processing-in-memory Accelerator for Parallel Graph Processing. *arXiv*, 2023.
- [314] José F. Martínez, Engin Ipek, Onur Mutlu, and Rich Caruana. Retrospective: Self-optimizing Memory Controllers: A Reinforcement Learning Approach. Retrospective Issue for ISCA-50, 2023.
- [315] Haocong Luo, F. Nisa Bostanci, Ataberk Olgun, Maria Makeenkova, Ziad Malik, Ipek Akdeniz, and Onur Mutlu. Ramulator 2.1: A Composable Memory System Simulator for Modern DRAM Systems. The 3rd Tutorial on Ramulator and DRAM Bender colocated with ICS, 2026.
- [316] F. Nisa Bostanci, Haocong Luo, Ataberk Olgun, Maria Makeenkova, Geraldo F. de Oliveira, A. Giray Yağlıkçı, and Onur Mutlu. Extended Abstract: Re-Evaluating the Real-System Modeling Accuracy of Ramulator 2.0. The 3rd Tutorial on Ramulator and DRAM Bender colocated with ICS, 2026.
- [317] Ataberk Olgun, Haocong Luo, Ismail Emir Yuksel, F. Nisa Bostanci, A. Giray Yağlıkçı, and Onur Mutlu. A Modern Large-Scale Memory Characterization Laboratory. The 3rd Tutorial on Ramulator and DRAM Bender colocated with ICS, 2026.
- [318] Onur Mutlu, Justin Meza, and Lavanya Subramanian. The Main Memory System: Challenges and Opportunities. *Communications of the KIISE*, 2015.
- [319] Yu Cai, Saugata Ghose, Erich F Haratsch, Yixin Luo, and Onur Mutlu. Errors in Flash-Memory-Based Solid-State Drives: Analysis, Mitigation, and Recovery. *arXiv preprint arXiv:1711.11427*, 2017.
- [320] Juan Gómez-Luna, Jawad. El Hajj, Ivan Fernandez, and Christina Giannoula. Benchmarking a New Paradigm: Understanding a Modern Processing-in-Memory Architecture. In *SIGMETRICS*, 2021.
- [321] Andreas Kosmas Kakolyris, F. Nisa Bostanci, Ataberk Olgun, Ismail Emir Yuksel, Harsh Songara, Konstantinos Marios Sgouras, Umut Baser, Konstantinos Kanellopoulos, A. Giray Yaglikci, and Onur Mutlu. ColumnKeeper: Efficient Solutions for Mitigating ColumnDisturb in DRAM-based Systems. In *ISCA*, 2026.