How Should LLMs Listen While Speaking? A Study of User-Stream Routing in Full-Duplex Spoken Dialogue

Hui Lu^{1*}, Xueyuan Chen¹, Huimeng Wang¹, Shuhai Peng³,
Shiyin Kang^{2†}, Xixin Wu¹, Zhiyong Wu³

¹The Chinese University of Hong Kong, ²SenseTime Research, ³Tsinghua University
{luhui, xychen, huimengwang, wuxx, zywu}@se.cuhk.edu.hk
psh24@mails.tsinghua.edu.cn, kangshiyin@sensetime.com

Abstract

Full-duplex spoken dialogue requires a model to keep listening while generating its own spoken response. This is challenging for large language models (LLMs), which are designed to extend a single coherent sequence and do not naturally support user input arriving during generation. We argue that how the user stream is routed into the LLM is therefore a key architectural question for full-duplex modeling. To study this question, we extend a text-only LLM into a unified full-duplex spoken dialogue system and compare two routing strategies under a shared training pipeline: (i) channel fusion, which injects the user stream directly into the LLM input, and (ii) cross-attention routing, which keeps the user stream as external memory accessed through cross-attention adapters. Experiments on spoken question answering and full-duplex interaction benchmarks reveal a clear tradeoff. Channel fusion yields stronger semantic grounding and consistently better question-answering performance. However, under semantically overlapping conditions such as user interruptions, it is more vulnerable to context corruption: if the model fails to stop in time, the overlapping user stream can interfere with ongoing generation and lead to semantically incoherent continuations. Cross-attention routing underperforms on question answering, but better preserves the LLM generation context and is more robust to this failure mode. These results establish user-stream routing as a central design axis in full-duplex spoken dialogue and offer practical guidance on the tradeoff between semantic integration and context robustness. We provide a demo page³ for qualitative inspection.

1 Introduction

Speech is one of the most natural modalities for human communication, making spoken dialogue a key interface for human-machine interaction. Recent advances in large language models (LLMs) [45, 3] have made them an increasingly common foundation for spoken dialogue systems. Most existing spoken dialogue models adopt a strict turn-taking assumption. Under this formulation, the user and the system speak in alternation, without overlapping speech, so the interaction can be formulated into a single interleaved sequence of utterances. This corresponds to a half-duplex communication pattern, in which only one party is effectively transmitting information at a time. Many recent LLM-based spoken dialogue systems follow this setup: the model consumes the user’s complete speech utterance as input and then autoregressively generates a spoken response [6, 56, 10, 11, 25, 21, 43].

*Work done during an internship at SenseTime Research

†Corresponding author

³<https://light1726.github.io/duplex-demo/>

However, real-world spoken dialogue is often not strictly turn-based [40]. Speakers may interrupt one another or produce short backchannels while the other party is still speaking. In such cases, the two audio streams overlap in time. This is often referred to as the full-duplex spoken dialogue, where both parties can listen and speak simultaneously. Modeling full-duplex dialogue is important for more natural and fluid voice interaction, as highlighted by GPT-4o [35] and a growing body of recent work on full-duplex spoken dialogue systems [34, 7, 60, 46, 59, 19, 55].

Nevertheless, the dual-stream nature of full-duplex spoken dialogue is not naturally aligned with how LLMs are pre-trained. Standard LLMs are optimized to extend a single-stream token sequence through next-token prediction. In full-duplex dialogue, however, the model must continue generating its own response while also processing an external user speech stream to decide whether to keep generating, or stop speaking. This raises a central architectural question that prior work has largely addressed only implicitly: *how should the user stream be routed into the LLM during generation?* The answer is important because it determines how incoming user speech interacts with the model’s ongoing generation state, and therefore how robustly the model can behave under overlapping speech.

Existing full-duplex systems mainly address this question in two ways. The first is to segment both audio streams into fixed-size chunks and interleave them into a single-stream sequence [46, 5, 59, 55]. The LLM then models full-duplex dialogue as autoregressive prediction over this interleaved sequence. While conceptually simple, interleaving effectively doubles the sequence length and often inserts many silent user chunks, leading to additional KV-cache and computation overhead.

The second strategy is channel fusion, which combines the two streams at each time step before feeding them into the LLM [19, 54, 44]. Channel fusion is compact, since the sequence length remains the same as that of a single audio stream, and it gives the LLM direct, time-aligned access to the user stream at every step. However, once the two streams are fused, the model no longer has an explicit architectural mechanism to separate user input from its own generation context. This is particularly problematic when the two streams overlap in semantically meaningful ways, such as during user interruptions. If the model fails to stop promptly, the overlapping user speech may interfere with the context driving continued generation, leading to corrupted or semantically incoherent continuations. To our knowledge, this failure mode has not been systematically characterized in prior work.

Motivated by this limitation, we revisit a structurally separated alternative: routing the user stream through cross-attention adapters [1]. Under this design, the user stream is represented as an external memory of keys and values, while the LLM’s own generation remains in its native autoregressive context. This provides an explicit and gateable mechanism for attending to user speech without forcing it into the same context used for token generation. Although cross-attention adapters have been used for visual conditioning [1] and audio understanding [22], their role in full-duplex spoken dialogue, and their tradeoff relative to direct channel fusion, has not been systematically studied.

In this paper, we develop a unified framework for extending a text-only LLM into a full-duplex spoken dialogue model through task formulation, tailored data construction, and a staged training curriculum, including practical designs for user interruption handling. This framework provides a controlled testbed for studying user-stream routing as a central architectural design axis in full-duplex spoken dialogue. Within this shared setup, we compare two model variants under matched model and training conditions: **CF-Duplex**, which uses channel fusion, and **XA-Duplex**, which uses cross-attention routing. Our results reveal a clear tradeoff. **CF-Duplex** yields stronger spoken question answering performance, suggesting better semantic grounding from speech input. However, during user interruptions, the same direct conditioning can become a liability: when the model fails to stop in time, **CF-Duplex** is more prone to producing semantically incoherent continued generation, whereas **XA-Duplex** largely avoids this failure mode. We further examine this behavior through qualitative analysis of failed interruption cases, helping clarify when each routing strategy is preferable.

Our contributions are threefold: (i) we develop a unified framework for extending a text-only LLM into a full-duplex spoken dialogue model through task formulation, data construction, and a staged training curriculum, and introduce practical designs for user interruption handling; (ii) we identify user-stream routing as a key architectural design question in full-duplex spoken dialogue; and (iii) within a controlled experimental setting based on a shared system design and training curriculum, we compare channel fusion and cross-attention routing across automatic speech recognition (ASR), text-to-speech synthesis (TTS), turn-based spoken dialogue, and full-duplex spoken dialogue, revealing a tradeoff between stronger semantic integration and greater context robustness.

2 Related works

2.1 Speech-based LLMs and half-duplex spoken dialogue models

Recent work has increasingly adopted LLMs as a unified backbone for speech-language processing, including ASR, TTS, audio understanding, and spoken dialogue [57, 6, 56, 52, 25, 21, 22, 16, 15]. A common paradigm is to map speech into the LLM embedding space and represent speech and text as a single sequence that can be processed autoregressively. Recent systems further enable end-to-end spoken dialogue by generating both text and speech outputs within a unified framework [56, 10, 11, 42]. Despite their strong performance, these models typically assume strict turn taking: the system first consumes the user’s complete utterance and only then generates its response. As a result, they do not naturally support full-duplex behaviors such as interruption and backchannels handling. Our work builds on this line of speech-based LLMs, but extends it to full-duplex spoken dialogue through streaming speech processing adaptation, data construction, task design, and training.

2.2 Full-duplex spoken dialogue models

Full-duplex spoken dialogue can be supported either by coordinating an LLM with external modules such as voice activity or turn detection [58, 24, 50], or by adapting the LLM itself to model overlapping user and system speech end to end. While practical, external modules add latency and are not jointly optimized with the LLM. Recent end-to-end approaches mainly differ in how they represent and route the user and system streams during generation. One line of work interleaves the two streams into a single-stream sequence, as in SyncLLM [46], OmniFlatten [59], NTPP [48], and SALMONN-omni [55]. This yields a simple autoregressive formulation, but increases sequence length and often introduces many silent user chunks into the context. Another line adopts channel fusion, combining the user and system streams at each time step before entering the LLM, as in Moshi [7], LSLM [31], SLAM-duplex [19], FLM-Audio [54], and Fun-Audio-Chat [44]. Other architectures have also been explored, including dual decoders with cross-stream attention [34], dual-LLM designs [12], and encoder–decoder models that jointly encode both streams before decoding [32]. In contrast, our cross-attention variant keeps the user stream as a separate memory accessed during generation. To our knowledge, this form of separated user-stream routing has not been systematically compared with channel fusion under a shared modeling and training setup for full-duplex spoken dialogue.

2.3 LLMs with cross-attention conditioning

Cross-attention has been widely adopted in multimodal LLMs as a mechanism for conditioning a pretrained text-only LLM on external inputs. Flamingo [1] introduces cross-attention adapters for visual conditioning, and AudioFlamingo [22] extends this design to audio understanding. Related ideas have also been explored in streaming video understanding and reasoning, where cross-attention is used to route visual input into the LLM while preserving a separate textual generation context [29]. These works motivate cross-attention as a plausible mechanism for conditioning LLMs on external streaming input. However, its role in full-duplex spoken dialogue remains underexplored, particularly as a user-stream routing strategy to be compared directly with channel fusion.

3 Architecture

We extend a pretrained text-only LLM into a full-duplex spoken dialogue system with streaming speech input and output. The system comprises a streaming speech encoder and adapter for user audio, a text-only LLM backbone, an audio decoder for spoken response generation, and a user-stream routing module. We study two modeling variants, **CF-Duplex** and **XA-Duplex**, based on channel fusion and cross-attention routing strategies, respectively. Figure 1 illustrates the overall architecture. We describe the shared modules and the two routing variants in the following subsections.

3.1 Speech encoder and adapter

A full-duplex spoken dialogue system must process user audio incrementally so that it can decide, in real time, whether to continue listening, begin responding, or stop speaking. To this end, we initialize the speech encoder from pretrained Whisper [38] and adapt it for streaming speech processing. We

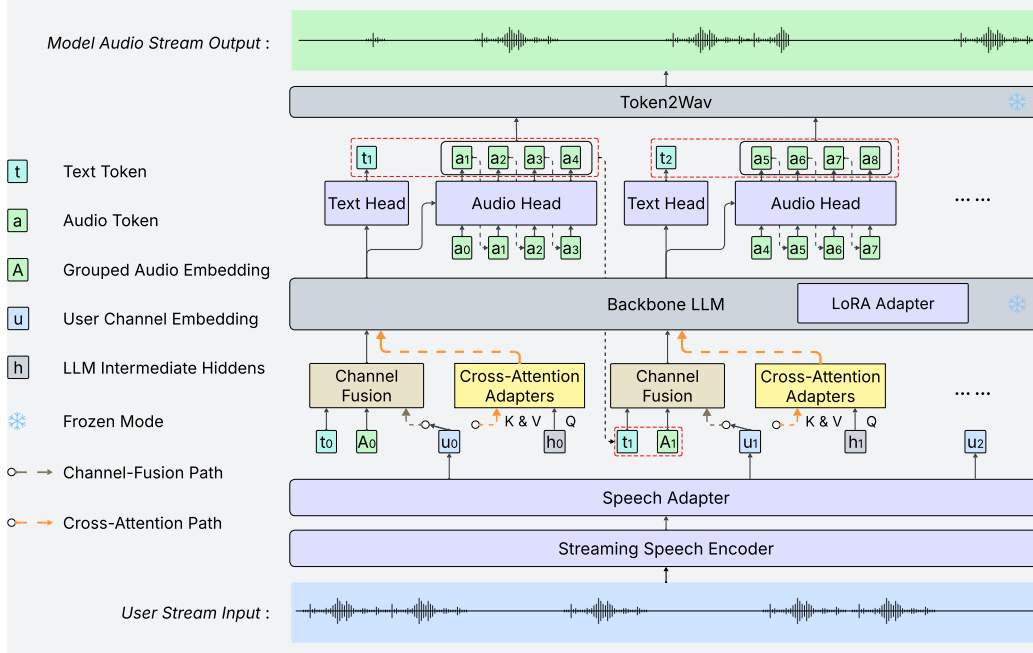

Figure 1: Model architecture

segment the input waveform into fixed-size chunks, extract mel-spectrogram features for each chunk independently, and feed the resulting spectrogram chunks to the encoder incrementally. During inference, the encoder maintains continuity across chunks using KV caching.

The original Whisper encoder consists of convolutional layers followed by bidirectional self-attention blocks. To preserve causality in streaming operation, we left-pad the convolutional input and apply causal masks to all self-attention layers. In addition, the original Whisper encoder uses sinusoidal positional embeddings, which are less suitable for long-form incremental processing. We therefore replace them with RoPE [41] and finetune them jointly with the adapted encoder.

We then apply a speech adapter to map the encoder output to the representation space expected by the backbone LLM. Specifically, the adapter consists of three linear layers, with the middle layer operating on pairs of consecutive frames concatenated along the feature dimension. This reduces the time resolution of the user stream by a factor of 2.

3.2 Speech tokenization and audio head

We use the supervised semantic speech tokenizer from CosyVoice 2 [9] to convert speech waveforms into discrete tokens at 25 Hz, and use the pretrained token2wav model from CosyVoice 2 for waveform reconstruction. On the output side, system speech is represented as discrete audio tokens and generated by an autoregressive audio decoder, which we refer to as the audio head. The audio head is implemented as a lightweight decoder LLM conditioned on last-layer hidden states from the backbone LLM. We choose this design instead of a shallow projection layer because mapping backbone representations to audio-token sequences is substantially more complex than standard text-token prediction. Because the audio-token sequence is much longer than the corresponding text-token sequence, we follow recent work [42, 44] and generate groups of \mathcal{G} consecutive audio tokens conditioned on the same backbone hidden state. This reduces the rate mismatch between text and audio generation. During decoding, each generated audio-token group is embedded and fed back into the backbone as the model-audio stream. To preserve a roughly causal relationship between text and speech generation, we introduce a delay factor \mathcal{D} , so that audio decoding starts only after \mathcal{D} text tokens have been generated. During training, we pad the shorter sequence at the end so that the text-token sequence and the audio-token-group sequence have the same length.

3.3 User-stream routing

We compare two strategies for routing the user stream into the backbone LLM: channel fusion and cross-attention routing, yielding two model variants, **CF-Duplex** and **XA-Duplex**, respectively. The user stream, model text stream, and model audio stream are defined on a shared duplex timeline, so aligned positions correspond to the same underlying interaction time step. For CF-Duplex, we directly fuse the user-stream embeddings with the model text and audio streams at each aligned time step, and the backbone LLM operates on the resulting sequence as a single autoregressive stream. Let the user stream, model text stream, and model audio stream be denoted by \mathbf{u} , \mathbf{m}_{text} , and $\mathbf{m}_{\text{audio}}$, respectively. Let $\mathbf{c} = [\mathbf{u}; \mathbf{m}_{\text{text}}; \mathbf{m}_{\text{audio}}]$ denote concatenation along the feature dimension. The fusion process is defined as

$$\mathbf{y} = \mathbf{u} + \mathbf{m}_{\text{text}} + \mathbf{m}_{\text{audio}} + \sigma(W_g \mathbf{c} + \mathbf{b}_g) \odot \text{MLP}(\mathbf{c}), \quad (1)$$

where σ is the element-wise sigmoid gate and MLP is a two-layer multilayer perceptron. This design gives the backbone LLM direct access to time-aligned user stream at every step, while also merging the user stream into the same context used for the system’s own generation.

For XA-Duplex, we keep the user stream as a separate memory and let the LLM access it through a set of cross-attention adapters. The user-stream embeddings serve as keys and values, while the intermediate hidden states of the backbone LLM serve as queries. We adopt the XA-Dense variant used in Flamingo [1] and AudioFlamingo [22]. To preserve temporal correspondence across streams, we assign the user stream the same timeline indices as the model streams and apply RoPE accordingly before feeding it into the cross-attention adapters. This allows intermediate LLM layers to attend to temporally aligned user evidence while keeping the user stream separate from the backbone LLM’s native autoregressive generation context.

4 Training strategy

To train the full-duplex spoken dialogue system, we use a staged curriculum spanning ASR, streaming TTS, speech-to-text dialogue (S2TD), speech-to-text-and-speech dialogue (S2TSD), and full-duplex spoken dialogue. We formulate all tasks using a unified stream-based format compatible with the target full-duplex setting, as illustrated in Figure 2. Each example is represented using a user stream, a model text stream, and, when applicable, a model audio stream.

4.1 Task formulation and sequence construction

We use special tokens to explicitly represent idle and interruption behavior along the duplex timeline. On the user side, $\langle \text{USER_WAIT} \rangle$ denotes intervals in which the user is silent while waiting for the system response. On the model side, $\langle \text{TEXT_WAIT} \rangle$ and $\langle \text{AUDIO_WAIT} \rangle$ denote intervals in which the model has not yet started responding or has finished responding and is waiting for further user input. For duplex dialogue, we additionally use $\langle \text{TEXT_INT} \rangle$ and $\langle \text{AUDIO_INT} \rangle$ to provide explicit supervision for interruption handling. We treat these special tokens as ordinary prediction targets in the corresponding streams, so that waiting and interruption behavior are learned through explicit token-level supervision. The details regarding how input and output sequences in different tasks are composed are described in Appendix B.

4.2 Training curriculum

We train both CF-Duplex and XA-Duplex using the same three-stage curriculum, progressing from basic speech perception and generation to turn-based dialogue and finally to full-duplex interaction. In Stage 1, we train the speech encoder, speech adapter, routing-specific modules, audio head, and LoRA adapters [18] of the backbone LLM on ASR and streaming TTS. In Stage 2, we freeze the speech encoder and backbone LLM and train the remaining modules on ASR, streaming TTS, S2TD, and S2TSD. In Stage 3, we train the same set of modules as in stage 2 on ASR, streaming TTS and full-duplex spoken dialogue, where the user input is a continuous audio stream containing silence, queries, interruptions, and backchanneling. Using the same curriculum for both variants helps isolate the effect of the routing design.

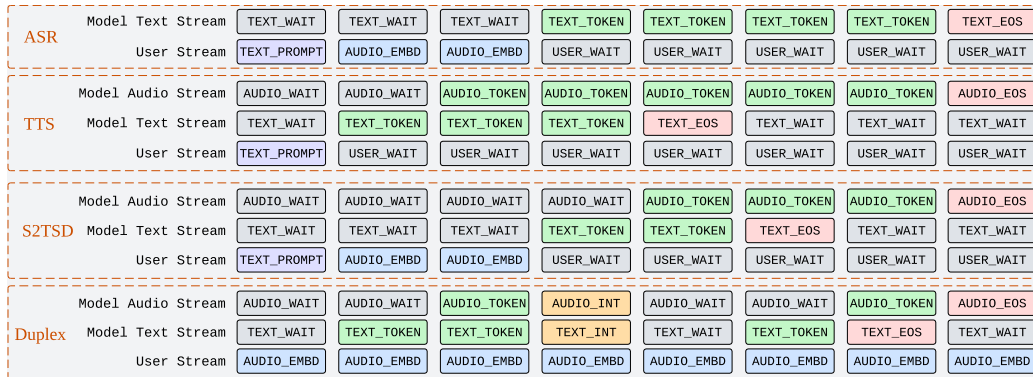

Figure 2: Input and output data formats for different tasks

5 Data preparation and construction

We prepare training data for ASR, TTS, turn-based spoken dialogue, and full-duplex spoken dialogue. Detailed dataset statistics, prompts, and construction examples are provided in the appendix C.

ASR and TTS data. For ASR, we combine several openly available English speech corpora, including LibriSpeech [36], GigaSpeech [4], PeopleSpeech [14], MLS [37], CommonVoice [2], VoxPopuli [47], and Emilia-Large [17], yielding 217k hours of English ASR data in total. For TTS, we use VoxBox [49], which provides 104k hours of English and Chinese speech synthesis data.

Turn-based spoken dialogue. To construct turn-based spoken dialogue data for S2TD and S2TSD training, we start from publicly available textual QA and dialogue datasets, including SQuAD [39], MS-MARCO [33], HotpotQA [53], Natural Questions [23], UltraChat [8], and I_Wonder_Why-Chinese⁴. We use Qwen3-30B-A3B-Instruct-2507⁵ to rewrite these samples into English spoken-style question-answer pairs and then synthesize them into speech using IndexTTS-2 [61]. We further filter out samples with overly long audio or poor text-audio consistency. After filtering, we obtain 1.9M turn-based spoken dialogue samples.

Full-duplex spoken dialogue. We construct full-duplex spoken dialogue by composing turn-based spoken dialogues into two-channel audio interactions. Based on these base conversations, we simulate two common full-duplex behaviors: user interruptions and backchanneling. For interruptions, we construct both context-dependent and context-independent cases. In the context-dependent case, we use Qwen3-30B-A3B-Instruct-2507 to generate a follow-up question triggered by a phrase in the initial response, and only allow the interruption to occur after that trigger phrase during the spoken dialogue construction. In the context-independent case, we insert a question-answer pair sampled from another conversation. For backchannels, we collect a list of user backchanneling words and append one into a base conversation. We construct full-duplex examples on the fly during training rather than pre-composing fixed two-channel conversations. This allows us to randomize insertion timing for interruptions and backchannels while enforcing semantic constraints for context-dependent interruptions. We also vary the model’s reaction delay to interruptions during training, which improves interruption handling in our ablations (see Section 6.4).

6 Experiments

6.1 Modeling and training configuration

We use Qwen3-1.7B⁶ as the backbone LLM and keep it frozen throughout training. We train LoRA adapters [18] on top of the backbone, with rank 16 and scaling factor $\alpha = 32$. The audio head is initialized from Qwen3-0.6B⁷. For speech generation, we set the audio grouping size to $\mathcal{G} = 4$ and

⁴https://huggingface.co/datasets/Mxode/I_Wonder_Why-Chinese

⁵<https://huggingface.co/Qwen/Qwen3-30B-A3B-Instruct-2507>

⁶<https://huggingface.co/Qwen/Qwen3-1.7B>

⁷<https://huggingface.co/Qwen/Qwen3-0.6B>

the delay factor to $\mathcal{D} = 2$. We find $\mathcal{G} = 4$ to work better than $\mathcal{G} = 5$ (which is adopted in [44]) in stage-1 training; the comparison is provided in Appendix F.1. For the XA-Duplex, we insert cross-attention layers into the even-numbered layers of the backbone LLM. We select this placement based on stage-1 ASR and TTS performance; details are provided in Appendix F.2. Other modeling and training specifications of our models can be found in Appendix D.

6.2 Metrics

We evaluate the proposed models on ASR, TTS, S2TD, S2TSD, and full-duplex spoken dialogue. For ASR, we report word error rate (WER) on LibriSpeech [36] `test-clean` and `test-other`. For TTS, we evaluate on `seed-tts-eval`⁸ and report WER on its English and Chinese subsets. For spoken question answering, we use LLaMA Questions (LLaMAQ)⁹, TriviaQA (TriviaQ) [20], WebQuestions (WebQ)¹⁰ and AlpacaEval [26], with audio questions from OpenAudioBench¹¹. Following the OpenAudioBench protocol, we use its evaluation prompts with GPT-5.4-mini¹² to judge answer correctness and quality for all four datasets. For S2TSD and full-duplex spoken dialogue, we evaluate both textual and spoken responses. For full-duplex interaction behavior, we report results on Full-Duplex-Bench v1.0 & v1.5 [28, 27]. On v1.0, we evaluate User Interruption and Smooth Turn Taking using takeover rate (TOR), response quality in GPT-4o score, and response latency. On v1.5, we evaluate User Interruption and User Backchannel using the benchmark-defined behavior scores, stop latency, and response latency. Detailed definitions are provided in Appendix E and can be referred to from the original papers.

6.3 Results

6.3.1 Question answering

We compare both CF-Duplex and XA-Duplex with representative half-duplex and full-duplex spoken dialogue models. Table 1 demonstrates that CF-Duplex achieves competitive question answering performance despite using a much smaller backbone LLM (Qwen3-1.7B) than most baselines. In particular, it remains comparable to prior full-duplex systems on LLaMAQ and TriviaQ, achieves the best spoken response quality on WebQ, and attains the best performance on AlpacaEval among all compared models. These results suggest that the proposed CF-Duplex can effectively support spoken dialogue understanding even under a compact model scale and training budget.

At the same time, Table 1 also reveals a clear gap between our two model variants: XA-Duplex consistently underperforms CF-Duplex across all four datasets in both speech and text responses. This indicates that, under the same backbone LLM, the CF-Duplex architecture provides substantially stronger QA capability than the XA-Duplex.

Table 1: Question answering performance (speech | text score)

Method	Backbone LLM	Full-Duplex	LLaMAQ	TriviaQ	WebQ	AlpacaEval
Speech-GPT [57]	LLaMA-13B	✗	- 21.0	- 14.8	- 6.5	-
GLM-4-Voice [56]	GLM-4-9B-Base	✗	50.7 64.7	26.5 39.1	15.9 32.2	3.58 3.82
Freeze-Omni [50]	Qwen2-7B-Instruct	✓	56.2 74.2	28.5 45.1	27.9 40.8	2.46 3.90
Moshi [7]	Helium (7B)	✓	54.5 60.8	16.7 25.6	22.1 23.4	1.76 1.84
SALM-Duplex [19]	TinyLlama-1.1B-chat	✓	51.3 -	16.9 -	25.0 -	2.99 -
CF-Duplex	Qwen3-1.7B	✓	50.7 57.3	18.1 19.6	28.0 30.3	3.94 4.16
XA-Duplex	Qwen3-1.7B	✓	38.3 40.3	8.0 8.2	18.4 18.7	3.87 4.04

6.3.2 Full-duplex behavior

We further evaluate interaction behavior on Full-Duplex Bench v1.0 and v1.5. As shown in Tables 2 and 3, CF-Duplex delivers the strongest overall performance among our model variants and

⁸<https://github.com/BytedanceSpeech/seed-tts-eval>

⁹<https://github.com/google-research-datasets/LLAMA1-Test-Set>

¹⁰https://huggingface.co/datasets/stanfordnlp/web_questions

¹¹<https://huggingface.co/datasets/baichuan-inc/OpenAudioBench>

¹²<https://openai.com/index/introducing-gpt-5-4-mini-and-nano/>

remains highly competitive with prior full-duplex systems. On Full-Duplex Bench v1.0, CF-Duplex achieves a perfect takeover rate in the User Interruption scenario (TOR = 1.000), matching the best reported result, while obtaining the highest response quality score (GPT-4o = 3.96). Although its interruption latency is slightly higher than that of the fastest systems, it remains low overall. In Smooth Turn Taking, CF-Duplex also attains strong performance, with high TOR and low latency, indicating reliable turn-end detection and prompt response generation.

Table 2: Results on Full-Duplex Bench v1.0

Models	User Interruption			Smooth Turn Taking	
	TOR (\uparrow)	GPT-4o (\uparrow)	Latency (\downarrow)	TOR (\uparrow)	Latency (\downarrow)
dGSLM [34]	0.917	0.201	2.531	0.975	0.352
Freeze-Omni [50]	0.867	3.615	1.409	0.336	0.953
Moshi [7]	1.000	0.765	0.257	0.941	0.265
Gemini Live [28]	0.891	3.376	1.183	0.655	1.301
CF-Duplex	1.000	3.96	0.374	0.924	0.336
XA-Duplex	0.971	2.23	0.325	0.983	0.161

On Full-Duplex Bench v1.5, CF-Duplex shows particularly strong control over user interruptions. In the Interruption scenario, it achieves the highest or tied-highest Respond score (0.72), while also obtaining the lowest stop latency (0.736 s) and the lowest respond latency (0.724 s) among all compared models. In the Backchannel scenario, it achieves the highest Resume rate (0.96). These results indicate that CF-Duplex can effectively tackle with user interruptions and backchannels.

In contrast, while XA-Duplex performs competitively on some timing-related metrics, such as backchannel response latency, and achieves the best result on Full-duplex v1.0 Smooth Turn-Taking, its overall behavior is less robust. We also observe that it sometimes responds too aggressively by talking over the user. In particular, it underperforms CF-Duplex on interruption handling, with substantially lower response quality on v1.0 and a much lower Respond score on v1.5. Overall, these results suggest that CF-Duplex provides a better balance between responsiveness, behavioral accuracy, and conversational quality.

Table 3: Results on Full-Duplex Bench v1.5

Task	Metric	Freeze-Omni [50]	Moshi [7]	CF-Duplex	XA-Duplex
Interruption	Respond (\uparrow)	0.72	0.50	0.72	0.32
	Resume (\downarrow)	0.12	0.26	0.17	0.41
	Uncertain (\downarrow)	0.03	0.00	0.04	0.05
	Unknown (\downarrow)	0.13	0.25	0.07	0.23
	Stop Latency (\downarrow)	1.42	1.16	0.74	1.18
	Respond Latency (\downarrow)	1.35	1.47	0.72	1.26
Backchannel	Respond (\downarrow)	0.07	0.02	0.02	0.05
	Resume (\uparrow)	0.80	0.06	0.96	0.86
	Uncertain (\downarrow)	0.02	0.00	0.02	0.00
	Unknown (\downarrow)	0.11	0.92	0.00	0.09
	Stop Latency (\uparrow)	0.66	0.42	0.60	0.62
	Respond Latency (\downarrow)	2.16	3.00	2.08	1.67

6.3.3 Generation Coherence Under Missed Interruptions

We further analyze a specific failure mode in the User Interruption setting. We test with cases in which the model fails to yield the floor when user interrupts. We collect such cases for both CF-Duplex and XA-Duplex. Within this filtered subset, we observe a clear qualitative difference between the two variants. When CF-Duplex misses the interruption, its continued generation often becomes semantically incoherent, apparently blending content from the user interruption with its own ongoing response. In contrast, when XA-Duplex misses the interruption, it typically continues its original response coherently, although it still fails to yield the floor. This suggests that the XA-Duplex routing strategy has better potential to maintain generation coherence under overlapping speech. We demonstrate some sample pairs from CF-Duplex and XA-Duplex in Appendix G.

Table 4: Task performance across training stages. L, T, W denote LLaMA Questions, Trivia Questions and Web Questions, respectively

Stage	Model	ASR	TTS	S2TD (text score)			S2TSD (speech text score)		
		(Clean Other)	(EN ZH)	L	T	W	L	T	W
-	Whisper-large-v3	2.01 3.91	-	-	-	-	-	-	-
-	CosyVoice 2 [9]	-	2.57 1.45	-	-	-	-	-	-
-	OmniFlatten [59]	7.91 19.21	-	-	-	-	-	-	-
-	Mini-Omni2 [51]	4.80 9.80	-	-	-	-	-	-	-
-	VITA-1.5 [13]	3.40 7.50	-	-	-	-	-	-	-
-	SpeechGPT [57]	-	-	21.6	14.8	6.5	-	-	-
-	LLaMA-Omni2-1.5B [11]	-	-	-	-	-	52.7 62.0	-	26.6 28.2
-	GLM-4-Voice [56]	2.82 7.66	2.91 2.10	-	-	-	50.7 64.7	26.5 39.1	15.9 32.2
1	CF-Duplex	2.90 8.17	2.37 2.13	-	-	-	-	-	-
	XA-Duplex	4.12 11.73	2.40 2.21	-	-	-	-	-	-
2	CF-Duplex	3.50 9.50	2.41 3.13	61.3	24.2	33.1	53.7 57.7	20.9 21.3	30.5 31.2
	XA-Duplex	4.56 12.38	2.29 2.88	45.3	13.6	23.3	39.6 44.0	9.7 10.3	21.9 22.6
3	CF-Duplex	3.90 10.04	2.93 3.37	-	-	-	-	-	-
	XA-Duplex	4.56 12.49	2.83 3.20	-	-	-	-	-	-

6.3.4 Intermediate training stage performance

Table 4 compares CF-Duplex and XA-Duplex across the three training stages. In Stage 1, where the models are trained only on the ASR and TTS tasks, CF-Duplex already shows stronger speech recognition performance and TTS quality than XA-Duplex. In Stage 2, after introducing spoken dialogue training, the gap between the two variants becomes clear: CF-Duplex consistently outperforms XA-Duplex on both S2TD and S2TSD across three QA datasets, indicating substantially better semantic grounding from speech inputs. In Stage 3, after full-duplex fine-tuning, both variants exhibit some degradation on the base ASR/TTS tasks, reflecting the trade-off introduced by broader conversational training. Nevertheless, CF-Duplex continues to retain a clear advantage on spoken dialogue performance, remaining substantially stronger than XA-Duplex on all duplex QA benchmarks (Table 1). Overall, these results show that the performance gap between the two routing strategies emerges as soon as dialogue capability is introduced and persists through full-duplex training, highlighting the effectiveness of channel fusion for preserving and leveraging semantic information in full-duplex spoken dialogue modeling.

6.4 Ablation studies

We ablate two design choices for user interruption handling with CF-Duplex: explicit interruption token prediction (i.e., <AUDIO_INT> and <TEXT_INT>) and the use of a dynamic interruption overlap range during duplex training. Table 5 shows that both improve interruption handling. Removing <AUDIO_INT> and <TEXT_INT> supervision substantially lowers the Respond score and increases both stop and respond latencies, indicating weaker interruption detection and slower turn yielding. Using a fixed overlap duration also performs worse than the dynamic range [2, 6], where the model is trained to yield after waiting 2 to 6 text tokens or audio token groups (or 320 to 960 ms) with probability distribution [0.6, 0.3, 0.06, 0.03, 0.01]. This suggests that exposure to varied interruption overlap ranges improves robustness. The best overall performance is achieved by combining explicit interruption tokens with a dynamic overlap range.

Table 5: Ablation of explicit interruption token prediction and interruption overlap range in CF-Duplex training, evaluated on the User Interruption setting of Full-Duplex Bench v1.5

Interrupt Tokens	Overlap Range	Respond (↑)	Resume (↓)	Uncertain (↓)	Unknown (↓)	Stop Latency (↓)	Respond Latency (↓)
✓	[2, 6]	0.72	0.17	0.04	0.07	0.74	0.72
✗	[2, 6]	0.56	0.28	0.04	0.12	1.90	1.51
✓	2	0.58	0.3	0.03	0.09	1.11	1.07
✓	3	0.67	0.24	0.03	0.07	0.73	0.80

7 Conclusion

We study full-duplex spoken dialogue through the lens of user-stream routing, i.e., how incoming user speech is incorporated into an LLM during ongoing generation. To enable a controlled comparison, we develop a unified framework for extending a text-only LLM to full-duplex spoken dialogue with staged training and explicit supervision for interruption handling. Within this framework, we compare two model variants under matched settings: **CF-Duplex**, which uses channel fusion, and **XA-Duplex**, which uses cross-attention routing. Our results show a clear tradeoff: **CF-Duplex** yields stronger spoken question-answering performance, while **XA-Duplex** is more robust to user speech overlap and better avoids semantically incoherent continued generation. These findings identify user-stream routing as a key architectural design axis for full-duplex spoken dialogue. We discuss broader societal impacts of this work in Appendix A.

8 Limitations

Our study has several limitations. We consider only two routing strategies of the user stream within a single framework, and other designs may exhibit different tradeoffs. In addition, all experiments are conducted at a single model scale with a fixed backbone and training recipe. Due to limited compute resources, we are not able to perform larger-scale experiments, so it remains unclear how the observed tradeoffs evolve with model scale or broader architectural exploration.

References

- [1] Jean-Baptiste Alayrac, Jeff Donahue, Pauline Luc, Antoine Miech, Iain Barr, Yana Hasson, Karel Lenc, Arthur Mensch, Katherine Millican, Malcolm Reynolds, Roman Ring, Eliza Rutherford, Serkan Cabi, Tengda Han, Zhitao Gong, Sina Samangooei, Marianne Monteiro, Jacob L. Menick, Sebastian Borgeaud, Andy Brock, Aida Nematzadeh, Sahand Sharifzadeh, Mikolaj Binkowski, Ricardo Barreira, Oriol Vinyals, Andrew Zisserman, and Karén Simonyan. Flamingo: a visual language model for few-shot learning. In Sanmi Koyejo, S. Mohamed, A. Agarwal, Danielle Belgrave, K. Cho, and A. Oh, editors, *Advances in Neural Information Processing Systems 35: Annual Conference on Neural Information Processing Systems 2022, NeurIPS 2022, New Orleans, LA, USA, November 28 - December 9, 2022*, 2022.
- [2] Rosana Ardila, Megan Branson, Kelly Davis, Michael Kohler, Josh Meyer, Michael Henretty, Reuben Morais, Lindsay Saunders, Francis Tyers, and Gregor Weber. Common voice: A massively-multilingual speech corpus. In Nicoletta Calzolari, Frédéric B chet, Philippe Blache, Khalid Choukri, Christopher Cieri, Thierry Declerck, Sara Goggi, Hitoshi Isahara, Bente Maegaard, Joseph Mariani, H l ne Mazo, Asuncion Moreno, Jan Odijk, and Stelios Piperidis, editors, *Proceedings of the Twelfth Language Resources and Evaluation Conference*, pages 4218–4222, Marseille, France, May 2020. European Language Resources Association.
- [3] Tom Brown, Benjamin Mann, Nick Ryder, Melanie Subbiah, Jared D Kaplan, Prafulla Dhariwal, Arvind Neelakantan, Pranav Shyam, Girish Sastry, Amanda Askell, Sandhini Agarwal, Ariel Herbert-Voss, Gretchen Krueger, Tom Henighan, Rewon Child, Aditya Ramesh, Daniel Ziegler, Jeffrey Wu, Clemens Winter, Chris Hesse, Mark Chen, Eric Sigler, Mateusz Litwin, Scott Gray, Benjamin Chess, Jack Clark, Christopher Berner, Sam McCandlish, Alec Radford, Ilya Sutskever, and Dario Amodei. Language models are few-shot learners. In H. Larochelle, M. Ranzato, R. Hadsell, M.F. Balcan, and H. Lin, editors, *Advances in Neural Information Processing Systems*, volume 33, pages 1877–1901. Curran Associates, Inc., 2020.
- [4] Guoguo Chen, Shuzhou Chai, Guan-Bo Wang, Jiayu Du, Wei-Qiang Zhang, Chao Weng, Dan Su, Daniel Povey, Jan Trmal, Junbo Zhang, Mingjie Jin, Sanjeev Khudanpur, Shinji Watanabe, Shuaijiang Zhao, Wei Zou, Xiangang Li, Xuchen Yao, Yongqing Wang, Zhao You, and Zhiyong Yan. Gigaspeech: An evolving, multi-domain ASR corpus with 10, 000 hours of transcribed audio. In Hynek Hermansky, Honza Cernock y, Luk s Burget, Lori Lamel, Odette Scharenborg, and Petr Motl cek, editors, *22nd Annual Conference of the International Speech Communication Association, Interspeech 2021, Brno, Czechia, August 30 - September 3, 2021*, pages 3670–3674. ISCA, 2021.

- [5] Qian Chen, Yafeng Chen, Yanni Chen, Mengzhe Chen, Yingda Chen, Chong Deng, Zhihao Du, Ruize Gao, Changfeng Gao, Zhifu Gao, Yabin Li, Xiang Lv, Jiaqing Liu, Haoneng Luo, Bin Ma, Chongjia Ni, Xian Shi, Jialong Tang, Hui Wang, Hao Wang, Wen Wang, Yuxuan Wang, Yunlan Xu, Fan Yu, Zhijie Yan, Yexin Yang, Baosong Yang, Xian Yang, Guanrou Yang, Tianyu Zhao, Qinglin Zhang, Shiliang Zhang, Nan Zhao, Pei Zhang, Chong Zhang, and Jinren Zhou. Minmo: A multimodal large language model for seamless voice interaction. *CoRR*, abs/2501.06282, 2025.
- [6] Yunfei Chu, Jin Xu, Qian Yang, Haojie Wei, Xipin Wei, Zhifang Guo, Yichong Leng, Yuanjun Lv, Jinzheng He, Junyang Lin, Chang Zhou, and Jingren Zhou. Qwen2-audio technical report. *CoRR*, abs/2407.10759, 2024.
- [7] Alexandre Défossez, Laurent Mazaré, Manu Orsini, Amélie Royer, Patrick Pérez, Hervé Jégou, Edouard Grave, and Neil Zeghidour. Moshi: a speech-text foundation model for real-time dialogue. *CoRR*, abs/2410.00037, 2024.
- [8] Ning Ding, Yulin Chen, Bokai Xu, Yujia Qin, Shengding Hu, Zhiyuan Liu, Maosong Sun, and Bowen Zhou. Enhancing chat language models by scaling high-quality instructional conversations. In Houda Bouamor, Juan Pino, and Kalika Bali, editors, *Proceedings of the 2023 Conference on Empirical Methods in Natural Language Processing*, pages 3029–3051, Singapore, December 2023. Association for Computational Linguistics.
- [9] Zhihao Du, Yuxuan Wang, Qian Chen, Xian Shi, Xiang Lv, Tianyu Zhao, Zhifu Gao, Yexin Yang, Changfeng Gao, Hui Wang, Fan Yu, Huadai Liu, Zhengyan Sheng, Yue Gu, Chong Deng, Wen Wang, Shiliang Zhang, Zhijie Yan, and Jingren Zhou. Cosyvoice 2: Scalable streaming speech synthesis with large language models. *CoRR*, abs/2412.10117, 2024.
- [10] Qingkai Fang, Shoutao Guo, Yan Zhou, Zhengrui Ma, Shaolei Zhang, and Yang Feng. Llama-omni: Seamless speech interaction with large language models. In *The Thirteenth International Conference on Learning Representations, ICLR 2025, Singapore, April 24-28, 2025*. OpenReview.net, 2025.
- [11] Qingkai Fang, Yan Zhou, Shoutao Guo, Shaolei Zhang, and Yang Feng. LLaMA-omni 2: LLM-based real-time spoken chatbot with autoregressive streaming speech synthesis. In Wanxiang Che, Joyce Nabende, Ekaterina Shutova, and Mohammad Taher Pilehvar, editors, *Proceedings of the 63rd Annual Meeting of the Association for Computational Linguistics (Volume 1: Long Papers)*, pages 18617–18629, Vienna, Austria, July 2025. Association for Computational Linguistics.
- [12] Chaoyou Fu, Haojia Lin, Zuwei Long, Yunhang Shen, Meng Zhao, Yifan Zhang, Xiong Wang, Di Yin, Long Ma, Xiawu Zheng, Ran He, Rongrong Ji, Yunsheng Wu, Caifeng Shan, and Xing Sun. VITA: towards open-source interactive omni multimodal LLM. *CoRR*, abs/2408.05211, 2024.
- [13] Chaoyou Fu, Haojia Lin, Xiong Wang, Yifan Zhang, Yunhang Shen, Xiaoyu Liu, Haoyu Cao, Zuwei Long, Heting Gao, Ke Li, Long Ma, Xiawu Zheng, Rongrong Ji, Xing Sun, Caifeng Shan, and Ran He. VITA-1.5: towards gpt-4o level real-time vision and speech interaction. *CoRR*, abs/2501.01957, 2025.
- [14] Daniel Galvez, Greg Diamos, Juan Torres, Keith Achorn, Juan Cerón, Anjali Gopi, David Kanter, Max Lam, Mark Mazumder, and Vijay Janapa Reddi. The people’s speech: A large-scale diverse english speech recognition dataset for commercial usage. In J. Vanschoren and S. Yeung, editors, *Proceedings of the Neural Information Processing Systems Track on Datasets and Benchmarks*, volume 1, 2021.
- [15] Sreyan Ghosh, Arushi Goel, Jaehyeon Kim, Sonal Kumar, Zhifeng Kong, Sang gil Lee, Chao-Han Huck Yang, Ramani Duraiswami, Dinesh Manocha, Rafael Valle, and Bryan Catanzaro. Audio flamingo 3: Advancing audio intelligence with fully open large audio language models. In *The Thirty-ninth Annual Conference on Neural Information Processing Systems*, 2026.
- [16] Sreyan Ghosh, Zhifeng Kong, Sonal Kumar, S Sakshi, Jaehyeon Kim, Wei Ping, Rafael Valle, Dinesh Manocha, and Bryan Catanzaro. Audio flamingo 2: An audio-language model with long-audio understanding and expert reasoning abilities. In *Forty-second International Conference on Machine Learning*, 2025.

- [17] Haorui He, Zengqiang Shang, Chaoren Wang, Xuyuan Li, Yicheng Gu, Hua Hua, Liwei Liu, Chen Yang, Jiaqi Li, Peiyang Shi, Yuancheng Wang, Kai Chen, Pengyuan Zhang, and Zhizheng Wu. Emilia: A large-scale, extensive, multilingual, and diverse dataset for speech generation. *CoRR*, abs/2501.15907, 2025.
- [18] Edward J. Hu, Yelong Shen, Phillip Wallis, Zeyuan Allen-Zhu, Yuanzhi Li, Shean Wang, Lu Wang, and Weizhu Chen. Lora: Low-rank adaptation of large language models. In *The Tenth International Conference on Learning Representations, ICLR 2022, Virtual Event, April 25-29, 2022*. OpenReview.net, 2022.
- [19] Ke Hu, Ehsan Hosseini-Asl, Chen Chen, Edresson Casanova, Subhankar Ghosh, Piotr Zelasko, Zhehuai Chen, Jason Li, Jagadeesh Balam, and Boris Ginsburg. Efficient and direct duplex modeling for speech-to-speech language model. In Odette Scharenborg, Catharine Oertel, and Khiet Truong, editors, *26th Annual Conference of the International Speech Communication Association, Interspeech 2025, Rotterdam, The Netherlands, 17-21 August 2025*. ISCA, 2025.
- [20] Mandar Joshi, Eunsol Choi, Daniel S. Weld, and Luke Zettlemoyer. Triviaqa: A large scale distantly supervised challenge dataset for reading comprehension. In Regina Barzilay and Min-Yen Kan, editors, *Proceedings of the 55th Annual Meeting of the Association for Computational Linguistics, ACL 2017, Vancouver, Canada, July 30 - August 4, Volume 1: Long Papers*, pages 1601–1611. Association for Computational Linguistics, 2017.
- [21] KimiTeam, Ding Ding, Zeqian Ju, Yichong Leng, Songxiang Liu, Tong Liu, Zeyu Shang, Kai Shen, Wei Song, Xu Tan, Heyi Tang, Zhengtao Wang, Chu Wei, Yifei Xin, Xinran Xu, Jianwei Yu, Yutao Zhang, Xinyu Zhou, Y. Charles, Jun Chen, Yanru Chen, Yulun Du, Weiran He, Zhenxing Hu, Guokun Lai, Qingcheng Li, Yangyang Liu, Weidong Sun, Jianzhou Wang, Yuzhi Wang, Yuefeng Wu, Yuxin Wu, Dongchao Yang, Hao Yang, Ying Yang, Zhilin Yang, Aoxiong Yin, Ruibin Yuan, Yutong Zhang, and Zaida Zhou. Kimi-audio technical report. *CoRR*, abs/2504.18425, 2025.
- [22] Zhifeng Kong, Arushi Goel, Rohan Badlani, Wei Ping, Rafael Valle, and Bryan Catanzaro. Audio flamingo: A novel audio language model with few-shot learning and dialogue abilities. In Ruslan Salakhutdinov, Zico Kolter, Katherine A. Heller, Adrian Weller, Nuria Oliver, Jonathan Scarlett, and Felix Berkenkamp, editors, *Forty-first International Conference on Machine Learning, ICML 2024, Vienna, Austria, July 21-27, 2024*, Proceedings of Machine Learning Research, pages 25125–25148. PMLR / OpenReview.net, 2024.
- [23] Tom Kwiatkowski, Jennimaria Palomaki, Olivia Redfield, Michael Collins, Ankur Parikh, Chris Alberti, Danielle Epstein, Illia Polosukhin, Jacob Devlin, Kenton Lee, Kristina Toutanova, Llion Jones, Matthew Kelcey, Ming-Wei Chang, Andrew M. Dai, Jakob Uszkoreit, Quoc Le, and Slav Petrov. Natural questions: A benchmark for question answering research. *Transactions of the Association for Computational Linguistics*, 7:452–466, 2019.
- [24] Guojian Li, Chengyou Wang, Hongfei Xue, Shuiyuan Wang, Dehui Gao, Zihan Zhang, Yuke Lin, Wenjie Li, Longshuai Xiao, Zhonghua Fu, and Lei Xie. Easy turn: Integrating acoustic and linguistic modalities for robust turn-taking in full-duplex spoken dialogue systems. *CoRR*, abs/2509.23938, 2025.
- [25] Tianpeng Li, Jun Liu, Tao Zhang, Yuanbo Fang, Da Pan, Mingrui Wang, Zheng Liang, Zehuan Li, Mingan Lin, Guosheng Dong, Jianhua Xu, Haoze Sun, Zenan Zhou, and Weipeng Chen. Baichuan-audio: A unified framework for end-to-end speech interaction. *CoRR*, abs/2502.17239, 2025.
- [26] Xuechen Li, Tianyi Zhang, Yann Dubois, Rohan Taori, Ishaan Gulrajani, Carlos Guestrin, Percy Liang, and Tatsunori B. Hashimoto. AlpacaEval: An automatic evaluator of instruction-following models. https://github.com/tatsu-lab/alpaca_eval, 5 2023.
- [27] Guan-Ting Lin, Shih-Yun Shan Kuan, Qirui Wang, Jiachen Lian, Tingle Li, and Hung-yi Lee. Full-duplex-bench v1. 5: Evaluating overlap handling for full-duplex speech models. *arXiv preprint arXiv:2507.23159*, 2025.

- [28] Guan-Ting Lin, Jiachen Lian, Tingle Li, Qirui Wang, Gopala Anumanchipalli, Alexander H. Liu, and Hung-Yi Lee. Full-duplex-bench: A benchmark to evaluate full-duplex spoken dialogue models on turn-taking capabilities. In *IEEE Automatic Speech Recognition and Understanding Workshop, ASRU 2025, Honolulu, HI, USA, December 6-10, 2025*, pages 1–8. IEEE, 2025.
- [29] Jihao Liu, Zhiding Yu, Shiyi Lan, Shihao Wang, Rongyao Fang, Jan Kautz, Hongsheng Li, and José M. Álvarez. Streamchat: Chatting with streaming video. *CoRR*, abs/2412.08646, 2024.
- [30] Ilya Loshchilov and Frank Hutter. Decoupled weight decay regularization. In *7th International Conference on Learning Representations, ICLR 2019, New Orleans, LA, USA, May 6-9, 2019*. OpenReview.net, 2019.
- [31] Ziyang Ma, Yakun Song, Chenpeng Du, Jian Cong, Zhuo Chen, Yuping Wang, Yuxuan Wang, and Xie Chen. Language model can listen while speaking. In *Proceedings of the Thirty-Ninth AAAI Conference on Artificial Intelligence and Thirty-Seventh Conference on Innovative Applications of Artificial Intelligence and Fifteenth Symposium on Educational Advances in Artificial Intelligence, AAAI’25/IAAI’25/EAAI’25*. AAAI Press, 2025.
- [32] Long Mai and Julie Carson-Berndsen. Real-time textless dialogue generation. *CoRR*, abs/2501.04877, 2025.
- [33] Tri Nguyen, Mir Rosenberg, Xia Song, Jianfeng Gao, Saurabh Tiwary, Rangan Majumder, and Li Deng. MS MARCO: A human generated machine reading comprehension dataset. In Tarek Richard Besold, Antoine Bordes, Artur S. d’Avila Garcez, and Greg Wayne, editors, *Proceedings of the Workshop on Cognitive Computation: Integrating neural and symbolic approaches 2016 co-located with the 30th Annual Conference on Neural Information Processing Systems (NIPS 2016), Barcelona, Spain, December 9, 2016*, CEUR Workshop Proceedings. CEUR-WS.org, 2016.
- [34] Tu Anh Nguyen, Eugene Kharitonov, Jade Copet, Yossi Adi, Wei-Ning Hsu, Ali Elkahky, Paden Tomasello, Robin Algayres, Benoît Sagot, Abdelrahman Mohamed, and Emmanuel Dupoux. Generative spoken dialogue language modeling. *Trans. Assoc. Comput. Linguistics*, 11:250–266, 2023.
- [35] OpenAI. Gpt-4o system card. *CoRR*, abs/2410.21276, 2024.
- [36] Vassil Panayotov, Guoguo Chen, Daniel Povey, and Sanjeev Khudanpur. Librispeech: An ASR corpus based on public domain audio books. In *2015 IEEE International Conference on Acoustics, Speech and Signal Processing, ICASSP 2015, South Brisbane, Queensland, Australia, April 19-24, 2015*, pages 5206–5210. IEEE, 2015.
- [37] Vineel Pratap, Qiantong Xu, Anuroop Sriram, Gabriel Synnaeve, and Ronan Collobert. MLS: A large-scale multilingual dataset for speech research. In Helen Meng, Bo Xu, and Thomas Fang Zheng, editors, *21st Annual Conference of the International Speech Communication Association, Interspeech 2020, Virtual Event, Shanghai, China, October 25-29, 2020*, pages 2757–2761. ISCA, 2020.
- [38] Alec Radford, Jong Wook Kim, Tao Xu, Greg Brockman, Christine McLeavey, and Ilya Sutskever. Robust speech recognition via large-scale weak supervision. In Andreas Krause, Emma Brunskill, Kyunghyun Cho, Barbara Engelhardt, Sivan Sabato, and Jonathan Scarlett, editors, *International Conference on Machine Learning, ICML 2023, 23-29 July 2023, Honolulu, Hawaii, USA*, Proceedings of Machine Learning Research, pages 28492–28518. PMLR, 2023.
- [39] Pranav Rajpurkar, Jian Zhang, Konstantin Lopyrev, and Percy Liang. SQuAD: 100,000+ questions for machine comprehension of text. In Jian Su, Kevin Duh, and Xavier Carreras, editors, *Proceedings of the 2016 Conference on Empirical Methods in Natural Language Processing*, pages 2383–2392, Austin, Texas, November 2016. Association for Computational Linguistics.
- [40] Emanuel A. Schegloff. Overlapping talk and the organization of turn-taking for conversation. *Language in Society*, 29(1):1–63, 2000.

- [41] Jianlin Su, Murtadha H. M. Ahmed, Yu Lu, Shengfeng Pan, Wen Bo, and Yunfeng Liu. Ro-former: Enhanced transformer with rotary position embedding. *Neurocomputing*, 568:127063, 2024.
- [42] Chao-Hong Tan, Qian Chen, Wen Wang, Chong Deng, Qinglin Zhang, Luyao Cheng, Hai Yu, Xin Zhang, Xiang Lyu, Tianyu Zhao, Chong Zhang, Yukun Ma, Yafeng Chen, Hui Wang, Jiaqing Liu, Xiangang Li, and Jieping Ye. Drvoice: Parallel speech-text voice conversation model via dual-resolution speech representations. In *The Fourteenth International Conference on Learning Representations*, 2026.
- [43] StepFun Audio Team. Step-audio 2 technical report. *CoRR*, abs/2507.16632, 2025.
- [44] Tongyi Fun Team, Qian Chen, Luyao Cheng, Chong Deng, Xiangang Li, Jiaqing Liu, Chao-Hong Tan, Wen Wang, Junhao Xu, Jieping Ye, Qinglin Zhang, Qiquan Zhang, and Jingren Zhou. Fun-audio-chat technical report. *CoRR*, abs/2512.20156, 2025.
- [45] Ashish Vaswani, Noam Shazeer, Niki Parmar, Jakob Uszkoreit, Llion Jones, Aidan N. Gomez, Lukasz Kaiser, and Illia Polosukhin. Attention is all you need. In Isabelle Guyon, Ulrike von Luxburg, Samy Bengio, Hanna M. Wallach, Rob Fergus, S. V. N. Vishwanathan, and Roman Garnett, editors, *Advances in Neural Information Processing Systems 30: Annual Conference on Neural Information Processing Systems 2017, December 4-9, 2017, Long Beach, CA, USA*, pages 5998–6008, 2017.
- [46] Bandhav Veluri, Benjamin N Peloquin, Bokai Yu, Hongyu Gong, and Shyamnath Gollakota. Beyond turn-based interfaces: Synchronous LLMs as full-duplex dialogue agents. In Yaser Al-Onaizan, Mohit Bansal, and Yun-Nung Chen, editors, *Proceedings of the 2024 Conference on Empirical Methods in Natural Language Processing*, pages 21390–21402, Miami, Florida, USA, November 2024. Association for Computational Linguistics.
- [47] Changhan Wang, Morgane Riviere, Ann Lee, Anne Wu, Chaitanya Talnikar, Daniel Haziza, Mary Williamson, Juan Pino, and Emmanuel Dupoux. VoxPopuli: A large-scale multilingual speech corpus for representation learning, semi-supervised learning and interpretation. In Chengqing Zong, Fei Xia, Wenjie Li, and Roberto Navigli, editors, *Proceedings of the 59th Annual Meeting of the Association for Computational Linguistics and the 11th International Joint Conference on Natural Language Processing (Volume 1: Long Papers)*, pages 993–1003, Online, August 2021. Association for Computational Linguistics.
- [48] Qichao Wang, Ziqiao Meng, Wenqian Cui, Yifei Zhang, Pengcheng Wu, Bingzhe Wu, Irwin King, Liang Chen, and Peilin Zhao. NTPP: generative speech language modeling for dual-channel spoken dialogue via next-token-pair prediction. In Aarti Singh, Maryam Fazel, Daniel Hsu, Simon Lacoste-Julien, Felix Berkenkamp, Tegan Maharaj, Kiri Wagstaff, and Jerry Zhu, editors, *Forty-second International Conference on Machine Learning, ICML 2025, Vancouver, BC, Canada, July 13-19, 2025*, Proceedings of Machine Learning Research. PMLR / OpenReview.net, 2025.
- [49] Xinsheng Wang, Mingqi Jiang, Ziyang Ma, Ziyu Zhang, Songxiang Liu, Linqin Li, Zheng Liang, Qixi Zheng, Rui Wang, Xiaoqin Feng, Weizhen Bian, Zhen Ye, Sitong Cheng, Ruibin Yuan, Zhixian Zhao, Xinfa Zhu, Jiahao Pan, Liumeng Xue, Pengcheng Zhu, Yunlin Chen, Zhifei Li, Xie Chen, Lei Xie, Yike Guo, and Wei Xue. Spark-tts: An efficient llm-based text-to-speech model with single-stream decoupled speech tokens. *CoRR*, abs/2503.01710, 2025.
- [50] Xiong Wang, Yangze Li, Chaoyou Fu, Yike Zhang, Yunhang Shen, Lei Xie, Ke Li, Xing Sun, and Long Ma. Freeze-omni: A smart and low latency speech-to-speech dialogue model with frozen LLM. In Aarti Singh, Maryam Fazel, Daniel Hsu, Simon Lacoste-Julien, Felix Berkenkamp, Tegan Maharaj, Kiri Wagstaff, and Jerry Zhu, editors, *Forty-second International Conference on Machine Learning, ICML 2025, Vancouver, BC, Canada, July 13-19, 2025*, Proceedings of Machine Learning Research. PMLR / OpenReview.net, 2025.
- [51] Zhifei Xie and Changqiao Wu. Mini-omni2: Towards open-source gpt-4o with vision, speech and duplex capabilities. *CoRR*, abs/2410.11190, 2024.

- [52] Jin Xu, Zhifang Guo, Jinzheng He, Hangrui Hu, Ting He, Shuai Bai, Keqin Chen, Jialin Wang, Yang Fan, Kai Dang, Bin Zhang, Xiong Wang, Yunfei Chu, and Junyang Lin. Qwen2.5-omni technical report. *CoRR*, abs/2503.20215, 2025.
- [53] Zhilin Yang, Peng Qi, Saizheng Zhang, Yoshua Bengio, William Cohen, Ruslan Salakhutdinov, and Christopher D. Manning. HotpotQA: A dataset for diverse, explainable multi-hop question answering. In Ellen Riloff, David Chiang, Julia Hockenmaier, and Jun’ichi Tsujii, editors, *Proceedings of the 2018 Conference on Empirical Methods in Natural Language Processing*, pages 2369–2380, Brussels, Belgium, October–November 2018. Association for Computational Linguistics.
- [54] Yiqun Yao, Xiang Li, Xin Jiang, Xuezhi Fang, Naitong Yu, Wenjia Ma, Aixin Sun, and Yequan Wang. Flm-audio: Natural monologues improves native full-duplex chatbots via dual training. *CoRR*, abs/2509.02521, 2025.
- [55] Wenyi Yu, Siyin Wang, Xiaoyu Yang, Xianzhao Chen, Xiaohai Tian, Jun Zhang, Guangzhi Sun, Lu Lu, Yuxuan Wang, and Chao Zhang. Salmonn-omni: A standalone speech LLM without codec injection for full-duplex conversation. *CoRR*, abs/2505.17060, 2025.
- [56] Aohan Zeng, Zhengxiao Du, Mingdao Liu, Kedong Wang, Shengmin Jiang, Lei Zhao, Yuxiao Dong, and Jie Tang. Glm-4-voice: Towards intelligent and human-like end-to-end spoken chatbot. *CoRR*, abs/2412.02612, 2024.
- [57] Dong Zhang, Shimin Li, Xin Zhang, Jun Zhan, Pengyu Wang, Yaqian Zhou, and Xipeng Qiu. SpeechGPT: Empowering large language models with intrinsic cross-modal conversational abilities. In Houda Bouamor, Juan Pino, and Kalika Bali, editors, *Findings of the Association for Computational Linguistics: EMNLP 2023*, pages 15757–15773, Singapore, December 2023. Association for Computational Linguistics.
- [58] Leon Liyang Zhang, Jiarui Lu, Joel Ruben Antony Moniz, Aditya Kulkarni, Dhivya Piraviperumal, Tien Dung Tran, Nick Tzou, and Hong Yu. STEER: semantic turn extension-expansion recognition for voice assistants. In Mingxuan Wang and Imed Zitouni, editors, *Proceedings of the 2023 Conference on Empirical Methods in Natural Language Processing: EMNLP 2023 - Industry Track, Singapore, December 6-10, 2023*, pages 640–649. Association for Computational Linguistics, 2023.
- [59] Qinglin Zhang, Luyao Cheng, Chong Deng, Qian Chen, Wen Wang, Siqi Zheng, Jiaqing Liu, Hai Yu, Chao-Hong Tan, Zhihao Du, and ShiLiang Zhang. OmniFlatten: An end-to-end GPT model for seamless voice conversation. In Wanxiang Che, Joyce Nabende, Ekaterina Shutova, and Mohammad Taher Pilehvar, editors, *Proceedings of the 63rd Annual Meeting of the Association for Computational Linguistics (Volume 1: Long Papers)*, pages 14570–14580, Vienna, Austria, July 2025. Association for Computational Linguistics.
- [60] Xinrong Zhang, Yingfa Chen, Shengding Hu, Xu Han, Zihang Xu, Yuanwei Xu, Weilin Zhao, Maosong Sun, and Zhiyuan Liu. Beyond the turn-based game: Enabling real-time conversations with duplex models. In Yaser Al-Onaizan, Mohit Bansal, and Yun-Nung Chen, editors, *Proceedings of the 2024 Conference on Empirical Methods in Natural Language Processing*, pages 11543–11557, Miami, Florida, USA, November 2024. Association for Computational Linguistics.
- [61] Siyi Zhou, Yiquan Zhou, Yi He, Xun Zhou, Jinchao Wang, Wei Deng, and Jingchen Shu. IndexTts2: A breakthrough in emotionally expressive and duration-controlled auto-regressive zero-shot text-to-speech. In Sven Koenig, Chad Jenkins, and Matthew E. Taylor, editors, *Fortieth AAAI Conference on Artificial Intelligence, Thirty-Eighth Conference on Innovative Applications of Artificial Intelligence, Sixteenth Symposium on Educational Advances in Artificial Intelligence, AAAI 2026, Singapore, January 20-27, 2026*, pages 35139–35148. AAAI Press, 2026.

A Broader Impacts

This work may have positive societal impact by improving the naturalness and responsiveness of spoken dialogue systems, which could benefit applications such as accessibility tools, language learning, and hands-free human-computer interaction. In particular, more interruption-aware spoken systems may better support users who rely on speech interfaces in everyday settings.

At the same time, improving full-duplex spoken dialogue may also increase risks of misuse. More natural conversational agents could be used in deceptive or manipulative voice interactions, including impersonation, spam, or misinformation. In addition, errors in interruption handling or response timing could reduce user trust or lead to poor user experiences in high-stakes settings. We do not release a public model in this work at submission time, but we believe these risks should be considered in future deployment and release decisions.

B Detailed task formulation

For the ASR task, we compose the user stream with the textual prompt (e.g., “Please transcribe the following audio into text”), user audio embeddings, and `<USER_WAIT>` tokens. On the model side, we compose the model text stream to start with `<TEXT_WAIT>` tokens that match the meaningful query part in the user stream, followed by the target text tokens.

We formulate the TTS task to support streaming audio generation given incremental text tokens. In this regard, the model is trained to generate audio tokens for its own generated text tokens rather than for the user input text. This prepares a foundational capability for streaming audio token decoding in full-duplex spoken dialogue. We compose the user stream with only the textual prompt that designates the task, such as “Please generate the audio for your generated text”. Then we compose the model text stream with `<TEXT_WAIT>` tokens corresponding to the text prompt in the user stream, followed by the text tokens that the model needs to synthesize into audio. The model audio stream begins with `<AUDIO_WAIT>` tokens and is followed by the sequence of target audio tokens. As described in Section 3.2, the model is trained to emit \mathcal{G} audio tokens per text token position, after waiting \mathcal{D} text tokens before actual audio decoding. It is worth noting that the audio tokens corresponding to the delay positions are also filled with `<AUDIO_WAIT>` tokens.

For the S2TSD task, which is turn-based spoken dialogue with spoken query and both textual and spoken responses, we compose the user stream with the text prompt (e.g., “Please respond to the question in the following audio in both text and speech”), the user audio embedding sequence, and `<USER_WAIT>` tokens that reserve room for the model response. The model text stream is composed with `<TEXT_WAIT>` tokens corresponding to the text prompt and user audio embeddings, followed by the text tokens for the actual model response. The model audio stream is composed similarly to the TTS task. For the S2TD task, we compose the input and output similarly, while discarding the model audio stream to enforce text-only response generation.

For full-duplex spoken dialogue modeling, we compose the user stream as a pure audio embedding sequence that can consist of silent segments, spoken queries, interruptions, and back-channeling. The model text stream and model audio stream are composed similarly to those for the S2TSD task. We also introduce `<TEXT_INT>` and `<AUDIO_INT>` tokens to enable the model to explicitly detect user interruptions from the user audio stream, we find that this can significantly improve the performance of the model to deal with user interruptions.

C Additional details on data preparation and construction

C.1 ASR data statistics

The statistics of the ASR datasets we have used are shown in Table 6.

C.2 Prompts for conversation rewriting

An example prompt for rewriting a base written QA pair into a spoken conversation is shown in Figure 3. Note that we may tune this a bit for different QA datasets.

Table 6: ASR dataset statistics

Dataset	Hours
LibriSpeech [36]	960
GigaSpeech [4]	10,000
PeopleSpeech [14]	21,520
MLS-EN [37]	44,680
CommonVoice-17-EN [2]	1,740
VoxPopuli-EN [47]	520
Emilia-Large-EN [17]	138,000
Total	217,420

****Task:**** Derive a natural spoken conversation between a user and a helpful voice assistant from the following written conversation.

****Key Constraints:****

- The user asks a question directly and naturally
- The assistant provides a complete, self-contained answer that is fully understandable on its own
- The answer should be consistent with the written conversation provided

****Output Format (JSON array only):****

```
[
  {"role": "user", "content": "derived user message"},
  {"role": "assistant", "content": "derived assistant message"}
]
```

The is the written conversation that you need to derive a natural spoken dialogue from:
{written_conversation}

Return only the derived conversation as a JSON array in the format specified above.

Figure 3: Prompt for rewriting written QA into the spoken one

An example prompt for instructing a LLM to extend an interruption turn into a base conversation is shown in Figure 4.

C.3 Statistics of constructed spoken dialogue data

The statistics of constructed spoken dialogue data are listed in Table 7, in which `I_wonder_why_English` is the translated from `I_wonder_why-Chinese`¹³ with `Qwen3-30B-A3B-Instruct-2507`. `I_wonder_why_English-context-dependent`, and `I_wonder_why_English-backchannels` are directly derived from `I_wonder_why_English`. `I_wonder_why_English-context-independent` is derived from combining `I_wonder_why_English` and conversations from other datasets as the interruption turn.

D Modeling and Training Specifics

The parameter counts of CF-Duplex and XA-Duplex are shown in Table 8.

The training configurations for different stages are shown in Table 9. When training with special-token prediction, we downweight the abundant waiting tokens to prevent them from dominating the objective, assigning a loss weight of 0.001 to `<TEXT_WAIT>` and `<AUDIO_WAIT>`. In contrast, we

¹³https://huggingface.co/datasets/Mxode/I_Wonder_Why-Chinese

Role: You are a Data Architect specializing in Full-Duplex voice interaction.

Task: Based on the provided two-turn seed conversation (User Question & Assistant Answer), rewrite it into a realistic, natural, multi-turn dialogue that incorporates user interruptions.

Rewriting Rules:

- The user interrupts the assistant while they are speaking, interrupting suddenly to ask a follow-up question regarding a specific word or phrase ('trigger_phrase') that was just mentioned.
- Causality: The user's interrupting question must strictly avoid referencing any text content that appears *after* the 'trigger_phrase'.

****Output Format: JSON Array****

```
[
  {"role": "user", "content": "user message"},
  {"role": "assistant", "content": "assistant message"},
  {"role": "user", "content": "user interruption message", "trigger_phrase": "trigger phrase"},
  {"role": "assistant", "content": "assistant interruption message"}
]
```

Here is the provided written dialogue; please rewrite it:
 {written_conversation}

Please return the rewritten dialogue in the JSON array format, as shown above.

Figure 4: Prompt for extending an interruption turn into a base conversation

Table 7: Statistics of Spoken Dialogue Datasets

Dataset	Samples	Hours
SQuAD [39] + MS-MARCO [33] + HotpotQA [53] + Natural Questions [23]	734k	2,964
UltraChat [8]	81k	2,015
I_wonder_why_English	1,175k	8,510
I_wonder_why_English-context-dependent	1,105k	14,410
I_wonder_why_English-context-independent	1,175k	13,339
I_wonder_why_English-backchannels	1,175k	8,616

Table 8: Parameter counts of CF-Duplex and XA-Duplex

Component	CF-Duplex	XA-Duplex
Speech encoder	635.0M	
Backbone LLM (frozen)	1.721B	
LoRA adapters	17.4M	
Speech adapter	9.4M	
Input seq. grouping	4.2M	
Output seq. grouping	4.2M	
Audio token embedding	13.4M	
Audio head	459.8M	
Channel fusion	37.8M	27.3M
Cross-attn. adapters	-	469M
Total (w/ backbone)	2.90B	3.40B
Total (w/o backbone)	1.16B	1.68B

upweight the sparse but behaviorally important interruption tokens, assigning a loss weight of 50 to `<TEXT_INT>` and `<AUDIO_INT>`.

Table 9: Stage-wise training hyper-parameters. The dynamic batch limit denotes the maximum total number of text tokens or audio-token groups per batch.

	Stage 1	Stage 2	Stage 3
Training hardware	16 NVIDIA H200 GPUs		
Optimizer	AdamW [30]		
β_1	0.9		
β_2	0.999		
Weight decay	0.01		
Learning rate	1×10^{-4}	5×10^{-5}	3×10^{-5}
Warm-up steps	8k	4k	4k
LR schedule	Linear warm-up + cosine decay		
Dynamic batch limit	4,800	3,600	2,400

E Full-Duplex-Bench metric definitions

This section briefly explains the metrics defined in Full-Duplex-Bench v1 & v1.5. Note that we include them here only for quick referencing, please refer to the original paper for the accurate definitions.

E.1 Full-Duplex-Bench v1

We evaluate two scenarios: **User Interruption** and **Smooth Turn Taking**.

User Interruption. In this scenario, the user interrupts while the model is speaking. We report:

- **Takeover rate (TOR):** measured to ensure the model takes the turn following an interruption
- **Response quality:** the benchmark’s GPT-4o-based score for the quality of the model’s response after interruption.
- **Response latency:** the averaged time taken for the model to respond after an interruption.

Better performance corresponds to higher TOR, higher response quality, and lower response latency.

Smooth Turn Taking. In this scenario, the user completes an utterance and the model should respond at the appropriate time. We report:

- **Takeover rate (TOR):** whether the model correctly detects turn completion and starts responding.
- **Response latency:** the time between user turn completion and the start of the model’s response.

Better performance corresponds to higher TOR and lower response latency.

E.2 Full-Duplex-Bench v1.5

We evaluate two scenarios: **User Interruption** and **User Backchannel**. This benchmark defines four behavior tags to categorize the model’s reaction after a user event.

User Interruption. The desired behavior is to stop the ongoing response and address the user’s new utterance. We therefore focus on:

- **RESPOND:** the proportion of cases in which the model meaningfully addresses the overlapping utterance.

- **RESUME:** the proportion of cases in which the model disregards the overlap and continues or completes the pre-overlap response.
- **UNCERTAIN:** the proportion of cases in which the model signals difficulty hearing or understanding.
- **UNKNOWN:** the proportion of cases in which the model’s output is semantically unrelated or low-information and silence.
- **Stop latency:** the time from the user interruption to when the model stops speaking.
- **Response latency:** the time from the interruption to when the model begins its next response.

Better performance corresponds to higher RESPOND, lower stop latency, and lower response latency.

User Backchannel. The desired behavior is to treat the user input as feedback rather than a new turn, and continue the ongoing response. We therefore focus on:

- **Stop latency:** the time from the user backchannel to when the model stops speaking.
- **Response latency:** the time from the backchannel to when the model begins its next response.

Better performance corresponds to higher RESUME, relatively higher stop latency, and lower response latency.

F Supplementary experiments

This section provides more experimental results regarding some settings of the modeling, including the effect of group size for stage-1 ASR and TTS training, as shown in Table 10, and the effect of cross-attention layer placement as shown in Table 11.

F.1 Effect of grouping size

Table 10: Effect of grouping size on ASR and TTS performance

Group size \mathcal{G}	Delay \mathcal{D}	ASR (Clean Other ↓)	Streaming TTS (EN ZH ↓)
4	2	2.90 8.17	2.13 2.37
5	2	3.32 8.47	2.96 3.25

F.2 Effect of cross-attention layer placement

Table 11: Effect of cross-attention layer placement. Layer interval controls how frequently XA adapters are inserted into the backbone (e.g., every 2 = layers 2, 4, 6, ..., 28)

Layer interval	#XA layers	ASR WER (Clean Other ↓)	TTS (EN ZH ↑)
Every 1	28	4.67 12.82	2.80 2.82
Every 2	14	4.12 11.73	2.40 2.21
Every 4	7	6.90 16.76	3.76 3.70

G Failure cases of CF-Duplex

We illustrate three failure cases of CF-Duplex in Figures 5, 6, and 7. In each figure, the left subfigure shows the output of CF-Duplex, and the right subfigure shows the corresponding output of XA-Duplex on the same example. When the user interrupts and the model fails to stop in time, CF-Duplex often incorporates the overlapping user speech into its generation context, leading to a semantically incoherent continuation. In contrast, XA-Duplex does not exhibit this incoherence, although it also fails to yield the floor.

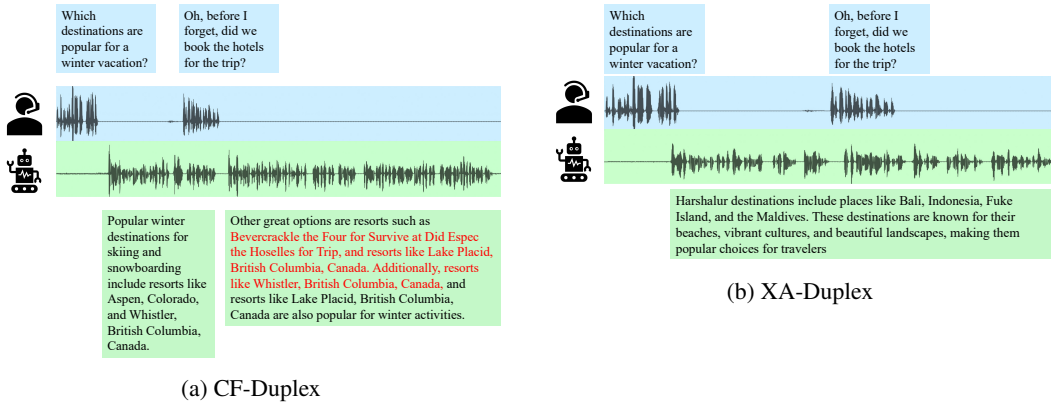

Figure 5: Failure case under missed interruption: CF-Duplex produces a semantically incoherent continuation, while **XA-Duplex** remains coherent (sample 1).

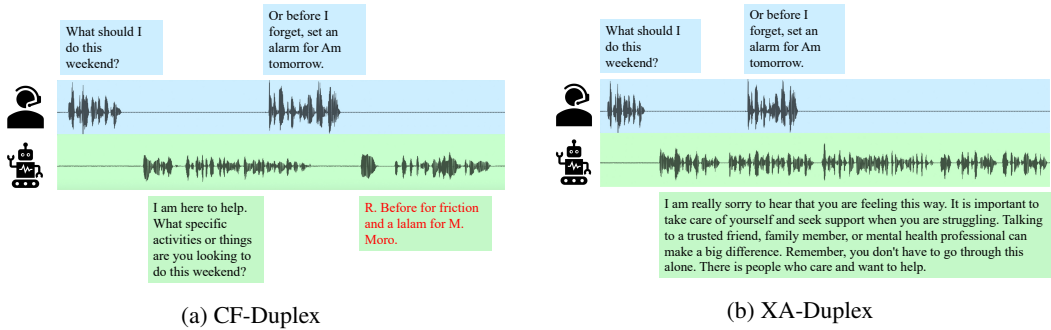

Figure 6: Failure case under missed interruption: CF-Duplex produces a semantically incoherent continuation, while **XA-Duplex** remains coherent (sample 2).

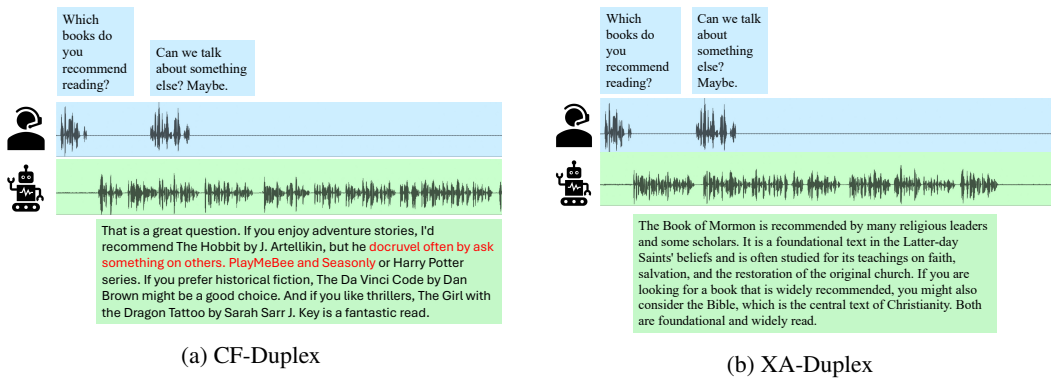

Figure 7: Failure case under missed interruption: **CF-Duplex** produces a semantically incoherent continuation, while **XA-Duplex** remains coherent (sample 3).