

VO₂ films grown on TiO₂ sub-layer: influence of thickness on structural, electrical and optical properties

M. E. Kutepov^{1,*}, V. E. Kaydashev^{1*}, D.V. Stryukov², A.S. Konstantinov³, A.V. Nikolskiy⁴, A.T. Kozakov⁴, A.D. Morozov⁵ and E. M. Kaidashev¹

¹*I. I. Vorovich Mathematics, Mechanics and Computer Science Institute, Laboratory of Nanomaterials, Southern Federal University, 200/1 Stachki Ave., 344090 Rostov-on-Don, Russia*

²*Federal Research Centre The Southern Scientific Centre of the Russian Academy of Sciences, Chekhov Ave., 41, 344006, Rostov-on-Don, Russia*

³*Physics Faculty, Southern Federal University, 5 Zorge St., 344090 Rostov-on-Don, Russia*

⁴*Institute of Physics, Southern Federal University, 194 Stachki Ave., 344090 Rostov-on-Don, Russia*

⁵*Moscow Institute of Physics and Technology (MIPT), Institutskiy 9, 141701 Dolgoprudny, Russia*

kutepov.max@yandex.ru*, kaydashev@gmail.com*

Abstract

Vanadium dioxide with metal-to-insulator transition (MIT) that is triggered by heat, current or light is a promising material for modern active THz/mid-IR metasurfaces and all-optical big data processing systems. Multilayer VO₂-based active metasurfaces are urgently needed however several important issues related to VO₂ properties in VO₂/TiO₂/Al₂O₃ films should be thoroughly examined first. We study electrical, optical and structural properties of VO₂ films as well as their composition and switching characteristics as function of the VO₂ layer thickness in VO₂/TiO₂ composites. XRD analysis revealed an epitaxial growth of films with deformation of the monoclinic VO₂ lattice to hexagonal symmetry. Reduced VO₂ layer thickness from 170 nm to 20 nm results in increased phase transition temperature while the width of the resistance versus temperature hysteresis loop $R(T)$ remains constant at ~6 °C for all VO₂ thicknesses in the range of 20-170 nm. The resistance alteration ratio ΔR_{ratio} is reduced from 4.2×10^3 to 2.7×10^2 in thinner films. Raman spectra reveal a significant shift of VO₂ lattice vibration modes for films thinner than 30 nm claiming a great structural strain whereas modes position for thicker VO₂ layers are similar to those in bulk structure. Composition of VO₂ films has revealed only a minor alteration of VO₂/V₂O₅ phases ratio from 1.6 to 1.8 when the film thickness has been increased from 20 nm to 50 nm. Investigation of surface elemental composition and valence states of VO₂ films revealed that VO₂/V₂O₅ ratio remains practically unchanged with thickness reduction. The study of electrical MIT dynamics revealed the switching time of a 50 nm VO₂ film to be as low as 800 ns.

Keywords: pulsed laser deposition (PLD), VO₂, metal-insulator transition (MIT), TiO₂, thin films, sapphire, x-ray photon spectroscopy (XPS), Raman spectroscopy.

Introduction

Vanadium dioxide has recently attracted much attention as a prospective material for active THz/ middle IR metasurfaces [1–5], NIR waveguide modulators [6–8], LIDARs [7] and big data development using all-optical image processing [9], middle IR photodetectors [10, 11], smart windows [12], and other applications in optoelectronics.

High quality epitaxial VO₂ films do typically show resistance change for 3-4 orders of magnitude due to metal-to-insulator transition (MIT) as well as narrow R(T) hysteresis loop which are both key important properties for fast and deep optical modulation in all near IR, middle IR and THz ranges.

Historically first, high crystalline epitaxial films were grown on sapphire or titanium dioxide monocrystal substrates, which best fit to lattice parameters of vanadium dioxide [13]. Later, many efforts were undertaken to prepare VO₂ films with needed electric characteristics on cheaper silicon [7, 8], TiO₂-buffered SiO₂/Si and flexible TiO₂/polyimide substrates [14]. However, the former VO₂ films are typically amorphous and do reveal a resistance alteration of only 1.5-2 orders of magnitude due to MIT.

Multilayer structures with high quality epitaxial VO₂ layers that possess simultaneously excellent structural characteristics, large IR/THz modulation, narrow resistance hysteresis loop and fast electric switching are highly desired. In particular, such films are expected to boost the progress in multi-layer VO₂-based active THz/IR metasurfaces the technology of which is still challenging. VO₂-based active metasurfaces should be cost-effective and, thus, might be controlled with direct thermal heating or indirect heating by microsecond/nanosecond electric current pulses or by cheap continuous lasers. In all these cases a metal-to-insulator transition is occurred in VO₂ due to temperature induced structural transition in a time window from microseconds [7] to seconds and shorter responses of several tens of nanoseconds are rear reported [6]. Indeed, VO₂ device backward switching rate is limited by the process of the heat dissipation that is function of a film thickness. The reduction of VO₂ layer thickness allows one boost the backward VO₂ switching rate [15]. However, when the thickness of the VO₂ layer is only 10 nm or less, typically a significant lattice strains are observed. This results in a significant degradation of the R(T) hysteresis loop, namely, a broadening as well as a decreased ratio of films conductivity in metallic and dielectric states [16].

Several efforts were undertaken to follow the influence of substrate type and VO₂ thickness on the electric switching dynamics. Namely, VO₂ films grown on expensive single crystalline TiO₂ substrates [17] and more cost-effective TiO₂-buffered Al₂O₃ substrates [18] were characterized. Remarkable, that VO₂ films prepared on single crystalline TiO₂ do reveal only a bit less strains compared to VO₂ layers grown on much more cost-effective Al₂O₃ substrates [17]. Also, structural strains become more pronounced in ultrathin VO₂ films prepared on TiO₂/m-Al₂O₃ substrates which results in significant shift of MIT hysteresis loop to room temperature [19].

The forward and backward switching times more often were studied for Si near IR waveguide modulators [6–8] and best backward switching times as short as ~36 ns and ~74 ns were achieved [6]. However, it is not clear from these studies either these times correspond to complete switching between semiconductor and metallic states or just to a minor resistance alteration which is typically occurred faster. Indeed, even partial electric switching that is occurred in first quarter of MIT hysteresis is already capable to result in significant IR waveguide modulation [7]. However, the minor resistance alteration is not enough to modulate middle IR and THz reflection/transmission. Moreover, very controversial results obtained in [19-21] and in [9] on the influence of structural strain in VO₂ lattice on the optical and electric switching characteristics need further experimental efforts to shed more light on this topic.

Meanwhile, it is already now clear that thin VO₂ films on TiO₂-buffered c-Al₂O₃ substrates are promising candidate to fabricate cost-effective quality multilayer active THz/middle IR metasurfaces. Such films are the subject of the present careful examination. First, the use of a TiO₂ sub-layer is dictated by the need to replace an expensive single-crystalline TiO₂ substrate by more cost-effective counterpart. Indeed, quite good fit of lattice parameters at both interfaces of VO₂/TiO₂ and TiO₂/Al₂O₃ makes it possible to obtain high quality epitaxial layers [20]. Second, the technology for multilayer VO₂/TiO₂/VO₂/TiO₂/.../Al₂O₃ structures is urgently needed. Indeed,

TiO₂ layers act also as dielectric spacers between active VO₂ layers and combining functional and dielectric layers is beneficiary. However, there is still a trade-off between the film thickness, crystalline structure quality, reverse switching rate and a conductivity modulation depth.

The TiO₂ buffer layer deposition temperature in the range of 650-700 °C as well as TiO₂ sub-layer thickness were both found to influence the abruptness and position of the MIT hysteresis loop of VO₂ [16]. Also, they have found that the VO₂/TiO₂/m-Al₂O₃ structure is already nearly completely unstrained and a MIT is observed at ~50 °C when the thickness of a TiO₂ buffer layer is greater than ~200 nm [16].

We study optimal pulsed laser deposition regimes to fabricate epitaxial VO₂ films on TiO₂-buffered c-Al₂O₃ substrates that will be further used in multi-layered active THz and middle IR metasurfaces. To assemble more complete picture on properties of VO₂/TiO₂/c-Al₂O₃ composites we study the films obtained at varied oxygen pressure and VO₂ layer thickness. Namely, we analyze films structural properties, phase composition, the influence of temperature triggered MIT on conductivity, middle IR reflection and lattice vibration dynamics. Electrically induced switching dynamics is examined as well.

Experimental

First, we studied the properties of VO₂ films prepared at TiO₂/c-Al₂O₃ substrates at varied oxygen pressure. For this purpose, a series of VO₂ films was synthesized using the PLD method on c-Al₂O₃ substrates with preliminary deposited TiO₂ buffer sub-layer. The VO₂ ceramic target was positioned at distance of 5 cm from the substrate. Radiation of KrF laser (CL7100, 248 nm, 10 Hz) was focused onto the surface of ceramic rotating target to obtain fluence of 2 J/cm². The substrate temperature was maintained at 550°C, and the oxygen pressure was altered in the range of 1 – 3×10⁻² mbar for different regimes. The rate of VO₂ film growing was estimated to be ~0.425 Å/pulse and a ~170 nm thick film was grown for 4000 laser pulses. As prepared VO₂ films were *in-situ* annealed during 15 min at oxygen pressure and temperature used for synthesis. The TiO₂ buffer layers were deposited at temperature of 650 °C and oxygen pressure of 3×10⁻² mbar, respectively. The ~170 nm thick TiO₂ layers were deposited for all samples in present study. Other parameters during the growth of TiO₂ sub-layer were the similar to those used for deposition of VO₂. Also, VO₂ film on base c-Al₂O₃ substrate without a TiO₂ sub-layer was deposited as a Reference Sample at oxygen pressure of 2×10⁻² mbar. Other parameters were the similar to those for VO₂/TiO₂/c-Al₂O₃ films.

Next, correlation between VO₂ layer thickness and the composite VO₂/TiO₂/c-Al₂O₃ properties was examined. More specifically, VO₂ layers with thickness of 170 nm, 50 nm, 30 nm, 20 nm we deposited on TiO₂-buffered c-Al₂O₃ substrates at oxygen pressure of 3×10⁻² mbar and temperature of 550°C.

X-ray diffraction studies were carried out using the RIKOR multifunctional X-ray complex, Bragg-Brentano focusing, CuK_α radiation (30 kV, 10 mA), Ni β-filter. The scanning step was 0.01° for θ-2θ scan and 0.4° for φ scan, correspondingly.

Raman spectra of the VO₂/TiO₂ films were studied using Renishaw inVia Reflex Raman spectrometer with spectral resolution better than 1 cm⁻¹. The samples were excited at 514 nm with Ar⁺ laser light. A ×50 objective with a long focal distance (NA=0.5) was used for excitation and scattered light collection. A backward scattered radiation was collected in geometry, polarizers for incident and scattered light were not used. The incident light fluence did not exceed 0.74×10⁵ W/cm² and, thus, the sample heating was minor.

X-ray Photoelectron Spectra (XPS) were obtained using ESCALAB 250 X-ray photoelectron microprobe. The samples were excited by monochromatic AlK_α radiation focused to the spot of 500 μm. The absolute resolvable

energy interval was 0.6 eV, which was determined using the $\text{Ag}3d_{5/2}$ line. The binding energies in spectra were determined using the C1s calibration line at 285.0 eV.

Results and discussion

The studied θ - 2θ X-ray diffraction patterns revealed only reflections from the VO_2 , TiO_2 layers and the Al_2O_3 substrate, no reflections associated with impurity phases were detected (see Fig. 1s (a) of Supplementary material). The monoclinic symmetry of the unit cell with parameters $a = 5.752$, $b = 4.538$, $c = 5.382$ Å, and $\beta = 122.65^\circ$ is the most probable for vanadium dioxide at room temperature. In accordance with this symmetry, Miller indices are denoted below. The fact that θ - 2θ X-ray diffraction patterns reveal only reflections of the (0k0) type for the VO_2 film and (00l) for the Al_2O_3 substrate indicates the co-direction of the [010] VO_2 and [0001] Al_2O_3 axes. Excellent structural properties of the films are confirmed by narrow lines in θ - 2θ X-ray diffraction patterns as well as in the rocking curves (see Fig. 1s (b) of Supplementary material). VO_2 films revealed [010] axis normal to the substrate with misorientation smaller than 0.5° for all $\text{VO}_2/\text{TiO}_2/\text{Al}_2\text{O}_3$ samples. Remarkable, that for VO_2 layer deposited directly on Al_2O_3 the misorientation showed a bit higher value of 0.65° .

The epitaxial growth of all studied films was confirmed by φ -scanning of the (220) reflection as shown in Fig. 1a. More specifically, six maxima are observed on the φ -scans of (220) reflection, where the distance between adjacent maxima was measured to be 60° . This suggests that the angle β in the conjugation plane is equal to 120° . It is highly likely that the deposition of VO_2 on Al_2O_3 or on $\text{TiO}_2/\text{Al}_2\text{O}_3$ is occurred with distortion of the VO_2 unit cell to hexagonal symmetry for all studied films and the [010] axis of the monoclinic cell of VO_2 becomes a sixth order axis. Locations of the atoms of the VO_2 film and the Al_2O_3 substrate in the conjugation plane are shown in Fig. 1b and Fig. 1c, correspondingly.

The angular positions of VO_2 (220) reflections on φ -scans in respect to (104) reflections of the c- Al_2O_3 substrate indicate that VO_2 unit cell is a rotated for 30° in respect to the Al_2O_3 unit cell (Fig. 1a). From θ - 2θ X-ray diffraction patterns of (0k0) VO_2 reflections we determine parameter “b” of the unit cell in the direction normal to the substrate surface (Fig. 1 d). The “b” parameters for all films are slightly altered from 4.546 ± 0.005 Å for a film deposited on $\text{TiO}_2/\text{Al}_2\text{O}_3$ at $P(\text{O}_2)=1 \times 10^{-2}$ mbar to 4.517 ± 0.005 Å for a film deposited on Al_2O_3 without a sublayer. The maximum difference in the parameters of the unit cell “b” is 0.029 Å, which corresponds to a cell deformation not exceeding 0.6%.

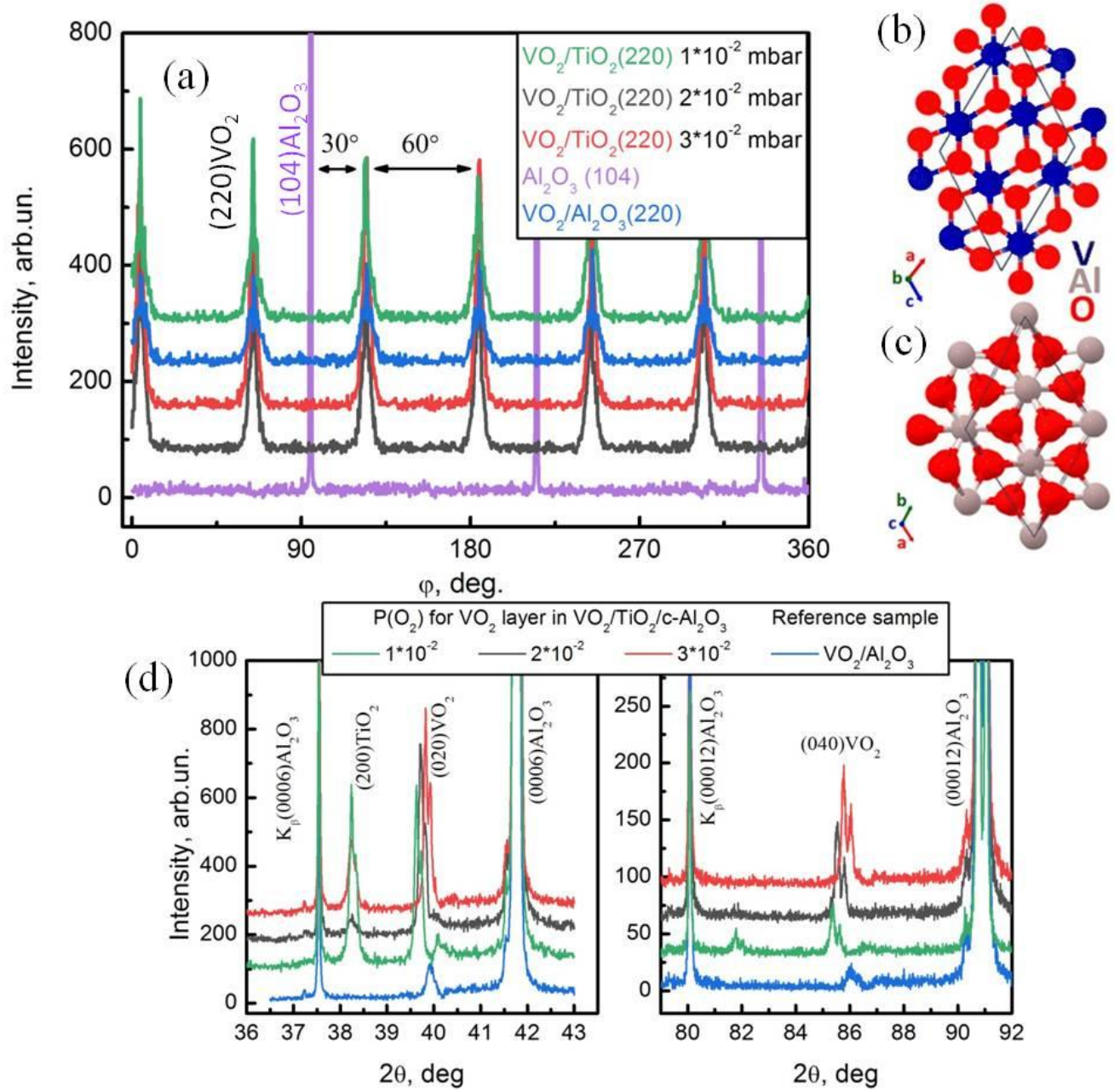

Fig. 1 ϕ -scanning x-ray diffraction patterns of (220) VO_2 reflection of studied films and reflection (104) of the Al_2O_3 substrate (a). Orientation of the monoclinic VO_2 lattice (b) and the hexagonal Al_2O_3 lattice (c). Precision θ - 2θ X-ray diffraction patterns of studied films (d). Blue lines in (c) and (d) correspond to $\text{VO}_2/\text{c-Al}_2\text{O}_3$ Ref. sample.

The MIT related alteration of the VO_2 layer resistance as function of temperature $R(T)$ for (170 nm) $\text{VO}_2/\text{TiO}_2/\text{c-Al}_2\text{O}_3$ films prepared at different oxygen pressure is shown in Fig. 2. The derivative of $d(\log_{10}(R))/dT$ with minimum at MIT curve inflection point corresponding to sample deposited at oxygen pressure of 3×10^{-2} mbar is shown in the inset. All the samples prepared at oxygen pressure in the range of $1-3 \times 10^{-2}$ mbar reveal the resistance alteration for more than 3 orders of magnitude due to MIT and small hysteresis width of 5 – 6,1 $^\circ\text{C}$. The metallic state resistance is varied from 40 to 350 Ω for samples grown at different pressure. We speculate that abrupt MIT curve behavior evidences the high structural quality of VO_2 .

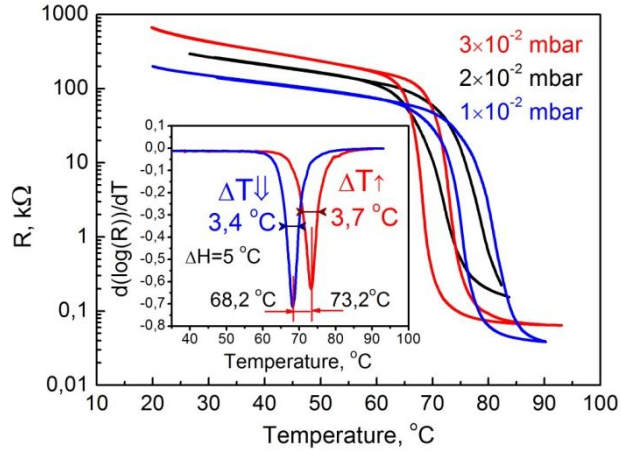

Fig. 2 MIT induced resistance alteration as function of temperature for VO₂/TiO₂/c-Al₂O₃ films obtained at different oxygen pressure $P(O_2)$ in the range of 1 – 3×10^{-2} mbar. The derivative of $d(\log_{10}(R))/dT$ as function of temperature for sample obtained at $P(O_2) = 3 \times 10^{-2}$ mbar is shown in inset.

The more detailed parameters of metal-to-insulator phase transition such as phase transition temperature (T_{PT}), sharpness (ΔT) and width (ΔH) of thermal hysteresis were defined from the temperature dependences of the derivative $d(\log_{10}(R))/dT$ shown in Fig. S2 of Supplementary material and are summarized in Table 1. According to data in Table 1 we conclude that the film deposited at oxygen pressure of 3×10^{-2} mbar shows the best characteristics, namely the most abrupt MIT, greatest resistance alteration ratio ΔR_{ratio} and narrow hysteresis loop. Thus, we use this VO₂ film deposition regime for all the samples in second part of our study to characterize the influence of VO₂ layer thickness on the properties of VO₂/TiO₂/c-Al₂O₃ composite.

Table 1 Phase transition temperature T_{PT} , abruptness ΔT , hysteresis width ΔH , minimal resistance R_{min} in metallic state and ratio of the resistance alteration ΔR_{ratio}

| PO_2 (mbar) | T_{PT} (°C) | ΔT (°C) | R_{min} (kΩ) | ΔH (°C) | ΔR_{ratio} |
|--------------------|---------------|-----------------|----------------|-----------------|--------------------|
| 1×10^{-2} | 78,6 | 5,1 | 0,04 | 6 | $3,9 \times 10^3$ |
| 2×10^{-2} | 71,45 | 5,7 | 0,35 | 6,1 | $3,1 \times 10^3$ |
| 3×10^{-2} | 70,7 | 3,55 | 0,09 | 5 | $6,7 \times 10^3$ |

For the transition temperature T_{PT} and abruptness ΔT the values are given by averaging numbers for heating and cooling curves.

Next, we study the evolution of VO₂/TiO₂ composites properties of four structures with VO₂ layer thickness of 20 nm, 30 nm, 50 nm and 170 nm in samples S1-S4, correspondingly.

The valence states of revealed elements and oxide phases content on the surface of studied composites were characterized using XPS method. Binding energies and relative content of the V_{2p} and O_{1s} components in XPS spectra of Samples S1-S4 are given in Table 3. All the spectra reveal two V_{2p} related lines with binding energy of 516.4 eV and 517.8 eV which were assigned to belong to VO₂ and V₂O₅ oxide phases, respectively. The VO₂/V₂O₅ ratio is slightly increased from 1,6 to 1,8 for thicker VO₂ layers, however vanadium dioxide remains the prevailing phase for all films. Thus, the alteration of the elemental composition in thinner VO₂ layers is minor.

Table 3 Binding energies (eV) and relative content (%) of the V_{2p} and O_{1s} components in XPS spectra

| Sample | Valence | Area*, a.u. | VO ₂ /V ₂ O ₅ | Thickness, nm |
|--------|-----------------|-------------|--|---------------|
| S1 | V ⁴⁺ | 14,0 | 1,63 | 20 |
| | V ⁵⁺ | 8,6 | | |
| S2 | V ⁴⁺ | 17,35 | 1,74 | 30 |
| | V ⁵⁺ | 10,2 | | |
| S3 | V ⁴⁺ | 17,7 | 1,8 | 50 |
| | V ⁵⁺ | 9,85 | | |
| S4 | V ⁴⁺ | 17,65 | 1,81 | 170 |
| | V ⁵⁺ | 10,1 | | |

* Area under the curve of the respective peak.

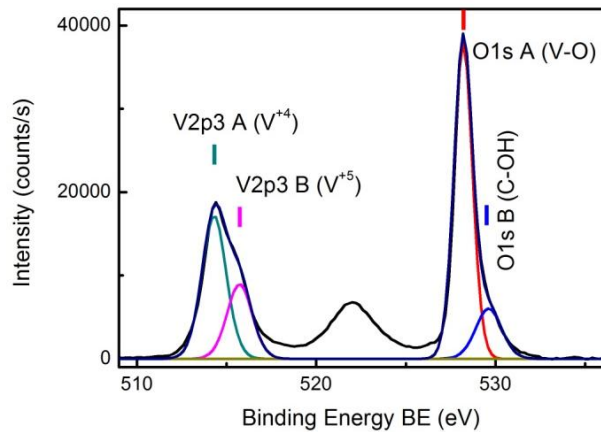

Fig. 3 X-Ray Photoelectron Spectrum measured on the surface of VO₂/TiO₂/c-Al₂O₃ composite film in Sample S3.

Raman spectra measured for samples S1-S4 with altered VO₂ film thicknesses are shown in Fig. 4. The spectra of sample S4 with 170 nm VO₂ film on TiO₂ buffer layer measured at room temperature reveal a typical set of A_g modes characteristic for VO₂ M1 monoclinic lattice with positions at 192, 222, 260, 308, 337, 390, 497 and 614 cm⁻¹ as well as a trace of a monoclinic M2 mode at 600 cm⁻¹ similar to Ref Sample on bare c-Al₂O₃ substrate as shown in Fig. 4 [5]. The absence of modes shift claims that the mechanical stress in lattice of such VO₂ films is minor. The detailed information on the detected vibration modes is summarized in Table 1S of Supplementary.

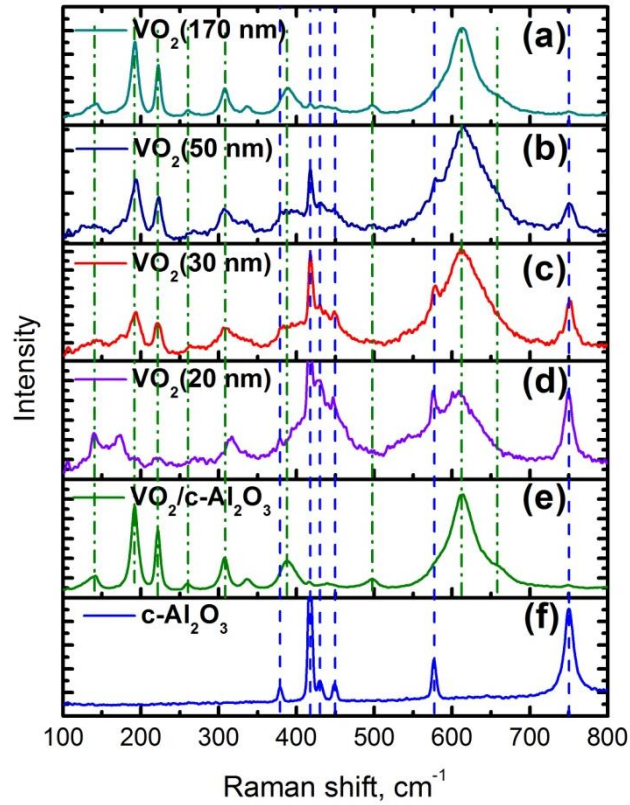

Fig. 4 Raman spectra of VO₂ films with altered thickness: 170 nm (a), 50 nm (b), 30 nm (c), 20 nm (d) deposited on TiO₂-buffered c-Al₂O₃ substrates. Spectra of VO₂ film deposited on bare c-Al₂O₃ without buffer layer (e) and of the bare c-Al₂O₃ substrate (f).

Remarkable that the positions of VO₂ vibration modes are not changed in films when the thickness is decreased to 30 nm. However, in thinner films, in particular when the film thickness is as small as 20 nm, the modes of VO₂ reveal significant shifts which evidences that a great mechanical deformation occurs in the crystal lattice. More specifically, one of the two strong A_g lines near 192 cm⁻¹ and 222 cm⁻¹ is shifted to 173 cm⁻¹, while the other is significantly weakened or is completely disappeared when thickness is decreased. The strong A_g mode at 614 cm⁻¹ is shifted to 608 cm⁻¹. The A_g mode at 308 cm⁻¹ which presumably belongs to the M2 phase of VO₂ is shifted to 317 cm⁻¹. It is notable that the A_g mode at 308 cm⁻¹ for 30 nm and 50 nm films is disappeared with increasing temperature and the peak at 317 cm⁻¹ which we assign to M2 phase is appeared instead. For a 20 nm film this vibration mode is shifted to 317 cm⁻¹ already at room temperature. Also, the A_g mode at 390 cm⁻¹ is shifted to 402 cm⁻¹ in a 20 nm VO₂ film.

Typically, the M2 phase in VO₂ is observed at ~50 °C, i.e. at temperature just below MIT [21]. However, in thin and strained VO₂ film of present study the modes of intermediate M2 phase are detected already at room temperature.

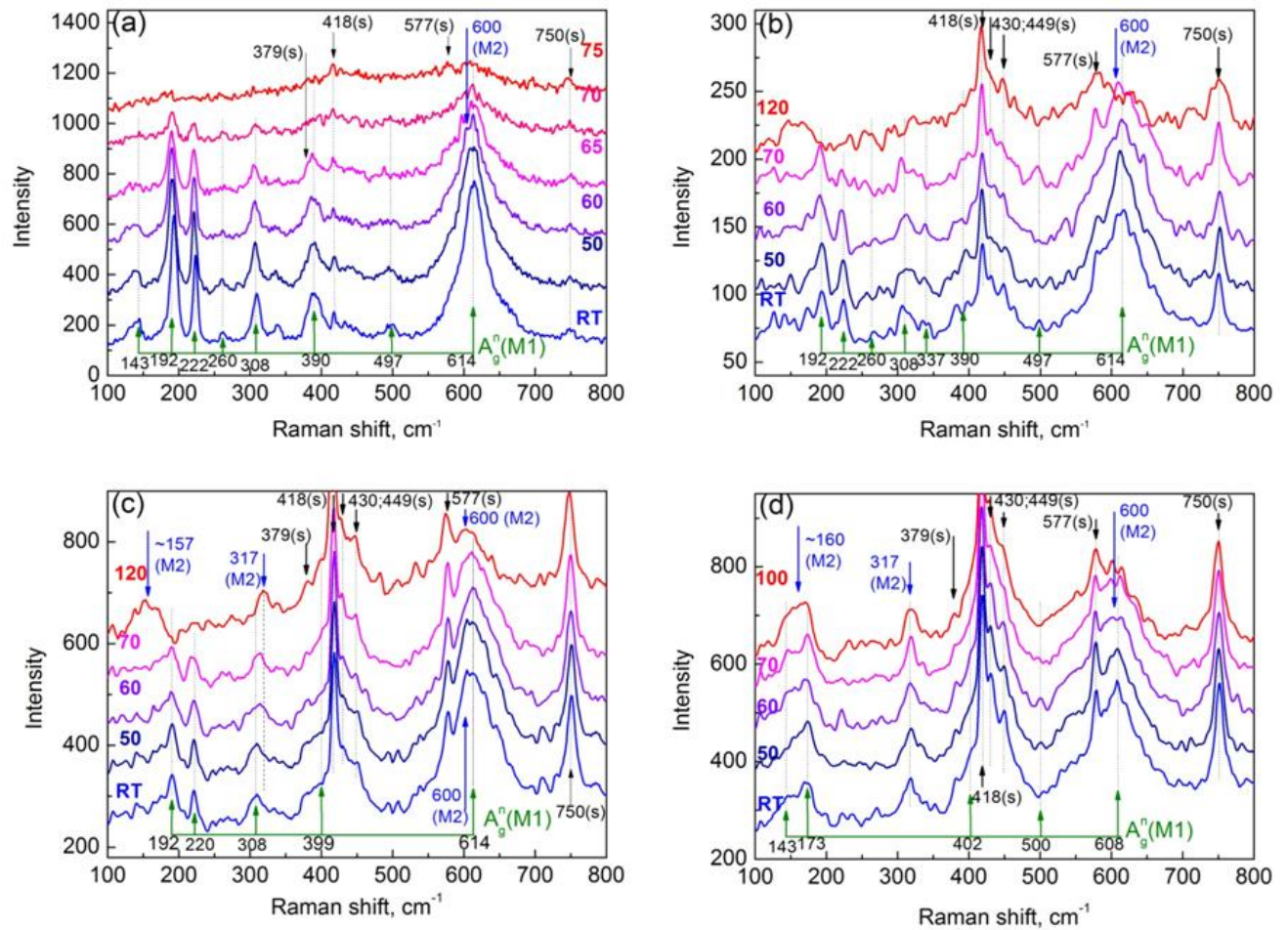

Fig. 5 Raman spectra of VO₂/ TiO₂ films of varied thickness as function of temperature. VO₂ layer thickness is 170 nm (a), 50 nm (b), 30 nm (c), 20 nm (d).

Mechanical strain in VO₂ lattice results in altered electrical hysteresis loop as shown in Fig. 6. Reduction of the thickness results to a decreased range of the resistance alteration. Also, MIT temperature is shifted to higher values. It is remarkable that temperature position of the beginning of hysteresis loop is almost independent of VO₂ thickness. The resistance of samples in semiconductor state also remains almost unchanged. On the other hand, the resistance of samples in the metallic state is altered significantly with thickness decreasing. More specifically, the metallic state resistance of sample S4 with 20 nm VO₂ layer is ~45 times greater at T=90 °C compared to the one of sample S1 with 170 nm film.

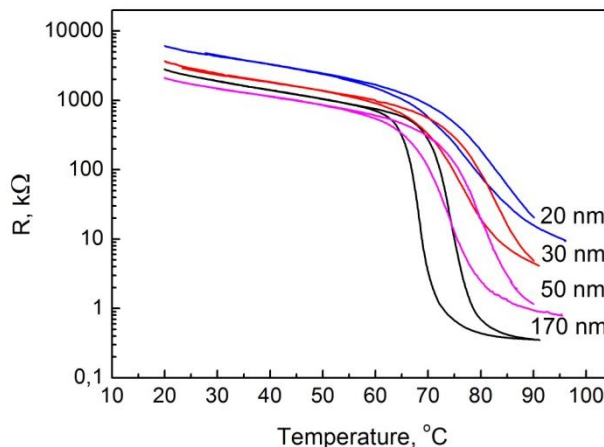

Fig. 6 MIT triggered resistance change as function of temperature for $\text{VO}_2/\text{TiO}_2/c\text{-Al}_2\text{O}_3$ samples with different VO_2 thickness.

More comprehensive analysis of hysteresis loops is done as shown in Fig. 7 for the temperature dependencies of the derivatives $d(\log_{10}(R))/dT$ that are obtained from data in Fig. 6. The detailed characteristics of MIT hysteresis loops for samples S1-S4 are summarized in Table 4. An average phase transition temperature is increased from 71.5 °C for the Sample S4 with 180 nm VO_2 film to 80.7 °C for the Sample S1 with 30nm VO_2 layer. Also, a thickness decrease results in increased hysteresis curve abruptness ΔT . Note, that a hysteresis width ΔH is only slightly altered near 6 °C for all S1-S4 samples. Also, the phase transition temperature in the case of $\text{VO}_2/\text{TiO}_2/c\text{-Al}_2\text{O}_3$ structures shifts to higher temperatures compared to $\text{VO}_2/c\text{-Al}_2\text{O}_3$ structures, while in the case of VO_2 films grown on TiO_2 single crystal a shift to room temperature was observed with decreasing of the VO_2 layer thickness [22].

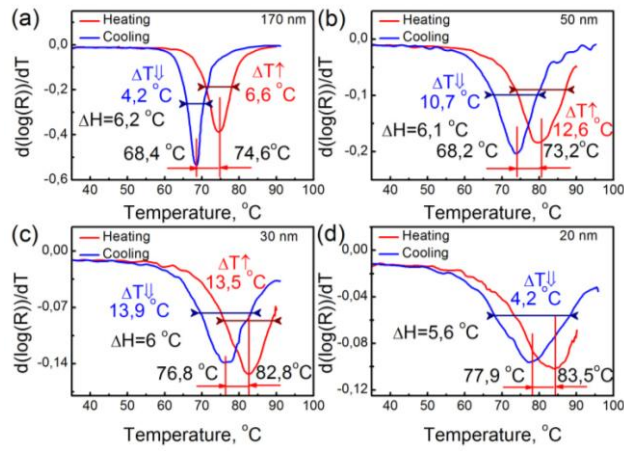

Fig. 7 Temperature dependence of the derivative $d(\log_{10}(R))/dT$ for samples S4 (a), S3 (b), S2 (c) and S4 (d) with different VO_2 layer thickness.

Table 4 Temperature of phase transition T_{PT} , transition abruptness ΔT , hysteresis width ΔH , a minimal resistance R_{min} at temperature above phase transition and resistance alteration ratio R_{ratio}

| Samples | Thickness | T_{PT} (°C) | ΔT (°C) | R_{min} (kΩ) | ΔH (°C) | ΔR_{ratio} |
|---------|-----------|---------------|-----------------|----------------|-----------------|--------------------|
| S1 | 20 | 80,7 | ~20 | 15,8 | 5,6 | $2,7 \times 10^2$ |
| S2 | 30 | 79,8 | 13,7 | 4,5 | 6 | $5,4 \times 10^2$ |
| S3 | 50 | 77,15 | 11,65 | 0,9 | 6,1 | $2,1 \times 10^3$ |
| S4 | 170 | 71,5 | 5,4 | 0,35 | 6,2 | $4,2 \times 10^3$ |

For the transition temperature T_{PT} and transition abruptness ΔT , the given values are averaged data for heating and cooling curves.

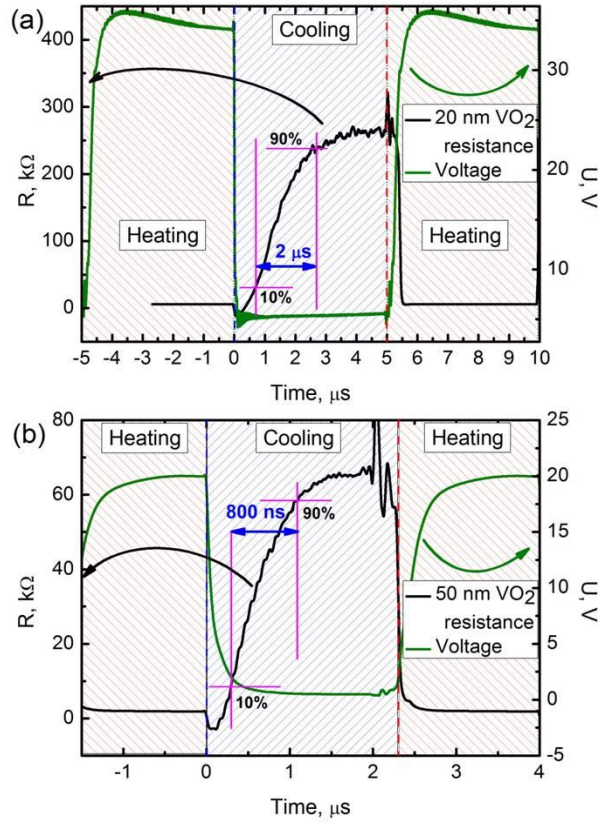

Fig. 8 Electric induced switching of VO₂ films with thickness of 20 nm (a) and 50 nm (b). Voltage applied to the film and corresponding altered film resistance are shown in right and left panels respectively.

Time resolved electric switching characteristics of $5 \times 20 \mu\text{m}$ VO₂ strip fabricated by photolithography from VO₂/TiO₂/c-Al₂O₃ samples S1 and S2 with VO₂ thickness of 20 nm and 50 nm are shown in Fig. 8. Briefly, a pulsed voltage of V_{dd}=27 V at 500 kHz repetition rate was applied to 50 nm thick VO₂. For a 20 nm thick VO₂ device a pulsed voltage of V_{dd}=35 V at 100 kHz repetition rate was applied. The setup used for electric measurement is shown in Fig. 3s of Supplementary material.

The forward and backward switching times were measured as the time required for resistance to be altered between 10% and 90% as shown in Fig. 8. The resistance switching time from insulator to metallic state due to MIT is about 100 ns for both samples S1 and S2. The backward switching time from metallic to insulator state was measured to be 800 ns and 2 μs for sample S2 and S1 with VO₂ thickness of 50 and 20 nm, correspondingly. Indeed, the rate of forward switching is defined by VO₂ heating due to Ohmic losses which is proportional to applied current. In case of backward switching the process of heat dissipation is a key factor that limits switching rate. Thus, it can be expected that thinner films should exhibit shorter backwards switching times. However, in spite of thicker VO₂ layer the S2 sample showed a faster backward switching rate compared to sample S1. Thus, not only the film thickness but also both the VO₂ crystal quality and lattice strain do influence the heat dissipation rate.

The obtained backward switching rates in samples S1 and S2 are slower than value of 252 ns obtained in VO₂ films fabricated on more expensive TiO₂ single crystal [6]. However, it is not clear whether Lee et. al. measured complete phase transition in VO₂ or partial phase transition that is obviously faster. More important, that Lee et al. has also concluded that lattice strain does influence on switching rate. More specifically, significant lattice mismatch between VO₂ and SnO₂ $\sim 4.2\%$ in [6] results in a pronounced strain release on the interface. The strain relaxation is followed by formation of bulk-like VO₂ lattice. The authors claim that forward/ backward switching

times in VO₂/SnO₂/TiO₂ structure are as short as ~36 ns/~74 ns in such relaxed structure. However, such statement is in a controversy with results obtained by Li Z. et al. [23] where much slower electric switching times of 50 ms and 250 ms reported for VO₂/V₂O₅ core-shell nanowire. Indeed, typically a nanowire has much higher crystal quality compared to thin films. However, it was found that nanowire reveal slower switching dynamics compared to its film counterpart [23].

Ultrathin polycrystalline VO₂ films prepared on SiN/Si substrates by depositing metallic vanadium layer with molecular beam epitaxy and further annealing in oxygen [7, 8] should be discussed separately. Such films are fabricated for purposes of near IR waveguide modulators. Being polycrystalline they however reveal fast forward and backward switching rates of 2,43 μs and 6,19 μs correspondingly [24]. Again, we could not discriminate whether these times correspond to complete or partial MIT.

It should be underlined that different optical applications do require different degrees of VO₂ switching. Even minor alterations of dielectric functions in near IR range which correspond to beginning of phase transition can be already successfully used for fast waveguide modulation. On the other hand, noticeable modulation of THz reflection/absorption is occurred only in the last quarter of the VO₂ phase transition just before the metallic state and the switching processes are slower here. The best switching rates obtained to the date are summarized in Table 2 of Supplementary material.

Conclusion

In conclusion, the TiO₂-buffered VO₂ films show MIT transition at elevated temperature of ~71.5 °C (for 170 nm thick VO₂ film) compared to MIT at ~65 °C which is typically observed in VO₂/c-Al₂O₃ films fabricated in similar conditions. The pulsed laser deposition regime for VO₂ films on TiO₂-buffered c-Al₂O₃ substrates at oxygen pressure of 3×10⁻² mbar and temperature of 550 °C was found to be optimal to fabricate films with best MIT related resistance alteration characteristics, namely, with most abrupt MIT, greatest resistance alteration ratio ΔR_{ratio} of 6,7×10³ as well as a narrow hysteresis loop. The fabricated VO₂/TiO₂/c-Al₂O₃ film structures reveal an epitaxial growth with excellent structural properties: co-direction of the [010]VO₂ and [0001]Al₂O₃ axes and [010] VO₂ axis misorientation smaller than 0.5°, better than for VO₂ layer deposited directly on Al₂O₃ substrate. The deposition of VO₂ on Al₂O₃ or on TiO₂/Al₂O₃ is occurred with distortion of the VO₂ unit cell to hexagonal symmetry and the [010] axis of the monoclinic cell of VO₂ becomes a sixth order axis.

Properties of TiO₂-buffered VO₂ films of thickness altered between 170 nm and 20 nm were studied. Composition of VO₂ films has revealed only a minor alteration of VO₂/V₂O₅ phases ratio from 1.6 to 1.8 when the film thickness has been increased from 20 nm to 50 nm and did not change in thicker layers. All the VO₂ films thicker than 30 nm did not show any structural strain. However, 20 nm VO₂ layers have already reveal a great mechanical deformation of crystal lattice. The MIT temperature is increased from 71.5 °C to 80.7 °C when the thickness of VO₂ layer is reduced from 170 nm to 20 nm, however the resistance alteration ratio ΔR_{ratio} is reduced from 4,2×10³ to 2.7×10² in thinner films. The backward electric switching times of VO₂ films were drastically increased from 800 ns to almost 2 μs with VO₂ thickness decrease from 50 nm to 20 nm.

We believe that the obtained results will be highly important when designing VO₂-based active IR/THz metasurfaces and all-optical big data processing systems.

References

1. Z. Ren, J. Xu, J. Liu et al., *ACS Appl. Mater. Interfaces* **14**, 26923–26930 (2022) <https://doi.org/10.1021/acsami.2c04736>
2. F. Hu, Y. Li, X. Xu et al., *Appl. Phys. Express* **11**, 2–7 (2018) <https://doi.org/10.7567/APEX.11.092004>
3. X. Lu, B. Dong, H. Zhu et al., *Nanomaterials* **11**, 1–11 (2021) <https://doi.org/10.3390/nano11123409>
4. J. Guo, T. Wang, H. Zhao et al., *Adv. Opt. Mater.* **7**, 1–7 (2019) <https://doi.org/10.1002/adom.201801696>
5. V. Kaydashev, A. Slavich, I. Domaratskiy et al., *Appl. Opt.* **62**, 4942. (2023) <https://doi.org/10.1364/AO.490081>
6. D. Lee, J. Lee, K. Song et al., *Nano. Lett.* **17**, 5614–5619 (2017) <https://doi.org/10.1021/acs.nanolett.7b02482>
7. L. Sanchez, I. Olivares, J. Parra et al., *Opt. Lett.* **43**, 3650–3653 (2018) <https://doi.org/10.1364/OL.43.003650>
8. J. Parra, T. Ivanova, M. Menghini, P. Homm (2020) [arXiv:2007.11452v1](https://arxiv.org/abs/2007.11452v1)
9. S. He, R. Wang, H. Luo, *Nanophotonics* **11**, 1083–1108 (2022) <https://doi.org/10.1515/nanoph-2021-0823>
10. M. Kim, Y. Jo, C. Lee et al., *Nano. Lett.* **20**, 2733–2740 (2020) <https://doi.org/10.1021/acs.nanolett.0c00358>
11. J. Lu, H. Liu, S. Deng et al., *Nanoscale* **6**, 7619–7627 (2014) <https://doi.org/10.1039/c4nr00898g>
12. Y. Ke, C. Zhou, Y. Zhou et al., *Adv. Funct. Mater.* **28**, 1–18 (2018) <https://doi.org/10.1002/adfm.201800113>
13. T. Yang, C. Hill, N. Carolina et al., *J. Mater. Res.* **25**, 422–426 (2010) <https://doi.org/10.1557/JMR.2010.0059>
14. D. Jung, H. So, J. Ahn et al., *J. Vac. Sci. Technol.* **36**, 102 (2018) <https://doi.org/10.1116/1.5019388>
15. R. Suess, N. Bingham, K. Charipar et al., *Adv. Mater. Interfaces* **4**, 1700810 (2017) <https://doi.org/10.1002/admi.201700810>
16. B. Chen, G. Kim, H. Cho, H. Ohta, *Adv. Electron. Mater.* **8**, 1–7 (2022) <https://doi.org/10.1002/aelm.202100687>
17. M. Nakano, D. Okuyama, K. Shibuya, et al., *Adv. Electron. Mater.* **1**, 1–7 (2015) <https://doi.org/10.1002/aelm.201500093>
18. J. Li, J. Dho, *J. Cryst. Growth* **312**, 3287–3291 (2010) <https://doi.org/10.1016/j.jcrysgro.2010.08.022>
19. E. Breckenfeld, H. Kim, K. Burgess et al., *ACS Appl. Mater. Interfaces* **9**, 1577–1584 (2017) <https://doi.org/10.1021/acsami.6b13112>
20. M. Bayati, R. Molaei, F. Wu, et al., *Acta Mater* **61**, 7805–7815 (2013) <https://doi.org/10.1016/j.actamat.2013.09.019>
21. Y. Sharma, M. Holt., N. Laanait et al., *APL Mater* **7**, 081127 (2019) <https://doi.org/10.1063/1.5115784>

22. L. Fan, S. Chen, Z. Luo et al., *Nano Lett.* **14**, 4036–4043 (2014) <https://doi.org/10.1021/nl501480f>
23. Z. Li, Z. Hu, J. Peng et al., *Adv. Funct. Mater.* **24**, 1821–1830 (2014) <https://doi.org/10.1002/adfm.201302967>
24. J. Parra, T. Ivanova, M. Menghini et al., *J. Light. Technol.* **39**, 2888–2894 (2021) <https://doi.org/10.1109/JLT.2021.3054942>

Statements & Declarations

Funding

The study was supported by the Ministry of Science and Higher Education of the Russian Federation (state assignment in the field of scientific activity FENW-2023-0014). XRD studies are supported by the Southern Scientific Center of the Russian Academy of Sciences under project No. 122020100294-9.

Competing Interests

The authors have no relevant financial or non-financial interests to disclose.

Author Contributions

All authors contributed to the study conception and design. Material preparation, data collection and analysis were performed by M.E. Kutepov, V.E. Kaydashev and E.M. Kaidashev. The first draft of the manuscript was written by M.E. Kutepov and all authors commented on previous versions of the manuscript. All authors read and approved the final manuscript.

Data availability statements

No datasets were generated or analysed during the current study

Supplementary material:

VO₂ films grown on TiO₂ sub-layer: influence of films thickness on structural, electrical and optical properties

M. E. Kutepov^{1,*}, V. E. Kaydashev¹, D.V. Stryukov², A.S. Konstantinov³, A.S. Mikheykin³, A.V. Nikolskiy⁴, A.T. Kozakov⁴, A.D. Morozov⁵ and E. M. Kaidashev¹

¹*I. I. Vorovich Mathematics, Mechanics and Computer Science Institute, Laboratory of Nanomaterials, Southern Federal University, 200/1 Stachki Ave., 344090 Rostov-on-Don, Russia*

²*Federal Research Centre The Southern Scientific Centre of the Russian Academy of Sciences, Chekhov Ave., 41, 344006, Rostov-on-Don, Russia*

³*Physics Faculty, Southern Federal University, 5 Zorge St., 344090 Rostov-on-Don, Russia*

⁴*Institute of Physics, Southern Federal University, 194 Stachki Ave., 344090 Rostov-on-Don, Russia*

⁵*Moscow Institute of Physics and Technology (MIPT), Institutskiy 9, 141701 Dolgoprudny, Russia*

kutepov.max@yandex.ru*

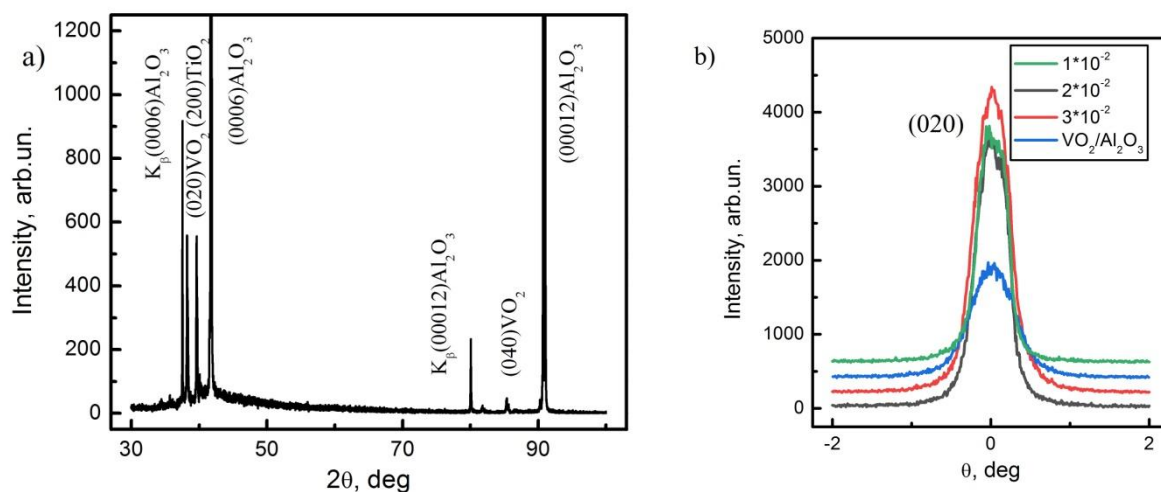
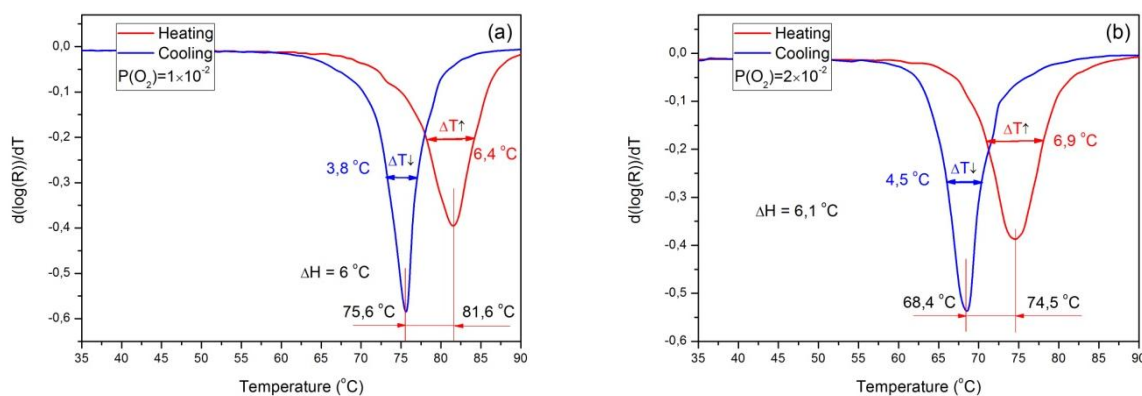

Fig. 1s a) θ - 2θ X-ray diffraction pattern for a VO₂/TiO₂/Al₂O₃(0006) film synthesized at $P(\text{O}_2)=1 \times 10^{-2}$. b) Rocking curves of the VO₂ (020) reflection for VO₂ films obtained at oxygen pressure in $1 \times 10^{-2} - 3 \times 10^{-2}$ range.



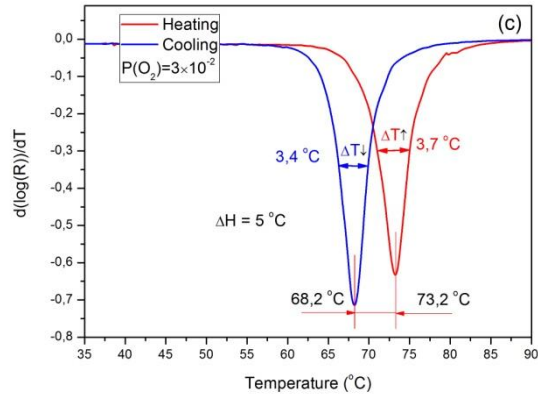

Fig. 2s Derivative of a $\log(R(T))$ dependence of a $\text{VO}_2/\text{TiO}_2/\text{c-Al}_2\text{O}_3$ series of samples synthesized at an oxygen pressure of $(1 - 3) \times 10^{-2}$ for a VO_2 layer (a,b,c) and a VO_2 film.

Table 1s. Positions of Raman active modes of the $\text{VO}_2/\text{TiO}_2/\text{c-Al}_2\text{O}_3$ samples with various VO_2 thickness.

| Laser pulses (thickness) | $\text{VO}_2/\text{c-}$ Al_2O_3 | 4000 (170 nm) | 1200 (50 nm) | 720 (30 nm) | 480 (20nm) |
|---|--|------------------|-----------------|----------------|---------------|
| Modes | Raman shift, cm^{-1} | | | | |
| $A_g \text{VO}_2 + B_{1g} \text{TiO}_2$ rutile | 142 | 143 | 142 | 143 | 143 |
| $M_2 \text{VO}_2$ | | | ~157 | ~157 | ~160 |
| $A_g \text{VO}_2$ | 192 | 192 | 194 | 192 | 173 |
| $A_g \text{VO}_2$ | 222 | 222 | 222 | 222 | 221 |
| $A_g \text{VO}_2$ | 260 | 260 | 268 | 268 | |
| $A_g \text{VO}_2$ | 308 | 308 | 308 | 308 | 317 |
| $A_g \text{VO}_2$ | 337 | 337 | 333 | 337 | 328 |
| <i>Sapphire</i> | 379 | 379 | 379 | 379 | 379 |
| $A_g \text{VO}_2$ | 390 | 392 | 394 | 399 | 402 |
| <i>Sapphire</i> | 417 | 417 | 417 | 417 | 417 |
| <i>Sapphire</i> | 430 | | 430 | 430 | 430 |
| <i>Sapphire</i> | 449 | | 449 | 449 | 449 |
| $A_g \text{VO}_2$ | 497 | 497 | 497 | | 500 |
| <i>Sapphire</i> | 577 | 577 | 577 | 577 | 577 |
| $M_2 \text{VO}_2$ | 600 | 600 | 600 | 600 | 600 |
| $A_g \text{VO}_2$ | 614 | 614 | 614 | 614 | 609 |
| <i>Sapphire</i> | 750 | 750 | 750 | 750 | 750 |

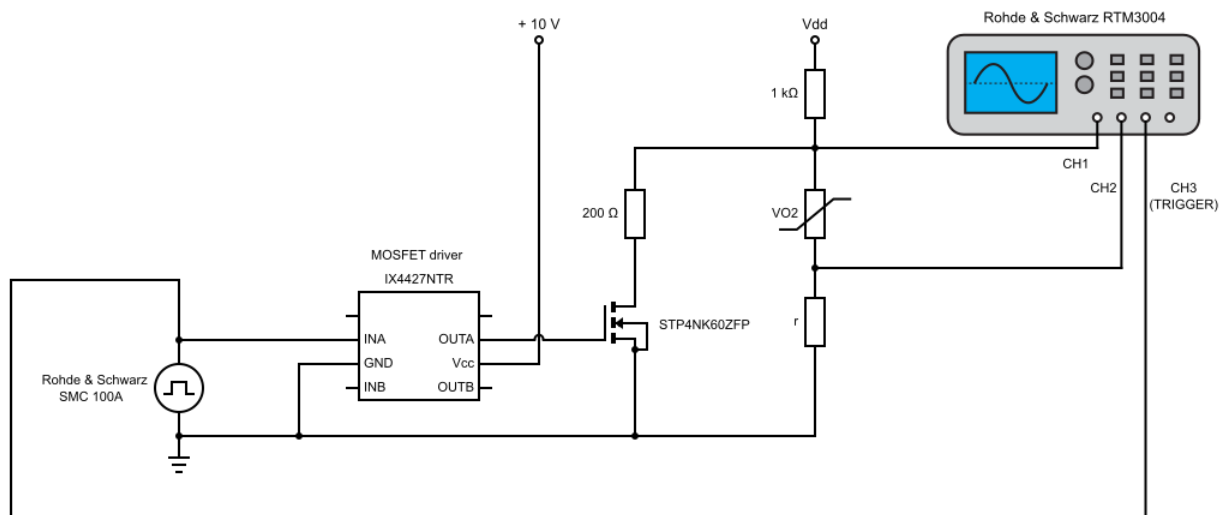

Fig. 3s Electric circuit scheme for measuring the time resolved switching characteristics of $\text{VO}_2/\text{TiO}_2/c\text{-Al}_2\text{O}_3$ samples with VO_2 films thickness of 20 nm and 50 nm. The limiting resistor (r) was chosen to be 9.1 k Ω and 23.2 k Ω for 50 nm and 20 nm VO_2 films correspondingly.

Table 2s.

| Sample | Forward switching time | Reverse switching time | Deposition technique | Reference |
|---|------------------------|------------------------|--------------------------------|---------------|
| VO_2/TiO_2 | 91 ns | 252 ns | PLD | [1] |
| $\text{VO}_2/\text{SnO}_2/\text{TiO}_2$ | 36 ns | 74 ns | PLD | |
| VO_2/Si waveguide | 2.43 μs | 6.19 μs | MBE followed by post annealing | [2] |
| $\text{VO}_2/\text{V}_2\text{O}_5$ core-shell single nanobeam | 50 ms | 250 ms | CVD | [3] |
| $\text{VO}_2(50\text{nm})/\text{SnO}_2/\text{TiO}_2$ | 100 ns | 800 ns | PLD | Current paper |

References

1. D. Lee, J. Lee, K. Song et al., *Nano. Lett.* **17**, 5614–5619 (2017) <https://doi.org/10.1021/acs.nanolett.7b02482>
2. J. Parra, T. Ivanova, M. Menghini et al., *J. Light. Technol.* **39**, 2888–2894 (2021) <https://doi.org/10.1109/JLT.2021.3054942>
3. Z. Li, Z. Hu, J. Peng et al., *Adv. Funct. Mater.* **24**, 1821–1830 (2014) <https://doi.org/10.1002/adfm.201302967>