AI, Climate, and Regulation: From Data Centers to the AI Act

Kai Ebert[†]

European University Viadrina
Frankfurt (Oder), Germany
kebert@europa-uni.de

Nicolas Alder[†]

Hasso Plattner Institute
Potsdam, Germany
nicolas.alder@hpi.de

Ralf Herbrich

Hasso Plattner Institute
Potsdam, Germany
ralf.herbrich@hpi.de

Philipp Hacker

European University Viadrina
Frankfurt (Oder), Germany
hacker@europa-uni.de

Abstract

We live in a world that is experiencing an unprecedented boom of AI applications that increasingly penetrate and enhance all sectors of private and public life, from education, media, medicine, and mobility to the industrial and professional workspace, and—potentially particularly consequentially—robotics. As this world is simultaneously grappling with climate change, the climate and environmental implications of the development and use of AI have become an important subject of public and academic debate. In this paper, we aim to provide guidance on the climate-related regulation for data centers and AI specifically, and discuss how to operationalize these requirements. We also highlight challenges and room for improvement, and make a number of policy proposals to this end. In particular, we propose a specific interpretation of the AI Act to bring reporting on the previously unaddressed energy consumption from AI inferences back into the scope. We also find that the AI Act fails to address indirect greenhouse gas emissions from AI applications. Furthermore, for the purpose of energy consumption reporting, we compare levels of measurement within data centers and recommend measurement at the cumulative server level. We also argue for an interpretation of the AI Act that includes environmental concerns in the mandatory risk assessment (sustainability risk assessment, SIA), and provide guidance on its operationalization. The EU data center regulation proves to be a good first step but requires further development by including binding renewable energy and efficiency targets for data centers. Overall, we make twelve concrete policy proposals, in four main areas: Energy and Environmental Reporting Obligations; Legal and Regulatory Clarifications; Transparency and Accountability Mechanisms; and Future Far-Reaching Measures beyond Transparency.¹

1 Introduction

The environmental consequences of artificial intelligence (AI) are becoming ever more apparent as large models are increasingly trained and deployed across society. This inherently intertwines the digital transformation with questions of climate change, particularly concerning the energy and water consumption of AI models. These features are attracting attention from both the public and academia

[†]Equal contribution.

¹Date of this version: Oct 8, 2024.

[11, 10, 3, 7, 18, 4, 13]. Indeed, as AI is integrated into ever more processes—from economic operations, logistics and employment to administrative and judicial proceedings—agent systems are being deployed, and machine learning is increasingly writing code for robots and steering them in real time, limiting the climate effects of AI throughout the value chain is becoming an ever more pressing societal and regulatory concern.

Starting at the hardware side of the AI value chain, one major, broadly debated component is energy efficiency targets for data centers,² with concerns growing that the supply of renewable energy may not keep up with their increasing demand [1]. Leading companies like Google have already sounded the alarm, noting that rising energy demands from AI may jeopardize their carbon-zero commitments.³

Regulation is likely to play a pivotal role in addressing the collective action problem posed by AI's impact on the climate. Globally, various initiatives are under development to create comprehensive legal frameworks for AI. One of the most notable examples is the EU AI Act, which took effect in early August 2024. This legislation includes substantial provisions aimed at climate considerations, with specific requirements for reporting, risk assessments, and mitigation efforts. Consequently, it is anticipated that AI's environmental footprint will become a critical market factor, influence reputational outcomes, and enable enhanced public scrutiny by stakeholders such as NGOs and analysts. Furthermore, the revised Energy Efficiency Directive, along with the Delegated Regulation, introduces regulatory measures targeting data center operators.

This paper explores the current and proposed regulatory landscape governing data center operators, along with the AI Act's climate-related provisions, from both legal and technical perspectives. Our analysis focuses on three key contributions. First, we identify significant gaps in the AI Act and, to some extent, in the Energy Efficiency Directive. Second, we highlight the operational difficulties in implementing the AI Act's current mandates. Finally, we offer a set of policy recommendations aimed at overcoming these challenges. These reforms extend beyond the scope of the AI Act, referencing broader initiatives such as the recently adopted Global Digital Compact at the United Nations.

2 Technical Background

To lay the ground for the subsequent legal and technical analysis, we start by introducing some core technical aspects of AI models.

From a technical perspective, it is important to distinguish between training, fine-tuning, and inference. Training, on the one hand, refers to the process of initially adjusting a model's parameters or weights to fit the data. This process is highly compute-intensive and typically requires a significant amount of energy [12, 11, 21, 7]. The terms training and pre-training are used interchangeably. The pre-training step involves training an LLM on large-scale data. LLM performance strongly depends on the model scale (number of parameters), which also requires more training data [9, 17]. Therefore, a continuous scaling of the models and thus also of the energy and resource consumption is to be expected, which can also be observed through the continuous publication of new and ever larger models. It is currently not possible to assess when an actual saturation of model performance will occur [19], as evaluation metrics, available data and tasks are also subject to ongoing adaptation and development.

Fine-tuning aims at adjusting a pretrained model to fit more specific data in order to perform better at specific tasks. It is usually performed by retraining specific parts or even the full model. One can also add layers or model architecture components to better account for the new data or task. Overall, fine-tuning follows pre-training and involves a significantly smaller amount of training data and compute budget. The specific procedure for successful fine-tuning is very model-, data-, and task-specific, and rather empirical. Therefore, the computational and energy-intensity can vary significantly for this step. For example, as highlighted by Luccioni et al. [12], the energy usage for fine-tuning the Bloomz-7B required 7,571 kWh compared to 51,686 kWh for the entire training process, adding another 15 % to the initial consumption. Fine-tuning and other related methods enable researchers and companies to make use of large-scale models which would otherwise be prohibitively expensive.

²Further EU legislation is anticipated, following the Commission's report by 15 May 2025 under Art. 12(5) of the Energy Efficiency Directive (EU) 2023/1791.

³Google 2024: Environmental Report.

Inference, on the other hand, refers to the procedure of generating a prediction or output from a trained model based on provided input features or data. In practical applications, models generate inferences during deployment. For example, prompting an LLM constitutes an inference. Typically, an individual inference consumes little energy compared to training; but there are many more inference than training events.

From a hardware perspective, the training and fine-tuning of large models generally requires a distributed arrangement of many servers, each handling subsets of the model and data. Techniques are used to synchronize these distributed components. Presently, the hardware predominantly consists of Nvidia graphics processing unit (GPU)-intensive servers.

Inference in large models is also conducted using GPU-based servers. Although certain models can be accommodated within the memory of a single GPU, inferences for most large models surpass the GPU memory capacity and must also be executed in a distributed manner. It is important to mention that methods like quantization can be employed to lower the computational and memory requirements during inference. This technique involves using model weights at a reduced precision. Also, task-specific models tend to consume less energy than general-purpose models [12]. This demonstrates that energy and hardware requirements are not fixed for the very same task. Given the same performance necessities, more energy-efficient and hardware-efficient models might be, and increasingly become, available.

Research on efficient LLM training and fine-tuning is a growing field with a large variety of approaches involving the full lifecycle of a model. Examples include mixed precision pre-training [8, 17], efficient resource scheduling utilizing thousands of GPUs [15], low-rank adaptation [6], among others [20]. Nevertheless, this research concentrates on computing budget rather than energy efficiency, despite a significant relationship between them.

Energy usage in hardware can be classified into static and dynamic energy [16, 2]. Static energy is the power required to run hardware devices without any specific load (not limited to GPUs). Dynamic energy is consumed when transistors switch their binary states and are electrically charged, driving the predominant portion of power consumption. Typically, fully utilizing hardware devices is more energy-efficient than operating them at lower workloads for extended periods since static energy consumption remains independent of workload.

Most of these computations are conducted in data centers. The power usage effectiveness (PUE) metric reflects the energy efficiency of a data center. It indicates the ratio of the total energy needed by a data center, including components like cooling, to the energy used solely by the computational devices. A PUE of 1.0 would imply ideal efficiency, meaning the data center uses only the energy necessary to power the computational devices. Conversely, a PUE of 1.2 indicates that in order to use 1kWh for computing hardware, the total energy consumption of the data center is 1.2kWh. The average data center PUE in 2023 was 1.58 globally⁴ and 1.6 in the EU⁵.

3 Regulation on Data Centers

Data centers run all kinds of operations, such as cloud computing, crypto currencies and the Internet at large. Recently, AI training and inference have experienced massive growth. Broad data center regulation, therefore, indirectly governs environmental effects of AI and constitutes the backdrop against which specific AI regulation must be viewed. Taking a look at the requirements for data centers can help to find a coherent and effective interpretation of the requirements in the AI Act as it builds on already available data and established methodology.

EU rules stipulate data collection and reporting obligations for data centers (see subsection 3.1) and mandatory energy audits (subsection 3.2). However, they lack binding efficiency and renewable energy targets. Most of these EU rules need national implementation by Member States. Notably, the German implementation goes much further by broadening the scope and putting in place additional requirements, including energy efficiency and renewable energy targets for data centers (subsection 3.3).

⁴Statista

⁵COM Joint Research Centre

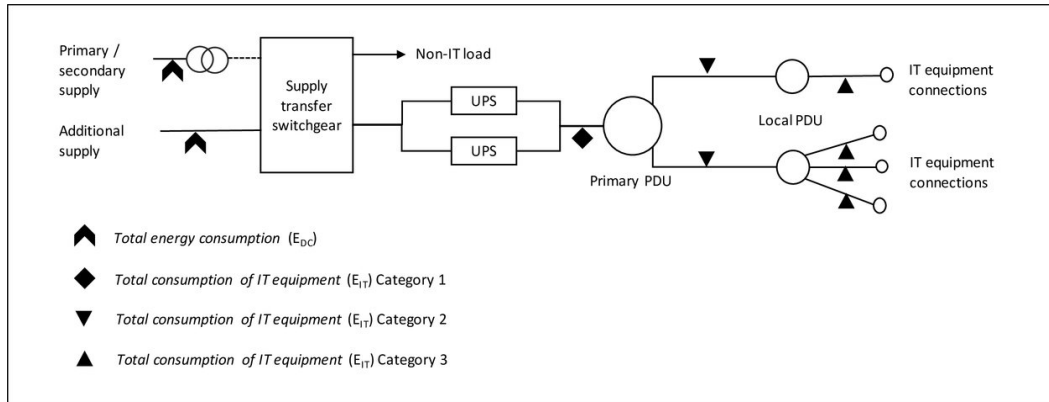

Figure 1: Measuring points for IT equipment energy consumption pursuant to the Delegated Regulation, Annex II

In the U.S., a bill for an AI Environmental Impacts Act was introduced in the Senate, but has not yet been enacted (subsection 3.4). The proposed law takes a very soft approach. It does not suggest any binding rules for the industry, but would commission Federal Agencies to prepare the ground for future industry legislation. Any reporting under the law would be voluntary.

3.1 EU Data Collection and Reporting Obligations for Data Centers

In the EU, data collection and reporting obligations for data centers were established by two recent legal acts, Art. 12 of the recast Energy Efficiency Directive EU/2023/1791 of September 13, 2023 ("EED"), and the Commission Delegated Regulation EU/2024/1364 of March 14, 2024 ("Delegated Regulation"). The new rules apply to all data centers in the EU with a power demand of the installed information technology (IT) of at least 500kW, which includes small-sized data centers. Data center operators are required to collect, make publicly available and report to a EU database information that is deemed relevant for the sustainability assessment of the data centers and the industry as a whole. The reporting is mandated on an annual basis.

The required data includes energy consumption, power utilization, temperature set points, waste heat utilisation, water usage and use of renewable energy (EED, Annex VII(c)). Notably, while the EED focuses on energy and power, the reporting of water usage is a significant step forward as both energy and water consumption have raised concerns in AI settings [10, 12]. In addition, the Water Framework Directive can be harnessed to limit the overall amount water a data center may consume, and also control for any potential loss of water quality [4].

The Delegated Regulation provides specific key performance indicators and methodology. Most notable is the requirement to measure and report the energy consumption of the installed information technology. Following the standard-methodology for the calculation of PUE,⁶ the energy consumption must be measured at the uninterruptible power system (UPS) or, if not existent, at the power distribution unit (PDU) or at another point specified by the data center (see Delegated Regulation, Annex II(1)(e)). These options are depicted in Figure 1 as Categories 1-3.

Prior to the issuance of the Delegated Regulation, the Commission conducted an expert study on the options for a reporting scheme, which the Commission broadly followed.⁷ Even though it might be more accurate to measure the energy consumption closer to the ICT equipment, the study recommends the UPS as a primary measuring point.⁸ Measuring directly at the ICT equipment is deemed impractical because colocation data centers have no direct access to the ICT equipment housed for their customers. Measuring at PDU level is also considered impractical because many data centers do not yet have the equipment to measure energy consumption after the UPS. The UPS is also the easiest point to implement measuring for those who have no measurement in place

⁶The Delegated Regulation refers to the European standard CEN/CENELEC EN 50600-4-2.

⁷European Commission, Reporting requirements on the energy performance and sustainability of data centers for the Energy Efficiency Directive, Task A report: Options for a reporting scheme for data centers.

⁸Ibid, p. 24-25.

yet, at all. Overall, it is deemed good enough to identify data centers with a high energy reduction potential of the supporting infrastructure. The three-tiered approach therefore seems like a pragmatic compromise, taking into account the technical constraints of colocation data center operators, in particular. Measuring at the UPS, or at the PDU alternatively, is not expected to make a significant difference because, typically, no additional energy consuming equipment is interlaced between those two measuring points.

The data centers must report to the EU database directly or via a national reporting scheme, if such a scheme is implemented by the Member State. From the reported data the Commission calculates the data center sustainability indicators which are made publicly available on an aggregate level. They include the power usage effectiveness (PUE), the water usage effectiveness (WUE)⁹, the energy reuse factor (ERF)¹⁰, and the renewable energy factor (REF)¹¹.

While the EED sets reduction targets for the Union and Member State economies as a whole, it lacks efficiency and renewable energy targets specifically for data centers. Pursuant to Art. 12(5) EED the Commission must report to the European Parliament and Council by May 15, 2025 an assessment of the hitherto reported data and legislative proposals for further measures. Proposals are to establish minimum performance standards, including a timeframe, and an assessment of the feasibility of a transition to net-zero emissions in the data center sector.

3.2 Energy Management Systems and Energy Audits

The EED also requires that Member States mandate companies with an average annual energy consumption of more than 10 TJ to conduct an energy audit at least every four years and those with a consumption of more than 85 TJ to implement an energy management system including regular energy audits (Art. 11 EED). This would also apply to operators of data centers. The Directive sets up certain minimum criteria for energy audits (Annex VI EED) and refers to the relevant international or European standards (Recital 80 EED). The legal minimum criteria, however, do not dictate methodology on measurement of energy consumption.

3.3 German 2023 Energy Efficiency Act

In Germany, the Energy Efficiency Act of 8 Nov 2023 implements the EED and establishes a national reporting scheme and additional requirements, including specific efficiency and renewable energy targets for data centers.

The Act broadens the scope of the reporting obligation to include even smaller data centers, upwards of 300 kW (Sec. 13). It also expands the duty to set up an energy management system to data centers and operators of ICT—i.e., customers of colocation data centers—of more than 50 kW (Sec. 12). Most importantly, it sets targets on energy efficiency and renewable energy use, requiring data centers to reach a PUE factor between 1.5 and 1.2 and an ERF of 10% to 20 % depending on their age (Sec. 11) and to run on 50 % renewable energy, increasing that factor to 100% by 1 Jan 2027 (Sec. 11). Lastly, it requires data center operators to inform their customers on an annual basis on the energy consumption directly attributable to them (Sec. 15).

While this implementation goes much further than the EED, it does not provide more detailed methodology. However, the German law may serve as a blueprint for further European regulation for efficiency and renewable energy targets. Especially the obligation to inform customers of their attributable energy consumption may prove an important prerequisite for AI developing companies to optimise energy consumption.

⁹WUE measures the amount of water used in the data center's cooling and other operations relative to the energy consumed by the IT stack.

¹⁰ERF represents the percentage of energy that is reused from a data center's waste energy, showing the efficiency of energy recovery.

¹¹REF indicates the proportion of a data center's energy that comes from renewable sources.

3.4 Bill in the U.S. Senate for a 2024 AI Environmental Impacts Act

On 1 Feb 2024, the bill for an AI Environmental Impacts Act was introduced in the U.S. Senate by Senator Edward J. Markey (D-MA).¹² The bill was referred to the Committee on Commerce, Science and Transportation and there has not yet been a vote.¹³ The future of the bill is therefore unclear.

Even if enacted, it would not contain any significant hard regulation. The bill orders the Environmental Protection Agency (EPA) to conduct a comprehensive study on AI's environmental effects (Sec. 4) and requires the National Institute of Standards and Technology (NIST) to convene a consortium of stakeholders to identify the future measurements, methodologies, standards, and other appropriate needs to measure, report, and mitigate the environmental impacts of artificial intelligence (Sec. 5). It further requires NIST to develop a system for voluntary reporting of environmental impacts of artificial intelligence (Sec. 6). The EPA, NIST and the Department of Energy are to report to Congress on these three measures within four years (Sec. 7).

3.5 Interim Conclusion on Data Center Regulation

The regulation of data centers in the context of AI's environmental impact, particularly regarding energy and water consumption, presents both advantages and shortcomings. The increasing growth of AI-related activities, such as training and inference, places significant pressure on the environmental footprint of data centers. While the EU has implemented generic data center regulations, such as those outlined in the Energy Efficiency Directive and the Delegated Regulation, these rules also indirectly govern the environmental impact of AI by imposing reporting and data collection requirements. Notably, these regulations require the reporting of both energy and water consumption, a critical aspect given the rising concerns over resource use in AI applications.

One of the key strengths of the EU's approach is the establishment of specific reporting obligations. Data center operators must collect and publicly report energy consumption, power utilization, water usage, waste heat utilization, and the use of renewable energy. These measures help create transparency and provide a foundation for future efficiency improvements. Additionally, the German implementation of the EED goes beyond mere reporting by setting specific targets for energy efficiency and renewable energy use in data centers, as well as requiring smaller data centers to comply. Germany's approach might serve as a potential blueprint for broader EU regulation, particularly with its mandates to inform customers about their direct energy consumption, an essential factor for optimizing AI-related energy use.

However, the regulations also present several shortcomings. While data collection and reporting obligations are useful, the absence of binding efficiency and renewable energy targets at the EU level is a major limitation. Although the Commission is expected to propose further legislative measures by 2025, the current lack of enforceable standards means that data centers could continue to consume vast amounts of energy and water without significant reductions in their environmental impact. Moreover, while Germany has introduced stricter targets, these do not extend to all Member States, potentially leading to a fragmented regulatory environment across the EU.

The situation in the U.S. contrasts with the EU approach. While a bill for an AI Environmental Impacts Act was introduced in the Senate, it remains unenacted and proposes only voluntary measures, such as studies and recommendations by federal agencies and institutions (EPA, NIST). The lack of binding rules for data centers in the U.S. means that AI's environmental footprint could grow unchecked unless future legislation introduces more concrete regulatory measures.

4 AI Act: Gaps and Interpretation Challenges

The AI Act applies further down in the value chain, targeting entities that develop and deploy AI systems. After introducing the key terminology used by the Act, we discuss the major climate-related obligations contained in it, with a particular focus on transparency, risk assessment and mitigation. As our analysis shows, the Act makes steps in the right direction, but fall short of a comprehensive regime for tackling climate-related risks of AI models.

¹²US Senate, S.3732 - Artificial Intelligence Environmental Impacts Act of 2024.

¹³Ibid.

4.1 Terminology of the AI Act: AI Models and Systems, Providers and Deployers

The AI Act only applies if an AI model or AI system is used by a specifically designated entity, such as a provider or deployer. The activity also needs to relate to the EU, typically either because the system is offered to persons in the EU or because its output is used in the EU (Art. 2(1) and Recital 22 AI Act).

An AI model, though not explicitly defined in the AI Act, is understood to be a machine learning model that is trained on data and comprised of the parameters and the model architecture (Recital 104). AI models require the addition of further components, such as a user interface, to become AI systems (Recital 97). An AI system, in turn, is defined as a machine-based system 'designed to operate with varying levels of autonomy and that may exhibit adaptiveness after deployment, and that, for explicit or implicit objectives, infers, from the input it receives, how to generate outputs such as predictions, content, recommendations, or decisions that can influence physical or virtual environments' (Art. 3(1)).

Key actors in the AI value chain include providers and deployers. Providers develop or market AI models or systems (Art. 3(3)) while deployers use existing AI systems in a professional capacity (Art. 3(4)). Note that other operationally relevant actors, such as cloud service providers, data providers, data center operators, or other intermediaries are not directly subject to AI Act rules.

The Act pays specific attention to general-purpose AI (GPAI) models, e.g., large language models (LLMs) like GPT-4, that are defined by the wide range of possible uses. Those with the most advanced capabilities, and therefore higher risk of negative effects, are labeled GPAI models with systemic risk (Art. 3(63)-(65)). An AI system that integrates a GPAI model is a general-purpose AI system (Art. 3(66)), e.g. ChatGPT. AI systems used in specific settings subject to product safety regulation, e.g., medical devices, and areas particularly sensitive for public safety or fundamental rights, e.g., law enforcement, migration, education, employment, credit scoring, health or life insurance, are called high-risk AI (HRAI) systems. These systems are subject to other rules, concerning training data, documentation, human in the loop and performance, inter alia (Art. 9-16). When GPAI systems are used in high-risk applications, rules may apply cumulatively (Recital 85, 97).

4.2 Provider or Deployer Status

The AI Act contains energy- and climate-related transparency and risk management obligations, primarily for providers of AI systems or models. Under certain conditions, however, deployers turn into providers, which triggers much more onerous duties, also with respect to climate impacts. Hence, there is a palpable incentive for companies to avoid provider status.

Concerning HRAI systems, pursuant to Art. 25(1), deployers can become providers if they market an existing HRAI system under their name or trademark, substantially modify an HRAI system or change the intended purpose of a non-high-risk AI system such that it falls under one of the high-risk sectors (e.g., employment; life- or health insurance; education). Specifically, if a deployer uses a GPAI system, such as ChatGPT, in a high-risk setting, for example by harnessing it for resume screening in hiring, they automatically assume the responsibilities of a provider of a HRAI system (Art. 25(1)(c)).

An existing HRAI system can be altered. If the modification is substantial, the modifying entity becomes a new provider (Article 25(1)(b)). It is unclear, however, what precisely constitutes a "substantial modification" that would trigger provider status for the modifying entity. A formal interpretation suggests that any change to the model could be deemed substantial, based on Art. 3(23), which defines substantial modification as any unplanned change affecting compliance or intended purpose. On the other hand, a—more convincing—material interpretation would claim that provider status should only apply if the modification increases the model's risk in a nonnegligible way. This aligns with the AI Act's focus on risk mitigation, and also the language in Article 3(23) according to which any significant modification must affect compliance with the high-risk rules of the Act (or change the purpose).

For GPAI models, Recitals 97, 109, and 111 suggest that any entity performing even minimal fine-tuning of a GPAI model is automatically classified as the provider of a new model, including all associated responsibilities [1]. For minor modifications this is disproportionate, even if Recital 109 states that obligations are limited to the fine-tuning itself [1]. A solution could be an analogy with

Article 25(1)(b) so that provider status would only be triggered by a *substantial* modification made through fine-tuning, rather than any minor changes [1]. This is particularly important for SMEs using powerful models (GPAI models with systemic risk): if they become providers, they need to comply with the much more stringent obligations in Article 55 concerning evaluation and risk management, red teaming, incident reporting and cybersecurity.

4.3 Transparency

The first climate-related obligation in the AI Act concerns transparency and reporting, but not with respect to data centers, but concerning providers of high-risk and GPAI models [1].

However, the rules come with significant ambiguities and loopholes. In the following, we detail the six most important ones.

1) For high-risk AI systems, pursuant to Article 11(1) providers must document the computational resources utilized during the development, training, testing, and validation stages, as outlined in Annex IV(2) which does, however, not include the energy consumption directly [1]. This omission hinders the capacity to evaluate and compare the environmental impact of such systems accurately. As a result, the environmental footprint must be estimated indirectly based on the recorded computational resources.

2) The AI Act requires providers of general-purpose AI models to meet transparency obligations. Article 53(1)(a) mandates that providers maintain up-to-date technical documentation, including the details outlined in Annex XI. This annex requires the reporting of energy consumption, whether known or estimated, while estimates may be based on the computational resources used. However, this requirement exhibits a significant gap as it only covers the energy used during the model's development phase, but leaves out the inference phase [1]. Recent research has shown that energy consumption during inference often exceeds that of the development phase very significantly over time [12, 21].

Although (pre-)training is the most noticeable driver of power consumption, the total energy usage by inferences becomes more significant in the long run when considering overall energy consumption. Eventually, the training of extensive LLMs will likely reach a point of saturation, though the specific timeline is uncertain and will depend on achieving adequate model performance or other factors like energy costs or data availability. Presently, convergence and subsequent training costs grow significantly with increasing model sizes. Nevertheless, once models are predominantly deployed and utilized in products, the energy consumption from inferences will rapidly surpass that of the initial model training phase. Although we are not aware of official numbers, this effect is likely to be already relevant for heavily utilized models such as those available by OpenAI's ChatGPT.

In Luccioni et al. [12], the energy usage for inference in various large language models (Bloom) was assessed. They found that it takes between 200 and 500 million inferences, depending on the model's size, for the total energy consumed by inferences to equate to the energy required for initial training. The necessity of incorporating inference energy consumption into mandatory reporting is underscored by Meta's reported carbon emissions for various deployed AI models [21]. While (most of) these models are not LLMs, they demonstrate that the power consumption and associated carbon emissions from inferences greatly exceeds that from training in production. There is a significant amount of ongoing research focused on optimizing the efficiency of training and inference for large-scale models. Implementing a reporting for inferences would create an incentive to balance not only performance and cost considerations but also explicitly focus on a reduced power consumption. Furthermore, obtaining information on the energy consumption of the cumulative inferences would additionally require the inclusion of model deployers and actually performed inference computations into the reporting obligations.

To bridge this gap, we propose an alternative interpretation, based on the information provided to downstream actors (see also [1]). As a result of the AI Act, providers must supply downstream developers and relevant authorities with technical information on how to incorporate GPAI models into AI systems (Articles 53(1)(a) and (b), together with Annex XI and Annex XII). While energy consumption is not explicitly referenced in these provisions, they could reasonably be understood to include details about the computational resources required for inference. This would enable downstream providers to allocate resources more effectively and indirectly promote transparency around the energy consumption involved in each individual inference. However, to calculate the

overall energy consumption for inferences, the total number of inferences would need to be available as well. While the typical energy costs of inferences should therefore be mandatorily disclosed by providers, deployers should be compelled to divulge information on the number of inferences, e.g., on an aggregate monthly level.

3) Open-source (OS) GPAI models are largely excluded from transparency requirements unless they present a systemic risk, as outlined in Articles 2(12) and 53(2) [1]. The idea is that OS models, by definition, already disclose certain types of information. Hence, Recital 102 lists information on parameters, including weights, model architecture, and model usage as a prerequisite for systems to be considered OS. However, it does not mandate the disclosure of energy consumption. This results in an unwarranted lack of visibility concerning the environmental impact and energy usage of these models.

4) Where the Act does mandate the disclosure of energy consumption, this information is restricted to authorities and is not accessible to downstream providers (unless the proposed interpretation from 2) is applied) or the general public, due to confidentiality clauses in Articles 21(3), 53(7), and 78(1) [1]. The limited availability of this data significantly reduces transparency and accountability, thereby weakening the potential for public oversight and market responses.

5) The AI Act fails to address the greenhouse gas (GHG) emissions generated by AI applications, for instance in sectors like oil and gas exploration [7, 1]. For example, a recent investigation has revealed Microsoft's aggressive pitch of its AI models to ExxonMobile to optimize fossil fuel exploration.¹⁴ Leaving such applications with significant climate effects out of scope creates a notable reporting gap.

6) The Act also neglects to address the substantial water consumption, a key concern in data center operations [1]. While the Energy Efficiency Directive mandates reporting of water consumption for data centers, the AI Act requires no such reporting specifically for AI—as it does for energy use—nor does it cover operations outside the EU.

4.4 Environmental Risk Assessment and Mitigation

In tackling the climate effects of AI and ICT more generally, is arguably crucial to move beyond mere transparency provisions towards more substantive goals and obligations. Indeed, the AI Act does contain some language to this effect. For providers of GPAI models with systemic risk and providers of HRAI systems, the Act mandates risk assessment and mitigation. We argue that these measures should also consider environmental risks.

Pursuant to Art. 55(1)(b), providers of GPAI models with systemic risk must assess and mitigate possible systemic risks at Union level, including their sources, that may stem from the development, the placing on the market, or the use of the model. Systemic risk is defined as a risk that is specific to the high-impact capabilities of GPAI models and includes negative effects on public health, safety, public security and fundamental rights (Art. 3(65)).

Similarly, according to Art. 9, providers of HRAI systems have to establish a risk management system that identifies and manages the risks to health, safety or fundamental rights when the HRAI system is used in accordance with its intended purpose. For HRAI systems, the assessment and mitigation is limited to the risks that stem from the use, excluding risks in the development phase.

Crucially, both provisions relate to risks of the AI model or system to fundamental rights which, within the AI Act, must be interpreted as including environmental risks [5]. In Art. 1(1) and Recital 1, the purpose of the AI Act is defined as protecting health, safety, fundamental rights enshrined in the Charter, including democracy, the rule of law and environmental protection. However, in the doctrine of the Charter of Fundamental Rights of the European Union (the Charter), environmental protection (Art. 37 of the Charta) is merely an objective rule, not a fundamental right [14]. Democracy and the rule of law are not enshrined in a particular Article of the Charta but serve as guiding principles that permeate the Charta and all of the fundamental rights. Accordingly, they (only) find mention in the preamble of the Charta.

¹⁴Hao, Microsoft's Hypocrisy on AI, The Atlantic, Sept. 13, 2024, <https://www.theatlantic.com/technology/archive/2024/09/microsoft-ai-oil-contracts/679804/>

In our view, the European legislator did not err on the doctrinal classification of democracy, the rule of law and environmental protection in the Charta by including these principles. While it is conceivable that a legislative error may have occurred miscategorising the objective rule in Art. 37 of the Charta, that seems very unlikely for the basic principles merely expressed in the preamble. Instead, the preferred interpretation is that, for the purposes of the AI Act, the legislator meant for these principles to be included whenever the Act refers to fundamental rights. It is, besides, not uncommon for a legal term to have different meanings in different legal settings.

In addition, the provisions on risk assessment and mitigation form a centerpiece of the protective measures included in the AI Act. Without including environmental risks in the risk assessment and mitigation, in effect, not much consideration for environmental risks would remain and certainly not the "high level of protection" that Art. 1(1) mandates.

As a caveat, it should be noted that, while the AI Act requires climate risk assessment and mitigation, no detailed reporting is mandated. For HRAI systems the documentation must comprise a detailed *description* of the risk management system, but not the risk assessment or its results (Annex IV(5)). Providers of GPAI models with systemic risk may rely on codes of practice or European harmonised standards, both of which are not yet available, or alternative means of compliance for assessment by the Commission (Art. 55(2)). If these will entail a detailed reporting of the risk assessment, and to whom, is yet to be determined.

4.5 Interim Conclusion on the AI Act

Overall, while the AI Act introduces valuable steps toward addressing climate-related concerns in AI development and deployment, it falls short of establishing a comprehensive framework for mitigating the environmental risks posed by AI systems. Key provisions on transparency and risk management for high-risk AI and general-purpose AI systems make some progress in requiring documentation of computational resources and energy consumption, but significant gaps remain. For example, the Act does not mandate the disclosure of energy consumption during the inference phase, a crucial omission given the long-term environmental impact of AI applications. Moreover, transparency measures are restricted to authorities, limiting broader accountability and public scrutiny.

Additionally, while the Act imposes risk assessment and mitigation obligations on providers of HRAI systems and GPAI models with systemic risk, these provisions lack sufficient emphasis on environmental factors. Although environmental protection is included in the Act's objectives, its practical integration into risk management remains unclear, and no detailed reporting on mitigation efforts concerning environmental risks is currently required. Without stronger enforcement and clearer guidance, particularly on the inclusion of energy consumption and other environmental impacts in risk assessments, the Act's potential to address the growing climate-related risks of AI systems will remain limited.

5 Operationalizing the Requirements

5.1 Model Providers and their Access to Infrastructure

Leading model providers leverage extensive supercomputer networks equipped with high-performance GPUs for training and inference. This primary group is most impacted by energy consumption reporting. We assume that they possess privileged access or considerable influence over the utilized infrastructure given their financial power or strategic value (e.g., OpenAI, Microsoft, or Nvidia). One can distinguish between companies that develop closed models (e.g., OpenAI) and those that create open-source models (e.g., Meta).

Startups and smaller companies are expected to either directly deploy such models, use available API services of leading model providers, or fine-tune existing models. Although these companies do not typically pretrain large models themselves, they must report energy consumption for fine-tuning—under our proposed interpretation only if the fine-tuning of a model leads to a substantial modification. While this scenario may not be common, it is crucial to establish a regulatory framework for companies that lack the extensive resources of heavily funded, predominantly US-based firms. These smaller entities are likely to rely on cloud services like Amazon's AWS or Microsoft Azure and have limited control over the available product offerings, making them dependent on whether these services provide energy consumption reporting.

5.2 Levels for Measuring and Estimating Energy Consumption

There are several levels within a data center based on which energy consumption may be measured or estimated [1]. These include (1) the data center level, (2) the cumulative server level, (3) the GPU-Level and other hardware within a server and (4) various other levels. In this section, we outline these levels along with their benefits, drawbacks, and estimation methods.

5.2.1 Data Center Level

On the data center level, the power required to operate the entire data center is measured, including both the direct power consumption of computing equipment and the additional overhead for cooling and maintaining the data center.

This approach provides the most extensive and complete figures since it represents the actual energy usage, but also assumes that a data center is exclusively utilized for the pre-training by the model provider. It encourages the selection of an efficient data center. Additionally, data centers have average PUE values of 1.58, so this overhead makes up a significant portion of the energy consumption. On the other hand, the power usage resulting solely from the model's architecture, the quantity of training data, the efficiency of the implementation, and experimental settings is very important, but is somewhat skewed by the efficiency of the data center.

If data-center level power consumption measurement is not available, using the PUE factor for estimation is deemed appropriate. To calculate total energy usage, the PUE factor is multiplied by the raw computational power consumption measured or estimated at the cumulative server or rack level (see below). This might be reasonable, if only parts of a data center are utilized and only measurements closer to the ICT equipment are available.

5.2.2 Cumulative Server Level

A large-scale model is trained across many servers in a distributed manner. Each server includes one or more GPUs responsible for the primary computation. To accurately monitor the power consumption over time, a local power distribution unit (PDU), capable of measuring the provided power, is attached to each server. Aggregating these measurements yields a highly precise figure of the total energy consumption attributable to the model's computations. Instead of manually aggregating local PDUs, the usage of primary PDUs or uninterruptible power supply (UPS) systems already measuring at the rack level or even many racks is also suitable (cf. Figure 1, as long as the measurements precisely match fully the utilized hardware resources by the model providers. The goal is to include all ICT-related power consumption but exclude data center specific efficiency properties.

The upside of this method is that it is extremely accurate and highly correlates with model size or structure, data quantity, and hardware-aware software implementation. It is also widely recognized in the industry for assessing power consumption in data centers. According to a 2023 Green Grid industry survey¹⁵, 66% of data centers can track power demand at least on rack-level. Roughly one third of overall data centers (Europe: 29%, Global: 32%) are already able to collect average utilization and power demand data for individual servers and storage equipment and match this data to their IT equipment inventory.¹⁶ We assume that the data centers that are used for training by large model providers are already able to track this information given its high cost relevance.

However, a significant number of overall data centers do not currently track power demand or are able to do so. Surveyed data center professionals (see Green Grid survey) project implementation of a data management system able to collect power demand data for individual servers and storage equipment and matching data to the IT equipment inventory to require between 3-6 months (Europe: 15%, Global: 19%), 1 year (Europe: 29%, Global: 28%), 2 years (Europe: 12%, Global: 10%), 3 years (Europe: 4%, Global: 4%) or more than 4 years (Europe: 11%, Global: 8%).¹⁷ For European data centers these numbers stand in (surprising) contrast to the obligation under the EED and Delegated Regulation to provide energy consumption data by Sep 15, 2024 (Art. 3(1) and Annex II(1)(e) Delegated Regulation). Either a substantial number of the participants was unaware of the obligations;

¹⁵Green Grid Survey, July 2023 Green Grid is a non-profit industry consortium concerned with the resource efficiency of data centers.

¹⁶Ibid.

¹⁷Ibid.

or thereby acknowledge their inability to comply in time; or the question was too narrow, being pointed at individual servers, while the EED also allows measurement at the higher-level UPS.

An estimation is possible when GPU hours and the associated hardware used are known. By multiplying a GPU-hour with the peak utilization power consumption specified by the manufacturer, one can estimate the upper limit of energy consumption at the server level. This upper bound is typically higher than the actual consumption, as GPU utilization rarely reaches its theoretical peak due to other resource constraints. Higher GPU efficiency means that the same operations are completed in less time, reducing the overhead from non-utilization-dependent hardware power consumption.

5.2.3 GPU-Level and other hardware within a server

The measurement may also be based on the energy usage of particular components within a server as determined by on-chip sensors. Nvidia GPUs and certain CPUs already provide straightforward and user-friendly power consumption monitoring. However, despite GPU power consumption being a significant factor and its usage likely correlating with the total power usage, it substantially under-represents the actual energy consumption since it measures just a single component. CPU power usage is a relatively minor factor in energy consumption during model training. Most other server components cannot be measured. Therefore, we do not advocate for using GPU-level or other component-based power consumption tracking as a suitable method for measuring overall energy usage.

Estimations are not necessary since Nvidia offers an interface for power consumption measurements via sensors. Components that lack sensor interfaces, estimations come with significant uncertainties and assumptions. Therefore, we do not advocate for estimations at this level.

5.2.4 Other levels

Other measurement levels, such as Workload, Cloud Instance, or Virtual Machine, involve high complexity and numerous assumptions, resulting in a lack of standardized measurement or estimation methods with considerable uncertainty. Additionally, these granular levels are unsuitable for power consumption measurements in extensive distributed LLM training. Therefore, we advise against using these levels for power consumption tracking.

5.2.5 Interim Conclusion on the Level of Measurement

In our analysis, we argue that energy consumption should be measured and reported at the cumulative server level [1]. This approach captures the total computation-related power usage and is better suited to help providers optimize their AI models and algorithms for energy efficiency. Additionally, the PUE factor of each data center, which is reported and published by the data center operator under the Energy Efficiency Directive (EU) 2023/1791 and Delegated Regulation (EU) 2024/1364, provides a useful estimate of overall energy consumption [1]. With these two figures, it is possible to distinguish between model-specific power usage (server-level computation) and the data center's efficiency, offering a clearer picture of the total energy investment [1]. Although the EED mandates that PUE factors must be available for data centers situated within the EU, the responsibility of reporting these factors should also fall on the model provider. Specifically, model providers utilizing data center facilities outside the EU should not be granted an exemption.

Estimates of server-level power consumption should be based on peak utilization figures provided by the hardware manufacturer (e.g., Nvidia) [1]. Still, it is important to consider advancements in research. Interpretation of the legal requirements could accommodate justifiable alternative assumptions that may not require peak utilization figures. For instance, tracking GPU utilization through interfaces like those provided by Nvidia and referencing hardware benchmarks based on specific GPU utilization rates could serve as a basis for such assumptions.

5.3 Measurement or Estimation

Although actual measurement is more onerous, it also yields more precise results for energy consumption reporting. Major model providers are likely to already measure power consumption as it is a primary cost factor and highly linked to computational power. Despite the availability of power consumption data, companies may be tempted to use estimated values to protect sensitive information.

This practice should be restricted by legally prioritizing measurements over estimations. Currently, the AI Act only states, ambivalently: "known or estimated energy consumption of the model [...] where the energy consumption of the model is unknown, the energy consumption may be based on information about computational resources used" (Annex XI Section 1(2)(e)).

The same reasoning applies to smaller entities relying on cloud computing services for fine-tuning, for example such offered by Amazon Web Services or Microsoft Azure. Fine-tuning is crucial for employing foundational models in task-specific applications and tailoring them to specific datasets. The higher the expense of initial model trainings, the stronger the incentive to perform fine-tuning rather than retraining the model. Therefore, this is the type of adaptation that most businesses will focus on to effectively integrate large AI models into practical products.

While we assume that cloud platforms already have capabilities to track power consumption, they still lack client-oriented power consumption reporting as part of their products. It is essential that ordinary companies with limited resources do not face obstacles in fulfilling their reporting obligations only because their cloud computing providers do not offer this data. The access rights enshrined in Art. 25(2) AI Act can help if the deploying entity becomes a provider - but providers may invoke trade secrets and IP rights to dilute this obligation (Art. 25(5) AI Act). In our view, the interests of downstream actors in reporting correct figures should generally trump the secrecy interests of upstream providers, in this case.

Under the current setup, companies could always resort to computation-based estimations for their reporting. However, in order to gain the most accurate data, cloud platforms should be incentivized to provide energy consumption data to their clients. Complementing Art. 25(2) AI Act, the obligation established in Sec. 15 of the German Energy Efficiency Act, requiring data centers to inform customers on their attributable annual energy consumption, could serve as a blueprint. Notably, such a law could also apply to cloud service providers based outside the EU, with the caveat, however, that such an extraterritorial application oftentimes lacks enforcement capabilities.

5.4 Sustainability Impact Assessments

The operationalization of sustainability impact assessments (SIAs) within the risk assessments required under the AI Act involves integrating environmental considerations into the existing risk management frameworks that high-risk AI model providers and GPAI providers must follow.

Much like data protection or algorithmic impact assessments, SIAs would serve as a practical tool for embedding climate considerations into the development and deployment of AI systems. Importantly, these assessments should not be limited to high-risk AI models but should also apply to all AI systems, regardless of the associated risk to health or safety. This is because the carbon footprint of AI models is often unrelated to their classification as high or low risk under the Act. Therefore, an SIA could ensure that environmental impacts are considered across the entire AI landscape.

The SIA should involve evaluating various models and design choices during the development process, comparing them not only on their performance but also on their estimated environmental impact. For instance, developers would need to assess whether a simpler model, like linear regression or even a non-AI model, could achieve similar results with a smaller carbon footprint compared to more complex models like deep learning [7]. Similarly, the decision to use large, pre-trained models or training new, narrow models (almost) from scratch should factor in the potential climate benefits. By using existing tools to measure the carbon impact of AI models, developers would be required to opt for the more environmentally sustainable option when performance is comparable. This approach would not only encourage environmental awareness but could also lead to synergies where sustainability and cost effectiveness align.

To effectively implement sustainability impact assessments, providers would need to establish standardized methodologies for measuring the environmental effects of AI models, particularly energy and water usage during training and inference phases. These methodologies should be aligned with existing metrics such as Power Usage Effectiveness (PUE), Water Usage Effectiveness (WUE), and Renewable Energy Factor (REF). This would allow for consistent and comparable between providers and reporting across the value chain. Providers must also be required to report on their use of renewable energy and efforts to mitigate the environmental impacts of their operations. The operationalization process would involve both the collection of real-time environmental data and

the application of predictive models to estimate the long-term sustainability impact of deploying AI systems at scale.

Taking one step back, the concept of "data protection by design" should be expanded to include "sustainability by design," under which developers should actively seek to reduce the contribution of ICT, including AI, to climate change [4]. At both the technical and organizational levels, this would involve adopting all feasible measures to limit environmental impact, a shift that has already been applied in other industries through consumption practices and product design. These approaches are also gaining traction in supply chain management and other sectors in pursuit of corporate Environmental, Social, and Governance (ESG) objectives. By drawing on these existing practices, sustainability by design could become a core principle guiding the regulation of the ICT and AI sectors.

6 Policy Proposals

Although the AI Act attempts to address climate concerns through various reporting obligations, these measures largely lack consistency and clarity. We identify twelve policy recommendations that should be integrated into the evaluation report due in August 2028 (Article 111(6)), as well as any interpretive guidelines from the AI Office and other agencies, and in reviews and potential textual revisions prior to that date [1]. These measures can be grouped in four categories: Energy and Environmental Reporting Obligations; Legal and Regulatory Clarifications; Transparency and Accountability Mechanisms; and Future Far-Reaching Measures beyond Transparency.

6.1 Energy and Environmental Reporting Obligations

The current AI Act overlooks key environmental factors related to AI systems [13]. The following proposals address this gap:

- **Inclusion of Energy Consumption From Inferences:** We propose an interpretation that would at least bring energy consumption for single inferences back into the scope [1]. Adoption of this interpretation by courts, authorities and industry, however, is uncertain. Therefore, both single and overall inferences should be included as a reporting category in Annex XI and Annex XII (vis-à-vis authorities and downstream providers) through delegated acts from the Commission (Articles 53(5) and (6)) and future recommendations from the AI Office.
- **Indirect Emissions and Water Consumption Reporting:** The Act currently omits indirect emissions from AI applications (e.g., those used for oil and gas exploration [7]) and water consumption [10]. Reporting should include:
 - Providers reporting water usage, and
 - Deployers reporting application-related emissions, allowing for estimates where precise measurements are impossible, particularly when dealing with future scenarios.
- **Energy Reporting at the Cumulative Server Level:** Energy consumption should be reported at the cumulative server level[1]. In this endeavor, estimations may be used only when direct measurements are unavailable. These principles should guide the development of technical standards under Article 40 of the AI Act, as well as the potential implementation of the Global Digital Compact on a global scale.

Overall, these proposals aim to ensure comprehensive energy and environmental accountability for AI systems, both for development and inference phases.

6.2 Legal and Regulatory Clarifications on AI Models and Providers

Ambiguities in the AI Act regarding provider responsibilities for AI models need to be clarified to ensure that entities know when and what to comply with. The following proposals address these uncertainties:

- **Clarifying Provider Status for Model Modifications:** The current definition of provider status needs to focus on substantial modifications to AI models, specifically those that

involve changing the model's weights. Reporting obligations and the change-of-provider threshold should be tied to computational costs incurred during significant modifications, with a minimum computational cost threshold ensuring that only energy-intensive changes trigger additional reporting [1].

- **Elimination of the Open-Source Exemption:** The open-source exemption from reporting obligations should be removed, as making parts of a model public does not justify exclusion from environmental accountability [1]. Open-source models can have significant energy implications and should adhere to the same reporting standards as proprietary models.
- **Energy Efficiency and Renewable Energy Targets for Data Centers:** The EED and Delegated Regulation should be amended in three regards, following the German Energy Efficiency Act: they should set binding efficiency targets (PUE) and renewable energy targets for data centers; and include an information obligation for data center operators and cloud service providers vis-à-vis their customers regarding the attributable energy consumption. These measures should be included in the 2025 evaluation report. This would both increase transparency and facilitate more sustainable decisions by market participants.

Overall, these clarifications seek ensure that companies understand their obligations, that open-source models are on par with closed models, and that the regulatory framework sets effective incentives at the source (data centers) to mitigate the environmental impact of AI model development and deployment.

6.3 Transparency and Accountability Mechanisms

To promote public trust and accountability in AI's environmental impact, the following measures are recommended:

- **Public Access to Climate-Related Disclosures:** All climate-related disclosures, including energy consumption, should be made accessible to the general public [1]. If only aggregate data are shared, trade secrets can be protected while allowing for public scrutiny by analysts, academics, and NGOs. Public transparency would drive market pressure, reputational incentives, and public accountability; it would, arguably, encourage companies to reduce their environmental impact.
- **Energy Reporting for High-Risk AI (HRAI):** For High-Risk AI (HRAI) systems, the Act should require the disclosure of energy consumption rather than computational resources to eliminate inaccuracies and enhance comparability.
- **Environmental Risk Assessments:** Providers should be required to include environmental risks in their risk assessments. The language in Art. 1(1) and Recital 1, as well as Art. 9 and 55 AI Act should be clarified to reflect this. This will ensure that environmental impacts are systematically evaluated alongside other risks during AI system development and deployment.

These transparency mechanisms will help foster public accountability and encourage companies to take proactive steps to reduce their environmental footprint.

6.4 Beyond Transparency

In addition to the existing proposals, more far-reaching measures that go beyond reporting and transparency may need to be considered in the future, particularly as AI's energy demands grow. The following proposals focus on reducing AI's strain on energy resources and fostering more sustainable energy practices:

- **Restrictions on AI Training and Inference During Peak Hours:** One future measure could involve limiting AI training and certain inference tasks (e.g., those for recreation-related purposes) to non-peak energy demand hours [4]. This would reduce the strain on energy grids during peak times and make AI energy usage more manageable and sustainable.
- **Obligations for Data Centers and AI Companies to Create Renewable Energy Sources:** AI companies and data centers should be required to create new renewable energy sources to offset any excess energy demand caused by their operations. This measure could help ensure

that renewable energy, which is a finite resource, is not monopolized by AI and data centers, leaving enough clean energy for the rest of the industry. Clear definitions and guidelines would need to be established to define which types of energy consumption would be covered by this 'new source requirement'.

- **Tradable Energy Budgets for AI:** Another possible long-term measure could involve implementing tradable energy budgets for AI, similar to the EU Emissions Trading System (EU ETS) [4]. Companies that consume particularly large amounts of energy would have a capped energy budget for AI operations and could trade these credits. This would create a market-based approach to managing and reducing AI-related energy consumption. It would, arguably, encourage companies to optimize their energy usage and invest in energy efficiency.

These forward-looking measures go beyond transparency to address the larger-scale challenges AI poses to energy infrastructure and aim to create sustainable solutions that balance AI's growth with the global need for clean energy.

Area	Policy Proposal and Description
Energy and Environmental Reporting	<p>Energy consumption from inferences: Include energy consumption from both single and cumulative inferences in reporting.</p> <p>Indirect emissions and water consumption: Mandate reporting of indirect emissions and water use in AI applications.</p> <p>Cumulative server energy reporting: Require energy consumption to be measured and reported at the cumulative server level.</p>
Legal and Regulatory Clarifications	<p>Clarifying provider status for AI modifications: Limit provider status to substantial AI model modifications.</p> <p>Elimination of open-source exemption: Remove the exemption that allows open-source models to bypass reporting obligations.</p> <p>Renewable energy and efficiency targets for data centers: Introduce binding energy efficiency and renewable energy targets for data centers.</p>
Transparency and Accountability	<p>Public access to climate-related disclosures: Ensure that climate-related disclosures are accessible to the public, not just authorities.</p> <p>Energy reporting for High-Risk AI: Replace computational resource reporting with direct energy consumption disclosures for High-Risk AI systems.</p> <p>Inclusion of environmental risks in assessments: Clarify that environmental risks must be part of risk assessments for AI providers.</p>
Future Far-Reaching Measures	<p>Restrictions during peak energy hours: Limit AI training and non-essential inference tasks to non-peak energy demand periods.</p> <p>Obligation to create renewable energy sources: Require AI companies and data centers to develop renewable energy sources to offset excess energy use.</p> <p>Tradable energy budgets for AI: Introduce a market-based system with tradable energy budgets for AI operations, similar to the EU ETS.</p>

Table 1: Summary of Policy Proposals for AI and Environmental Impact

6.5 Interim Conclusion

By implementing our proposals concerning Energy and Environmental Reporting Obligations, Legal and Regulatory Clarifications, Transparency and Accountability Mechanisms, and Future Far-

Reaching Measures, the AI Act and related regulation can be significantly strengthened to address both immediate and long-term environmental impacts of AI systems. These measures would create a comprehensive framework that not only ensures compliance with current reporting obligations but also anticipates future energy challenges posed by the growing role of AI. The inclusion of market-based approaches and restrictions on AI operations during peak energy periods may help mitigate the broader environmental impact of AI technologies and help navigate the dual, urgent transformations of AI and climate change. Table 1 summarizes our proposals.

7 Conclusion

AI systems, many of them containing energy-intensive generative AI components, are increasingly integrated into economic and societal processes. Importantly, as AI intersects with robotics, writing code and steering devices, it is poised to merge decisively into industrial processes, proliferating its deployment, but also its climate effects. Currently, this intersection between the AI in the green transition sits at a regulatory blind spot, inadequately addressed in current regulation, even in highly regulated jurisdictions, such as the EU.

In this paper, we take closer look at sustainability-related data center regulation in the EU and the US, as well as the sustainability provisions in the AI Act. While they present a good first step, they are too often not ambitious enough or present other shortcomings, like a lack of clarity and consistency, or significant challenges in implementation.

To counter these shortcomings, we make twelve concrete proposals, grouped into four areas: the inclusion of energy consumption during inferences, reporting indirect emissions and water consumption, and energy reporting at the cumulative server level under Energy and Environmental Reporting Obligations; clarification of provider status, elimination of the open-source exemption, and renewable energy targets for data centers under Legal and Regulatory Clarifications; public access to climate disclosures, energy reporting for High-Risk AI, and environmental risks in risk assessments under Transparency and Accountability; and restrictions on AI during peak hours, obligations for renewable energy sources, and tradable energy budgets under Future Far-Reaching Measures beyond Transparency.

References

- [1] Nicolas Alder, Kai Ebert, Ralf Herbrich, and Philipp Hacker. Ai, climate, and transparency: Operationalizing and improving the ai act. *arXiv preprint arXiv:2409.07471*, 2024.
- [2] Anton Beloglazov, Rajkumar Buyya, Young Choon Lee, et al. A Taxonomy and Survey of Energy-Efficient Data Centers and Cloud Computing Systems. *Advances in Computers*, 82: 47–111, 2011.
- [3] Jesse Dodge, Taylor Prewitt, Remi Tachet des Combes, Erika Odmark, Roy Schwartz, Emma Strubell, Alexandra Sasha Luccioni, Noah A Smith, Nicole DeCario, and Will Buchanan. Measuring the carbon intensity of ai in cloud instances. In *Proceedings of the 2022 ACM conference on fairness, accountability, and transparency*, pages 1877–1894, 2022.
- [4] Philipp Hacker. Sustainable ai regulation. *Common Market Law Review*, 61:345–386, 2024.
- [5] Philipp Hacker and Amelie Sophie Berz. Ai and climate: Challenges for regulation. In Cass Sunstein and Lucia Reisch, editors, *Elgar Companion to Consumer Behaviour and the UN Sustainable Development Goals*. Edward Elgar Publishing, 2025. Forthcoming.
- [6] Edward J Hu, yelong shen, Phillip Wallis, Zeyuan Allen-Zhu, Yuanzhi Li, Shean Wang, Lu Wang, and Weizhu Chen. LoRA: Low-rank adaptation of large language models. In *International Conference on Learning Representations*, 2022. URL <https://openreview.net/forum?id=nZeVKeeFYf9>.
- [7] Lynn H Kaack, Priya L Donti, Emma Strubell, George Kamiya, Felix Creutzig, and David Rolnick. Aligning artificial intelligence with climate change mitigation. *Nature Climate Change*, 12(6):518–527, 2022.

- [8] Dhiraj Kalamkar, Dheevatsa Mudigere, Naveen Mellempudi, Dipankar Das, Kunal Banerjee, Sasikanth Avancha, Dharma Teja Vooturi, Nataraj Jammalamadaka, Jianyu Huang, Hector Yuen, et al. A study of bfloat16 for deep learning training. *arXiv preprint arXiv:1905.12322*, 2019.
- [9] Jared Kaplan, Sam McCandlish, Tom Henighan, Tom B Brown, Benjamin Chess, Rewon Child, Scott Gray, Alec Radford, Jeffrey Wu, and Dario Amodei. Scaling laws for neural language models. *arXiv preprint arXiv:2001.08361*, 2020.
- [10] Pengfei Li, Jianyi Yang, Mohammad A Islam, and Shaolei Ren. Making ai less" thirsty": Uncovering and addressing the secret water footprint of ai models. *arXiv preprint arXiv:2304.03271*, 2023.
- [11] Alexandra Sasha Luccioni, Sylvain Viguier, and Anne-Laure Ligozat. Estimating the carbon footprint of bloom, a 176b parameter language model. *Journal of Machine Learning Research*, 24(253):1–15, 2023.
- [12] Sasha Luccioni, Yacine Jernite, and Emma Strubell. Power hungry processing: Watts driving the cost of ai deployment? In *The 2024 ACM Conference on Fairness, Accountability, and Transparency*, pages 85–99, 2024.
- [13] Sasha Luccioni, Bruna Trevelin, and Margaret Mitchell. The environmental impacts of ai – primer. *Hugging Face Blog*, 2024. URL <https://huggingface.co/blog/sasha/ai-environment-primer>. Accessed: 2024-10-08.
- [14] Elisa Morgera and Gracia Marín Durán. Article 37–environmental protection. In Tamara Hervey et al., editors, *The EU Charter of Fundamental Rights*. Hart/Nomos, Baden-Baden, 2 edition, 2022.
- [15] Deepak Narayanan, Mohammad Shoeybi, Jared Casper, Patrick LeGresley, Mostofa Patwary, Vijay Korthikanti, Dmitri Vainbrand, Prethvi Kashinkunti, Julie Bernauer, Bryan Catanzaro, et al. Efficient large-scale language model training on gpu clusters using megatron-lm. In *Proceedings of the International Conference for High Performance Computing, Networking, Storage and Analysis*, pages 1–15, 2021.
- [16] Volnei Pedroni. *Digital Electronics and Design With VHDL*. Morgan Kaufmann, 2008.
- [17] Jack W Rae, Sebastian Borgeaud, Trevor Cai, Katie Millican, Jordan Hoffmann, Francis Song, John Aslanides, Sarah Henderson, Roman Ring, Susannah Young, et al. Scaling language models: Methods, analysis & insights from training gopher. *arXiv preprint arXiv:2112.11446*, 2021.
- [18] Emma Strubell, Ananya Ganesh, and Andrew McCallum. Energy and policy considerations for modern deep learning research. In *Proceedings of the AAAI conference on artificial intelligence*, volume 34, pages 13693–13696, 2020.
- [19] Pablo Villalobos, Anson Ho, Jaime Sevilla, Tamay Besiroglu, Lennart Heim, and Marius Hobbhahn. Position: Will we run out of data? limits of LLM scaling based on human-generated data. In *Forty-first International Conference on Machine Learning*, 2024.
- [20] Zhongwei Wan, Xin Wang, Che Liu, Samiul Alam, Yu Zheng, Jiachen Liu, Zhongnan Qu, Shen Yan, Yi Zhu, Quanlu Zhang, et al. Efficient large language models: A survey. *Transactions on Machine Learning Research*, 2024.
- [21] Carole-Jean Wu, Ramya Raghavendra, Udit Gupta, Bilge Acun, Newsha Ardalani, Kiwan Maeng, Gloria Chang, Fiona Aga, Jinshi Huang, Charles Bai, et al. Sustainable ai: Environmental implications, challenges and opportunities. *Proceedings of Machine Learning and Systems*, 4:795–813, 2022.