

# LAST: LANGUAGE MODEL AWARE SPEECH TOKENIZATION

Arnon Turetzky and Yossi Adi

School of Computer Science and Engineering  
Hebrew University of Jerusalem  
{arnon.turetzky}@mail.huji.ac.il

## ABSTRACT

Speech tokenization serves as the foundation of speech language model (LM), enabling them to perform various tasks such as spoken language modeling, text-to-speech, speech-to-text, etc. Most speech tokenizers are trained independently of the LM training process, relying on separate acoustic models and quantization methods. Following such an approach may create a mismatch between the tokenization process and its usage afterward. In this study, we propose a novel approach to training a speech tokenizer by leveraging objectives from pre-trained *textual* LMs. We advocate for the integration of this objective into the process of learning discrete speech representations. Our aim is to transform features from a pre-trained speech model into a new feature space that enables better clustering for speech LMs. We empirically investigate the impact of various model design choices, including speech vocabulary size and text LM size. Our results demonstrate the proposed tokenization method outperforms the evaluated baselines considering both spoken language modeling and speech-to-text. More importantly, unlike prior work, the proposed method allows the utilization of a single pre-trained LM for processing both speech and text inputs, setting it apart from conventional tokenization approaches.

**Index Terms**— Speech Tokenization, Speech Language Models

## 1. INTRODUCTION

The development of Speech Language Models (SpeechLMs) was recently raised as a new research direction within the spoken language processing community [1, 2, 3, 4, 5, 6, 7, 8]. SpeechLMs are usually composed of two or three main components: (i) speech tokenizer which converts raw speech signals into discrete tokens; (ii) unit Language Model (uLM), operating over this discrete representation to learn the underlying distribution of speech utterances; and (iii) in the generative setup, a unit-based vocoder which converts speech tokens into a waveform signal [1, 9]. The ability to operate directly over raw speech recordings without accessing any textual supervision holds great potential: (i) This can be beneficial for languages that do not have large textual resources or stan-

darized orthography (Swiss German, dialectal Arabic, Igbo, etc.); (ii) It may also be useful for “high-resource” languages, in which the oral and written forms often mismatch; and (iii) It can also model non-verbal cues such as laughter, coughing, etc. Recent studies in the field have shown that following this modeling paradigm can be beneficial for spoken dialogue modeling [10], speaking style conversion and speech emotion conversion [11, 12], direct speech-to-speech translation [13, 14, 15, 16], silent video-to-speech generation [17], etc. In this work, we study the speech tokenization part.

The most common approach nowadays to speech tokenization is applying the k-means algorithm over representations obtained from a pre-trained Self-Supervised Learning (SSL) models, this results in a *semantic speech tokens* [1, 5]. While being simple and effective, this approach has several drawbacks. First, it requires a separate training stage on top of the SSL model, and can not be done jointly. Second, it is not clear what layer should we use to obtain representations to train the k-means model. Prior work proposed different layers [1, 4, 18] and show varying results when different layers are being chosen, even when considering the same model. Lastly, the k-means model is sensitive to the data used to learn the cluster centroids. Hence, it remains an open question of what data should be used to train the clustering model. Prior work found that different dataset splits result in different model performance [18]. Another line of speech and audio tokenization was proposed by [19, 20] using a Residual Vector Quantization (RVQ) method under the auto-encoding setup. Such a tokenization method is highly general and can capture any type of audio (not only speech), however, it was found to be challenging to optimize SpeechLMs on top of it without conditioning on text or semantic tokens [5]. Such representation is often denoted as *acoustic tokens*.

Considering the fact that the above-mentioned tokens will be later on used to train SpeechLMs, raises the following question: *can we construct a speech tokenizer which will be guided by a language model?* Moreover, recently [21] found that performing a warm-initialization of SpeechLMs parameters from a pre-trained text LM, such as OPT [22] or LLaMA 2 [23], results in superior performance to cold-random initialization.

Equipped with the above findings we propose LAST,

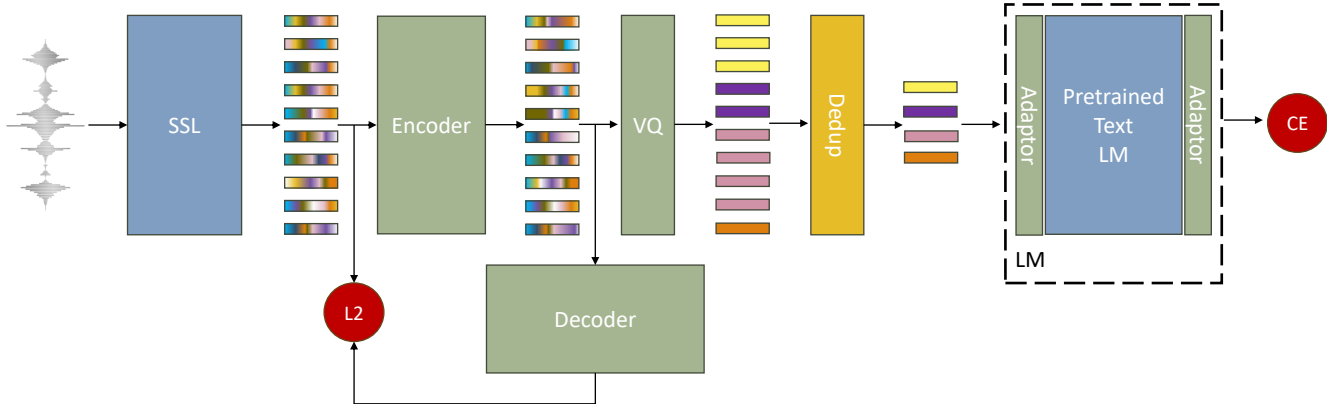

**Fig. 1: A visual description of LAST.** We propose to leverage a pre-trained text-LM to construct a speech tokenizer. LAST receives gradients from the LM to guide the tokenization process toward better sequence modeling. Pretrained frozen modules are blue and learned modules are green.

which stands for Language Model Aware Speech Tokenization. Specifically, we propose to involve a pre-trained text LM during the tokenization process to result in speech tokens that will be better suited for sequential modeling. Generally, LAST is comprised of three main components: (i) a pre-trained, frozen speech SSL model which extracts contextualized speech representations from speech signals. We experimented with HuBERT [24], however LAST is general and can be applied to any SSL method; (ii) an adapter-quantization module which converts this contextualized representation into discrete tokens; and (iii) a pre-trained, frozen LM which guides the tokenization process towards better sequential modeling. A visual description of the proposed method can be seen on Figure 1. Notice, in contrast to [21] which fine-tunes text LM using speech tokens, and as a result removing the learned textual information, the proposed approach keeps the text-LM frozen, hence does not affect performance on text benchmarks.

We evaluate LAST on a set of zero-resource speech modeling tasks [25] and found the proposed method is superior to the traditional k-means method across all setups. We also evaluate the ability of the newly proposed speech tokens on the task of Automatic Speech Recognition (ASR) and found them to produce superior performance than the k-means alternative. We additionally provide an extensive ablation study, which sheds light on the importance of each of the components constructing LAST.

## 2. BACKGROUND

As mentioned before, the general pipeline for constructing SpeechLMs is comprised of two main modules: (i) Speech tokenizer and (ii) uLM (See Figure 2 for a visual description). In the following paragraphs, we give a background for each of the components including the standard evaluation methods.

**Speech Tokenizer** module encodes the raw speech signal into a discrete representation. The common approach is first to encode the speech into a continuous representation and then quantize the representation to achieve a sequence of discrete units [1, 9, 15, 13, 4, 11, 2, 10, 5, 26, 27].

Formally, denote the domain of audio samples by  $\mathcal{X} \subset \mathbb{R}$ . The representation for a raw signal is therefore a sequence of samples  $x = (x_1, \dots, x_T)$ , where  $x_t \in \mathcal{X}$  for all  $1 \leq t \leq T$ .

Consider an encoder network,  $f$ , that gets as input the speech utterance and outputs a sequence of spectral representations sampled at a low frequency as follows  $f(x) = (v_1, \dots, v_{T'})$ . Note that we do not assume anything about the structure of the encoder network  $f$ . [1], evaluated several speech encoders, namely, Mel-spectrogram, Contrastive Predictive Coding [28], wav2vec2 [29], and HuBERT [24].

Since the representations learned by such models are usually continuous, a tokenization or quantization algorithm is applied over the models' outputs to generate discrete units, denoted as  $z = (z_1, \dots, z_{T'})$ . Each element  $z_i$  in  $z$  is a positive integer,  $z_i \in \{1, \dots, K\}$  for  $1 \leq i \leq T'$ , where  $K$  is the number of discrete units. We denote the quantization model with  $Q$ . The common approach in prior work is to use the k-means algorithm as the quantization method.

**Unit Language Model** is trained on the extracted discrete units,  $z$ . Such a language model learns a probability distribution of the learned unit sequences, which enables direct modeling of speech data without textual supervision.

The language model can be used to sequentially model speech utterances, and generate speech conditionally or unconditionally. Moreover, such a modeling framework allows for capturing and modeling prosodic features [4], as well as speaker identity [5], or even natural dialogues [10]. This is in contrast to using textual features, as they do not encode such information. In this work, we do not focus on speech generation but rather demonstrate that the proposed speech tokenizer

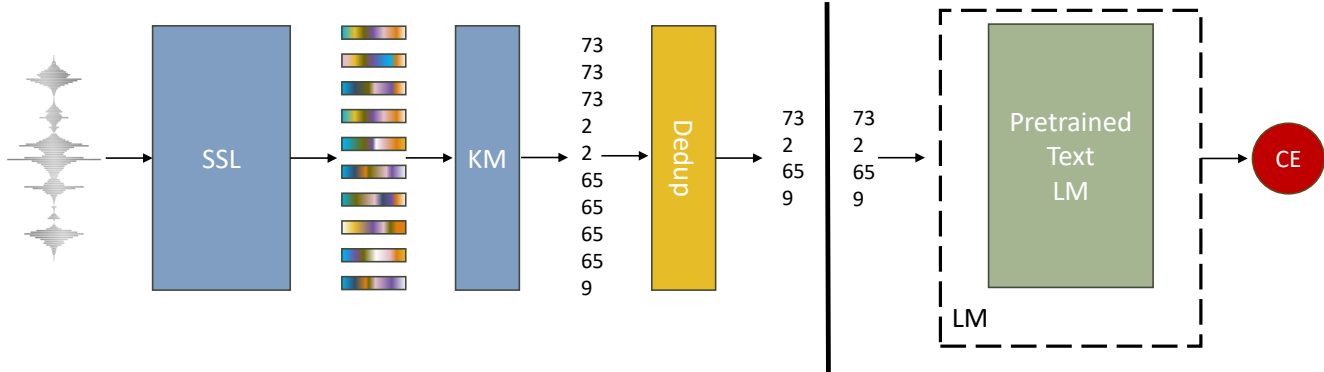

**Fig. 2: The common *SpeechLM* pipeline.** First, discrete representation is extracted from the raw waveform using both a speech encoder and a quantization module (often known as a speech tokenizer). This representation is later used for training a uLM. In this study, we focus on the speech tokenization part.

provides better performance for modeling sequential data via the uLM.

**Zero-Resource Speech Evaluation.** [25] proposed a set of zero-shot evaluation tasks specifically targeting speech modeling (i.e., sWUGGY, and sBLIMP). The sWUGGY metric requires detecting the real word from a pair of short utterances such as 'brick' vs. 'blick.' Similarly, sBLIMP requires detecting the syntactically correct sentence from a pair of sentences. In both metrics, detection is done by comparing the probabilities of both sequences. These metrics are desirable under our setup as, unlike perplexity, these allow us to compare models with different tokenizers. We mainly report this method throughout the paper.

### 3. LANGUAGE AWARE SPEECH TOKENIZER

In this section we present LAST. We start by describing the speech tokenization approach guided by a frozen LM, followed by the exact implementation details and fine tuning configuration.

#### 3.1. Model

Given a speech utterance  $x$ , we first feed it into a frozen and pre-trained speech encoder network  $f(x) = v = (v_1, \dots, v_{T'})$ , where each  $v_i \in \mathbb{R}^d$ . Next,  $v$  is being fed into a learnable encoder module  $E(v) = u = (u_1, \dots, u_{T'})$ , where each  $u_i \in \mathbb{R}^{d'}$ . Then, a quantization process is performed, via a Vector Quantization (VQ) module,  $Q$ , to quantize each  $u_i$ . Formally,  $Q(u) = (z_1, \dots, z_{T'})$ , where each  $z_i$  is a positive integer in the range of  $\{1, \dots, K\}$  and  $K$  is the number of codes in  $Q$ .

Next, to guide the quantization process toward sequential modeling, we feed  $z$  into a pre-trained textual LM to perform next token prediction. To extend the text LM for speech tokens, we add randomly initialized adaptation layers before

and after the LM which we freeze for the entire training, hence keeping the existing text LM capabilities unchanged. We analyze the effect of the adapter size in Section 6.3.

Similarly to the common practice in training LMs we minimize the negative log-likelihood loss between the predicted and true probability distributions over the learned tokens. Formally, we minimize the following,

$$\mathcal{L}_{LM} = - \sum_{i=1}^n \log p_{\theta}(z_i | z_{i-1}, \dots, z_1), \quad (1)$$

where we consider  $\theta$  as the parameters of both the adaptor and new speech tokens look-up table. We do not update the LM parameters, we only backpropagate through it.

Notice, that we learn to tokenize speech via next token prediction. Such an optimization process may easily collapse to a single token or a sequence of tokens. To prevent collapse we introduce a reconstruction loss function to stabilize the optimization process. For that, we introduce a decoder module,  $D$ , which gets as input  $u$  and is optimized to reconstruct  $v$ . Specifically, we minimize the L2 loss between  $D(u)$  and  $v$ . Overall, the objective function of the system is as follows,

$$\mathcal{L} = \mathcal{L}_{LM} + \lambda \|D(u) - v\|_2, \quad (2)$$

where  $\lambda$  is a hyperparameter balancing between both loss functions. A visual description of the proposed method can be seen in Figure 1.

#### 3.2. Details

We set  $f$  to be a pre-trained HuBERT-base can be beneficial for languages that do not have large textual resources or even a widely used standardized orthographybase model [24]. Similarly to [21], representations are obtained from its 9th layer. For  $E$ , we utilize a transformer encoder followed by a projection layer, where the latent dimension  $d'$  is determined by the LM dimension.

Model	TWIST	sWUGGY <sup>↑</sup>		sBLIMP <sup>↑</sup>
		Inter	OOV	
k-means	×	63.53	54.06	53.3
k-means	✓	72.61	57.47	55.73
LAST	×	70.79	57.13	54.76
LAST <sup>†</sup>	×	71.78	57.19	55.25
LAST	✓	74.24	58.37	56.80

**Table 1:** Zero-resource speech metrics for sequence modeling. We present results for both k-means tokenizer and LAST with and without finetuning the LM. Results are presented using an OPT model with 350M parameters and a codebook size of 500. TWIST refers to fine-tuning the SpeechLM initialized from text LM parameters. LAST with adaptation layers marked with †

We employ VQ [30, 19] to discretize the output  $u$  where we experimented number of codebooks  $\in \{100, 200, 500, 1000\}$ . We empirically analyze results for the different number of codebooks in Section 6.1.

For the LM part, we utilize the OPT model [22] with 125M and 350M parameter models. These models are initialized from a pre-trained text LM following [21]. We employ a separate lookup table with with a new randomly initialized embedding and add two more projection layers to enable speech tokens in addition to text tokens. In order to feed tokens into the model as input, the first layer projects from the embedding dimension to the model dimension. The second layer maps the model output to the number of tokens, allowing for the calculation of next speech token probabilities. In our setup we use only the speech tokens but using both text and speech tokens, only requires an indicator to specify whether to use text or speech. This indicator will determine which group of layers should be used for each token. Similarly to [31] we remove sequential repetitions of speech tokens before feeding them into the LM. Notice, unlike [21] which fine-tunes the text LM and as a result removes text modeling capabilities, following the proposed approach keeps the original performance over text benchmarks unchanged while extending it to speech modeling ones. We update the LM lookup table with the vector quantization codebooks at each training step and feed  $z$  as input for the LM.

**Finetune.** Although the proposed method allows the utilization of a single pre-trained LM for processing both speech and text inputs, we would also evaluate LAST similarly to [21], i.e., finetuning the LM. We denote the difference between both cases as “Pretrain” and “Finetune” to avoid confusion.

## 4. EXPERIMENTAL SETUP

We use different numbers and types of GPUs across our experiments due to diverse computational requirements ranging from single to 4 GPUS out of the Nvidia A5000, A6000, and A40. Due to computational constraints we use grad accumulation, and set a limit for maximum steps. Unless stated otherwise, except for the speech recognition experiments, we set a limit of  $200K$  optimization steps with a batch size of 32. We sampled 10 seconds from each example and zero padded from right whenever needed. We used AdamW optimizer and linear-warmup-cosine scheduler that increase learning rate from 0 to  $1e - 4/2.5e - 5$  by  $1K/10K$  steps then decrease to  $3e - 5/1e - 5$  for pretraining and finetuning experiments respectively. Speech recognition experiments were limited to  $150K$  steps with batch size 64, same optimizer and scheduler but with a warmup of  $5K$  steps to learning rate  $1e - 4$  decrease to  $1e - 5$ .

## 5. RESULTS

We report results for the zero-resource speech metrics [32, 25] together with speech recognition metrics, comparing the proposed method to the k-means alternative.

### 5.1. Zero-Resource Speech Metrics

We start by evaluating the proposed method using the zero-resource speech metrics as proposed by [25], namely sWUGGY and sBLIM, and compare it to the commonly used k-means tokenizer. Unless stated otherwise, for a fair comparison we follow the same approach as in [31] and report the results for the “in-vocabulary” split. For both measures, we compare the geometric mean of the models’ sequence probabilities assigned to each utterance within a pair. We report results in two setups. In the first one, we keep the LM frozen and do not update its parameters. In the second setup, we follow TWIST [21], and we fine-tune the LM initialized from a text model. For a fair comparison to the k-means baseline, we consider two setups of LAST: with and without the adaptation layers. Both LAST and the k-means baseline are built on top of the HuBERT-base model. Results are presented in Table 1 using with OPT-350 model and codebook size of 500.

We observe a consistent improvement across all the evaluated setups when following the proposed approach compared to the evaluated baseline. When considering no TWIST fine-tuning of the LM, LAST significantly outperforms the k-means alternative. Interestingly, even without applying TWIST to the proposed method it provides competitive performance to TWIST using the k-means tokenizer.

Another benefit of following LAST is it requires significantly fewer tunable parameters compared to TWIST. For example, to obtain the results presented in Table 1 LAST requires training  $\sim 230M$  parameters less than TWIST.

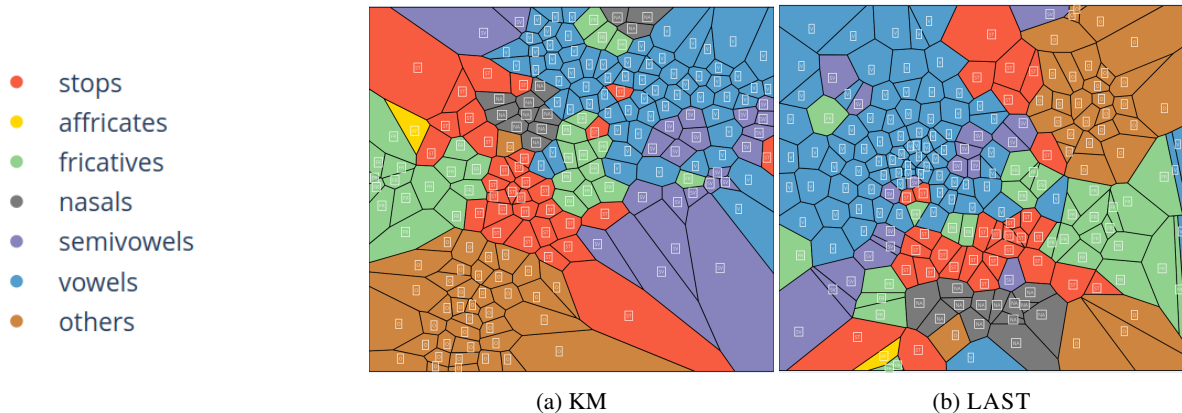

**Fig. 3:** Units visualization. Each bounded area represents a single unit out of 200 and is colored by the unit’s phoneme family.

Model	WER↓				ABX↓	
	test clean	test other	dev clean	dev other	acr.	wit.
k-means	6.83	15.57	6.59	15.25	5.88	4.54
LAST	6.08	13.67	5.67	13.51	7.73	6.28

**Table 2:** LibriSpeech WER (%) of different tokenization methods. Subsets clean and other referred as ”c” and ”o”

## 5.2. Speech Recognition

Next, we evaluate how the proposed tokenization method is able to preserve linguistic content. For that, we train an acoustic model for the task of ASR and measured the Word-Error-Rate (WER). We train a T5-base [33] seq2seq model on LS-960. Text tokenization is similar across all methods using T5-base pre-trained tokenizer.

We additionally measure the ABX metric, as proposed by [32]. Unlike WER which measures the content preservation at the word level, ABX operates at the phoneme level. The ABX task measures the phonetic discriminative abilities of the representation. It involves a pair of words differing by a single phoneme and a reference test word sharing a phoneme with one of the pair. It assesses whether the test phoneme is closer in representation to the correct or incorrect phoneme, expecting a shorter distance to the correct one. The ABX task is conducted in two setups: ’within’ and ’across’. ’Within’ is evaluated on input data from the same speaker, while ’across’ is evaluated on input data from different speakers. Notice, our goal is not to construct the best performing ASR model [34, 35], we are primarily interested in comparing the relative results of LAST compared to the k-means alternative.

Results are presented in Table 2. When considering the WER metric, LAST shows superior performance than the k-means alternative, however, when considering the ABX metric, the k-means method outperforms LAST. Considering the

way both methods were constructed, these findings imply that the k-means model better captures phonemic information.

To better analyze this, we follow [36] and visualize the tokens clusters as a function of phoneme families measured over the TIMIT corpus which contains full alignment. For each token cluster, we select the majority phoneme, the one that was most present in the cluster. Results are depicted in Figure 3. Results suggest that both methods are correlative with phonetic information.

## 6. ABLATION

We turn into analyzing the different components composing LAST. We start by evaluating the effect of the vocabulary size, we systematically compare different numbers of codebook sizes. Next, we evaluate the effect of the LM tokenizer used and the final SpeechLM. We consider LM of different sizes from the OPT family of models. Lastly, we consider different numbers of layers for encoding, decoding and modality adapting layers.

### 6.1. Vocabulary Size

Similarly to [37, 31, 21] we experiment with different codebook sizes to better evaluate the effect of the number of tokens on modelling performance. We measure zero-resource speech metrics (i.e., sWUGGY and sBLIMP) using SpeechLMs with the additional decoding layers. Results are reported in Table 3. Results suggest that 500 tokens provide the best performance. Interestingly using 1000 units provides inferior performance to even 100 units. We suspect this is due to high redundancy in the codebook usage.

### 6.2. Tokenizer-Model Relation

Next, we evaluate the effect of LM size on the tokenization method and as a SpeechLM afterwards. We consider different model sizes from the OPT model family (i.e., 125M

# Tokens	sWUGGY	sBLIMP
100	68.55	54.82
200	70.66	54.08
500	<b>71.78</b>	<b>55.25</b>
1000	67.77	54.64

**Table 3:** LAST zero-shot modeling results for different numbers of tokens.

Model LM	Tokenizer LM	sWUGGY	sBLIMP
OPT-125M	OPT-125M	70.81	55.13
	OPT-350M	<b>72.66</b>	<b>55.27</b>
OPT-350M	OPT-350M	<b>74.24</b>	<b>56.80</b>

**Table 4:** We evaluate the effect of the LM size used training LAST on the zero-shot modeling results finetuning pre-trained text LM.

and 350M parameters) as either the SpeechLM and the model used for tokenization (denoted by Tokenizer LM). Results are reported in Table 4.

We observe several interesting findings: (i) although conducting the experiments on the same model family, we can say our tokenizers can be used by different LMs. (ii) finetuning the 125M with the tokenizer trained with the 350M LM achieves better results than the one finetuned with the tokenizer train with the 125M LM.

### 6.3. Modelling Choices

**Model Architecture.** We analyze the effect of different architectural choices of LAST. Specifically, we consider different numbers of layers in the encoder, decoder, and adaptation modules. For the adaptation module, we additionally consider a varying number of layers before and after the LM. In all setups, we report the sWUGGY metric using OPT-350 with 500 tokens. Results presented in Table 5.

Results suggest that except of one setup (second row in Table 5), the proposed method is not sensitive to the specific design choice. However, a few interesting insights comes up: (i) using 2 layers for all modules provides the best overall results; (ii) using more adaptation layers before the LM provides superior performance than using more adaptation layers after the LM; and (iii) using equal number of adaptation layers before and after the LM provides the best performance and stabilizes the results, as long as there is enough capacity in the encoder module.

**Reconstruction loss.** Lastly, we discussed the need for the L2 loss Section 3.2 to prevent collapse during model optimization. Specifically, we proposed to regularize the training

process with an L2 loss between the  $D(u)$  and  $v$ . To evaluate different regularization alternatives, we experiment with replacing  $v$  with the different layer from  $f$  (HuBERT model), specifically layer 10 or with the acoustic features obtained from the first CNN layers in HuBERT. However, we found both options to provide inferior performance to the currently used one.

## 7. RELATED WORK

**Speech Language Models.** Speech language models were first demonstrated by [1]. The authors showed how raw and uncurated speech data can be leveraged into building a Generative Spoken Language Modeling (GSLM) system. Next, [4] proposed a multi-stream SpeechLM to jointly process “pseudo-text” tokens together with quantized prosodic features (i.e., duration and F0). Such a modeling framework opened up a new and promising research direction for processing and modeling spoken data. [9] evaluated the robustness and disentanglement properties of speech-to-tokens models and demonstrated the ability to perform voice conversion as well as a lightweight speech codec. [11] proposed to cast the task of speech emotion conversion as a translation task, hence translating between one emotion to the other in the discrete space, while [12] proposed a similar approach for speaking style conversion. [10] proposed training two SpeechLMs jointly to mimic natural spoken dialogues. Recently, [5] proposed cascading several LMs, in which one LM operates over semantic speech tokens while the others operate on acoustic tokens. Such modeling framework allows generating natural speech while keeping the identity of the speaker and acoustic conditions unchanged [38, 39]. [36] show that the semantic units obtained from such models highly correlate to phonemes and phoneme states. [13, 14, 15, 16] followed a similar modeling mechanism using a different speech tokenizer and proposed a textless approach for speech-to-speech translation. [40, 41] and [42] considered speech as another language in multilingual setups, and showed that involving speech and text as part of training data improves results for speech translation and multilingual text tasks. [43, 44] and [45] used the joint training to improve transcriptions tasks as ASR and Text-to-Speech (TTS). [46] proposed augmenting a text LM with continuous speech data to improve spoken question-answering tasks.

**Speech and Audio Tokenizers.** The most common approach to tokenize speech for spoken language modeling is the k-means method, which was first proposed by [1]. Later on, other studies follow a similar modeling paradigm [5, 11, 4, 8]. These results in a discrete semantic representation of the speech signal. [47, 48] pointed out the lack of robustness in current k-means tokenization methods and proposed to match representations from clean and augmented signals. Another

# Enc	# Dec	# LM-AB	# LM-AA	sWUGGY
2	2	1	1	68.78
2	2	1	3	59.21
2	2	3	1	69.47
2	2	2	2	<b>71.78</b>
3	1	2	2	70.31
1	3	2	2	67.78
1	1	2	2	70.39

**Table 5:** Model architecture ablation. We compare LAST variations with different numbers of trainable layers across different modules. # Enc and # Dec stands for the number of encoder and decoder layers in the adaptors respectively. # LM-AB and # LM-AA stands for the number of layers in the adaptation layers before and after the the LM respectively.

alternative approach is to follow the VQ-VAE approach using an RVQ [19, 20]. Due to its objective function, such representation better captures acoustic information rather than semantic information. Recent studies either use the semantic tokens [1, 21], the acoustic tokens conditioned on global textual descriptions [49, 50, 38], or both semantic and acoustic tokens [5]. Recently, [51] proposed to jointly train speech tokenizers to capture both semantic and acoustic tokens. The authors proposed training a discrete auto-encoder using RVQ and optimizing the first RVQ codebook to be similar to the semantic tokens obtained from the k-means model. Notice, that all of the above methods are orthogonal to the proposed method as they can be applied jointly with our method.

Another relevant related work to ours is the work by [52, 53] that proposes to leverage a pre-train text-to-image and text-to-video models (respectively) to build image and video generation models condition on audio inputs. The authors proposed to augment the textual inputs with the newly learned single audio token. Unlike these works, our method is focused on speech and not general audio, and more importantly, aimed at learning a full vocabulary over time rather than a single audio token.

## 8. DISCUSSION

In this study, we propose LAST: a language model aware speech tokenization method. Unlike prior work, which constructs the speech tokens independently from the SpeechLM, LAST involves the SpeechLM during the tokenization process. LAST leverages both frozen pre-trained contextualized speech encoder and frozen pre-trained text LM while introducing a lightweight modality adapter. Results suggest LAST provides superior performance to the k-means alternative considering both zero-resource metrics and transcription capabilities. Interestingly, as LAST augments a frozen pre-trained text LM, it is not only superior in terms of speech

modeling but also keeps the same text capabilities of the original LM model.

**Limitations.** While LAST is superior to the k-means alternative and allows to optimize jointly the speech tokenizer and SpeechLMs, it requires more computational resources than the standard k-means approach. Additionally, we only presented results for zero-resource speech modeling metrics, more evaluations are needed in the direction of unit-to-speech synthesis. We leave that for future research.

**Future work.** We intend to extend this work in two main directions: (i) as mentioned above, evaluating LAST also under the unit-to-speech synthesis framework. This will allow us to evaluate the system similarly to the GSLM setup as was done by [1]. Additionally, as the demonstrated that a frozen text LM can be efficiently augmented with speech tokens, we intend to explore the merger of the two modalities in the form of ASR and TTS.

**Acknowledgements.** This research work was supported by ISF grant 2049/22.

## 9. REFERENCES

- [1] Kushal Lakhota, Eugene Kharitonov, Wei-Ning Hsu, Yossi Adi, Adam Polyak, Benjamin Bolte, Tu-Anh Nguyen, Jade Copet, Alexei Baevski, Abdelrahman Mohamed, and Emmanuel Dupoux, “On Generative Spoken Language Modeling from Raw Audio,” *TACL*, 2021.
- [2] Eugene Kharitonov, Jade Copet, Kushal Lakhota, Tu Anh Nguyen, Paden Tomasello, Ann Lee, Ali Elkahky, Wei-Ning Hsu, Abdelrahman Mohamed, Emmanuel Dupoux, et al., “textless-lib: a library for textless spoken language processing,” *arXiv preprint arXiv:2202.07359*, 2022.
- [3] Joonyong Park, Shinnosuke Takamichi, Tomohiko Nakamura, Kentaro Seki, Detai Xin, and Hiroshi Saruwatari, “How generative spoken language modeling encodes noisy speech: Investigation from phonetics to syntactics,” *arXiv preprint arXiv:2306.00697*, 2023.
- [4] Eugene Kharitonov, Ann Lee, Adam Polyak, Yossi Adi, Jade Copet, Kushal Lakhota, Tu-Anh Nguyen, Morgane Rivière, Abdelrahman Mohamed, Emmanuel Dupoux, et al., “Text-free prosody-aware generative spoken language modeling,” *arXiv preprint arXiv:2109.03264*, 2021.
- [5] Zalán Borsos, Raphaël Marinier, Damien Vincent, Eugene Kharitonov, Olivier Pietquin, Matt Sharifi, Olivier Teboul, David Grangier, Marco Tagliasacchi, and Neil Zeghidour, “Audiolm: a language modeling approach

- to audio generation,” *arXiv preprint arXiv:2209.03143*, 2022.
- [6] Kaizhi Qian, Yang Zhang, Heting Gao, Junrui Ni, Cheng-I Lai, David Cox, Mark Hasegawa-Johnson, and Shiyu Chang, “Contentvec: An improved self-supervised speech representation by disentangling speakers,” in *ICML*, 2022.
- [7] Robin Algayres, Yossi Adi, Tu Anh Nguyen, Jade Copet, Gabriel Synnaeve, Benoit Sagot, and Emmanuel Dupoux, “Generative spoken language model based on continuous word-sized audio tokens,” *arXiv preprint arXiv:2310.05224*, 2023.
- [8] Guan-Wei Wu, Guan-Ting Lin, Shang-Wen Li, and Hung-yi Lee, “Improving textless spoken language understanding with discrete units as intermediate target,” *arXiv preprint arXiv:2305.18096*, 2023.
- [9] Adam Polyak, Yossi Adi, Jade Copet, Eugene Kharitonov, Kushal Lakhota, Wei-Ning Hsu, Abdelrahman Mohamed, and Emmanuel Dupoux, “Speech resynthesis from discrete disentangled self-supervised representations,” *arXiv preprint arXiv:2104.00355*, 2021.
- [10] Tu Anh Nguyen, Eugene Kharitonov, Jade Copet, Yossi Adi, Wei-Ning Hsu, Ali Elkahky, Paden Tomasello, Robin Algayres, Benoit Sagot, Abdelrahman Mohamed, et al., “Generative spoken dialogue language modeling,” *arXiv preprint arXiv:2203.16502*, 2022.
- [11] Felix Kreuk, Adam Polyak, Jade Copet, Eugene Kharitonov, Tu-Anh Nguyen, Morgane Rivière, Wei-Ning Hsu, Abdelrahman Mohamed, Emmanuel Dupoux, and Yossi Adi, “Textless speech emotion conversion using decomposed and discrete representations,” *arXiv preprint arXiv:2111.07402*, 2021.
- [12] Gallil Maimon and Yossi Adi, “Speaking style conversion with discrete self-supervised units,” *arXiv preprint arXiv:2212.09730*, 2022.
- [13] Ann Lee, Peng-Jen Chen, Changhan Wang, Jiatao Gu, Xutai Ma, Adam Polyak, Yossi Adi, Qing He, Yun Tang, Juan Pino, et al., “Direct speech-to-speech translation with discrete units,” *arXiv preprint arXiv:2107.05604*, 2021.
- [14] Ann Lee, Hongyu Gong, Paul-Ambroise Duquenne, Holger Schwenk, Peng-Jen Chen, Changhan Wang, Sravya Popuri, Yossi Adi, Juan Pino, Jiatao Gu, and Wei-Ning Hsu, “Textless speech-to-speech translation on real data,” in *NAACL*, 2022.
- [15] Sravya Popuri, Peng-Jen Chen, Changhan Wang, Juan Pino, Yossi Adi, Jiatao Gu, Wei-Ning Hsu, and Ann Lee, “Enhanced direct speech-to-speech translation using self-supervised pre-training and data augmentation,” *arXiv preprint arXiv:2204.02967*, 2022.
- [16] Yifan Peng, Ilia Kulikov, Yilin Yang, Sravya Popuri, Hui Lu, Changhan Wang, and Hongyu Gong, “Mslm-s2st: A multitask speech language model for textless speech-to-speech translation with speaker style preservation,” *arXiv preprint arXiv:2403.12408*, 2024.
- [17] Wei-Ning Hsu, Tal Remez, Bowen Shi, Jacob Donley, and Yossi Adi, “Revise: Self-supervised speech resynthesis with visual input for universal and generalized speech enhancement,” *arXiv preprint arXiv:2212.11377*, 2022.
- [18] Tu Anh Nguyen, Wei-Ning Hsu, Antony d’Avirro, Bowen Shi, Itai Gat, Maryam Fazel-Zarani, Tal Remez, Jade Copet, Gabriel Synnaeve, Michael Hassid, et al., “Espresso: A benchmark and analysis of discrete expressive speech resynthesis,” *arXiv preprint arXiv:2308.05725*, 2023.
- [19] Alexandre Défossez, Jade Copet, Gabriel Synnaeve, and Yossi Adi, “High fidelity neural audio compression,” *arXiv preprint arXiv:2210.13438*, 2022.
- [20] Neil Zeghidour, Alejandro Luebs, Ahmed Omran, Jan Skoglund, and Marco Tagliasacchi, “Soundstream: An end-to-end neural audio codec,” *IEEE/ACM Transactions on Audio, Speech, and Language Processing*, vol. 30, pp. 495–507, 2021.
- [21] Michael Hassid, Tal Remez, Tu Anh Nguyen, Itai Gat, Alexis Conneau, Felix Kreuk, Jade Copet, Alexandre Defossez, Gabriel Synnaeve, Emmanuel Dupoux, et al., “Textually pretrained speech language models,” *Advances in Neural Information Processing Systems*, vol. 36, 2024.
- [22] Susan Zhang, Stephen Roller, Naman Goyal, Mikel Artetxe, Moya Chen, Shuohui Chen, Christopher Dewan, Mona Diab, Xian Li, Xi Victoria Lin, et al., “Opt: Open pre-trained transformer language models,” *arXiv preprint arXiv:2205.01068*, 2022.
- [23] Hugo Touvron, Louis Martin, Kevin Stone, Peter Albert, Amjad Almahairi, Yasmine Babaei, Nikolay Bashlykov, Soumya Batra, Prajjwal Bhargava, Shruti Bhosale, et al., “Llama 2: Open foundation and fine-tuned chat models,” *arXiv preprint arXiv:2307.09288*, 2023.
- [24] Wei-Ning Hsu, Benjamin Bolte, Yao-Hung Hubert Tsai, Kushal Lakhota, Ruslan Salakhutdinov, and Abdelrahman Mohamed, “Hubert: Self-supervised speech representation learning by masked prediction of hidden units,” *IEEE/ACM Transactions on Audio, Speech, and Language Processing*, 2021.



- [25] Tu Anh Nguyen, Maureen de Seyssel, Patricia Rozé, Morgane Rivière, Evgeny Kharitonov, Alexei Baevski, Ewan Dunbar, and Emmanuel Dupoux, “The zero resource speech benchmark 2021: Metrics and baselines for unsupervised spoken language modeling,” in *NeurIPS – Self-Supervised Learning for Speech and Audio Processing Workshop*, 2020.
- [26] Andros Tjandra, Berrak Sisman, Mingyang Zhang, Sakriani Sakti, Haizhou Li, and Satoshi Nakamura, “Vqvae unsupervised unit discovery and multi-scale code2spec inverter for zerospeech challenge 2019,” in *Interspeech*, 2019.
- [27] Andros Tjandra, Sakriani Sakti, and Satoshi Nakamura, “Transformer vq-vae for unsupervised unit discovery and speech synthesis: Zerospeech 2020 challenge,” in *Interspeech*, 2020.
- [28] Aaron van den Oord, Yazhe Li, and Oriol Vinyals, “Representation learning with contrastive predictive coding,” *arXiv preprint arXiv:1807.03748*, 2018.
- [29] Alexei Baevski, Yuhao Zhou, Abdelrahman Mohamed, and Michael Auli, “wav2vec 2.0: A framework for self-supervised learning of speech representations,” *NeurIPS*, 2020.
- [30] Aaron Van Den Oord, Oriol Vinyals, et al., “Neural discrete representation learning,” *Advances in neural information processing systems*, vol. 30, 2017.
- [31] Kushal Lakhota, Eugene Kharitonov, Wei-Ning Hsu, Yossi Adi, Adam Polyak, Benjamin Bolte, Tu-Anh Nguyen, Jade Copet, Alexei Baevski, Abdelrahman Mohamed, et al., “On generative spoken language modeling from raw audio,” *Transactions of the Association for Computational Linguistics*, vol. 9, pp. 1336–1354, 2021.
- [32] Ewan Dunbar, Xuan Nga Cao, Juan Benjumea, Julien Karadayi, Mathieu Bernard, Laurent Besacier, Xavier Anguera, and Emmanuel Dupoux, “The zero resource speech challenge 2017,” in *2017 IEEE Automatic Speech Recognition and Understanding Workshop (ASRU)*. IEEE, 2017, pp. 323–330.
- [33] Colin Raffel, Noam Shazeer, Adam Roberts, Katherine Lee, Sharan Narang, Michael Matena, Yanqi Zhou, Wei Li, and Peter J. Liu, “Exploring the limits of transfer learning with a unified text-to-text transformer,” *Journal of Machine Learning Research*, vol. 21, no. 140, pp. 1–67, 2020.
- [34] Xuankai Chang, Brian Yan, Yuya Fujita, Takashi Maekaku, and Shinji Watanabe, “Exploration of efficient end-to-end asr using discretized input from self-supervised learning,” *arXiv preprint arXiv:2305.18108*, 2023.
- [35] Xuankai Chang, Brian Yan, Kwanghee Choi, Jeeweon Jung, Yichen Lu, Soumi Maiti, Roshan Sharma, Jiatong Shi, Jinchuan Tian, Shinji Watanabe, et al., “Exploring speech recognition, translation, and understanding with discrete speech units: A comparative study,” *arXiv preprint arXiv:2309.15800*, 2023.
- [36] Amitay Sicherman and Yossi Adi, “Analysing discrete self supervised speech representation for spoken language modeling,” *arXiv preprint arXiv:2301.00591*, 2023.
- [37] Wei-Ning Hsu, Benjamin Bolte, Yao-Hung Hubert Tsai, Kushal Lakhota, Ruslan Salakhutdinov, and Abdelrahman Mohamed, “Hubert: Self-supervised speech representation learning by masked prediction of hidden units,” *IEEE/ACM Transactions on Audio, Speech, and Language Processing*, vol. 29, pp. 3451–3460, 2021.
- [38] Chengyi Wang, Sanyuan Chen, Yu Wu, Ziqiang Zhang, Long Zhou, Shujie Liu, Zhuo Chen, Yanqing Liu, Huaming Wang, Jinyu Li, et al., “Neural codec language models are zero-shot text to speech synthesizers,” *arXiv preprint arXiv:2301.02111*, 2023.
- [39] Eugene Kharitonov, Damien Vincent, Zalán Borsos, Raphaël Marinier, Sertan Girgin, Olivier Pietquin, Matt Sharifi, Marco Tagliasacchi, and Neil Zeghidour, “Speak, read and prompt: High-fidelity text-to-speech with minimal supervision,” *Transactions of the Association for Computational Linguistics*, vol. 11, pp. 1703–1718, 2023.
- [40] Ankur Bapna, Yu-an Chung, Nan Wu, Anmol Gulati, Ye Jia, Jonathan H Clark, Melvin Johnson, Jason Riesa, Alexis Conneau, and Yu Zhang, “Slam: A unified encoder for speech and language modeling via speech-text joint pre-training,” *arXiv preprint arXiv:2110.10329*, 2021.
- [41] Yong Cheng, Yu Zhang, Melvin Johnson, Wolfgang Macherey, and Ankur Bapna, “Mu<sup>2</sup> slam: Multi-task, multilingual speech and language models,” *arXiv preprint arXiv:2212.09553*, 2022.
- [42] Ankur Bapna, Colin Cherry, Yu Zhang, Ye Jia, Melvin Johnson, Yong Cheng, Simran Khanuja, Jason Riesa, and Alexis Conneau, “mslam: Massively multilingual joint pre-training for speech and text,” *arXiv preprint arXiv:2202.01374*, 2022.
- [43] Junyi Ao, Rui Wang, Long Zhou, Chengyi Wang, Shuo Ren, Yu Wu, Shujie Liu, Tom Ko, Qing Li, Yu Zhang,

- et al., “Speecht5: Unified-modal encoder-decoder pre-training for spoken language processing,” *arXiv preprint arXiv:2110.07205*, 2021.
- [44] Zhehuai Chen, Ankur Bapna, Andrew Rosenberg, Yu Zhang, Bhuvana Ramabhadran, Pedro Moreno, and Nanxin Chen, “Maestro-u: Leveraging joint speech-text representation learning for zero supervised speech asr,” in *2022 IEEE Spoken Language Technology Workshop (SLT)*. IEEE, 2023, pp. 68–75.
- [45] Paul K Rubenstein, Chulayuth Asawaroengchai, Duc Dung Nguyen, Ankur Bapna, Zalán Borsos, Félix de Chaumont Quitry, Peter Chen, Dalia El Badawy, Wei Han, Eugene Kharitonov, et al., “Audiopalm: A large language model that can speak and listen,” *arXiv preprint arXiv:2306.12925*, 2023.
- [46] Eliya Nachmani, Alon Levkovitch, Roy Hirsch, Julian Salazar, Chulayuth Asawaroengchai, Soroosh Mariooryad, Ehud Rivlin, RJ Skerry-Ryan, and Michelle Tadmor Ramanovich, “Spoken question answering and speech continuation using spectrogram-powered llm,” in *The Twelfth International Conference on Learning Representations*, 2024.
- [47] Itai Gat, Felix Kreuk, Tu Anh Nguyen, Ann Lee, Jade Copet, Gabriel Synnaeve, Emmanuel Dupoux, and Yossi Adi, “Augmentation invariant discrete representation for generative spoken language modeling,” *arXiv preprint arXiv:2209.15483*, 2022.
- [48] Shoval Messica and Yossi Adi, “Nast: Noise aware speech tokenization for speech language models,” *arXiv preprint arXiv:2406.11037*, 2024.
- [49] Felix Kreuk, Gabriel Synnaeve, Adam Polyak, Uriel Singer, Alexandre Défossez, Jade Copet, Devi Parikh, Yaniv Taigman, and Yossi Adi, “Audiogen: Textually guided audio generation,” *arXiv preprint arXiv:2209.15352*, 2022.
- [50] Jade Copet, Felix Kreuk, Itai Gat, Tal Remez, David Kant, Gabriel Synnaeve, Yossi Adi, and Alexandre Défossez, “Simple and controllable music generation,” *Advances in Neural Information Processing Systems*, vol. 36, 2024.
- [51] Xin Zhang, Dong Zhang, Shimin Li, Yaqian Zhou, and Xipeng Qiu, “Spechtokenizer: Unified speech tokenizer for speech large language models,” *arXiv preprint arXiv:2308.16692*, 2023.
- [52] Guy Yariv, Itai Gat, Lior Wolf, Yossi Adi, and Idan Schwartz, “Audiotoken: Adaptation of text-conditioned diffusion models for audio-to-image generation,” *arXiv preprint arXiv:2305.13050*, 2023.
- [53] Guy Yariv, Itai Gat, Sagie Benaim, Lior Wolf, Idan Schwartz, and Yossi Adi, “Diverse and aligned audio-to-video generation via text-to-video model adaptation,” in *Proceedings of the AAAI Conference on Artificial Intelligence*, 2024, vol. 38, pp. 6639–6647.