

Path-Optimal Symbolic Execution of Heap-Manipulating Programs

Pietro Braione

Giovanni Denaro

DISCo, University of Milano-Bicocca

Milano, Italy

[pietro.braione,giovanni.denaro]@unimib.it

ABSTRACT

Symbolic execution is at the core of many techniques for program analysis and test generation. Traditional symbolic execution of programs with numeric inputs enjoys the property of forking as many analysis traces as the number of analyzed program paths, a property that in this paper we refer to as path optimality. On the contrary, current approaches for symbolic execution of heap-manipulating programs fail to satisfy this property, thereby incurring heavy path explosion effects that crucially penalize the efficiency of the analysis. This paper introduces POSE, path-optimal symbolic execution, a symbolic execution algorithm that originally accomplishes path optimality against heap-manipulating programs. We formalize the POSE algorithm for a tiny, but representative object-oriented programming language, and implement the formalization into a prototype symbolic executor to experiment the algorithm against a benchmark of sample programs that take data structures as inputs. Our experiments provide initial empirical evidence of the potential of POSE for improving on the state of the art of symbolic execution of heap-manipulating programs.

KEYWORDS

Symbolic execution, Program analysis

ACM Reference Format:

Pietro Braione and Giovanni Denaro. 2024. Path-Optimal Symbolic Execution of Heap-Manipulating Programs. In XXXXXX. ACM, New York, NY, USA, 16 pages. <https://doi.org/10.1145/nnnnnnn.nnnnnnn>

1 INTRODUCTION

Symbolic execution is a well known and reputed program analysis technique. Since the seminal work of King and Clarke in the seventies [19, 35], it has been increasingly gaining momentum in both academia and industry [8, 10, 18, 41], with a plethora of effective applications for program verification [11, 20, 22, 24, 46], test case generation [2, 12, 14, 30, 38, 42, 47, 49, 52], worst case time estimation [5, 15, 40], fuzzing [48, 53], vulnerability analysis [32, 56], and many others [27, 54, 55].

In a nutshell symbolic execution consists in simulating the semantics of programs against symbolic inputs, representative of all possible input values, thereby synthesising the conditions on the input values that make given program paths execute. It exploits these *path conditions* with constraint solvers (e.g., Z3 [21]) to reason on the feasibility of the program paths [2, 9, 13, 16, 17].

To analyze *heap-manipulating programs*, which take inputs that can reference data structures in the heap memory, symbolic execution shall cope with both numeric and reference-typed inputs. Since the seminal work of Visser et al. in 2003 [34], the classic approach is to augment traditional symbolic execution with *lazy initialization* [2, 12, 13, 29, 43, 51]. Upon accessing a reference-typed input (say parameter r) for the first time, lazy initialization systematically enumerates the assumptions on how r can relate to the data structures in the initial heap: r could be null, or alias of any type-compatible input reference already considered during symbolic execution, or point to a distinct input data structure possibly containing further symbolic inputs. For each assumption, lazy initialization forks a separate analysis trace that conjoins that assumption in the path condition, to analyze how the assumption impacts at the next steps of the program. This embodiment of symbolic execution with lazy initialization is referred to as *generalized symbolic execution* [34, 45].

Lazy initialization is elegant and simple, but does not preserve the property of traditional symbolic execution of forking exactly an analysis trace for each analyzed program path. In this paper we refer to this property as *path optimality*, requiring that *the analysis traces forked during symbolic execution are isomorphic to the analyzed program paths*. Conversely, with lazy initialization, the symbolic execution of each program path forks a number of analysis traces combinatorial in the number of assumptions made while accessing heap-related inputs. This generally exacerbates, possibly to even large extents (see Section 4), the path explosion issues incurred by symbolic execution. At the state of the art, while researchers investigated some ways of improving the efficiency of the lazy initialization algorithm [22, 23, 25] (as we survey in Section 2), no existing variant of generalized symbolic execution is able (not even close) to achieve path optimality.

In this paper we introduce a novel *path-optimal symbolic execution* (POSE) algorithm for heap-manipulating programs. When the program accesses the heap via an input reference, POSE models the result with a symbolic formula that embeds all relevant assumptions on aliasing and distinctness between the input references as a single symbolic expression, by using *if-the-else* expressions. Thus, it represents the relevant assumptions precisely, but avoids forking the analysis at any step but actual decisions points of the program. We formalized POSE for a tiny object-oriented language, and implemented the formalization (in Java) into a prototype, i.e., a symbolic executor of programs in the tiny language. We then used our prototype to experience POSE against a set of subject programs. Our experiments confirm that POSE achieves path optimality,

XXX, XXXXXX, XXXXXX

2024. ACM ISBN 978-x-xxxx-xxxx-x/YY/MM...\$15.00

<https://doi.org/10.1145/nnnnnnn.nnnnnnn>

and obtains up to six orders of magnitude reduction in the number of analysis traces, with respect to the classic lazy initialization algorithm.

This paper is organized as follows. Section 2 exemplifies classic lazy initialization on a set of sample programs, to motivate our work and make the paper self-contained. Section 3 introduces POSE by example, and then presents the POSE algorithm formally. Section 4 discusses the results of a set of preliminary experiments that we executed with our prototype tool. Section 5 discusses related work. Section 6 outlines the conclusions of the paper and our plans for further research on POSE.

2 MOTIVATING EXAMPLES

In this section we motivate our work by discussing the suboptimality of the state-of-the-art symbolic execution approaches in coping with heap-manipulating programs. The mainstream approaches by which symbolic execution is generally extended to heap-manipulating programs are *lazy initialization* [33] and *lazier# initialization* [23]. Below, we introduce these two classical algorithms, and discuss their limitations (that in turn motivate our work) with reference to the three sample programs in Figure 1.

Example 1: Swap Program

In the program of Figure 1 (a), method `swap` of class `Sample` swaps the data within the receiver object (accessed in field `data`) with the data `s.data` within another `Sample` object that the method receives as parameter. The code of method `swap` consists of two possible program paths, depending on whether parameter `s` is `null`, which makes the program just skip of the swap behavior, or is not `null`, and the swapping indeed takes place. According to path optimality, we would like symbolic execution to accomplish the symbolic analysis of this program as a symbolic computation tree with exactly 2 traces, with path conditions `s == null` and `s != null`, respectively.

Lazy initialization. *Lazy initialization* works as follows: When a symbolic reference originating from an input is used for the first time during symbolic execution, a case analysis is performed and the current symbolic state is refined (“split”) based on the result of this analysis. The possible cases are: (i) the input reference may be `null`, or (ii) it may point to an object of the initial heap that is being accessed for the first time during symbolic execution (often referred to as a *fresh* object) or (iii) it may point to any of the type-compatible objects that were assumed at earlier symbolic execution steps (referred to as *aliases*).

At line 4 of program `swap` in Figure 1 (a), where the symbolic reference `s` is first used to access `s.data`, we shall consider three possible cases: `s == null`, `s` aliases the receiver object `this` (the `this` reference is initialized before all the others), or `s` points to a fresh initial object that differs from `this`. In similar fashion, upon analyzing lines 5 and 6, we must separately consider the possible initial values of reference `this.data` (i.e., `null`, alias of either `this` or `s`, or a pointer to a fresh object) and reference `s.data` (i.e., `null`, alias of either `this`, `this.data` or `s`, or a pointer to a fresh object), respectively.

An actual run of symbolic execution equipped with lazy initialization (cfr. Section 4) reveals that the analysis of program `swap`

unfolds the state space of the program as a symbolic computation tree with 21 traces, which is largely suboptimal with respect to our expectation of only 2 traces.

Lazier# Initialization. Deng et al. [23] proposed *lazier#* initialization as an optimization of the lazy initialization algorithm. In a nutshell, the idea is that the enumeration of the possible values of a input reference, rather than being done all at once as soon as the reference is accessed, can be further delayed, depending on the operations executed against the reference.

Initially, the technique represents input references by means of abstract symbolic values. It uses these abstract values directly, that is, without enumerating the alternative initializations, whenever the program simply assigns the value of a reference to a variable or to a parameter. For instance, at line 5 of program `swap` in Figure 1 (a), the symbolic value of `this.data` can be assigned to the local variable `d`, without enumerating the possible initializations thereby.

The program statements that simply compare a symbolic reference with `null`, cause the enumeration of the symbolic reference to either `null`, or a *symbolic heap location*, i.e., a symbolic value that represents a (non-`null`) location in the heap. This further mitigates path explosion. For instance, at line 4 of program `swap`, *lazier#* initialization produces only 2 traces.

Eventually, however, *lazier#* initialization may fall back to baseline lazy initialization, to execute program statements that shall access the specific heap location associated with a reference. For instance, at line 6 of program `swap`, accessing field `s.data` requires symbolic execution to explicitly discriminate whether the non-`null` value of reference `s` is or is not alias of `this`.

In total, for program `swap` *lazier#* initialization represents the state space of the program as a symbolic computation tree with 3 traces, which is only slightly suboptimal with respect to our expectation of only 2 traces, and very less suboptimal than with standard lazy initialization.

Example 2: Sum Program

We further discuss the limits of the optimizations brought by *lazier#* initialization, by exemplifying the symbolic execution of the `sum` program in Figure 1 (b). This is a straight-line program that sums the value field of three nodes. We expect that a path-optimal symbolic execution of this program accomplishes the analysis with exactly 1 trace, as there are no decision points in the programs.

Unfortunately, for this program, *lazier#* initialization falls back to exactly the same suboptimal analysis as lazy initialization. In fact, as the program accesses field `val` within the data structures associated with the inputs `s0`, `s1` and `s2`, symbolic execution shall determine the exact locations of such fields, which requires to enumerate all possible initializations of those references in turn. To read the value of field `s0.val` (line 6), the cases `s0 == null`, `s0 == this`, and `s0` fresh shall be all considered. Accessing `s1.val` and `s2.val` requires homologous initializations and the additional cases of `s1 == s0`, `s2 == s0` and `s2 == s1`. A run of symbolic execution equipped with either the *lazier#* algorithm or standard lazy initialization (cfr. Section 4) suboptimally generates a symbolic computation tree with 23 traces in both cases.

```

1  class Sample {
2  Object data;
3  void swap(Sample s) {
4  if (s != null) {
5  Object d = this.data;
6  this.data = s.data;
7  s.data = d;
8  }
9  }
10 }

```

(a)

```

1  class Sample {
2  int val;
3  Sample s0, s1, s2;
4  int sum() {
5  int sum = val;
6  sum += s0.val;
7  sum += s1.val;
8  sum += s2.val;
9  return sum;
10 }
11 }

```

(b)

```

1  class Sample {
2  int max = 4;
3  Sample next;
4  boolean hasNext() {
5  Sample s = next;
6  int i = 1;
7  while (s != null
8  && i <= max) {
9  s = s.next;
10 i = i + 1;
11 }
12 return s == null;
13 }
14 }

```

(c)

Figure 1: Sample programs

Example 3: HasNull Program

The suboptimality of classic generalized execution may exacerbate the path-explosion issues of symbolic execution to large extent. We exemplify this phenomenon with reference to the `hasNull` program of Figure 1 (c). It scans a sequence of `Sample` nodes in search for a null terminator within `max` nodes, where `max` is a constant set to 4 in the example. Since each evaluation of the loop condition at line 7 (`s != null`) generates two alternatives, one that exits the loop and returns `true`, and one that enters the next iteration, respectively, and since the fifth evaluation of the loop condition at line 8 (`i <= max`) exits the loop in any case, a path-optimal symbolic execution must yield a symbolic computation tree with exactly 6 traces.

According to lazy initialization, accessing `this.next` at line 5 requires to consider three alternatives, i.e., `this.next == null`, `this.next == this` and `this.next` fresh, respectively. Each access to `s.next` at line 9 further requires similar initializations, plus additional alias cases with respect to the incrementally considered fresh objects. Lazier# initialization achieves limited improvements, only differing in not enumerating the cases other than `s.next == null` at the fifth nesting level. In the end, the symbolic computation tree consists of 21 traces and 16 traces with lazy and lazier# initialization, respectively.

Generalizing the example for other values of the bound `max`, we observe that a path-optimal symbolic execution should analyze $O(max)$ traces, while lazy and lazier# initialization lead to analyzing $O(max^2)$ traces. Changing line 2 as `max=10` yields 78 traces (cfr. Section 4) with lazy initialization, whereas a path-optimal analysis should compute 12 traces only.

3 PATH-OPTIMAL SYMBOLIC EXECUTION

POSE is a symbolic execution algorithm for heap-manipulating programs that realizes the notion of path optimality that we introduced in Section 1. That is, POSE forks distinct analysis traces only when analysing distinct paths of the program control flow graph, i.e., program paths that mutually differ in at least one of their instructions.

POSE grounds on the intuition that most accesses that a program makes to the data structures in the heap, e.g., reading and writing values from fields of input objects, serve in the scope of sequential (non-branching) computations, such as, for computing other values, assigning some variable, dereferencing further objects, and so forth. To accomplish path-optimal symbolic execution, POSE aims to represent the effects of those instructions with comprehensively precise symbolic expressions, but avoiding to spawn distinct path conditions for any instruction that does not correspond to an actual decision point of the program. This is the distinctive characteristic of POSE with respect to the previous techniques like lazy and lazier# initialization that we surveyed in Section 2. Indeed, while programs access the heap to read and write values quite often, only occasionally those values will be participating in decision points that select the execution of distinct program paths.

In this section, we first provide an informal overview of how POSE handles the representation of the symbolic states when executing program instructions that access the data structures in the initial heap. We organize this part of the presentation around simplified examples, aiming to introduce the core technical means that comprise POSE. Then, we present the POSE algorithm formally.

3.1 Overview of POSE

Let us consider the sample program `p1` in Figure 2 (a) that accesses the input heap to read values. At line 3, the program dereferences the three objects referred by the inputs `a0`, `a1` and `a2`. If we exclude, at least at the moment, that these inputs could be null references, the computation at line 3 is strictly sequential: it reads the values from the field `f` of the three input objects, one after the other, and sums them up incrementally. The result of line 3 does indeed depend on the possibility that the references `a0`, `a1` and `a2` can be mutually alias of each other, but these possible alias relations do not themselves drive the control flow to different program branches.

Aiming to path optimality, in POSE the symbolic execution of program `p1`, line 3, leads to a single symbolic state that comprehensively represents the possible aliasings, as shown in Figure 2 (b): Variable `a0` refers to a symbolic location `A0`, in turn associated with

<pre> 1 class A {int f;} 2 int p1(A a0, A a1, A a2) { 3 int v = a0.f + a1.f + a2.f; 4 if (a0.f != a1.f) 5 abort(); 6 return v - a1.f - a2.f; 7 } </pre>	<pre> a0 := A0 → [f → I0] a1 := A1 → [f → ite(A1 = A0, I0, I1)] a2 := A2 → [f → ite(A2 = A1, ite(A1 = A0, I0, I1), ite(A2 = A0, I0, I2))] v := I0 + ite(A1 = A0, I0, I1) + ite(A2 = A1, ite(A1 = A0, I0, I1), ite(A2 = A0, I0, I2)) Σ := A0 ≠ null ∧ A1 ≠ null ∧ A2 ≠ null </pre>
(a) The sample program p1	(b) Symbolic state after line 3 of p1

Figure 2: Example on how POSE handles reading values from the heap

an object of the input heap in which the field $a0.f$ has a symbolic integer value $I0$. In turn, variable $a1$ refers to a symbolic location $A1$ associated with an object in which field $a1.f$ has two possible values, thereby defined with an *if-then-else* expression (*ite* expression), i.e., the expression $ite(A1 = A0, I0, I1)$: It represents the fact that the value of the field is the symbol $I0$ if $A1$ and $A2$ represent the same concrete location, or $a1.f$ has another independent symbolic value, $I1$, otherwise. Variable $a2$ refers to a symbolic location $A2$, and thereby to an object where the value of $a2.f$ is modeled by a composition of *ite* expressions that represent the possible alias relations between the locations $A2$, $A1$ and $A0$. Variable v evaluates to the sum of the symbolic values of the fields $a0.f$, $a1.f$ and $a2.f$.

The path condition (Σ in Figure 2 (b)) records only that the three symbolic locations $A0$, $A1$ and $A2$ correspond to actual concrete memory locations (i.e., not to $null$) which is in fact the only condition for the program to execute line 3 and proceed on. As a matter of fact, when executing program p1, any concrete assignment of the inputs $a0$, $a1$ and $a2$ with values different from $null$ will make the program execute line 3 and enter the execution of line 4, regardless how these inputs may alias between each other.

The only branching point of the program p1 in Figure 2 (a) is at line 4. It depends on the condition $a0.f \neq a1.f$, which the POSE algorithm will render as in classic symbolic execution, i.e., by evaluating the condition with respect to the symbolic values of these fields. Since the values of $a0.f$ and $a1.f$ are $I0$ and $ite(A1 = A0, I0, I1)$, respectively, this leads to line 5 being guarded by the path condition $A0 \neq null \wedge A1 \neq null \wedge A2 \neq null \wedge I0 \neq ite(A1 = A0, I0, I1)$. A constraint solver can straightforwardly compute that this path condition is satisfiable only if $A1$ and $A0$ are different. Similarly the return value at line 6 can be symbolically computed to be $I0$, with the path condition including the clause $I0 = ite(A1 = A0, I0, I1)$, satisfiable both if $A1$ and $A0$ are equal and if they are not. We observe that the path conditions to execute line 5 and line 6 do not depend on possible alias relations of $A0$ and $A1$ with respect to $A2$, which is in fact what we expect for this program.

We now elaborate on how POSE models the write accesses to the heap. We refer to the sample program p2 in Figure 3 (a) that assigns the values of the fields $b2.f$, $b1.f$ and $b0.f$ (lines 3–5) thus updating the initial values of those fields. Also, we observe that the condition at line 6 can hold true only if the references $b2$, $b1$ and $b0$ are mutually aliases, since in that case $b2.f$, $b1.f$ and $b0.f$ all refer to the same field, which is set to 0 after the latest assignment at line 5. In the same spirit of the previous example, POSE aims to model the assignments at lines 3–5 by taking track of the possible

```

1  class B {int f;}
2  void p2(B b0, B b1, B b2) {
3      b2.f = 2;
4      b1.f = 1;
5      b0.f = 0;
6      if (b0.f + b1.f + b2.f == 0) {
7          abort();
8      }
9  }

```

(a) The sample program p2

```

b2 := A2 → [f → 2]
b1 := A1
b0 := A0
Σ := A2 ≠ null

```

(b) The symbolic state after line 3 of p2

```

b2 := A2 → [f → ite(A2 = A1, 1, 2)]
b1 := A1 → [f → 1]
b0 := A0
Σ := A2 ≠ null ∧ A1 ≠ null

```

(c) The symbolic state after line 4 of p2

```

b2 := A2 → [f → ite(A2 = A0, 0, ite(A2 = A1, 1, 2))]
b1 := A1 → [f → ite(A1 = A0, 0, 1)]
b0 := A0 → [f → 0]
Σ := A2 ≠ null ∧ A1 ≠ null ∧ A0 ≠ null

```

(d) The symbolic state after line 5 of p2

Figure 3: Example on how POSE handles assigning values in the heap

alias conditions, but without spawning multiple path conditions. As above, for now, we model the case in which the three input references are not null.

The symbolic execution of program p2, line 3, leads to the symbolic state shown in Figure 3 (b): Variable $b2$ refers to the symbolic memory address $A2$, associated with a data structure in which field

f is set to 2 as result of the assignment, and both $b1$ and $b0$ are modeled as unaccessed symbolic references, not yet initialized to a corresponding object. The path condition Σ records that $A2$ must be not null, which is the requirement for accessing the field $b2.f$.

Then, when executing line 4 `POSE` updates the symbolic state as shown in Figure 3 (c): The value of variable $b1$ reflects the assignment of $b1.f$ to 1, and the value of $b0.f$ reflects that also $b0.f$ would be updated, if the symbolic locations $A1$ and $A2$ were alias of each other. In `POSE`, when updating a field in an object associated to a symbolic memory address ($A1$ in the example), we also update all the same fields in the type-compatible objects stored at symbolic locations that belong to the same symbolic state. In the example, since $A1$ and $A2$ represent type-compatible input references, they might be alias in the input state: if so, the assignment of $A1.f$ entails also the assignment of $A2.f$. Thus, `POSE` models $A2.f$ as an *ite* expression $ite(A2 = A1, 1, 2)$ that reflects the assignment to 1 in case of aliasing between $A2$ and $A1$, or the previous value of the field, 2, if $A2$ and $A1$ differ. The path condition records the assumption that $A1$ is not null, for $b1.f$ to be successfully accessed.

Proceeding in this way, after line 5 we get the symbolic state shown in Figure 3 (d): Variable $b0$ refers to the symbolic location $A0$ with field f assigned to 0, and the type-compatible input objects pointed by the symbolic locations $A1$ and $A2$ are updated with *ite* expressions to model the effects of the possible alias relations between $A1$ and $A0$, and between $A2$ and $A0$, respectively. The path condition now records that also $A0$ must be not null.

Eventually, at line 6, `POSE` proceeds by evaluating the condition for the branching point based on the symbolic state computed as above. This leads to computing the path condition for the execution at line 7 based on symbolic values of the three fields, which is then: $A2 \neq null \wedge A1 \neq null \wedge A0 \neq null \wedge ite(A2 = A0, 0, ite(A2 = A1, 1, 2)) + ite(A1 = A0, 0, 1) + 0 = 0$. It can be easily verified that this path condition is satisfiable when $A0$, $A1$ and $A2$ are alias of the same non-null concrete location, which indeed is what characterizes the input states that execute the program up to line 7.

Finally, going back to the possibility that the inputs of programs $p1$ and $p2$ could be null references, we remark that those cases correspond to distinct control flow paths of the two programs, namely, the paths in which the two programs raise specific exceptions for the given null-pointers. Thus, `POSE` analyzes those paths in separate traces as with classic lazy initialization.

3.2 Formalization of `POSE`

We formalized the `POSE` algorithm for imperative, object-oriented programming languages. Without loss of generality, our formalization refers to a tiny language that models a program as a sequence of classes and their methods, with single-class inheritance. The tiny language includes instructions for instantiating new objects, reading and assigning their fields, structuring the control flow with *if*-statements and method calls, and operating with expressions on references, integers and booleans. The tiny language does not have loop statements, but iterative computations can be anyway defined via recursion. Later (Section 4) we discuss how we exploited our formalization to evaluate the `POSE` algorithm against a set of sample programs.

For any expression η of the tiny language, where η could be for example a *getfield* or a *putfield* expression, we formalize the small-step operational semantics as

$$\text{Step:} \frac{H \Sigma \eta \rightsquigarrow^* H' \Sigma' \eta \quad H' \Sigma' \eta \rightarrow H'' \Sigma'' \eta''}{H \Sigma \eta \Rightarrow H'' \Sigma'' \eta''}$$

where H, H', H'' are heaps, $\Sigma, \Sigma', \Sigma''$ are path conditions, and η'' is the result obtained by reducing the expression η . The step relation (\Rightarrow) is the suitable composition of two transition relations: the (reflexive-transitive closure of the) *refinement* transition relation \rightsquigarrow^* , which augments $H \Sigma$ with the relevant assumptions needed to reduce the expression at hand, leading to $H' \Sigma'$; and the *computation* transition relation \rightarrow , which further processes the symbolic configuration to reflect the side effects of reducing the expression η to η'' , leading to the final configuration $H'' \Sigma'' \eta''$.

Below we discuss the formalization of `POSE` in particular for the expressions that read and write the content of object fields, i.e., expressions like $\sigma.f$ and $\sigma.f := \sigma'$, where σ is either a concrete or a symbolic reference value. As explained above, those are the expressions for which the symbolic execution according to `POSE` distinctively differs from generalized symbolic execution based on classic lazy initialization. Furthermore, we also discuss the handling of conditional statements that predicate over references and method calls, whose semantics relates to subexpressions that may include symbolic references.

We initially present the formalization of these expressions by referring to the tiny language without inheritance, and then discuss the handling of inheritance at the end of this section. The complete definition of the `POSE` algorithm is provided as Appendix A in the supplemental material of this paper.

Getfield expressions. Figure 4 presents the formalization of *getfield* expressions, i.e., expressions in the form $\sigma.f$, being σ a symbolic reference value, and f a field declared for a given class. As a result of evaluation, σ could be a concrete reference, a plain symbolic reference, or a symbolic expression over reference values. In the former case the evaluation falls back to concrete execution. The figure shows the other two cases, indicated as rules *Getfield* (c1) and *Getfield* (c2), respectively. *Getfield* (r1) and *Getfield* (r2) formalize the related refinement steps.

Rule *Getfield* (c1) considers the case where σ is a symbolic reference Y . The rule may fire only if the current configuration was suitably refined earlier in the symbolic execution: A symbolic object for Y must exist in the heap ($Y \in \text{dom}(H)$), and the the field f must have some (possibly symbolic) value ($H(Y)(f) \neq \perp$). If such conditions are met, the value is read from the object field $H(Y)(f)$ leading to the transition $H \Sigma Y.f \rightarrow H \Sigma H(Y)(f)$.

The refinement steps, *Getfield* (r1) and *Getfield* (r2), handle the assumptions needed to bind a symbolic reference Y being accessed to a properly initialized object in the initial heap. In `POSE`, each symbolic reference is initially represented as a free symbolic value, which may not necessarily be bound to any object of the initial heap. In fact the actual value of an input reference could be null in the initial state. However, when we assume the successful reduction of a *getfield* expression, we shall assume that the corresponding reference was bound to to a *symbolic object* in the initial heap.

$$\begin{array}{c}
\text{Getfield (c1): } \frac{Y \in \text{dom}(H) \quad f \in \text{dom}(H(Y)) \quad H(Y)(f) \neq \perp}{H \Sigma Y.f \rightarrow H \Sigma H(Y)(f)} \\
\\
\text{Getfield (c2): } \frac{H \Sigma \sigma_1.f \Rightarrow H'_1 \Sigma'_1 \sigma'_1 \quad H \Sigma \sigma_2.f \Rightarrow H'_2 \Sigma'_2 \sigma'_2 \quad H' = \text{mergeHGf}(H'_1, H'_2, f) \quad \Sigma' = \text{mergePC}(\sigma, \Sigma'_1, \Sigma'_2)}{H \Sigma \text{ite}(\sigma, \sigma_1, \sigma_2).f \rightarrow H' \Sigma' \text{ite}(\sigma, \sigma'_1, \sigma'_2)} \\
\\
\text{Getfield (r1): } \frac{Y \notin \text{dom}(H)}{H \Sigma Y.f \rightsquigarrow H, Y \mapsto (\text{fields}(\text{class}(f)) \mapsto \perp) \Sigma, \neg Y = \text{null}, Y.f} \\
\\
\text{Getfield (r2): } \frac{Y \in \text{dom}(H) \quad H(Y)(f) = \perp \quad Z \text{ fresh}}{H \Sigma Y.f \rightsquigarrow H[Y \mapsto H(Y)[f \mapsto \text{assume}(H, Y, f, Z)]] \Sigma, Y.f = Z Y.f}
\end{array}$$

Figure 4: Small-step operational semantics for getfield expressions

The refinement steps materialize this initial object, along with the assumption on the reference to be not null.

In detail, the rules Getfield (r1) and Getfield (r2) specify the refinements to associate the reference Y to a symbolic object, and the field $Y.f$ to a value, respectively, in the cases when those initializations are needed. Rule Getfield (r1) handles the situation where a symbolic reference has no corresponding symbolic object in the heap yet—i.e., is *unbound*. The refinement step adds a symbolic object in which all fields are not yet initialized (indicated as the value \perp of the fields), binds Y to the new object, and suitably updates the path condition by adding the assumption that $Y \neq \text{null}$.

Rule Getfield (r2) handles the access to an uninitialized field ($H(Y)(f) = \perp$) by initializing it with either a fresh symbolic value Z (if Y denotes a fresh object) or the value of the same field of another, type-compatible symbolic object (if Y is alias of this object). Differently from lazy initialization, where all these alternative initializations for Y would lead to branching the current symbolic state, in POSE they are encoded within the symbolic value of the field, by means of an *ite*-expression, indicated in the refinement rule by *assume*(H, Y, f, Z). This predicate represents the possible alias relations between $Y.f$ and the field $Y'.f$ of other already bound and compatible objects, formally:

$$\begin{aligned}
\text{assume}(H, Y, f, Z) &= \text{ite}(Y = Y_1, H(Y_1)(f), \dots, \\
&\quad \text{ite}(Y = Y_m, H(Y_m)(f), Z) \dots)
\end{aligned}$$

where $\{Y_1 \dots Y_m\} = \{Y' \in \text{dom}(H) \mid Y' \neq Y \wedge f \in \text{dom}(H(Y')) \wedge H(Y')(f) \neq \perp\}$ is the *alias set* of Y , and is composed by the set of all the bound symbolic references that point to a type-compatible object in which field f already incurred initialization. The symbolic value Z stands for the initial value of $Y.f$, which is a fresh symbolic value if $Y.f$ is not alias with respect to other symbolic references considered so far. The *assume*(H, Y, f, Z) value that is assigned to the $Y.f$ field reflects the possible current value of the field: For all Y_i , if Y aliases Y_i , then $Y.f$ has the same value stored in $Y_i.f$; otherwise, if Y does not alias any object in its alias set, then $Y.f$ is the unmodified initial value Z .

Figure 2, which we already discussed above, exemplifies the application of rules Getfield (c1), Getfield (r1) and Getfield (r2) to a sample program.

The rule Getfield (c2) copes with *ite*($\sigma, \sigma_1, \sigma_2$) symbolic references. These symbolic references may emerge as expressions of

alias conditions and are handled by reading the field f from the objects denoted by the expressions σ_1 and σ_2 , and returning the *ite* of the results.

Putfield expressions. Figure 5 presents the computation semantics of field assignment expressions, $\sigma.f := \sigma'$, in the cases where σ is either a plain symbolic reference Y (rule Putfield (c1)) or a symbolic expression over references values *ite*($\sigma, \sigma_1, \sigma_2$) (rule Putfield (c2)), respectively. Rule Putfield (c1) is for updating a field of an object accessed via a symbolic reference Y . The update can be performed only if Y is bound and the symbolic object has field f , which may require refinement Putfield (r1) to bound Y to an input object, in the same fashion as the refinement Getfield (r1) described above. The effect of a field update does not necessarily affect only the symbolic object bound to Y : It may also affect all the symbolic objects in the alias set of Y . Formally the impact of the update on the alias set is described by as the heap $H_r = \text{update}(H, Y, f, \sigma')$, where

$$\begin{aligned}
\text{dom}(H_r) &= \text{dom}(H) \wedge \forall u' \in \text{dom}(H), f' \in \text{dom}(H)(Y') \mid \\
&\quad u' = Y' \wedge Y' \neq Y \wedge f' = f \wedge H(Y')(f) \neq \perp \\
&\implies H_r(u')(f') = \text{ite}(Y = Y', \sigma', H(u')(f')) \wedge \\
&\quad \neg(u' = Y' \wedge Y' \neq Y \wedge f' = f \wedge H(Y')(f) \neq \perp) \\
&\implies H_r(u')(f') = H(u')(f').
\end{aligned}$$

Informally, if Y' is a bound symbolic reference to a type-compatible object, whose f field is initialized, the field $Y'.f$ must also be updated to an *ite* reflecting the potential alias relation: If Y aliases Y' , then $Y'.f$ also assumes the value assigned to $Y.f$, otherwise it retains its current value.

Figure 3, which we already discussed above, exemplifies the application of rules Putfield (c1) and Putfield (r1) to a sample program.

The rule Putfield (c2) handles the case where an *ite*($\sigma, \sigma_1, \sigma_2$) symbolic reference is used to refer the object to be updated. The effect on the heap and on the path condition is defined in terms of a suitable merging between the effects of updating the objects referred by σ_1 and σ_2 respectively.

Conditional expressions. The POSE semantics for conditional expressions that depend on conditions that predicate on references is straightforward. The only allowed comparisons between references are equality and equality to null. This gives rise to three possible cases: Either two symbolic references are compared for equality, or

$$\begin{array}{c}
\text{Putfield (c1): } \frac{Y \in \text{dom}(H) \quad H_r \equiv \text{update}(H, Y, f, \sigma')}{H \Sigma Y.f := \sigma' \rightarrow H_r[Y \mapsto H(Y)[f \mapsto \sigma']] \Sigma \sigma'} \\
\\
\text{Putfield (c2): } \frac{H \Sigma \sigma_1.f := \sigma' \Rightarrow H'_1 \Sigma'_1 \sigma' \quad H \Sigma \sigma_2.f := \sigma' \Rightarrow H'_2 \Sigma'_2 \sigma' \quad H' = \text{merge}(H'_1, H'_2, H, f, \sigma, \Sigma'_1, \Sigma'_2) \\ \Sigma' = \text{mergePC}(\sigma, \Sigma'_1, \Sigma'_2), \text{mergeClauses}(H'_1, H'_2, H, f, \sigma, \Sigma'_1, \Sigma'_2)}{H \Sigma \text{ite}(\sigma, \sigma_1, \sigma_2).f := \sigma' \rightarrow H' \Sigma' \sigma'} \\
\\
\text{Putfield (r1): } \frac{Y \notin \text{dom}(H)}{H \Sigma Y.f := \sigma' \rightsquigarrow \dots \text{ same as Getfield (r1) in Figure 4}}
\end{array}$$

Figure 5: Small-step operational semantics for putfield expressions

a symbolic reference is compared for equality against a concrete reference, or a symbolic reference is compared for equality against null. In all cases, POSE will simply conjoin the evaluated condition to the current path condition, either as it is or after negating it (according to the taken branch), regardless of whether or not those symbolic references were bound to objects.

If the path condition includes other values that depend on alias conditions with the references that belong to the new clause, the new clause will impact on the solutions of those values, possibly causing contradictions (infeasible branches), as usual for branching statements in symbolic execution.

Method invocations. If we do not consider inheritance, handling method invocation expressions $Y.m(\dots)$ requires only to update the path condition with the assumption on the value of Y not to be null. Then the execution proceeds on the first instruction of m .

Inheritance and polymorphism. The POSE approach to handling inheritance and polymorphic object’s dereferencing is based on the classic approach of predicating type-order relations over the types of the input objects, according to the partial order between object types defined in the inheritance tree [23, 39].

While symbolically executing accesses to fields, POSE handles information on the type of the symbolic objects that are materialized. The complete forms of the rules Getfield (r1) and Putfield (r1), as reported in Appendix A, add to the path condition assumptions with shape $Y \leq: c$, signifying that the symbolic object referred by Y has a type that is “*more specialized than or the same as*” class c (i.e., the class that declares the field). Additional rules handle the case where the field being accessed belongs to a subtype of the currently assumed type for the symbolic object: Then, the object type is further refined in the path condition, and the missing fields are added to the symbolic object.

The semantics of method invocations is the most impacted. With inheritance and polymorphism, a method invocation executed on a symbolic object generates a separate trace for each possible implementation of the method. This is consistent with the path optimality aim of POSE, since each trace executes a distinct program path, which flows through a distinct implementation of the target method. In each trace the path condition is predicated by the assumption that the type of the receiver object is more specialized than the class that specifies the method’s implementation and is not more specialized than the subclasses (if any) that override the implementation. Notably, some assumptions done upon calling subsequent

methods along the same path can result in contradictions on the type assumptions, when the call of the former method assumed a subtype that is incompatible with the latter method.

An in-depth presentation of symbolic execution with symbolic object types is out of the scope of this paper. We refer the reader to previous work from Deng et al. and Li et al. for the details [23, 39].

4 EVALUATION

We implemented a prototype of a POSE-based symbolic executor that accepts programs written in the tiny imperative object-oriented language for which we formalized POSE. The prototype interprets the programs syntactically, unfolding the symbolic states of the symbolic computation tree in breath-first order. It is written in Java and integrates with the Z3 SMT solver [21] to prune the symbolic states with unsatisfiable path conditions. We used the prototype to crosscheck the consistency of the formalization and simulate the POSE algorithm against a set of subject programs, aiming to a proof-of-concept of the POSE idea.¹

4.1 Research Questions and Experiment Setting

We aimed to answer the following research questions:

- RQ1** To what extent does POSE make symbolic execution fork less analysis traces than symbolic execution equipped with classic lazy initialization?
- RQ2** To what extent does POSE make symbolic execution incur less constraint solving load than symbolic execution equipped with classic lazy initialization?
- RQ3** Can we reject the null-hypothesis that the amount of constraint solving load of POSE and lazy initialization is equivalent? This question follows up on RQ2, reflecting on the possible criticism that POSE encodes multiple path conditions into single ite formulas, but shall in fact solve the same set of path conditions as lazy initialization.

The research question RQ1 addresses the main hypothesis of this paper, that is, that POSE is effective for mitigating the path explosion issues of symbolic execution of heap manipulating programs caused by the lazy initialization algorithm. We answer RQ1 by measuring the number of analysis traces that symbolic execution forks when working either according to POSE or based on classic lazy initialization, respectively, for a set of subject programs. As

¹The POSE prototype and the replication package of our experiments are available at <https://github.com/pietrobraione/jpose>.

we already showed in the examples of Section 2, POSE enjoys the property of forking exactly an analysis trace for each analyzed program path. By studying RQ1, we aim to quantify in further detail the improvement that results from addressing this property, with respect to the classic setting in which symbolic execution relies on lazy initialization.

Forking a path-optimal number of analysis traces can be per-se a relevant improvement in many common applications of symbolic execution, as it directly relates with the amount of cognitive load required to exploit the result of symbolic execution. For example, when using symbolic execution for path-driven test generation (as for example in dynamic symbolic execution [2, 30, 44]), the number of analysis traces corresponds to the number of test cases to be instantiated and executed during the overall test generation process.

Nonetheless, another important research question is whether POSE can improve the efficiency of symbolic execution. In fact, a reduced number of analysis traces directly maps to less satisfiability queries to be sent to the constraint solver, and it is common knowledge that the time spent for constraint solving dominates the time requirements of symbolic execution [3, 4, 17, 50].

The research question RQ2 aims to quantify the reduction of the constraint solving costs when using POSE rather than lazy initialization. We answer RQ2 by comparing the number of queries that symbolic execution issues for constraint solving, either with POSE or lazy initialization, respectively.

The constraint solving costs could also be evaluated by measuring the time budget consumed for constraint solving. However, we observe that in our experimental setting, a time-based evaluation would most likely be biased by the significant differences, in both maturity and technical means, between the symbolic executors that we use for executing POSE and lazy initialization, respectively. To collect the data on lazy initialization, we executed Java versions of the subject programs with the symbolic executor JBSE [13] that handles symbolic references according to classic lazy initialization [34]. JBSE is a long-standing, well-engineered symbolic executor that analyzes programs in Java bytecode at low level, and of course it is very much faster than our current, proof-of-concept-only prototype of POSE. Moreover, a major difference is that JBSE uses the incremental mode of the constraint solver Z3, by pushing and popping path condition clauses incrementally while exploring the program paths in depth-first order, whereas the POSE prototype uses Z3 by sending any query as its corresponding entire formula, which makes the solving time largely impacted by the time for transferring the large formulas to the constraint solver. Thus, it makes little sense to compare the execution time of the tools.

The research question RQ3 follows up on the efficiency of POSE, also in the light of the above observation about missing a time-based evaluation, by diving into the different complexity of the constraint solving queries generated with POSE and lazy initialization, respectively. POSE issues queries that enclose multiple alias conditions into single ite formulas, whereas lazy initialization focuses separately on each alias condition in a dedicated analysis trace, which results in issuing a larger set of simpler queries. This leads to questioning whether having to solve a smaller set of complex queries (as in the case of POSE) could be ultimately comparable, efficiency-wise, to solving a larger set of simple queries.

To investigate RQ3, we adapted the POSE prototype such that it queries the constraint solver after unwinding the ite formulas of the path conditions into disjunctions of subformulas without ite expressions. More in detail, the adapted prototype encodes the path conditions as binary decision diagrams, with respect to the atomic predicates in each path condition formula. Upon querying the constraint solver, it exploits the binary decision diagram representation to enumerate the no-ite subformulas that disjunctively constitute each path condition. Then, it issues a constraint solving query for each incrementally enumerated subformula, and either stops at the first subformula that the solver confirms to be satisfiable (a satisfiable disjunct entails that the current path condition is in fact satisfiable) or confirms that all subformulas are unsatisfiable (and so is the path condition). Hereon we use the name *POSE-unwind* to refer to the version of POSE adapted according the ad-hoc constraint solving mechanism described in this paragraph.

We answer RQ3 by comparing the number of queries that symbolic execution issues for constraint solving, either with *POSE-unwind* or lazy initialization, respectively.

In fact there are two effects that make both POSE and *POSE-unwind* induce lower constraint-solving load than lazy initialization. An effect is that, even though each POSE-style path condition generally encodes multiple lazy-initialization-style path conditions, the constraint solver can most often exploit the ite expressions to optimize the solving process, by conveniently focusing on some *satisfiable subformula* that is sufficient to decide that the overall formula is satisfiable. The POSE symbolic executor is interested in the executability of the program paths, regardless of which alias conditions could be chosen to demonstrate those program paths. *POSE-unwind* exploits the decomposition of the constraint solving problems across distinct alias conditions, to estimate the number of no-ite formulas to be considered to find a satisfiable subformula, if any. On one hand, *POSE-unwind* issues constraint solving queries comparable, complexity-wise, to the ones issued when working with lazy initialization. On the other hand, *POSE-unwind* yields a conservative approximation on the optimization opportunities, as most likely the constraint solver can exploit the optimization opportunities even better when reasoning on the entire formula at once (as in POSE) with respect to processing each subformula separately (as in *POSE-unwind*).

A second effect is that POSE forks the execution only at program's decision points (e.g., at if statements), meaning that, in some cases, accessing a reference for computation purposes (e.g., to compute some arithmetic expression) does not necessarily produce constraint solving problems with respect to the alias conditions of the reference. We discussed an exemplary case with reference to the sample program of Figure 1 (b). Thus, some of the constraint solving queries issued with lazy initialization may not appear in POSE, and this is supported by the results that we report with *POSE-unwind*.

4.2 Subjects Programs

We executed POSE against 21 programs, namely, the three synthetic sample programs that we discussed in Section 2, a variant of the sample program `hasNull` of Figure 1 (c) that executes up to ten loop iterations (i.e., we changed line 2 as `max=10`), and 17 programs that implement the access to classic data structures, i.e., AVL trees

Table 1: Analysis traces and constraint solver queries

Subject	#traces			#queries		
	POSE	POSE-unwind	Lazy init	POSE	POSE-unwind	Lazy init
Fig. 1 (a)	2	2	21	2	2	27
Fig. 1 (b)	1	1	23	0	0	30
Fig. 1 (c) max = 4	6	6	21	10	10	25
Fig. 1 (c) max = 10	12	12	78	22	22	88
avl_balanced	89	89	18,876	225	1325	37,867
avl_find	190	190	896	378	590	1,952
avl_findMax	13	13	92	25	25	104
avl_findMin	13	13	92	25	25	104
avl_insertElem	549	549	7,033	2,814	14,099	35,659
avl_maxElement	51	51	72,230,358	92	92	85,641,133
avl_minElement	51	51	72,230,358	92	92	85,641,133
dll_add	7	7	312	12	12	490
dll_get	6	6	116	10	10	138
dll_getFirst	2	2	12	2	2	16
dll_getLast	2	2	12	2	2	16
dll_indexOf	42	42	332,856	74	74	379,774
dll_remove	10	10	949	15	15	1,089
dll_removeFirst	2	2	91	2	2	119
dll_removeLast	2	2	91	2	2	119
ncll_add	2	2	108	2	2	156
treemap_put	55	55	350	183	265	533

(7 access methods out of class `AvlTree` [28]), circular linked lists (8 access methods out of class `DoubleLinkedList` [26]), red-black trees (method `put` of class `TreeMap` [26]), and caching linked lists (method `add` of class `NodeCachingLinkedList` [28]). We manually translated the original Java implementation of the data structure programs in the tiny language supported by our prototype. The first column of Table 1 lists the subject programs.

4.3 Results

4.3.1 RQ1: Number of Analysis Traces. Table 1, columns *#traces*, report the number of analysis traces forked during symbolic execution, with `POSE`, `POSE-unwind` and lazy initialization, respectively, for each subject program. By construction `POSE` and `POSE-unwind` yield exactly the same sets of analysis traces, as `POSE-unwind` differs from `POSE` only in the way it interacts with the constraint solver at each query.

The counting of the analysis traces of `POSE` for the first three subjects in the table confirm that `POSE` satisfies the path optimality requirements that we discussed for the sample programs of Section 2. In general, for all subjects, the data in the table confirm the expectation that `POSE` incurs the analysis of very much less traces than lazy initialization. The reduction is of one or two orders of magnitude in most cases. Four experiments (`avl_balanced`, `avl_maxElement`, `avl_minElement` and `dll_indexOf`) provide strong evidence of our claim that the path explosion incurred with lazy initialization can grow up to massive amounts, such as 3, 4 or even 6 orders of magnitude higher than the number of actual program paths.

For instance, `avl_maxElement` compares the element in a node with the maximum elements determined by recursing in the left and right subtrees. Thus, at each recursion step, lazy initialization

incurs the enumeration of the combinations between the possible aliases of references `left` and `right` (links to the left and right subtrees, respectively) and the combinations of the corresponding recursive subpaths thereby. With `POSE`, the aliases are not enumerated, shrinking each recursion step at only the program paths in the code, and thus controlling for growth of the combined paths.

In summary the experimental data testify the benefits brought by `POSE` in mitigating the path explosion effects of generalized symbolic execution, with respect to the classical embodiment based on lazy initialization.

4.3.2 RQ2: Constraint Solving Load. Table 1, columns *#queries*, report the number of queries sent to the constraint solver, with `POSE`, `POSE-unwind` and lazy initialization, respectively. The comparison of the number of queries for `POSE` and lazy initialization, respectively, indicates that `POSE` consistently brings a reduction of comparable amounts with respect to the reduction that it brings on the number of paths. This is not particularly surprising, as the number of constraint solving queries directly maps to the number of decision points in the program paths.

4.3.3 RQ3: Constraint Solving Load “Reloaded”. We referred to the `POSE-unwind` adaption of our prototype to transpose the multi-alias, ite-based constraint solving queries generated by `POSE` into sets of disjunctive, non-ite sub-formulas, each of comparable complexity as the queries generated by JBSE via lazy initialization. Comparing the values of the number of constraint solving queries that occur with `POSE-unwind` and lazy initialization, respectively, allows us to quantify (a conservative lower bound of) the difference in the number of *equivalent constraint solving queries* required with `POSE` and lazy initialization, respectively.

The data indicate that the number of queries with POSE-unwind is exactly the same that we observed with POSE for 17 out of 21 subjects, including the subjects `avl_maxElement` and `avl_minElement` in which POSE-unwind queries the constraint solver on 92 formulas, whereas lazy initialization issues more than 85 million queries. This result indicates that, for all POSE-style path conditions of those 17 programs, the first non-ite, disjunctive sub-formula enumerated with POSE-unwind always sufficed for confirming that the path condition at hand was satisfiable. In turn, this supports our intuition that most ite-based path conditions that stem from POSE may allow convenient formula manipulations at the constraint solver side.

POSE-unwind incurs more constraint solving queries than POSE for four subjects, i.e., `avl_balanced`, `avl_find`, `avl_insertElem` and `treemap_put`. Nonetheless, it consistently scores a relevant reduction of the constraint solving load, at minimum (`treemap_put`) halving the constraint solving load of lazy initialization.

In summary our experimental data on RQ2 and RQ3 testify that POSE has potential for crucially improving the efficiency of symbolic execution by reducing the constraint solving load of the analysis.

4.4 Threats to Validity

The internal validity of our results can be threatened by possible differences in the programs that we analyzed with JBSE and the POSE prototype, respectively. JBSE analyzes the bytecode compiled from the original Java code of each program, whereas the POSE prototype required us to translate each program in the tiny language accepted by the prototype. To defend against this threat, we took maximum care in insuring that the tiny-language programs have exactly the same control flow of the corresponding bytecode programs: We organized the code with the same variables, computation sequences, and decision points; We turned the composite conditions into sequential evaluations of elementary conditions, according to the short circuit evaluation semantics exploited in the bytecode; We referred to standardized program transformations to translate the loops into recursive call structures in the tiny-language programs.

We did not engage in a direct comparison with `lazier#` initialization [23], as we have no public access to a symbolic executor that implements `lazier#` initialization. In Section 2 we exemplified that `lazier#` initialization easily falls back to lazy initialization for programs that access the data stored the fields of the input data structures, as in fact it occurs in the subject programs that we considered. Thus, we expect that the results that we computed with JBSE for those subjects can extend with minor changes to the case of generalized symbolic execution based `lazier#` initialization.

We also manually confirmed that the numbers of analysis traces that our POSE prototype produced for each subject program correspond to the expected path-optimal number of control flow paths, to crosscheck the reliability of the POSE prototype.

With respect to external validity, we are aware that our current results cannot be directly generalized, due to the limited benchmark of programs that we were able to analyze with POSE. In turn, this is due to the technical limits of our prototype, both because it is hard to translate arbitrary programs into the tiny language of the prototype, and because the the prototype has insufficient performance for analyzing large programs. As we already commented, we regard to our current results as a proof of concept of the POSE idea. We are

currently working for integrating POSE into a mainstream symbolic executor, e.g., either JBSE [13] or Symbolic JPF [2], in order to perform extensive experiments.

5 RELATED WORK

We already commented in Section 2 on the relations between POSE and the previous work on generalized symbolic execution based on *lazy initialization* [22, 23, 25, 33]. Lazy initialization dictates the brute force enumeration of the heap objects that can bind to the program inputs. It straightforwardly augments classic symbolic execution for handling heap manipulating programs, but can heavily exacerbate the path explosion issues of symbolic execution. We provided empirical evidence of this phenomenon in Section 4. POSE does not incur any additional path enumeration other than the symbolically-feasible paths of the program’s control flow graph, maintaining the *path optimality* property.

POSE is also related to existing research on using *state merging* to alleviate the path explosion issues of symbolic execution. State merging techniques merge together multiple symbolic states at suitable points of the program’s control flow, to reduce the amount of analysis traces analyzed thereon [6, 7, 31, 36, 37]. Among the many proposals, researchers investigated the selection of merge points based on fan-in [36], configurable merge points [6], on-the-fly identification of merging opportunities [37], state subsumption checking [1]. POSE and state merging both exploit ite expressions to summarize multiple symbolic states.

POSE targets the optimization of analysis traces that relate with accessing the heap memory via input pointers, according to the possible alias relations between the pointers. To the best of our knowledge, no previous state merging technique has addressed this specific goal. POSE distinctively differs from state merging also in technical means. POSE prevents path enumeration ex-ante, avoiding to spawn multiple analysis traces while symbolically executing statements that depend on input pointers. It can directly discriminate merging actions that apply to the symbolic values of the program variables, but do not necessarily affect the path conditions (if those variables do not participate in decision conditions thereon). State merging identifies merging opportunities ex-post, after having computed a group of mergeable symbolic states along distinct analysis traces. For state merging techniques, it can be sometimes hard to clean up the path conditions from clauses that accumulate to tautologies due to the merging of the path conditions that were computed in separate analysis traces, possibly resulting in unnecessarily long path conditions. POSE and state merging technique may be also used in synergistic fashion.

6 CONCLUSIONS

Current approaches to symbolic execution of heap-manipulating programs exacerbate the path explosion problem as they fork many more execution traces than the number of control flow paths in the program under analysis. This paper presented a novel approach, POSE, that keeps the number of program traces explored by symbolic execution isomorphic to the number of analyzed program paths. Our experiments, executed with a prototype implementation of POSE, provide initial empirical support for our research hypothesis

that POSE can crucially improve the efficiency of symbolic execution for heap-manipulating programs. We are currently working to integrate POSE with a mainstream symbolic executor, e.g., JBSE or Symbolic JPF, to enable more conclusive experiments. We also aim to investigate how to integrate POSE with state merging techniques.

REFERENCES

- [1] Anand, S., Păsăreanu, C.S., Visser, W.: Symbolic execution with abstract subsumption checking. In: Proceedings of the 13th International Conference on Model Checking Software. pp. 163–181. SPIN'06, Springer-Verlag, Berlin, Heidelberg (2006)
- [2] Anand, S., Păsăreanu, C.S., Visser, W.: JPF-SE: A Symbolic Execution Extension to Java PathFinder. In: International Conference on Tools and Algorithms for Construction and Analysis of Systems (TACAS). pp. 134–138 (2007)
- [3] Aquino, A., Bianchi, F.A., Meixian, C., Denaro, G., Pezzè, M.: Reusing constraint proofs in program analysis. In: Proceedings of the International Symposium on Software Testing and Analysis. pp. 305–315. ISSTA '15, ACM (2015)
- [4] Aquino, A., Denaro, G., Pezzè, M.: Reusing solutions modulo theories. *IEEE Transactions on Software Engineering* **47**(5), 948–968 (2021). <https://doi.org/10.1109/TSE.2019.2898199>
- [5] Aquino, A., Denaro, G., Salza, P.: Worst-Case Execution Time Testing via Evolutionary Symbolic Execution. In: International Symposium on Software Reliability Engineering (ISSRE). pp. 76–87 (Oct 2018)
- [6] Arons, T., Elster, E., Ozer, S., Shalev, J., Singerman, E.: Efficient symbolic simulation of low level software. In: Proceedings of the Conference on Design, Automation and Test in Europe. p. 825–830. DATE '08, Association for Computing Machinery, New York, NY, USA (2008). <https://doi.org/10.1145/1403375.1403577>
- [7] Babić, D.: Exploiting Structure for Scalable Software Verification. Ph.D. thesis, University of British Columbia, Vancouver, Canada (2008)
- [8] Baldoni, R., Coppa, E., D'Elia, D.C., Demetrescu, C., Finocchi, I.: A survey of symbolic execution techniques. *ACM Comput. Surv.* **51**(3) (2018)
- [9] Baluda, M., Denaro, G., Pezzè, M.: Bidirectional symbolic analysis for effective branch testing. *IEEE Transactions on Software Engineering* **42**(5), 403–426 (2016)
- [10] Braione, P., Denaro, G., Mattavelli, A., Vivanti, M., Muhammad, A.: Software Testing with Code-Based Test Generators: Data and Lessons Learned from a Case Study with an Industrial Software Component. *Software Quality Journal* **22**(2), 311–333 (Jun 2014)
- [11] Braione, P., Denaro, G., Pezzè, M.: Enhancing symbolic execution with built-in term rewriting and constrained lazy initialization. In: Proc. of the 2013 9th Joint Meeting on Foundations of Software Engineering. pp. 411–421. ESEC/FSE 2013, ACM, New York, NY, USA (2013). <https://doi.org/10.1145/2491411.2491433>
- [12] Braione, P., Denaro, G., Pezzè, M.: Symbolic Execution of Programs with Heap Inputs. In: ACM Joint European Software Engineering Conference and Symposium on the Foundations of Software Engineering (ESEC/FSE). pp. 602–613 (2015)
- [13] Braione, P., Denaro, G., Pezzè, M.: JBSE: A Symbolic Executor for Java Programs with Complex Heap Inputs. In: ACM Joint European Software Engineering Conference and Symposium on the Foundations of Software Engineering (ESEC/FSE). pp. 1018–1022 (2016)
- [14] Bucur, S., Ureche, V., Zamfir, C., Candea, G.: Parallel symbolic execution for automated real-world software testing. In: Proceedings of EuroSys 2011. ACM (2011)
- [15] Burnim, J., Juvekar, S., Sen, K.: WISE: Automated Test Generation for Worst-Case Complexity. In: IEEE/ACM International Conference on Software Engineering (ICSE). pp. 463–473 (2009)
- [16] Burnim, J., Sen, K.: Heuristics for Scalable Dynamic Test Generation. In: IEEE/ACM International Conference on Automated Software Engineering (ASE). pp. 443–446 (2008)
- [17] Cadar, C., Dunbar, D., Engler, D.: KLEE: Unassisted and Automatic Generation of High-coverage Tests for Complex Systems Programs. In: Symposium on Operating Systems Design and Implementation (OSDI). pp. 209–224 (2008)
- [18] Cadar, C., Sen, K.: Symbolic Execution for Software Testing: Three Decades Later. *Communications of the ACM* **56**(2), 82–90 (Feb 2013)
- [19] Clarke, L.A.: A Program Testing System. In: ACM Annual Conference. pp. 488–491 (1976)
- [20] Coen-Portisini, A., Denaro, G., Ghezzi, C., Pezzè, M.: Using symbolic execution for verifying safety-critical systems. In: Proceedings of the Joint European Software Engineering Conference and ACM SIGSOFT Symposium on the Foundations of Software Engineering (ESEC/FSE 2001). pp. 142–151 (2001)
- [21] De Moura, L., Bjørner, N.: Z3: An Efficient SMT Solver. In: International Conference on Tools and Algorithms for Construction and Analysis of Systems (TACAS). pp. 337–340 (2008)
- [22] Deng, X., Lee, J., Robby: Bogor/Kiasan: A K-Bounded Symbolic Execution for Checking Strong Heap Properties of Open Systems. In: IEEE/ACM International Conference on Automated Software Engineering (ASE). pp. 157–166 (2006)
- [23] Deng, X., Lee, J., Robby: Efficient and formal generalized symbolic execution. *Automated Software Engineering* **19**, 233–301 (2012). <https://doi.org/10.1007/s10515-011-0089-9>
- [24] Deng, X., Robby, Hatcliff, J.: Towards a case-optimal symbolic execution algorithm for analyzing strong properties of object-oriented programs. In: 5th IEEE International Conference on Software Engineering and Formal Methods (SEFM 2007). pp. 273–282 (2007)
- [25] Deng, X., Robby, Hatcliff, J.: Towards a case-optimal symbolic execution algorithm for analyzing strong properties of object-oriented programs. In: Fifth IEEE International Conference on Software Engineering and Formal Methods (SEFM 2007). pp. 273–282 (2007). <https://doi.org/10.1109/SEFM.2007.43>
- [26] Do, H., Elbaum, S.G., Rothermel, G.: Supporting controlled experimentation with testing techniques: An infrastructure and its potential impact. *Empirical Software Engineering: An International Journal* **10**(4), 405–435 (2005)
- [27] Filieri, A., Pasareanu, C.S., Yang, G.: Quantification of software changes through probabilistic symbolic execution (n). In: 2015 30th IEEE/ACM International Conference on Automated Software Engineering (ASE). pp. 703–708 (2015). <https://doi.org/10.1109/ASE.2015.78>
- [28] Galeotti, J.P., Rosner, N., López Pombo, C.G., Frias, M.F.: Analysis of invariants for efficient bounded verification. In: Proceedings of the 19th International Symposium on Software Testing and Analysis. pp. 25–36. ISSTA '10, ACM, New York, NY, USA (2010). <https://doi.org/10.1145/1831708.1831712>, <http://doi.acm.org/10.1145/1831708.1831712>
- [29] Geldenhuys, J., Aguirre, N., Frias, M.F., Visser, W.: Bounded lazy initialization. In: NASA Formal Methods: 5th International Symposium, NFM 2013, Moffett Field, CA, USA, May 14–16, 2013. Proceedings 5, pp. 229–243. Springer (2013)
- [30] Godefroid, P., Klarlund, N., Sen, K.: DART: directed automated random testing. In: Proceedings of the ACM SIGPLAN 2005 Conference on Programming Language Design and Implementation (PLDI 2005). pp. 213–223 (2005)
- [31] Hansen, T., Schachte, P., Søndergaard, H.: State joining and splitting for the symbolic execution of binaries. In: Bensalem, S., Peled, D.A. (eds.) Runtime Verification. pp. 76–92. Springer Berlin Heidelberg, Berlin, Heidelberg (2009)
- [32] He, D., Deng, Z., Zhang, Y., Chan, S., Cheng, Y., Guizani, N.: Smart contract vulnerability analysis and security audit. *IEEE Network* **34**(5), 276–282 (2020). <https://doi.org/10.1109/MNET.001.1900656>
- [33] Khurshid, S., Păsăreanu, C.S., Visser, W.: Generalized symbolic execution for model checking and testing. In: Tools and Algorithms for Construction and Analysis of Systems. LNCS 2619, Springer (2003)
- [34] Khurshid, S., Păsăreanu, C.S., Visser, W.: Generalized symbolic execution for model checking and testing. In: Proceedings of the 9th International Conference on Tools and Algorithms for the Construction and Analysis of Systems. pp. 553–568. TACAS'03, Springer-Verlag, Berlin, Heidelberg (2003), <http://dl.acm.org/citation.cfm?id=1765871.1765924>
- [35] King, J.C.: Symbolic Execution and Program Testing. *Communications of the ACM* **19**(7), 385–394 (1976)
- [36] Koelbl, A., Pixley, C.: Constructing efficient formal models from high-level descriptions using symbolic simulation. *International Journal of Parallel Programming* **33**(6), 645–666 (Dec 2005). <https://doi.org/10.1007/s10766-005-8910-3>
- [37] Kuznetsov, V., Kinder, J., Bucur, S., Candea, G.: Efficient state merging in symbolic execution. In: Proceedings of the 33rd ACM SIGPLAN Conference on Programming Language Design and Implementation. p. 193–204. PLDI '12, Association for Computing Machinery, New York, NY, USA (2012). <https://doi.org/10.1145/2254064.2254088>, <https://doi.org/10.1145/2254064.2254088>
- [38] Li, G., Ghosh, I., Rajan, S.: KLOVER: A Symbolic Execution and Automatic Test Generation Tool for C++ Programs. In: International Conference on Computer Aided Verification (CAV). pp. 53–68 (2011)
- [39] Li, L., Lu, Y., Xue, J.: Dynamic symbolic execution for polymorphism. In: Proceedings of the 26th International Conference on Compiler Construction. p. 120–130. CC 2017, Association for Computing Machinery, New York, NY, USA (2017). <https://doi.org/10.1145/3033019.3033029>, <https://doi.org/10.1145/3033019.3033029>
- [40] Luckow, K., Kersten, R., Păsăreanu, C.: Symbolic Complexity Analysis Using Context-Preserving Histories. In: IEEE International Conference on Software Testing, Verification and Validation (ICST). pp. 58–68 (Mar 2017)
- [41] Pasareanu, C.S., Visser, W.: A survey of new trends in symbolic execution for software testing and analysis. *International Journal on Software Tools for Technology Transf.* **11**(4), 339–353 (Oct 2009). <https://doi.org/10.1007/s10009-009-0118-1>, <http://dx.doi.org/10.1007/s10009-009-0118-1>
- [42] Păsăreanu, C.S., Rungta, N., Visser, W.: Symbolic execution with mixed concrete-symbolic solving. In: International Symposium on Software Testing and Analysis (2011)
- [43] Rosner, N., Geldenhuys, J., Aguirre, N.M., Visser, W., Frias, M.F.: Bliss: improved symbolic execution by bounded lazy initialization with sat support. *IEEE Transactions on Software Engineering* **41**(7), 639–660 (2015)
- [44] Sen, K., Marinov, D., Agha, G.: CUTE: a concolic unit testing engine for C. In: Proceedings of the 10th European software engineering conference held jointly with 13th ACM SIGSOFT international symposium on Foundations of software engineering (ESEC/FSE-13). pp. 263–272 (2005)

- [45] Siddiqui, J.H., Khurshid, S.: Staged symbolic execution. In: ACM Symposium on Applied Computing (2012). <https://doi.org/10.1145/2231936.2231988>
- [46] Sinha, N.: Symbolic program analysis using term rewriting and generalization. In: International Conference on Formal Methods in Computer-Aided Design. pp. 19:1–19:9. IEEE (2008)
- [47] Staats, M., Păsăreanu, C.S.: Parallel symbolic execution for structural test generation. In: Proceedings of the 19th International Symposium on Software Testing and Analysis (ISSTA 2010). pp. 183–194. ACM (2010). <https://doi.org/10.1145/1831708.1831732>
- [48] Stephens, N., Grosen, J., Salls, C., Dutcher, A., Wang, R., Corbetta, J., Shoshitaishvili, Y., Kruegel, C., Vigna, G.: Driller: Augmenting fuzzing through selective symbolic execution. In: NDSS. vol. 16, pp. 1–16 (2016)
- [49] Tillmann, N., de Halleux, J.: Pex: White Box Test Generation for .NET. In: International Conference on Tests and Proofs (TAP). pp. 134–153 (2008)
- [50] Visser, W., Geldenhuys, J., Dwyer, M.B.: Green: Reducing, reusing and recycling constraints in program analysis. In: Proceedings of the ACM SIGSOFT International Symposium on Foundations of Software Engineering. pp. 1–11. FSE '12, ACM (2012)
- [51] Visser, W., Păsăreanu, C.S., Khurshid, S.: Test input generation with Java PathFinder. In: Proceedings of the 2004 ACM SIGSOFT International Symposium on Software Testing and Analysis (ISSTA 2004). pp. 97–107. ACM (2004)
- [52] Vivanti, M., Mis, A., Gorla, A., Fraser, G.: Search-Based Data-Flow Test Generation. In: IEEE International Symposium on Software Reliability Engineering (ISSRE). pp. 370–379 (2013)
- [53] Wang, T., Wei, T., Gu, G., Zou, W.: Checksum-aware fuzzing combined with dynamic taint analysis and symbolic execution. ACM Trans. Inf. Syst. Secur. **14**(2) (sep 2011). <https://doi.org/10.1145/2019599.2019600>, <https://doi.org/10.1145/2019599.2019600>
- [54] Yang, G., Păsăreanu, C.S., Khurshid, S.: Memoized symbolic execution. In: Proceedings of the 2012 International Symposium on Software Testing and Analysis. pp. 144–154 (2012)
- [55] Yang, G., Person, S., Rungta, N., Khurshid, S.: Directed incremental symbolic execution. ACM Trans. Softw. Eng. Methodol. **24**(1) (oct 2014). <https://doi.org/10.1145/2629536>, <https://doi.org/10.1145/2629536>
- [56] Zheng, P., Zheng, Z., Luo, X.: Park: Accelerating smart contract vulnerability detection via parallel-fork symbolic execution. In: Proceedings of the 31st ACM SIGSOFT International Symposium on Software Testing and Analysis. pp. 740–751 (2022)

A FULL OPERATIONAL SEMANTICS FOR POSE

In this Appendix we introduce an example imperative, object-oriented programming language and give operational semantics for path-optimal symbolic execution. Figure 6 reports the syntax of the language. A program is a sequence of class declarations followed by an expression to be evaluated. Classes have exactly one superclass (there is no multiple inheritance nor interfaces) and multiple fields and methods. The body of a method is a single expression.

There are many types of expressions, but here we want focus on expressions that read the content of object fields (getfield expressions $e.f$), modify the content of object fields (putfield expressions $e.f := e$), conditional expressions $\text{if } e \ e \ e$, and method invocation expressions $e.m(\bar{e})$. These are the expressions whose semantics is more affected by the fact that their subexpressions may be symbolic.

Figure 7 reports the syntax of the configurations and the evaluation contexts used in the operational semantics definition. The small-step operational semantics transition relation \Rightarrow is defined in Figure 8 as a suitable composition of two distinct transition relations, the *computation* transition relation \rightarrow , and the (reflexive-transitive closure of the) *refinement* transition relation \rightsquigarrow . These relations are formally defined in Figure 9 and Figure 10 respectively. The computation transition accounts for the steps that implement a computational step performed to progress the evaluation of the current expression in the program. The refinement transition adds information to the current configuration that is already implicit in it, without progressing the evaluation of the program. The added

information may come in the shape of a heap object, or of a value in a field of an object.

In POSE each symbolic reference points to a *symbolic object* in the initial heap. In the beginning of symbolic execution these objects do not actually exist in the initial heap, and are materialized on demand (through a suitable refinement step) when the corresponding symbolic reference is used to access the object. This is the only similarity of POSE with generalized symbolic execution. Differently from the latter, where an input reference is initialized to point to the object it may alias to, in POSE every symbolic reference points to a distinct symbolic object, and the alternative effects of the alias relationship are encoded *inside each object*, by means of if-then-else-values (ite-values, with shape $\text{ite}(\dots)$).

Let us consider the computation semantics of getfield expressions $e.f$, that read the content of field f from a heap object denoted by expression e . Rule Getfield (c5) considers the case where e evaluates to the location l of a *concrete object*, i.e., of an object created after the start of symbolic execution by means of a new expression. In this case, the value is simply read from the object field. Rule Getfield (c1) considers the case where e evaluates to a symbol Y with reference type. The rule may fire only if a symbolic object for Y exists in the heap ($Y \in \text{dom}(H)$), the field f is present in the symbolic object ($f \in \text{dom}(H(Y))$), and the slot corresponding to the field f has been initialized with some value ($H(Y)(f) \neq \perp$). We will discuss all these conditions when explaining the refinement transitions. When all the conditions are met, the value is read from the object field, exactly as for concrete objects. Finally, rules Getfield (c2)-(c4) cope with $\text{ite}(\sigma, \sigma_1, \sigma_2)$ symbolic references. These symbolic references may emerge as expressions of alias conditions and are handled by reading the field f from the objects denoted by the expressions σ_1 and σ_2 , and returning the ite-expression combining the results (rule Getfield (c2)). The resulting path condition is obtained by suitably merging the path conditions obtained by evaluating $\sigma_1.f$ and $\sigma_2.f$, by means of the function $\Sigma' = \text{mergePC}(\sigma, \Sigma'_1, \Sigma'_2)$ defined as follows: If $\Sigma'_1 = \sigma_{11}, \dots, \sigma_{1m}$ and $\Sigma'_2 = \sigma_{21}, \dots, \sigma_{2w}$, then $\Sigma' = (\sigma \Rightarrow \sigma_{11}), \dots, (\sigma \Rightarrow \sigma_{1m}), (\neg\sigma \Rightarrow \sigma_{21}), \dots, (\neg\sigma \Rightarrow \sigma_{2w})$. Similarly, the resulting heap is obtained by merging the updates that the evaluations of $\sigma_1.f$ and $\sigma_2.f$ apply to the heap, by means of the function $H' = \text{mergeHGf}(H'_1, H'_2, f)$ defined as follows:

- (1) if $H'_1(u) = H'_2(u)$ then $H'(u) = H'_1(u) = H'_2(u)$;
- (2) if $H'_1(u) \neq H'_2(u)$, then u is a symbolic reference input (that we indicate with Y), $H'_1(Y) = H'_2(Y)[f \mapsto Z]$, $H'_2(Y) = H'_1(Y)[f \mapsto \perp]$ or $H'_1(Y) = H'_2(Y)[f \mapsto \perp]$, $H'_2(Y) = H'_1(Y)[f \mapsto Z]$ for some Z : in this case it is $H'(Y) = H'_1(Y)[f \mapsto Z] = H'_2(Y)[f \mapsto Z]$;
- (3) if $u \notin \text{dom}(H'_2)$ and $H'_1(u)(f) = Z$, then u is a symbolic reference input (that we indicate with Y), and $H'(Y) = H'_1(Y)$;
- (4) if $u \notin \text{dom}(H'_1)$ and $H'_2(u)(f) = Z$, then u is a symbolic reference input (that we indicate with Y), and $H'(Y) = H'_2(Y)$.

In the case one of the field access expression $\sigma_1.f$, $\sigma_2.f$ cannot evaluate, the ite-based getfield reduces to the other field access expression (rules Getfield (c3) and (c4)).

Now we analyze the refinement semantics of getfield expressions. Rule Getfield (r1) handles the situation where a symbolic reference has no corresponding symbolic object in the heap yet—i.e., is *unbound*. For the sake of simplicity we suppose that each

Programs	P	$::= \bar{C} e$
Classes	C	$::= \text{class } c : c \{ \overline{t f}; \bar{D} \}$
Methods	D	$::= t m(\overline{t x}) := e$
Program expressions	e	$::= x v \text{new } c e.f e.f := e \text{let } x := e \text{ in } e e \text{ op } e \text{op } e \text{if } e \text{ e } e e.m(\bar{e})$
Types	t	$::= c \text{bool} \text{int}$
Values	v	$::= p u$
Primitive values	p	$::= r X$
Reference values	u	$::= \text{null} l Y$
Literals	r	$::= b n$
Booleans	b	$::= \text{true} \text{false}$
Integers	n	$::= \dots - 1 0 1 \dots$
Operators	op	$::= + = \dots$
Locations	l	
Identifiers	c, f, m, x, X, Y	

Figure 6: Language syntax

Configurations	J	$::= H \Sigma \eta$
Configuration expressions	η	$::= x \sigma \text{new } c \eta.f \eta.f := \eta \text{let } x := \eta \text{ in } \eta \eta \text{ op } \eta \text{op } \eta \text{if } \eta \eta \eta \eta.m(\bar{\eta})$
Heaps	H	$::= \bar{u} \mapsto \bar{o}, u \neq \text{null}$
Objects	o	$::= (\bar{f} \mapsto \sigma)^c (\bar{f} \mapsto \sigma)$
Path conditions	Σ	$::= \emptyset \Sigma, \sigma$
Symbolic values	σ	$::= \perp v \sigma \text{ op } \sigma \text{op } \sigma Y \leq: c Y.f = Z \text{ite}(Y = Y, \sigma, \sigma)$
Evaluation contexts	E	$::= - E.f E.f := \eta \sigma.f := E \text{let } x := E \text{ in } \eta E \text{ op } \eta \sigma \text{ op } E \text{op } E \text{if } E \eta \eta E.m(\bar{\eta})$ $ \sigma.m(\bar{\sigma}, E, \bar{\eta})$

Figure 7: Syntax of configurations and evaluation contexts

$$\text{Step: } \frac{H \Sigma \eta \rightsquigarrow^* H' \Sigma' \eta \quad H' \Sigma' \eta \rightarrow H'' \Sigma'' \eta''}{H \Sigma \eta \Rightarrow H'' \Sigma'' \eta''}$$

Figure 8: Small-step operational semantics

field f is contained in exactly one class. If $c = \text{class}(f)$ is the class that contains the field f , then the refinement step adds a symbolic object of class c to the heap, whose fields are all uninitialized (the function $\text{fields}(c)$ yields the set of all the fields declared in c and in its superclasses), binds Y to the new object, and updates the path condition to reflect the fact that field access has success ($\neg Y = \text{null}$) and that the symbolic object's type is a subclass of c ($Y \leq: c$). Rule Getfield (r1.b) handles the situation where Y has an associated symbolic object in the heap, but this does not contain the field f . If we assume the programs to be type-correct, this situation may only arise if the symbolic object was previously created with the help of a superclass of c . Note that, upon creation, a symbolic object is assumed to possibly be of *any subclass* of its creation class. If later during symbolic execution a finer type assumption must be

performed, as in this case, the missing fields are added to the object, with all the new slots left uninitialized. Also, the path condition is updated to reflect the new type assumption on the symbolic object bound to Y ($Y \leq: c$). Finally, the rule Getfield (r2) handles the situation where the field f in the symbolic object pointed by Y is uninitialized ($H(Y)(f) = \perp$). The refinement rule therefore initializes the field with a special value $\text{assume}(H, Y, f, Z)$ that accounts for all the possible alias relations between the symbolic reference Y and all the other symbolic references that are bound. Formally the function $\text{assume}(H, Y, f, Z)$ is defined as follows:

$$\text{assume}(H, Y, f, Z) = \text{ite}(Y = Y_1, H(Y_1)(f), \dots, \text{ite}(Y = Y_m, H(Y_m)(f), Z) \dots)$$

$$\begin{array}{c}
\text{New: } \frac{\text{fields}(c) = \bar{f} \quad l \notin \text{dom}(H)}{H \Sigma \text{ new } c \rightarrow H, l \mapsto (\bar{f} \mapsto \text{default})^c \Sigma l} \quad \text{Getfield (c1): } \frac{Y \in \text{dom}(H) \quad f \in \text{dom}(H(Y)) \quad H(Y)(f) \neq \perp}{H \Sigma Y.f \rightarrow H \Sigma H(Y)(f)} \\
\text{Getfield (c2): } \frac{H \Sigma \sigma_1.f \Rightarrow H'_1 \Sigma'_1 \sigma'_1 \quad H \Sigma \sigma_2.f \Rightarrow H'_2 \Sigma'_2 \sigma'_2 \quad H' = \text{mergeHGf}(H'_1, H'_2, f) \quad \Sigma' = \text{mergePC}(\sigma, \Sigma'_1, \Sigma'_2)}{H \Sigma \text{ ite}(\sigma, \sigma_1, \sigma_2).f \rightarrow H' \Sigma' \text{ ite}(\sigma, \sigma'_1, \sigma'_2)} \\
\text{Getfield (c3): } \frac{H \Sigma \sigma_1.f \Rightarrow H' \Sigma' \sigma'_1 \quad H \Sigma \sigma_2.f \Rightarrow}{H \Sigma \text{ ite}(\sigma, \sigma_1, \sigma_2).f \rightarrow H' \Sigma', \sigma \sigma'_1} \\
\text{Getfield (c4): } \frac{H \Sigma \sigma_1.f \Rightarrow \quad H \Sigma \sigma_2.f \Rightarrow H' \Sigma' \sigma'_2}{H \Sigma \text{ ite}(\sigma, \sigma_1, \sigma_2).f \rightarrow H' \Sigma', \neg \sigma \sigma'_2} \quad \text{Getfield (c5): } \frac{}{H \Sigma l.f \rightarrow H \Sigma H(l)(f)} \\
\text{Putfield (c1): } \frac{Y \in \text{dom}(H) \quad f \in \text{dom}(H(Y)) \quad H_r = \text{update}(H, Y, f, \sigma')}{H \Sigma Y.f := \sigma' \rightarrow H_r[Y \mapsto H(Y)[f \mapsto \sigma']] \Sigma \sigma'} \\
\text{Putfield (c2): } \frac{H \Sigma \sigma_1.f := \sigma' \Rightarrow H'_1 \Sigma'_1 \sigma' \quad H \Sigma \sigma_2.f := \sigma' \Rightarrow H'_2 \Sigma'_2 \sigma' \quad H' = \text{mergeHPf}(H'_1, H'_2, H, f, \sigma, \Sigma'_1, \Sigma'_2) \quad \Sigma' = \text{mergePC}(\sigma, \Sigma'_1, \Sigma'_2), \text{mergeClauses}(H'_1, H'_2, H, f, \sigma, \Sigma'_1, \Sigma'_2)}{H \Sigma \text{ ite}(\sigma, \sigma_1, \sigma_2).f := \sigma' \rightarrow H' \Sigma' \sigma'} \\
\text{Putfield (c3): } \frac{H \Sigma \sigma_1.f := \sigma' \Rightarrow H' \Sigma' \sigma' \quad H \Sigma \sigma_2.f := \sigma' \Rightarrow}{H \Sigma \text{ ite}(\sigma, \sigma_1, \sigma_2).f := \sigma' \rightarrow H' \Sigma', \sigma \sigma'} \quad \text{Putfield (c4): } \frac{H \Sigma \sigma_1.f := \sigma' \Rightarrow \quad H \Sigma \sigma_2.f := \sigma' \Rightarrow H' \Sigma' \sigma'}{H \Sigma \text{ ite}(\sigma, \sigma_1, \sigma_2).f := \sigma' \rightarrow H' \Sigma', \neg \sigma \sigma'} \\
\text{Putfield (c5): } \frac{}{H \Sigma l.f := \sigma' \rightarrow H[l \mapsto H(l)[f \mapsto \sigma']] \Sigma \sigma'} \\
\text{Let: } \frac{}{H \Sigma \text{ let } x := \sigma \text{ in } e \rightarrow H \Sigma e[\sigma/x]} \quad \text{Op (c1): } \frac{r_1 \text{ op } r_2 = r}{H \Sigma r_1 \text{ op } r_2 \rightarrow H \Sigma r} \quad \text{Op (c2): } \frac{\text{op } r_1 = r}{H \Sigma \text{ op } r_1 \rightarrow H \Sigma r} \\
\text{Eq (c1): } \frac{}{H \Sigma v = v \rightarrow H \Sigma \text{ true}} \quad \text{Eq (c2): } \frac{r_1 \neq r_2}{H \Sigma r_1 = r_2 \rightarrow H \Sigma \text{ false}} \quad \text{Eq (c3): } \frac{l_1 \neq l_2}{H \Sigma l_1 = l_2 \rightarrow H \Sigma \text{ false}} \\
\text{Eq (c4): } \frac{}{H \Sigma l = \text{null} \rightarrow H \Sigma \text{ false}} \quad \text{Eq (c5): } \frac{}{H \Sigma \text{ null} = l \rightarrow H \Sigma \text{ false}} \quad \text{Eq (c6): } \frac{}{H \Sigma Y = l \rightarrow H \Sigma \text{ false}} \\
\text{Eq (c7): } \frac{}{H \Sigma l = Y \rightarrow H \Sigma \text{ false}} \quad \text{If (c1): } \frac{}{H \Sigma \text{ if true } e_1 e_2 \rightarrow H \Sigma e_1} \\
\text{If (c2): } \frac{}{H \Sigma \text{ if false } e_1 e_2 \rightarrow H \Sigma e_2} \quad \text{If (c3): } \frac{}{H \Sigma \text{ if } \sigma e_1 e_2 \rightarrow H \Sigma, \sigma e_1} \quad \text{If (c4): } \frac{}{H \Sigma \text{ if } \sigma e_1 e_2 \rightarrow H \Sigma, \neg \sigma e_2} \\
\text{Invoke (c1): } \frac{H(l) = o^c \quad \text{recv}(c, m) = c' \quad \text{method}(c', m) = t m (\bar{t} x) \{e_m\}}{H \Sigma l.m(\bar{\sigma}) \rightarrow H \Sigma e_m[l/\text{this}][\bar{\sigma}/x]} \\
\text{Invoke (c2): } \frac{\text{method}(c', m) = t m (\bar{t} x) \{e_m\} \quad O = \{c \mid \text{overrides}(c, m, c')\}}{H \Sigma Y.m(\bar{\sigma}) \rightarrow H \Sigma, \neg Y = \text{null}, Y \leq: c', \neg Y \leq: \bar{c}_{c \in O} e_m[l/\text{this}][\bar{\sigma}/x]} \quad \text{Invoke (c3): } \frac{H \Sigma \sigma_1.m(\bar{\sigma}) \rightarrow H \Sigma'_1 \eta'_1}{H \Sigma \text{ ite}(\sigma, \sigma_1, \sigma_2).m(\bar{\sigma}) \rightarrow H \Sigma'_1, \sigma \eta'_1} \\
\text{Invoke (c4): } \frac{H \Sigma \sigma_2.m(\bar{\sigma}) \rightarrow H \Sigma'_2 \eta'_2}{H \Sigma \text{ ite}(\sigma, \sigma_1, \sigma_2).m(\bar{\sigma}) \rightarrow H \Sigma'_2, \neg \sigma \eta'_2} \quad \text{Ctx (c): } \frac{H \Sigma \eta \rightarrow H' \Sigma' \eta'}{H \Sigma E[\eta/-] \rightarrow H' \Sigma' E[\eta'/-]}
\end{array}$$

Figure 9: Small-step operational semantics, computation transition

$$\begin{array}{c}
\text{Getfield (r1):} \frac{Y \notin \text{dom}(H) \quad \text{fields}(\text{class}(f)) = \overline{f'}}{H \Sigma Y.f \rightsquigarrow H, Y \mapsto (\overline{f'} \mapsto \perp) \Sigma, \neg Y = \text{null}, Y \leq: c Y.f} \\
\\
\text{Getfield (r1.b):} \frac{Y \in \text{dom}(H) \quad f \notin \text{dom}(H(Y)) \quad \text{fields}(\text{class}(f)) \setminus \text{fields}(H(Y)) = \overline{f'}}{H \Sigma Y.f \rightsquigarrow H[Y \mapsto (H(Y), \overline{f'} \mapsto \perp)] \Sigma, Y \leq: c Y.f} \\
\\
\text{Getfield (r2):} \frac{Y \in \text{dom}(H) \quad f \in \text{dom}(H(Y)) \quad H(Y)(f) = \perp \quad Z \text{ fresh}}{H \Sigma Y.f \rightsquigarrow H[Y \mapsto H(Y)[f \mapsto \text{assume}(H, Y, f, Z)]] \Sigma, Y.f = Z Y.f} \\
\\
\text{Putfield (r1):} \frac{Y \notin \text{dom}(H) \quad \text{fields}(\text{class}(f)) = \overline{f'}}{H \Sigma Y.f := \sigma' \rightsquigarrow H, Y \mapsto (\overline{f'} \mapsto \perp) \Sigma, \neg Y = \text{null}, Y \leq: c Y.f := \sigma'} \\
\\
\text{Putfield (r1.b):} \frac{Y \in \text{dom}(H) \quad f \notin \text{dom}(H(Y)) \quad \text{fields}(\text{class}(f)) \setminus \text{fields}(H(Y)) = \overline{f'}}{H \Sigma Y.f := \sigma' \rightsquigarrow H[Y \mapsto (H(Y), \overline{f'} \mapsto \perp)] \Sigma, Y \leq: c Y.f := \sigma'} \\
\\
\text{Ctx (r):} \frac{H \Sigma \eta \rightsquigarrow H' \Sigma' \eta'}{H \Sigma E[\eta/-] \rightsquigarrow H' \Sigma' E[\eta'/-]}
\end{array}$$

Figure 10: Small-step operational semantics, refinement transition

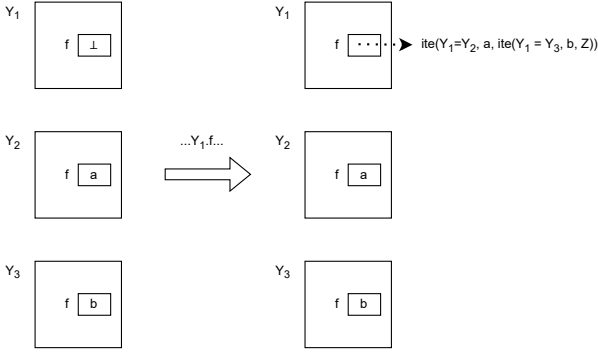

Figure 11: Example semantics of field reading expressions

where $\{Y_1 \dots Y_m\} = \{Y' \in \text{dom}(H) \mid Y' \neq Y \wedge f \in \text{dom}(H(Y')) \wedge H(Y')(f) \neq \perp\}$. The set $\{Y_1 \dots Y_m\}$ is the *alias set* of Y , and is composed by the set of all the bound symbolic references that point to a type-compatible object with c , and whose f field is initialized. The symbolic value Z stands for the initial value of $Y.f$, the value that would have the field $Y.f$ if symbolic execution up to the current instant of time did not modify the field. The *assume* value that is assigned to the $Y.f$ field reflects the possible current value of the field: For all Y_i , If Y aliases Y_i , then $Y.f$ has the value stored in $Y_i.f$. If Y does not alias any object in its alias set, then it still contains the unmodified initial value Z .

Figure 11 reports an example illustrating the effect of the evaluation of a field reading expression. Let us suppose that the field $Y_1.f$ is uninitialized, that the expression $Y_1.f$ must be evaluated, and that two symbolic references Y_2 and Y_3 are bound in the heap with a value for field f . The effect of refinement is to initialize field $Y_1.f$ to the *ite* value shown in figure, which takes into account the

possible alias relations of Y_1 with Y_2 and Y_3 . This value is returned as a result of the evaluation of the expression.

The computation semantics of field assignment expressions, $e.f := e$, can be described as follows. Rule Putfield (c5) is for concrete objects: If l is the location of a concrete object, the field f of the object is directly updated. More complex is the effect of updating a field of a symbolic object, as described by rule Putfield (c1). The update can be performed only if Y is bound and the symbolic object has field f : Otherwise, refinement is necessary: The corresponding refinement transitions, Putfield (r1) and Putfield (r1.b), are almost identical to Getfield (r1) and Getfield (r1.b), and will not be discussed. The effect of a field update does not only affect the symbolic object bound to Y : It affects all the symbolic objects in the alias set of Y . Formally the impact of the update on the alias set is described by the definition of $H_r = \text{update}(H, Y, f, \sigma')$:

$$\begin{aligned}
\text{dom}(H_r) &= \text{dom}(H) \wedge \forall u' \in \text{dom}(H), f' \in \text{dom}(H)(Y') \mid \\
&u' = Y' \wedge Y' \neq Y \wedge f' = f \wedge H(Y')(f) \neq \perp \\
&\implies H_r(u')(f') = \text{ite}(Y = Y', \sigma', H(u')(f')) \wedge \\
&\neg(u' = Y' \wedge Y' \neq Y \wedge f' = f \wedge H(Y')(f) \neq \perp) \\
&\implies H_r(u')(f') = H(u')(f').
\end{aligned}$$

In plain terms, if Y' is a bound symbolic reference to a type-compatible object, whose f field is initialized, the field $Y'.f$ must also be updated to an *ite* reflecting the potential alias relation: If Y aliases Y' , then $Y'.f$ also assumes the value assigned to $Y.f$, otherwise it retains its current value. Finally, rules Putfield (c2)-(c4) handle the case where an *ite*($\sigma, \sigma_1, \sigma_2$) symbolic reference is used to refer the object to be updated. Rules Putfield (c3) and (c4) are analogous to Getfield (c3) and (c4), and will not be discussed. Rule Putfield (c2) defines the effects of a field update on the heap and the path condition in terms of a suitable merging between the effects of updating the

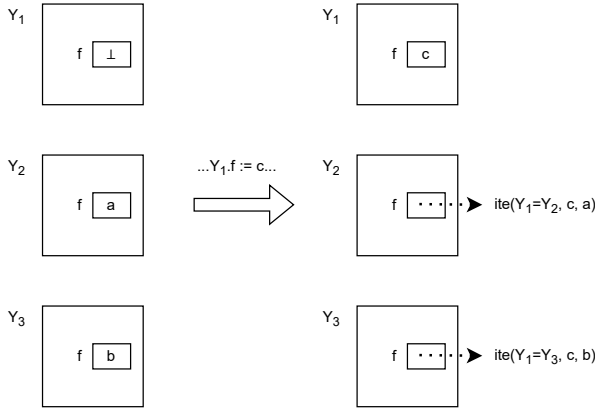

Figure 12: Example semantics of field assignment expressions

objects referred by σ_1 and σ_2 respectively. The formal definitions of the *mergeHPf* and *mergeClauses* functions are as follows. It is $H' = \text{mergeHPf}(H'_1, H'_2, H, f, \sigma, \Sigma'_1, \Sigma'_2)$ iff $\text{dom}(H) \subseteq \text{dom}(H'_1)$, $\text{dom}(H) \subseteq \text{dom}(H'_2)$, $\text{dom}(H') = \text{dom}(H'_1) \cup \text{dom}(H'_2)$, and for all $u \in \text{dom}(H')$ it is:

- (1) if $H'_1(u) = H'_2(u)$ then $H'(u) = H'_1(u) = H'_2(u)$;
- (2) if $H'_1(u) \neq H'_2(u)$ and $H'_1(u) = H'_2(u)[f \mapsto \sigma_1]$, $H'_2(u) = H'_1(u)[f \mapsto \sigma_2]$, for some σ_1, σ_2 , then it is $H'(u) = H'_1(u)[f \mapsto \text{ite}(\sigma, \sigma_1, \sigma_2)]$;
- (3) if $H'_1(u) \neq H'_2(u)$ and $H'_1(u) = H'_2(u)[f \mapsto \sigma_1]$, $H'_2(u) = H'_1(u)[f \mapsto \perp]$, for some σ_1 , then u is a symbolic reference input (that we indicate with Y), $H'(Y) = H'_1(Y)[f \mapsto \text{ite}(\sigma, \sigma_1, Z)]$, where Z is a fresh symbol if in Σ'_1 there is not a clause $Y.f = Z'$, otherwise $Z = Z'$;
- (4) if $H'_1(u) \neq H'_2(u)$ and $H'_1(u) = H'_2(u)[f \mapsto \perp]$, $H'_2(u) = H'_1(u)[f \mapsto \sigma_2]$, for some σ_2 , then u is a symbolic reference input (that we indicate with Y), $H'(Y) = H'_2(Y)[f \mapsto \text{ite}(\sigma, Z, \sigma_2)]$, where Z is a fresh symbol if in Σ'_2 there is not a clause $Y.f = Z'$, otherwise $Z = Z'$;
- (5) if $u \notin \text{dom}(H'_2)$ and $H'_1(u)(f) = \sigma_1$, then u is a symbolic reference input (that we indicate with Y), $H'(Y) = H'_1(Y)[f \mapsto \text{ite}(\sigma, \sigma_1, Z)]$, where Z is a fresh symbol if in Σ'_1 there is not a clause $Y.f = Z'$, otherwise $Z = Z'$;
- (6) if $u \notin \text{dom}(H'_1)$ and $H'_2(u)(f) = \sigma_2$, then u is a symbolic reference input (that we indicate with Y), $H'(Y) = H'_2(Y)[f \mapsto \text{ite}(\sigma, Z, \sigma_2)]$, where Z is a fresh symbol if in Σ'_2 there is not a clause $Y.f = Z'$, otherwise $Z = Z'$.

The function *mergeClauses*($H'_1, H'_2, H, f, \sigma, \Sigma'_1, \Sigma'_2$) yields the set of all the clauses $Y.f = Z$, where Z are all (and only) the fresh symbols introduced at points 3) and 4) in the definition of *merge*, and Y is the symbolic input reference that points to the symbolic object where Z has been injected.

Figure 12 reports an example of the effect of the evaluation of a field assignment expression. We again suppose that three symbolic references, Y_1, Y_2, Y_3 , are bound to symbolic objects, that all the symbolic objects define the field f , that the object Y_2 and Y_3 have field f initialized, and that the expression $Y_1.f := c$ must be evaluated. In this situation no refinement transition fires: The computation transition updates the field f of Y_1 to the c value, and as a

further effect updates the fields f of all the other symbolic objects with *ite* terms that reflect the possible effect of the update on these objects in case an alias relation subsists.

Conditional expressions *if e e e* have associated only computation transitions. Rules *If (c1)* and *If (c2)* manage the cases *if true ...* and *if false ...*, that reduce to the evaluation of the corresponding branch. Rules *If (c3)* and *If (c4)* manage the case where the condition of the *if* expression is symbolic. In this case both transitions may fire, and the path condition is updated to reflect the assumption associated to the branch taken.

Finally, method invocation expressions $e.m(\bar{e})$ are handled only by computation transitions. We introduce the following definitions:

- The function *recv*(c, m) yields the class that provides the implementation of method m to class c (it is c itself iff c implements m , or an ancestor of c iff c inherits the implementation of m).
- The predicate *impl*(c, m) is true iff c implements m .
- The predicate *sees*(c, m, c') is true iff c is a subclass of c' , c' implements the method m , and no superclass of c and subclass of c' implements m (note that c may implement m).
- The predicate *overrides*(c, m, c') is defined as $c \neq c' \wedge \text{sees}(c, m, c') \wedge \text{impl}(c, m)$.

We can deduce that *recv*(c, m) = c' , for $c \neq c'$, iff *sees*(c, m, c') \wedge $\neg \text{impl}(c, m)$, and that *recv*(c, m) = c iff *impl*(c, m). Given the above definitions it is easy to see that rule *Invoke (c1)* (method invocation on concrete objects) finds the implementation of the method of the object pointed by location l , and invokes it. Different is the case (rule *Invoke (c2)*) where the receiver of the method invocation is a symbolic reference. In this case, since the symbolic reference might refer to an object of any class that declares the method m , symbolic execution branches to all possible implementations of m . The path condition at each branch is assumed to reflect the assumption on the class of the symbolic receiver object: When the method m is executed, if m is declared by class c' , the object may have any subclass of c' that does not override m . The final rules *Invoke (c3)* and *Invoke (c4)* handle the case where the reference to the receiver object is an *ite*($\sigma, \sigma_1, \sigma_2$) symbolic reference. In synthesis, when such a reference is encountered, symbolic execution branches.

We conclude this Appendix by briefly discussing the remaining rules. The *Let* computation rule has the effect of performing a term substitution in its main argument. The *Op (c1)* and *Op (c2)* computation rules yield the result of the application of a binary or unary operator to concrete operands. The *Eq (c1)-(c7)* computation rules account for the semantics of equality, where syntactically identical values are always considered equal, distinct concrete locations are always considered different each other and from *null*, and symbolic references are always considered different from concrete locations. Finally, the context rules *Ctx (c)* and *Ctx (r)* extend the reduction semantics of expressions under the admissible evaluation contexts.