

Polynomial Pass Semi-Streaming Lower Bounds for K-Cores and Degeneracy

Sepehr Assadi* Prantar Ghosh† Bruno Loff‡ Parth Mittal§
Sagnik Mukhopadhyay¶

Abstract

The following question arises naturally in the study of graph streaming algorithms:

Is there any graph problem which is “not too hard”, in that it can be solved efficiently with total communication (nearly) linear in the number n of vertices, and for which, nonetheless, any streaming algorithm with $\tilde{O}(n)$ space (i.e., a semi-streaming algorithm) needs a polynomial $n^{\Omega(1)}$ number of passes?

Assadi, Chen, and Khanna [STOC 2019] were the first to prove that this is indeed the case. However, the lower bounds that they obtained are for rather non-standard graph problems.

Our first main contribution is to present the first polynomial-pass lower bounds for natural “not too hard” graph problems studied previously in the streaming model: **k -cores** and **degeneracy**. We devise a novel communication protocol for both problems with near-linear communication, thus showing that k -cores and degeneracy are natural examples of “not too hard” problems. Indeed, previous work have developed single-pass semi-streaming algorithms for approximating these problems. In contrast, we prove that any semi-streaming algorithm for *exactly* solving these problems requires (almost) $\Omega(n^{1/3})$ passes.

The lower bound follows by a reduction from a generalization of the **hidden pointer chasing (HPC)** problem of Assadi, Chen, and Khanna, which is also the basis of their earlier semi-streaming lower bounds.

Our second main contribution is improved **round-communication** lower bounds for the underlying communication problems at the basis of these reductions:

- We improve the previous lower bound of Assadi, Chen, and Khanna for HPC to achieve optimal bounds for this problem.
- We further observe that all current reductions from HPC can also work with a generalized version of this problem that we call **MultiHPC**, and prove an even stronger and optimal lower bound for this generalization.

These two results collectively allow us to improve the resulting pass lower bounds for semi-streaming algorithms by a polynomial factor, namely, from $n^{1/5}$ to $n^{1/3}$ passes.

*(sepehr@assadi.info) Cheriton School of Computer Science, University of Waterloo, Canada, and Department of Computer Science, Rutgers University, USA.

†(prantar.ghosh@gmail.com) Department of Computer Science, Georgetown University, USA. Part of this work was done while the author was at DIMACS, Rutgers University, USA

‡(bruno.loff@gmail.com) Department of Mathematics and LASIGE, Faculdade de Ciências, Universidade de Lisboa, Portugal.

§(parth.mittal@uwaterloo.ca) University of Waterloo, Canada.

¶(schwagznikst@gmail.com) University of Sheffield, UK.

Contents

1	Introduction	1
1.1	Polynomial Pass Lower Bounds in Graph Streams	1
1.2	k -Cores and Degeneracy in Graph Streams	3
1.3	Our Results	3
2	Overview	5
2.1	Hidden Pointer Chasing	5
2.2	Reduction to Degeneracy	7
2.3	Communication Upper Bounds for Degeneracy	9
3	Preliminaries	10
3.1	The Set-Intersection Problem	10
3.2	The (Boolean) Hidden Pointer Chasing Problem	10
3.3	The (Boolean) Multilayer Hidden Pointer Chasing Problem	11
3.4	Misaligned r -Round Protocols	12
3.5	Notation and Terminology	12
3.6	Positive Triangular Discrimination	13
3.7	Degeneracy and k -Cores	13
4	New Lower Bounds for HPC and Multilayer HPC	14
4.1	“Almost Solving”	15
4.2	Hard Distributions	16
4.3	Short Protocols for BMHPC Give Low-Information ε -Solvers for Set-Int	17
4.4	ε -Solvers for Set-Int Give Exact Solvers	21
4.4.1	A single round of π	22
4.4.2	The actual protocol	24
4.5	Short Protocols for BHPC Give Low-Information ε -Solvers for Set-Int	26
4.6	Putting it All Together	30
5	Reduction From BMHPC to Degeneracy	31
5.1	Construction of the Gadget Graph	32
5.2	The Analysis	34
5.3	Completing the Reduction: Streaming to Communication Protocol	41
6	Communication Upper Bounds	42
6.1	Warm-Up: An $\tilde{O}(n\sqrt{n})$ Communication Protocol	43
6.2	An $\tilde{O}(n)$ Communication Protocol	44
	Acknowledgements	46
	Bibliography	46
A	Sampling Bounds	53
B	Proof of Propositions Regarding Triangular Discrimination	53
C	Proof of Claim 4.23	55
D	Proof of Lemma 5.3	57
E	Background on Information Theory	57
E.1	Useful Properties of Entropy and Mutual Information	58
E.2	Background on Communication and Information Complexity	59

1 Introduction

Graph streaming algorithms process their inputs by making one or few passes over the edges of an input graph using limited memory. Algorithms that use space proportional to n , the number of vertices, are called *semi-streaming* algorithms. Since their introduction by [FKM⁺05], graph streaming algorithms have become one of the main theoretical research areas on processing massive graphs. We refer the interested reader to [McG14] for an introductory survey of earlier results on this topic.

In this work, we prove a polynomial-pass lower bound for any graph streaming algorithm that computes k -cores or degeneracy of a given graph. Our result is of interest from the point of view of proving strong lower bounds in the graph streaming model in addition to their direct implications for these two specific problems.

1.1 Polynomial Pass Lower Bounds in Graph Streams

Even though the study of multi-pass graph streaming algorithms started hand in hand with single-pass algorithms in [FKM⁺05], our understanding of powers and limitations of multi-pass algorithms, even for most basic problems, lags considerably behind. On one hand, for a problem like minimum cut, we have algorithms that in just $\tilde{O}(n)$ space and two passes can solve the problem *exactly* [AD21]¹ (see [ACK19, Table 1] for a list of several such results). On the other hand, for some other basic problems such as undirected shortest path, directed reachability, and bipartite matching, the best known semi-streaming algorithms require $O(n^{1/2})$ [CFHT20], $n^{1/2+o(1)}$ [LJS19, AJJ⁺22], and $n^{3/4+o(1)}$ [AJJ⁺22] passes, respectively; yet, despite significant efforts, the best lower bound for any of these problems is still (even slightly below) $\Omega(\log n)$ passes [GO13, CGMV20, AR20, CKP⁺21a].

A key reason behind our weaker understanding of multi-pass streaming algorithms can be attributed to the lack of techniques for proving *super-logarithmic* pass lower bounds for semi-streaming algorithms. At this point, such lower bounds are only known for a handful of problems: clique and independent set [HSSW12], dominating set [A17], Hamiltonian path [BCD⁺19], maximum cut [BCD⁺19, KPSY23], vertex cover and coloring [ACKP21], exact Boolean CSPs [KPSY23], triangle detection [PS84, BKS02], and diameter computation [FHW12]. Although, for all these problems, we can actually prove close-to- n pass lower bounds. Let us examine this dichotomy.

A quick glance at the list of problems above may suggest an intuitive difference between these problems and the ones like reachability or shortest path: the above list consists of problems that are computationally hard in a classical sense², suggesting that we are dealing with a “harder” class of problems in their case. While this intuition should not be taken as a formal evidence—as classical computational hardness does *not* imply streaming lower bounds (which are unconditional and information-theoretic)—[ACK19] showed that one can also formally explain this dichotomy.

In particular, [ACK19] observed that these strong streaming lower bounds happen only when the communication complexity of the problem at hand is $\Omega(n^2)$. Such a high lower-bound on the communication complexity *immediately* gives an $\tilde{\Omega}(n)$ -pass lower bound for semi-streaming algorithms via standard reductions. Whereas, for almost all problems of interest in the semi-streaming model, including shortest path, reachability, and bipartite matching, we already know an $\tilde{O}(n)$ communication upper bound³ (the protocol for bipartite matching was only discovered in [BvdBE⁺22] after the work of [ACK19], but $\tilde{O}(n^{3/2})$ communication protocols were known

¹See [RSW18] for an implicit algorithm with the same bounds and [MN20] for the extension to weighted cuts in $O(\log n)$ passes.

²These are standard NP-hard problems or admit some fine-grained hardness (for the latter two) [RW13, KPP16].

³This perhaps can be seen as this: a problem whose (unbounded round) communication complexity is already high has almost no place in the streaming model, which is a much weaker model algorithmically.

already [IKL⁺12, DNO19]). We refer the reader to [ACK19, Section 1.1] for more context regarding these observations and prior techniques for $o(\log n)$ pass lower bounds.

Toward Stronger Streaming Lower Bounds

A natural question in light of these observations, already posed in [ACK19], is the following:

Motivating question. *Is there any graph problem which is “not too hard”, in that it can be solved efficiently with communication (nearly) linear in the number n of vertices, and for which, nonetheless, any semi-streaming algorithm needs a polynomial $n^{\Omega(1)}$ number of passes?*

To address this question, [ACK19] introduced a new (four-player) communication problem called **Hidden Pointer Chasing (HPC)**, which acts as a cross between *Set-Intersection* and *Pointer Chasing* problems, which are the main problems for, respectively, proving $\Omega(n^2)$ communication lower bounds on graphs, and $o(\log n)$ -pass lower bounds for semi-streaming algorithms.

Roughly speaking, the HPC problem is defined as follows. There are four players paired into two groups. Each pair of players inside a group shares m instances of the Set-Intersection problem on m elements (each of the two players holds a subset of $[m]$ and they need to identify the unique intersecting element). The intersecting element in each instance of each group “points” to an instance in the other group. The goal is to start from a fixed instance, follow these pointers for a fixed number of steps, and then return the last element reached. See Definition 3.3 for the formal description.

This problem admits an efficient communication protocol with no limit on its number of rounds, but [ACK19] showed that any r -round protocol that aims to find the $(r + 1)$ -th pointer in HPC requires $\Omega(m^2/r^2)$ communication. This places HPC squarely in the middle of previous techniques and quite suitable for performing reductions to prove streaming lower bounds even for not-too-hard graph problems. Using this, [ACK19] proved the first set of polynomial-pass graph streaming lower bounds in this class of problems: computing *lexicographically-first maximal independent set (LFMIS)* and *s - t minimum cut* on graphs with exponential edge-capacities both require $\tilde{\Omega}(n^{1/5})$ passes to be solved by semi-streaming algorithms.

Despite the significant advances on multi-pass streaming lower bounds in the last couple of years [CGMV20, AKSY20, AR20, CKP⁺21a, AN21, CKP⁺21b, AKZ22, KPSY23, CKP⁺23, A22], there is still no other known (not-too-hard) problem that admits a polynomial-pass lower bounds beside those of [ACK19]. In addition, it is worth mentioning that, strictly speaking, neither LFMIS nor the version of s - t minimum cut in [ACK19] completely fit the premise of our original question: LFMIS is not purely a graph problem as it is not invariant under labeling of the vertices, and s - t minimum cut studied in [ACK19] involves (i) making the non-standard assumption of exponential capacities, and (ii) even for unit-capacity graphs, is not known to admit an $\tilde{O}(n)$ communication protocol (see [BvdBE⁺22]).

We prove polynomial-pass lower bounds for two natural graph problems, k -cores and degeneracy, by reduction from a harder variant of the HPC problem which we call MultiHPC. We also present novel $\tilde{O}(n)$ communication protocols for these two problems. These two results together give us the first natural instances of a positive answer to our motivating question.

These results further demonstrate the power of reductions from the HPC problem, as a technique for proving strong lower bounds in the graph streaming model, which are beyond the reach of other techniques. With this in mind, we improve the lower bound of [ACK19] for the HPC problem to an optimal bound of $\Omega(m^2/r)$ communication, i.e., we improve the known bound by a factor of r . This contribution alone results in a polynomial improvement in the number of passes, for all lower

bounds that follow via reductions from HPC (for instance, it immediately improves the bounds of [ACK19] for LFMIS and exponential-capacity s - t minimum cut to $\tilde{\Omega}(n^{1/4})$ passes).

But, as it turns out, all the known lower-bounds that follow by reduction from HPC also follow by reduction from MultiHPC. For this variant, we can prove an $\Omega(m^2)$ lower-bound for r rounds (since the input size for MultiHPC is $r \cdot m^2$), and this translates to an improved semi-streaming lower-bound of $\tilde{\Omega}(n^{1/3})$ passes for all of the above problems.

1.2 k -Cores and Degeneracy in Graph Streams

For any undirected graph $G = (V, E)$ and integer $k \geq 1$, a k -core in G is a maximal set S of vertices such that the induced subgraph of G on S , denoted by $G[S]$, has a minimum degree of at least k . In other words, any vertex in S has at least k other neighbors in S .

k -Cores provide a natural notion of well-connectedness in massive graphs, and as such, computing k -cores (and more generally k -core decompositions; see, e.g., [LSY⁺22]) has been widely studied in databases [BGKV14, CZL⁺20, LZZ⁺19], social networks [DBS17, DBS18, KBVT15], machine learning [ADBV05, ELM18, GLM19], among others [LWSX18, GBGL20, SGJ⁺13].

As a result, in recent years, there has been a rapidly growing body of work on computing k -cores on massive graphs in parallel and streaming models of computation [SGJ⁺13, DBS17, DBS18, ELM18, GLM19, LSY⁺22]. In particular, [ELM18] presented a single-pass algorithm that for any $\varepsilon > 0$, computes a $(1 - \varepsilon)$ -approximation of every k -core in G (i.e., obtains a $(1 - \varepsilon)$ -approximate k -core decomposition) in $\tilde{O}(n/\varepsilon^2)$ space (see also [SGJ⁺13] for an earlier streaming algorithm and [GLM19] for a closely related parallel algorithm).

The *degeneracy* of a graph $G = (V, E)$, denoted by $\kappa(G)$, is the largest integer $k \geq 0$ such that G contains a non-empty k -core. The simple greedy algorithm that at every step peels off the smallest degree vertex results in the so-called *degeneracy ordering* of G and $\kappa(G)$ is equal to the largest degree of a vertex removed in this peeling process [MB83]. Degeneracy is a standard measure of uniform sparsity and is closely related to other such notions like arboricity (which is within a factor 2 of degeneracy). Moreover, computing degeneracy is a subroutine for approximating various other problems such as arboricity [AYZ97], densest subgraph [Cha00], $(\kappa + 1)$ coloring [EH66].

The degeneracy problem, and closely related uniform-sparsity measures such as densest subgraph, have also been studied extensively in the graph streaming literature [BKV12, FT14, BHNT15, MTVV15, FT16, BCG20, AA20]. In particular, [FT14] provided an $O(\log n)$ -pass semi-streaming algorithm that outputs a constant factor approximation to degeneracy, and [FT16] subsequently improved this to a single-pass $(1 - \varepsilon)$ -approximation in $\tilde{O}(n/\varepsilon^2)$ space (see also [MTVV15] for densest subgraph and [BCG20, AA20] for degeneracy coloring).

In terms of lower bounds, [BCG20] prove that any *single-pass* streaming algorithm that computes the exact value of degeneracy or approximates it within an additive factor of λ requires $\Omega(n^2)$ space or $\Omega(n^2/\lambda^2)$ space respectively. Our *polynomial-pass* lower bounds for k -cores and degeneracy, now in a very strong sense, rule out the possibility of extending any prior semi-streaming algorithms computing near-optimal solutions to these problems, to compute *exactly* optimal solutions.

1.3 Our Results

We give an informal presentation of our results here and postpone the formal descriptions to subsequent sections. The first main result is our polynomial-pass lower bound for k -core computation and degeneracy.

Result 1 (Formalized in Theorem 5.1). For any integer $p \geq 1$, any p -pass streaming algorithm for computing the degeneracy of an input n -vertex graph requires $\tilde{\Omega}(n^2/p^3)$ space. In particular, any semi-streaming algorithm for the problem requires $\tilde{\Omega}(n^{1/3})$ passes. Moreover, the same lower bounds also apply to the algorithms that given any integer $k \geq 1$, can check whether or not the input graph contains a non-empty k -core.

Result 1 provides a strongly negative answer to the question of obtaining semi-streaming algorithms for exact computation of degeneracy and k -cores in a small number of passes. We obtain Result 1 via a detailed and technical reduction, presented in Section 5, from a variant of the Hidden Pointer Chasing (HPC) problem of [ACK19], which we call Boolean Multilayer Hidden Pointer Chasing (BMHPC).

In a standard HPC problem, we are given m instances of m -bit Set-Intersection ($O(m^2)$ bits in total) and interpret the intersection point of each instance as pointing to a different instance among these m . We then wish to know the position we end up in after following $r + 1$ pointers. In a Boolean variant, we only care to know the *parity* of the position we end up in. In a Multilayer variant, we are given r different layers, each layer with its own m instances (rm^2 bits in total), where we think of the intersection points at each layer as pointing to some instance in the next layer, and wish to know where we end up in the last layer by following these pointers.

In addition to the reduction from BMHPC, in Section 6, we present a novel and non-trivial communication protocol that finds the degeneracy ordering (and thus degeneracy itself) and non-empty k -cores for any given k , using only $\tilde{O}(n)$ communication. This communication upper bound thus places the k -core and degeneracy problems as perfect illustrations of a positive answer to our and [ACK19]’s motivating question outlined earlier: namely, problems that prior techniques could not have proven any lower bound beyond $\log n$ passes. Result 1 thus constitutes the first set of natural graph problems with polynomial pass lower bounds for semi-streaming algorithms.

Our second main contribution is providing optimal lower bounds for the HPC problem and all its variants (Boolean, Multilayer, and Boolean Multilayer). A communication lower-bound of $\Omega(\frac{m^2}{r^2})$ was previously known for $(r - 1)$ -round protocols computing the r -th pointer in a (single layer) HPC problem. We prove the following.

Result 2 (Formalized in Theorem 4.2). For any integer $1 \leq r = O(\sqrt{m})$, any $(r - 1)$ -round protocol for computing the r -th pointer in the HPC problem on a universe of size m requires $\tilde{\Omega}(m^2/r)$ communication.

For any integer $r \geq 1$, any $(r - 1)$ -round protocol for computing the r -th pointer in the Multilayer HPC problem on a universe of size m requires $\tilde{\Omega}(m^2)$ communication.

Moreover, the same lower bounds hold for the Boolean versions of the above.

Result 2, by strengthening the lower bound of [ACK19], allows us to prove polynomially stronger bounds on the number of passes of semi-streaming algorithms via reductions from HPC. As it turns out, every known reduction from HPC [ACK19] can be easily converted to a reduction from MHPC. Our results thus imply improved pass lower bounds (from $\tilde{\Omega}(n^{1/5})$ to $\tilde{\Omega}(n^{1/3})$) for semi-streaming algorithms solving these problems. We capture this in the next corollary.

Corollary 1.1. *For any integer $p \geq 1$, any p -pass streaming algorithm for the following problems on n -vertex graphs requires $\tilde{\Omega}(n^2/p^3)$ space. In particular, any semi-streaming algorithm for these problems require $\tilde{\Omega}(n^{1/3})$ passes.*

- *Computing the minimum s - t cut value in a weighted graph (with exponential edge capacities)*

- *Computing the lexicographically-first maximal independent set (LFMIS) of an undirected graph*

We obtain Result 2 by following the elegant analysis of pointer chasing problems due to [Yeh20] via the *triangular discrimination distance* between distributions, as opposed to more standard measures such as KL-divergence and total variation distance typically used in this context. This in turn requires extending the notion of “almost solving” for the Set-Intersection problem introduced by [ACK19] (and further refined in [AR20]), to the triangular discrimination distance: roughly speaking, this corresponds to proving a lower bound for communication protocols that, instead of finding the intersecting element, change its distribution slightly from uniform distribution. The analysis in [ACK19] measured this change by total variation distance, but now we need to do so by triangular discrimination distance instead. Finally, we prove a nearly-optimal lower bound on the communication-distance tradeoff for almost solving Set-Intersection in terms of the triangular discrimination distance.

2 Overview

2.1 Hidden Pointer Chasing

The Multilayer Hidden Pointer Chasing (MHPC) problem, the starting point of our reductions, is defined as follows. The problem operates on two disjoint universes $\mathcal{X} = \{x_1, \dots, x_m\}$ and $\mathcal{Y} = \{y_1, \dots, y_m\}$. There are four players P_A, P_B, P_C, P_D , out of which P_A and P_B each hold rm subsets of \mathcal{Y} , called A_x^j and B_x^j for $x \in \mathcal{X}$ and $j \in [r]$, and P_C and P_D each hold rm subsets of \mathcal{X} , called C_y^j and D_y^j for $y \in \mathcal{Y}$ and $j \in [r]$, with the promise $|A_x^j \cap B_x^j| = 1$ and $|C_y^j \cap D_y^j| = 1$ for every $j \in [r]$, $x \in \mathcal{X}$ and $y \in \mathcal{Y}$. This means that each pair of sets of two of the players, e.g. A_x^j and B_x^j defines a pointer $\{y\} = A_x^j \cap B_x^j$, which we think of as pointing to the pair of sets in the next layer, C_y^{j+1} and D_y^{j+1} , belonging to the other two players. Following these pointers, and writing a singleton set as the element it contains, we define a sequence $z_0 = x_1$, $z_1 = A_{z_0}^1 \cap B_{z_0}^1$, $z_2 = C_{z_1}^2 \cap D_{z_1}^2$, $z_3 = A_{z_2}^3 \cap B_{z_2}^3$, etc. In the $\text{MHPC}_{m,r}$ problem, the players wish to learn z_r . In the $\text{BMHPC}_{m,r}$ problem, the players only need to learn one bit about z_r , that is, $b(z_r) := i \bmod 2$ where i is the index of z_r in \mathcal{X} or \mathcal{Y} . Now, there is a very obvious way of doing this in r rounds, if the correct pair of players start: the players just follow the pointers, solving the necessary Set-Intersection instances. This costs them r rounds with $O(m)$ bits of communication per round, for a total of rm bits. However, we will show:

Theorem 2.1. *Any randomized protocol with less than r rounds, or even any randomized protocol with r rounds which is misaligned, in that the “wrong” pair of players starts to speak, cannot solve $\text{BMHPC}_{m,r}$ correctly with fewer than $\Omega(m^2)$ bits of communication.*

This theorem is proven by combining ideas from three different previous works: [ACK19], [AR20], and [Yeh20]. But first, let us give an overall intuition for why it should be expected to hold.

In a misaligned r -round protocol for $\text{BMHPC}_{m,r}$, it is players P_C and P_D who begin the protocol by talking with each other. This means that the “wrong” pair of players begin to speak, in the sense that they wish to compute the value $\{z_1\} = A_1^1 \cap B_1^1$, but this instance is with P_A and P_B , so they have no way to do this. So the first round cannot say anything about z_1 : the best P_C and P_D can do is send some information about all of their Set-Intersection instances, without knowing which one is important. This means that each bit that P_C and P_D communicate with P_A and P_B in the first round can only reveal $\frac{1}{m}$ bits of information about the average instance. But now in the next round, P_A and P_B , although they know z_1 , cannot have learned much information about $C_{z_1}^2$ or $D_{z_1}^2$. But then, how can they say anything about $\{z_2\} = C_{z_1}^2 \cap D_{z_1}^2$? The difficult situation is now reversed! This “always one step behind” situation is similar to what happens for

pointer chasing [NW93, PRV99, Yeh20], except now the pointers are “hidden” behind set intersection instances.

A previous paper of Assadi, Chen and Khanna [ACK19] showed a lower-bound of $\Omega(\frac{m^2}{r^2})$ for the (single layer) Hidden Pointer Chasing problem $\text{HPC}_{m,r}$, which is a version of $\text{MHPC}_{m,r}$ where all the layers are identical ($A_i^j, B_i^j, C_i^j, D_i^j$ is the same for all $j \in [r]$). The lower-bound was proven via an information-theoretic argument. They first show that any low-round protocol for HPC must be “almost solving” a set intersection instance on one of the rounds. They then show that this is impossible via an information complexity argument, akin to the lower-bound on the information complexity for set disjointness. However, a later paper by Assadi and Raz [AR20] directly showed that any protocol that “almost solves” set intersection can be used to obtain a protocol that exactly solves set intersection (hence the term “almost solving”). This would allow us to replace the *ad hoc* information complexity argument in [ACK19], and instead appeal, in a black-box fashion, to a previously known lower-bound on the information complexity of Set-Intersection [JKS03].

One could take these previous lower-bounds for $\text{HPC}_{m,r}$, and prove a lower-bound of $\Omega(\frac{m^2}{r})$ for $\text{MHPC}_{m,r}$, but not the lower-bound of $\Omega(m^2)$ which we obtain here. The insufficiency of these previous proofs comes from the notion of “almost solving” that is used. There, a protocol is said to “almost solve” Set-Intersection if the distribution of the intersection point is sufficiently changed by the knowledge gained from the protocol’s execution. More precisely, if the distribution of the intersection point $\mu(A \cap B \mid \Pi)$, conditioned on knowing the transcript Π , is sufficiently far away, in total variation distance (TVD), from the distribution of the intersection point $\mu(A \cap B)$, as it is known before the protocol begins. The quadratic margin in terms of r is ultimately a result of the quadratic loss between TVD and Shannon information, in the use of Pinsker’s inequality.

This same issue was the cause of a decades-long open problem on the complexity of (non-hidden) pointer chasing. Nisan and Wigderson proved in 1991 [NW91] that any r -round protocol for pointer chasing, where the wrong player starts, needs to communicate $\omega(\frac{m}{r^2})$ bits. But there is a simple upper bound of $O(\frac{m}{r})$. In 2000, Klauck [Kla00] gave a non-constructive proof of a matching lower-bound. That is, he showed that the randomized communication complexity is indeed $\Omega(\frac{m}{r})$, but without providing a hard distribution, which must exist via Yao’s Principle. This problem remained open until 2019, when Yehudayoff [Yeh20] showed that the distributional complexity of pointer chasing is $\Omega(\frac{m}{r})$ under the uniform distribution, whenever $r \ll \sqrt{m}$. The proof used a measure of information called *triangular discrimination*, which had never before been used in the lower-bounds literature.

Thus, being simultaneously aware of the three works of [ACK19], [AR20], and [Yeh20], one is naturally led to ask if they can be combined in such a way as to improve the $\frac{m^2}{r^2}$ lower bound for HPC, to $\frac{m^2}{r}$? And could we then prove a lower bound of $\Omega(m^2)$ for Multilayer HPC?

This turns out to be the case. We are not only able to prove Theorem 2.1, but we also improve the lower bound for (single layer) HPC:

Theorem 2.2. *Let $r = O(\sqrt{m})$. Then, any randomized protocol with less than r rounds, or even any misaligned randomized protocol with r rounds, cannot solve $\text{BHPC}_{m,r}$ correctly with fewer than $\Omega(\frac{m^2}{r})$ bits of communication.*

The key insight in the new lower bounds is that the notion of “almost solving” an instance of Set-Intersection can be adapted to use triangular discrimination instead of TVD. Two issues then need to be addressed.

First, we must show that a low-round protocol for HPC or MHPC must be “almost solving” (in the new sense) an instance of Set-Intersection in one of the rounds. The proofs follows the general outline of [ACK19], but need to be adapted to use triangular discrimination instead of TVD. To see that it works, one must first understand that triangular discrimination obeys a property analogous to TVD, saying that the expected value of $f(x)$, when x is sampled by some distribution μ , is not

too far from the expected value of $f(x)$ when x is sampled by a different distribution ν , if μ and ν are close with respect to triangular discrimination. This is obvious for TVD, but not as obvious for triangular discrimination. It is also not obvious how to adapt the proof to Multilayer HPC, in a way that works for any number of rounds $r \leq m$.

Second, we must show that a low-information protocol that “almost solves” (in the new sense) Set-Intersection can still be used to obtain a low-information protocol that exactly solves Set-Intersection. The proof is similar to [AR20]. In that paper, a reduction is given which solves a given Set-Intersection instance by sampling $O(1)$ runs of a protocol that “almost solves” Set-Intersection in terms of TVD. We reinterpret their reduction as using the almost-solving protocol to assign scores to elements (predicting how likely they are to be the intersecting element), and come up with a new scoring function which allows a reduction from set intersection to almost-solving with respect to positive triangular discrimination.

2.2 Reduction to Degeneracy

We give a high-level overview of the key idea behind the reduction from BMHPC to the streaming problem of finding the graph degeneracy. First, suppose that we want to show a streaming lower bound for the harder problem of finding a degeneracy ordering. In the classical offline setting, we can obtain such an ordering by the peeling algorithm that recursively removes the min-degree node from the graph and appends it to the end of the ordering. But naively implementing this algorithm in the semi-streaming setting seems difficult since it is inherently sequential. We can store the degree of each node in semi-streaming space and find the min-degree node v in the graph. After we remove v , we need to find a min-degree node v' in the new graph $G \setminus \{v\}$. But at the beginning of the stream, we did not know which node v is, and hence might not have stored enough of its neighbors so as to update their degrees and find v' . Hence, naively, we need to make a new pass for each peeled vertex, which takes $\Theta(n)$ passes in total for an n -node graph. One might wonder whether *any* semi-streaming algorithm for degeneracy ordering would need close to these many passes. If so, how do we prove it?

Consider just the basic problem of finding a min-degree node in an n -node graph, which is the primitive for finding a degeneracy ordering. It can be shown via a simple reduction that a streaming algorithm for this problem can be used to solve SetInt_n , the Set-Intersection communication problem with universe size n . As noted above, finding the degeneracy ordering translates to finding a sequence of nodes that have smallest degree in the remaining graph. This means we can use it to basically solve a sequence of $\text{SetInt}_{\Theta(n)}$ instances. These instances are, however, not independent. The solution to the first instance gives a min-degree node in the original graph, whose removal leads to the second instance; solving this instance reveals the third instance, and so on and so forth. This gives a flavor of a combination of SetInt and pointer chasing, where each pointer is revealed by solving a SetInt instance corresponding to the previous pointer. This is precisely the concept behind HPC (or MHPC for that matter)! Hence, it is plausible that the degeneracy ordering problem can be reduced from MHPC, and we embark on the journey to find such a reduction.

Recall the definition of MHPC from Section 2.1. Given an instance of MHPC, we construct the following layered graph with $r + 1$ layers L_0, \dots, L_r . Each layer has m nodes: the nodes in the even layers correspond to x_i 's and the ones in the odd layers correspond to y_i 's. The edges of the graph are always between two consecutive layers. The players P_A and P_B encode the sets $A_{x_i}^1$ and $B_{x_i}^1$ by adding edges between L_0 and L_1 . Consider the following encoding: for each $i, j \in [m]$, if $y_j \in A_{x_i}^1$, then P_A adds an edge from the i th node in L_0 to the j th node in L_1 . P_B does the analogous construction for the elements in $B_{x_i}^1$ (note that this can lead to parallel edges). P_C and P_D encode the sets $C_{y_i}^2$ and $D_{y_i}^2$ by adding edges between L_1 and L_2 in the analogous way. Again, P_A and P_B encode $A_{y_i}^3$ and $B_{y_i}^3$ with edges between L_2 and L_3 , and this proceeds alternately until

the relevant players add the edges between L_r and L_{r+1} .

Let v_0 be the first node in L_0 ; recall that it corresponds to $x_1 = z_0$. Assume that v_0 is the min-degree node in the graph with $\deg(v_0) = d - 1$ and all other nodes have the same degree d . Again, recall that $z_1 = A_{z_0}^1 \cap B_{z_0}^1$. By construction and by the unique-intersection promise of the **SetInt** instances of MHPC, v_0 has two parallel edges to the node representing z_1 in L_1 ; call this node v_1 . To all other nodes in L_1 , v_0 has at most one edge. Hence, when the peeling algorithm deletes v_0 from the graph, only the degree of v_1 drops by 2, i.e., $\deg(v_1)$ becomes $d - 2$; all other nodes have at most a drop of 1 in degree, i.e., have degree $\geq d - 1$. Thus, v_1 becomes the new min-degree node in the graph. Now, when v_1 is deleted, by similar logic, the node v_2 in L_2 , corresponding to the element $z_2 = C_{z_1}^2 \cap D_{z_1}^2$, becomes a min-degree node in the remaining graph with $\deg(v_2) = d - 2$. However, now some node in L_0 might also have degree $d - 2$; this is the case when $z_1 = A_{x_i}^1 \cap B_{x_i}^1$ for some $i \neq 1$ as well. Now assume that the peeling algorithm breaks ties by choosing a node in the highest layer among all min-degree nodes (and arbitrarily within the highest layer). Then, indeed it chooses v_2 as the next node to peel (since it is the unique min-degree node in L_2 , again by the **SetInt** promise). Thus, it follows inductively that the i th iteration of the peeling algorithm removes the node corresponding to z_{i-1} in L_{i-1} . Hence, the $(r + 1)$ th node in the degeneracy ordering can be used to identify z_r .

The above high-level idea has quite a few strong assumptions. The challenge is now to get rid of them. We list these challenges and then describe how we overcome them.

- (i) The constructed graph has parallel edges. Then the reduction would only prove a lower bound against algorithms that can handle multigraphs, which is much weaker than a lower bound against algorithms that work on simple graphs.
- (ii) We assume that the tie-breaking is done by the peeling algorithm so as to pick a vertex in the highest layer. It is not at all clear how to get rid of this assumption in a straightforward way.
- (iii) We also assume that we can set the initial degrees in such a way that v_0 has degree $d - 1$ and all other nodes have degree d . It is not clear that we can do this while preserving the relevant properties of the construction.
- (iv) Even if we can overcome the above challenges and the reduction goes through, then we prove a lower bound for finding degeneracy ordering, which is (at least formally) harder than the problem of finding the degeneracy value. Ideally we would like to show the lower bound for the simplest variant of the problem: checking whether degeneracy of the graph is smaller than a given value k or not.

To get around (i), we modify the construction to have a pair of nodes represent each element. The edge construction is done in the following way. Suppose the pair (u_1, u_2) represents an element x_i in layer $\ell - 1$, and (w_1, w_2) represents y_j in layer ℓ . If $y_j \in A_{x_i}^\ell$, then we add edges from u_1 to both w_1 and w_2 . Similarly, if $y_j \in B_{x_i}^\ell$, then we add edges from u_2 to both w_1 and w_2 . Note that if $y_j \in A_{x_i}^\ell \cap B_{x_i}^\ell$, then we have all 4 cross edges between the two pairs, and otherwise we have only 2 edges between them, one on each w_i . Hence, when u_1 and u_2 are removed, both w_1 and w_2 lose degree by 2 if y_j is the intersecting element, and otherwise they only lose degree by 1. This captures the property of the reduction that we want, without constructing parallel edges.

For (ii), we do something more elaborate. On a high level, we duplicate each of the layers L_1, \dots, L_r to provide a “padding” between two initially-consecutive layers. This padding has additional nodes that create an asymmetry between the layer preceding it and the one succeeding it. This asymmetry ensures that the degrees of the nodes in the higher layer drop more than those in the lower layer. Then, we can proceed with the peeling algorithm as planned.

To handle (iii), we show that once we are done with the construction based on the MHPC instance, we can consider each node, look at its degree, and add edges from it to some auxiliary vertices so as to reach its “target degree”. We need to be careful about two things: one, we preserve the properties of the construction so that the reduction goes through, and two, we do not add too many new nodes that might make the bound obtained from the reduction weak. We succeed in achieving a construction without violating the above.

Finally, for (iv), we observe that while we gave the above outline for a reduction from MHPC, the “easier” boolean version BMHPC has a similar lower bound. We then succeed in extending the ideas to reduce the boolean problem of “checking whether degeneracy $\leq k$ ” from the BMHPC problem, thus obtaining the desired lower bound for this simple variant. For reduction from BMHPC, where the goal is to output just the bit $b(z_r)$ (see definition in Section 2.1) rather than z_r , we need to make non-trivial modifications in the graph: we join the nodes which represent the bit-1 elements in the last layer, to some “special nodes” S . The other nodes in the last layer are not joined to them. The special nodes are also adjacent to all nodes in the other layers. We show that if $b(z_r) = 1$, then after the peeling algorithm removes the nodes corresponding to z_r in the last layer, the degrees of the special nodes drop enough such that all the remaining vertices get peeled one by one, while having degree at most some value k during deletion. This implies that the graph has degeneracy $\leq k$. Otherwise, if $b(z_r) = 0$, we show that after peeling off the nodes representing z_r in the last layer, the minimum vertex-degree in the remaining subgraph is at least $k + 1$, implying that the degeneracy of the graph must be at least $k + 1$. We give the detailed reduction and proof in Section 5.

2.3 Communication Upper Bounds for Degeneracy

We give a short overview of the $\tilde{O}(n)$ communication protocol for computing the degeneracy of a graph. In the two player communication model, the edges of the input graph G are split into two disjoint sets E_A and E_B given to the players Alice and Bob respectively, and they wish to find the degeneracy of G . Note that the search problem (finding the degeneracy) reduces to its decision counterpart (is the degeneracy $\leq k$?) by a binary search, costing only a $\log n$ multiplicative factor in the communication cost. Hence, we focus on the version where Alice and Bob are additionally given an integer k , and wish to decide if the degeneracy of G is at most k .

To solve this decision problem, we implement the following version of the peeling algorithm in a communication protocol: while there is a vertex of degree $\leq k$, remove it. If the graph is non-empty at the end, reject, otherwise accept. The main challenge in adapting this algorithm is that in the worst case, it seems to update the degree of almost all vertices in G after each deletion, and there is no way to do that without a lot of communication.

However, we observe that if a vertex has degree at least $k + \sqrt{n}$, then it cannot be deleted for the next \sqrt{n} iterations (since each iteration can reduce its degree by at most one). This observation alone gives us the following $\tilde{O}(n\sqrt{n})$ communication protocol:

1. Compute the degree of each vertex in G .
2. Ignore all vertices of degree $\geq k + \sqrt{n}$ while performing \sqrt{n} rounds of the trivial peeling algorithm.
3. Go to Step 1.

Note that the communication in Step 2 comes from Alice and Bob sending each other the low degree ($< k + \sqrt{n}$) neighbors of the vertex deleted in each iteration of the peeling algorithm. We observe that while a vertex has degree $\geq k + \sqrt{n}$, it is not listed in Step 2, and once its degree falls below the threshold of $k + \sqrt{n}$, it is listed at most \sqrt{n} times due to Step 2. Thus, the total communication due to Step 2 over the course of the entire protocol is bounded by $\tilde{O}(n\sqrt{n})$. Also,

we recompute the degrees of *all* vertices (which costs $O(n \log n)$ communication each time) at most \sqrt{n} times; these two facts combined give us the desired bound.

To get an improved $\tilde{O}(n)$ communication protocol, we extend the idea above to partition the vertices into $\log n$ sets, where the i -th set contains vertices of degree between $k + 2^{i-1}$ and $k + 2^i$. While the global approach (of simply ignoring the high-degree vertices for \sqrt{n} steps) does not work any more, we are able to make a more local argument as follows: for a vertex of degree $k + \ell$ to be deleted, it must lose at least ℓ neighbors, which means it must lose $\ell/2$ neighbors in either Alice’s or Bob’s edge set. But now the players can just track this “private” loss of degree of each vertex, and communicate to update the degree of a vertex in the i -th set only when either private degree falls by at least 2^{i-2} . We are able to show that the degree of each vertex is updated $O(\log n)$ times over the entire course of this new protocol, and hence the total communication is $\tilde{O}(n)$. We further show that this can be extended to finding a k -core of the graph with $\tilde{O}(n)$ communication. Thus, we establish finding degeneracy and k -core as not-too-hard problems.

3 Preliminaries

3.1 The Set-Intersection Problem

Definition 3.1. The m -bit **Set-Intersection** problem is a communication problem for two players Alice and Bob. Alice is given a subset $X \subseteq [m]$ and Bob is given a subset $Y \subseteq [m]$, with the promise that $|X \cap Y| = 1$. Their goal is to learn the point of intersection $\{t\} = X \cap Y$.

Let us define a distribution $\mathcal{D}_{\text{Set-Int}}$ over inputs for Set-Intersection. This is the positive case of Razborov’s original hard distribution for disjointness [Raz92].

Distribution $\mathcal{D}_{\text{Set-Int}}$ [AR20] on sets (X, Y) from the universe $\mathcal{X} = [m]$:

- Uniformly sample two disjoint sets $X', Y' \subseteq [m]$ of size $\frac{m}{4} - 1$.
- Sample $e^* \in [m] \setminus (X' \cup Y')$ uniformly at random and define $X = X' \cup \{e^*\}$ and $Y = Y' \cup \{e^*\}$.

Proposition 3.2. *The internal information complexity of finding the intersecting element in a SetInt_m instance sampled from $\mathcal{D}_{\text{Set-Int}}$ is $\Omega(m)$.*

Proposition 3.2 is not directly implied by standard set-intersection lower bounds, since they use distributions where X and Y never intersect. To obtain this proposition, one can (for example) apply the result of [JKS03] on the information cost of set disjointness protocols on intersecting distributions (see [ACK19] for more details).

3.2 The (Boolean) Hidden Pointer Chasing Problem

The Hidden Pointer Chasing (HPC) problem is a composition of Pointer Chasing and Set-Intersection, defined as follows.

Definition 3.3. The **Hidden Pointer Chasing** (HPC) problem is a communication problem with four players P_A, P_B, P_C , and P_D . Let $\mathcal{X} := \{x_1, \dots, x_m\}$ and $\mathcal{Y} := \{y_1, \dots, y_m\}$ be two disjoint universes.

- For any $x \in \mathcal{X}$, P_A and P_B are given an instance (A_x, B_x) of SetInt over the universe \mathcal{Y} where $A_x \cap B_x = \{t_x\}$ for a single target element $t_x \in \mathcal{Y}$. We define $A := \{A_{x_1}, \dots, A_{x_m}\}$ and $B := \{B_{x_1}, \dots, B_{x_m}\}$ as the whole input to P_A and P_B , respectively.

- For any $y \in \mathcal{Y}$, P_C and P_D are given an instance (C_y, D_y) of **SetInt** over the universe \mathcal{X} where $C_y \cap D_y = \{t_y\}$ for a single target element $t_y \in \mathcal{X}$. We define $C := \{C_{y_1}, \dots, C_{y_m}\}$ and $D := \{D_{y_1}, \dots, D_{y_m}\}$ as the whole input to P_C and P_D , respectively.
- We define two mappings $f_{AB} : \mathcal{X} \rightarrow \mathcal{Y}$ and $f_{CD} : \mathcal{Y} \rightarrow \mathcal{X}$ such that:

$$(a) \text{ for any } x \in \mathcal{X}, f_{AB}(x) = t_x; \quad (b) \text{ for any } y \in \mathcal{Y}, f_{CD}(y) = t_y.$$

- Let $x_1 \in \mathcal{X}$ be an arbitrary fixed element known to all players. The pointers z_0, z_1, z_2, \dots are defined inductively as

$$z_0 := x_1, \quad z_1 := f_{AB}(z_0), \quad z_2 := f_{CD}(z_1), \quad z_3 := f_{AB}(z_2), \quad \dots$$

For any integers $m, r \geq 1$, the **m -bit, r -step Hidden Pointer Chasing** problem, denoted by $\text{HPC}_{m,r}$ is defined as the communication problem of finding the pointer z_r . Meaning, we wish to output the index $i \in [m]$ such that $z_r = x_i$ (when r is even) or $z_r = y_i$ (when r is odd).

We also define a Boolean variant of HPC as follows. In the **m -bit, r -step Boolean Hidden Pointer Chasing** problem, denoted by $\text{BHPC}_{m,r}$, the goal is to output the bit $b(z_r) := i \pmod 2$, where $z_r = x_i$ or y_i depending on if r is even or odd respectively.

3.3 The (Boolean) Multilayer Hidden Pointer Chasing Problem

The Multilayer Hidden Pointer Chasing problem (MHPC) combines r instances of HPC as its input in the following manner.

Definition 3.4. The **Multilayer Hidden Pointer Chasing** (MHPC) problem is a communication problem with four players P_A, P_B, P_C and P_D . Let m, r be integers ≥ 1 . The **m -bit, r -layer MHPC** problem, denoted by $\text{MHPC}_{m,r}$ is defined as follows.

- For each $i \in [r]$, the players receive an HPC instance (A^i, B^i, C^i, D^i) , each over the disjoint universes \mathcal{X} and \mathcal{Y} of size m . Let t_x^i denote the unique element in the intersection $A_x^i \cap B_x^i$, and t_y^i the unique element in $C_y^i \cap D_y^i$.
- For each $i \in [r]$, we have the maps $f_{AB}^i : \mathcal{X} \rightarrow \mathcal{Y}$ and $f_{CD}^i : \mathcal{Y} \rightarrow \mathcal{X}$, defined as:

$$(a) \text{ for any } x \in \mathcal{X}, f_{AB}^i(x) = t_x^i; \quad (b) \text{ for any } y \in \mathcal{Y}, f_{CD}^i(y) = t_y^i.$$

- The pointers z_i are defined inductively as:

$$z_0 := x_1, \quad z_1 := f_{AB}^1(z_0), \quad z_2 := f_{CD}^2(z_1), \quad z_3 := f_{AB}^3(z_2), \quad \dots$$

The goal of the problem is to find z_r , i.e., the index $i \in [m]$ such that $z_r = x_i$ (when r is even) or $z_r = y_i$ (when r is odd).

Analogous to HPC, we define the Boolean variant of MHPC as follows. In the **m -bit, r -layer Boolean MHPC** problem, denoted by $\text{BMHPC}_{m,r}$, the goal is to output the bit $b(z_r) := i \pmod 2$, where $z_r = x_i$ or y_i depending on if r is even or odd respectively.

We remark that C^j, D^j for odd j , and A^j, B^j for even j , are redundant (they do not affect the output of the function). They are kept for notational convenience and ease of presentation.

3.4 Misaligned r -Round Protocols

We are interested in bounded-round protocols for HPC, BHPC, MHPC and BMHPC. In each round, two of the players speak with each other (P_A with P_B , or P_C with P_D), but not with the other pair of players, with a message between pairs of players triggering the next round.

Definition 3.5 (Round of $\text{HPC}_{m,r}$). An r -round protocol is a protocol where the communication is organized in rounds $1, 2, \dots, r$. A given pair of players — P_A and P_B or P_C and P_D — communicate with each other in the odd rounds (the first, third, etc rounds) and the other pair of players communicate with each other in the even rounds. Each round ends with the speaking pair of players sending a message to the other pair of players, and this marks the beginning of the next round.

It is easy to see that one can solve any of the above HPC variants by r -round protocols communicating $O(rm)$ bits, if P_A and P_B speak in the odd rounds, and P_C and P_D speak in the even rounds. We will show lower-bounds for *misaligned* r -round protocols where the *wrong* pair of players speak:

Definition 3.6. We call an r -round protocol *misaligned* if the pair of players P_C and P_D speak in the odd rounds, and P_A and P_B speak in the even rounds.

The above definitions naturally suggest that, in an r -round protocol, we should think of z_j as the pointer that the players wish to know by the end of round j . In a misaligned protocol, however, the players speaking in round j do not hold the Set-Intersection instance that needs to be solved to find z_j .

3.5 Notation and Terminology

Notation for Protocols. We use the notation $\pi_{\text{Set-Int}}$, π_{BHPC} , and π_{BMHPC} , to denote protocols for Set-Intersection, BHPC and BMHPC, respectively.

In general, we will use the upright A to denote a random variable associated with A .

Now consider a situation where we choose inputs (A, B, C, D) from some distribution on inputs to $\text{HPC}_{m,r}$. We then let Z_1, \dots, Z_r denote random variables with values z_1, \dots, z_r of Definition 3.3. We use the variable $j \in [r]$ to index the rounds of a r -round protocol. For any $j \in [r]$, we define Π_j as the set of all messages communicated in round j , and more generally Π denotes the entire protocol transcript.

For any $x \in \mathcal{X}$ and $y \in \mathcal{Y}$, we define random variables $T_x \in \mathcal{Y}$ and $T_y \in \mathcal{X}$ giving the intersecting elements of the Set-Intersection instance (A_x, B_x) and (C_y, D_y) , respectively. We define $E_j = (\Pi_1, \dots, \Pi_{j-1}, Z_1, \dots, Z_{j-1})$ to include all messages exchanged before round j , together with the entire path followed by the pointers before round j . Note that during round j , the players wish to compute the intersection $A_{z_j} \cap B_{z_j}$ (or $C_{z_j} \cap D_{z_j}$), so knowing E_j should not help them to do that. (Note that E_1 is empty.)

On an input (A, B, C, D) to $\text{BMHPC}_{m,r}$, we define the notation $Z_i, j, \Pi_j, T_x^j, T_y^j$ analogously.

If we have random variables A, B , we will broadly use the notation $\mu(A \mid B)$ to mean “the distribution of A , conditioned on the value of B that occurred”. So, for example, if B is constant we may write $\mu(A)$, and this is some fixed distribution. But if B is non-constant, the distribution $\mu(A \mid B)$ may vary depending on B , and so $\mu(A \mid B)$ is itself also a random variable, which depends on B and can be determined by knowing B alone (even without knowing A).

Other notation. An input graph to a streaming algorithm will usually be called $G = (V, E)$ and n will denote $|V|$. The degeneracy of graph G will be denoted by $\kappa(G)$, or simply κ if the graph is clear from the context. The notation “ $\log x$ ” stands for $\log_2 x$. For a positive integer a , the notation $[a]$ denotes the set $\{1, 2, \dots, a\}$ and for integers $a < b$, $[a, b]$ denotes the set $\{a, a + 1, \dots, b\}$.

3.6 Positive Triangular Discrimination

Definition 3.7 (Positive triangular discrimination). Given two distributions μ and ν on a sample space Ω , the *positive triangular discrimination* $\Lambda(\mu, \nu)$ is:

$$\Lambda(\mu, \nu) = \sum_{\substack{x \in \Omega \\ \mu(x) > \nu(x)}} \frac{(\mu(x) - \nu(x))^2}{\mu(x) + \nu(x)}.$$

In this paper, we work exclusively with *positive* triangular discrimination. Below we state some of the useful properties of positive triangular discrimination. We defer the proofs of the following propositions to Appendix B.

Proposition 3.8. $0 \leq \frac{\|\mu - \nu\|_1^2}{8} \leq \Lambda(\mu, \nu) \leq \frac{\|\mu - \nu\|_1}{2} \leq 1.$

The following property is already implicit in [Yeh20], but making it explicit now simplifies the presentation later. Note that an analogous equation for total variation distance, i.e., $\mathbb{E}_\mu[f(x)] \leq \|\mu - \nu\|_1 \cdot \max_{x \in \Omega} f(x) + \mathbb{E}_\nu[f(x)]$ can be obtained almost from the definition. The following statement, however, needs a bit more work.

Proposition 3.9. *For any function $f : \Omega \rightarrow \mathbb{R}_{\geq 0}$,*

$$\mathbb{E}_\mu[f(x)] \leq \Lambda(\mu, \nu) \cdot \max_{x \in \Omega} f(x) + 6 \cdot \mathbb{E}_\nu[f(x)].$$

We will also make use of the convexity of Λ .

Proposition 3.10. *Positive triangular discrimination $\Lambda(\mu, \nu)$ is convex as a joint function of the two distributions μ and ν .*

3.7 Degeneracy and k -Cores

The definition of a k -core and the degeneracy $\kappa(G)$ of a graph G can be found in Section 1.2. Here, we define some related terms that come up often in the paper. We also state some basic facts about them that we later use in our proofs.

Given an ordering σ of vertices, we say $v \prec_\sigma u$ if u appears (somewhere) after v in σ .

Definition 3.11 (Outdegree with respect to an ordering). For a graph $G = (V, E)$. given an ordering σ of vertices in V , the outdegree of a vertex v with respect to σ , denoted by $\text{odeg}_\sigma(v)$, is the number of neighbors of v that appear after it in σ . Formally,

$$\text{odeg}_\sigma(v) = |\{u \in N(v) : v \prec_\sigma u\}|$$

We can also think of it as orienting all edges (x, y) from x to y if $x \prec_\sigma y$. Then $\text{odeg}_\sigma(v)$ is the outdegree of v in the resultant oriented graph.

Definition 3.12 (k -ordering). Given a graph $G = (V, E)$, an ordering σ of vertices in V is called a k -ordering if $\forall v \in V : \text{odeg}_\sigma(v) \leq k$.

The following fact connects vertex orderings to degeneracy.

Fact 3.13 ([MB83]). *The minimum number k for which a graph G admits a k -ordering is $\kappa(G)$.*

The above fact implies that to prove that a graph has degeneracy at most k , it suffices to exhibit a k -ordering of the nodes. We now formally define *degeneracy ordering* of a graph.

Definition 3.14 (Degeneracy ordering). Given a graph $G = (V, E)$, a $\kappa(G)$ -ordering of V is called a degeneracy ordering of G .

A degeneracy ordering of a graph can be obtained by running the following “peeling algorithm” on it: starting with an empty sequence σ , recursively remove the minimum degree vertex from G and append it to σ until the graph becomes empty. Again, the maximum degree that a node has when it is peeled by this algorithm is exactly $\kappa(G)$. If not, then the peeling algorithm gives a k -ordering for some $k < \kappa(G)$ which violates Fact 3.13. Hence, we get the following fact.

Fact 3.15. *Suppose the peeling algorithm on a graph G removes its nodes in the order v_1, \dots, v_n . Define $G_0 := G$ and $G_i := G \setminus \{v_1, \dots, v_i\}$ for $i \in [n]$. Then,*

$$\kappa(G) = \max_{i \in [n]} \deg_{G_{i-1}}(v_i)$$

4 New Lower Bounds for HPC and Multilayer HPC

The two main results of this section are an $\Omega(m^2)$ lower-bound against misaligned r -round protocols for $\text{BMHPC}_{m,r}$, and an $\Omega(\frac{m^2}{r})$ lower-bound against misaligned r -round protocols for $\text{BHPC}_{m,r}$. Notice that in a misaligned r -round round protocol for $\text{BMHPC}_{m,r}$ or $\text{BHPC}_{m,r}$, it is players P_C and P_D who begin the protocol by talking with each other. This means that the “wrong” pair of players begin to speak, in the sense that they wish to compute the value $\{z_1\} = A_{z_0} \cap B_{z_0}$, but this instance is with Alice and Bob, so they have no way to do this. So the first round of communication says nothing about z_1 : the best P_C and P_D can do is send some information about all of their Set-Intersection instances, without knowing which is important. So each bit that P_C and P_D communicate with P_A and P_B in the first round, can only reveal $\frac{1}{m}$ bits of information about the average instance. So, in the next round, P_A and P_B cannot have learned what C_{z_1} or D_{z_1} are, either. But then, how can they learn z_2 ? The difficult situation is now reversed! This “always one step behind” situation is similar to what happens for pointer chasing [NW93, PRV99, Yeh20], except now the pointers are “hidden” behind set intersection instances.

How much communication must the players use in order to escape this unfortunate situation? In the case of $\text{BMHPC}_{m,r}$, it is not clear how to do this in less than $O(m^2)$ bits of communication. One can think of two strategies: either reveal an entire layer, causing the protocol to become aligned at that layer, or solve roughly $\frac{m}{r}$ set intersections instances in each layer, which will cause the protocol to become aligned (follow the pointer of a solved instance) at any given layer with probability $\frac{1}{r}$. We will prove that these two strategies are essentially optimal.

However, in the case of $\text{BHPC}_{m,r}$, it can be seen that $O(\frac{m^2}{r})$ bits of communication suffice. Indeed, P_C and P_D (who speak first) may choose $N = O(\frac{m}{r})$ of their Set-Intersection instances uniformly at random, solve them all by communicating $O(\frac{m^2}{r})$ bits, and then send the solution of all these instances to P_A and P_B . Then, in the next round, P_A and P_B begin the standard protocol for solving $\text{HPC}_{m,r}$, meaning, they compute z_1 and send it back, then P_C and P_D compute z_2 and send it back, etc. If at any point P_A and P_B compute some z_j which is among the N revealed Set-Intersection instances, then they can skip a step, and learn z_{j+2} immediately without communicating. The protocol is now aligned, and can be finished within the remaining number of rounds. The probability that the path taken crosses one of the instances revealed by P_C and P_D is $\Omega(r/N)$, which can be made arbitrarily close to 1 with our choice of N .

On the other hand, one should not expect to be able to prove any significant lower-bound when r is a sufficiently large fraction of \sqrt{n} . Indeed, in this case, the birthday paradox says that the path

being traversed will cycle with high probability. The players may then follow the path (wasting the first round entirely) until they find a cycle, and then they will immediately learn z_k .

The intuitive explanation and the upper-bounds given above will lead us to conjecture the following, necessarily tight lower-bounds, which are the main results of this section.

Theorem 4.1. *Any misaligned r -round protocol, solving $\text{BMHPC}_{m,r}$ correctly with constant probability requires $\Omega(m^2)$ bits of communication.*

Theorem 4.2. *Any misaligned r -round protocol, where $r = o(\sqrt{m})$, solving $\text{BHPC}_{m,r}$ correctly with constant probability requires $\Omega(\frac{m^2}{r})$ bits of communication.*

A weaker lower-bound of $\frac{m^2}{r^2}$ for HPC was proven in [ACK19]. Our proofs of these tight lower-bounds follow a similar strategy to the earlier proof, but with a somewhat modified protocol inspired by [Yeh20]. We begin by proving Theorem 4.2 in Section 4.3, because the proof is slightly simpler, and it is enough for our streaming lower-bounds. The proof of Theorem 4.1 appears in Section 4.5. Both proofs follow a similar outline. We first show that a short, misaligned r -round protocol for BMHPC (or BHPC) must be “almost solving” an instance of Set-Intersection on one of the rounds, while revealing little information. The notion of “almost solving” will be formally defined in Section 4.1. Then, in Section 4.4, we show that any low-information protocol for “almost-solving” Set-Intersection can be used to actually solve Set-Intersection, also with low information. Putting it all together in Section 4.6, we will find that a misaligned r -round protocol for $\text{BMHPC}_{m,r}$ communicating $o(m^2)$ bits (or for $\text{BHPC}_{m,r}$ communicating $o(\frac{m^2}{r})$ bits), would allow us to solve Set-Intersection with $o(m)$ information cost, which is known to be impossible by [JKS03].

4.1 “Almost Solving”

The notion of “almost solving” is given precisely below. Intuitively, a protocol ε -solves Set-Intersection if the distribution of the intersection point $\{e^*\} = A \cap B$ is sufficiently altered by the execution of the protocol. Meaning, the distribution of e^* conditioned on knowing the protocol (and possibly one of the inputs) is sufficiently far-away from the distribution of e^* without this knowledge. In [ACK19], the chosen notion of *sufficiently far* is the total variation distance. Here we will choose positive triangular discrimination.

Definition 4.3 (ε -solving Set-Intersection, with respect to positive triangular discrimination). Let \mathcal{D} be a distribution on inputs (A, B) for Set-Intersection. A randomized protocol π *internally ε -solves Set-Intersection* (with respect to positive triangular discrimination) on \mathcal{D} if *at least one* of the following hold true (where Π is the transcript of π , including public randomness):

$$\mathbb{E}_{\Pi, A} [\Lambda(\mu(e^* | \Pi, A), \mu(e^* | A))] \geq \varepsilon \quad \text{or} \quad \mathbb{E}_{\Pi, B} [\Lambda(\mu(e^* | \Pi, B), \mu(e^* | B))] \geq \varepsilon.$$

A protocol π *externally ε -solves Set-Intersection* on \mathcal{D} if the following holds true:

$$\mathbb{E}_{\Pi} [\Lambda(\mu(e^* | \Pi), \mu(e^*))] \geq \varepsilon.$$

Observation 4.4. *From the joint convexity of positive triangular discrimination (Proposition 3.10), it follows that for any (possibly correlated) random variables A, B, C ,*

$$\begin{aligned} \mathbb{E}_{B, C} [\Lambda(\mu(A | B, C), \mu(A | C))] &= \mathbb{E}_B \left[\sum_c \Pr[C = c] \Lambda(\mu(A | B, C = c), \mu(A | C = c)) \right] \\ &\geq \mathbb{E}_B \left[\Lambda \left(\sum_c \Pr[C = c] \mu(A | B, C = c), \sum_c \Pr[C = c] \mu(A | C = c) \right) \right] \\ &= \mathbb{E}_B [\Lambda(\mu(A | B), \mu(A))]. \end{aligned}$$

That is, removing a random variable from both conditions can only decrease the Λ -distance. In particular, if a protocol externally ε -solves Set-Intersection on some distribution \mathcal{D} , it also internally ε -solves Set-Intersection on \mathcal{D} .

Observation 4.5. *It may be felt that a more natural definition of internally ε -solving should include any eventual private randomness of the protocol π . However, noting that $\{e^*\} = A \cap B$ is a function of A and B , and that A and B are independent given Π (by Fact E.9) it follows that the distribution of e^* is independent of the private randomness of π , when given A and Π . So*

$$\mathbb{E}_{\Pi, A} [\Lambda(\mu(e^* | \Pi, A), \mu(e^* | A))] = \mathbb{E}_{\Pi, A} [\Lambda(\mu(e^* | \Pi, R_A, A), \mu(e^* | A))]$$

where R_A is Alice's randomness, and likewise on Bob's side. That is, including the private randomness gives the same definition.

4.2 Hard Distributions

Next, we define two hard distributions for $\mathcal{D}_{\text{BMHPC}}$ and $\mathcal{D}_{\text{BHPC}}$, over inputs to BMHPC and BHPC, respectively.

Distribution $\mathcal{D}_{\text{BMHPC}}$ on tuples (A, B, C, D) from the universes \mathcal{X} and \mathcal{Y} :

1. For any $i \in [r]$, and any $x \in \mathcal{X}$, sample $(A_x^i, B_x^i) \sim \mathcal{D}_{\text{Set-Int}}$ from the universe \mathcal{Y} *independently*.
2. For any $i \in [r]$, and any $y \in \mathcal{Y}$, sample $(C_y^i, D_y^i) \sim \mathcal{D}_{\text{Set-Int}}$ from the universe \mathcal{X} *independently*.

Distribution $\mathcal{D}_{\text{BHPC}}$ [ACK19] on tuples (A, B, C, D) from the universes \mathcal{X} and \mathcal{Y} :

1. For any $x \in \mathcal{X}$, sample $(A_x, B_x) \sim \mathcal{D}_{\text{Set-Int}}$ from the universe \mathcal{Y} *independently*.
2. For any $y \in \mathcal{Y}$, sample $(C_y, D_y) \sim \mathcal{D}_{\text{Set-Int}}$ from the universe \mathcal{X} *independently*.

It was shown in [ACK19] that misaligned randomized r -round protocols for $\text{HPC}_{m,r}$ need $\frac{m^2}{r^2}$ bits of communication under $\mathcal{D}_{\text{BHPC}}$. In Section 4.5, we improve this result and show that misaligned randomized r -round protocols for $\text{BHPC}_{m,r}$ (an easier problem than $\text{HPC}_{m,r}$) need $\frac{m^2}{r}$ bits of communication.

We restate the following simple observations from [ACK19] about $\mathcal{D}_{\text{BHPC}}$. Analogous statements can be made for $\mathcal{D}_{\text{BMHPC}}$.

Observation 4.6 ([ACK19]). *Distribution $\mathcal{D}_{\text{BHPC}}$ is not a product distribution. However, in this distribution:*

- (i) *The inputs to P_A and P_B are independent of the inputs to P_C and P_D , i.e., $(A, B) \perp (C, D)$.*
- (ii) *For any $x \in \mathcal{X}$, (A_x, B_x) is independent of all other $(A_{x'}, B_{x'})$ for $x' \neq x \in \mathcal{X}$. Similarly for all $y, y' \in \mathcal{Y}$ and (C_y, D_y) and $(C_{y'}, D_{y'})$.*

Based on this observation, we also have the following simple property.

Proposition 4.7 ([ACK19]). *Let π_{BHPC} be any deterministic protocol for $\text{BHPC}_{m,r}$ on $\mathcal{D}_{\text{BHPC}}$. Then, for any transcript Π of π_{BHPC} , $(A, B) \perp (C, D) \mid \Pi = \Pi$.*

Proof. Follows from the rectangle property of the protocol π_{BMHPC} (Fact E.9). In particular, the same exact argument as in the two-player case implies that if $[(A, B), (C, D)]$ and $[(A', B'), (C', D')]$ are mapped to the same transcript Π , then $[(A, B), (C', D')]$ and $[(A', B'), (C, D)]$ are mapped to Π as well. Hence, since $(A, B) \perp (C, D)$ by Observation 4.6, the inputs corresponding to the same protocol would also be independent of each other, namely, $(A, B) \perp (C, D) \mid \Pi = \Pi$. \square

4.3 Short Protocols for BMHPC Give Low-Information ε -Solvers for Set-Int

We now show that if we have a short, r -round protocol for $\text{BMHPC}_{m,r}$ on $\mathcal{D}_{\text{BMHPC}}$, then during one of its rounds it must be externally (and hence also internally) ε -solving Set-Intersection on $\mathcal{D}_{\text{Set-Int}}$, while revealing little information. This is proven by making precise the following intuitive line of thinking, the statement of which is formally captured by Lemma 4.11.

- By the end of round j , the speaking pair of players would like to have learned $\{Z_j\} = A_{Z_{j-1}}^j \cap B_{Z_{j-1}}^j$ (for odd j , or $\{Z_j\} = C_{Z_{j-1}}^j \cap D_{Z_{j-1}}^j$, for even j). Now suppose that in this round they have very little information about Z_{j-1} . Let us say, for example, that the distribution of $Z_{j-1} \mid E_{j-1}, \Pi_{j-1}$ is close to uniform. This certainly holds when $j = 2$, since $\mu(Z_1 \mid E_1, \Pi_1) = \mu(Z_1)$ is completely uniform (because the wrong pair of players speak first and the way we construct $\mathcal{D}_{\text{BMHPC}}$).
- Now suppose that despite this, somehow, the two speaking players nonetheless manage to learn a lot of information about Z_j . Then they have “almost solved” an *unknown* instance (an instance belonging to the other players, no less), out of the possible remaining instances of Set-Intersection. Because they have little information about Z_{j-1} , meaning Z_{j-1} is close to uniform, they have thus “almost solved” an unknown, nearly-uniformly-chosen instance.
- Then, intuitively, they must have “almost solved” this unknown instance of Set-Intersection without revealing a lot of information about it. This turns out to be impossible, as we will see in Section 4.4.

One difficulty in implementing this intuitive strategy is in finding the right measure of information that allows for one to carry through the entire argument. In [ACK19], *total variation distance from uniform* was used as a measure of how much the speaking players know about which Set-Intersection instance they are trying to solve. But TVD incurs the quadratic loss inherent in Pinsker’s inequality, leading to a lower-bound of $\frac{m^2}{r^2}$. The same quadratic loss appeared originally in Nisan and Wigderson’s lower-bounds for pointer chasing [NW93], and this led to a three-decade-long gap between known upper and lower-bounds for pointer chasing. This gap was finally closed by Amir Yehudayoff [Yeh20], using positive triangular discrimination. This suggested the possibility of using Yehudayoff’s approach to improve the lower-bound of [ACK19], and it is this plan that we realize here.

The following lemma states that no low-information protocol (in the sense of information cost) for BMHPC can reveal a lot of information (in the sense of Λ -distance-from-uniform) about a uniformly chosen SetInt instance at any layer j . The proof shows that any such protocol would give us a low-information protocol for ε -solving SetInt, which we will show is impossible in Section 4.4.

Lemma 4.8. *There is a constant $c > 0$ such that, for any protocol for $\text{BMHPC}_{m,r}$ running on input*

(A, B, C, D) sampled from $\mathcal{D}_{\text{BMHPC}}$, and for any $j \in [r]$, we have:

$$\begin{aligned} \mathbb{E}_{(\mathbf{E}_j, \Pi_j)} \mathbb{E}_{x \sim \mathcal{U}_X} [\Lambda(\mu(\mathbf{T}_x^j | \mathbf{E}_j, \Pi_j), \mu(\mathbf{T}_x^j))] &\leq c \cdot \frac{\mathbb{I}(\Pi; \mathbf{A}^j | \mathbf{A}^{<j}, \mathbf{B}) + \mathbb{I}(\Pi; \mathbf{B}^j | \mathbf{B}^{>j}, \mathbf{A})}{m^2} \\ \mathbb{E}_{(\mathbf{E}_j, \Pi_j)} \mathbb{E}_{y \sim \mathcal{U}_Y} [\Lambda(\mu(\mathbf{T}_y^j | \mathbf{E}_j, \Pi_j), \mu(\mathbf{T}_y^j))] &\leq c \cdot \frac{\mathbb{I}(\Pi; \mathbf{C}^j | \mathbf{C}^{<j}, \mathbf{D}) + \mathbb{I}(\Pi; \mathbf{D}^j | \mathbf{D}^{>j}, \mathbf{C})}{m^2} \end{aligned}$$

Proof. Take any given $j \in [r]$, and consider the following protocol for ε -solving SetInt on $\mathcal{D}_{\text{Set-Int}}$:

Protocol π_{SI} : The protocol for ε -solving Set-Int using a protocol π_{HPC} for $\text{BMHPC}_{m,r}$.

Input: An instance $(X, Y) \sim \mathcal{D}_{\text{Set-Int}}$ with $X, Y \subseteq \mathcal{Y}$.

1. **Sampling the instance.** Alice and Bob create an instance (A, B, C, D) of $\text{BMHPC}_{m,r}$ as follows:
 - (a) Using public coins, Alice and Bob sample an index $I \in [m]$ uniformly at random, and Alice sets $A_{x_I}^j = X$ and Bob sets $B_{x_I}^j = Y$ using their given inputs in Set-Int .
 - (b) Using public coins, Alice and Bob sample $A_{x_1}^j, \dots, A_{x_{I-1}}^j$ from the A-side marginal of $\mathcal{D}_{\text{Set-Int}}$, and they sample $B_{x_{I+1}}^j, \dots, B_{x_m}^j$ from the B-side marginal of $\mathcal{D}_{\text{Set-Int}}$.
 - (c) Using private coins, Alice samples $A_{x_r}^j$ for $r \in \{I+1, \dots, n\}$ so that $(A_{x_r}^j, B_{x_r}^j) \sim \mathcal{D}_{\text{Set-Int}}$. Similarly Bob samples $B_{x_\ell}^j$ for $\ell \in \{1, \dots, I-1\}$. This completes the construction of (A^j, B^j) .
 - (d) Using public coins, Alice and Bob sample $A^{<j}, B^{>j}, C$ and D from their respective marginals in $\mathcal{D}_{\text{BMHPC}}$ (this is possible by independence).
 - (e) Using private coins, Alice samples $A^{>j}$ conditioned on the publicly sampled $B^{>j}$, and Bob samples $B^{<j}$ conditioned on the publicly sampled $A^{<j}$.
2. The players now run the first j rounds of the protocol π_{BMHPC} on the instance (A, B, C, D) , by Alice playing P_A , Bob playing P_B , and both Alice and Bob simulating P_C and P_D with no communication (this is possible as both Alice and Bob know (C, D) entirely).

Let us write $\Pi_{\text{Set-Int}}$ to denote the messages of P_A and P_B , which were actually sent by Alice and Bob, and $\Pi_{\leq j}$ to denote the entire simulated transcript of π_{BMHPC} , including the messages of P_C and P_D (which Alice and Bob learned without communicating).

From a simple direct-sum argument, we get an upper-bound on the information cost of $\pi_{\text{Set-Int}}$:

Claim 4.9.

$$\text{IC}_{\mathcal{D}_{\text{Set-Int}}}(\pi_{\text{Set-Int}}) = \frac{\mathbb{I}(\Pi_{\leq j}; \mathbf{A}^j | \mathbf{A}^{<j}, \mathbf{B}) + \mathbb{I}(\Pi; \mathbf{B}^j | \mathbf{B}^{>j}, \mathbf{A})}{m}.$$

Proof. The internal information cost of $\pi_{\text{Set-Int}}$ is

$$\text{IC}_{\mathcal{D}_{\text{Set-Int}}}(\pi_{\text{Set-Int}}) := \mathbb{I}(X; \Pi_{\text{SI}} | Y, R, R_B) + \mathbb{I}(Y; \Pi_{\text{SI}} | X, R, R_A),$$

where R, R_A, R_B are the public, Alice's, and Bob's randomness. Let us bound the first term, as

the second term can be bounded in just the same way. We then derive:

$$\begin{aligned}
\mathbb{I}(\Pi_{\text{Set-Int}}; X | Y, R, R_B) &= \mathbb{I}(\Pi_{\leq j}; X | Y, I, A_{<I}^j, B_{>I}^j, A^{<j}, B^{>j}, C, D, B_{<I}^j, B^{<j}) \\
&= \mathbb{I}(\Pi_{\leq j}; A_I^j | I, A_{<I}^j, A^{<j}, B, C, D) \\
&= \sum_{i=1}^m \frac{1}{m} \mathbb{I}(\Pi_{\leq j}; A_i^j | I = i, A_{<i}^j, A^{<j}, B, C, D) \\
&= \sum_{i=1}^m \frac{1}{m} \mathbb{I}(\Pi_{\leq j}; A_i^j | A_{<i}^j, A^{<j}, B, C, D) \\
&= \frac{1}{m} \mathbb{I}(\Pi_{\leq j}; A^j | A^{<j}, B, C, D) \\
&= \frac{1}{m} \mathbb{I}(\Pi_{\leq j}; A^j | A^{<j}, B).
\end{aligned}$$

All equalities are by definition, except for the fourth which is because none of the remaining distributions depend on the choice of I , and the last, which is because C, D are independent of A^j , even when conditioned on $\Pi_{\leq j}, A^{<j}, B$. \square

On the other hand, we also get an ε -solver, for ε being exactly the Λ distance-from-uniform of a uniformly chosen coordinate in the j -th layer:

Claim 4.10. $\pi_{\text{Set-Int}}$ internally ε -solves Set-Intersection on $\mathcal{D}_{\text{Set-Int}}$ where:

$$\varepsilon \geq \mathbb{E}_{(E_j, \Pi_j)} \mathbb{E}_{x \sim \mathcal{U}_X} [\Lambda(\mu(\mathbb{T}_x^j | E_j, \Pi_j), \mu(\mathbb{T}_x^j))].$$

Proof. By Definition 4.3 and Observation 4.5, we have an ε -solver on Bob's side, for

$$\varepsilon = \mathbb{E}[\Lambda(\mu(\mathbb{T} | Y, \Pi_{\text{Set-Int}}, I, R, R_B), \mu(\mathbb{T} | Y, I, R, R_B))],$$

where $T = X \cap Y = A_I^j \cap B_I^j$, I and $R = A_{<I}^j, B_{>I}^j, A^{<j}, B^{>j}, C, D$ are the public randomness, and $R_B = B_{<I}^j, B^{<j}$ is Bob's private randomness. This is exactly equal to

$$\mathbb{E}[\Lambda(\mu(\mathbb{T} | Y, E_j, \Pi_j, I, R, R_B), \mu(\mathbb{T} | Y, I, R, R_B))],$$

because E_j, Π_j is a function of $\Pi_{\text{Set-Int}}, I, R, R_B$ (Bob knows both $A^{<j}, B^{<j}$ and C, D , so he also knows $Z_{<j}$, and $\Pi_{\leq j}$). In turn, this equals

$$\mathbb{E}_{E_j, \Pi_j, i \sim \mathcal{U}_{[m]}} \mathbb{E}[\Lambda(\mu(\mathbb{T}_{x_i}^j | E_j, \Pi_j, I = i, Y, R, R_B), \mu(\mathbb{T}_{x_i}^j | Y, I = i, R, R_B))]$$

Observe that none of the distributions above depend on the event $I = i$. So this quantity is equal to

$$\mathbb{E}_{E_j, \Pi_j, i \sim \mathcal{U}_{[m]}} \mathbb{E}[\Lambda(\mu(\mathbb{T}_{x_i}^j | E_j, \Pi_j, Y, R, R_B), \mu(\mathbb{T}_{x_i}^j | Y, R, R_B))]$$

Now, by Observation 4.4, this is greater or equal to

$$\mathbb{E}_{E_j, \Pi_j, i \sim \mathcal{U}_{[m]}} \mathbb{E}[\Lambda(\mu(\mathbb{T}_{x_i}^j | E_j, \Pi_j), \mu(\mathbb{T}_{x_i}^j))]. \quad \square$$

From Corollary 4.13 proven in the next section, it now follows:

$$\begin{aligned}
\frac{\mathbb{I}(\Pi_{\leq j}; A^j | A^{<j}, B) + \mathbb{I}(\Pi_{\leq j}; B^j | B^{>j}, A)}{m} &\geq c \cdot \varepsilon m \\
&\geq cm \cdot \mathbb{E}_{(E_j, \Pi_j)} \mathbb{E}_{x \sim \mathcal{U}_X} [\Lambda(\mu(\mathbb{T}_x^j | E_j, \Pi_j), \mu(\mathbb{T}_x^j))].
\end{aligned}$$

This concludes the proof of Lemma 4.8. \square

It is now possible to prove that there is no low-information protocol for solving BMHPC. The argument was roughly outlined above: if we assume by induction that the Λ distance-from-uniform is small for the answer at the previous layer, then we are essentially trying to solve a uniformly random instance at the current layer. And we just proved that this is not possible.

Lemma 4.11. *For the same constant $c > 0$ of the Lemma 4.8, and for any protocol for $\text{BMHPC}_{m,r}$ running on input (A, B, C, D) sampled from $\mathcal{D}_{\text{BMHPC}}$, the following statement holds for all $j \in [r]$.⁴*

$$\mathbb{E}_{(\mathbf{E}_j, \Pi_j)} [\Lambda(\mu(Z_j | \mathbf{E}_j, \Pi_j), \mu(Z_j))] \leq 6c \cdot \frac{\mathbb{I}(\Pi; \mathbf{A}^{\leq j}, \mathbf{C}^{\leq j} | \mathbf{B}, \mathbf{D}) + \mathbb{I}(\Pi; \mathbf{B}^{\leq j}, \mathbf{D}^{\leq j} | \mathbf{B}^{> j}, \mathbf{D}^{> j}, \mathbf{A}, \mathbf{C})}{m^2}.$$

This is proven by induction. The base case is easy to see: note that $\mu(Z_1 | \mathbf{E}_1, \Pi_1) = \mu(Z_1)$ as Z_1 is independent of $\mathbf{E}_1 = z_0$ which is fixed and Z_1 is independent of Π_1 as Π_1 is a function of (C, D) . We obtain case j from case $j - 1$ in two steps: we first show that if the protocol reveals a lot of information about the variable Z_j , then it must essentially be ε -solving a *uniformly random instance*. This is because $Z_j = T_{Z_{j-1}}$ and Z_{j-1} is, under the inductive case $j - 1$, close to uniform. We then appeal to the previous lemma.

Proof. The information—measured by Λ -distance to uniform—that the j -th round of the protocol reveals about $Z_j = T_{Z_{j-1}}$ is the information revealed about an instance sampled according to Z_{j-1} :

$$\begin{aligned} \mathbb{E}_{(\mathbf{E}_j, \Pi_j)} [\Lambda(\mu(Z_j | \mathbf{E}_j, \Pi_j), \mu(Z_j))] &= \mathbb{E}_{(\mathbf{E}_j, \Pi_j)} [\Lambda(\mu(Z_j | \mathbf{E}_j), \mu(Z_j))] \\ &= \mathbb{E}_{(\mathbf{Z}_{< j}, \Pi_{< j})} [\Lambda(\mu(Z_j | \mathbf{Z}_{< j}, \Pi_{< j}), \mu(Z_j))] \\ &\quad \text{(by definition of } \mathbf{E}_j := (\mathbf{Z}_{< j}, \Pi_{< j}), \text{ and since } Z_j \text{ and } \Pi_j \text{ are independent given } \mathbf{E}_j.) \\ &= \mathbb{E}_{(\mathbf{Z}_{< j}, \Pi_{< j})} [\Lambda(\mu(T_{Z_{j-1}}^j | \mathbf{Z}_{< j-1}, Z_{j-1}, \Pi_{< j}), \mu(Z_j))] \\ &\quad \text{(by definition, the pointer } Z_j = T_{Z_{j-1}}) \\ &= \mathbb{E}_{(\mathbf{Z}_{< j-1}, \Pi_{< j})} \mathbb{E}_{z \sim Z_{j-1} | (\mathbf{Z}_{< j-1}, \Pi_{< j})} [\Lambda(\mu(T_z^j | \mathbf{Z}_{< j-1}, \Pi_{< j}), \mu(Z_j))]. \end{aligned}$$

We removed the conditioning on $Z_{j-1} = z$ in the first distribution because, conditioned on knowing $\mathbf{Z}_{< j-1}, \Pi_{< j}$, for any fixed value of z the value of T_z is independent of the value of Z_{j-1} :

- If $j - 1$ is odd, T_z is a function of (C, D) and Z_{j-1} is a function of (A, B) .
- If $j - 1$ is even, T_z is a function of (A, B) and Z_{j-1} is a function of (C, D) .
- And, furthermore, (A, B) and (B, D) are independent given $\mathbf{Z}_{< j-1}, \Pi_{< j}$.

Lemma 4.8 says that if the protocol were to reveal information about the solution T_z of a truly uniform instance z , then this would give us a protocol for ε -solving set disjointness. But, by induction, we know that the chosen instance $z \sim Z_{j-1}$ is close to uniform. It should then follow from Proposition 3.9 that if the protocol reveals some information about this almost uniform instance, it must also reveal information about a truly uniform instance. Let us now make this precise.

Without loss of generality suppose that $j - 1$ is odd and hence $z \in \mathcal{Y}$. Then we can upper bound the last expression above by:⁵

⁴Intuitively, the statement says that, if π_{BMHPC} communicates little, then the distribution of Z_j , conditioned on the information available at the end of round j , is close to uniform.

⁵In the first inequality it should be understood how Λ is playing two different roles. On the one hand it is being used as an information-theoretic quantity (the distance to uniform), and on the other it is being used in a capacity similar to how total variation distance appears in the obvious upper-bound $\mathbb{E}_\mu[f(x)] \leq \mathbb{E}_\nu[f(x)] + \|\mu - \nu\|_1 \cdot \max f(x)$.

$$\begin{aligned}
& \mathbb{E}_{(\mathbf{E}_j, \Pi_j)} \left[\Lambda(\mu(\mathbf{Z}_j \mid \mathbf{E}_j, \Pi_j), \mu(\mathbf{Z}_j)) \right] \\
& \leq \mathbb{E}_{(\mathbf{Z}_{<j-1}, \Pi_{<j})} \left[6 \cdot \mathbb{E}_{(z \sim \mathcal{U}_y)} \left[\Lambda(\mu(\mathbb{T}_z^j \mid \mathbf{Z}_{<j-1}, \Pi_{<j}), \mu(\mathbf{Z}_j)) \right] \right] \\
& \quad + \mathbb{E}_{(\mathbf{Z}_{<j-1}, \Pi_{<j})} \left[\Lambda(\mu(\mathbf{Z}_{j-1} \mid \mathbf{E}_{j-1}, \Pi_{j-1}), \mathcal{U}_y) \right] \\
& \hspace{15em} \text{(by Proposition 3.9 and linearity of expectation)} \\
& = 6 \cdot \mathbb{E}_{(\mathbf{Z}_{<j-1}, \Pi_{<j})} \left[\mathbb{E}_{(z \sim \mathcal{U}_y)} \left[\Lambda(\mu(\mathbb{T}_z^j \mid \mathbf{Z}_{<j-1}, \Pi_{<j}), \mu(\mathbf{Z}_j)) \right] \right] \\
& \quad + \mathbb{E}_{(\mathbf{Z}_{<j-1}, \Pi_{<j})} \left[\Lambda(\mu(\mathbf{Z}_{j-1} \mid \mathbf{E}_{j-1}, \Pi_{j-1}), \mu(\mathbf{Z}_{j-1})) \right] \\
& \hspace{15em} \text{(by definition } z_{j-1} \in \mathcal{Y} \text{ and } \mu(\mathbf{Z}_{j-1}) = \mathcal{U}_y.) \\
& \leq \left[6 \cdot c \cdot \underbrace{\frac{\mathbb{I}(\Pi; \mathbf{A}^j \mid \mathbf{A}^{<j}, \mathbf{B}) + \mathbb{I}(\Pi; \mathbf{B}^j \mid \mathbf{B}^{>j}, \mathbf{A})}{m^2}}_{\text{Lemma 4.8}} \right. \\
& \quad \left. + 6c \cdot \underbrace{\frac{\mathbb{I}(\Pi; \mathbf{A}^{\leq j-1}, \mathbf{C}^{\leq j-1} \mid \mathbf{B}, \mathbf{D}) + \mathbb{I}(\Pi; \mathbf{B}^{\leq j-1}, \mathbf{D}^{\leq j-1} \mid \mathbf{B}^{>j-1}, \mathbf{D}^{>j-1}, \mathbf{A}, \mathbf{C})}{m^2}}_{\text{induction hypothesis (case } j-1)} \right] \\
& = \left[6c \cdot \frac{\mathbb{I}(\Pi; \mathbf{A}^j \mid \mathbf{A}^{<j}, \mathbf{C}^{<j}, \mathbf{B}, \mathbf{D}) + \mathbb{I}(\Pi; \mathbf{B}^j \mid \mathbf{B}^{>j}, \mathbf{D}^{>j}, \mathbf{A}, \mathbf{C})}{m^2} \right. \\
& \quad \left. + 6c \cdot \frac{\mathbb{I}(\Pi; \mathbf{A}^{\leq j-1}, \mathbf{C}^{\leq j-1} \mid \mathbf{B}, \mathbf{D}) + \mathbb{I}(\Pi; \mathbf{B}^{\leq j-1}, \mathbf{D}^{\leq j-1} \mid \mathbf{B}^{>j-1}, \mathbf{D}^{>j-1}, \mathbf{A}, \mathbf{C})}{m^2} \right] \\
& \leq \left[6c \cdot \frac{\mathbb{I}(\Pi; \mathbf{A}^j, \mathbf{C}^j \mid \mathbf{A}^{<j}, \mathbf{C}^{<j}, \mathbf{B}, \mathbf{D}) + \mathbb{I}(\Pi; \mathbf{B}^j, \mathbf{D}^j \mid \mathbf{B}^{>j}, \mathbf{D}^{>j}, \mathbf{A}, \mathbf{C})}{m^2} \right. \\
& \quad \left. + 6c \cdot \frac{\mathbb{I}(\Pi; \mathbf{A}^{\leq j-1}, \mathbf{C}^{\leq j-1} \mid \mathbf{B}, \mathbf{D}) + \mathbb{I}(\Pi; \mathbf{B}^{\leq j-1}, \mathbf{D}^{\leq j-1} \mid \mathbf{B}^{>j-1}, \mathbf{D}^{>j-1}, \mathbf{A}, \mathbf{C})}{m^2} \right] \\
& = 6c \cdot \frac{\mathbb{I}(\Pi; \mathbf{A}^{\leq j}, \mathbf{C}^{\leq j} \mid \mathbf{B}, \mathbf{D}) + \mathbb{I}(\Pi; \mathbf{B}^{\leq j}, \mathbf{D}^{\leq j} \mid \mathbf{B}^{>j}, \mathbf{D}^{>j}, \mathbf{A}, \mathbf{C})}{m^2},
\end{aligned}$$

where the last inequality follows from the data processing inequality (Fact E.2 Item 8). This concludes the proof. \square

4.4 ε -Solvers for Set-Int Give Exact Solvers

We now show a lower-bound against protocols trying to ε -solve Set-Intersection, by reducing from exactly solving Set-Intersection:

Theorem 4.12. *For any constant $\gamma \in (0, 1)$, there exists a constant $c \geq 1$ such that, given a protocol $\pi_{\text{Set-Int}}$ which internally ε -solves Set-Intersection (in Λ distance) on $\mathcal{D}_{\text{Set-Int}}$ with $\varepsilon \geq \frac{8}{m}$, we may obtain a protocol π that exactly solves Set-Intersection on $\mathcal{D}_{\text{Set-Int}}$, such that $\text{IC}_{\mathcal{D}_{\text{Set-Int}}}(\pi) \leq \frac{c}{\varepsilon} \cdot \text{IC}_{\mathcal{D}_{\text{Set-Int}}}(\pi_{\text{Set-Int}}) + \gamma m$.*

From the known fact (Proposition 3.2) that Set-Intersection has information complexity $\Omega(m)$ on $\mathcal{D}_{\text{Set-Int}}$ we get the following:

Corollary 4.13. *There exists a constant $c > 0$ such that any protocol $\pi_{\text{Set-Int}}$ that internally (Λ, ε) -solves SetInt_m on inputs from the distribution $\mathcal{D}_{\text{Set-Int}}$, with $\varepsilon \geq 8/m$, has $\text{IC}_{\mathcal{D}_{\text{Set-Int}}}(\pi_{\text{Set-Int}}) \geq c \cdot \varepsilon m$.*

An analogue of Theorem 4.12 was proven in [AR20], where ε -solving was with respect to total variation distance instead of triangular discrimination. It was then shown that any protocol for ε -solving Set-Intersection in this TVD sense gives a protocol for Set-Intersection with a $O(1/\varepsilon^2)$ blowup in information cost. Theorem 4.12, instead, gives a blowup of $O(1/\varepsilon)$. So our assumption is stronger, but our conclusion is also stronger.

Proof of Theorem 4.12. We begin by recalling the notation we use for the Set-Intersection problem: Alice and Bob’s input sets are denoted by X and Y respectively, and their corresponding random variables by \mathbf{X} and \mathbf{Y} . The unique element in the intersection $X \cap Y$ is denoted by e^* , and its random variable is \mathbf{e}^* . Throughout this proof, for a permutation σ and a set S , $\sigma(S)$ denotes the set $\{\sigma(s) \mid s \in S\}$.

Without loss of generality, we may assume that we have a protocol $\pi_{\text{Set-Int}}$ that internally ε -solves from Alice’s side Set-Intersection on inputs distributed according to $\mathcal{D}_{\text{Set-Int}}$, that is,

$$\Lambda = \mathbb{E}_{\mathbf{X}, \Pi} [\Lambda(\mu(\mathbf{e}^* \mid \Pi, \mathbf{X}), \mu(\mathbf{e}^*, \mathbf{X}))] \geq \varepsilon,$$

where $\varepsilon \geq 8/m$. We will use $\pi_{\text{Set-Int}}$ to design a protocol π which solves Set-Intersection on $\mathcal{D}_{\text{Set-Int}}$.

For now, suppose that Alice and Bob proceed as follows: they sample a uniformly random permutation Γ of $[m]$ using public randomness, and run the ε -solving protocol $\pi_{\text{Set-Int}}$ on $(\Gamma(X), \Gamma(Y))$, obtaining a transcript Π . Alice now knows the induced distribution of the intersection point $\mu(\Gamma(e^*) \mid \Pi = \Pi, \Gamma(X) = \Gamma(X))$, conditioned on the transcript she has seen, and Bob knows the analogous distribution with his input fixed. Without the conditioning on the transcript, we know by symmetry of $\mathcal{D}_{\text{Set-Int}}$ that $\mu(\Gamma(e^*) \mid \Gamma(X) = \Gamma(X))$ is uniform over $\Gamma(X)$. In fact, we have the following observation about the distribution of inputs generated by applying Γ .

Observation 4.14. *For any fixed X and Y such that $|X| = |Y| = m/4$, and $|X \cap Y| = 1$, and a uniformly random permutation Γ , the instance $(\Gamma(X), \Gamma(Y))$ is distributed according to $\mathcal{D}_{\text{Set-Int}}$.*

To see this, consider the fixed values $X = \{1, \dots, m/4\}$ and $Y = \{m/4, \dots, m/2 - 1\}$. Because Γ is a uniformly random permutation, it maps $m/4$ to a uniformly random element of $[m]$, and the rest of X and Y to uniformly random subsets of size $m/4 - 1$. By symmetry, this argument applies to any fixed X and Y of size $m/4$ intersecting in exactly one element.

4.4.1 A single round of π

We start by describing a single round of the protocol π . On the input (X, Y) :

1. Alice and Bob publicly sample a random permutation Γ of $[m]$, and apply it to X and Y to obtain $\Gamma(X)$ and $\Gamma(Y)$ respectively.
2. They run $\pi_{\text{Set-Int}}$ on $\Gamma(X)$ and $\Gamma(Y)$ to obtain a transcript Π . By doing so, Alice learns a distribution q_1^Π, \dots, q_m^Π , where

$$q_i^\Pi = \Pr[\Gamma(e^*) = i \mid \Pi = \Pi, \Gamma(X) = \Gamma(X)].$$

3. Alice uses q_i^Π to assign “scores” to each element e of $[m]$, which reflect the likelihood that $\{e\}$ is the intersection of X and Y .

This strategy follows the general idea of [AR20], but where they assigned the score 1 to all e such that $q_{\Gamma(e)}^\Pi$ is in the largest-probability half of q_1^Π, \dots, q_m^Π (and this works for ε -solving under TVD), we assign scores in a smoother fashion. Let $i = \Gamma(e)$ and $n = m/4$ for brevity. Then if $q_i^\Pi \leq 1/n$, we give e a score of 0. Otherwise, its score is $(q_i^\Pi - 1/n)/(q_i^\Pi + 1/n)$. This choice of the “scoring function” may seem odd at this juncture, so we offer two comments about it:

- Note that this is equal to $1 - (2/n)/(q_i^\Pi + 1/n)$, which is an increasing function of q_i^Π , and hence passes a basic sanity test (i.e. if $\pi_{\text{Set-Int}}$ says an element is more likely to be $\Gamma(e^*)$, we believe it).
- The scoring function was chosen to make the expected score of e^* larger than the expected score of any non- e^* element by at least Λ , and the variance of every element's score turned out to be small.

We package the properties of this scoring function into a few claims below. Throughout these claims, we will use the shorthand notation $\mathbf{A} \mid B$ to mean $\mathbf{A} \mid \mathbf{B} = B$, where \mathbf{A} and \mathbf{B} are random variables, and B is some fixed value that \mathbf{B} can take.

Claim 4.15. *For any non- e^* element $e \in [m]$,*

$$\mathbb{E}_{\Gamma}[\text{Score}(e^*) - \text{Score}(e)] \geq \Lambda/2.$$

Proof. The proof is in two parts; first we bound $\text{Score}(e^*)$ under some appropriate conditioning, and then $\text{Score}(e)$ for non- e^* elements.

Fix any (X, Y) with $|X| = |Y| = n$ and $|X \cap Y| = 1$. Consider a fixed choice of $\Gamma(X)$ and the transcript Π , and hence a distribution q^Π . Let P denote the set of indices where $q_i^\Pi > 1/n$ (i.e. those that lead to positive scores). Note that $P \subseteq \Gamma(X)$; because we condition on $\Gamma(X)$ (and more) to obtain q^Π . By definition, the probability that e^* is mapped to i is q_i , and hence:

$$\mathbb{E}_{\Gamma|\Gamma(X), \Pi}[\text{Score}(e^*)] = \sum_{i \in P} q_i^\Pi \cdot \frac{q_i^\Pi - 1/n}{q_i^\Pi + 1/n}.$$

On the other hand, fixing both $\Gamma(X)$, $\Gamma(Y)$ (and hence also $\Gamma(e^*)$) and Π , fixes the distribution q^Π , but leaves completely free the map $\Gamma : X \setminus \{e^*\} \rightarrow \Gamma(X) \setminus \{\Gamma(e^*)\}$. So we find that:

$\Gamma(e)$ is uniformly random over $\Gamma(X) \setminus \{\Gamma(e^*)\}$ for any non- e^* element $e \in X$.

This means that for any $i \in [m]$,

$$\Pr_{\Gamma|\Gamma(X), \Gamma(Y), \Pi}[\Gamma(e) = i] \leq \frac{1}{n-1}.$$

Hence we can compute the expected score of e as:

$$\begin{aligned} \mathbb{E}_{\Gamma|\Gamma(X), \Gamma(Y), \Pi}[\text{Score}(e)] &= \sum_{i \in P} \Pr[\Gamma(e) = i] \cdot \frac{q_i^\Pi - 1/n}{q_i^\Pi + 1/n} \leq \sum_{i \in P} \frac{1}{n-1} \cdot \frac{q_i^\Pi - 1/n}{q_i^\Pi + 1/n} \\ &= \sum_{i \in P} \left(\frac{1}{n} + \frac{1}{n(n-1)} \right) \cdot \frac{q_i^\Pi - 1/n}{q_i^\Pi + 1/n} \leq \frac{1}{n} + \sum_{i \in P} \frac{1}{n} \cdot \frac{q_i^\Pi - 1/n}{q_i^\Pi + 1/n}, \end{aligned}$$

where the last inequality follows because $|P| \leq n-1$. And now taking expectation over $\Gamma(X)$ and Π :

$$\begin{aligned} \mathbb{E}_{\Gamma(X), \Pi} \mathbb{E}_{\Gamma|\Pi, \Gamma(X)}[\text{Score}(e^*) - \text{Score}(e)] &= \mathbb{E}_{\Gamma(X), \Pi} \left[\mathbb{E}_{\Gamma|\Pi, \Gamma(X)}[\text{Score}(e^*)] - \mathbb{E}_{\Gamma(Y)|\Pi, \Gamma(X)} \mathbb{E}_{\Gamma|\Gamma(X), \Gamma(Y)}[\text{Score}(e)] \right] \\ &\geq \mathbb{E}_{\Gamma(X), \Pi} \left[\sum_{i \in P} \frac{(q_i^\Pi - 1/n)^2}{q_i^\Pi + 1/n} - 1/n \right] \\ &= \mathbb{E}_{\Gamma(X), \Pi} [\Lambda(q^\Pi, \mathcal{U}_{\Gamma(X)})] - 1/n = \Lambda - 1/n \geq \Lambda/2. \end{aligned}$$

where the last inequality is because $\Lambda \geq \varepsilon \geq 8/m = 2/n$.

□

Claim 4.16. *The variance of $\text{Score}(e^*)$ is at most Λ .*

Proof. Recall that $\text{Var}[X] \leq \mathbb{E}[X^2]$ for any random variable X . As before, we will bound $\mathbb{E}[\text{Score}(e^*)]$ by conditioning on fixed choices of $\Gamma(X)$ and the transcript Π , which gives Alice the distribution q^Π . Also as before, let P denote the set of indices i such that $q_i \geq 1/n$.

$$\begin{aligned} \mathbb{E}_{\Gamma(X), \Pi} [\text{Score}(e^*)^2] &= \sum_{i \in P} q_i^\Pi \cdot \left(\frac{q_i^\Pi - 1/n}{q_i^\Pi + 1/n} \right)^2 \\ &= \sum_{i \in P} \frac{q_i^\Pi}{q_i^\Pi + 1/n} \cdot \frac{(q_i^\Pi - 1/n)^2}{q_i^\Pi + 1/n} \\ &\leq \Lambda(q^\Pi, \mathcal{U}_{\Gamma(X)}). \end{aligned}$$

And taking expectation over $\Gamma(X)$ and Π :

$$\mathbb{E}_{\Gamma(X), \Pi} \mathbb{E}_{\Gamma(X), \Pi} [\text{Score}(e^*)^2] \leq \mathbb{E}_{\Gamma(X), \Pi} [\Lambda(q^\Pi, \mathcal{U}_{\Gamma(X)})] = \Lambda.$$

□

Claim 4.17. *For any $e (\neq e^*) \in X$, the variance of $\text{Score}(e)$ is at most 2Λ .*

Proof. Again, because $\text{Var}[X] \leq \mathbb{E}[X^2]$ for any random variable X , and conditioning on fixed choices of $\Gamma(X), \Gamma(Y)$ and Π , $\Gamma(e)$ for $e \in X \setminus \{e^*\}$ is uniformly random over $\Gamma(X \setminus \{e^*\})$:

$$\begin{aligned} \mathbb{E}_{\Gamma(X), \Gamma(Y), \Pi} [\text{Score}(e)^2] &= \sum_{i \in P} \frac{1}{n-1} \cdot \left(\frac{q_i^\Pi - 1/n}{q_i^\Pi + 1/n} \right)^2 \\ &\leq \sum_{i \in P} \frac{1}{n-1} \cdot \frac{(q_i^\Pi - 1/n)^2}{q_i^\Pi + 1/n} \cdot \frac{1}{1/n} \\ &= \Lambda(q^\Pi, \mathcal{U}_{\Gamma(X)}) \cdot \left(1 + \frac{1}{n-1} \right) \leq 2\Lambda(q^\Pi, \mathcal{U}_{\Gamma(X)}), \end{aligned}$$

where the first inequality holds because $q_i^\Pi \geq 0$. And taking expectation over $\Gamma(X), \Gamma(Y)$ and Π :

$$\mathbb{E}_{\Gamma(X), \Pi} \left[\mathbb{E}_{\Gamma(Y), \Gamma(X), \Pi} \left[\mathbb{E}_{\Gamma(X), \Gamma(Y), \Pi} [\text{Score}(e)^2] \right] \right] \leq \mathbb{E}_{\Gamma(X), \Pi} [2\Lambda(q^\Pi, \mathcal{U}_{\Gamma(X)})] = 2\Lambda.$$

□

4.4.2 The actual protocol

We are ready to describe the protocol π . Let $\gamma \in (0, 1)$ be any constant. We will run $k = 1600/(\varepsilon\gamma^2)$ (independent) rounds of the protocol in Section 4.4.1, and for each element $e \in X$, Alice will add up its scores in each round to obtain the total score $\text{TScore}(e)$. Claim 4.15 tells us that we should

expect the total score for e^* to be higher than the total score of an element $e \neq e^*$. We then choose the threshold

$$\tau = \left(\mathbb{E}[\text{TScore}(e^*)] + \mathbb{E}[\text{TScore}(e)] \right) / 2,$$

to be exactly in the middle of these two expected values.

Alice will then send to Bob all elements in X which have TScore at least τ ; let us call this set S . Bob will then compute the intersection $S \cap Y$, and report the unique element that is (hopefully) present there as the answer.

To complete the reduction, we need to show that:

- The total score of the target element $\text{TScore}(e^*)$ is at least τ . This will ensure that $e^* \in S$, which means that π is correct.
- The number of elements Alice sends is *small*. This is required to control the information cost of π .

We will get both of these properties only with some (constant) high probability; in particular, if S is too large, Alice will just report failure instead of communicating S .

Claim 4.18. $\text{TScore}(e^*) \leq \tau$ with probability at most $1/100$.

Proof. Using Chebyshev's inequality on the total score of e^* , we have:

$$\begin{aligned} & \Pr \left[\left| \text{TScore}(e^*) - \mathbb{E}[\text{TScore}(e^*)] \right| > 1/2 \cdot \mathbb{E}[\text{TScore}(e^*) - \text{TScore}(e)] \right] \\ & \leq \frac{\text{Var}[\text{TScore}(e^*)]}{(1/2 \cdot \mathbb{E}[\text{TScore}(e^*) - \text{TScore}(e)])^2} = \frac{k \cdot \text{Var}[\text{Score}(e^*)]}{k^2/4 \cdot \mathbb{E}[\text{Score}(e^*) - \text{Score}(e)]^2} \\ & \leq \frac{4\Lambda}{k \cdot (\Lambda/2)^2} \leq 16/k\varepsilon = \gamma^2/100, \end{aligned}$$

where the second inequality follows from Claims 4.15 and 4.16. Hence the probability that $\text{TScore}(e^*)$ is less than τ is at most $1/100$. \square

Claim 4.19. For any non- e^* element $e \in X$, $\text{TScore}(e) \geq \tau$ with probability at most $\gamma^2/50$.

Proof. Using Chebyshev on the total score of $e \neq e^*$, we have:

$$\begin{aligned} & \Pr \left[\left| \text{TScore}(e) - \mathbb{E}[\text{TScore}(e)] \right| > 1/2 \cdot \mathbb{E}[\text{TScore}(e^*) - \text{TScore}(e)] \right] \\ & \leq \frac{\text{Var}[\text{TScore}(e)]}{(1/2 \cdot \mathbb{E}[\text{TScore}(e^*) - \text{TScore}(e)])^2} = \frac{k \cdot \text{Var}[\text{Score}(e)]}{k^2/4 \cdot \mathbb{E}[\text{Score}(e^*) - \text{Score}(e)]^2} \\ & \leq \frac{4 \cdot 2\Lambda}{k \cdot (\Lambda/2)^2} \leq 32/k\varepsilon = \gamma^2/50, \end{aligned}$$

where the second inequality follows from Claims 4.15 and 4.17. \square

This means that the expected size of $S \setminus \{e^*\}$ is at most $\gamma^2 m / 50$, and hence by Markov's this number is $> \gamma^2 m / 10$ with probability $\leq 1/5$. If the number of elements above the threshold exceeds $\gamma^2 m / 10 + 1$, then the protocol π fails.

And now we have everything we need to bound the information cost of π . Note that this part of the argument is exactly as in [AR20]. By the chain rule of mutual information, the information cost of π on $\mathcal{D}_{\text{Set-Int}}$ can be broken down into three components:

- The mutual information $\mathbb{I}(\Gamma_1, \dots, \Gamma_k, R_1, \dots, R_k; \mathsf{X} | \mathsf{Y})$ and the symmetric term with X and Y exchanging roles, where Γ_i denotes the random permutations used to scramble the input in the i -th round of π , and R_i denotes the randomness of the i -th run of $\pi_{\text{Set-Int}}$. These are both 0, because the permutations and the randomness are chosen independently of the inputs X and Y .
- The mutual information $\mathbb{I}(\Pi_1, \dots, \Pi_k; \mathsf{X} | \mathsf{Y}, \Sigma, \mathsf{R})$ (and the symmetric term with X and Y swapped), where Π_1, \dots, Π_k denote the transcripts of the k runs of $\pi_{\text{Set-Int}}$, $\Sigma = \Gamma_1, \dots, \Gamma_k$, and $\mathsf{R} = R_1, \dots, R_k$. By the chain rule of mutual information, we have:

$$\mathbb{I}(\Pi_1, \dots, \Pi_k; \mathsf{X} | \mathsf{Y}, \Sigma, \mathsf{R}) \leq \sum_{i=1}^k \mathbb{I}(\Pi_i; \mathsf{X} | \mathsf{Y}, \Sigma, \mathsf{R}, \Pi_{<i}).$$

Observe that conditioning on X , Y , Γ_i , and R_i fixes Π_i , and hence makes it independent of $\Pi_{<i}$, $\Gamma_{<i}$, and $R_{<i}$. Applying Proposition E.4, we get that the i -th term of the sum above is upper bounded by $\mathbb{I}(\Pi_i; \mathsf{X} | \mathsf{Y}, \Gamma_i, R_i)$. But now (once again) Π_i is fixed after conditioning on $\Gamma_i(\mathsf{X})$, $\Gamma_i(\mathsf{Y})$, and R_i , and hence independent of the remaining parts of Γ_i and X and Y . So by Proposition E.4, each term in the sum is bounded above by $\mathbb{I}(\Pi_i; \Gamma_i(\mathsf{X}) | \Gamma(\mathsf{Y}), R_i)$. Repeating this entire argument for the symmetric term tells us that:

$$\mathbb{I}(\Pi_1, \dots, \Pi_k; \mathsf{X} | \mathsf{Y}, \Sigma, \mathsf{R}) + \mathbb{I}(\Pi_1, \dots, \Pi_k; \mathsf{Y} | \mathsf{X}, \Sigma, \mathsf{R}) \leq \sum_{i=1}^k \mathbb{I}(\Pi_i; \Gamma_i(\mathsf{X}) | \Gamma(\mathsf{Y}), R_i) + \mathbb{I}(\Pi_i; \Gamma_i(\mathsf{Y}) | \Gamma(\mathsf{X}), R_i),$$

which is exactly $k \cdot \text{IC}_{\mathcal{D}_{\text{Set-Int}}}^{\text{int}}(\pi_{\text{Set-Int}})$.

- The mutual information between the final set S Alice sends and her input. This is trivially upper bounded by $\mathbb{H}(\mathsf{S})$, which (since S is a set of size at most $\gamma^2 \cdot m/10$) is upper bounded by $H_2(\gamma^2/10) \cdot m$. Since $H_2(p) \leq 2\sqrt{p \cdot (1-p)} \leq 2\sqrt{p}$ (by Fact E.1), this is at most γm .

So letting $c = \frac{1600}{\gamma^2}$, we get that $\text{IC}_{\mathcal{D}_{\text{Set-Int}}}^{\text{int}}(\pi) \leq \frac{c}{\varepsilon} \text{IC}_{\mathcal{D}_{\text{Set-Int}}}^{\text{int}}(\pi_{\text{Set-Int}}) + \gamma m$. \square

Remark 4.20. The protocol π actually works in the worst case, that is, it needs no assumptions about X and Y other than $|X| = |Y| = m/4$, and that $|X \cap Y| = 1$. But of course without a distribution on its inputs we cannot talk about its information cost.

4.5 Short Protocols for BHPC Give Low-Information ε -Solvers for Set-Int

We also wish to prove a tight lower bound for $\text{BHPC}_{m,r}$. Note that this lower-bound is not necessary to derive our lower-bounds for k -cores and degeneracy, so this section may be skipped for that purpose. The lower-bound ultimately follows from the following lemma, which is analogous to Lemma 4.11.

Lemma 4.21. *There is a constant $c > 0$ such that the following statement holds for all $j \in [r]$:⁶*

$$\text{Hypothesis}_j : \quad \mathbb{E}_{(\mathbf{E}_j, \Pi_j)} [\Lambda(\mu(\mathbf{Z}_j | \mathbf{E}_j, \Pi_j), \mu(\mathbf{Z}_j))] \leq j \cdot c \cdot \left(\frac{CC(\pi_{\text{BHPC}}) + r \log m}{m^2} + \frac{r}{m} \right).$$

⁶Intuitively, the statement says that, if π_{BHPC} communicates little, then the distribution of \mathbf{Z}_j , conditioned on the information available at the end of round j , is close to uniform.

One can already see that the statement is more complicated. This is owed to the possibility of the pointers pointing either to some of the (few) instances about which the protocol has revealed information, and the possibility of the pointers looping. These two obstacles raise technical difficulties, which are overcome in two ways: the number of jumps r is assumed to be smaller than \sqrt{m} , so looping is unlikely, and there are only $O(m/r)$ instances about which the protocol could have revealed significant information, hence when hiding an instance of set-intersection in a random position, as we did before, it is unlikely we will hit such an instance.

As before, this is proven by induction. The base case **Hypothesis₁** is easy to see: note that $\mu(Z_1 \mid E_1, \Pi_1) = \mu(Z_1)$ as Z_1 is independent of $E_1 = z_0$ which is fixed and Z_1 is independent of Π_1 as Π_1 is a function of (C, D) . We obtain **Hypothesis_j** from **Hypothesis_{j-1}** in two steps: we first show that if the protocol reveals a lot of information about the variable Z_j , then it must essentially be “almost-solving” a *uniformly random instance*. This is because $Z_j = T_{Z_{j-1}}$ and Z_{j-1} is, under **Hypothesis_{j-1}**, close to uniform. We then show that this is impossible for a short protocol to do, namely:

Lemma 4.22. *There is a constant $c' > 0$ such that for any $j \in [r]$, we have:*

$$\begin{aligned} \mathbb{E}_{(E_j, \Pi_j)} \mathbb{E}_{x \sim \mathcal{U}_x} [\Lambda(\mu(T_x \mid E_j, \Pi_j), \mu(T_x))] &\leq c' \cdot \left(\frac{CC(\pi_{\text{BHPC}}) + r \log m}{m^2} + \frac{j}{m} \right) \\ \mathbb{E}_{(E_j, \Pi_j)} \mathbb{E}_{y \sim \mathcal{U}_y} [\Lambda(\mu(T_y \mid E_j, \Pi_j), \mu(T_y))] &\leq c' \cdot \left(\frac{CC(\pi_{\text{BHPC}}) + r \log m}{m^2} + \frac{j}{m} \right). \end{aligned}$$

We state the proof of Lemma 4.22 shortly. Before that, we show how Lemma 4.22 lets us complete the induction in order to prove Lemma 4.21. This also follows very closely to the analogous proof of [ACK19] where they showed it for total variation distance.

Proof of Lemma 4.21. The information—measured by Λ -distance to uniform—that the j -th round of the protocol reveals about $Z_j = T_{Z_{j-1}}$ is the information revealed about an instance sampled according to Z_{j-1} :

$$\begin{aligned} \mathbb{E}_{(E_j, \Pi_j)} \left[\Lambda(\mu(Z_j \mid E_j, \Pi_j), \mu(Z_j)) \right] &= \mathbb{E}_{(E_j, \Pi_j)} \left[\Lambda(\mu(Z_j \mid E_j), \mu(Z_j)) \right] \\ &= \mathbb{E}_{(Z^{<j}, \Pi^{<j})} \left[\Lambda(\mu(Z_j \mid Z^{<j}, \Pi^{<j}), \mu(Z_j)) \right] \\ &\quad \text{(by definition of } E_j := (Z^{<j}, \Pi^{<j}), \text{ and since } Z_j \text{ and } \Pi_j \text{ are independent given } E_j.) \\ &= \mathbb{E}_{(Z^{<j}, \Pi^{<j})} \left[\Lambda(\mu(T_{Z_{j-1}} \mid Z^{<j-1}, Z_{j-1}, \Pi^{<j}), \mu(Z_j)) \right] \\ &\quad \text{(by definition, the pointer } Z_j = T_{Z_{j-1}}) \\ &= \mathbb{E}_{(Z^{<j-1}, \Pi^{<j})} \mathbb{E}_{z \sim Z_{j-1} \mid (Z^{<j-1}, \Pi^{<j})} \left[\Lambda(\mu(T_z \mid Z^{<j-1}, \Pi^{<j}), \mu(Z_j)) \right]. \end{aligned}$$

We removed the conditioning on Z_{j-1} in the first distribution because, conditioned on knowing $Z^{<j-1}, \Pi^{<j}$, for any fixed value of z the value of T_z is independent of the value of Z_{j-1} :

- If $j - 1$ is odd, T_z is a function of (C, D) and Z_{j-1} is a function of (A, B) .
- If $j - 1$ is even, T_z is a function of (A, B) and Z_{j-1} is a function of (C, D) .
- And, furthermore, (A, B) and (B, D) are independent given $Z^{<j-1}, \Pi^{<j}$.

Lemma 4.22 says that if the protocol were to reveal information about the solution T_z of a truly uniform instance z , then this would give us a protocol for ε -solving set disjointness. But, by

induction, we know that the chosen instance $z \sim Z_{j-1}$ is close to uniform. It should then follow from Proposition 3.9 that if the protocol reveals some information about this almost uniform instance, it must also reveal information about a truly uniform instance. Let us now make this precise.

Without loss of generality suppose that $j - 1$ is odd and hence $z \in \mathcal{Y}$. Then we can upper bound the last expression above by:

$$\begin{aligned}
& \mathbb{E}_{(\mathbf{E}_j, \Pi_j)} \left[\Lambda(\mu(Z_j | \mathbf{E}_j, \Pi_j), \mu(Z_j)) \right] \\
& \leq \mathbb{E}_{(Z^{<j-1}, \Pi^{<j})} \left[6 \cdot \mathbb{E}_{(z \sim \mathcal{U}_y)} \left[\Lambda(\mu(T_z | Z^{<j-1}, \Pi^{<j}), \mu(Z_j)) \right] \right] \\
& \quad + \mathbb{E}_{(Z^{<j-1}, \Pi^{<j})} \left[\Lambda(\mu(Z_{j-1} | \mathbf{E}_{j-1}, \Pi_{j-1}), \mathcal{U}_y) \right] \\
& \hspace{10em} \text{(by Proposition 3.9 and linearity of expectation)} \\
& = 6 \cdot \mathbb{E}_{(Z^{<j-1}, \Pi^{<j})} \left[\mathbb{E}_{(z \sim \mathcal{U}_y)} \left[\Lambda(\mu(T_z | Z^{<j-1}, \Pi^{<j}), \mu(Z_j)) \right] \right] \hspace{5em} (*) \\
& \quad + \mathbb{E}_{(Z^{<j-1}, \Pi^{<j})} \left[\Lambda(\mu(Z_{j-1} | \mathbf{E}_{j-1}, \Pi_{j-1}), \mu(Z_{j-1})) \right] \\
& \hspace{10em} \text{(by definition } z_{j-1} \in \mathcal{Y} \text{ and } \mu(Z_{j-1}) = \mathcal{U}_y.) \\
& \leq 6 \cdot c' \cdot \underbrace{\left(\frac{CC(\pi_{\text{BHPC}}) + r \log m}{m^2} + \frac{j}{m} \right)}_{\text{Lemma 4.22}} + (j-1) \cdot c \cdot \underbrace{\left(\frac{CC(\pi_{\text{BHPC}}) + r \log m}{m^2} + \frac{r}{m} \right)}_{\text{Hypothesis}_{j-1}} \\
& \leq j \cdot c \cdot \left(\frac{CC(\pi_{\text{BHPC}}) + r \log m}{m^2} + \frac{r}{m} \right) \\
& \hspace{10em} \text{(where we replaced } j \leq r \text{ by } r \text{ in the first term and set } c = 6c')
\end{aligned}$$

This concludes the proof. \square

We now prove Lemma 4.22. The proof shows that any protocol that reveals information about the solution T_z to random instance z can be converted to a low-information protocol for externally ε -solving Set-Intersection. This will later be shown to be impossible. Let us state the lemma again:

Lemma 4.22. *There is a constant $c' > 0$ such that for any $j \in [r]$, we have:*

$$\begin{aligned}
\mathbb{E}_{(\mathbf{E}_j, \Pi_j)} \mathbb{E}_{x \sim \mathcal{U}_x} [\Lambda(\mu(T_x | \mathbf{E}_j, \Pi_j), \mu(T_x))] & \leq c' \cdot \left(\frac{CC(\pi_{\text{BHPC}}) + r \log m}{m^2} + \frac{j}{m} \right) \\
\mathbb{E}_{(\mathbf{E}_j, \Pi_j)} \mathbb{E}_{y \sim \mathcal{U}_y} [\Lambda(\mu(T_y | \mathbf{E}_j, \Pi_j), \mu(T_y))] & \leq c' \cdot \left(\frac{CC(\pi_{\text{BHPC}}) + r \log m}{m^2} + \frac{j}{m} \right).
\end{aligned}$$

Suppose towards a contradiction that this equation does not hold. We use π_{HPC} to design a protocol π_{SI} that can externally ε -solve the Set-Intersection problem (A_x, B_x) for a uniformly at random chosen $x \in \mathcal{X}$ and appropriately chosen $\varepsilon \in (0, 1)$ to be determined later (see Definition 4.3 for the notion of ε -solving).

Protocol π_{SI} : The protocol for ε -solving Set-Int using a protocol π_{HPC} for $\text{BHPC}_{m,r}$.

Input: An instance $(X, Y) \sim \mathcal{D}_{\text{Set-Int}}$ over the universe \mathcal{Y} and a number $j \in [r]$.

1. **Sampling the instance.** Alice and Bob create an instance (A, B, C, D) of $\text{BHPC}_{m,r}$ as

follows:

- (a) Using public coins, Alice and Bob sample an index $i \in [m]$ uniformly at random, and Alice sets $A_{x_i} = X$ and Bob sets $B_{x_i} = Y$ using their given inputs in **Set-Int**.
- (b) Using public coins, Alice and Bob sample $A_{x_1}, \dots, A_{x_{i-1}}$ from the A-side marginal of $\mathcal{D}_{\text{Set-Int}}$, and they sample $B_{x_{i+1}}, \dots, B_{x_m}$ from the B-side marginal of $\mathcal{D}_{\text{Set-Int}}$.
- (c) Using private coins, Alice samples A_{x_r} for $r \in \{i+1, \dots, n\}$ so that $(A_{x_r}, B_{x_r}) \sim \mathcal{D}_{\text{Set-Int}}$. Similarly Bob samples B_{x_ℓ} for $\ell \in \{1, \dots, i-1\}$. This completes construction of (\mathbf{A}, \mathbf{B}) .
- (d) Using public coins, Alice and Bob sample (C, D) completely from $\mathcal{D}_{\text{BHPC}}$ (this is possible by Observation 4.6 as $(\mathbf{A}, \mathbf{B}) \perp (C, D)$).

2. **Computing the answer.** For $q = 1$ to j , Alice and Bob do the following:

- (a) **Running protocol:** In round q , Alice and Bob run the round q of the protocol π_{BHPC} on the instance (A, B, C, D) by Alice playing P_A , Bob playing P_B , and both Alice and Bob simulating P_C and P_D with no communication (this is possible as both Alice and Bob know (C, D) entirely). Denote this transcript by Π_q .
- (b) **Fixing pointer:** Alice and Bob compute the pointer z_q using the fact that for any underlying instance $(A_x, B_x) \in (A, B) \setminus (A_{x_i}, B_{x_i})$ either Alice or Bob knows the entire instance. We use Π^* to denote the cumulative transcript generated by this step in all rounds.
- (c) They stop if $x_i = z_q$.

3. The players return $\Pi_{\text{Set-Int}} := (\Pi_1, \dots, \Pi_j, \Pi^*)$ from which $\mu(e^*)$ is calculated.

First, we show that the internal information cost of this protocol is small if the communication cost of Π_{BHPC} is small. This uses standard direct sum argument of information complexity. More concretely, we have the following:

Claim 4.23. $\text{IC}_{\mathcal{D}}(\pi_{\text{Set-Int}}) = O\left(\frac{CC(\pi_{\text{BHPC}})}{m} + \frac{j \log m}{m}\right)$.

The proof of Claim 4.23 is similar to that of Claim 5.6 of [ACK19]. We defer it to the Appendix C. At this point, we also need a bound on how well $\Pi_{\text{Set-Int}}$ can “almost” solve Set-Intersection. To this end, we have the following guarantee.

Claim 4.24. $\pi_{\text{Set-Int}}$ externally ε -solves Set-Intersection on \mathcal{D} where:

$$\varepsilon \geq \mathbb{E}_{(\mathbf{E}_j, \Pi_j)} \mathbb{E}_{x \sim \mathcal{U}_{\mathcal{X}}} [\Lambda(\mu(\mathbb{T}_x | \mathbf{E}_j, \Pi_j), \mu(\mathbb{T}_x))] - \frac{j}{m}.$$

Proof. This proof follows the proof of Claim 5.5 of [ACK19] almost verbatim. The only change is that we are working with positive triangular discrimination (Λ) instead of the total variation distance (Δ_{TVD}). However, as Λ is bounded by Δ_{TVD} (Proposition 3.8), a similar calculation yields the claim. By Definition 4.3, $\varepsilon = \mathbb{E}_{\Pi_{\text{Set-Int}}} [\Lambda(\mu(\mathbb{T} | \Pi_{\text{Set-Int}}), \mu(\mathbb{T}))]$. So we have:

$$\begin{aligned}
\mathbb{E}_{\Pi_{\text{Set-Int}}} [\Lambda(\mu(\mathbb{T} \mid \Pi_{\text{Set-Int}}), \mu(\mathbb{T}))] &= \mathbb{E}_{\mathbf{E}_j, \Pi_j, \Pi^*, \mathbf{I}} [\Lambda(\mu(\mathbb{T}_{x_1} \mid \Pi_{\text{Set-Int}}), \mu(\mathbb{T}_{x_1}))] && \text{(as } \mathbb{T} = \mathbb{T}_{x_1}\text{)} \\
&= \mathbb{E}_{\mathbf{E}_j, \Pi_j} \mathbb{E}_{\Pi^* \mid \mathbf{E}_j, \Pi_j, \mathbf{I}} [\Lambda(\mu(\mathbb{T}_{x_1} \mid \Pi_{\text{Set-Int}}), \mu(\mathbb{T}_{x_1}))] && \text{(as } \mathbf{I} \text{ is independent of } (\mathbf{E}_j, \Pi_j)\text{)} \\
&= \mathbb{E}_{\mathbf{E}_j, \Pi_j} \left[\sum_i \frac{1}{m} \mathbb{E}_{\Pi^* \mid \mathbf{E}_j, \Pi_j, \mathbf{I}=i} [\Lambda(\mu(\mathbb{T}_{x_i} \mid \Pi_{\text{Set-Int}}), \mu(\mathbb{T}_{x_i}))] \right] && \text{(as } \mathbf{I} \sim \mathcal{U}_{[m]}\text{)} \\
&= \mathbb{E}_{\mathbf{E}_j, \Pi_j} \left[\sum_{x_i \in Z^{<j}} \frac{1}{m} \Lambda(\mu(\mathbb{T}_{x_i} \mid \Pi_{\text{Set-Int}}), \mu(\mathbb{T}_{x_i})) + \sum_{x_i \notin Z^{<j}} \frac{1}{m} \Lambda(\mu(\mathbb{T}_{x_i} \mid \mathbf{E}_j, \Pi_j), \mu(\mathbb{T}_{x_i})) \right] \\
&&& \text{(If } x_i \notin Z^{<j} \text{ then } \Pi_{\text{Set-Int}} = (\mathbf{E}_j, \Pi_j)\text{)} \\
&\geq \mathbb{E}_{\mathbf{E}_j, \Pi_j} \left[\sum_{x_i \notin Z^{<j}} \frac{1}{m} \Lambda(\mu(\mathbb{T}_{x_i} \mid \mathbf{E}_j, \Pi_j), \mu(\mathbb{T}_{x_i})) \right] \\
&&& \text{(as the first sum term is at least 0)} \\
&\geq \mathbb{E}_{\mathbf{E}_j, \Pi_j} \mathbb{E}_i [\Lambda(\mu(\mathbb{T}_{x_i} \mid \mathbf{E}_j, \Pi_j), \mu(\mathbb{T}_{x_i}))] - \frac{j}{m}. && \text{(as } \Lambda \text{ is upper bounded by 1)}
\end{aligned}$$

□

Using Claim 4.23 and the lower bound on $\text{IC}_{\mathcal{D}}(\pi_{\text{Set-Int}})$ (Corollary 4.13), we have:

$$\varepsilon = O\left(\frac{CC(\pi_{\text{BHPC}})}{m^2} + \frac{j \log m}{m^2}\right)$$

Now, using Claim 4.24, we get:

$$\mathbb{E}_{(\mathbf{E}_j, \Pi_j)} \mathbb{E}_{x \sim \mathcal{U}_{\mathcal{X}}} [\Lambda(\mu(\mathbb{T}_x \mid \mathbf{E}_j, \Pi_j), \mu(\mathbb{T}_x))] - \frac{j}{n} = O\left(\frac{CC(\pi_{\text{BHPC}})}{m^2} + \frac{j \log m}{m^2}\right),$$

which concludes the proof of Lemma 4.22.

4.6 Putting it All Together

Given Lemma 4.11, we prove Theorem 4.1 in the following way: Consider a protocol π that is solving $\text{BMHPC}_{m,r}$ with communication cost $o(m^2)$. By Lemma 4.11, we have:

$$\begin{aligned}
\mathbb{E}_{(\mathbf{E}_r, \Pi_r)} [\Lambda(\mu(\mathbb{Z}_r \mid \mathbf{E}_r, \Pi_r), \mu(\mathbb{Z}_r))] &\leq 6c \cdot \frac{\mathbb{I}(\Pi; \mathbf{A}, \mathbf{C} \mid \mathbf{B}, \mathbf{D}) + \mathbb{I}(\Pi; \mathbf{B}, \mathbf{D} \mid \mathbf{A}, \mathbf{C})}{m^2} \\
&\stackrel{(*)}{\leq} 12c \cdot \frac{CC(\pi_{\text{BHPC}})}{m^2} = o(1),
\end{aligned}$$

where inequality (*) follows from Items 1 and 3 in Fact E.2. However, next, we show that, for a correct protocol for $\text{BMHPC}_{m,r}$, this quantity should be $\Omega(1)$, which contradicts the assumption that $CC(\pi_{\text{BHPC}}) = o(m^2)$. An entirely similar argument derives Theorem 4.2 from Lemma 4.21. The only difference between these two arguments is the bound on r : We have to assume $r = o(\sqrt{m})$ because of the additive r^2/m factor in Lemma 4.21 (when applied with on the r -th round of the protocol).

Lemma 4.25. *Any protocol that solves $\text{BMHPC}_{m,r}$ on distribution $\mathcal{D}_{\text{BMHPC}}$, or $\text{BHPC}_{m,r}$, on distribution $\mathcal{D}_{\text{BHPC}}$, with constant probability must have:*

$$\mathbb{E}_{(\mathbf{E}_r, \Pi_r)} [\Lambda(\mu(\mathbf{Z}_r | \mathbf{E}_r, \Pi_r), \mu(\mathbf{Z}_r))] = \Omega(1).$$

Proof. Let b denote the modulus function such that $b(z_k) = i \pmod 2$ iff $z_r = x_i$ or y_i depending on where r is even or odd. If the protocol π computes $\text{BMHPC}_{m,r}$ or $\text{BHPC}_{m,r}$ with probability $2/3$, we have the following inequality:

$$\begin{aligned} 2/3 &= \mathbb{E}_{\mathbf{E}_r, \Pi_r} \Pr_{\mathbf{Z}_r | \mathbf{E}_r, \Pi_r} [b(\mathbf{Z}_r) = \mathcal{O}_\pi(\mathbf{E}_r, \Pi_r)] \\ &\stackrel{(1)}{\leq} \mathbb{E}_{\mathbf{E}_r, \Pi_r} \left[\Pr_{\mathbf{Z}_r \sim \mathcal{U}_{\mathcal{X}}} [b(\mathbf{Z}_r) = \mathcal{O}_\pi(\mathbf{E}_r, \Pi_r)] + \|\mu(b(\mathbf{Z}_r) | \mathbf{E}_r, \Pi_r) - \mathcal{U}_{0,1}\|_1 \right] \\ &\stackrel{(2)}{\leq} \mathbb{E}_{\mathbf{E}_r, \Pi_r} \left[\Pr_{\mathbf{Z}_r \sim \mathcal{U}_{\mathcal{X}}} [b(\mathbf{Z}_r) = \mathcal{O}_\pi(\mathbf{E}_r, \Pi_r)] + \|\mu(\mathbf{Z}_r | \mathbf{E}_r, \Pi_r) - \mathcal{U}_{\mathcal{X}}\|_1 \right] \\ &= \frac{1}{2} + \mathbb{E}_{\mathbf{E}_r, \Pi_r} [\|\mu(\mathbf{Z}_r | \mathbf{E}_r, \Pi_r) - \mathcal{U}_{\mathcal{X}}\|_1] \end{aligned}$$

where (1) holds because of the simple fact that $\Pr_p[\mathcal{E}] \leq \Pr_q[\mathcal{E}] + \|p - q\|_1$ where p and q are two distributions over a sample space of which \mathcal{E} is an event (see Footnote 5), and (2) holds because of data processing inequality. This implies:

$$\begin{aligned} \mathbb{E}_{\mathbf{E}_r, \Pi_r} [\|\mu(\mathbf{Z}_r | \mathbf{E}_r, \Pi_r) - \mathcal{U}_{0,1}\|_1] \geq 1/6 &\Rightarrow \left(\mathbb{E}_{\mathbf{E}_r, \Pi_r} [\|\mu(\mathbf{Z}_r | \mathbf{E}_r, \Pi_r) - \mathcal{U}_{0,1}\|_1] \right)^2 \geq 1/36 \\ &\Rightarrow \mathbb{E}_{\mathbf{E}_r, \Pi_r} [\|\mu(\mathbf{Z}_r | \mathbf{E}_r, \Pi_r) - \mathcal{U}_{0,1}\|_1^2] \geq 1/36 \\ &\Rightarrow \mathbb{E}_{\mathbf{E}_r, \Pi_r} [\Lambda(\mu(\mathbf{Z}_r | \mathbf{E}_r, \Pi_r), \mathcal{U}_{0,1})] \geq 1/288 = \Omega(1), \end{aligned}$$

which completes the proof. □

5 Reduction From BMHPC to Degeneracy

In this section we prove streaming lower bounds for degeneracy related problems. Precisely, we prove the following theorem.

Theorem 5.1. *Given an integer k and an n -vertex graph G , any p -pass streaming algorithm that can check whether $\kappa(G) \leq k$ or not requires $\Omega(n^2/p^3 - (n \log n)/p)$ space.*

This immediately implies the following corollary for semi-streaming algorithms.

Corollary 5.2. *A semi-streaming algorithm for any of the following problems on an n -vertex graph G requires $\tilde{\Omega}(n^{1/3})$ passes.*

- Check whether the degeneracy $\kappa(G) \leq k$ for a given integer k .
- Exactly compute the value of $\kappa(G)$.
- Find a degeneracy ordering of G .
- Find a non-empty k -core of G for a given value of k (or report *NONE* if none exists).

We prove Theorem 5.1 by reduction from BMHPC. Suppose we are given an instance of $\text{BMHPC}_{m,r}$. We first describe a gadget graph G based on this instance, and prove that this graph's degeneracy $\kappa(G)$ being $\leq k$ or $> k$ (for some particular value k) can be used to determine whether the solution to the BMHPC instance is 0 or 1. Then, along standard lines, we show how a streaming algorithm that solves this boolean version of the degeneracy problem can be used to design a communication protocol for $\text{BMHPC}_{m,r}$, implying that the space used by the streaming algorithm must be at least the communication complexity of $\text{BMHPC}_{m,r}$.

5.1 Construction of the Gadget Graph

In Figure 1, we show the graph constructed for a particular instance of BMHPC. We then formally describe the construction and refer to the figure for examples.

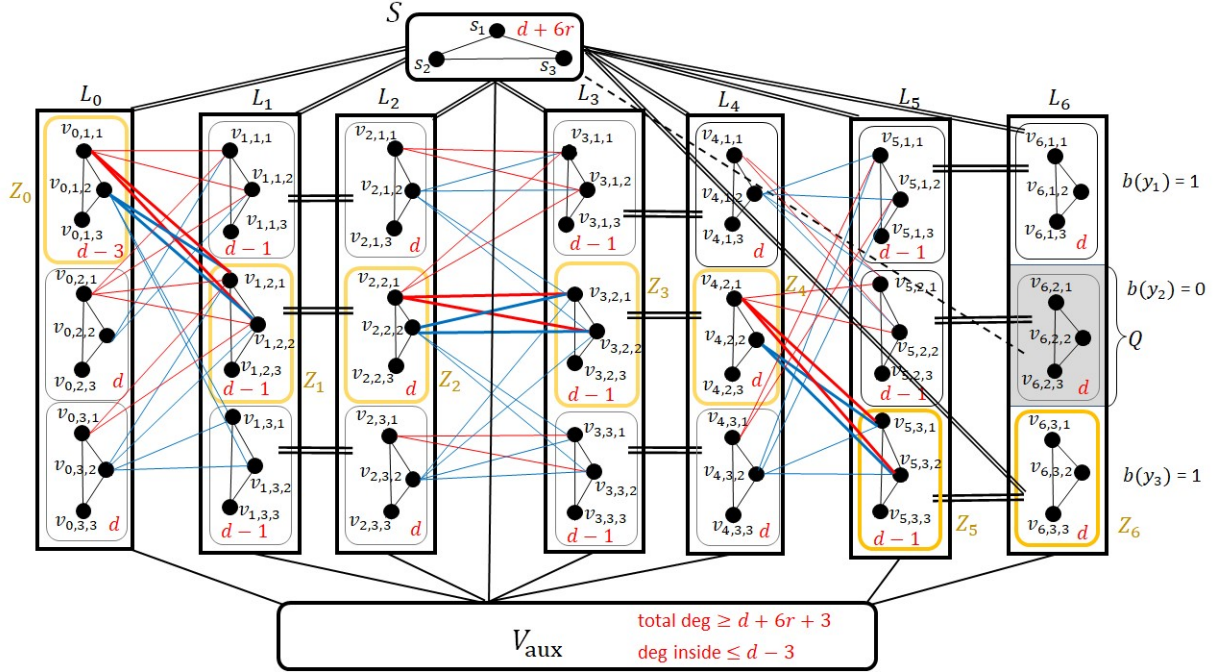

Figure 1: The gadget graph G for the following instance of $\text{BMHPC}_{3,3}$. $\mathbf{A}^1 = \{A_{x_1}^1 = \{y_1, y_2\}, A_{x_2}^1 = \{y_1, y_2\}, A_{x_3}^1 = \{y_2\}\}$. $\mathbf{B}^1 = \{B_{x_1}^1 = \{y_2, y_3\}, B_{x_2}^1 = \{y_1\}, B_{x_3}^1 = \{y_2, y_3\}\}$. $\mathbf{C}^2 = \{C_{y_1}^2 = \{x_1\}, C_{y_2}^2 = \{x_1, x_2\}, C_{y_3}^2 = \{x_3\}\}$. $\mathbf{D}^2 = \{D_{y_1}^2 = \{x_1, x_2\}, D_{y_2}^2 = \{x_2, x_3\}, D_{y_3}^2 = \{x_2, x_3\}\}$. $\mathbf{A}^3 = \{A_{x_1}^3 = \{y_2\}, A_{x_2}^3 = \{y_2, y_3\}, A_{x_3}^3 = \{y_1\}\}$. $\mathbf{B}^3 = \{B_{x_1}^3 = \{y_1, y_2\}, B_{x_2}^3 = \{y_3\}, B_{x_3}^3 = \{y_1, y_3\}\}$ (we skip $\mathbf{C}^1, \mathbf{D}^1, \mathbf{A}^2, \mathbf{B}^2, \mathbf{C}^3, \mathbf{D}^3$ because they are redundant). Hence, $z_0 = x_1$; $z_1 = t_{x_1}^1 = y_2$; $z_2 = t_{y_2}^2 = x_2$; and $z_3 = t_{x_2}^3 = y_3$. Therefore, the answer to this instance is $b(y_3) = 1$.

Here, a double line between two sets of nodes (e.g., the one between sets S and L_0) signifies that all possible cross edges are present between those two sets. A single line between two sets (e.g., the one between V_{aux} and L_0) denotes that some edges maybe present between them. A dashed line (e.g., the one between sets S and Q) denotes that absolutely no edge is present between them. For each triple, the number (in red) inside the box containing it denotes the degree of each node in the triple. The red and blue edges encode the inputs. The thick edges are between triples representing z_i and z_{i+1} .

The graph G has $2r + 1$ layers L_0, L_1, \dots, L_{2r} . Each layer L_ℓ has $3m$ nodes. Edges between two of these layers are always between successive layers L_ℓ and $L_{\ell+1}$ for some ℓ .

Layer nodes. For each $\ell \in [0, 2r]$ and for each $i \in [m]$, layer L_ℓ has 3 nodes (a triple), denoted by $v_{\ell,i,1}, v_{\ell,i,2}$, and $v_{\ell,i,3}$. For $\ell = 0$, this triple represents x_i . For $\ell \geq 0$, in layers $L_{4\ell+1}$ and $L_{4\ell+2}$ (resp.

$L_{4\ell+3}$ and $L_{4\ell+4}$), it represents y_i (resp. x_i). For instance, in Figure 1, the triple $(v_{3,2,1}, v_{3,2,2}, v_{3,2,3})$ represents x_2 and $(v_{6,1,1}, v_{6,1,2}, v_{6,1,3})$ represents y_1 . Formally, we add the following set of vertices.

$$V_L = \{v_{\ell,i,c} : \ell \in [0, 2r], i \in [m], c \in \{1, 2, 3\}\}$$

Special nodes. Outside the layers, we have a set S of three special nodes s_1, s_2, s_3 .

We now define the edges on the node set $V_L \cup S$.

Edges within each triple. Each triple forms a triangle. Formally, we add the edge set E_1 to G , where

$$E_1 = \{(v_{\ell,i,1}, v_{\ell,i,2}), (v_{\ell,i,2}, v_{\ell,i,3}), (v_{\ell,i,1}, v_{\ell,i,3}) : \ell \in [0, 2r], i \in [m]\}$$

Edges between layers $L_{2\ell-1}$ and $L_{2\ell}$. As mentioned above, for each $\ell \in [r]$, either both of the i th triples in layers $L_{2\ell-1}$ and $L_{2\ell}$ represent x_i or both represent y_i . We add all 9 cross edges between these two triples representing the same element. E.g., in Figure 1, we have all cross edges (denoted by a double line) between the triples $(v_{1,1,1}, v_{1,1,2}, v_{1,1,3})$ and $(v_{2,1,1}, v_{2,1,2}, v_{2,1,3})$, both of which represent y_1 . Formally, we add the edge set E_2 to G , where

$$E_2 = \{\{v_{2\ell-1,i,c} : c \in \{1, 2, 3\}\} \times \{v_{2\ell,i,c} : c \in \{1, 2, 3\}\} : \ell \in [r], i \in [m]\}$$

Edges between layers $L_{4\ell}$ and $L_{4\ell+1}$. The edges connecting layers of the form $L_{4\ell}$ and $L_{4\ell+1}$ encode the inputs $\mathbf{A}^{2\ell+1}$ and $\mathbf{B}^{2\ell+1}$. In particular, for each $i \in [m]$, the edges leaving $v_{4\ell,i,1}$ and $v_{4\ell,i,2}$ encode the sets $A_{x_i}^{2\ell+1}$ and $B_{x_i}^{2\ell+1}$ respectively. Precisely, if the set $A_{x_i}^{2\ell+1}$ contains the element y_j , then we join $v_{4\ell,i,1}$ to both the nodes $v_{4\ell+1,j,1}$ and $v_{4\ell+1,j,2}$. Similarly, if $B_{x_i}^{2\ell+1}$ contains y_j , then we join $v_{4\ell,i,2}$ to both $v_{4\ell+1,j,1}$ and $v_{4\ell+1,j,2}$ (for example, see the families $(\mathbf{A}^1, \mathbf{B}^1)$ and $(\mathbf{A}^3, \mathbf{B}^3)$ in Figure 1, and the corresponding edges between L_0 and L_1 and between L_4 and L_5 respectively). Formally, we add the edge sets E_A and E_B to G , where

- $E_A = \{\{v_{4\ell,i,1}\} \times \{v_{4\ell+1,j,1}, v_{4\ell+1,j,2}\} : y_j \in A_{x_i}^{2\ell+1}, \ell \in [0, \lfloor (r-1)/2 \rfloor], j \in [m]\}$
- $E_B = \{\{v_{4\ell,i,2}\} \times \{v_{4\ell+1,j,1}, v_{4\ell+1,j,2}\} : y_j \in B_{x_i}^{2\ell+1}, \ell \in [0, \lfloor (r-1)/2 \rfloor], j \in [m]\}$

Edges between layers $L_{4\ell+2}$ and $L_{4\ell+3}$. The edges between layers of the form $L_{4\ell+2}$ and $L_{4\ell+3}$ similarly encode the inputs $\mathbf{C}^{2\ell+2}$ and $\mathbf{D}^{2\ell+2}$. The construction is same as above, except with $A_{x_i}^{2\ell+1}$ and $B_{x_i}^{2\ell+1}$ replaced by $C_{y_i}^{2\ell+2}$ and $D_{y_i}^{2\ell+2}$ respectively, and y_j replaced by x_j (again, see the families \mathbf{C}^2 and \mathbf{D}^2 in the example in Figure 1 and the corresponding edges between L_2 and L_3). Formally, we add the edge sets E_C and E_D to G , where

- $E_C = \{\{v_{4\ell+2,i,1}\} \times \{v_{4\ell+3,j,1}, v_{4\ell+3,j,2}\} : x_j \in C_{y_i}^{2\ell+2}, \ell \in [0, \lfloor r/2 \rfloor - 1], j \in [m]\}$
- $E_D = \{\{v_{4\ell+2,i,2}\} \times \{v_{4\ell+3,j,1}, v_{4\ell+3,j,2}\} : x_j \in D_{y_i}^{2\ell+2}, \ell \in [0, \lfloor r/2 \rfloor - 1], j \in [m]\}$

Edges on special nodes. Recall that each element in \mathcal{X} and \mathcal{Y} has a bit associated with it. The special nodes s_1, s_2, s_3 are connected to each other and also to all the layer nodes except those representing bit-0-elements in the last layer L_{2r} (in Figure 1, this is the triple representing y_2 in L_6). Formally, if r is even, let $Q := \{v_{2r,i,c} : b(x_i) = 0, c \in \{1, 2, 3\}\}$, and otherwise, $Q := \{v_{2r,i,c} : b(y_i) = 0, c \in \{1, 2, 3\}\}$. Then, we add the edge set E_S to G , where

$$E_S = \{(s_1, s_2), (s_2, s_3), (s_1, s_3)\} \cup (\{s_1, s_2, s_3\} \times (V_L \setminus Q))$$

Let $V' := V_L \cup S$ and $E' := E_1 \cup E_2 \cup E_S \cup E_A \cup E_B \cup E_C \cup E_D$. The graph constructed so far is $G' = (V', E')$.

Auxiliary edges. We add some auxiliary vertices V_{aux} and edges $E_{\text{aux}} \subseteq V_{\text{aux}} \times (V' \cup V_{\text{aux}})$ to obtain the final graph

$$G = (V' \cup V_{\text{aux}}, E' \cup E_{\text{aux}})$$

where we ensure the following degrees for $d := 6mr + 3m$ (in Figure 1, these degrees are written in the boxes containing the triples).

- $\deg(v_{0,1,1}) = \deg(v_{0,1,2}) = \deg(v_{0,1,3}) = d - 3$
- For each $i \in [2, m]$, $c \in \{1, 2, 3\}$, $\deg(v_{0,i,c}) = d$.
- For each $\ell \in [r]$, $i \in [m]$, $c \in \{1, 2, 3\}$, $\deg(v_{2\ell-1,i,c}) = d - 1$.
- For each $\ell \in [r]$, $i \in [m]$, $c \in \{1, 2, 3\}$, $\deg(v_{2\ell,i,c}) = d$.
- $\deg(s_1) = \deg(s_2) = \deg(s_3) = d + 6r$
- For each $u \in V_{\text{aux}}$, $\deg(u) \geq d + 6r + 3$.

Lemma 5.3 states that such a construction of V_{aux} and E_{aux} is possible with just the knowledge of the vertex degrees in G' (rather than the actual graph). We shall use this fact in our reduction. The proof with the explicit construction is deferred to Appendix D.

Lemma 5.3. *Given the degree of each node in $G' = (V', E')$, we can add vertices V_{aux} and edges $E_{\text{aux}} \subseteq V_{\text{aux}} \times (V' \cup V_{\text{aux}})$ so that the graph $G = (V' \cup V_{\text{aux}}, E' \cup E_{\text{aux}})$ has the above vertex-degrees and $\Theta(mr)$ nodes in total. Furthermore, the degree of any vertex in the induced subgraph $G[V_{\text{aux}}]$ is $\leq d - 3$.*

This completes the construction of the graph G .

5.2 The Analysis

In this section, we prove the following lemma that says that we can use the degeneracy value of the gadget graph constructed in the last section to determine the solution to the corresponding instance of BMHPC.

Lemma 5.4. *Given an instance of $\text{BMHPC}_{m,r}$, let G denote the gadget graph constructed in Section 5.1. If $b(z_r) = 0$, then $\kappa(G) \geq d - 2$. Otherwise, $\kappa(G) \leq d - 3$.*

We set up some notations to prove the above lemma.

Triples corresponding to pointers. We are particularly interested in the triples of nodes that represent the pointers z_i in the relevant layers. In layer L_0 , we are interested in the triple representing the first pointer z_0 ; call it Z_0 . Then in *each* of the layers L_1 and L_2 , we are interested in the triple representing the second pointer z_1 ; call these triples Z_1 and Z_2 respectively. In general, in layers $L_{2\ell-1}$ and $L_{2\ell}$, the triples that represent the pointer z_ℓ are called $Z_{2\ell-1}$ and $Z_{2\ell}$ respectively. In other words, the triple Z_ℓ corresponds to the pointer $z_{\lceil \ell/2 \rceil}$ (see Figure 1 for example. Z_0 is the triple representing $z_0 = x_1$; both Z_1 and Z_2 represent $z_1 = y_2$; both Z_3 and Z_4 represent $z_2 = x_2$; and finally both Z_5 and Z_6 represent $z_3 = y_3$.)

Let us now formalize this. Define the function $i^* : [0, 2r] \rightarrow [m]$ as follows:

For $\ell \in [0, 2r]$, let $\ell' := \lceil \ell/2 \rceil$. Then $i^*(\ell)$ is the unique index i such that

$$z_{\ell'} = \begin{cases} x_i & \text{if } \ell' \text{ is even} \\ y_i & \text{if } \ell' \text{ is odd} \end{cases}$$

Then $Z_\ell := (v_{\ell, i^*(\ell), 1}, v_{\ell, i^*(\ell), 2}, v_{\ell, i^*(\ell), 3})$, i.e., the triple representing $z_{\lceil \ell/2 \rceil}$ in layer L_ℓ .

High-level proof overview. To prove Lemma 5.4, we perform the peeling algorithm on the graph G . We shall show that the first $6r + 3$ iterations of this algorithm basically chase the hidden pointers over the successive layers: to be precise, the first three iterations remove the triple Z_0 , the next three remove Z_1 , and so on and so forth until iterations $6r + 1, 6r + 2$, and $6r + 3$ remove Z_{2r} (see Figures 2 to 4 for a sketch of how this proceeds). Then we have two cases as follows.

If $b(z_r) = 0$, then removal of Z_{2r} does not reduce the degrees of the nodes in S . We show that in this case, immediately after the removal of Z_{2r} , the peeling algorithm must remove a node with degree $\geq d - 2$ (Figure 5). Thus, by Fact 3.15, we must have $\kappa(G) \geq d - 2$.

Otherwise, if $b(z_r) = 1$, then Z_{2r} is indeed connected to the nodes s_1, s_2, s_3 . We show that removal of Z_{2r} reduce their degrees enough so that the peeling algorithm must remove S in the next three iterations. This leads to the peeling of all the remaining nodes in the graph such that during deletion, their degree is at most $d - 3$ (see Figure 6). Then, by Fact 3.15, we must have $\kappa(G) \leq d - 3$. This will complete the proof of the lemma.

Proof details. To formally prove Lemma 5.4, we first show that the peeling algorithm indeed peels off the Z_ℓ 's one by one, and that some invariants on the vertex-degrees hold after these deletions. We start with a technical claim that we use multiple times in the proof.

Claim 5.5. *Suppose that in a graph H , the min-degree nodes are exactly a set of three nodes $U = \{u_1, u_2, u_3\}$, which are all adjacent to each other, and have degree δ each (all other nodes in H have degree $\geq \delta + 1$). Then, the peeling algorithm on H removes the nodes in U (in some order) in the first three iterations. Further, during deletion, each u_i has degree $\leq \delta$.*

Proof. Since U is the exact set of min-degree nodes in H , iteration 1 of the peeling algorithm must delete one of the u_i 's. WLOG, say it deletes u_1 . Then, $\deg(u_2)$ and $\deg(u_3)$ drop to $\delta - 1$ (since they were neighbors of u_1); at the same time, since the degree of any other node was at least $\delta + 1$, it can drop to at least δ . Therefore, u_2 and u_3 remain the min-degree nodes and one of them must be removed in iteration 2. WLOG, say it's u_2 . As a result, the degree of u_3 drops to $\delta - 2$ (since u_2 was its neighbor) while the degree of any other node remains at least $\delta - 1$. Hence, iteration 3 deletes u_3 . Clearly, when each u_i was deleted, its degree was $\leq \delta$. \square

We now list the invariants and prove that they are maintained.

Lemma 5.6. *For each $\ell \in [0, 2r]$, the following invariants hold:*

Inv. (1). Just before iteration $3\ell + 1$, any $s \in S$ has $\deg(s) = d + 6r - 3\ell$ and any $u \in V_{aux}$ has $\deg(u) \geq d + 6r + 3 - 3\ell$.

Inv. (2). If ℓ is even, then just before iteration $3\ell + 1$,

- (a) each node in the triple Z_ℓ has degree $d - 3$
- (b) for any vertex $v \in L_j$ for $j \leq \ell - 1$, we have $\deg(v) \geq d - 2$
- (c) for any vertex $v \in L_j$ for an odd $j \geq \ell + 1$, we have $\deg(v) = d - 1$
- (d) for any vertex $v \notin Z_\ell$ in a layer L_j for an even $j \geq \ell$, we have $\deg(v) = d$.

Inv. (3). If ℓ is odd, then just before iteration $3\ell + 1$,

- (a) the triple Z_ℓ has degree $(d - 3, d - 3, d - 1)$
- (b) for any vertex $v \notin Z_\ell$ in layer L_ℓ or in L_j for any $j \leq \ell - 2$, we have $\deg(v) \geq d - 2$
- (c) for any vertex $v \in L_j$ for an odd $j \geq \ell + 2$, we have $\deg(v) = d - 1$

(d) for any vertex $v \in L_j$ for an even $j \geq \ell - 1$, we have $\deg(v) = d$.

Inv. (4). Iterations $(3\ell + 1, 3\ell + 2, 3\ell + 3)$ delete the vertices in the triple Z_ℓ in some order. Furthermore, during deletion, each vertex has degree $\leq d - 3$.

Proof. We prove this by induction on ℓ .

Base case. Consider the base case of $\ell = 0$. Since ℓ is even, we need to ensure Invs. (1), (2), and (4) hold. Indeed, Inv. (3) is vacuously true. Observe that by definition, $Z_0 = (v_{0,1,1}, v_{0,1,2}, v_{0,1,3})$. Before iteration 1, i.e., initially (see Figure 1), the construction ensures that each node in Z_0 has degree $d - 3$. Hence, Inv. 2(a) holds. Inv. 2(b) holds vacuously. Our construction sets the degree of any vertex $v \in L_j$ for odd j to be $d - 1$, and that of any vertex outside Z_0 in layer L_j for even j to be d . Thus, Inv. 2(c) and Inv. 2(d) also hold. The initial degree of any node in S is $d + 6r$ and that of any node in V_{aux} is at least $d + 6r + 3$. This means Inv. (2) holds as well.

To see that Inv. (4) holds, note that initially the min-degree vertices in the current graph are precisely the nodes in Z_0 , each with degree $d - 3$. All remaining nodes have degree $\geq d - 1$. Hence, the premise of Claim 5.5 holds with $H = G, U = Z_0$, and $\delta = d - 3$. Therefore, by Claim 5.5, iterations (1, 2, 3) delete Z_0 in some order, and during deletion, the degrees of these nodes are $\leq d - 3$. Hence, Inv. (4) also holds, and we are done with the base case.

Inductive Step. Assume by induction hypothesis (henceforth “IH”) that for some $\ell \in [0, 2r - 1]$, all the invariants hold for all values $\leq \ell$. Then we show that they hold for $\ell + 1$ as well.

First consider Inv. (1). By IH Inv. (1), any node $s \in S$ had degree $d + 6r - 3\ell$ before iteration $3\ell + 1$. By IH Inv. (4), the next three iterations delete nodes in Z_ℓ , each of which shared an edge with each $s \in S$ (since $\ell \leq 2r - 1$). Hence, $\deg(s)$ drops to $d + 6r - 3(\ell + 1)$ before iteration $3(\ell + 1) + 1$. By the same invariant, any $u \in V_{\text{aux}}$ had degree $\geq d + 6r + 3 - 3\ell$ before iteration $3\ell + 1$. The deletion of Z_ℓ can reduce its degree by at most 3, implying that $\deg(u) \geq d + 6r + 3 - 3(\ell + 1)$ before iteration $3(\ell + 1) + 1$. Therefore, Inv. (1) holds for $\ell + 1$.

For the remaining invariants, we analyze separate cases for whether $\ell + 1$ is even or odd.

Case 1: $\ell + 1$ is odd. We need to show that Invs. (3) and (4) hold for $\ell + 1$. Inv. (2) is vacuously true.

We know that ℓ is even, and by IH, Invs. (2), and (4) hold for ℓ . By Inv. (2), we know the situation before iteration $3\ell + 1$, and by Inv. (4), we know that the iterations $(3\ell + 1, 3\ell + 2, 3\ell + 3)$ remove Z_ℓ , leading to the current graph just before iteration $3(\ell + 1) + 1$ (see Figure 2 for an example with $\ell = 0$ and Figure 3 for an example with $\ell = 2$ for the graph given in Figure 1).

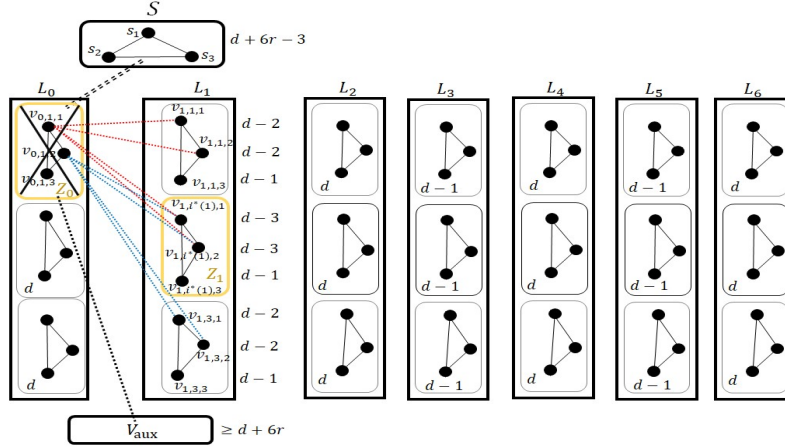

Figure 2: The status of the graph just before iteration 4. Z_0 was deleted in the last three iterations, and hence crossed out. The dotted lines denote edges that were deleted as a result. A double dotted-line between two sets of nodes signifies that originally all cross edges were present between them. Next to a node, its current degree is given. If all nodes in a set have the same degree, the value is given next to the set.

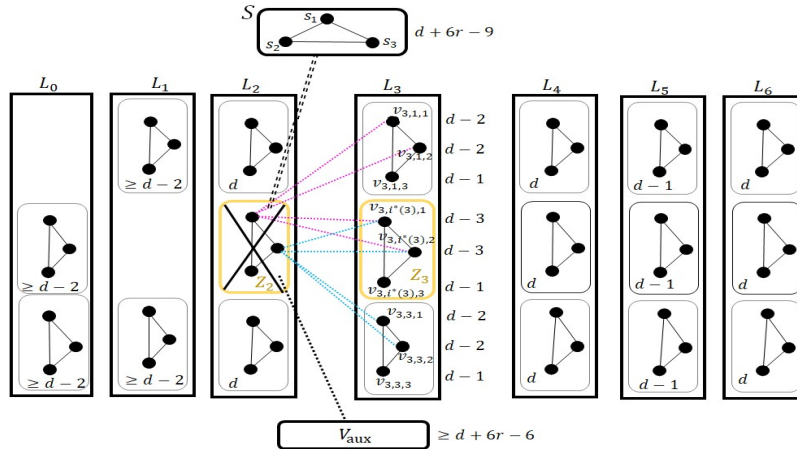

Figure 3: The status of the graph just before iteration 10. Z_2 was deleted in the last three iterations, and hence crossed out. The dotted lines denote edges that were deleted as a result. A double dotted-line between two sets of nodes signifies that originally all cross edges were present between them. Next to a node, its current degree is given. If all nodes in a set have the same degree, the value is given next to the set.

We check which nodes are affected by the removal of Z_ℓ . In the original graph, the only neighbors of Z_ℓ in layer $L_{\ell-1}$ (if exists) were the nodes in $Z_{\ell-1}$, which were removed even before Z_ℓ (by IH Inv. (4)). Thus, its only neighbors in the current graph are in layer $L_{\ell+1}$, S , or V_{aux} .

Suppose ℓ is of the form $4a + 2$ (see Figure 3). Then the nodes in layer $\ell + 1$ represent elements in \mathcal{X} . Recall that Z_ℓ corresponds to the element $z_{\ell'} \in \mathcal{Y}$ where $\ell' = \ell/2$. By construction, the edges from Z_ℓ connect to nodes that represent elements in $C_{z_{\ell'}}^{\ell'+1}$ and $D_{z_{\ell'}}^{\ell'+1}$. Consider any $x_i \in \mathcal{X}$. We have three cases: (i) x_i is in exactly one of the sets $C_{z_{\ell'}}^{\ell'+1}$ and $D_{z_{\ell'}}^{\ell'+1}$, (ii) x_i is in neither of them, and (iii) x_i is in both, i.e., $x_i = z_{\ell'+1}$. If ℓ is of the form $4a$ (see Figure 2), we make the analogous arguments replacing \mathcal{X} by \mathcal{Y} , C and D by A and B , and x_i by y_i . We now analyze each of these cases.

By IH Inv. 2(c), before iteration $3\ell + 1$, each node in the triple $(v_{\ell+1,i,1}, v_{\ell+1,i,2}, v_{\ell+1,i,3})$ had degree $d - 1$. Therefore, after the removal of Z_ℓ , i.e., just before iteration $3(\ell + 1) + 1$, it can

have the following degrees. In case (i), the triple has degrees $(d - 2, d - 2, d - 1)$. This is because our construction ensures that exactly one of the vertices $v_{\ell, i^*(\ell), 1}$ and $v_{\ell, i^*(\ell), 2}$ had edges to both $v_{\ell+1, i, 1}$ and $v_{\ell+1, i, 2}$, and the other had none. In case (ii), it has degrees $(d - 1, d - 1, d - 1)$. This is because none of the nodes in Z_ℓ had any edge to the triple representing x_i . In case (iii), the triple representing x_i is precisely the triple $Z_{\ell+1}$ and has degrees $(d - 3, d - 3, d - 1)$. This follows since both nodes $v_{\ell, i^*(\ell), 1}$ and $v_{\ell, i^*(\ell), 2}$ had edges to both $v_{\ell+1, i, 1}$ and $v_{\ell+1, i, 2}$.

The above analysis immediately implies that Inv. 3(a) holds for $\ell + 1$. Now, for possible values of r , consider nodes in L_r . For $r = \ell + 1$, we see that any node $v \notin Z_{\ell+1}$ in layer L_r has degree $\geq d - 2$. For $r \leq \ell - 1 = (\ell + 1) - 2$, by IH Inv. 2(b), a vertex in L_r had degree $\geq d - 2$ before iteration $3\ell + 1$, which still holds after iteration $3\ell + 3$: this is because, as noted above, removal of Z_ℓ does not affect any of them. Therefore, Inv. 3(b) also holds for $\ell + 1$.

For an odd $j \geq \ell + 3 = (\ell + 1) + 2$, by IH Inv. 2(c), any vertex in L_j had degree $d - 1$ before iteration $3\ell + 1$ and it is still true after iteration $3\ell + 3$ since removal of Z_ℓ cannot affect them. Thus, Inv. 3(c) holds for $\ell + 1$. Finally, for an even $j \geq \ell = (\ell + 1) - 1$, by IH Inv. 2(d), any vertex $v \notin Z_\ell$ had degree d before iteration $3\ell + 1$; since removal of Z_ℓ doesn't affect the other vertices in these layers, their degrees still have that value and Inv. 3(d) holds for $\ell + 1$. Therefore, we have shown that Inv. (3) holds for $\ell + 1$.

It remains to prove Inv. (4). Since Inv. (3) holds for $\ell + 1$, we know that just before iteration $3(\ell + 1) + 1$, the triple $Z_{\ell+1}$ has degrees $(d - 3, d - 3, d - 1)$, and any other node has degree at least $d - 2$. This means the min-degree nodes in the current graph are in Z_ℓ ; precisely, they are $v_{\ell, i^*(\ell), 1}$ and $v_{\ell, i^*(\ell), 2}$, each having degree $d - 3$. WLOG, say iteration $3\ell + 1$ deletes $v_{\ell, i^*(\ell), 1}$. Then, $\deg(v_{\ell, i^*(\ell), 2})$ drops to $d - 4$, and $\deg(v_{\ell, i^*, 3})$ drops to $d - 2$. Notice that the only other nodes that can be affected by the deletion are in either layer L_ℓ or layer $L_{\ell+2}$. By Inv. 3(d) for $\ell + 1$, since any node in these layers had degree d before iteration $3(\ell + 1) + 1$, their degree can drop to at least $d - 1$ after the iteration. Also by Inv. 3, the vertices in other layers had degrees $\geq d - 2$ before the iteration, and since they are unaffected, their degrees remain so. Hence, the current graph has the unique min-degree node $v_{\ell, i^*, 2}$, which is removed by iteration $3\ell + 2$. Now, $\deg(v_{\ell, i^*, 3})$ drops to $d - 3$. But degrees of vertices in layers L_ℓ or $L_{\ell+2}$ can now drop to at least $d - 2$, while any other node maintains degree $\geq d - 2$ as it's unaffected by the deletion. Hence, $v_{\ell, i^*, 3}$ is the unique min-degree node in the current graph and is removed by iteration $3(\ell + 1) + 2$. Also observe that when each vertex was peeled, its degree was $\leq d - 3$. Thus, we have proven that Inv. (4) holds for $\ell + 1$.

Case 2: $\ell + 1$ is even. We need to show that Invs. (2) and (4) hold for $\ell + 1$. Inv. (3) holds vacuously.

We know that ℓ is odd, and by IH, Invs. (3) and (4) hold for ℓ . Analogous to the last case, by Inv. (3), we know the situation before iteration $3\ell + 1$, and by Inv. (4), we know that the iterations $(3\ell + 1, 3\ell + 2, 3\ell + 3)$ remove Z_ℓ , leading to the current graph just before iteration $3(\ell + 1) + 1$ (see Figure 4 for an example with $\ell = 1$ for the graph in Figure 1).

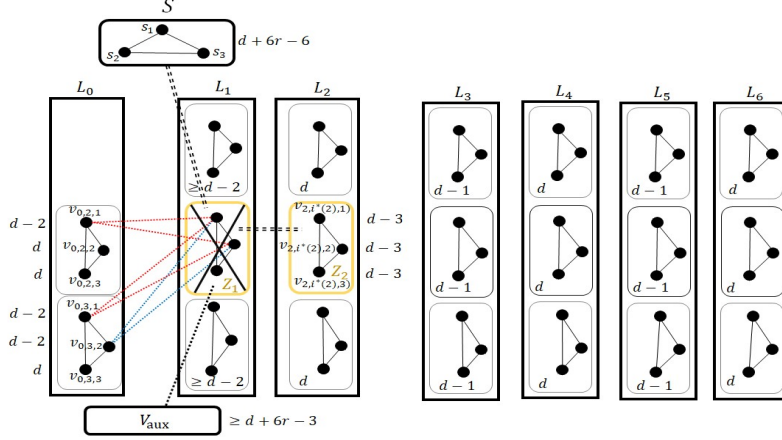

Figure 4: The status of the graph just before iteration 7. Z_1 was deleted in the last three iterations, and hence crossed out. The dotted lines denote edges that were deleted as a result. A double dotted-line between two sets of nodes signifies that originally all cross edges were present between them. Next to a node, its current degree is given. If all nodes in a set have the same degree, the value is given next to the set.

We check which nodes might be affected by the deletion of Z_ℓ in the last three iterations. By construction, Z_ℓ has edges to $Z_{\ell+1}$, to some vertices in $L_{\ell-1}$, to S , or to V_{aux} .

First consider vertices in $Z_{\ell+1}$. By IH Inv. 3(d), these nodes had degree d before iteration $3\ell + 1$. Further, all of them were adjacent to each node in Z_ℓ . Hence, after Z_ℓ gets deleted, i.e., just before iteration $3(\ell + 1) + 1$, each of them has degree $d - 3$. This shows that Inv. 2(a) holds for $\ell + 1$.

Now consider the nodes in layer $L_{\ell-1}$. Suppose ℓ is of the form $4a + 1$. Then the nodes in $L_{\ell-1}$ represent elements in \mathcal{X} and those in L_ℓ represent elements in \mathcal{Y} . Recall that Z_ℓ corresponds to the element $z_{\ell'} \in \mathcal{Y}$ where $\ell' = \lceil \ell/2 \rceil$. Consider any $x_i \in \mathcal{X}$. We have three cases: (i) $z_{\ell'}$ is in exactly one of the sets $A_{x_i}^{\ell'-1}$ and $B_{x_i}^{\ell'-1}$, (ii) $z_{\ell'}$ is in neither of them, and (iii) $z_{\ell'}$ is in both, i.e., $t_{x_i}^{\ell'-1} = z_{\ell'}$. If ℓ is of the form $4a + 3$, we make the analogous arguments exchanging \mathcal{X} and \mathcal{Y} , replacing A and B by C and D , and x_i by y_i . We analyze each case.

By IH Inv. 3(d), the triple representing x_i in layer $\ell - 1$ had degree (d, d, d) before iteration $3\ell + 1$. After Z_ℓ is removed, the degrees of such a triple can be the following. In case (i), it becomes either $(d - 2, d, d)$ or $(d, d - 2, d)$ (in Figure 4, the triple $(v_{0,2,1}, v_{0,2,2}, v_{0,2,3})$ is of this type). This is because exactly one of the vertices $v_{\ell-1,i,1}$ and $v_{\ell-1,i,2}$ had edges to both $v_{\ell,i^*(\ell),1}$ and $v_{\ell,i^*(\ell),2}$, and the other had none. In case (ii), it remains (d, d, d) since neither $v_{\ell-1,i,1}$ nor $v_{\ell-1,i,2}$ had any edge to Z_ℓ . In case (iii), it becomes $(d - 2, d - 2, d)$ (in Figure 4, the triple $(v_{0,3,1}, v_{0,3,2}, v_{0,3,3})$ is of this type). This follows since both nodes $v_{\ell-1,i,1}$ and $v_{\ell-1,i,2}$ had edges to both $v_{\ell,i^*(\ell),1}$ and $v_{\ell,i^*(\ell),2}$.

For possible values of j , consider the nodes in layer L_j before iteration $3(\ell + 1) + 1$. From the above analysis, for $j = \ell - 1$, any node in L_j has degree $\geq d - 2$. Further, by IH Inv. 3(b), for $j = \ell$ or $r \leq \ell - 2$, any vertex $v \notin Z_\ell$ had $\deg(v) \geq d - 2$ before iteration $3\ell + 1$. Since these nodes cannot be affected by the removal of Z_ℓ , their degrees remain so. Therefore, we have shown that any vertex in layer L_j for $j \leq \ell = (\ell + 1) - 1$ has degree $\geq d - 2$, which means Inv. 2(b) holds for $\ell + 1$.

By IH Inv. 3(c), for an odd $r \geq \ell + 2$, any vertex in L_j had degree $d - 1$ before iteration $3\ell + 1$. Removal of Z_ℓ doesn't affect them and hence, their degrees remain so. Thus, Inv. 2(c) holds for $\ell + 1$. Finally, for an even $r \geq \ell + 1$, IH Inv. 3(d) says that a vertex v in L_r had degree d before iteration $3\ell + 1$. The deletion of Z_ℓ can only affect $Z_{\ell+1}$ among these nodes. So a vertex $v \notin Z_{\ell+1}$ in L_j still has degree d . Therefore, Inv. 2(d), and in fact, Inv. (2) holds for $\ell + 1$.

It only remains to show that Inv. (4) holds for $\ell + 1$. Since Inv. (2) holds for $\ell + 1$, we know that just before iteration $3(\ell + 1) + 1$, each node in $Z_{\ell+1}$ has degree $d - 3$, and any other node has degree at least $d - 2$. Hence, the premise of Claim 5.5 holds with H as the current graph,

$U = Z_{\ell+1}$, and $\delta = d - 3$. Therefore, by Claim 5.5, the first three iterations on H , i.e., iterations $(3(\ell + 1) + 1, 3(\ell + 1) + 2, 3(\ell + 1) + 3)$ delete $Z_{\ell+1}$ in some order, and during deletion, the degree of these nodes are $\leq d - 3$. Hence, Inv. (4) holds for $\ell + 1$.

Thus, we have proven that all the invariants hold for $\ell + 1$ irrespective of its parity. This completes the proof by induction. \square

We are now ready to prove Lemma 5.4.

Proof of Lemma 5.4. Indeed, we have two cases.

Case 1: $b(z_r) = 0$. We show that the min-degree peeling algorithm must peel a vertex of degree $\geq d - 2$ at some iteration. Then, Fact 3.15 implies that $\kappa(G)$ must be at least $d - 2$.

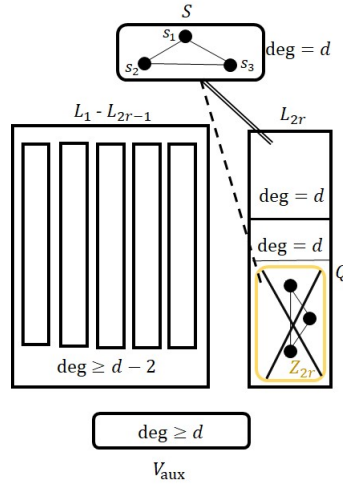

Figure 5: The graph after iteration $6r + 3$ for the case $b(z_r) = 0$. A double line between two sets of nodes signifies that all possible cross edges are present between them. A dashed line denotes that no edge is present between them.

By Lemma 5.6 Inv. (4), the first $6r + 3$ iterations of the peeling algorithm remove all the nodes in Z_0, Z_1, \dots, Z_{2r} . Consider the status of the graph after Z_{2r} is removed (see Figure 5). By the same lemma, all nodes in layers L_0, \dots, L_{2r} had degree $\geq d - 2$ before Z_{2r} was removed (i.e., just before iteration $6r + 1$). Since its removal cannot affect any of those nodes (in these layers it only had edges to Z_{2r-1} , which was previously removed), their degrees remain so. Now consider nodes in S . By Lemma 5.6 Inv. 1, just before iteration $6r + 1$, each of them had degree d . After the next 3 iterations remove Z_{2r} , their degrees remain d ; this is because they were not connected to Z_{2r} as $b(z_r) = 0$. Again, by the same invariant, just before iteration $6r + 1$, the nodes in V_{aux} had degree $\geq d + 3$. Hence, after iteration $6r + 3$, they must have degree $\geq d$. Therefore, the min-degree node in the current graph has degree $\geq d - 2$, implying that iteration $6r + 4$ of the peeling algorithm must peel a node of degree $\geq d - 2$.

Case 2: $b(z_r) = 1$. Define the ordering σ of nodes in G as follows. It agrees with the order in which the min-degree peeling algorithm peels the nodes until iteration $6r + 6$. Next, σ contains the chunk of the remaining nodes in layers L_0, \dots, L_{2r-1} . They are followed by the remaining nodes in layer L_{2r} . Finally we place the auxiliary nodes V_{aux} . The vertices in each of these last three chunks can be placed in any arbitrary order within the chunk. We show that $\text{odeg}_\sigma(v) \leq d - 3$ (see Definition 3.11) for each v .

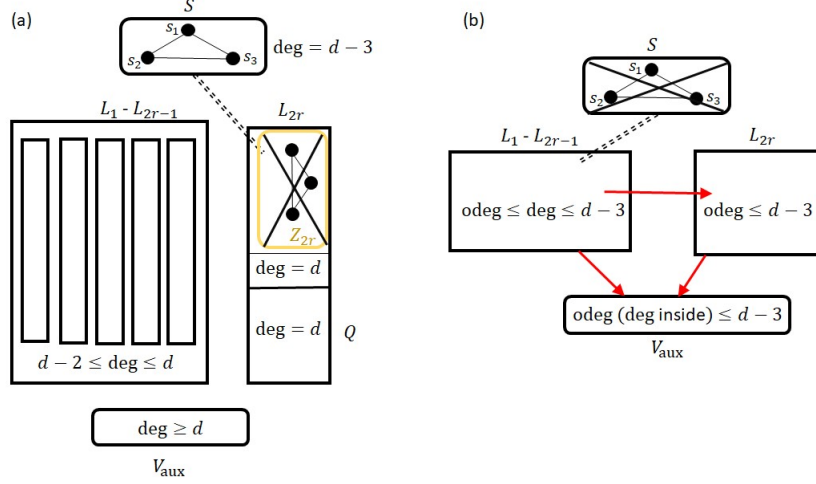

Figure 6: For the case $b(z_r) = 1$: (a) the graph after iteration $6r + 3$. Z_{2r} was deleted in the last three iterations and hence crossed out. (b) The oriented red edges show a $(d - 3)$ -ordering of the nodes remaining after iteration $6r + 6$. A dotted double line between two sets signifies that originally all cross edges were present between them.

As in the last case, by Inv. (4) of Lemma 5.6, the first $6r + 3$ iterations of the peeling algorithm remove all nodes in Z_0, Z_1, \dots, Z_{2r} . Further, each time such a node is removed, its degree in the remaining graph is at most $d - 3$. Again, by Inv. (1), just before iteration $6r + 1$, the nodes in S had degree d . When the next 3 iterations remove Z_{2r} (see Figure 6(a)), their degrees drop to $d - 3$ this is because all nodes in S were adjacent to all nodes in Z_{2r} as $b(z_r) = 1$. By the invariants in Lemma 5.6, all other remaining nodes have degree $\geq d - 2$. Hence, the premise of Claim 5.5 applies with H as the current graph, $U = S$, and $\delta = d - 3$. By Claim 5.5, the first three iterations on H , i.e., iterations $(6r + 4, 6r + 5, 6r + 6)$ remove the nodes in S , each having degree $\leq d - 3$ when deleted. Since σ agrees with the peeling algorithm until this iteration, and we showed that every vertex v until now has been removed while having degree $\leq d - 3$, it follows that $\text{odeg}_\sigma(v) \leq d - 3$ for each such v .

After S is removed (see Figure 6(b)), observe that all remaining nodes in layers L_0, \dots, L_{2r-1} have degree $\leq d - 3$ since they had degree $\leq d$ before the removal of S , and they were all adjacent to all three nodes in S . Hence, regardless of their order in σ , $\text{odeg}_\sigma(v) \leq d - 3$ for any such node v . If we remove these nodes from the graph, then each node in layer L_{2r} will have degree $\leq d - 3$ in the remaining graph: it initially had degree d , and now has lost at least its 3 neighbors in layer L_{2r-1} . Thus, $\text{odeg}_\sigma(v) \leq d - 3$ for each such node v .

Finally, the auxiliary nodes V_{aux} remain, and by Lemma 5.3, the induced subgraph $G[V_{\text{aux}}]$ has degree $\leq d - 3$. Therefore, $\text{odeg}_\sigma(v) \leq d - 3$ for any $v \in V_{\text{aux}}$ and we conclude that $\text{odeg}_\sigma(v) \leq d - 3$ for all $v \in V$. Hence, σ is a $(d - 3)$ -ordering of vertices in G . Then by Fact 3.13, we get that $\kappa(G) \leq d - 3$. \square

5.3 Completing the Reduction: Streaming to Communication Protocol

We now put things together and complete the reduction to prove Theorem 5.1. We restate the theorem here.

Theorem 5.1. *Given an integer k and an n -vertex graph G , any p -pass streaming algorithm that can check whether $\kappa(G) \leq k$ or not requires $\Omega(n^2/p^3 - (n \log n)/p)$ space.*

Proof. Suppose there is a p -pass S -space streaming algorithm \mathcal{A} that, given an integer k , outputs

YES if $\kappa(G) \leq k$ and NO if not. Then, given an instance of $\text{BMHPC}_{m,2p-1}$, the players P_A, P_B, P_C , and P_D run the following $(2p-1)$ -phase protocol. They collectively feed the graph $G = (V, E)$ as in Lemma 5.3 to \mathcal{A} as follows.

First note that the vertex set V is known to all the players. Further, the edge sets E_1, E_2, E_S are also input-independent and known to all players. In phase 1 of the protocol, P_C starts pass 1 of the algorithm \mathcal{A} and inserts the edges in these sets. She then adds the edges E_C which are completely determined by her input. Next, she sends the current state of \mathcal{A} along with all the vertex-degrees in the current graph to P_D . The player P_D continues the stream by adding the edges in E_D , which is determined by his input. Next, he sends the current state of \mathcal{A} along with the updated vertex-degrees of the current graph (which he can calculate from the edges he added and the information sent to him by P_C) to the player P_A . This ends phase 1.

In phase 2, P_A further extends the stream by adding the edges in E_A , which is given by her input. She sends the algorithm's state along with the updated node-degrees to P_B . The player P_B adds the edge set E_B and updates the degrees. Observe that the current graph has the edge set E' as defined above. From the degree information, P_B can now determine the edges E_{aux} to be added to set the target node-degrees (by Lemma 5.3). Hence, P_B adds those edges, which completes the first pass of \mathcal{A} on G . To end phase 2, P_B sends the current state of the algorithm to P_C . In phase 3, P_C starts pass 2 of the algorithm by inserting the same edges that she added in phase 1. They repeat the protocol as before for pass 2, except that they no longer communicate degree information since P_B already knows E_{aux} . Thus, the players can simulate one pass of \mathcal{A} using two phases of the communication protocol, except the last pass that requires just one phase. After the final pass of \mathcal{A} , the player P_B looks at the output given by the algorithm for $k = d - 3 = 6m(2p - 1) + 3m - 3$ and determines the answer to $\text{BMHPC}_{m,2p-1}$ (using Lemma 5.4).

Thus, the players can solve $\text{BMHPC}_{m,2p-1}$ using $2p - 1$ phases and $O(pS + n \log n)$ bits of communication. By Theorem 4.1, it follows that $pS \geq \Omega(m^2 - n \log n)$. Since $n = \Theta(mp)$ by Lemma 5.3, we get that $pS \geq \Omega(n^2/p^2 - n \log n)$, which implies that $S \geq \Omega(n^2/p^3 - (n \log n)/p)$. This completes the proof of the theorem. \square

We observe that the reductions for lexicographically-first maximal independent set (LFMIS) and s-t min-cut from HPC in [ACK19] have a similar layered graph, where the *same* HPC instance is repeated between alternate pairs of consecutive layers. Instead, we can reduce from MHPC as follows: similar to our reduction for degeneracy, we can make the successive pairs of layers encode the *distinct* “instances” of HPC that are given in a single instance of MHPC. Then, following very similar arguments as above, the reductions from MHPC to these problems go through and their streaming lower bounds are improved. Thus, we can prove Corollary 1.1. We skip the formal details.

6 Communication Upper Bounds

In this section, we will see a communication upper bound for computing the degeneracy of a graph exactly. The setting is as follows: Alice and Bob are respectively given *disjoint* edge sets E_A and E_B on the set of vertices V (known to both Alice and Bob), and wish to compute the degeneracy of the graph $G = (V, E_A \cup E_B)$. The main theorem of this section is:

Theorem 6.1. *There exists a deterministic communication protocol that, given an n -vertex graph G , computes the degeneracy $\kappa(G)$ using $O(n \log^3 n)$ bits of communication. Moreover, the protocol outputs a $\kappa(G)$ -ordering of the vertices of G , and a $\kappa(G)$ -core in G .*

We will focus on a decision version of the degeneracy problem, which we define in the lemma below:

Lemma 6.2. *There exists a deterministic communication protocol that given an n -vertex graph G and an integer k , decides whether the degeneracy $\kappa(G) \leq k$ using $O(n \log^2 n)$ bits of communication. Moreover, if the protocol accepts, it outputs a k -ordering of the vertices of G , and if it rejects, it outputs a $(k + 1)$ -core in G .*

For brevity, we will call the decision version of degeneracy defined in the lemma above $\text{DEGEN}_{n,k}$. Note that once we have a protocol for the decision problem, a protocol for the search variant follows via binary search.

Proof of Theorem 6.1. Alice and Bob can binary search for the minimum k such that G has degeneracy at most k (which is exactly $\kappa(G)$) using the protocol given by Lemma 6.2. Note that this incurs a multiplicative $\log n$ overhead in communication cost. Further, the protocol in the lemma also gives a $\kappa(G)$ -ordering, since it accepts the input $(G, \kappa(G))$. Finally, to obtain a $\kappa(G)$ -core, Alice and Bob can run the protocol in the lemma on the input $(G, \kappa(G) - 1)$. \square

In the rest of this section, we will prove Lemma 6.2. First, we show an easier (but more expensive) protocol that captures the main idea.

6.1 Warm-Up: An $\tilde{O}(n\sqrt{n})$ Communication Protocol

Recall the classical peeling algorithm, where one successively peels off the vertex of minimum degree to find a degeneracy ordering of G . We state a decision version of it below, which removes an arbitrary vertex of degree $\leq k$ in each step.

Algorithm 1. The Peeling Algorithm.

Input: A graph G , and an integer k .

Output: ACCEPT if G has degeneracy $\leq k$, REJECT otherwise.

1. While G is non-empty:
 - (a) If there is a vertex $v \in G$ of degree $\leq k$, remove v from G .
 - (b) Else output REJECT.
2. Output ACCEPT.

Note that in the ACCEPT case the k -ordering is simply the order the vertices were peeled in, and in the REJECT case, the $(k + 1)$ -core is the set of vertices remaining in G when there are no vertices of degree $\leq k$.

We want to somehow port this algorithm to the communication setting. The immediate problem is that Alice or Bob cannot compute a low degree vertex without any communication after a vertex is removed. The naive way to get around this is to send the updated degree of each vertex after each deletion, but this can cost $\Omega(n^2)$ communication. Instead, we observe that we only need to update the degrees of a remaining vertex if it is not too large:

Observation 6.3. *If $\deg(u) > k + \sqrt{n}$ at some step of the peeling algorithm, then u cannot be deleted in the next \sqrt{n} steps, since its degree falls by at most 1 per step.*

Hence we have the following algorithm:

1. Compute the set $S = \{u \in V \mid \deg(u) > k + \sqrt{n}\}$ of *safe* vertices, and set it aside.

2. Perform \sqrt{n} iterations of the peeling algorithm, while updating the degree of a neighbor u of a deleted vertex only if $u \notin S$ and $\deg(u) > k$.
3. If the graph is non-empty, go to step 1.

Let $N_A(u)$ and $\deg_A(u)$ denote the neighborhood and degree of u within (V, E_A) (and similarly $N_B(u)$ and $\deg_B(u)$ for E_B). We provide an implementation of the algorithm above in a communication protocol; the sets D and L hold vertices that are ready to *delete*, and *low* degree respectively.

Algorithm 2. The $\tilde{O}(n\sqrt{n})$ communication protocol for $\text{DEGEN}_{n,k}$.

Input: Alice and Bob get disjoint edge sets E_A and E_B respectively, and both players get an integer k .

Output: ACCEPT if $G = E_A \cup E_B$ has degeneracy $\leq k$, REJECT otherwise.

1. Alice and Bob send $\deg_A(u)$ and $\deg_B(u)$ respectively for every vertex $u \in V(G)$, so they can then compute:
 - $D \leftarrow \{u \in G \mid \deg(u) \leq k\}$.
 - $L \leftarrow \{u \in G \mid k + 1 \leq \deg(u) \leq k + \sqrt{n}\}$.
 - $S \leftarrow V(G) \setminus (D \cup L)$.
2. For \sqrt{n} iterations:
 - (a) If D is empty, output REJECT.
 - (b) Let v be any vertex in D . To remove v from G :
 - (c) Alice and Bob send $N_A(v) \cap L$ and $N_B(v) \cap L$ respectively.
 - (d) Hence they can update $\deg(u)$ for all $u \in L$.
 - (e) If $\deg(u) < k + 1$ for any $u \in L$, Alice and Bob move it to D .
3. If G is non-empty, go to Step 1.
4. Output ACCEPT.

Note that the proofs (a k -ordering of the vertices in the ACCEPT case, and a $(k + 1)$ -core in the REJECT case) fall out of the protocol exactly as before. The correctness of this protocol follows from Observation 6.3; we omit the proof here since it is subsumed by the next section. To see that it only uses $\tilde{O}(n\sqrt{n})$ bits of communication, we observe that:

- Sending the degree of all vertices costs $O(n \log n)$ bits, and we do this at most \sqrt{n} times.
- Once a vertex is in D , no communication is spent for updating its own degree.
- Each vertex in L features at most \sqrt{n} times in the neighborhood of a deleted vertex before it is moved to D , costing $O(\sqrt{n} \log n)$ bits per vertex.

Hence the total communication cost of the protocol is $O(n\sqrt{n} \log n)$.

6.2 An $\tilde{O}(n)$ Communication Protocol

There are two changes from the previous protocol:

1. Instead of a single safe set of vertices, we have $O(\log n)$ safe sets corresponding to exponentially increasing gaps between the degree and k . More precisely, we define the set S_i for $i \in [\log n]$ such that whenever Alice and Bob compute $\deg(u)$ for some vertex u , they place it in S_i if $k + 2^{i-1} \leq \deg(u) < k + 2^i$.
2. Instead of counting a global number of iterations until the safe vertices are updated, we track each vertex individually. Concretely, suppose $\deg(u) \geq k + \ell$. Then u cannot be deleted until $\deg_A(u)$ or $\deg_B(u)$ falls by at least $\ell/2$.

The upshot of the two changes above is that for $u \in S_i$ Alice and Bob do not have to update $\deg(u)$ until $\deg_A(u)$ or $\deg_B(u)$ falls by at least 2^{i-2} . We can now state the algorithm. As before, the set D holds all vertices which are ready for deletion.

Algorithm 3. The $\tilde{O}(n)$ communication protocol for $\text{DEGEN}_{n,k}$.

Input: Alice and Bob get disjoint edge sets E_A and E_B respectively, and both players get an integer k .

Output: ACCEPT if $G = E_A \cup E_B$ has degeneracy $\leq k$, REJECT otherwise.

1. Alice and Bob send $\deg_A(u)$ and $\deg_B(u)$ respectively for every vertex $u \in V(G)$, so they can then compute:
 - $D \leftarrow \{u \in G \mid \deg(u) \leq k\}$.
 - $S_i \leftarrow \{u \in G \mid k + 2^{i-1} \leq \deg(u) < k + 2^i\}$, for each $i \in [\log n]$.
2. While G is non-empty:
 - (a) If D is empty, output REJECT.
 - (b) Let v be any vertex in D . To remove v from G :
 - (c) For each $i \in [\log n]$, and each $u \in S_i$, if $\deg_A(u)$ or $\deg_B(u)$ has fallen by $\geq 2^{i-2}$ since it was last communicated, Alice sends $\deg_A(u)$ and Bob sends $\deg_B(u)$, hence allowing them to update $\deg(u)$.
 - (d) For all vertices updated in the previous step, Alice and Bob place them in the correct S_i (or D).
3. Output ACCEPT.

To wrap up, we prove that the algorithm above is correct, and uses $\tilde{O}(n)$ space.

Proof of Lemma 6.2. To prove that this protocol is correct, we argue that:

- All vertices have degree $\leq k$ when they are removed, which implies that if the protocol outputs ACCEPT, $\kappa(G) \leq k$. This is immediate because we only move vertices to D when we know their current degree exactly, and it is $\leq k$.
- Any vertex u with degree $\leq k$ is placed in D , which implies that if $\kappa(G) \leq k$, then the protocol outputs ACCEPT. Suppose towards a contradiction that u was placed in the set S_i when its degree was updated for the final time. This means that $\deg(u)$ was at least $k + 2^{i-1}$. But now for $\deg(u)$ to fall below $k + 1$, at least one of $\deg_A(u)$ or $\deg_B(u)$ must fall by $\geq 2^{i-2}$ (otherwise $\deg(u)$ falls by less than 2^{i-1}). Hence $\deg(u)$ was updated again following the final update, and we have a contradiction.

Next, we argue that this protocol uses only $\tilde{O}(n)$ communication.

- As before, the initial setup uses only $O(\log n)$ bits per vertex.
- While in S_i , a vertex can have its degree updated at most twice before it falls below $k + 2^{i-1}$, and is hence dropped from S_i . Since there are only $\log n$ sets S_i , and a vertex can never gain degree, we only update its degree $O(\log n)$ times before it falls into D , spending $O(\log^2 n)$ bits overall.

Hence, in total, the protocol uses only $O(n \log^2 n)$ bits of communication. \square

Acknowledgements

The first named author would like to thank Yu Chen and Sanjeev Khanna for their collaboration in [ACK19] that was the starting point of this project and Madhu Sudan for helpful conversations.

Sepehr Assadi is supported in part by a Sloan Research Fellowship, an NSERC Discovery Grant, a University of Waterloo startup grant, and a Faculty of Math Research Chair grant.

Prantar Ghosh is supported in part by NSF under award 1918989. Part of this work was done while he was at DIMACS, Rutgers University, supported in part by a grant (820931) to DIMACS from the Simons Foundation.

Bruno Loff is funded by the European Union (ERC, HOFGA, 101041696). Views and opinions expressed are however those of the author(s) only and do not necessarily reflect those of the European Union or the European Research Council. Neither the European Union nor the granting authority can be held responsible for them. He was also supported by FCT through the LASIGE Research Unit, ref. UIDB/00408/2020 and ref. UIDP/00408/2020, and by CMAFcIO, FCT Project UIDB/04561/2020, <https://doi.org/10.54499/UIDB/04561/2020>.

Parth Mittal is supported by a David R. Cheriton Graduate Scholarship and Sepehr Assadi's Sloan Research Fellowship, an NSERC Discovery grant, and a startup grant from University of Waterloo.

Sagnik Mukhopadhyay is partially funded by the UKRI New Investigator Award, ref. [EP/X03805X/1](https://doi.org/10.1017/X03805X/1).

References

- [A17] Sepehr Assadi A. Tight space-approximation tradeoff for the multi-pass streaming set cover problem. In *Proceedings of the 36th ACM SIGMOD-SIGACT-SIGAI Symposium on Principles of Database Systems, PODS 2017, Chicago, IL, USA, May 14-19, 2017*, pages 321–335, 2017. 1
- [A22] Sepehr Assadi A. A two-pass (conditional) lower bound for semi-streaming maximum matching. In Joseph (Seffi) Naor and Niv Buchbinder, editors, *Proceedings of the 2022 ACM-SIAM Symposium on Discrete Algorithms, SODA 2022, Virtual Conference / Alexandria, VA, USA, January 9 - 12, 2022*, pages 708–742. SIAM, 2022. 2
- [AA20] Noga Alon and Sepehr Assadi. Palette sparsification beyond $(\Delta+1)$ vertex coloring. In Jaroslav Byrka and Raghv Meka, editors, *Approximation, Randomization, and Combinatorial Optimization. Algorithms and Techniques, APPROX/RANDOM 2020, August 17-19, 2020, Virtual Conference*, volume 176 of *LIPICs*, pages 6:1–6:22. Schloss Dagstuhl - Leibniz-Zentrum für Informatik, 2020. 3

- [ACK19] Sepehr Assadi, Yu Chen, and Sanjeev Khanna. Polynomial pass lower bounds for graph streaming algorithms. In *STOC*, pages 265–276. ACM, 2019. [1](#), [2](#), [3](#), [4](#), [5](#), [6](#), [10](#), [15](#), [16](#), [17](#), [27](#), [29](#), [42](#), [46](#), [55](#)
- [ACKP21] Amir Abboud, Keren Censor-Hillel, Seri Khoury, and Ami Paz. Smaller cuts, higher lower bounds. *ACM Trans. Algorithms*, 17(4):30:1–30:40, 2021. [1](#)
- [AD21] Sepehr Assadi and Aditi Dudeja. A simple semi-streaming algorithm for global minimum cuts. In *SOSA*, pages 172–180. SIAM, 2021. [1](#)
- [ADBV05] J. Ignacio Alvarez-Hamelin, Luca Dall’Asta, Alain Barrat, and Alessandro Vespignani. Large scale networks fingerprinting and visualization using the k-core decomposition. In *Advances in Neural Information Processing Systems 18 [Neural Information Processing Systems, NIPS 2005, December 5-8, 2005, Vancouver, British Columbia, Canada]*, pages 41–50, 2005. [3](#)
- [AJJ⁺22] Sepehr Assadi, Arun Jambulapati, Yujia Jin, Aaron Sidford, and Kevin Tian. Semi-streaming bipartite matching in fewer passes and optimal space. In *SODA*, pages 627–669. SIAM, 2022. [1](#)
- [AKSY20] Sepehr Assadi, Gillat Kol, Raghuvansh Saxena, and Huacheng Yu. Multi-pass graph streaming lower bounds for cycle counting, max-cut, matching size, and other problems. In *61st Annual IEEE Symposium on Foundations of Computer Science, FOCS (to appear)*, 2020. [2](#)
- [AKZ22] Sepehr Assadi, Gillat Kol, and Zhijun Zhang. Rounds vs communication tradeoffs for maximal independent sets. In *63rd IEEE Annual Symposium on Foundations of Computer Science, FOCS 2022, Denver, CO, USA, October 31 - November 3, 2022*, pages 1193–1204. IEEE, 2022. [2](#)
- [AN21] Sepehr Assadi and Vishvajeet N. Graph streaming lower bounds for parameter estimation and property testing via a streaming XOR lemma. In Samir Khuller and Virginia Vassilevska Williams, editors, *STOC ’21: 53rd Annual ACM SIGACT Symposium on Theory of Computing, Virtual Event, Italy, June 21-25, 2021*, pages 612–625. ACM, 2021. [2](#)
- [AR20] Sepehr Assadi and Ran Raz. Near-quadratic lower bounds for two-pass graph streaming algorithms. In *FOCS*, pages 342–353. IEEE, 2020. [1](#), [2](#), [5](#), [6](#), [7](#), [10](#), [22](#), [25](#)
- [AYZ97] Noga Alon, Raphael Yuster, and Uri Zwick. Finding and counting given length cycles. *Algorithmica*, 17(3):209–223, 1997. [3](#)
- [BBCR10] Boaz Barak, Mark Braverman, Xi Chen, and Anup Rao. How to compress interactive communication. In *Proceedings of the 42nd ACM Symposium on Theory of Computing, STOC 2010, 5-8 June 2010*, pages 67–76, 2010. [59](#)
- [BCD⁺19] Nir Bachrach, Keren Censor-Hillel, Michal Dory, Yuval Efron, Dean Leitersdorf, and Ami Paz. Hardness of distributed optimization. In Peter Robinson and Faith Ellen, editors, *Proceedings of the 2019 ACM Symposium on Principles of Distributed Computing, PODC 2019, Toronto, ON, Canada, July 29 - August 2, 2019*, pages 238–247. ACM, 2019. [1](#)

- [BCG20] Suman K. Bera, Amit Chakrabarti, and Prantar Ghosh. Graph coloring via degeneracy in streaming and other space-conscious models. In *47th International Colloquium on Automata, Languages, and Programming, ICALP 2020, July 8-11, 2020, Saarbrücken, Germany (Virtual Conference)*, pages 11:1–11:21, 2020. [3](#)
- [BEO⁺13] Mark Braverman, Faith Ellen, Rotem Oshman, Toniann Pitassi, and Vinod Vaikuntanathan. A tight bound for set disjointness in the message-passing model. In *54th Annual IEEE Symposium on Foundations of Computer Science, FOCS 2013, 26-29 October, 2013, Berkeley, CA, USA*, pages 668–677, 2013. [59](#)
- [BGKV14] Francesco Bonchi, Francesco Gullo, Andreas Kaltenbrunner, and Yana Volkovich. Core decomposition of uncertain graphs. In Sofus A. Macskassy, Claudia Perlich, Jure Leskovec, Wei Wang, and Rayid Ghani, editors, *The 20th ACM SIGKDD International Conference on Knowledge Discovery and Data Mining, KDD '14, New York, NY, USA - August 24 - 27, 2014*, pages 1316–1325. ACM, 2014. [3](#)
- [BHNT15] Sayan Bhattacharya, Monika Henzinger, Danupon Nanongkai, and Charalampos E. Tsourakakis. Space- and time-efficient algorithm for maintaining dense subgraphs on one-pass dynamic streams. In *Proceedings of the Forty-Seventh Annual ACM on Symposium on Theory of Computing, STOC 2015, Portland, OR, USA, June 14-17, 2015*, pages 173–182, 2015. [3](#)
- [BJKS02] Ziv Bar-Yossef, T. S. Jayram, Ravi Kumar, and D. Sivakumar. An information statistics approach to data stream and communication complexity. In *43rd Symposium on Foundations of Computer Science (FOCS 2002), 16-19 November 2002, Proceedings*, pages 209–218, 2002. [59](#), [61](#)
- [BKS02] Ziv Bar-Yossef, Ravi Kumar, and D. Sivakumar. Reductions in streaming algorithms, with an application to counting triangles in graphs. In *Proceedings of the Thirteenth Annual ACM-SIAM Symposium on Discrete Algorithms, January 6-8, 2002, San Francisco, CA, USA.*, pages 623–632, 2002. [1](#)
- [BKV12] Bahman Bahmani, Ravi Kumar, and Sergei Vassilvitskii. Densest subgraph in streaming and mapreduce. *PVLDB*, 5(5):454–465, 2012. [3](#)
- [BR11] Mark Braverman and Anup Rao. Information equals amortized communication. In *IEEE 52nd Annual Symposium on Foundations of Computer Science, FOCS 2011, October 22-25, 2011*, pages 748–757, 2011. [59](#), [60](#)
- [BvdBE⁺22] Joakim Blikstad, Jan van den Brand, Yuval Efron, Sagnik Mukhopadhyay, and Danupon Nanongkai. Nearly optimal communication and query complexity of bipartite matching. In *FOCS*, pages 1174–1185. IEEE, 2022. [1](#), [2](#)
- [CFHT20] Yi-Jun Chang, Martin Farach-Colton, Tsan-sheng Hsu, and Meng-Tsung Tsai. Streaming complexity of spanning tree computation. In *37th International Symposium on Theoretical Aspects of Computer Science, STACS 2020, March 10-13, 2020, Montpellier, France*, pages 34:1–34:19, 2020. [1](#)
- [CGMV20] Amit Chakrabarti, Prantar Ghosh, Andrew McGregor, and Sofya Vorotnikova. Vertex ordering problems in directed graph streams. In *Proceedings of the 2020 ACM-SIAM Symposium on Discrete Algorithms, SODA 2020, Salt Lake City, UT, USA, January 5-8, 2020*, pages 1786–1802, 2020. [1](#), [2](#)

- [Cha00] Moses Charikar. Greedy approximation algorithms for finding dense components in a graph. In Klaus Jansen and Samir Khuller, editors, *Approximation Algorithms for Combinatorial Optimization, Third International Workshop, APPROX 2000, Saarbrücken, Germany, September 5-8, 2000, Proceedings*, volume 1913 of *Lecture Notes in Computer Science*, pages 84–95. Springer, 2000. [3](#)
- [CKP⁺21a] Lijie Chen, Gillat Kol, Dmitry Paramonov, Raghuvansh R. Saxena, Zhao Song, and Huacheng Yu. Almost optimal super-constant-pass streaming lower bounds for reachability. In Samir Khuller and Virginia Vassilevska Williams, editors, *STOC '21: 53rd Annual ACM SIGACT Symposium on Theory of Computing, Virtual Event, Italy, June 21-25, 2021*, pages 570–583. ACM, 2021. [1](#), [2](#)
- [CKP⁺21b] Lijie Chen, Gillat Kol, Dmitry Paramonov, Raghuvansh R. Saxena, Zhao Song, and Huacheng Yu. Near-optimal two-pass streaming algorithm for sampling random walks over directed graphs. In Nikhil Bansal, Emanuela Merelli, and James Worrell, editors, *48th International Colloquium on Automata, Languages, and Programming, ICALP 2021, July 12-16, 2021, Glasgow, Scotland (Virtual Conference)*, volume 198 of *LIPICs*, pages 52:1–52:19. Schloss Dagstuhl - Leibniz-Zentrum für Informatik, 2021. [2](#)
- [CKP⁺23] Lijie Chen, Gillat Kol, Dmitry Paramonov, Raghuvansh R. Saxena, Zhao Song, and Huacheng Yu. Towards multi-pass streaming lower bounds for optimal approximation of max-cut. In Nikhil Bansal and Viswanath Nagarajan, editors, *Proceedings of the 2023 ACM-SIAM Symposium on Discrete Algorithms, SODA 2023, Florence, Italy, January 22-25, 2023*, pages 878–924. SIAM, 2023. [2](#)
- [CSWY01] Amit Chakrabarti, Yaoyun Shi, Anthony Wirth, and Andrew Chi-Chih Yao. Informational complexity and the direct sum problem for simultaneous message complexity. In *42nd Annual Symposium on Foundations of Computer Science, FOCS 2001, 14-17 October 2001*, pages 270–278, 2001. [59](#)
- [CT06] Thomas M. Cover and Joy A. Thomas. *Elements of information theory (2. ed.)*. Wiley, 2006. [57](#)
- [CZL⁺20] Deming Chu, Fan Zhang, Xuemin Lin, Wenjie Zhang, Ying Zhang, Yinglong Xia, and Chenyi Zhang. Finding the best k in core decomposition: A time and space optimal solution. In *36th IEEE International Conference on Data Engineering, ICDE 2020, Dallas, TX, USA, April 20-24, 2020*, pages 685–696. IEEE, 2020. [3](#)
- [DBS17] Laxman Dhulipala, Guy E. Blelloch, and Julian Shun. Julianne: A framework for parallel graph algorithms using work-efficient bucketing. In Christian Scheideler and Mohammad Taghi Hajiaghayi, editors, *Proceedings of the 29th ACM Symposium on Parallelism in Algorithms and Architectures, SPAA 2017, Washington DC, USA, July 24-26, 2017*, pages 293–304. ACM, 2017. [3](#)
- [DBS18] Laxman Dhulipala, Guy E. Blelloch, and Julian Shun. Theoretically efficient parallel graph algorithms can be fast and scalable. In Christian Scheideler and Jeremy T. Fineman, editors, *Proceedings of the 30th on Symposium on Parallelism in Algorithms and Architectures, SPAA 2018, Vienna, Austria, July 16-18, 2018*, pages 393–404. ACM, 2018. [3](#)
- [DNO19] Shahar Dobzinski, Noam Nisan, and Sigal Oren. Economic efficiency requires interaction. *Games Econ. Behav.*, 118:589–608, 2019. [2](#)

- [EH66] Paul Erdős and András Hajnal. On chromatic number of graphs and set-systems. *Acta Math. Acad. Sci. Hungar.*, 17(61-99):1, 1966. [3](#)
- [ELM18] Hossein Esfandiari, Silvio Lattanzi, and Vahab S. Mirrokni. Parallel and streaming algorithms for k-core decomposition. In Jennifer G. Dy and Andreas Krause, editors, *Proceedings of the 35th International Conference on Machine Learning, ICML 2018, Stockholmsmässan, Stockholm, Sweden, July 10-15, 2018*, volume 80 of *Proceedings of Machine Learning Research*, pages 1396–1405. PMLR, 2018. [3](#)
- [FHW12] Silvio Frischknecht, Stephan Holzer, and Roger Wattenhofer. Networks cannot compute their diameter in sublinear time. In Yuval Rabani, editor, *Proceedings of the Twenty-Third Annual ACM-SIAM Symposium on Discrete Algorithms, SODA 2012, Kyoto, Japan, January 17-19, 2012*, pages 1150–1162. SIAM, 2012. [1](#)
- [FKM⁺05] Joan Feigenbaum, Sampath Kannan, Andrew McGregor, Siddharth Suri, and Jian Zhang. On graph problems in a semi-streaming model. *Theor. Comput. Sci.*, 348(2-3):207–216, 2005. [1](#)
- [FT14] Martin Farach-Colton and Meng-Tsung Tsai. Computing the degeneracy of large graphs. In Alberto Pardo and Alfredo Viola, editors, *LATIN 2014: Theoretical Informatics - 11th Latin American Symposium, Montevideo, Uruguay, March 31 - April 4, 2014. Proceedings*, volume 8392 of *Lecture Notes in Computer Science*, pages 250–260. Springer, 2014. [3](#)
- [FT16] Martin Farach-Colton and Meng-Tsung Tsai. Tight approximations of degeneracy in large graphs. In *LATIN 2016: Theoretical Informatics - 12th Latin American Symposium, Ensenada, Mexico, April 11-15, 2016, Proceedings*, pages 429–440, 2016. [3](#)
- [GBGL20] Edoardo Galimberti, Francesco Bonchi, Francesco Gullo, and Tommaso Lanciano. Core decomposition in multilayer networks: Theory, algorithms, and applications. *ACM Trans. Knowl. Discov. Data*, 14(1):11:1–11:40, 2020. [3](#)
- [GLM19] Mohsen Ghaffari, Silvio Lattanzi, and Slobodan Mitrovic. Improved parallel algorithms for density-based network clustering. In Kamalika Chaudhuri and Ruslan Salakhutdinov, editors, *Proceedings of the 36th International Conference on Machine Learning, ICML 2019, 9-15 June 2019, Long Beach, California, USA*, volume 97 of *Proceedings of Machine Learning Research*, pages 2201–2210. PMLR, 2019. [3](#)
- [GO13] Venkatesan Guruswami and Krzysztof Onak. Superlinear lower bounds for multipass graph processing. In *Proceedings of the 28th Conference on Computational Complexity, CCC 2013, K.lo Alto, California, USA, 5-7 June, 2013*, pages 287–298, 2013. [1](#)
- [HSSW12] Magnús M. Halldórsson, Xiaoming Sun, Mario Szegedy, and Chengyu Wang. Streaming and communication complexity of clique approximation. In *Automata, Languages, and Programming - 39th International Colloquium, ICALP 2012, Warwick, UK, July 9-13, 2012, Proceedings, Part I*, pages 449–460, 2012. [1](#)
- [IKL⁺12] Gábor Ivanyos, Hartmut Klauck, Troy Lee, Miklos Santha, and Ronald de Wolf. New bounds on the classical and quantum communication complexity of some graph properties. In *FSTTCS*, volume 18 of *LIPIcs*, pages 148–159. Schloss Dagstuhl - Leibniz-Zentrum für Informatik, 2012. [2](#)

- [JKS03] T. S. Jayram, Ravi Kumar, and D. Sivakumar. Two applications of information complexity. In *STOC*, pages 673–682. ACM, 2003. [6](#), [10](#), [15](#)
- [KBVT15] Wissam Khaouid, Marina Barsky, S. Venkatesh, and Alex Thomo. K-core decomposition of large networks on a single PC. *Proc. VLDB Endow.*, 9(1):13–23, 2015. [3](#)
- [Kla00] Hartmut Klauck. On quantum and probabilistic communication: Las vegas and one-way protocols. In *32nd Annual ACM Symposium on Theory of Computing (STOC)*, pages 644–651, 2000. [6](#)
- [KN97] Eyal Kushilevitz and Noam Nisan. *Communication complexity*. Cambridge University Press, 1997. [59](#)
- [KPP16] Tsvi Kopelowitz, Seth Pettie, and Ely Porat. Higher lower bounds from the 3sum conjecture. In Robert Krauthgamer, editor, *Proceedings of the Twenty-Seventh Annual ACM-SIAM Symposium on Discrete Algorithms, SODA 2016, Arlington, VA, USA, January 10-12, 2016*, pages 1272–1287. SIAM, 2016. [1](#)
- [KPSY23] Gillat Kol, Dmitry Paramonov, Raghuvansh R. Saxena, and Huacheng Yu. Characterizing the multi-pass streaming complexity for solving boolean csps exactly. In Yael Tauman Kalai, editor, *14th Innovations in Theoretical Computer Science Conference, ITCS 2023, January 10-13, 2023, MIT, Cambridge, Massachusetts, USA*, volume 251 of *LIPICs*, pages 80:1–80:15. Schloss Dagstuhl - Leibniz-Zentrum für Informatik, 2023. [1](#), [2](#)
- [LJS19] Yang P. Liu, Arun Jambulapati, and Aaron Sidford. Parallel reachability in almost linear work and square root depth. In David Zuckerman, editor, *60th IEEE Annual Symposium on Foundations of Computer Science, FOCS 2019, Baltimore, Maryland, USA, November 9-12, 2019*, pages 1664–1686. IEEE Computer Society, 2019. [1](#)
- [LSY⁺22] Quanquan C. Liu, Jessica Shi, Shangdi Yu, Laxman Dhulipala, and Julian Shun. Parallel batch-dynamic algorithms for k-core decomposition and related graph problems. In Kunal Agrawal and I-Ting Angelina Lee, editors, *SPAA '22: 34th ACM Symposium on Parallelism in Algorithms and Architectures, Philadelphia, PA, USA, July 11 - 14, 2022*, pages 191–204. ACM, 2022. [3](#)
- [LWSX18] Chao Li, Li Wang, Shiwen Sun, and Chengyi Xia. Identification of influential spreaders based on classified neighbors in real-world complex networks. *Appl. Math. Comput.*, 320:512–523, 2018. [3](#)
- [LZZ⁺19] Conggai Li, Fan Zhang, Ying Zhang, Lu Qin, Wenjie Zhang, and Xuemin Lin. Efficient progressive minimum k-core search. *Proc. VLDB Endow.*, 13(3):362–375, 2019. [3](#)
- [MB83] David W. Matula and Leland L. Beck. Smallest-last ordering and clustering and graph coloring algorithms. *J. ACM*, 30(3):417–427, 1983. [3](#), [13](#)
- [McG14] Andrew McGregor. Graph stream algorithms: a survey. *SIGMOD Rec.*, 43(1):9–20, 2014. [1](#)
- [MN20] Sagnik Mukhopadhyay and Danupon Nanongkai. Weighted min-cut: sequential, cut-query, and streaming algorithms. In *STOC*, pages 496–509. ACM, 2020. [1](#)

- [MTVV15] Andrew McGregor, David Tench, Sofya Vorotnikova, and Hoa T. Vu. Densest subgraph in dynamic graph streams. In *Mathematical Foundations of Computer Science 2015 - 40th International Symposium, MFCS 2015, Milan, Italy, August 24-28, 2015, Proceedings, Part II*, pages 472–482, 2015. [3](#)
- [NW91] Noam Nisan and Avi Wigderson. Rounds in communication complexity revisited. In *Proceedings of the 23rd Annual ACM Symposium on Theory of Computing, May 5-8, 1991, New Orleans, Louisiana, USA*, pages 419–429, 1991. [6](#)
- [NW93] Noam Nisan and Avi Wigderson. Rounds in communication complexity revisited. *SIAM J. Comput.*, 22(1):211–219, 1993. [6](#), [14](#), [17](#)
- [PRV99] Stephen Ponzio, Jaikumar Radhakrishnan, and Srinivasan Venkatesh. The communication complexity of pointer chasing: Applications of entropy and sampling. In *Proceedings of the Thirty-First Annual ACM Symposium on Theory of Computing, May 1-4, 1999, Atlanta, Georgia, USA*, pages 602–611, 1999. [6](#), [14](#)
- [PS84] Christos H. Papadimitriou and Michael Sipser. Communication complexity. *J. Comput. Syst. Sci.*, 28(2):260–269, 1984. [1](#)
- [Raz92] Alexander A. Razborov. On the distributional complexity of disjointness. *Theor. Comput. Sci.*, 106(2):385–390, 1992. [10](#)
- [RSW18] Aviad Rubinfeld, Tselil Schramm, and S. Matthew Weinberg. Computing exact minimum cuts without knowing the graph. In *ITCS*, volume 94 of *LIPICs*, pages 39:1–39:16. Schloss Dagstuhl - Leibniz-Zentrum für Informatik, 2018. [1](#)
- [RW13] Liam Roditty and Virginia Vassilevska Williams. Fast approximation algorithms for the diameter and radius of sparse graphs. In Dan Boneh, Tim Roughgarden, and Joan Feigenbaum, editors, *Symposium on Theory of Computing Conference, STOC’13, Palo Alto, CA, USA, June 1-4, 2013*, pages 515–524. ACM, 2013. [1](#)
- [SGJ⁺13] Ahmet Erdem Sariyüce, Bugra Gedik, Gabriela Jacques-Silva, Kun-Lung Wu, and Ümit V. Çatalyürek. Streaming algorithms for k-core decomposition. *Proc. VLDB Endow.*, 6(6):433–444, 2013. [3](#)
- [Yao79] Andrew Chi-Chih Yao. Some complexity questions related to distributive computing (preliminary report). In *Proceedings of the 11th Annual ACM Symposium on Theory of Computing, April 30 - May 2, 1979, Atlanta, Georgia, USA*, pages 209–213, 1979. [59](#)
- [Yeh20] Amir Yehudayoff. Pointer chasing via triangular discrimination. *Comb. Probab. Comput.*, 29(4):485–494, 2020. [5](#), [6](#), [13](#), [14](#), [15](#), [17](#), [54](#)

A Sampling Bounds

Recall the Chernoff bound:

Proposition A.1. *Let X_1, \dots, X_n be independent random variables with values in $[0, 1]$ and $X = \sum_i X_i$. Then:*

- **Additive form:** For any $b \geq 0$, $\Pr[|X - \mathbb{E}[X]| \geq b] \leq 2 \cdot \exp\left(-\frac{b^2}{2n}\right)$,
- **Multiplicative form:** For $0 \leq \delta \leq 1$, $\Pr[|X - \mathbb{E}[X]| \geq (1 + \delta)\mathbb{E}[X]] \leq \exp\left(-\frac{\delta^2 \mathbb{E}[X]}{3}\right)$.

Now suppose we are allowed to repeatedly sample from an unknown Bernoulli distribution μ . We know that μ either has acceptance probability p or acceptance probability q . We wish to determine which is the case, via some method that may err with probability γ . Suppose that, for some $1 \geq \alpha, \beta > 0$, $p \leq \alpha$, whereas $q \geq (1 + \beta)\alpha$. We may then draw

$$k = k(\alpha, \beta, \gamma) = \left\lceil \frac{48}{\alpha\beta^2} \ln\left(\frac{1}{\gamma}\right) \right\rceil$$

samples X_1, \dots, X_k from μ , and choose the threshold

$$\tau = \tau(\alpha, \beta, \gamma) = \alpha \cdot \left(1 + \frac{\beta}{4}\right) \cdot k$$

It now follows, from the multiplicative form of the Chernoff bound (Proposition A.1), that

$$\Pr\left[\sum_i X_i \geq \tau\right] = \Pr\left[\sum_i X_i \geq \alpha k \left(1 + \frac{\beta}{4}\right)\right] \leq \exp\left(-\frac{\beta^2}{48} \alpha k\right) \leq \gamma.$$

Now, whenever $\beta \in [0, 1]$, we have $1 + \frac{\beta}{4} \leq (1 + \beta)(1 - \frac{\beta}{4})$, and so, if the acceptance probability is $q \geq \alpha(1 + \beta)$, then

$$\begin{aligned} \Pr\left[\sum_i X_i \leq \tau\right] &= \Pr\left[\sum_i X_i \leq \alpha k \left(1 + \frac{\beta}{4}\right)\right] \leq \Pr\left[\sum_i X_i \leq \alpha(1 + \beta)k \left(1 - \frac{\beta}{4}\right)\right] \\ &\leq \exp\left(-\frac{\beta^2}{48} \alpha(1 + \beta)k\right) \leq \gamma. \end{aligned}$$

B Proof of Propositions Regarding Triangular Discrimination

Proposition 3.8. $0 \leq \frac{\|\mu - \nu\|_1^2}{8} \leq \Lambda(\mu, \nu) \leq \frac{\|\mu - \nu\|_1}{2} \leq 1$.

Proof. To see the lower bound on $\Lambda(\mu, \nu)$:

$$\frac{\|\mu - \nu\|_1}{2} = \sum_{x:\mu(x) > \nu(x)} (\mu(x) - \nu(x)) = \sum_{x:\mu(x) > \nu(x)} \frac{(\mu(x) - \nu(x))^2}{\sqrt{\mu(x) + \nu(x)}} \stackrel{(*)}{\leq} \sqrt{2\Lambda(\mu, \nu)}.$$

Here (*) follows from Cauchy-Schwarz. To see the upper bound:

$$\Lambda(\mu, \nu) = \sum_{x:\mu(x) > \nu(x)} \frac{(\mu(x) - \nu(x))^2}{\mu(x) + \nu(x)} = \sum_{x:\mu(x) > \nu(x)} \frac{(\mu(x) - \nu(x))^2}{\mu(x) - \nu(x)} \cdot \frac{\mu(x) - \nu(x)}{\mu(x) + \nu(x)} \stackrel{(**)}{\leq} \frac{\|\mu - \nu\|_1}{2}.$$

Here (**) follows from $\frac{\mu(x) - \nu(x)}{\mu(x) + \nu(x)} \leq 1$.

□

We will make use of the following:

Proposition B.1 ([Yeh20]). *If $|\eta| \leq \sqrt{a(b+\eta)}$ with $a, b \geq 0$, then $\eta \leq a + 2b$.*

Proof. If $a = 0$, then $\eta = 0$ and the upper-bound follows. Otherwise, if $\eta^2 - a\eta - ab \leq 0$, then

$$\eta \leq \frac{a + \sqrt{a^2 + 4ab}}{2} = \frac{a}{2}(1 + \sqrt{1 + 4b/a}) \leq \frac{a}{2}(1 + 1 + 4b/a). \quad \square$$

Proposition 3.9. *For any function $f : \Omega \rightarrow \mathbb{R}_{\geq 0}$,*

$$\mathbb{E}_{\mu}[f(x)] \leq \Lambda(\mu, \nu) \cdot \max_{x \in \Omega} f(x) + 6 \cdot \mathbb{E}_{\nu}[f(x)].$$

Proof. We have:

$$\begin{aligned} |\eta| &= \left| \mathbb{E}_{\mu}(f(x)) - \mathbb{E}_{\nu}(f(x)) \right| = \left| \sum_x (\mu(x) - \nu(x))f(x) \right| \\ &\leq \sum_x |(\mu(x) - \nu(x))| f(x) && \text{(By triangle inequality)} \\ &= \sum_x \frac{|\mu(x) - \nu(x)|\sqrt{f(x)}}{\sqrt{\mu(x) + \nu(x)}} \sqrt{(\mu(x) + \nu(x))f(x)} \\ &\leq \sqrt{\sum_x \frac{(\mu(x) - \nu(x))^2 f(x)}{\mu(x) + \nu(x)}} \sqrt{\sum_x (\mu(x) + \nu(x))f(x)} \\ &&& \text{(By Cauchy-Schwarz)} \end{aligned}$$

Let us look at the first term without the square root:

$$\begin{aligned} \sum_x \frac{(\mu(x) - \nu(x))^2 f(x)}{\mu(x) + \nu(x)} &= \sum_{x: \mu(x) \geq \nu(x)} \frac{(\mu(x) - \nu(x))^2 f(x)}{\mu(x) + \nu(x)} + \sum_{x: \mu(x) < \nu(x)} \frac{(\mu(x) - \nu(x))^2 f(x)}{\mu(x) + \nu(x)} \\ &\leq \Lambda(\mu, \nu) \cdot \max_x f(x) + \sum_{x: \mu(x) < \nu(x)} \frac{(\mu(x) - \nu(x))^2 f(x)}{\mu(x) + \nu(x)} \\ &\leq \Lambda(\mu, \nu) \cdot \max_x f(x) + \sum_x \frac{(\nu(x))^2}{\nu(x)} f(x) = \Lambda(\mu, \nu) \cdot \max_x f(x) + \mathbb{E}_{\nu}(f(x)). \end{aligned}$$

which implies:

$$|\eta| = \left| \mathbb{E}_{\mu}(f(x)) - \mathbb{E}_{\nu}(f(x)) \right| \leq \sqrt{\underbrace{(\Lambda(\mu, \nu) \cdot \max_x f(x) + \mathbb{E}_{\nu}(f(x)))}_{a} \underbrace{(\eta + 2\mathbb{E}_{\nu}(f(x)))}_{b}}$$

At this point, we can use Proposition B.1 to get the following:

$$\begin{aligned} \mathbb{E}_{\mu}(f(x)) - \mathbb{E}_{\nu}(f(x)) &\leq \Lambda(\mu, \nu) \cdot \max_x f(x) + 5 \mathbb{E}_{\nu}(f(x)), \\ \text{i.e., } \mathbb{E}_{\mu}(f(x)) &\leq \Lambda(\mu, \nu) \cdot \max_x f(x) + 6 \mathbb{E}_{\nu}(f(x)), \end{aligned}$$

which completes the proof. □

Proposition 3.10. *Positive triangular discrimination $\Lambda(\mu, \nu)$ is convex as a joint function of the two distributions μ and ν .*

Proof. To see this, it suffices to compute the Hessian of each term. We have

$$\Lambda(\mu, \nu) = \sum_x \begin{cases} \frac{(\mu(x) - \nu(x))^2}{\mu(x) + \nu(x)} & \text{if } \mu(x) \geq \nu(x) \\ 0 & \text{otherwise.} \end{cases}$$

So let us prove that each term is jointly convex in the values of $(\mu(x), \nu(x))$. We restrict our attention to the unit square. The function is zero, hence convex, inside the region where $\mu(x) \leq \nu(x)$. Furthermore, it is (obviously) non-negative inside the region where $\mu(x) > \nu(x)$. It is also convex in this region, since the Hessian is positive semidefinite there:

$$\nabla^2 \frac{(\mu(x) - \nu(x))^2}{\mu(x) + \nu(x)} = \begin{pmatrix} \frac{8\nu(x)^2}{(\mu(x) + \nu(x))^3} & -\frac{8\mu(x)\nu(x)}{(\mu(x) + \nu(x))^3} \\ -\frac{8\mu(x)\nu(x)}{(\mu(x) + \nu(x))^3} & \frac{8\mu(x)^2}{(\mu(x) + \nu(x))^3} \end{pmatrix}.$$

(The matrix is PSD since the off-diagonal entry, in absolute value, does not exceed the geometric mean of the diagonal entries.) It follows that each term is convex, and hence $\Lambda(\mu, \nu)$ is convex, in (μ, ν) . \square

C Proof of Claim 4.23

Proof. This proof is a verbatim reproduction of that in [ACK19]. For any $i \in [m]$, define $\mathbf{A}^{<i} := \{A_{x_1}, \dots, A_{x_{i-1}}\}$, $\mathbf{B}^{>i} := \{B_{x_{i+1}}, \dots, B_{x_m}\}$. Recall that the internal information cost of $\pi_{\text{Set-Int}}$ is $\text{IC}_{\mathcal{D}_{\text{Set-Int}}}(\pi_{\text{Set-Int}}) := \mathbb{I}(\mathbf{A}; \Pi_{\text{SI}} \mid \mathbf{B}) + \mathbb{I}(\mathbf{B}; \Pi_{\text{SI}} \mid \mathbf{A})$. In the following, we focus on bounding the first term. The second term can be bounded exactly the same by symmetry.

As $(\mathbf{l}, \mathbf{A}^{<i}, \mathbf{B}^{>i}, \mathbf{C}, \mathbf{D})$ is sampled via public randomness in $\pi_{\text{Set-Int}}$, by Proposition E.7,

$$\mathbb{I}(\mathbf{A}; \Pi_{\text{SI}} \mid \mathbf{B}) = \mathbb{I}(\mathbf{A}; \Pi_{\text{SI}} \mid \mathbf{B}, \mathbf{l}, \mathbf{A}^{<i}, \mathbf{B}^{>i}, \mathbf{C}, \mathbf{D}) \leq \mathbb{I}(\mathbf{A}; \Pi_{\text{SI}} \mid \mathbf{B}, \mathbf{l}, \mathbf{A}^{<i}, \mathbf{B}^{>i}).$$

The inequality is by Proposition E.4 as we now show $\mathbf{A} \perp (\mathbf{C}, \mathbf{D}) \mid \Pi_{\text{SI}}, \mathbf{B}, \mathbf{l}, \mathbf{A}^{<i}, \mathbf{B}^{>i}$ (and hence conditioning on (\mathbf{C}, \mathbf{D}) can only decrease the mutual information). This is because $\mathbf{A} \perp (\mathbf{C}, \mathbf{D}) \mid \mathbf{B}, \mathbf{l}, \mathbf{A}^{<i}, \mathbf{B}^{>i}$ by Observation 4.6 and Π_{SI} is transcript of a deterministic protocol plus z_1, \dots, z_j obtained deterministically and hence we can apply Proposition 4.7.

Define a random variable $\Theta \in \{0, 1\}$ where $\Theta = 1$ iff in Line (2) of protocol $\pi_{\text{Set-Int}}$, we terminate the protocol. In other words $\Theta = 1$ iff $x_i \in Z^{<j}$. Since $\mathbf{A} \perp \Theta \mid \mathbf{B}, \mathbf{l}, \mathbf{A}^{<i}, \mathbf{B}^{>i}$, further conditioning on Θ can only increase the mutual information term above by Proposition E.3, hence,

$$\begin{aligned} \mathbb{I}(\mathbf{A}; \Pi_{\text{SI}} \mid \mathbf{B}) &\leq \mathbb{I}(\mathbf{A}; \Pi_{\text{SI}} \mid \mathbf{B}, \mathbf{l}, \mathbf{A}^{<i}, \mathbf{B}^{>i}, \Theta) \\ &= \frac{m-j}{m} \cdot \mathbb{I}(\mathbf{A}; \Pi_{\text{SI}} \mid \mathbf{B}, \mathbf{l}, \mathbf{A}^{<i}, \mathbf{B}^{>i}, \Theta = 0) + \frac{j}{m} \cdot \mathbb{I}(\mathbf{A}; \Pi_{\text{SI}} \mid \mathbf{B}, \mathbf{l}, \mathbf{A}^{<i}, \mathbf{B}^{>i}, \Theta = 1) \\ &\leq \frac{m-j}{m} \cdot \mathbb{I}(\mathbf{A}; \Pi_{\text{SI}} \mid \mathbf{B}, \mathbf{l}, \mathbf{A}^{<i}, \mathbf{B}^{>i}, \Theta = 0), \end{aligned} \tag{1}$$

since conditioned on $\Theta = 1$, the protocol Π_{SI} is simple some prefix of $Z^{<j}$ and is hence independent of the input (\mathbf{A}, \mathbf{B}) and carries no information about \mathbf{A} (see Fact E.2-(2)). We now further bound the RHS of Eq (1). When $\Theta = 0$, $\Pi_{\text{SI}} = (Z^{<j}, \Pi_1, \dots, \Pi_j) = (E^{<j}, \Pi_j)$. Hence, we can write,

$$\begin{aligned} \mathbb{I}(\mathbf{A}; \Pi_{\text{SI}} \mid \mathbf{B}, \mathbf{l}, \mathbf{A}^{<i}, \mathbf{B}^{>i}, \Theta = 0) &\leq \mathbb{I}(\mathbf{A}; E_j, \Pi_j \mid \mathbf{B}, \mathbf{l}, \mathbf{A}^{<i}, \mathbf{B}^{>i}, \Theta = 0) \\ &= \mathbb{I}(\mathbf{A}; Z^{<j} \mid \mathbf{B}, \mathbf{l}, \mathbf{A}^{<i}, \mathbf{B}^{>i}, \Theta = 0) \\ &\quad + \mathbb{I}(\mathbf{A}; \Pi^{<j}, \Pi_j \mid Z^{<j}, \mathbf{B}, \mathbf{l}, \mathbf{A}^{<i}, \mathbf{B}^{>i}, \Theta = 0) \\ &\quad \text{(by chain rule in Fact E.2-(7) and since } E_j = (\Pi^{<j}, Z^{<j})) \\ &\leq \mathbb{I}(\mathbf{A}; \Pi \mid Z^{<j}, \mathbf{B}, \mathbf{l}, \mathbf{A}^{<i}, \mathbf{B}^{>i}, \Theta = 0), \end{aligned}$$

as $\mathbf{A} \perp \mathbf{Z}^{<j} \mid \Theta = 0$ (and other variables) and hence the first term is zero, and in the second term Π contains $\Pi^{<j}, \Pi_j$ (plus potentially other terms) and so having Π in instead can only increase the information. By further expanding the conditional information term above,

$$\begin{aligned}
& \mathbb{I}(\mathbf{A}; \Pi_{\mathbf{S}_1} \mid \mathbf{B}, \mathbf{l}, \mathbf{A}^{<l}, \mathbf{B}^{>l}, \Theta = 0) \\
& \leq \mathbb{E}_{(Z^{<j}, i) \mid \Theta = 0} [\mathbb{I}(\mathbf{A}; \Pi \mid \mathbf{B}, \mathbf{A}^{<i}, \mathbf{B}^{>i}, \mathbf{l} = i, \mathbf{Z}^{<j} = Z^{<j}, \Theta = 0)] \\
& = \mathbb{E}_{Z^{<j} \mid \Theta = 0} \left[\sum_{\substack{i=1 \\ i \notin Z^{<j}}}^m \frac{1}{m-j} \mathbb{I}(\mathbf{A}_{x_i}; \Pi \mid \mathbf{B}_{x_i}, \mathbf{A}^{<i}, \mathbf{B}^{>i}, \mathbf{l} = i, \mathbf{Z}^{<j} = Z^{<j}, \Theta = 0) \right] \\
& \quad (\text{conditioned on } \Theta = 0, i \text{ is chosen uniformly at random from } Z^{<j}; \text{ also } (\mathbf{A}, \mathbf{B}) = (\mathbf{A}_{x_i}, \mathbf{B}_{x_i})) \\
& = \mathbb{E}_{Z^{<j} \mid \Theta = 0} \left[\sum_{i \notin Z^{<j}} \frac{1}{m-j} \cdot \mathbb{I}(\mathbf{A}_{x_i}; \Pi \mid \mathbf{B}_{x_i}, \mathbf{A}^{<i}, \mathbf{B}^{>i}, \mathbf{Z}^{<j} = Z^{<j}, \Theta = 0) \right] \\
& \quad (\text{we dropped the conditioning on } \mathbf{l} = i \text{ as all remaining variables are independent of this event}) \\
& = \mathbb{E}_{Z^{<j} \mid \Theta = 0} \left[\sum_{i \notin Z^{<j}} \frac{1}{m-j} \cdot \mathbb{I}(\mathbf{A}_{x_i}; \Pi \mid \mathbf{A}^{<i}, \mathbf{B}, \mathbf{Z}^{<j} = Z^{<j}, \Theta = 0) \right] \\
& \quad (\text{as } \mathbf{A}_{x_i} \perp \mathbf{B}^{<i} \mid \mathbf{B}_{x_i}, \mathbf{A}^{<i} \text{ by Observation 4.6 and hence we can apply Proposition E.3}) \\
& \leq \mathbb{E}_{Z^{<j} \mid \Theta = 0} \left[\sum_{i=1}^m \frac{1}{m-j} \cdot \mathbb{I}(\mathbf{A}_{x_i}; \Pi \mid \mathbf{A}^{<i}, \mathbf{B}, \mathbf{Z}^{<j} = Z^{<j}, \Theta = 0) \right]
\end{aligned}$$

(mutual information is non-negative by Fact E.2-(2) and so we can add the terms in $Z^{<j}$ as well)

$$\begin{aligned}
& = \mathbb{E}_{Z^{<j} \mid \Theta = 0} \left[\sum_{i=1}^m \frac{1}{m-j} \cdot \mathbb{I}(\mathbf{A}_{x_i}; \Pi \mid \mathbf{A}^{<i}, \mathbf{B}, \mathbf{Z}^{<j} = Z^{<j}, \Theta = 0) \right] \\
& = \frac{1}{m-j} \cdot \mathbb{E}_{Z^{<j} \mid \Theta = 0} [\mathbb{I}(\mathbf{A}; \Pi \mid \mathbf{B}, \mathbf{Z}^{<j} = Z^{<j}, \Theta = 0)] \quad (\text{by chain rule in Fact E.2-(7)}) \\
& = \frac{1}{m-j} \cdot \mathbb{I}(\mathbf{A}; \Pi \mid \mathbf{B}, \mathbf{Z}^{<j}, \Theta = 0) \\
& \leq \frac{1}{m-j} \cdot (\mathbb{I}(\mathbf{A}; \Pi \mid \mathbf{B}, \Theta = 0) + \mathbb{H}(\mathbf{Z}^{<j})) \\
& = \frac{1}{m-j} \cdot (\mathbb{I}(\mathbf{A}; \Pi \mid \mathbf{B}) + \mathbb{H}(\mathbf{Z}^{<j})) \\
& \quad (\text{transcript of the protocol } \pi_{\text{BHPC}} \text{ (namely } \Pi) \text{ on input } (\mathbf{A}, \mathbf{B}) \text{ is independent of } \Theta) \\
& \leq \frac{1}{m-j} \cdot (\mathbb{H}(\Pi) + \mathbb{H}(\mathbf{Z}^{<j})) \leq \frac{\text{CC}(\pi_{\text{BHPC}})}{m-j} + \frac{j \cdot \log m}{m-j}. \\
& \quad (\text{by sub-additivity of entropy (Fact E.2-(5)) and Fact E.2-(1)})
\end{aligned}$$

By plugging in this bound in Eq (1), we have that,

$$\mathbb{I}(\mathbf{A}; \Pi_{\mathbf{S}_1} \mid \mathbf{B}) \leq \frac{m-j}{m} \cdot \left(\frac{\text{CC}(\pi_{\text{BHPC}})}{m-j} + \frac{j \cdot \log m}{m-j} \right) = \frac{\text{CC}(\pi_{\text{BHPC}})}{m} + \frac{j \cdot \log m}{m}.$$

By symmetry, we can also prove the same bound on $\mathbb{I}(\mathbf{B}; \Pi_{\mathbf{S}_1} \mid \mathbf{A})$. As such, we have,

$$\mathbb{I}(\mathbf{A}; \Pi_{\mathbf{S}_1} \mid \mathbf{B}) + \mathbb{I}(\mathbf{B}; \Pi_{\mathbf{S}_1} \mid \mathbf{A}) \leq 2 \cdot \left(\frac{\text{CC}(\pi_{\text{BHPC}})}{m} + \frac{j \cdot \log m}{m} \right).$$

We shall note that strictly speaking the factor 2 above is not needed (similar to the proof of Proposition E.8) but as this factor is anyway suppressed through O-notation later in the proof, the above bound suffices for our purpose. □

D Proof of Lemma 5.3

Consider the graph $G' = (V', E')$. Set $d = 6mr + 3m$. We add d auxiliary nodes in V_{aux} . Since the target degree of each node outside S is at most d , and the nodes in S need at most $6r + 3m \leq d$ edges to reach target degree, the d auxiliary nodes suffice to increase their degree. Thus, the total number of vertices in G is $|V'| + d = \Theta(mr)$.

We now describe the construction. For each node $v \in V'$, define its deficiency $\text{def}(v)$ as the difference between its target degree mentioned above and its current degree in G' . Define the total deficiency $D := \sum_{v \in V'} \text{def}(v)$. Fix arbitrary orderings $v_1, v_2, \dots, v_{|V'|}$ of the nodes in V' and u_1, \dots, u_d of the nodes in V_{aux} . From each v_i , we join edges to $\text{def}(v_i)$ many u_j 's following the ordering. The first neighbor of v_{i+1} is taken to be the node that is next to the last neighbor of v_i in the ordering of the u_j 's. We wrap around to u_1 after u_d . Hence, the degree of two vertices in V_{aux} can differ by at most 1. We check the min-degree of a node in V_{aux} . If it's $\geq d + 6r + 3$, then we are done. Otherwise, suppose it's $d + 6r + 3 - x$ for some $x > 0$. Then we add x disjoint matchings of size $d/2$ in V_{aux} to increase the degree of each node by x , i.e., to ensure that each node in V_{aux} has degree $\geq d + 6r + 3$.

It remains to prove the “furthermore” part. For this, we check the maximum and minimum deficiency of each node.

Observe that in G' , each node in layer 0 has degree at least 5 (it's adjacent to the other 2 nodes in its triple and to the 3 nodes in S) and at most $2m + 5$ (for each $i \in [m]$, it is adjacent to at most 2 nodes that represent i in layer 1). Hence, the deficiency of any such node is in $[d - 2m - 5, d - 5]$.

For any node in a layer $\ell \in [2r - 1]$, it is adjacent to at least 8 nodes (the other 2 nodes in its triple, the 3 nodes in S , and the 3 nodes representing the same element in its “paired layer”, i.e., layer $\ell + 1$ if ℓ is odd, or layer $\ell - 1$ if it's even) and at most $2m + 8$ nodes (for each $i \in [m]$, it is adjacent to at most 2 nodes that represent i in layer $\ell - 1$ if ℓ is odd, or layer $\ell + 1$ if it's even). Thus, the deficiency of any such node is in $[d - 2m - 8, d - 8]$.

Any node in layer $2r$ representing x_i with $b(x_i) = 0$ has degree exactly 5 (the 2 nodes in its triple and the 3 nodes representing the same element in layer $2r - 1$). Finally, any other nodes in layer $2r$ has degree exactly 8 (same as other nodes in layer $2r$ with the addition of the 3 nodes in S). Hence, the deficiency of any such node is in $[d - 8, d - 5]$.

Therefore, the total deficiency D is at least $(d - 2m - 8) \cdot |V_L| = (d - 2m - 8) \cdot d \geq 9d^2/10$ for large enough m . These edges are received almost equally by the d nodes in $|V_{\text{aux}}|$. Thus, the min-degree in $|V_{\text{aux}}|$ after the addition of these edges is at least $9d/10$. Thus the value of x is at most $d + 6r + 3 - 9d/10 \leq d - 3$ (again for large enough m). The x matchings can induce degree at most $x \leq d - 3$ in the subgraph $G[V_{\text{aux}}]$, and hence we are done with the furthermore part.

E Background on Information Theory

We now briefly introduce some definitions and facts from information theory that are needed in this thesis. We refer the interested reader to the text by Cover and Thomas [CT06] for an excellent introduction to this field, and the proofs of the statements used in this Appendix.

For a random variable A , we use $\text{SUPP}(A)$ to denote the support of A and $\text{dist}(A)$ to denote its distribution. When it is clear from the context, we may abuse the notation and use A directly

instead of $\text{dist}(A)$, for example, write $A \sim A$ to mean $A \sim \text{dist}(A)$, i.e., A is sampled from the distribution of random variable A .

We denote the *Shannon Entropy* of a random variable A by $\mathbb{H}(A)$, which is defined as:

$$\mathbb{H}(A) := \sum_{A \in \text{SUPP}(A)} \Pr(A = A) \cdot \log(1/\Pr(A = A)) \quad (2)$$

The *conditional entropy* of A conditioned on B is denoted by $\mathbb{H}(A | B)$ and defined as:

$$\mathbb{H}(A | B) := \mathbb{E}_{B \sim B} [\mathbb{H}(A | B = B)], \quad (3)$$

where $\mathbb{H}(A | B = B)$ is defined in a standard way by using the distribution of A conditioned on the event $B = B$ in Eq (2).

Recall that the binary entropy $H(p)$ is the entropy of a two-valued random variable that takes one value with probability p . We need the following upper bound on the binary entropy.

Fact E.1. *The binary entropy $H_2(p) \leq 2\sqrt{p \cdot (1-p)}$.*

The *mutual information* of two random variables A and B is denoted by $\mathbb{I}(A; B)$ and is defined as:

$$\mathbb{I}(A; B) := \mathbb{H}(A) - \mathbb{H}(A | B) = \mathbb{H}(B) - \mathbb{H}(B | A). \quad (4)$$

The *conditional mutual information* $\mathbb{I}(A; B | C)$ is $\mathbb{H}(A | C) - \mathbb{H}(A | B, C)$ and hence by linearity of expectation:

$$\mathbb{I}(A; B | C) = \mathbb{E}_{C \sim C} [\mathbb{I}(A; B | C = C)]. \quad (5)$$

E.1 Useful Properties of Entropy and Mutual Information

We shall use the following basic properties of entropy and mutual information throughout.

Fact E.2. *Let A, B, C , and D be four (possibly correlated) random variables.*

1. $0 \leq \mathbb{H}(A) \leq \log |\text{SUPP}(A)|$. *The right equality holds iff $\text{dist}(A)$ is uniform.*
2. $\mathbb{I}(A; B | C) \geq 0$. *The equality holds iff A and B are independent conditioned on C .*
3. $\mathbb{I}(A; B | C) \leq \mathbb{H}(A)$.
4. *Conditioning on a random variable reduces entropy: $\mathbb{H}(A | B, C) \leq \mathbb{H}(A | B)$. The equality holds iff $A \perp C | B$.*
5. *Subadditivity of entropy: $\mathbb{H}(A, B | C) \leq \mathbb{H}(A | C) + \mathbb{H}(B | C)$.*
6. *Chain rule for entropy: $\mathbb{H}(A, B | C) = \mathbb{H}(A | C) + \mathbb{H}(B | C, A)$.*
7. *Chain rule for mutual information: $\mathbb{I}(A, B; C | D) = \mathbb{I}(A; C | D) + \mathbb{I}(B; C | A, D)$.*
8. *Data processing inequality: for a function $f(A)$ of A , $\mathbb{I}(f(A); B | C) \leq \mathbb{I}(A; B | C)$.*

We also use the following two standard propositions, regarding the effect of conditioning on mutual information.

Proposition E.3. For random variables A, B, C, D , if $A \perp D \mid C$, then,

$$\mathbb{I}(A; B \mid C) \leq \mathbb{I}(A; B \mid C, D).$$

Proof. Since A and D are independent conditioned on C , by Fact E.2-(4), $\mathbb{H}(A \mid C) = \mathbb{H}(A \mid C, D)$ and $\mathbb{H}(A \mid C, B) \geq \mathbb{H}(A \mid C, B, D)$. We have,

$$\begin{aligned} \mathbb{I}(A; B \mid C) &= \mathbb{H}(A \mid C) - \mathbb{H}(A \mid C, B) = \mathbb{H}(A \mid C, D) - \mathbb{H}(A \mid C, B) \\ &\leq \mathbb{H}(A \mid C, D) - \mathbb{H}(A \mid C, B, D) = \mathbb{I}(A; B \mid C, D). \quad \square \end{aligned}$$

□

Proposition E.4. For random variables A, B, C, D , if $A \perp D \mid B, C$, then,

$$\mathbb{I}(A; B \mid C) \geq \mathbb{I}(A; B \mid C, D).$$

Proof. Since $A \perp D \mid B, C$, by Fact E.2-(4), $\mathbb{H}(A \mid B, C) = \mathbb{H}(A \mid B, C, D)$. Moreover, since conditioning can only reduce the entropy (again by Fact E.2-(4)),

$$\begin{aligned} \mathbb{I}(A; B \mid C) &= \mathbb{H}(A \mid C) - \mathbb{H}(A \mid B, C) \geq \mathbb{H}(A \mid D, C) - \mathbb{H}(A \mid B, C) \\ &= \mathbb{H}(A \mid D, C) - \mathbb{H}(A \mid B, C, D) = \mathbb{I}(A; B \mid C, D). \quad \square \end{aligned}$$

□

E.2 Background on Communication and Information Complexity

Communication complexity. We briefly review the standard definitions of the two-party communication model of Yao [Yao79]. See the text by Kushilevitz and Nisan [KN97] for an extensive overview of communication complexity. In Section 4, we also use a standard generalization of this model to allow for more than two players, but we defer the necessary definitions to that section.

Let $P : \mathcal{X} \times \mathcal{Y} \rightarrow \mathcal{Z}$ be a relation. Alice receives an input $X \in \mathcal{X}$ and Bob receives $Y \in \mathcal{Y}$, where (X, Y) are chosen from a joint distribution \mathcal{D} over $\mathcal{X} \times \mathcal{Y}$. We allow players to have access to both public and private randomness. They communicate with each other by exchanging messages such that each message depends only on the private input and random bits of the player sending the message, and the already communicated messages plus the public randomness. At the end, one of the players need to output an answer Z such that $Z \in P(X, Y)$.

We use π to denote a protocol used by the players. We always assume that the protocol π can be randomized (using both public and private randomness), *even against a prior distribution \mathcal{D} of inputs*. For any $0 < \delta < 1$, we say π is a δ -error protocol for P over a distribution \mathcal{D} , if the probability that for an input (X, Y) , π outputs some Z where $Z \notin P(X, Y)$ is at most δ (the probability is taken over the randomness of *both* the distribution and the protocol).

Definition E.5 (Communication cost). The *communication cost* of a protocol π on an input distribution \mathcal{D} , denoted by $CC_{\mathcal{D}}(\pi)$, is the *worst-case* bit-length of the transcript communicated between Alice and Bob in the protocol π , when the inputs are chosen from \mathcal{D} .

Communication complexity of a problem P is defined as the minimum communication cost of a protocol π that solves P on every distribution \mathcal{D} with probability at least $2/3$.

Information complexity. There are several possible definitions of information cost of a communication protocol that have been considered depending on the application (see, e.g., [CSWY01, BJKS02, BBCR10, BR11, BEO⁺13]). We use the notion of *internal information cost* [BBCR10] that measures the average amount of information each player learns about the input of the other player by observing the transcript of the protocol.

Definition E.6 (Information cost). Consider an input distribution \mathcal{D} and a protocol π . Let $(X, Y) \sim \mathcal{D}$ denote the random variables for the input of Alice and Bob and Π be the the random variable for the transcript of the protocol *concatenated* with the public randomness R used by π . The (*internal*) *information cost* of π with respect to \mathcal{D} is $\text{IC}_{\mathcal{D}}(\pi) := \mathbb{I}_{\mathcal{D}}(\Pi; X | Y) + \mathbb{I}_{\mathcal{D}}(\Pi; Y | X)$.

One can also define information complexity of a problem P similar to communication complexity with respect to the information cost. However, we avoid presenting this definition formally due to some subtle technical issues that need to be addressed which lead to multiple different but similar-in-spirit definitions. As such, we state our results directly in terms of information cost.

Note that any public coin protocol is a distribution over private coins protocols, run by first using public randomness to sample a random string $R = R$ and then running the corresponding private coin protocol π^R . We also use Π^R to denote the transcript of the protocol π^R . We have the following standard proposition.

Proposition E.7. *For any distribution \mathcal{D} and any protocol π with public randomness R ,*

$$\text{IC}_{\mathcal{D}}(\pi) = \mathbb{I}_{\mathcal{D}}(\Pi; X | Y, R) + \mathbb{I}_{\mathcal{D}}(\Pi; Y | X, R) = \mathbb{E}_{R \sim R} [\text{IC}_{\mathcal{D}}(\pi^R)].$$

Proof. By definition of internal information cost,

$$\begin{aligned} \text{IC}_{\mathcal{D}}(\pi) &= \mathbb{I}_{\mathcal{D}}(\Pi; X | Y) + \mathbb{I}_{\mathcal{D}}(\Pi; Y | X) = \mathbb{I}(\Pi, R; X | Y) + \mathbb{I}(\Pi, R; Y | X) \\ &\quad (\Pi \text{ denotes the transcript and the public randomness}) \\ &= \mathbb{I}(R; X | Y) + \mathbb{I}(\Pi; X | Y, R) + \mathbb{I}(R; Y | X) + \mathbb{I}(\Pi; Y | X, R) \\ &\quad (\text{chain rule of mutual information, Fact E.2-(7)}) \\ &= \mathbb{I}(\Pi; X | Y, R) + \mathbb{I}(\Pi; Y | X, R) \\ &\quad (\mathbb{I}(R; X | Y) = \mathbb{I}(R; Y | X) = 0 \text{ since } R \perp X, Y \text{ and Fact E.2-(2)}) \\ &= \mathbb{E}_{R \sim R} [\mathbb{I}(\Pi; X | Y, R = R) + \mathbb{I}(\Pi; Y | X, R = R)] = \mathbb{E}_{R \sim R} [\text{IC}_{\mathcal{D}}(\pi^R)], \end{aligned}$$

concluding the proof. \square

The following well-known proposition relates communication cost and information cost.

Proposition E.8 (cf. [BR11]). *For any distribution \mathcal{D} and any protocol π : $\text{IC}_{\mathcal{D}}(\pi) \leq \text{CC}_{\mathcal{D}}(\pi)$.*

Proof. Let us assume first that π only uses private randomness and thus Π only contain the transcript. For any $b \in [\text{CC}_{\mathcal{D}}(\pi)]$, we define Π_b to be the b -th bit of the transcript. We have,

$$\begin{aligned} \text{IC}_{\mathcal{D}}(\pi) &= \mathbb{I}(\Pi; X | Y) + \mathbb{I}(\Pi; Y | X) \\ &= \sum_{b=1}^{\text{CC}_{\mathcal{D}}(\pi)} \mathbb{I}(\Pi_b; X | \Pi^{<b}, Y) + \mathbb{I}(\Pi_b; Y | \Pi^{<b}, X) \\ &\quad (\text{by chain rule of mutual information in Fact E.2-(7)}) \\ &= \sum_{b=1}^{\text{CC}_{\mathcal{D}}(\pi)} \mathbb{E}_{\Pi^{<b}} \left[\mathbb{I}(\Pi_b; X | \Pi^{<b} = \Pi^{<b}, Y) + \mathbb{I}(\Pi_b; Y | \Pi^{<b} = \Pi^{<b}, X) \right]. \end{aligned}$$

Consider each term in the RHS above. By conditioning on $\Pi^{<b}$, the player that transmit Π_b would become fix. If this player is Alice, then $\mathbb{I}(\Pi_b; Y | \Pi^{<b} = \Pi^{<b}, X) = 0$, because Π_b is only a function of $(\Pi^{<b}, X)$ in this case; similarly, if this player is Bob, then $\mathbb{I}(\Pi_b; X | \Pi^{<b} = \Pi^{<b}, Y) = 0$. Moreover, $\mathbb{I}(\Pi_b; X | \Pi^{<b} = \Pi^{<b}, Y) \leq \mathbb{H}(\Pi_b) \leq 1$ and similarly $\mathbb{I}(\Pi_b; Y | \Pi^{<b} = \Pi^{<b}, X) \leq 1$. As such, the above term can be upper bounded by $\text{CC}_{\mathcal{D}}(\pi)$. To finalize the proof, note that by Proposition E.7, for any public-coin protocol π , $\text{IC}_{\mathcal{D}}(\pi) = \mathbb{E}_{R \sim R} [\text{IC}_{\mathcal{D}}(\pi^R)] \leq \mathbb{E}_{R \sim R} [\text{CC}_{\mathcal{D}}(\pi^R)] \leq \text{CC}_{\mathcal{D}}(\pi)$, where the first inequality is by the first part of the argument. \square

Proposition E.8 provides a convenient way of proving communication complexity lower bounds by lower bounding information cost of any protocol.

Rectangle Property of Communication Protocols

We conclude this section by mentioning some basic properties of communication protocols. For any protocol π and inputs $x \in \mathcal{X}$ and $y \in \mathcal{Y}$, we define $\Pi_{x,y}$ as the transcript of the protocol conditioned on the input x to Alice and input y to Bob. Note that for randomized protocols, $\Pi_{x,y}$ is a random variable which we denote by $\Pi_{x,y}$.

The following is referred to as the rectangle property of deterministic protocols.

Fact E.9 (Rectangle property). *For any deterministic protocol π and inputs $x, x' \in \mathcal{X}$ to Alice and $y, y' \in \mathcal{Y}$ to Bob, if $\Pi_{x,y} = \Pi_{x',y'}$, then $\Pi_{x,y'} = \Pi_{x',y}$.*

Fact E.9 implies that the set of inputs consistent with any transcript $\Pi_{x,y}$ of a deterministic protocol forms a combinatorial rectangle. One can also extend the rectangle property of deterministic protocols to randomized protocols using the following fact.

Fact E.10 (Cut-and-paste property; cf. [BJKS02]). *For any randomized protocol π and inputs $x, x' \in \mathcal{X}$ to Alice and $y, y' \in \mathcal{Y}$ to Bob, $h(\Pi_{x,y}, \Pi_{x',y'}) = h(\Pi_{x,y'}, \Pi_{x',y})$.*