

# NATURALISTIC MUSIC DECODING FROM EEG DATA VIA LATENT DIFFUSION MODELS

Emilian Postolache<sup>1,2</sup>, Natalia Polouliakh<sup>3</sup>, Hiroaki Kitano<sup>3</sup>,  
Akima Connelly<sup>3</sup>, Emanuele Rodolà<sup>1</sup>, Taketo Akama<sup>3</sup>

<sup>1</sup>Ca' Foscari University of Venice  
<sup>2</sup>Sapienza University of Rome  
<sup>3</sup>Sony CSL, Tokyo

## ABSTRACT

In this article, we explore the potential of using latent diffusion models, a family of powerful generative models, for the task of reconstructing naturalistic music from electroencephalogram (EEG) recordings. Unlike simpler music with limited timbres, such as MIDI-generated tunes or monophonic pieces, the focus here is on intricate music featuring a diverse array of instruments, voices, and effects, rich in harmonics and timbre. This study represents an initial foray into achieving general music reconstruction of high-quality using non-invasive EEG data, employing an end-to-end training approach directly on raw data without the need for manual pre-processing and channel selection. We train our models on the public NMED-T dataset and perform quantitative evaluation proposing neural embedding-based metrics. We additionally perform song classification based on the generated tracks. Our work contributes to the ongoing research in neural decoding and brain-computer interfaces, offering insights into the feasibility of using EEG data for complex auditory information reconstruction.

**Index Terms**— Music Generation, EEG Signal Processing, Diffusion Models

## 1. INTRODUCTION

In this paper, we focus on a method that decodes musical information from brain waves captured by electroencephalography (EEG). Reconstruction of musical information conditioned on functional magnetic resonance imaging (fMRI) has been recently proposed in [1] by mapping the signals to MuLan [2] embeddings and generating with the MusicLM [3] autoregressive model. Another work [4] performs realistic music reconstruction of unseen chunks of a song using electrocorticography (ECoG). The downside of fMRI and, especially, of ECoG, is the difficulty of acquiring data from subjects, since fMRI scanners are unfeasible for real-time capture while ECoG is invasive, placing electrodes inside the subject's skull. EEG instead is non-invasive, and can be recorded by wearable devices [5].

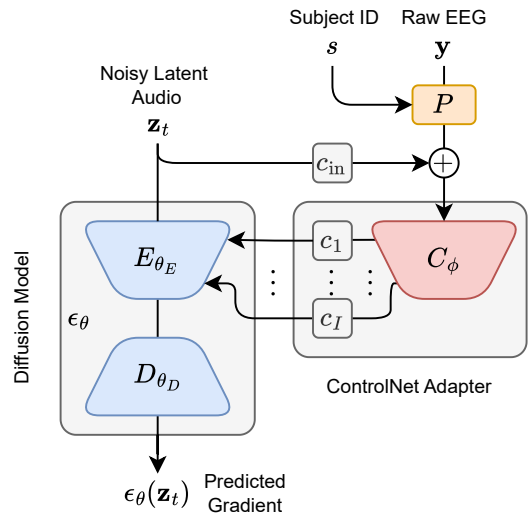

**Fig. 1. Illustration of proposed method.** We use ControlNet for conditioning a diffusion model on EEG data, in order to decode high-quality naturalistic music.

To our knowledge, [6] is the only work able to decode music from EEG signals alone (although with less success than when using a hybrid EEG-fMRI representation). At the same time, the method is limited by (i) the necessity for manually processing and filtering the raw data for successful training of the neural network decoder (a BLSTM [7]) and (ii) the focus on mono-timbral piano music which does not exhibit the variety of realistic music. In the vein of [8], which proposes a contrastive method for mapping speech to text without manually processing the dataset, we propose a method which is agnostic to manual pre-processing, based on denoising diffusion [9, 10]. We also target the more challenging scenario of naturalistic music decoding (i.e., complex music containing multiple stems, featuring rich timbre and harmony, as opposed to mono-timbral or MIDI generated music).

Diffusion models [9, 10] have proven to be a surprisingly powerful and flexible class of generative models, being applicable to any type of continuous data, such as images [11, 12],

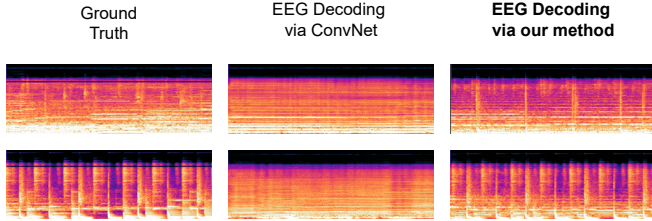

**Fig. 2. Qualitative results of our method.** On the left ground truth, musical chunks. In the middle, reconstructions obtained via a baseline ConvNet. On the right, decodings obtained by our method. Notice how our method better matches the real tracks.

videos [13], and audio [14, 15]. In the audio domain, in addition to general audio synthesis [16, 17], various models have been specialized in different tasks ranging from the synthesis of foley sound [18, 19], source separation [20, 21] and super-resolution [22]. Musical generation in a continuous domain (i.e., where the representation is not discrete like in MIDI or sheet music), both of a final track [23, 24] or at the sub-system level [25, 26, 27, 28], is particularly successful when approached with diffusion models, despite the intrinsic difficulty of capturing complex instrumental timbres and the coherence between different stems [29].

Recent works [30, 31] based on Stable Diffusion [12] have enabled the synthesis of high-quality images reconstructed from EEG recordings (for a more informative survey about the growing literature on multi-modal brainwave decoding, the reader can consult [32]). In this article we explore the use of ControlNet [33] as a mechanism for controlling AudioLDM2 [17], a large-scale pre-trained diffusion model on audio, using EEG data. While such a mechanism has been explored in the EEG to image literature with the CMVDM model [34], to our knowledge we are the first work that explores ControlNet for EEG to audio decoding (music in particular), performing such a task (i) without manual pre-processing/filtering and (ii) leveraging a naturalistic music dataset [35].

In Section 2 we review diffusion models and ControlNet. In Section 3 we describe how we apply such an architecture to our setting. Following, in Section 4 we describe the dataset and experimental setting and discuss the results in Section 5. We end the paper in Section 6.

## 2. BACKGROUND

### 2.1. Latent Diffusion Models

In the following we review latent diffusion models [12, 36], on which we base our methodology. Given a VAE [37] mapping an audio signal (e.g., waveform or mel-spectrogram)  $\mathbf{x}$  to a latent representation  $\mathbf{z}$  via a stochastic encoder  $E^{\text{VAE}}$ , i.e.,  $\mathbf{z} \sim E^{\text{VAE}}(\mathbf{x})$ , we can define a prior  $p_\theta$  via a dif-

fusion model  $\epsilon_\theta$ . Based on the DDPM formulation [10],  $\epsilon_\theta$  is trained to revert a forward Gaussian process, indexed by a time variable  $t$  ranging in  $[0, T]$ :

$$\mathbf{z}_t = \sqrt{\bar{\alpha}_t} \mathbf{z} + \sqrt{1 - \bar{\alpha}_t} \boldsymbol{\epsilon}, \quad \boldsymbol{\epsilon} \sim \mathcal{N}(\mathbf{0}, \mathbf{I}), \quad (1)$$

with  $\alpha_t = 1 - \beta_t$ ,  $\bar{\alpha}_t = \prod_{s=1}^t \alpha_s$ , and  $\{\beta_t\}_{t=1, \dots, T}$  a noise schedule. More specifically,  $\epsilon_\theta$  is parameterized by a neural network (typically a U-Net [38]), and estimates the noisy log gradient  $\nabla_{\mathbf{z}_t} \log p_\theta(\mathbf{z}_t)$  of the prior  $p_\theta$  via denoising score matching [9]:

$$\min_{\theta} \mathbb{E}_{\mathbf{z}, \boldsymbol{\epsilon}, t} [\|\boldsymbol{\epsilon} - \epsilon_\theta(\mathbf{z}_t, t)\|_2^2], \quad (2)$$

where we compute  $\mathbf{z}_t$  from latent data representations  $\mathbf{z}$  using Eq. 1.

At inference time, we first sample  $\hat{\mathbf{z}}_T \sim \mathcal{N}(\mathbf{0}, \mathbf{I})$  (i.e., the prior of the diffusion process following Eq. 1), and compute a backward sequence  $\{\hat{\mathbf{z}}_t\}$  integrating  $\epsilon_\theta$  via standard samplers such as DDIM [39] (which we employ in this paper). The  $\hat{\mathbf{z}}_t$  is finally decoded with the VAE decoder  $D^{\text{VAE}}$  resulting in the waveform output  $\hat{\mathbf{x}} = D^{\text{VAE}}(\hat{\mathbf{z}}_0)$ .

### 2.2. ControlNet

ControlNet [33] is a parameter-efficient fine-tuning method (PEFT) for (U-Net based) diffusion models, which lets us condition the base model on additional inputs  $\mathbf{y}$ . Given the U-Net architecture, we can write the diffusion model  $\epsilon_\theta$  as:

$$\epsilon_\theta(\mathbf{z}_t, t) = D_{\theta_D}(B_{\theta_B}(E_{\theta_E}(\mathbf{z}_t, t))),$$

with  $E_{\theta_E}$  an encoder,  $B_{\theta_B}$  an inner bottleneck and  $D_{\theta_D}$  a decoder mapping data back to the original dimensions. ControlNet defines an *adapter*  $C_\phi$ :

$$C_\phi(\mathbf{z}_t, \mathbf{y}, t) = E_\theta(c_{\text{in}}(P(\mathbf{y})) + \mathbf{z}_t, t), \quad (3)$$

initialized with the weights of a pre-trained  $E_{\theta_E}$ , where  $P$  is a projection matrix mapping  $\mathbf{y}$  to a tensor having the dimensions of  $\mathbf{z}_t$  and  $c_{\text{in}}$  a zero initialized convolution. While the original ControlNet adapter is additionally conditioned on text (following  $E_{\theta_E}$ ), we omit text-conditioning given that we do not use such a modality in this work. The ControlNet adapter outputs, for each layer  $i = 1, \dots, I$ , a feature  $C_\phi^i(\mathbf{z}_t, \mathbf{y}, t)$  which is first convolved with a zero-initialized convolution  $c_i$ , then summed to the features of the original U-Net encoder  $E_\theta^i(\mathbf{z}_t, t)$ , defining:

$$E_{\theta_E, \phi}^i(\mathbf{z}_t, \mathbf{y}, t) = c_i(C_\phi^i(\mathbf{z}_t, \mathbf{y}, t)) + E_\theta^i(\mathbf{z}_t, t). \quad (4)$$

The  $c_i$  convolutions improve the generalizability of the fine-tuned model and avoid catastrophic forgetting. The full ControlNet network  $\epsilon_{\theta, \phi}$  simply substitutes  $E_{\theta_E}$  with  $E_{\theta_E, \phi}$  and fine-tunes only the  $\phi$  weights, keeping the  $\theta$  weights frozen.

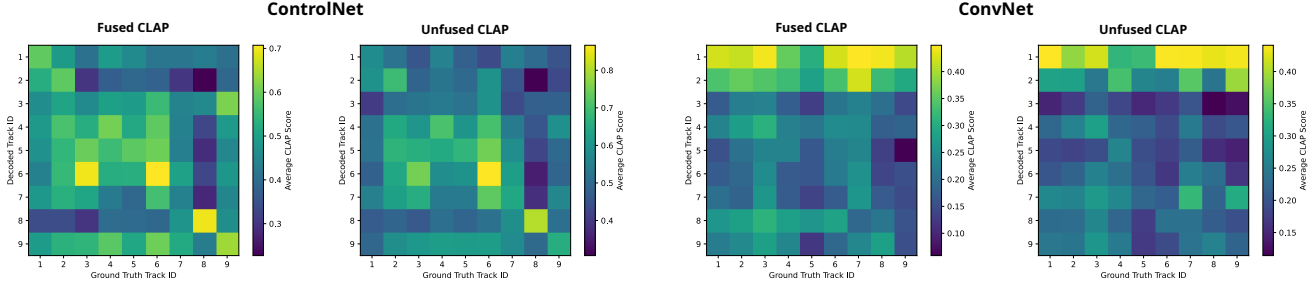

**Fig. 3. Classification of tracks based on CLAP Score.** Left: Our method. Right: Baseline convolutional network. Both methods are evaluated using Fused CLAP and Unfused CLAP. Notice how the confusion matrices are closer to diagonal with our method.

### 3. METHOD

#### 3.1. EEG-Conditioned ControlNet

In our method, we employ the ControlNet adapter to condition a (pre-trained) diffusion model on raw EEG information  $\mathbf{y} \in \mathbb{R}^{F_y \times S_y}$ , where  $F_y$  is the number of EEG channels and  $S_y$  the number of sampled time-steps. In this work,  $E^{\text{VAE}}$  is a 2D convolutional encoder mapping mel-spectrograms  $\mathbf{x} \in \mathbb{R}^{F_x \times S_x}$  ( $F_x$  is the number of frequencies and  $S_x$  the number of bins) to the latent representation  $\mathbf{z} \in \mathbb{R}^{F_z \times S_z \times D_z}$ , where  $F_z$  and  $S_z$  are the compressed window dimensions and  $D_z$  the latent channels. As shown in Eq. 3, we need to map  $\mathbf{y}$  with a projector  $P$  to a tensor having the dimensions of  $\mathbf{z}$  in order to combine the two sources of information in the ControlNet adapter input. We define the projector  $P: \mathbb{R}^{F_y \times S_y} \rightarrow \mathbb{R}^{F_z \times S_z \times D_z}$  as a strided 1D conv-net applied over the temporal dimension of  $\mathbf{y}$ , followed by a reshape operation.

We also experiment with adding a linear layer  $L(\mathbf{y}, s)$  dependent on a subject id  $s \in \mathbb{N}$ , as defined in [8]. In such a case, the final projector is obtained as the composition  $P \circ L$ . The subject layer modulates the input EEG based on the additional subject id information.

As mentioned in Section 1, we only apply minimal pre-processing to  $\mathbf{y}$ . Namely, we apply a robust scaler [8] followed by standard deviation clamping. Such methods are data-agnostic, and we do not rely on manual filtering.

#### 3.2. Neural Embedding-Based Metrics

Given the low resolution in the sampling of EEG data from current sensors (e.g., 1kHz) compared to that of audio (e.g., 41 kHz), it is difficult to faithfully reconstruct local track details. Yet, through generative methods such as the proposed model, we can reconstruct tracks at a semantic level, capturing details in a mid-global context (such as mood and timbral characteristics). To assess decoding quality in the aforementioned conditions we need to evaluate the outputs on a more compressed time scale, discarding local information. Therefore, in this paper, we propose to compute evaluation metrics

over embeddings  $\mathbf{e}$  and  $\hat{\mathbf{e}}$  obtained from ground truth tracks  $\mathbf{x}$  and generated outputs  $\hat{\mathbf{x}}$  (conditioned on EEG data  $\mathbf{y}$  corresponding to  $\mathbf{x}$ ) using CLAP [40, 41] (global scale) and EnCodec [42] (intermediate scale) encoders.

We propose to use the following metrics for measuring decoding quality:

- **FAD** — The Fréchet Audio Distance (FAD) [43] computes global perceptual quality over the distribution of the generations (i.e., without comparing individual samples). It is defined as the Wasserstein distance between Gaussians estimated on embedding sets of ground truth data  $\{\mathbf{e}_n\}$  and generated data  $\{\hat{\mathbf{e}}_n\}$ . We compute the embeddings both with CLAP and EnCodec. Other embedding spaces, such as VGGish [44], are not expressive enough for estimating robust metrics [45].

- **Pearson Coefficient** — Given a generated track  $\hat{\mathbf{x}}$  and a ground truth track  $\mathbf{x}$ , the (sample) Pearson correlation coefficient  $r$  is defined as:

$$r = \frac{\sum_i (\mathbf{e}_i - \boldsymbol{\mu})(\hat{\mathbf{e}}_i - \hat{\boldsymbol{\mu}})}{\sqrt{\sum_i (\mathbf{e}_i - \boldsymbol{\mu})^2} \sqrt{\sum_i (\hat{\mathbf{e}}_i - \hat{\boldsymbol{\mu}})^2}}, \quad (5)$$

with  $\boldsymbol{\mu}, \hat{\boldsymbol{\mu}}$  the means of  $\mathbf{e}, \hat{\mathbf{e}}$ , respectively. With CLAP embeddings, we notice that the means are very close to zero. Adding that such embeddings have unitary norm, Eq. 5 then becomes equivalent to the **CLAP Score**, the inner product  $\langle \mathbf{e}, \hat{\mathbf{e}} \rangle$ .

- **MSE** — With EnCodec embeddings, we also compute the mean square error  $\frac{1}{I} \|\mathbf{e} - \hat{\mathbf{e}}\|_2^2$  ( $I$  is the maximum time-step).

## 4. EXPERIMENTAL SETUP

#### 4.1. Dataset

We train our models on NMED-T (Naturalistic Music EEG Dataset - Tempo) [35]. The dataset contains the EEG recordings of 20 adult subjects listening, each, to 10 high-quality

**Table 1. Quantitative results.**

| Model (Architecture - Subject) | FAD ↓       |               | CLAP Score ↑ |             | Pearson Coefficient (EnCodec) ↑ |              | MSE (EnCodec) ↓ |             |
|--------------------------------|-------------|---------------|--------------|-------------|---------------------------------|--------------|-----------------|-------------|
|                                | CLAP        | EnCodec       | Test set     | OOD Track   | Test set                        | OOD Track    | Test set        | OOD Track   |
| Conv-2                         | 1.09        | 320.78        | 0.26         | -           | -0.0032                         | -            | 3.03            | -           |
| Pretrained                     | 0.80        | 163.31        | 0.38         | 0.38        | 0.010                           | 0.0047       | <b>1.93</b>     | 1.91        |
| ControlNet-2                   | 0.38        | 148.59        | <b>0.60</b>  | 0.58        | <b>0.018</b>                    | <b>0.010</b> | 1.96            | <b>1.72</b> |
| ControlNet-All                 | 0.42        | <b>147.06</b> | 0.59         | 0.39        | 0.010                           | 0.0074       | 1.99            | 1.82        |
| Scratch-2                      | 0.43        | 158.24        | 0.55         | <b>0.60</b> | 0.003                           | 0.0019       | 2.26            | 1.95        |
| Scratch-All                    | <b>0.36</b> | 174.65        | <b>0.60</b>  | 0.50        | 0.007                           | 0.0043       | 2.21            | 2.06        |

real songs (not synthesized from MIDI or monotonimbral). The EEG data is recorded with the Electrical Geodesics, Inc. (EGI) GES300 system [46] using 128 channels, and it is sampled at 1 kHz.

For our experiments, we keep the first track (Trigger 21) as a held-out, out-of-distribution test track. The other 9 songs are divided into train (0-80%), validation (80-90%), and test (90-100%) subchunks. The models are validated with the CLAP score during training. Such a choice stems from the difficulty of doing early stopping with the score matching metric in Eq. 2 during validation. Our minimal pre-processing pipeline involves excluding the face channels (retaining 124 channels), which we center using the mean over the first 1000 time steps, and we set 20 standard deviations for clamping.

## 4.2. Implementation Details

We implement the proposed ControlNet on top of the AudioLDM2 diffusion repository. Specifically, we use the `audioldm2-music` checkpoint, publicly available on HuggingFace<sup>1</sup>. For the ControlNet projection, we use (256, 512, 1024, 2048) channels with strides (5, 2, 2, 2). All models are trained with Adam [47] optimizer using a learning rate of  $10^{-4}$ . During training and inference, we ignore the textual conditioning mechanism of AudioLDM2 using as an input the constant string “Pop music”.

## 5. EXPERIMENTS

For our experiments, we train two types of models. First, we train the ControlNet with the frozen diffusion model, both only using data of subject 2 (ControlNet-2) and using all subject’s data (ControlNet-All). At the same time, we want to test how the model performs when training both the ControlNet adapter and the diffusion U-Net from scratch, leading to the Scratch-2 and Scratch-All models. We compare the models both with Conv-2, a simple convolutional network trained on subject 2 data (following the structure of the projector  $P$ ), and the “Pretrained” diffusion model, generating audio un-

conditionally (i.e., no EEG conditioning is occurring). When evaluating “All” models, we always use subject 2 test data.

We showcase qualitative examples in Figure 2, and on our site<sup>2</sup>, and list quantitative results in Table 1. The OOD Track represents the held-out track (see Section 4).

As we can see, in all metrics, the proposed method outperforms the regressor convolutional baseline (which was trained also on the OOD track). From the Table, we can gather additional information. We observe that the MSE (EnCodec) metric is not optimal for evaluation: the pre-trained model, which does not have access to EEG data, apparently beats our models trained specifically for the task. The situation improves with the Pearson Coefficient (EnCodec) metric. Here, the ControlNet-2 model achieves the best performance, yet Pretrained seems to be on par with the ControlNet-All version, still suggesting difficulties in evaluating the models.

Moving to global metrics such as the CLAP Score and the FAD, we see a higher improvement with respect to the Conv-2 and Pretrained baselines, reaching a 0.60 CLAP Score on ControlNet-2 and Scratch-All. On FAD, as well, our models show improved performance. Nonetheless, these metrics still cannot capture entirely the behaviour of the model given that it assigns a very high CLAP Score on the OOD Track with Scratch-2. Given the scarcity of data (we train only using 9 songs), we can only reconstruct unknown segments of known tracks. Aggregating the different metrics, we can agree that ControlNet-2 seems to perform best.

In Figure 3, we report the confusion matrices related to a classification experiment similar to the one in [6], both using the fused and unfused versions of the CLAP embedder. As the reader can observe, our model resembles more closely a diagonal matrix with respect to Conv-2.

## 6. CONCLUSIONS

In this paper, we have investigated the use of ControlNet for the task of naturalistic music decoding from EEG brainwaves. While we obtain non-negligible decoding results on unknown segments of known tracks, further research is required to improve generalization to distribution shift, both in terms of larger datasets and improved algorithms.

<sup>1</sup><https://huggingface.co/docs/diffusers/api/pipelines/audioldm2>

<sup>2</sup>[emilianpostolache.com/brainwave](http://emilianpostolache.com/brainwave)

## 7. ACKNOWLEDGMENTS

The authors were partially supported by the ERC grant no. 802554 (SPECGEO), PRIN 2020 project no. 2020TA3K9N (LEGO.AI), PRIN 2022 project no. 2022AL45R2 (EYE-FLAI, CUP H53D2300350-0001), and PNRR MUR project no. PE0000013-FAIR.

## 8. REFERENCES

- [1] Timo I Denk, Yu Takagi, Takuya Matsuyama, Andrea Agostinelli, Tomoya Nakai, Christian Frank, and Shinji Nishimoto, “Brain2music: Reconstructing music from human brain activity,” *arXiv preprint arXiv:2307.11078*, 2023.
- [2] Qingqing Huang, Aren Jansen, Joonseok Lee, Ravi Ganti, Judith Yue Li, and Daniel PW Ellis, “Mulan: A joint embedding of music audio and natural language,” in *Ismir 2022 Hybrid Conference*, 2022.
- [3] Andrea Agostinelli, Timo I Denk, Zalán Borsos, Jesse Engel, Mauro Verzetti, Antoine Caillon, Qingqing Huang, Aren Jansen, Adam Roberts, Marco Tagliasacchi, et al., “Musiclm: Generating music from text,” *arXiv preprint arXiv:2301.11325*, 2023.
- [4] Ludovic Bellier, Anaïs Llorens, Déborah Marciano, Aysegul Gunduz, Gerwin Schalk, Peter Brunner, and Robert T. Knight, “Music can be reconstructed from human auditory cortex activity using nonlinear decoding models,” *PLOS Biology*, vol. 21, no. 8, pp. 1–27, 08 2023.
- [5] Apple Inc, “Biosignal sensing device using dynamic selection of electrodes,” 2023, US Patent US20230225659A1.
- [6] Ian Daly, “Neural decoding of music from the eeg,” *Scientific Reports*, vol. 13, no. 1, pp. 624, 2023.
- [7] Sepp Hochreiter and Jürgen Schmidhuber, “Long short-term memory,” *Neural Comput.*, vol. 9, no. 8, pp. 1735–1780, nov 1997.
- [8] Alexandre Défossez, Charlotte Caucheteux, Jérémy Rapin, Ori Kabeli, and Jean-Rémi King, “Decoding speech perception from non-invasive brain recordings,” *Nature Machine Intelligence*, vol. 5, no. 10, pp. 1097–1107, 2023.
- [9] Yang Song and Stefano Ermon, “Generative modeling by estimating gradients of the data distribution,” *Advances in neural information processing systems*, vol. 32, 2019.
- [10] Jonathan Ho, Ajay Jain, and Pieter Abbeel, “Denoising diffusion probabilistic models,” *Advances in neural information processing systems*, vol. 33, pp. 6840–6851, 2020.
- [11] Prafulla Dhariwal and Alexander Nichol, “Diffusion models beat gans on image synthesis,” *Advances in neural information processing systems*, vol. 34, pp. 8780–8794, 2021.
- [12] Robin Rombach, Andreas Blattmann, Dominik Lorenz, Patrick Esser, and Björn Ommer, “High-resolution image synthesis with latent diffusion models,” in *Proceedings of the IEEE/CVF conference on computer vision and pattern recognition*, 2022, pp. 10684–10695.
- [13] Tim Brooks, Bill Peebles, Connor Holmes, Will DePue, Yufei Guo, Li Jing, David Schnurr, Joe Taylor, Troy Luhman, Eric Luhman, Clarence Ng, Ricky Wang, and Aditya Ramesh, “Video generation models as world simulators,” 2024.
- [14] Zhifeng Kong, Wei Ping, Jiaji Huang, Kexin Zhao, and Bryan Catanzaro, “Diffwave: A versatile diffusion model for audio synthesis,” in *International Conference on Learning Representations*, 2020.
- [15] Nanxin Chen, Yu Zhang, Heiga Zen, Ron J Weiss, Mohammad Norouzi, and William Chan, “Wavegrad: Estimating gradients for waveform generation,” in *International Conference on Learning Representations*, 2021.
- [16] Santiago Pascual, Gautam Bhattacharya, Chungshin Yeh, Jordi Pons, and Joan Serrà, “Full-band general audio synthesis with score-based diffusion,” in *ICASSP 2023-2023 IEEE International Conference on Acoustics, Speech and Signal Processing (ICASSP)*. IEEE, 2023, pp. 1–5.
- [17] Haohe Liu, Qiao Tian, Yi Yuan, Xubo Liu, Xinhao Mei, Qiuqiang Kong, Yuping Wang, Wenwu Wang, Yuxuan Wang, and Mark D Plumbley, “Audioldm 2: Learning holistic audio generation with self-supervised pretraining,” *arXiv preprint arXiv:2308.05734*, 2023.
- [18] Marco Comunità, Riccardo F Gramaccioni, Emilian Postolache, Emanuele Rodolà, Danilo Comminiello, and Joshua D Reiss, “SynCFusion: Multimodal onset-synchronized video-to-audio foley synthesis,” in *ICASSP 2024-2024 IEEE International Conference on Acoustics, Speech and Signal Processing (ICASSP)*. IEEE, 2024, pp. 936–940.
- [19] Yoonjin Chung, Junwon Lee, and Juhan Nam, “T-foley: A controllable waveform-domain diffusion model for temporal-event-guided foley sound synthesis,” *arXiv preprint arXiv:2401.09294*, 2024.

- [20] Robin Scheibler, Youna Ji, Soo-Whan Chung, Jaekuk Byun, Soyeon Choe, and Min-Seok Choi, “Diffusion-based generative speech source separation,” in *ICASSP 2023-2023 IEEE International Conference on Acoustics, Speech and Signal Processing (ICASSP)*. IEEE, 2023, pp. 1–5.
- [21] Shahar Lutati, Eliya Nachmani, and Lior Wolf, “Separate and diffuse: Using a pretrained diffusion model for better source separation,” in *The Twelfth International Conference on Learning Representations*, 2024.
- [22] Chin-Yun Yu, Sung-Lin Yeh, György Fazekas, and Hao Tang, “Conditioning and sampling in variational diffusion models for speech super-resolution,” in *ICASSP 2023-2023 IEEE International Conference on Acoustics, Speech and Signal Processing (ICASSP)*. IEEE, 2023, pp. 1–5.
- [23] Flavio Schneider, Zhijing Jin, and Bernhard Schölkopf, “Moûsai: Text-to-music generation with long-context latent diffusion,” *arXiv preprint arXiv:2301.11757*, 2023.
- [24] Zach Evans, CJ Carr, Josiah Taylor, Scott H Hawley, and Jordi Pons, “Fast timing-conditioned latent audio diffusion,” *arXiv preprint arXiv:2402.04825*, 2024.
- [25] Giorgio Mariani, Irene Tallini, Emilian Postolache, Michele Mancusi, Luca Cosmo, and Emanuele Rodolà, “Multi-source diffusion models for simultaneous music generation and separation,” in *The Twelfth International Conference on Learning Representations*, 2023.
- [26] Bing Han, Junyu Dai, Xuchen Song, Weituo Hao, Xinyan He, Dong Guo, Jitong Chen, Yuxuan Wang, and Yanmin Qian, “Instructme: An instruction guided music edit and remix framework with latent diffusion models,” *arXiv preprint arXiv:2308.14360*, 2023.
- [27] Emilian Postolache, Giorgio Mariani, Luca Cosmo, Emmanouil Benetos, and Emanuele Rodolà, “Generalized multi-source inference for text conditioned music diffusion models,” in *ICASSP 2024-2024 IEEE International Conference on Acoustics, Speech and Signal Processing (ICASSP)*. IEEE, 2024, pp. 6980–6984.
- [28] Julian D Parker, Janne Spijkervet, Katerina Kosta, Furkan Yesiler, Boris Kuznetsov, Ju-Chiang Wang, Matt Avent, Jitong Chen, and Duc Le, “Stemgen: A music generation model that listens,” in *ICASSP 2024-2024 IEEE International Conference on Acoustics, Speech and Signal Processing (ICASSP)*. IEEE, 2024, pp. 1116–1120.
- [29] Ruben Ciranni, Emilian Postolache, Giorgio Mariani, Michele Mancusi, Luca Cosmo, and Emanuele Rodolà, “Cocola: Coherence-oriented contrastive learning of musical audio representations,” 2024.
- [30] Yunpeng Bai, Xintao Wang, Yanpei Cao, Yixiao Ge, Chun Yuan, and Ying Shan, “Dreamdiffusion: Generating high-quality images from brain eeg signals,” *arXiv preprint arXiv:2306.16934*, 2023.
- [31] Yu-Ting Lan, Kan Ren, Yansen Wang, Wei-Long Zheng, Dongsheng Li, Bao-Liang Lu, and Lili Qiu, “Seeing through the brain: Image reconstruction of visual perception from human brain signals,” 2023.
- [32] Weijian Mai, Jian Zhang, Pengfei Fang, and Zhijun Zhang, “Brain-conditional multimodal synthesis: A survey and taxonomy,” *arXiv preprint arXiv:2401.00430*, 2023.
- [33] Lvmin Zhang, Anyi Rao, and Maneesh Agrawala, “Adding conditional control to text-to-image diffusion models,” in *Proceedings of the IEEE/CVF International Conference on Computer Vision*, 2023, pp. 3836–3847.
- [34] Bohan Zeng, Shanglin Li, Xuhui Liu, Sicheng Gao, Xiaolong Jiang, Xu Tang, Yao Hu, Jianzhuang Liu, and Baochang Zhang, “Controllable mind visual diffusion model,” in *Proceedings of the AAAI Conference on Artificial Intelligence*, 2024, vol. 38, pp. 6935–6943.
- [35] Steven Losorelli, Duc T. Nguyen, Jacek P. Dmochowski, and Blair Kaneshiro, “Nmed-t: A tempo-focused dataset of cortical and behavioral responses to naturalistic music,” in *International Society for Music Information Retrieval Conference*, 2017.
- [36] Arash Vahdat, Karsten Kreis, and Jan Kautz, “Score-based generative modeling in latent space,” *Advances in neural information processing systems*, vol. 34, pp. 11287–11302, 2021.
- [37] Diederik P. Kingma and Max Welling, “Auto-encoding variational bayes,” in *2nd International Conference on Learning Representations, ICLR 2014, Banff, AB, Canada, April 14-16, 2014, Conference Track Proceedings*, Yoshua Bengio and Yann LeCun, Eds., 2014.
- [38] Olaf Ronneberger, Philipp Fischer, and Thomas Brox, “U-net: Convolutional networks for biomedical image segmentation,” in *Medical Image Computing and Computer-Assisted Intervention—MICCAI 2015: 18th International Conference, Munich, Germany, October 5-9, 2015, Proceedings, Part III 18*. Springer, 2015, pp. 234–241.
- [39] Jiaming Song, Chenlin Meng, and Stefano Ermon, “Denosing diffusion implicit models,” in *International Conference on Learning Representations*, 2020.

- [40] Benjamin Elizalde, Soham Deshmukh, Mahmoud Al Ismail, and Huaming Wang, “Clap learning audio concepts from natural language supervision,” in *ICASSP 2023-2023 IEEE International Conference on Acoustics, Speech and Signal Processing (ICASSP)*. IEEE, 2023, pp. 1–5.
- [41] Yusong Wu, Ke Chen, Tianyu Zhang, Yuchen Hui, Taylor Berg-Kirkpatrick, and Shlomo Dubnov, “Large-scale contrastive language-audio pretraining with feature fusion and keyword-to-caption augmentation,” in *ICASSP 2023-2023 IEEE International Conference on Acoustics, Speech and Signal Processing (ICASSP)*. IEEE, 2023, pp. 1–5.
- [42] Alexandre Défossez, Jade Copet, Gabriel Synnaeve, and Yossi Adi, “High fidelity neural audio compression,” *Transactions on Machine Learning Research*, 2023.
- [43] Dominik Roblek, Kevin Kilgour, Matt Sharifi, and Mauricio Zuluaga, “Fr\`echet audio distance: A reference-free metric for evaluating music enhancement algorithms,” in *Proc. Interspeech*, 2019, pp. 2350–2354.
- [44] Shawn Hershey, Sourish Chaudhuri, Daniel PW Ellis, Jort F Gemmeke, Aren Jansen, R Channing Moore, Manoj Plakal, Devin Platt, Rif A Saurous, Bryan Seybold, et al., “Cnn architectures for large-scale audio classification,” in *2017 IEEE International Conference on Acoustics, Speech and Signal Processing (ICASSP)*. IEEE, 2017, pp. 131–135.
- [45] Azalea Gui, Hannes Gamper, Sebastian Braun, and Dimitra Emmanouilidou, “Adapting frechet audio distance for generative music evaluation,” in *ICASSP 2024-2024 IEEE International Conference on Acoustics, Speech and Signal Processing (ICASSP)*. IEEE, 2024, pp. 1331–1335.
- [46] Don M. Tucker, “Spatial sampling of head electrical fields: the geodesic sensor net,” *Electroencephalography and Clinical Neurophysiology*, vol. 87, no. 3, pp. 154–163, 1993.
- [47] Diederik P Kingma and Jimmy Ba, “Adam: A method for stochastic optimization,” *arXiv preprint arXiv:1412.6980*, 2014.