

Gröbner Basis Cryptanalysis of Ciminion and Hydra

Matthias Johann Steiner 

Alpen-Adria-Universität Klagenfurt, Klagenfurt am Wörthersee, Austria

matthias.steiner@aau.at

Abstract. *Ciminion* and *Hydra* are two recently introduced symmetric key Pseudo-Random Functions for Multi-Party Computation applications. For efficiency both primitives utilize quadratic permutations at round level. Therefore, polynomial system solving-based attacks pose a serious threat to these primitives. For *Ciminion* we construct a quadratic degree reverse lexicographic (DRL) Gröbner basis for the iterated polynomial model via affine transformations. For *Hydra* we provide a computer-aided proof in *SageMath* that a quadratic DRL Gröbner basis is already contained within the iterated polynomial system for the *Hydra* heads after affine transformations and a linear change of coordinates.

Our *Ciminion* DRL Gröbner basis simplifies cryptanalysis, since one does not need to impose genericity assumptions, like being regular or semi-regular, anymore to derive complexity estimates on key recovery attacks.

In the *Hydra* proposal it was claimed that $r_{\mathcal{H}} = 31$ rounds for the heads are sufficient to achieve 128 bits of security against Gröbner basis attacks for key recovery. However, for $r_{\mathcal{H}} = 31$ standard term order conversion to a lexicographic (LEX) Gröbner basis for our *Hydra* DRL Gröbner basis requires just 126 bits. Moreover, via the Eigenvalue Method up to $r_{\mathcal{H}} = 33$ rounds can be attacked below 128 bits.

Keywords: Gröbner basis · Eigenvalue Method · Ciminion · Hydra

1 Introduction

With secure *Multi-Party Computation* (MPC) several parties can jointly compute a function without revealing their private inputs. In practice, data often has to be securely transferred from and to third parties before it can be used in MPC protocols. Also, one may need to store intermediate results securely in a database. For efficiency, it is recommended to perform encryption via MPC-friendly *Pseudo-Random Functions* (PRF) [GRR⁺16] which utilize a secret-shared symmetric key. Moreover, one can utilize MPC-friendly PRFs to speed up MPC applications, e.g. [IKOS07, LTW13, CDG⁺17]. Compared to classical bit-based PRFs their MPC counterparts have two novel design criteria:

- They must be native over large finite fields \mathbb{F}_q , typically $\log_2(q) \geq 64$ and q is prime.
- They must admit a low number of multiplications for evaluation.

Two such recently introduced PRFs are *Ciminion* [DGGK21] and *Hydra* [GØSW23]. These constructions are based on the iteration of degree 2 Feistel and Lai–Massey permutations. Due to the low degree at round level, both designs consider Gröbner basis attacks [ACG⁺19] as one of the most threatening attack vectors.

Let us shortly review a Gröbner basis attack on an iterated design.

- (1) Model the function with an iterated system of polynomials

$$\mathcal{R}(\mathbf{x}_{i-1}, \mathbf{y}) - \mathbf{x}_i = \mathbf{0},$$

where $\mathcal{R} : \mathbb{F}_q^n \rightarrow \mathbb{F}_q^n$ is a round function. The \mathbf{x}_i 's are intermediate state variables with \mathbf{x}_0 the input state and \mathbf{x}_r the output state of the function and \mathbf{y} the cryptographic secret variables.

- (2) Compute a Gröbner basis with respect to an efficient term order, e.g. the degree reverse lexicographic (DRL) term order.
- (3) Convert to an elimination order, e.g. the lexicographic (LEX) term order.
- (4) Solve the univariate equation.

Let $I \subset P = \mathbb{F}_q[x_1, \dots, x_n]$ be a zero-dimensional ideal, let $d = \dim_{\mathbb{F}_q}(P/I)$ denote the \mathbb{F}_q -vector space dimension of the quotient space, and assume that a DRL Gröbner basis for I is known. The original FGLM algorithm [FGLM93] for term order conversion runs in $\mathcal{O}(n \cdot d^3)$. An improved probabilistic FGLM variant [FGHR14] runs in $\tilde{\mathcal{O}}(d^\omega)$, where $2 \leq \omega < 2.37286$, if the ideal is in shape position, and in $\tilde{\mathcal{O}}(n \cdot d^\omega)$ if a LEX Gröbner basis of the radical ideal is computed. Further, a sparse linear algebra FGLM variant [FM17] achieves $\mathcal{O}\left(\frac{d^{2+\frac{n-1}{n}}}{\sqrt{n}}\right)$. To factor the univariate LEX polynomial efficiently Bariant et al. [BBLP22, §3.1] proposed to compute its GCD with the field equation. To improve from the generic GCD complexity they propose to perform an auxiliary division by remainder to reduce both polynomials to the same degree. Provided that just a few solutions stem from the base field \mathbb{F}_q , the complexity of \mathbb{F}_q -valued root extraction via the GCD is given by

$$\mathcal{O}\left(d \cdot \log(d) \cdot \log(\log(d)) \cdot (\log(d) + \log(q))\right), \quad (1)$$

if $d \leq q$ else one has to replace the roles of d and q in the complexity estimate.

To estimate the complexity of Gröbner basis computations the Ciminion designers assumed that their polynomial systems are *regular* [Eis95, Chapter 17] and the Hydra designers assumed that their polynomial systems are *semi-regular* [Frö85, Par10]. Under these assumptions it is well-known that the complexity of Gröbner basis computations can be estimated via the *degree of regularity* [BFS04], but both designs lack a formal proof for their genericity assumptions.

Recently, Caminata & Gorla [CG21] introduced the notion of *being in generic coordinates*. Essentially, if a polynomial system is in generic coordinates, then the complexity of DRL Gröbner basis computations can always be expressed in terms of the *Macaulay bound*. We also note that for a regular polynomial system the degree of regularity is equal to the Macaulay bound.

In another recent work, Steiner [Ste24] analyzed several cryptographic polynomial systems of MiMC [AGR⁺16], HADES [GLR⁺20] and GMiMC [AGP⁺19] for being in generic coordinates. In particular, he derived an efficient criterion [Ste24, Theorem 3.2] to prove that a polynomial system is in generic coordinates. Moreover, in his analysis of GMiMC he revealed that iterated polynomial systems for Feistel polynomial systems can be verified to be in generic coordinates by computing the rank of an associated linear system. Our work can be seen as generalization of his work since Ciminion and Hydra essentially boil down to Feistel-like polynomial systems.

1.1 Our Results

For the iterated Ciminion polynomial system we prove in Theorem 3.1 that a DRL Gröbner basis can be constructed via affine transformations. This trivializes Step (2) in a Gröbner

basis attack, and one can directly proceed with term order conversion or other polynomial system solving techniques to solve for the key.

It is also worthwhile mentioning that Bariant [Bar23] recently described that the univariate LEX polynomial of `Ciminion` can be constructed via univariate polynomial multiplication. We review this construction in more detail in Section 3.2, most importantly his attack can be prevented with additional key additions in the rounds of `Ciminion`. Moreover, if the keys are only added to the non-linear components, then we can maintain the iterated DRL `Ciminion` Gröbner basis (Theorem 3.1). We call this slightly modified variant `Ciminion2` (Section 3.3.1).

For `Hydra`, in Theorem 4.1 we derive a linear system to verify generic coordinates for the iterated `Hydra` polynomial system. In case the `Hydra` polynomial system is in generic coordinates, then we can also use the linear system to perform a change of coordinates and produce a quadratic polynomial system which contains a zero-dimensional DRL Gröbner basis. For `Hydra` this gives us two options to solve for the key.

- (I) We ignore the additional equations and just use the DRL Gröbner basis to proceed with polynomial system solving.
- (II) We exploit the quadratic DRL Gröbner basis to reduce the standard Macaulay matrix for the overdetermined `Hydra` polynomial system to a submatrix whose columns are only indexed by square-free monomials.

For (I), to compute the solutions of our polynomial systems we take a different approach than the classical term order conversion to LEX. We propose to compute the zeros via the eigenvalues of the so-called *multiplication matrices*, see Section 2.5. Then, the complexity of the *Eigenvalue Method* is dominated by the complexity of determinant computations. We also note that the probabilistic FGLM algorithm [FM17] boils down to matrix multiplications with the multiplication matrices, hence the generic Eigenvalue Method and the probabilistic FGLM algorithm share the same complexity estimate up to multiplicative constants. In particular, in Section 5 we discuss how the multiplicative structure of quadratic DRL Gröbner bases can be exploited to improve the complexity of the determinant for the characteristic polynomial. Consequently, this will yield the best currently known attacks on `Hydra`.

For (II), computing a DRL Gröbner basis for multivariate quadratic polynomial systems is an omnipresent problem in cryptography. However, for the full `Hydra` polynomial system we have an advantage over the general problem, because the system already contains a zero-dimensional DRL Gröbner basis. Therefore, to decrease the size of the Macaulay matrices in a Gröbner basis computation, we propose to perform an auxiliary division by remainder computation with respect to the Gröbner basis. Then, the remainders will only consist of square-free monomials, so we can reduce Gaussian elimination to a submatrix of the Macaulay matrix whose columns are only indexed by square-free monomials. We discuss this approach and its complexity in Section 6. We also note that the reduction to square-free Macaulay matrices for polynomial systems $\mathcal{F} \subset \mathbb{F}_2[x_1, \dots, x_n]$ was already discussed by Bardet et al. [BFSS13]. Over \mathbb{F}_2 one can always include the field equations $F = (x_1^2 - x_1, \dots, x_n^2 - x_n)$ to restrict to the \mathbb{F}_2 -valued solutions of \mathcal{F} . Obviously, the complexity of division by remainder with respect to F is negligible compared to the cost of Gaussian elimination. This is not the case for our `Hydra` polynomial system, in particular a simple inequality reveals that for `Hydra` the auxiliary division by remainder step, i.e. the construction of square-free Macaulay matrices, dominates the complexity of DRL Gröbner basis computations (Equation (66)). In addition, to highlight the analogy from polynomial system solving over \mathbb{F}_2 , over an arbitrary field K we call square-free Macaulay matrices K -Boolean Macaulay matrices.

We implemented `Ciminion` and `Hydra` polynomial systems in the computer algebra sys-

tems SageMath [Sag24] and OSCAR [OSC24].¹ In particular, for Hydra we have implemented the linear system for the generic coordinates verification as well as the linear change of coordinates to produce a quadratic DRL Gröbner basis. We stress that our SageMath implementations is able to handle practical parameters like 128 bit prime numbers and full rounds Hydra with $r_{\mathcal{H}} = 39$.

Finally, in Section 7 we discuss how our results can be applied for cryptanalysis of Ciminion and Hydra.

- For Ciminion2, utilizing the DRL Gröbner basis the cost of solving for the first key pair is proportional to

$$\mathcal{O}\left(d^{\omega \cdot (r_C + r_E - 2) + 1}\right). \quad (2)$$

Let $64 \leq s \leq \log_2(q)$ denote the target security level of Ciminion, then one requires that $r_E \in \left\{s + 6, \left\lceil \frac{2 \cdot (s+6)}{3} \right\rceil\right\}$ [DGGK21, Table 1]. Since $\omega \geq 2$, this complexity will always exceed the target security level.

- For Hydra, extracting a zero-dimensional DRL Gröbner basis and solving via the Eigenvalue Method turns out to be the most competitive attack vector. In [GØSW23, §7.4] the Hydra designers claim that $r_{\mathcal{H}} = 31$ rounds are sufficient to achieve at least 128 bits of security against Gröbner basis attacks. Note that this claim is already invalidated if we perform term order conversion to LEX via the probabilistic FGLM algorithm. Via the Eigenvalue Method we can attack up to $r_{\mathcal{H}} = 33$ rounds below 128 bit complexity. However, Hydra with full rounds $r_{\mathcal{H}} = 39$ achieves 128 bits security against all strategies analyzed in this paper. Our complexities for various attack strategies on Hydra are summarized in Table 1.

Table 1: Summary of Hydra complexity estimations for various Gröbner basis attacks, see Tables 4 to 6. All computations are performed over the prime $q = 2^{127} + 45$ with $\omega = 2$.

$r_{\mathcal{H}}$	Eigenvalue Method	Term Order Conversion	Proven Solving Degree	Boolean Semi-Regular Estimate	Semi-Regular Estimate [GØSW23]
20	75	82	105	91	89
29	111	118	151	130	131
31	119	126	161	140	142
33	127	135	172	149	153
34	131	139	177	154	159
39	151	159	203	176	183

2 Preliminaries

We denote fields with K and their algebraic closure by \bar{K} . If the field and the number of variables are clear from context, then we abbreviate the polynomial ring as $P = K[x_1, \dots, x_n]$. Matrices $\mathbf{M} \in k^{m \times n}$ are denoted with upper bold letters and vectors $\mathbf{v} \in \mathbb{F}_q^n$ by lower bold letters. Matrix-vector and matrix-matrix products are written as $\mathbf{M}\mathbf{v}$.

For polynomial ideals $I \subset K[x_1, \dots, x_n]$, we denote the zero locus, i.e. its set of zeros, over \bar{k} as

$$\mathcal{Z}(I) = \{\mathbf{p} \in \bar{k}^n \mid f(\mathbf{p}) = 0, \forall f \in I\} \subset \mathbb{A}_{\bar{k}}^n. \quad (3)$$

¹<https://github.com/sca-research/Groebner-Basis-Cryptanalysis-of-Ciminion-and-Hydra.git>

For homogeneous ideals I we denote the projective zero locus over \bar{K} by $\mathcal{Z}_+(I) \subset \mathbb{P}_{\bar{K}}^{n-1}$.

Let $f \in K[x_1, \dots, x_n]$ be a polynomial, and let x_0 be an additional variable, the homogenization of f with respect to x_0 is defined as

$$f^{\text{hom}}(x_0, \dots, x_n) = x_0^{\deg(f)} \cdot f\left(\frac{x_1}{x_0}, \dots, \frac{x_n}{x_0}\right) \in K[x_0, \dots, x_n]. \quad (4)$$

Analog, we denote the homogenization of ideals $I^{\text{hom}} = \{f^{\text{hom}} \mid f \in I\}$ and of finite systems of polynomials $\mathcal{F}^{\text{hom}} = \{f_1^{\text{hom}}, \dots, f_m^{\text{hom}}\}$.

For a homogeneous ideal $I \subset P$ and an integer $d \geq 0$ we denote

$$I_d = \{f \in I \mid \deg(f) = d, f \text{ homogeneous}\}. \quad (5)$$

For a term order $>$ and an ideal $I \subset P$ we denote with $\text{in}_>(I) = \{\text{LT}_>(f) \mid f \in I\}$ the initial ideal of I , i.e. the ideal of leading terms of I , with respect to $>$.

Every polynomial $f \in K[x_1, \dots, x_n]$ of degree d can be written as $f = f_d + f_{d-1} + \dots + f_0$, where f_i is homogeneous of degree i . We denote its highest degree component f_d of f with f^{top} , and analog we denote $\mathcal{F}^{\text{top}} = \{f_1^{\text{top}}, \dots, f_m^{\text{top}}\}$. Note that

$$f^{\text{top}} = f^{\text{hom}} \pmod{(x_0)}. \quad (6)$$

Let $I, J \subset K[x_1, \dots, x_n]$ be ideals, then we denote with

$$I : J = \{f \in K[x_1, \dots, x_n] \mid \forall g \in J: f \cdot g \in I\} \quad (7)$$

the usual ideal quotient, and with

$$I : J^\infty = \bigcup_{i \geq 1} I : J^i \quad (8)$$

the saturation of I with respect to J .

Let $I, \mathfrak{m} \in K[x_0, \dots, x_n]$ be homogeneous ideals where $\mathfrak{m} = (x_0, \dots, x_n)$, then we call $I^{\text{sat}} = I : \mathfrak{m}^\infty$ the saturation of I .

Since we analyze vector-valued functions $F : \mathbb{F}_q^n \rightarrow \mathbb{F}_q^n$ we also denote vectors of polynomial ring variables as $\mathbf{x} = (x_1, \dots, x_n)^\top$. Moreover, for a term order $>$ on P , if not specified otherwise we always assume that the variables within a vector \mathbf{x} are naturally ordered with respect to $>$, i.e. $x_1 > \dots > x_n$.

We will often encounter the lexicographic and the degree reverse lexicographic term order which we will abbreviate as LEX and DRL respectively.

2.1 Ciminion

Let \mathbb{F}_q be a finite field, the Ciminion [DGGK21] PRF over \mathbb{F}_q is most easily described via an illustration, see Figure 1. A nonce $\mathfrak{N} \in \mathbb{F}_q$ and the first key pair (K_1, K_2) are fed into the permutation $p_C : \mathbb{F}_q^3 \rightarrow \mathbb{F}_q^3$. Then the outputs are fed into the permutation $p_E : \mathbb{F}_q^3 \rightarrow \mathbb{F}_q^3$. The first two outputs of p_E can then be added to messages $P_1, P_2 \in \mathbb{F}_q$ to encrypt them, and the third output remains private. If one wishes to encrypt an additional message pair $P_3, P_4 \in \mathbb{F}_q$ one feeds the outputs of p_C after a key addition with (K_3, K_4) into the rolling function $rol : \mathbb{F}_q^3 \rightarrow \mathbb{F}_q^3$ and then again into p_E .

The permutations p_C and p_E are based on an iterated Feistel network

$$\mathcal{R}^{(l)} : \mathbb{F}_q^3 \rightarrow \mathbb{F}_q^3, \quad \begin{pmatrix} x \\ y \\ z \end{pmatrix} \mapsto \begin{pmatrix} 0 & 0 & 1 \\ 1 & c_4^{(l)} & c_4^{(l)} \\ 0 & 1 & 1 \end{pmatrix} \begin{pmatrix} x \\ y \\ z + x \cdot y \end{pmatrix} + \begin{pmatrix} c_1^{(l)} \\ c_2^{(l)} \\ c_3^{(l)} \end{pmatrix}, \quad (9)$$

where $c_1^{(l)}, c_2^{(l)}, c_3^{(l)} \in \mathbb{F}_q$ and $c_4^{(l)} \in \mathbb{F}_q \setminus \{0, 1\}$. Note that the Feistel network $(x, y, z)^\top \mapsto (x, y, z + x \cdot y)^\top$ is also known as Toffoli gate which plays a special role in reversible computing [Tof80].

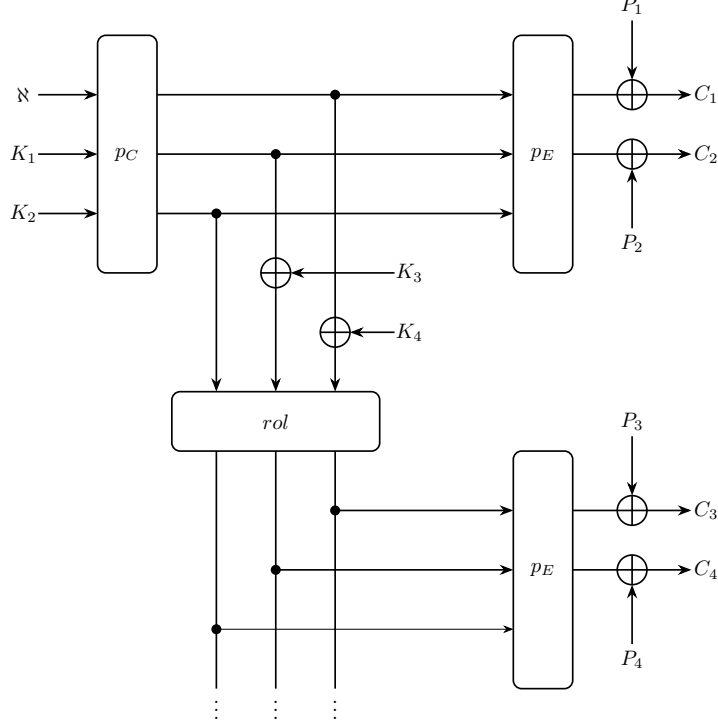

Figure 1: Encryption with Ciminion over a finite field \mathbb{F}_q .

The permutation p_C is defined as the r_C -fold composition of $\mathcal{R}^{(l)}$, and the function p_E is defined as the r_E -fold composition of $\mathcal{R}^{(l)}$. Finally, the rolling function is defined as

$$\begin{aligned} \text{rol} : \mathbb{F}_q^3 &\rightarrow \mathbb{F}_q^3, \\ \begin{pmatrix} x \\ y \\ z \end{pmatrix} &\mapsto \begin{pmatrix} z + x \cdot y \\ x \\ y \end{pmatrix}. \end{aligned} \quad (10)$$

Formulae to compute the round numbers for Ciminion are given in Table 2.

Table 2: Proposed round numbers for Ciminion [DGGK21, Table 1]. The security level s must satisfy $64 \leq s \leq \log_2(q)$, and $q \geq 2^{64}$.

Instance	p_C	p_E
Standard	$s + 6$	$\max \left\{ \left\lceil \frac{s+37}{12} \right\rceil, 6 \right\}$
Data limit $2^{\frac{s}{2}}$ elements	$\frac{2 \cdot (s+6)}{3}$	$\max \left\{ \left\lceil \frac{s+37}{12} \right\rceil, 6 \right\}$
Conservative	$s + 6$	$\max \left\{ \left\lceil \frac{3}{2} \cdot \frac{s+37}{12} \right\rceil, 9 \right\}$

E.g., for $s = 128$ and data limit $2^{\frac{s}{2}}$ we have the round numbers $r_C = 90$ and $r_E = 14$.

It is now straight-forward to set up the iterated polynomial system for the first key pair (K_1, K_2) given the first plain/ciphertext pair. For ease of writing we denote the i^{th} intermediate state variables as $\mathbf{x}_j^{(i)} = \left(x_{j,1}^{(i)}, x_{j,2}^{(i)}, x_{j,3}^{(i)} \right)^\top$ where $j \in \{C, E\}$.

Definition 2.1 (Iterated polynomial system for **Ciminion**). Let \mathbb{F}_q be a finite field, and let $(\aleph, (p_1, p_2), (c_1, c_2)) \in \mathbb{F}_q \times \mathbb{F}_q^2 \times \mathbb{F}_q^2$ be a nonce/plain/ciphertext sample given by a **Ciminion** encryption function. We call the polynomial system $\mathcal{F}_{\text{Ciminion}} = \{\mathbf{f}^{(i)}\}_{1 \leq i \leq r_C + r_E} \subset \mathbb{F}_q[y_1, y_2, \mathbf{x}_C^{(1)}, \dots, \mathbf{x}_C^{(r_C-1)}, \mathbf{x}_E^{(1)}, \dots, \mathbf{x}_E^{(r_E)}, x]$ the iterated **Ciminion** polynomial system

$$\mathbf{f}^{(i)} = \begin{cases} \mathcal{R}^{(1)}(\aleph, y_1, y_2) - \mathbf{x}_C^{(1)}, & i = 1, \\ \mathcal{R}^{(i)}(\mathbf{x}_C^{(i-1)}) - \mathbf{x}_C^{(i)}, & 2 \leq i \leq r_C - 1, \\ \mathcal{R}^{(i)}(\mathbf{x}_C^{(r_C-1)}) - \mathbf{x}_E^{(1)}, & i = r_C, \\ \mathcal{R}^{(i-r_C)}(\mathbf{x}_E^{(i-r_C)}) - \mathbf{x}_E^{(i-r_C+1)}, & r_C + 1 \leq i \leq r_C + r_E - 1, \\ \mathcal{R}^{(r_E)}(\mathbf{x}_E^{(r_E)}) - \begin{pmatrix} c_1 - p_1 \\ c_2 - p_2 \\ x \end{pmatrix}, & i = r_C + r_E. \end{cases}$$

2.2 Hydra

Let \mathbb{F}_q be a finite field, the **Hydra** [GOSW23] PRF over \mathbb{F}_q is most easily described via an illustration, see Figure 2. A nonce $\aleph \in \mathbb{F}_q$ and an initial value $\text{IV} \in \mathbb{F}_q^3$ are added to a key $\mathbf{K} \in \mathbb{F}_q^4$, and then fed into the keyed *body* function $\mathcal{B} : \mathbb{F}_q^4 \times \mathbb{F}_q^4 \rightarrow \mathbb{F}_q^8$ which produces the state $\mathbf{y}||\mathbf{z} = (\mathbf{y}, \mathbf{z})^\top \in \mathbb{F}_q^4 \times \mathbb{F}_q^4$. Then $\mathbf{y}||\mathbf{z}$ is fed into the first keyed *head* function $\mathcal{H}_\mathbf{K} : \mathbb{F}_q^8 \times \mathbb{F}_q^4 \rightarrow \mathbb{F}_q^8$. After adding $\mathbf{y}||\mathbf{z}$ to the output of the head the result is released as the first **Hydra** sample. Say one has already requested $(i-1)$ **Hydra** samples, for an additional sample $\mathbf{y}||\mathbf{z}$ is fed into the i^{th} rolling function $\mathcal{R}_i : \mathbb{F}_q^8 \rightarrow \mathbb{F}_q^8$, and then again into the head $\mathcal{H}_\mathbf{K}$. After adding the output of \mathcal{R}_i to the output of $\mathcal{H}_\mathbf{K}$ the result is released as i^{th} **Hydra** sample.

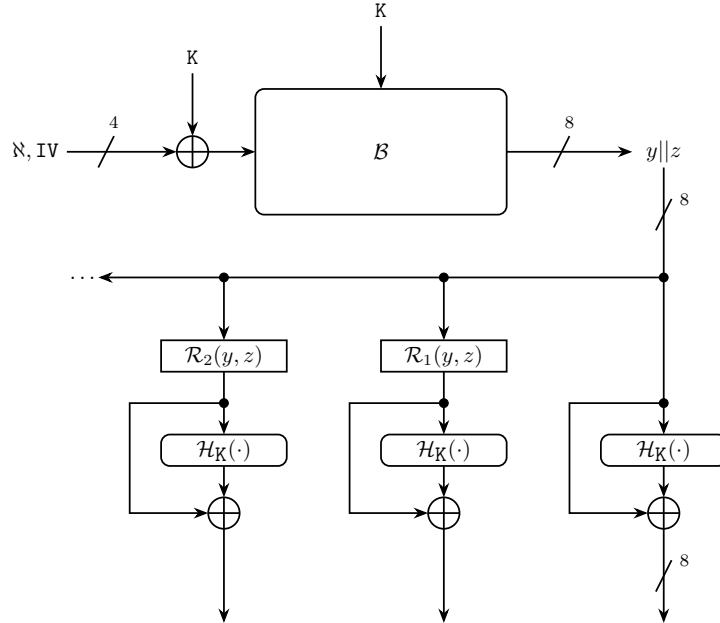

Figure 2: The Hydra PRF with hidden body.

For our polynomial model we are only going to consider the heads of the **Hydra**. Thus, we do not describe the details of the body function \mathcal{B} , interested readers can find the

description in [GØSW23, §5.2]. Let $\mathbf{M}_{\mathcal{E}} \in \text{GL}_4(\mathbb{F}_q)$ be an MDS matrix, e.g. the Hydra designers recommend $\text{circ}(2, 3, 1, 1)$ or $\text{circ}(3, 2, 1, 1)^2$. For the keyed permutation \mathcal{H}_K , let

$$K' = \begin{pmatrix} K \\ \mathbf{M}_{\mathcal{E}}K \end{pmatrix} \in \mathbb{F}_q^8, \quad (11)$$

$$f(\mathbf{x}) = \left(\sum_{i=1}^8 (-1)^{\lfloor \frac{i-1}{4} \rfloor} \cdot x_i \right)^2. \quad (12)$$

Moreover, let $\mathbf{M}_{\mathcal{J}} \in \text{GL}_8(\mathbb{F}_q)$ be an invertible matrix. Then the heads round function is defined as

$$\begin{aligned} \mathcal{J}_i : \mathbb{F}_q^8 \times \mathbb{F}_q^4 &\rightarrow \mathbb{F}_q^8, \\ (\mathbf{x}, K) &\mapsto \mathbf{M}_{\mathcal{J}}(x_i + f(\mathbf{x}))_{1 \leq i \leq 8} + K' + \mathbf{c}^{(i)}, \end{aligned} \quad (13)$$

where $\mathbf{c}^{(i)} \in \mathbb{F}_q^8$ is a constant. The heads function is now defined as the following $r_{\mathcal{H}}$ -fold composition

$$\begin{aligned} \mathcal{H}_K : \mathbb{F}_q^4 \times \mathbb{F}_q^4 \times \mathbb{F}_q^4 &\rightarrow \mathbb{F}_q^8, \\ (\mathbf{y}, \mathbf{z}, K) &\mapsto \mathcal{J}_{r_{\mathcal{H}}} \circ \dots \circ \mathcal{J}_1 \left(\begin{pmatrix} \mathbf{y} \\ \mathbf{z} \end{pmatrix}, K \right). \end{aligned} \quad (14)$$

Let $\mathbf{M}_{\mathcal{I}} \in \text{GL}_4(\mathbb{F}_q)$ be a matrix of the form

$$\mathbf{M}_{\mathcal{I}} = \begin{pmatrix} \mu_{1,1} & 1 & 1 & 1 \\ \mu_{2,1} & \mu_{2,2} & 1 & 1 \\ \mu_{3,1} & 1 & \mu_{3,3} & 1 \\ \mu_{4,1} & 1 & 1 & \mu_{4,4} \end{pmatrix}. \quad (15)$$

Finally, for the rolling function let

$$g(\mathbf{y}, \mathbf{z}) = \left(\sum_{i=1}^4 (-1)^{i-1} \cdot y_i \right) \cdot \left(\sum_{i=1}^4 (-1)^{\lfloor \frac{i-1}{2} \rfloor} \cdot z_i \right), \quad (16)$$

$$\mathbf{M}_{\mathcal{R}} = \text{diag}(\mathbf{M}_{\mathcal{I}}, \mathbf{M}_{\mathcal{I}}). \quad (17)$$

Then, the rolling function is defined as

$$\begin{aligned} \mathcal{R} : \mathbb{F}_q^4 \times \mathbb{F}_q^4 &\rightarrow \mathbb{F}_q^8, \\ \begin{pmatrix} \mathbf{y} \\ \mathbf{z} \end{pmatrix} &\mapsto \mathbf{M}_{\mathcal{R}} \left(\begin{matrix} \{y_i + g(\mathbf{y}, \mathbf{z})\}_{1 \leq i \leq 4} \\ \{z_i + g(\mathbf{z}, \mathbf{y})\}_{1 \leq i \leq 4} \end{matrix} \right), \end{aligned} \quad (18)$$

and the i^{th} rolling function is simply the i -fold composition $\mathcal{R}_i = \mathcal{R} \circ \dots \circ \mathcal{R}$. Note that the degree increasing parts in \mathcal{J}_i and \mathcal{R} are generalized Lai–Massey permutations [RS22].

For κ bits of security, the number of rounds for the Hydra heads with data limit $2^{\frac{\kappa}{2}}$ are computed via, see [GØSW23, §5.5],

$$r_{\mathcal{H}} = \lceil 1.25 \cdot \max \{24, 2 + r_{\mathcal{H}}^*\} \rceil, \quad (19)$$

²We consider circulant matrices with respect to a right shift, i.e.

$$\text{circ}(a_1, \dots, a_n) = \begin{pmatrix} a_1 & a_2 & \dots & a_{n-1} & a_n \\ a_n & a_1 & \dots & a_{n-2} & a_{n-1} \\ \vdots & \vdots & \ddots & \vdots & \vdots \\ a_2 & a_3 & \dots & a_n & a_1 \end{pmatrix}.$$

where $r_{\mathcal{H}}^*$ is the smallest integer that satisfies [GØSW23, Equation 12] and [GØSW22, Equation 15]. Note that [GØSW23, Equation 12] is derived from the Gröbner basis cryptanalysis of Hydra. E.g., for $q = 2^{127} + 45$ and $\kappa = 128$ the Hydra designers propose $r_{\mathcal{H}} = 39$.

Given two Hydra outputs it is straight-forward to set up an overdetermined polynomial system for Hydra. For ease of writing we denote the i^{th} intermediate state variables for the j^{th} output as $\mathbf{x}_j^{(i)} = (x_{j,1}^{(i)}, \dots, x_{j,8}^{(i)})^{\top}$ and analog for $\mathbf{y} = (y_1, \dots, y_4)^{\top}$, $\mathbf{z} = (z_1, \dots, z_4)^{\top}$ and $\mathbf{k} = (k_1, \dots, k_4)^{\top}$.

Definition 2.2 (Iterated polynomial system for Hydra). *Let \mathbb{F}_q be a finite field, and let $\mathbf{c}_1, \mathbf{c}_2 \in \mathbb{F}_q^8$ be the first two outputs of a Hydra function. We call the following polynomial system $\mathcal{F}_{\text{Hydra}} = \left\{ \mathbf{f}_1^{(i)}, \mathbf{f}_{\mathcal{R}}, \mathbf{f}_2^{(i)} \right\}_{1 \leq i \leq r_{\mathcal{H}}} \subset \mathbb{F}_q[\mathbf{y}, \mathbf{z}, \mathbf{x}_1^{(1)}, \dots, \mathbf{x}_1^{(r_{\mathcal{H}}-1)}, \mathbf{x}_2^{(0)}, \dots, \mathbf{x}_2^{(r_{\mathcal{H}}-1)}, \mathbf{k}]$ the iterated Hydra polynomial system*

$$\mathbf{f}_1^{(i)} = \begin{cases} \mathcal{J}_1 \left(\begin{pmatrix} \mathbf{y} \\ \mathbf{z} \end{pmatrix}, \mathbf{k}' \right) - \mathbf{x}_1^{(1)}, & i = 1, \\ \mathcal{J}_i \left(\mathbf{x}_1^{(i-1)}, \mathbf{k}' \right) - \mathbf{x}_1^{(i)}, & 2 \leq i \leq r_{\mathcal{H}} - 1, \\ \mathcal{J}_{r_{\mathcal{H}}} \left(\mathbf{x}_1^{(r_{\mathcal{H}}-1)}, \mathbf{k}' \right) + \begin{pmatrix} \mathbf{y} \\ \mathbf{z} \end{pmatrix} - \mathbf{c}_1, & i = r_{\mathcal{H}}, \end{cases}$$

$$\mathbf{f}_{\mathcal{R}} = \mathcal{R} \left(\begin{pmatrix} \mathbf{y} \\ \mathbf{z} \end{pmatrix} \right) - \mathbf{x}_2^{(0)},$$

$$\mathbf{f}_2^{(i)} = \begin{cases} \mathcal{J}_1 \left(\mathbf{x}_2^{(0)}, \mathbf{k}' \right) - \mathbf{x}_2^{(1)}, & i = 1, \\ \mathcal{J}_i \left(\mathbf{x}_2^{(i-1)}, \mathbf{k}' \right) - \mathbf{x}_2^{(i)}, & 2 \leq i \leq r_{\mathcal{H}} - 1, \\ \mathcal{J}_{r_{\mathcal{H}}} \left(\mathbf{x}_2^{(r_{\mathcal{H}}-1)}, \mathbf{k}' \right) + \mathbf{x}_2^{(1)} - \mathbf{c}_2, & i = r_{\mathcal{H}}, \end{cases}$$

where $\mathbf{k}' = \begin{pmatrix} \mathbf{k} \\ \mathbf{M}_{\mathcal{E}} \mathbf{k} \end{pmatrix}$.

This polynomial system consists of $16 \cdot r_{\mathcal{H}} + 8$ many polynomials in $16 \cdot r_{\mathcal{H}} + 4$ many variables. It can also easily be expanded to an arbitrary number of output samples.

2.3 Gröbner Bases

Gröbner bases are a fundamental tool in computational algebra. They were first introduced by Bruno Buchberger in his PhD thesis [Buc65]. For their definition one needs to induce an order on the monomials of a polynomial ring $P = K[x_1, \dots, x_n]$. First notice that a monomial $m = \prod_{i=1}^n x_i^{a_i} \in P$ can be identified with its exponent vector $\mathbf{a} = (a_1, \dots, a_n)^{\top} \in \mathbb{Z}_{\geq 0}^n$. Therefore, a term order $>$ on P is a binary relation on $\mathbb{Z}_{\geq 0}^n$ such that, see [CLO15, Chapter 2 §2 Definition 1]:

- (i) $>$ is a total ordering in $\mathbb{Z}_{\geq 0}^n$.
- (ii) If $\mathbf{a} > \mathbf{b}$ and $\mathbf{c} \in \mathbb{Z}_{\geq 0}^n$, then $\mathbf{a} + \mathbf{c} > \mathbf{b} + \mathbf{c}$.
- (iii) Every non-empty subset of $\mathbb{Z}_{\geq 0}^n$ has a smallest element under $>$, i.e. $>$ is a well-ordering on $\mathbb{Z}_{\geq 0}^n$.

Now let $I \subset P = K[x_1, \dots, x_n]$ be an ideal, and let $f \in P$. By $\text{LM}_{>}(f)$ we denote the leading monomial of f , i.e. the largest monomial with non-zero coefficient in f under $>$. A finite ideal basis $\mathcal{G} = \{g_1, \dots, g_m\} \subset I$ such that

$$(\text{LM}_{>}(g_1), \dots, \text{LM}_{>}(g_m)) = \text{in}_{>}(I) \quad (20)$$

is called a $>$ -Gröbner basis of I . I.e., the leading monomials of \mathcal{G} are minimal under $>$. With Gröbner bases one can solve many important computational problems like the membership problem or the computation of the zero locus. For a general introduction to Gröbner bases we refer to [KR00, KR05, CLO15].

2.3.1 Linear Algebra-Based Gröbner Basis Algorithms

The first algorithm to compute Gröbner bases was *Buchberger's algorithm*, see e.g. [CLO15, Chapter 2 §7]. Given an input polynomial system $\mathcal{F} \subset P = k[x_1, \dots, x_n]$ and a term order $>$ on P , Buchberger's algorithm performs pairwise cancellation of the leading monomials under $>$ of two elements in \mathcal{F} followed by multivariate division by remainder. If a non-zero element is produced, then it is added to \mathcal{F} and the process is repeated. Buchberger proved that this procedure terminates and produces a $>$ -Gröbner basis.

Lazard [Laz83] generalized this construction by performing multiple leading term cancellations and reductions at the same time via a matrix representation of the polynomial system \mathcal{F} . Assume that $\mathcal{F} = \{f_1, \dots, f_m\} \subset P$ is homogeneous and fix a term order $>$ on P . The *homogeneous Macaulay matrix* M_d for \mathcal{F} has columns indexed by the monomials of degree d in P sorted via $>$, and its rows are indexed by $s \cdot f$, where $f \in \mathcal{F}$ and $s \in P$ is a monomial such that $\deg(s \cdot f) = d$. The entry of row $s \cdot f$ at column t is the coefficient of t in the polynomial $s \cdot f$. If \mathcal{F} is inhomogeneous, then one replaces the degree equalities by inequalities to obtain the *inhomogeneous Macaulay matrix* $M_{\leq d}$.

Obviously, if we perform Gaussian elimination on M_0, \dots, M_d respectively $M_{\leq d}$ for a large enough value of d , then we construct a $>$ -Gröbner basis for \mathcal{F} . The least such d is called the *solving degree*, to the best of our knowledge this notion was first introduced in [DS13].

Definition 2.3 (Solving degree, [CG21, Definition 6]). *Let $\mathcal{F} = \{f_1, \dots, f_m\} \subset K[x_1, \dots, x_n]$ and let $>$ be a term order. The solving degree of \mathcal{F} is the least degree d such that Gaussian elimination on the Macaulay matrix $M_{\leq d}$ produces a Gröbner basis of \mathcal{F} with respect to $>$. We denote it by $\text{sd}_{>}(\mathcal{F})$.*

If \mathcal{F} is homogeneous, we consider the homogeneous Macaulay matrix M_d and let the solving degree of \mathcal{F} be the least degree d such that Gaussian elimination on M_0, \dots, M_d produces a Gröbner basis of \mathcal{F} with respect to $>$.

By [CG21, Theorem 7] the homogeneous solving degree always upper bounds the inhomogeneous one, i.e.

$$\text{sd}_{DRL}(\mathcal{F}) \leq \text{sd}_{DRL}(\mathcal{F}^{\text{hom}}). \quad (21)$$

Algorithms which perform Gaussian elimination on the Macaulay matrices are generally referred to as *linear algebra-based Gröbner basis algorithms*. Modern examples of such algorithms are Faugère's F4 [Fau99] and Matrix-F5 [Fau02] algorithms. Since the solving degree is a priori unknown for most polynomial system, F4/5 construct the Macaulay matrices and perform Gaussian elimination for increasing values of d . Therefore, they require a stopping criterion to decide whether a Gröbner basis has already been found. On the other hand, we can always stop F4/5 after the final Gaussian elimination in the solving degree, since the row space basis must already contain a Gröbner basis. For this reason, we also consider the solving degree as complexity measure for advanced linear algebra-based algorithms.

2.3.2 Complexity Estimates via the Solving Degree

It is well-known that the complexity of Gaussian elimination of a matrix $\mathbf{A} \in K^{n \times m}$, where K is a field and $r = \text{rank}(\mathbf{A})$, is given by [Sto00, §2.2] $\mathcal{O}(n \cdot m \cdot r^{\omega-2})$ field operations, where $2 \leq \omega < 2.37286$ is a linear algebra constant [AW21].

Given a homogeneous polynomial system $\mathcal{F} = \{f_1, \dots, f_m\} \subset P = K[x_1, \dots, x_n]$, it is well-known that the number of monomials in P of degree d is $\binom{n+d-1}{d}$. Moreover, for $f \in \mathcal{F}$ the number of rows $\hat{m} \cdot f$, where $\hat{m} \in P$ a monomial such that $\deg(\hat{m} \cdot f) = d$, is also bounded by $\binom{n+d-1}{d}$. Thus, the complexity of Gaussian elimination on the homogeneous Macaulay matrices M_0, \dots, M_d is bounded by

$$\mathcal{O} \left(m \cdot d \cdot \binom{n+d-1}{d}^\omega \right). \quad (22)$$

Also, note that dehomogenization of a Gröbner basis yields an inhomogeneous Gröbner basis [KR05, Proposition 4.3.18] (if the term order is compatible with homogenization). Therefore, we can also regard Equation (22) as complexity estimate for Gaussian elimination on the inhomogeneous Macaulay matrix $M_{\leq d}$.

2.4 Generic Coordinates

Caminata & Gorla [CG23] have proven that for a special class of polynomial systems the DRL solving degree is always upper bounded by the so-called *Macaulay bound*. They called these polynomial *to be in generic coordinates*. For the formal definition of this notion, we use the shorthand notation “ $r \nmid 0 \pmod{I}$ ” for expressing that r is not a zero-divisor in P/I . Moreover, we always assume that the homogenization variable x_0 is the least variable under DRL.

Definition 2.4 ([CG21, CG22, Definition 5]). *Let K be an infinite field. Let $I \subset K[x_0, \dots, x_n]$ be a homogeneous ideal with $|\mathcal{Z}_+(I)| < \infty$. We say that I is in generic coordinates if either $|\mathcal{Z}_+(I)| = 0$ or $x_0 \nmid 0 \pmod{I^{\text{sat}}}$.*

Let K be any field, and let $K \subset L$ be an infinite field extension. I is in generic coordinates over K if $I \otimes_K L[x_0, \dots, x_n] \subset L[x_0, \dots, x_n]$ is in generic coordinates.

As already mentioned, polynomial systems in generic coordinates have a proven DRL solving degree upper bound.

Theorem 2.5 ([CG21, Theorem 9, 10, Corollary 2]). *Let K be an algebraically closed field, and let $\mathcal{F} = \{f_1, \dots, f_m\} \subset K[x_1, \dots, x_n]$ be an inhomogeneous polynomial system such that $(\mathcal{F}^{\text{hom}})$ is in generic coordinates. Let $d_i = \deg(f_i)$ and assume that $d_1 \geq \dots \geq d_m$, then for $l \in \min\{n+1, m\}$*

$$\text{sd}_{\text{DRL}}(\mathcal{F}) \leq d_1 + \dots + d_l - l + 1.$$

In the Gröbner basis and algebraic cryptanalysis literature the latter inequality is also usually referred as Macaulay bound. Moreover, Lazard [Laz83] first observed that DRL Gröbner bases for “generic” polynomial systems can be found within the Macaulay bound.

Finally, being in generic coordinates was recently characterized by Steiner [Ste24].

Theorem 2.6 ([Ste24, Theorem 3.2]). *Let K be an algebraically closed field, and let $\mathcal{F} = \{f_1, \dots, f_m\} \subset K[x_1, \dots, x_n]$ be a polynomial system such that*

- (i) $(\mathcal{F}) \neq (1)$, and
- (ii) $\dim(\mathcal{F}) = 0$.

Then the following are equivalent.

- (1) $(\mathcal{F}^{\text{hom}})$ is in generic coordinates.
- (2) $\sqrt{\mathcal{F}^{\text{top}}} = (x_1, \dots, x_n)$.

(3) $(\mathcal{F}^{\text{top}})$ is zero-dimensional in $K[x_1, \dots, x_n]$.

(4) For every $1 \leq i \leq n$ there exists $d_i \in \mathbb{Z}_{\geq 1}$ such that $x_i^{d_i} \in \text{in}_{\text{DRL}}(\mathcal{F}^{\text{hom}})$.

Let $\mathcal{F} \subset K[x_1, \dots, x_n]$ be an inhomogeneous polynomial system, to prove that \mathcal{F}^{hom} is in generic coordinates one can use the following procedure based on (2):

- (1) Compute $(\mathcal{F}^{\text{top}}) = (\mathcal{F}^{\text{hom}}) \bmod (x_0)$.
- (2) Construct a monomial $x_i^d \in (\mathcal{F}^{\text{top}})$ for some $1 \leq i \leq n$ and $d \geq 1$.
- (3) Replace $(\mathcal{F}^{\text{top}}) = (\mathcal{F}^{\text{top}}) \bmod (x_i)$ and return to step (2).

If Step (2) is successful for all $1 \leq i \leq n$, then the polynomial system \mathcal{F}^{hom} is in generic coordinates.

Another quantity in the literature that is often used to express the complexity of finding a DRL Gröbner basis is the so-called *degree of regularity*.

Definition 2.7 (Degree of regularity, [BFS04, Definition 4]). *Let K be a field, and let $\mathcal{F} \subset P = K[x_1, \dots, x_n]$. Assume that $(\mathcal{F}^{\text{top}})_d = P_d$ for some integer $d \geq 0$. The degree of regularity is defined as*

$$d_{\text{reg}}(\mathcal{F}) = \min \{d \geq 0 \mid (\mathcal{F}^{\text{top}})_d = P_d\}.$$

Note that by Theorem 2.6 a polynomial system is in generic coordinates if and only if it admits a finite degree of regularity.

2.5 The Eigenvalue Method

As outlined in the introduction, in the algebraic cryptanalysis literature the standard approach to polynomial system solving is

- (1) DRL Gröbner basis computation,
- (2) term order conversion to LEX, and
- (3) univariate factoring.

In this section we shortly discuss that there is an alternative to term order conversion via linear algebra-based techniques [KR16, Chapter 6]. Our motivation to change the strategy is quite simple. Via the Eigenvalue Method we will be able to exploit the *multiplicative structure* of Ciminion and Hydra DRL Gröbner bases. Consequently, this will provide a slight improvement compared to the generic complexity of the probabilistic FGLM algorithm [FGHR14].

Let $I \subset P = K[x_1, \dots, x_n]$ be a zero-dimensional ideal, i.e. P/I is a finite dimensional K -vector space [KR00, Proposition 3.7.1], and let $d = \dim_K(P/I)$. If $>$ is a term order on P and $\mathcal{G} \subset I$ is $>$ -Gröbner basis, then a K -vector space basis \mathcal{B} of P/I is given by the monomials not contained in $\text{in}_{>}(\mathcal{G}) = \text{in}_{>}(I)$. Now let $f \in P$, then the multiplication map

$$\begin{aligned} \theta_f : P &\rightarrow P/I, \\ x &\mapsto x \cdot f, \end{aligned} \tag{23}$$

can be represented via a matrix. This matrix is called the multiplication matrix \mathbf{M}_f for f . Given a $>$ -Gröbner basis its computation is straight-forward: Index the columns of \mathbf{M}_f by the K -vector space basis \mathcal{B} , and the rows by $b \cdot f$, where $b \in \mathcal{B}$. The row $b \cdot f$ is then simply the coefficient vector of $b \cdot f$ in P/I which can be computed via $b \cdot f \bmod (\mathcal{G})$ with respect to $>$.

Now assume in addition that K is algebraically closed, then for every point $\mathbf{x} \in \mathcal{Z}(I)$ the point $f(\mathbf{x})$ is an eigenvalue of \mathbf{M}_f , see [KR16, Proposition 6.2.1]. Therefore, we can compute the zero locus $\mathcal{Z}(I)$ as follows: Compute the eigenvalues of $\mathbf{M}_{x_1}, \dots, \mathbf{M}_{x_n}$, iterate over all possible combinations, and verify whether a combination is indeed a solution to I . This approach is known as *Eigenvalue Method* [KR16, §6.2.A].

In his seminal work Strassen showed that matrix inversion, determinant and Gaussian elimination have the same complexity as matrix multiplication up to some constant [Str69]. For the determinant this observation follows from LU-decomposition of block square matrices. We recall this decomposition since we will exploit it at a later point in this paper. Let $\mathbf{A}, \mathbf{B}, \mathbf{C}, \mathbf{D} \in K^{2 \cdot N \times 2 \cdot N}$ be matrices, then we have the block matrix decomposition

$$\begin{pmatrix} \mathbf{A} & \mathbf{B} \\ \mathbf{C} & \mathbf{D} \end{pmatrix} = \begin{pmatrix} \mathbf{I}_{N \times N} & \mathbf{0}_{N \times N} \\ \mathbf{C}\mathbf{A}^{-1} & \mathbf{I}_{N \times N} \end{pmatrix} \begin{pmatrix} \mathbf{A} & \mathbf{B} \\ \mathbf{0}_{N \times N} & \mathbf{D} - \mathbf{C}\mathbf{A}^{-1}\mathbf{B} \end{pmatrix}, \quad (24)$$

provided that \mathbf{A} is invertible. With well-known formulae for block matrix determinants, see e.g. [Sil00], one then has that

$$\det \begin{pmatrix} \mathbf{A} & \mathbf{B} \\ \mathbf{C} & \mathbf{D} \end{pmatrix} = \det(\mathbf{A}) \cdot \det(\mathbf{D} - \mathbf{C}\mathbf{A}^{-1}\mathbf{B}). \quad (25)$$

So the determinant of the block matrix has been reduced to two determinants of smaller matrices, one matrix inversion and two matrix multiplications. By Strassen [Str69] the complexity of multiplying two $N \times N$ matrices is in $\mathcal{O}(N^{\omega+o(1)})$, where $2 \leq \omega < 2.37286$ is again the linear algebra constant [AW21]. Note that the term $N^{o(1)}$ is usually ignored in complexity estimations.

Lastly, it is well known that the eigenvalues of a matrix $\mathbf{M} \in K^{N \times N}$ are roots of its characteristic polynomial

$$\chi_{\mathbf{M}}(x) = \det(\mathbf{I}_{N \times N} \cdot x - \mathbf{M}) \in K[x]. \quad (26)$$

Therefore, construction of the characteristic polynomials in the Eigenvalue Method can be performed in

$$\mathcal{O}(n \cdot d^\omega), \quad (27)$$

where $d = \dim_K(P/I)$. In addition, if we are only interested in solutions over a finite field \mathbb{F}_q , then factorization of the characteristic polynomials can be done via the GCD with the field equation whose complexity was given in Equation (1).

Note that the probabilistic FGLM algorithm [FGHR14, Proposition 3] has polylogarithmic complexity $\tilde{\mathcal{O}}(d^\omega)$ for the construction of a LEX Gröbner basis of I if I is in shape position, and polylogarithmic complexity $\tilde{\mathcal{O}}(n \cdot d^\omega)$ for the construction of a LEX Gröbner basis of \sqrt{I} , which applies to any ideal not in shape position. This is no coincidence, the probabilistic FGLM algorithm constructs a LEX Gröbner basis via the multiplication matrix for the last variable. Hence, for both methods the complexity is dominated by $\mathcal{O}(d^\omega)$.

3 Analysis of Ciminion

At round level **Ciminion** is a three branch Feistel network. In [Ste24, §4.1] a DRL Gröbner basis for Feistel- $2n/n$ polynomial systems has been computed by substituting the linear branches into the non-linear ones. In principle, we are going to replicate this strategy to construct a DRL Gröbner basis for **Ciminion**.

3.1 A DRL Gröbner Basis for Ciminon

For simplicity let us denote the matrix in the i^{th} Ciminon round by $\mathbf{A}_i \in \mathbb{F}_q^{3 \times 3}$, then

$$\mathbf{A}_i^{-1} = \begin{pmatrix} 0 & 1 & -c_4^{(i)} \\ -1 & 0 & 1 \\ 1 & 0 & 0 \end{pmatrix}, \quad (28)$$

where $c_4^{(i)} \notin \mathbb{F}_q \setminus \{0, 1\}$.

Theorem 3.1. *Let \mathbb{F}_q be a finite field, and let*

$$\mathcal{F}_{\text{Ciminon}} = \{\mathbf{f}^{(1)}, \dots, \mathbf{f}^{(r_C+r_E)}\} \subset \mathbb{F}_q \left[y_1, y_2, \mathbf{x}_C^{(1)}, \dots, \mathbf{x}_C^{(r_C-1)}, \mathbf{x}_E^{(1)}, \dots, \mathbf{x}_E^{(r_E)}, x \right]$$

be a Ciminon polynomial system. For the DRL term order $y_1 > y_2 > \mathbf{x}_C^{(1)} > \dots > \mathbf{x}_C^{(r_C-1)} > \mathbf{x}_E^{(1)} > \mathbf{x}_E^{(r_E)} > x$, the following procedure computes a DRL Gröbner basis for Ciminon:

- (1) For every round $1 \leq i \leq r_C + r_E$ compute $\mathbf{g}^{(i)} = \mathbf{A}_i^{-1} \mathbf{g}_i$.
- (2) Collect the linear polynomials from the $\mathbf{g}^{(i)}$'s in \mathcal{L} , and perform Gaussian elimination on \mathcal{L} .
- (3) Reduce the non-linear polynomials in the $\mathbf{g}^{(i)}$'s modulo \mathcal{L} .

Proof. By inspection of the round function (Equation (9)) we have that

$$\mathbf{g}^{(1)} = \begin{pmatrix} \aleph \\ y_1 \\ y_2 + \aleph \cdot y_1 \end{pmatrix} + \mathbf{A}_1^{-1} \left(\mathbf{c}^{(1)} - \mathbf{x}_C^{(1)} \right), \quad (29)$$

$$\mathbf{g}^{(i)} = \begin{pmatrix} x_{C,1}^{(i-1)} \\ x_{C,2}^{(i-1)} \\ x_{C,3}^{(i-1)} + x_{C,1}^{(i-1)} \cdot x_{C,2}^{(i-1)} \end{pmatrix} + \mathbf{A}_i^{-1} \left(\mathbf{c}^{(i)} - \begin{pmatrix} x_{C,1}^{(i)} \\ x_{C,2}^{(i)} \\ x_{C,3}^{(i)} \end{pmatrix} \right), \quad (30)$$

$$\mathbf{g}^{(r_C+r_E)} = \begin{pmatrix} x_{E,1}^{(r_E)} \\ x_{E,2}^{(r_E)} \\ x_{E,3}^{(r_E)} + x_{E,1}^{(r_E)} \cdot x_{C,2}^{(r_E)} \end{pmatrix} + \mathbf{A}_i^{-1} \left(\mathbf{c}^{(r_E)} - \begin{pmatrix} c_1 - p_1 \\ c_2 - p_2 \\ x \end{pmatrix} \right), \quad (31)$$

and analog for the equations involving the $\mathbf{x}_E^{(i)}$'s. Hence, \mathcal{L} contains $\mathbf{g}^{(1)}$ and the first two components of all remaining $\mathbf{g}^{(i)}$'s.

For Gaussian elimination on \mathcal{L} let us start in the last round $i = r_C + r_E$. By construction and Equation (28) the linear polynomials with leading monomials $x_{E,1}^{(r_E)}, x_{E,2}^{(r_E)}$ contain a linear term in x and a constant term. Moving to $i = r_C + r_E - 1$ next, then the linear polynomials from $\mathbf{g}^{(r_C+r_E-1)}$ depend on $\mathbf{x}_E^{(r_C+r_E-1)}$ and $\mathbf{x}_E^{(r_C+r_E)}$, via Gaussian elimination the variables $x_{E,1}^{(r_E)}$ and $x_{E,2}^{(r_E)}$ get eliminated. Thus, the linear polynomials with leading monomials in $x_{E,1}^{(r_E-1)}, x_{E,2}^{(r_E-1)}$ can only depend on $x_{E,3}^{(r_E)}$ and x . Moreover, by Equation (28) the coefficients for $x_{E,3}^{(r_E)}$ are non-zero. Via a downwards induction we can then conclude that the linear polynomials with leading monomials $x_{*,1}^{(i)}, x_{*,2}^{(i)}$ only depend on the variables $x_{*,3}^{(i+1)}, \dots, x_{E,3}^{(r_E)}, x$ and that the coefficients of $x_{*,3}^{(i+1)}$ are non-zero. The

first round needs special care since the first row of \mathbf{A}_1^{-1} is non-zero on the variable $x_{C,2}^{(1)}$. (If it were zero on $x_{C,1}^{(1)}$ and $x_{C,2}^{(1)}$, the first polynomial in $\mathbf{g}^{(1)}$ would have leading monomial $x_{C,3}^{(1)}$ and the proof would be finished.) Expansion of Equation (29) yields

$$\mathbf{g}^{(1)} = \begin{pmatrix} \aleph \\ y_1 \\ y_2 + \aleph \cdot y_1 \end{pmatrix} + \mathbf{A}_1^{-1} \mathbf{c}_1 - \begin{pmatrix} x_{C,2}^{(1)} - c_4^{(1)} \cdot x_{C,3}^{(1)} \\ -x_{C,1}^{(1)} + x_{C,3}^{(1)} \\ x_{C,1}^{(1)} \end{pmatrix}.$$

Producing a polynomial with leading monomial y_2 is straight-forward, we simply have to take $g_3^{(1)} - \aleph \cdot g_2^{(1)}$. Note that there is second polynomial with leading monomial $x_{C,2}^{(1)}$ after inversion of the matrices

$$g_2^{(2)} = x_{C,2}^{(1)} + \left(\mathbf{A}_2^{-1} \mathbf{c}^{(2)} \right)_2 - \left(-x_{C,1}^{(2)} + x_{C,3}^{(2)} \right).$$

Then

$$g_1^{(1)} + g_2^{(2)} = \aleph + \left(\mathbf{A}_1^{-1} \mathbf{c}^{(1)} \right)_1 + c_4^{(1)} \cdot x_{C,3}^{(1)} + \left(\mathbf{A}_2^{-1} \mathbf{c}^{(2)} \right)_2 + x_{C,1}^{(2)} - x_{C,3}^{(2)},$$

and by the choice of our DRL term order and $c_4^{(1)} \neq 0$ this polynomial has leading monomial $x_{C,3}^{(1)}$. Obviously, after Gaussian elimination of \mathcal{L} the terms of $g_1^{(1)} + g_2^{(2)}$, $g_2^{(1)}$, $g_3^{(1)} - \aleph \cdot g_2^{(1)}$ after the leading monomials will also only depend on the variables $x_{C,3}^{(2)}, \dots, x_{E,3}^{(r_E)}, x$.

Lastly, let us consider the reduction modulo \mathcal{L} . By our previous observations all linear equations are of the form

$$\begin{aligned} y_1 + \mathcal{A}_1 \left(x_{C,3}^{(2)}, \dots, x_{E,3}^{(r_C+r_E-1)}, x \right) &= 0, \\ y_2 + \mathcal{A}_2 \left(x_{C,3}^{(2)}, \dots, x_{E,3}^{(r_C+r_E-1)}, x \right) &= 0, \\ x_{E,3}^{(1)} + \mathcal{A}_3 \left(x_{C,3}^{(2)}, \dots, x_{E,3}^{(r_C+r_E-1)}, x \right) &= 0, \\ x_{*,1}^{(i)} + c_4^{(i)} \cdot x_{*,3}^{(i+1)} + \dots &= 0, \\ x_{*,2}^{(i)} - x_{*,3}^{(i+1)} + \dots &= 0, \\ x_{E,1}^{(r_E)} + c_4^{(r_C+r_E)} \cdot x + \dots &= 0, \\ x_{E,2}^{(r_E)} - x + \dots &= 0, \end{aligned}$$

where \mathcal{A}_1 , \mathcal{A}_2 and \mathcal{A}_3 are affine polynomials. So, we can directly conclude from Equation (30) that

$$\hat{g}_3^{(i)} = \left(g_3^{(i)} \bmod (\mathcal{L}) \right) \in \mathbb{F}_q \left[x_{C,3}^{(2)}, \dots, x_{E,3}^{(r_C+r_E-1)}, x \right],$$

where $2 \leq i \leq r_C + r_E$, has leading monomial $x_{*,3}^{(i)2}$ and respectively x^2 for the last round.

Thus, we have constructed a polynomial system with pairwise coprime leading monomials, so by [CLO15, Chapter 2 §9 Theorem 3, Proposition 4] we have constructed a Gröbner basis. \square

Note that if we only keep the $r_E + r_C - 1$ quadratic polynomials of \mathcal{G} , then we still have a fully determined polynomial system in $r_E + r_C - 1$ variables as well as a Gröbner basis. Therefore, we call the quadratic polynomials of \mathcal{G} the downsized **Ciminion** polynomial system.

For the next corollary, recall that a LEX Gröbner basis $\mathcal{F} = \{f_1, \dots, f_n\} \subset K[x_1, \dots, x_n]$ is said to be in x_n -*shape position* if it is of the form

$$\begin{aligned} f_1 &= x_1 - \tilde{f}_1(x_n), \\ &\dots \\ f_{n-1} &= x_{n-1} - \tilde{f}_{n-1}(x_n), \\ f_n &= \tilde{f}_n(x_n). \end{aligned} \tag{32}$$

Note that the LEX Gröbner basis of a radical ideal can be brought into shape position for some ordering of the variables, see [KR00, Theore 3.7.25].

Corollary 3.2. *In the situation of Theorem 3.1, let $\mathcal{G}_{\text{Ciminion}}$ denote the Ciminion DRL Gröbner basis.*

- (1) $\dim_{\mathbb{F}_q}(\mathcal{F}_{\text{Ciminion}}) = 2^{r_C + r_E - 1}$.
- (2) Let $I \subset \overline{\mathbb{F}_q}[y_1, y_2, \mathbf{x}_C^{(1)}, \dots, \mathbf{x}_C^{(r_C-1)}, \mathbf{x}_E^{(1)}, \dots, \mathbf{x}_E^{(r_E)}, x][x_0]$ be a homogeneous ideal such that $\mathcal{Z}_+(I) \neq \emptyset$ and $\mathcal{G}^{\text{hom}} \subset I$. Then I is in generic coordinates.
- (3) $\text{sd}_{\text{DRL}}(\mathcal{F}_{\text{Ciminion}}) \leq r_C + r_E$.
- (4) The LEX Gröbner basis for Ciminion under $y_1 > y_2 > \mathbf{x}_C^{(1)} > \dots > \mathbf{x}_C^{(r_C-1)} > \mathbf{x}_E^{(1)} > \mathbf{x}_E^{(r_E)} > x$ is in x -shape position.

Proof. (1), (2) and (3) are consequences of the DRL Gröbner basis from Theorem 3.1 and application of Theorems 2.5 and 2.6. For the last claim we take a look at the shape of the DRL Gröbner basis

$$\begin{aligned} g_3^{(2)} &= \mathcal{Q}_2(x_{C,3}^{(2)}, \dots, x_{E,3}^{(2)}, x) - \mathcal{A}_2(x_{C,3}^{(2)}, \dots, x_{E,3}^{(r_E)}, x), \\ &\dots \\ g_3^{(i)} &= \mathcal{Q}_i(x_{*,3}^{(i)}, \dots, x_{E,3}^{(r_E)}, x) - \mathcal{A}_i(x_{*,3}^{(i-1)}, \dots, x_{E,3}^{(r_E)}, x), \\ &\dots \\ g_3^{(r_C+r_E)} &= \mathcal{Q}(x) - \mathcal{A}_{r_C+r_E}(x_{E,3}^{(r_E)}, x), \end{aligned}$$

where the \mathcal{Q}_i 's are quadratic polynomials which contain the monomial $x_{*,3}^{(i)2}$ and respectively x^2 for the last round, and the \mathcal{A}_i 's are affine polynomials that contain the monomial $x_{E,3}^{(i-1)}$ for all $i \geq 3$ and without any restrictions on \mathcal{A}_2 . Then by iterative substitution of $g_3^{(r_C+r_E)}$ into $g_3^{(r_C+r_E-1)}$, $g_3^{(r_C+r_E-1)}$ into $g_3^{(r_C+r_E-2)}$, etc. we produce a LEX Gröbner basis in x -shape position. \square

3.2 Bariant's Attack

Recently Bariant introduced an attack on Ciminion via univariate greatest common divisor computations [Bar23]. As in our polynomial model he introduced an auxiliary variable X for the truncated component. If one inverts p_E and p_C using (c_1, c_2, X) as output state one then obtains three polynomials, see [Bar23, Fig. 3],

$$\mathbb{N} = f_1(X), \quad K_1 = f_2(X), \quad K_2 = f_3(X). \tag{33}$$

Since the first polynomial is univariate in X one can compute its greatest common divisor with $X^q - X$ to solve for X and henceforth also solve for K_1 and K_2 .

We note that this attack can also be interpreted in terms of term order conversion of our DRL Gröbner basis to LEX, since the univariate polynomial $\aleph = f_1(X)$ is simply the univariate polynomial of the **Ciminion** LEX Gröbner basis in x -shape position. Moreover, the construction of the univariate LEX polynomial can be effectively expressed in the cost of univariate polynomial multiplication over finite fields [HvdH22] which is quasi-linear in the degree.

As countermeasure Bariant proposes to add a linear combination of K_1 and K_2 to each component after p_E . We note that this modification breaks our Gröbner basis from Theorem 3.1. As settlement, we propose to add a linear combination of K_1 and K_2 only to the non-linear parts of the round functions, e.g.

$$\mathcal{R}^{(l)} : \mathbb{F}_q^3 \times \mathbb{F}_q^2 \rightarrow \mathbb{F}_q^3, \quad \begin{pmatrix} x \\ y \\ z \end{pmatrix}, (K_1, K_2) \mapsto \begin{pmatrix} 0 & 0 & 1 \\ 1 & c_4^{(l)} & c_4^{(l)} \\ 0 & 0 & 1 \end{pmatrix} \begin{pmatrix} x \\ y \\ z + x \cdot y + \alpha \cdot K_1 + \beta \cdot K_2 \end{pmatrix} + \begin{pmatrix} c_1^{(l)} \\ c_2^{(l)} \\ c_3^{(l)} \end{pmatrix}, \quad (34)$$

where $\alpha, \beta \in \mathbb{F}_q$ and $\alpha \cdot \beta \neq 0$. This modification does not affect the proof of Theorem 3.1, hence we maintain the DRL Gröbner basis for the modified **Ciminion** polynomial system. However, this modification breaks the construction of the univariate LEX polynomial via univariate polynomial multiplication, because the DRL Gröbner basis polynomial for the r_C -th round will now also contain linear terms for the variables $x_{C,3}^{(2)}, \dots, x_{C,3}^{(r_C-2)}$ instead of only $x_{C,3}^{(r_C-1)}, x_{E,3}^{(1)}, \dots, x_{E,3}^{(r_E)}, x$. While the LEX Gröbner basis of the modified **Ciminion** might still be in x -shape position, we now can only construct it by running a FGLM algorithm.

Note if the modification of Equation (34) is performed in all rounds of p_E , then the Middle State-Output Relation polynomial system of Bariant et al. [BBLP22, §5] becomes underdetermined, so this attack connecting two outputs of two nonce samples would not be applicable anymore.

3.3 Implementation

We implemented **Ciminion** in the computer algebra systems **SageMath** [Sag24] and **OSCAR** [OSC24].³ In principle, the **SageMath** implementation can handle 128 bit prime numbers, though we do not recommend using primes of that size for experimental Gröbner basis computations, because **SageMath** uses Python implementations for primes of that size. The **OSCAR** computer algebra system offers an efficient F4 implementation that can handle primes of size $q < 2^{31}$, therefore we recommend to use **OSCAR** for experimental computations over small prime fields.

We implemented the Gröbner basis computation from Theorem 3.1 in **SageMath**. For practical parameters $p = 2^{127} + 45$, $r_C = 90$ and $r_E = 14$ a DRL Gröbner basis can be computed in negligible time.

3.3.1 Ciminion2

We also implemented a modified version of **Ciminion** to protect against Bariant's attack, see Equation (34), called **Ciminion2**, which adds $K_1 + K_2$ in the last round of p_C and every round of p_E to the non-linear component. I.e., the round function modifies to

$$\mathcal{R}^{(l)} : \begin{pmatrix} x \\ y \\ z \end{pmatrix}, \begin{pmatrix} K_1 \\ K_2 \end{pmatrix} \mapsto \begin{pmatrix} 0 & 0 & 1 \\ 1 & c_4^{(l)} & c_4^{(l)} \\ 0 & 1 & 1 \end{pmatrix} \begin{pmatrix} x \\ y \\ z + x \cdot y + K_1 + K_2 \end{pmatrix} + \begin{pmatrix} c_1^{(l)} \\ c_2^{(l)} \\ c_3^{(l)} \end{pmatrix}, \quad (35)$$

³<https://github.com/sca-research/Groebner-Basis-Cryptanalysis-of-Ciminion-and-Hydra.git>

where $r_C \leq l \leq r_C + r_E$. For `Ciminion2` a DRL Gröbner basis is also computed in negligible time in `SageMath` for practical parameters.

4 Analysis of Hydra

The Hydra heads are based on the Lai–Massey permutation. For the Gröbner basis analysis we recall that the Lai–Massey permutation

$$\mathcal{L} : \begin{pmatrix} x \\ y \end{pmatrix} \mapsto \begin{pmatrix} x + F(x - y) \\ y + F(x - y) \end{pmatrix} \quad (36)$$

is affine equivalent to the Feistel permutation

$$\mathcal{F} : \begin{pmatrix} x \\ y \end{pmatrix} \mapsto \begin{pmatrix} x \\ y + F(x) \end{pmatrix} \quad (37)$$

via the matrices $\mathbf{A}_1 = \begin{pmatrix} 1 & -1 \\ 0 & 1 \end{pmatrix}$ and $\mathbf{A}_2 = \begin{pmatrix} 1 & 1 \\ 0 & 1 \end{pmatrix}$, i.e. $\mathcal{L} = \mathbf{A}_2 \circ \mathcal{F} \circ \mathbf{A}_1$. Inspired by this equivalence one can reduce the Hydra polynomial system to only one non-linear equation per round, i.e. the Hydra polynomial system transforms to a Feistel-like polynomial system.

In [Ste24, §6.2] the iterated polynomial systems representing block ciphers based on generalized Feistel networks were analyzed. For these polynomial systems linear systems were derived, and in case the systems are of full rank the iterated polynomial systems are in generic coordinates, see [Ste24, Theorem 6.5].

Based on the aforementioned affine equivalence, we are going to replicate this strategy to construct such a linear system for Hydra.

4.1 Generic Coordinates for Hydra

Recall that the Hydra iterated polynomial system (Definition 2.2) consists of $16 \cdot r_{\mathcal{H}} + 8$ many polynomials in $16 \cdot r_{\mathcal{H}} + 4$ many variables. Let

$$\mathbf{A}_n = \begin{pmatrix} 1 & 0 & \dots & 0 & -1 \\ 0 & 1 & \dots & 0 & -1 \\ & & \ddots & & \\ 0 & 0 & \dots & 1 & -1 \\ 0 & 0 & \dots & 0 & 1 \end{pmatrix} \in \text{GL}_n(\mathbb{F}_q), \quad (38)$$

and let $\mathbf{B} = \text{diag}(\mathbf{A}_4, \mathbf{A}_4) \in \text{GL}_8(\mathbb{F}_q)$. Then the first seven components of $\mathbf{A}_8 \mathbf{M}_{\mathcal{J}}^{-1} \mathbf{f}_j^{(i)}$, where $1 \leq i \leq r_{\mathcal{H}}$ and $j \in \{1, 2\}$, are affine and the eighth component is quadratic. Moreover, the fourth and the eighth components of $\mathbf{B} \mathbf{M}_{\mathcal{R}}^{-1} \mathbf{f}_{\mathcal{R}}$ are quadratic while the other ones are affine. In particular, by extracting the $2 \cdot 7 \cdot r_{\mathcal{H}}$ affine components of the $\mathbf{A}_8 \mathbf{M}_{\mathcal{J}}^{-1} \mathbf{f}_j^{(i)}$'s we can eliminate the variables

$$y_1, \dots, y_4, z_1, \dots, z_3, x_{j,1}^{(i)}, \dots, x_{j,7}^{(i)}, \quad (39)$$

where $0 \leq i \leq r_{\mathcal{H}} - 1$ and $j \in \{1, 2\}$, in the quadratic equations. (This can be explicitly seen in the proof of Theorem 4.1.) Thus, after the elimination we reduce to $2 \cdot r_{\mathcal{H}} + 8$ polynomials, of whom 6 are also affine, in $2 \cdot r_{\mathcal{H}} + 4$ many variables. We call this polynomial system the downsized Hydra polynomial system.

Analog to the analysis of Feistel networks in [Ste24, §6.2], we now derive a linear system for Hydra with which we can verify whether the Hydra polynomial system is in generic coordinates.

Theorem 4.1. *Let \mathbb{F}_q be a finite field, let $\overline{\mathbb{F}_q}$ be its algebraic closure, let*

$$\mathcal{F}_{Hydra} = \left\{ \mathbf{f}_1^{(i)}, \mathbf{f}_{\mathcal{R}}, \mathbf{f}_2^{(i)} \right\}_{1 \leq i \leq r_{\mathcal{R}}} \subset P = \overline{\mathbb{F}_q}[\mathbf{y}, \mathbf{z}, \mathbf{x}_1^{(1)}, \dots, \mathbf{x}_1^{(r_{\mathcal{H}}-1)}, \mathbf{x}_2^{(0)}, \dots, \mathbf{x}_2^{(r_{\mathcal{H}}-1)}, \mathbf{k}]$$

be a Hydra polynomial system, and let

$$\mathcal{G}_{Hydra} = \left\{ \mathbf{A}_8 \mathbf{M}_{\mathcal{J}}^{-1} \mathbf{f}_1^{(i)}, \mathbf{B} \mathbf{M}_{\mathcal{R}}^{-1} \mathbf{f}_{\mathcal{R}}, \mathbf{A}_8 \mathbf{M}_{\mathcal{J}}^{-1} \mathbf{f}_2^{(i)} \right\}_{1 \leq i \leq r_{\mathcal{H}}}.$$

Then every homogeneous ideal $I \subset P[x_0]$ such that $\mathcal{Z}_+(I) \neq \emptyset$ and $\mathcal{G}_{Hydra}^{\text{hom}} \subset I$ is in generic coordinates if the following linear system has rank $16 \cdot r_{\mathcal{H}} + 4$

$$\begin{aligned} y_1 - z_4 + \left(\mathbf{M}_{\mathcal{J}}^{-1} (\mathbf{k}' - \mathbf{x}_1^{(1)}) \right)_1 + \left(\mathbf{M}_{\mathcal{J}}^{-1} (\mathbf{x}_1^{(1)} - \mathbf{k}') \right)_8 &= 0, \\ &\vdots \\ z_3 - z_4 + \left(\mathbf{M}_{\mathcal{J}}^{-1} (\mathbf{k}' - \mathbf{x}_1^{(1)}) \right)_7 + \left(\mathbf{M}_{\mathcal{J}}^{-1} (\mathbf{x}_1^{(1)} - \mathbf{k}') \right)_8 &= 0, \\ &\sum_{l=1}^4 y_l - z_l = 0, \\ x_{2,k}^{(0)} - x_{2,8}^{(0)} + \left(\mathbf{M}_{\mathcal{J}}^{-1} (\mathbf{k}' - \mathbf{x}_2^{(1)}) \right)_k + \left(\mathbf{M}_{\mathcal{J}}^{-1} (\mathbf{x}_2^{(1)} - \mathbf{k}') \right)_8 &= 0, \\ &\sum_{l=1}^8 (-1)^{\lfloor \frac{l-1}{4} \rfloor} \cdot x_{2,l}^{(0)} = 0, \\ x_{j,k}^{(i)} - x_{j,8}^{(i)} + \left(\mathbf{M}_{\mathcal{J}}^{-1} (\mathbf{k}' - \mathbf{x}_j^{(i+1)}) \right)_k + \left(\mathbf{M}_{\mathcal{J}}^{-1} (\mathbf{x}_j^{(i+1)} - \mathbf{k}') \right)_8 &= 0, \\ &\sum_{l=1}^8 (-1)^{\lfloor \frac{l-1}{4} \rfloor} \cdot x_{j,l}^{(i)} = 0, \\ x_{j,k}^{(r_{\mathcal{H}}-1)} - x_{j,8}^{(r_{\mathcal{H}}-1)} + \left(\mathbf{M}_{\mathcal{J}}^{-1} (\mathbf{k}' + (\mathbf{y}, \mathbf{z})^\top) \right)_k - \left(\mathbf{M}_{\mathcal{J}}^{-1} (\mathbf{k}' + (\mathbf{y}, \mathbf{z})^\top) \right)_8 &= 0, \\ &\sum_{l=1}^8 (-1)^{\lfloor \frac{l-1}{4} \rfloor} \cdot x_{j,l}^{(r_{\mathcal{H}}-1)} = 0, \\ x_{j,k}^{(r_{\mathcal{H}}-1)} - x_{j,8}^{(r_{\mathcal{H}}-1)} + \left(\mathbf{M}_{\mathcal{J}}^{-1} (\mathbf{k}' + \mathbf{x}_2^{(0)}) \right)_k - \left(\mathbf{M}_{\mathcal{J}}^{-1} (\mathbf{k}' + \mathbf{x}_2^{(0)}) \right)_8 &= 0, \\ &\sum_{l=1}^8 (-1)^{\lfloor \frac{l-1}{4} \rfloor} \cdot x_{j,l}^{(r_{\mathcal{H}}-1)} = 0, \\ y_1 - y_4 - \left(\mathbf{M}_{\mathcal{R}}^{-1} \mathbf{x}_2^{(0)} \right)_1 + \left(\mathbf{M}_{\mathcal{R}}^{-1} \mathbf{x}_2^{(0)} \right)_8 &= 0, \\ &\vdots \\ y_3 - y_4 - \left(\mathbf{M}_{\mathcal{R}}^{-1} \mathbf{x}_2^{(0)} \right)_3 + \left(\mathbf{M}_{\mathcal{R}}^{-1} \mathbf{x}_2^{(0)} \right)_8 &= 0, \\ z_1 - z_4 - \left(\mathbf{M}_{\mathcal{R}}^{-1} \mathbf{x}_2^{(0)} \right)_5 + \left(\mathbf{M}_{\mathcal{R}}^{-1} \mathbf{x}_2^{(0)} \right)_8 &= 0, \\ &\vdots \\ z_3 - z_4 - \left(\mathbf{M}_{\mathcal{R}}^{-1} \mathbf{x}_2^{(0)} \right)_7 + \left(\mathbf{M}_{\mathcal{R}}^{-1} \mathbf{x}_2^{(0)} \right)_8 &= 0, \end{aligned}$$

where $2 \leq i \leq r_{\mathcal{H}} - 1$, $j \in \{1, 2\}$ and $1 \leq k \leq 7$.

Proof. By [Ste24, Theorem 3.2] we have to show that

$$\sqrt{\mathcal{G}^{\text{top}}} = \left(\mathbf{y}, \mathbf{z}, \mathbf{x}_j^{(i)}, \dots, \mathbf{x}_1^{(r_{\mathcal{H}}-1)}, \mathbf{x}_2^{(0)}, \dots, \mathbf{x}_2^{(r_{\mathcal{H}}-1)}, \mathbf{k} \right)$$

To shorten some writing let

$$\begin{aligned} \mathbf{g}_j^{(i)} &= \left(\mathbf{A}_8 \mathbf{M}_{\mathcal{J}}^{-1} \mathbf{f}_j^{(i)} \right)^{\text{hom}} \pmod{x_0}, \\ \mathbf{g}_{\mathcal{R}} &= \left(\mathbf{B} \mathbf{M}_{\mathcal{R}}^{-1} \mathbf{f}_{\mathcal{R}} \right)^{\text{hom}} \pmod{x_0}. \end{aligned}$$

Then for $i = 1$ we have that

$$\begin{aligned} \mathbf{g}_1^{(1)} &= \left(\begin{array}{c} \left\{ y_k - z_4 + \left(\mathbf{M}_{\mathcal{J}}^{-1} (\mathbf{k}' - \mathbf{x}_1^{(1)}) \right)_k + \left(\mathbf{M}_{\mathcal{J}}^{-1} (\mathbf{x}_1^{(1)} - \mathbf{k}') \right)_8 \right\}_{1 \leq k \leq 7} \\ \left(\sum_{l=1}^4 y_l - z_l \right)^2 \end{array} \right), \\ \mathbf{g}_2^{(1)} &= \left(\begin{array}{c} \left\{ x_{2,k}^{(0)} - x_{2,8}^{(0)} + \left(\mathbf{M}_{\mathcal{J}}^{-1} (\mathbf{k}' - \mathbf{x}_2^{(1)}) \right)_k + \left(\mathbf{M}_{\mathcal{J}}^{-1} (\mathbf{x}_2^{(1)} - \mathbf{k}') \right)_8 \right\}_{1 \leq k \leq 7} \\ \left(\sum_{l=1}^8 (-1)^{\lfloor \frac{l-1}{4} \rfloor} \cdot x_{2,l}^{(0)} \right)^2 \end{array} \right). \end{aligned}$$

For $2 \leq i \leq r_{\mathcal{H}} - 1$ and $j \in \{1, 2\}$ we have that

$$\mathbf{g}_j^{(i)} = \left(\begin{array}{c} \left\{ x_{j,k}^{(i)} - x_{j,8}^{(i)} + \left(\mathbf{M}_{\mathcal{J}}^{-1} (\mathbf{k}' - \mathbf{x}_j^{(i+1)}) \right)_k + \left(\mathbf{M}_{\mathcal{J}}^{-1} (\mathbf{x}_j^{(i+1)} - \mathbf{k}') \right)_8 \right\}_{1 \leq k \leq 7} \\ \left(\sum_{l=1}^8 (-1)^{\lfloor \frac{l-1}{4} \rfloor} \cdot x_{j,l}^{(i)} \right)^2 \end{array} \right).$$

For $i = r_{\mathcal{H}}$ we have that

$$\begin{aligned} \mathbf{g}_1^{(r_{\mathcal{H}})} &= \left(\begin{array}{c} \left\{ x_{1,k}^{(r_{\mathcal{H}}-1)} - x_{1,8}^{(r_{\mathcal{H}}-1)} + \left(\mathbf{M}_{\mathcal{J}}^{-1} (\mathbf{k}' + (\mathbf{y}, \mathbf{z})^\top) \right)_k - \left(\mathbf{M}_{\mathcal{J}}^{-1} (\mathbf{k}' + (\mathbf{y}, \mathbf{z})^\top) \right)_8 \right\}_{1 \leq k \leq 7} \\ \left(\sum_{l=1}^8 (-1)^{\lfloor \frac{l-1}{4} \rfloor} \cdot x_{1,l}^{(r_{\mathcal{H}}-1)} \right)^2 \end{array} \right), \\ \mathbf{g}_2^{(r_{\mathcal{H}})} &= \left(\begin{array}{c} \left\{ x_{2,k}^{(r_{\mathcal{H}}-1)} - x_{2,8}^{(r_{\mathcal{H}}-1)} + \left(\mathbf{M}_{\mathcal{J}}^{-1} (\mathbf{k}' + \mathbf{x}_2^{(0)}) \right)_k - \left(\mathbf{M}_{\mathcal{J}}^{-1} (\mathbf{k}' + \mathbf{x}_2^{(0)}) \right)_8 \right\}_{1 \leq k \leq 7} \\ \left(\sum_{l=1}^8 (-1)^{\lfloor \frac{l-1}{4} \rfloor} \cdot x_{2,l}^{(r_{\mathcal{H}}-1)} \right)^2 \end{array} \right). \end{aligned}$$

Finally, for the rolling function we have that

$$\mathbf{B} \mathbf{g}_{\mathcal{R}} = \left(\begin{array}{c} \left\{ y_k - y_4 - \left(\mathbf{M}_{\mathcal{R}}^{-1} \mathbf{x}_2^{(0)} \right)_k + \left(\mathbf{M}_{\mathcal{R}}^{-1} \mathbf{x}_2^{(0)} \right)_4 \right\}_{1 \leq k \leq 3} \\ g(\mathbf{y}, \mathbf{z}) \\ \left\{ z_k - z_4 - \left(\mathbf{M}_{\mathcal{R}}^{-1} \mathbf{x}_2^{(0)} \right)_{4+k} + \left(\mathbf{M}_{\mathcal{R}}^{-1} \mathbf{x}_2^{(0)} \right)_8 \right\}_{1 \leq k \leq 3} \\ g(\mathbf{z}, \mathbf{y}) \end{array} \right).$$

Except for the rolling function, all quadratic functions are powers of affine equations, so by Theorem 2.6 (2) we can replace the powers by the affine equations. This yields the linear system from the assertion. \square

Naturally, this theorem can be extended to an arbitrary number of **Hydra** samples. It also follows by a simple contraposition that the downsized **Hydra** polynomial system in $2 \cdot r_{\mathcal{H}} + 4$ variables is in generic coordinates if the full polynomial system is in generic coordinates. Now it is straight-forward to compute the Macaulay bound (Theorem 2.5) for **Hydra**.

Corollary 4.2. *Let \mathbb{F}_q be a finite field, let $\overline{\mathbb{F}_q}$ be its algebraic closure, and let*

$$\tilde{\mathcal{F}}_{\text{Hydra}} \subset \overline{\mathbb{F}_q} \left[z_4, x_{1,8}^{(1)}, \dots, x_{1,8}^{(r_{\mathcal{H}}-1)}, x_{2,8}^{(0)}, \dots, x_{2,8}^{(r_{\mathcal{H}}-1)}, \mathbf{k} \right]$$

be the downsized **Hydra** polynomial system. If $\tilde{\mathcal{F}}_{\text{Hydra}}^{\text{hom}}$ is in generic coordinates, then

$$\text{sd}_{\text{DRL}} \left(\tilde{\mathcal{F}}_{\text{Hydra}} \right) \leq 2 \cdot r_{\mathcal{H}} + 3.$$

Remark 4.3. This bound can be further improved by utilizing the 6 affine equations from the rolling function. In case that these 6 equations are linearly independent of each other and all other affine equations, we can eliminate further 6 variables. Thus, the **Hydra** polynomial system reduces to $2 \cdot r_{\mathcal{H}} + 2$ quadratic polynomials in $2 \cdot r_{\mathcal{H}} - 2$ many variables. Then

$$\text{sd}_{\text{DRL}} \left(\tilde{\mathcal{F}}_{\text{Hydra}} \right) \leq 2 \cdot r_{\mathcal{H}}.$$

The reason why we did not incorporate this improvement in Theorem 2.5 is that elimination via the affine equations from the rolling function depends non-trivially on $\mathbf{M}_{\mathcal{R}}$ and $\mathbf{M}_{\mathcal{J}}$. Thus, a generic treatment is not possible.

4.2 Extracting a Zero-Dimensional DRL Gröbner Basis for **Hydra**

Under the assumption of Remark 4.3, we can extract a zero-dimensional Gröbner basis from the downsized **Hydra** polynomial system via a linear change of coordinates. Then, $2 \cdot r_{\mathcal{H}}$ quadratic polynomials stem from **Hydra** heads and the remaining two from the rolling function.

Recall that the quadratic terms in the heads are of the form

$$g_1^{(1)} = \left(\sum_{l=1}^4 y_l - z_l \right)^2, \quad g_2^{(1)} = \left(\sum_{l=1}^8 (-1)^{\lfloor \frac{l-1}{4} \rfloor} \cdot x_{2,l}^{(0)} \right)^2, \quad (40)$$

$$g_j^{(i)} = \left(\sum_{l=1}^8 (-1)^{\lfloor \frac{l-1}{4} \rfloor} \cdot x_{j,l}^{(i)} \right)^2, \quad 2 \leq i \leq r_{\mathcal{H}} - 1, j \in \{1, 2\} \quad (41)$$

$$g_1^{(r_{\mathcal{H}})} = \left(\sum_{l=1}^8 (-1)^{\lfloor \frac{l-1}{4} \rfloor} \cdot x_{1,l}^{(r_{\mathcal{H}}-1)} \right)^2, \quad g_2^{(r_{\mathcal{H}})} = \left(\sum_{l=1}^8 (-1)^{\lfloor \frac{l-1}{4} \rfloor} \cdot x_{2,l}^{(r_{\mathcal{H}}-1)} \right)^2, \quad (42)$$

i.e. they are the squares of linear combinations of the variables. Therefore, we collect these linear combinations in a matrix $\mathbf{M} \in \mathbb{F}_q^{2 \cdot r_{\mathcal{H}} \times (2 \cdot r_{\mathcal{H}} - 2)}$ analog to the linear system in Theorem 4.1 to verify generic coordinates for **Hydra**. If $\text{rank}(\mathbf{M}) = 2 \cdot r_{\mathcal{H}} - 2$, then we can perform a linear change of coordinates to new variables $\hat{x}_1, \dots, \hat{x}_{2 \cdot r_{\mathcal{H}} - 2}$. After the change of coordinates the **Hydra** polynomial system contains $2 \cdot r_{\mathcal{H}} - 2$ polynomials of the form

$$g_i = \hat{x}_i^2 + \sum_{j=1}^{2 \cdot r_{\mathcal{H}} - 2} \alpha_{i,j} \cdot \hat{x}_j + \alpha_{i,0}. \quad (43)$$

Trivially, $\mathcal{G}_{\text{Hydra}} = \{g_i\}_{1 \leq i \leq 2 \cdot r_{\mathcal{H}} - 2} \subset \mathbb{F}_q[\hat{x}_1, \dots, \hat{x}_{2 \cdot r_{\mathcal{H}} - 2}]$ forms a zero-dimensional DRL Gröbner basis, see [CLO15, Chapter 2 §9 Theorem 3, Proposition 4]. In particular, for the \mathbb{F}_q -vector space dimension of the quotient ring we then have that

$$\dim_{\mathbb{F}_q}(\mathcal{G}_{\text{Hydra}}) = 2^{2 \cdot r_{\mathcal{H}} - 2}. \quad (44)$$

We also note that after an auxiliary division by remainder computation, the additional four polynomials are of the form

$$h_j = \sum_{1 \leq k < l \leq 2 \cdot r_{\mathcal{H}} - 2} \alpha_{i,k,l} \cdot \hat{x}_k \cdot \hat{x}_l + \sum_{k=1}^{2 \cdot r_{\mathcal{H}} - 2} \beta_{i,k} \cdot \hat{x}_k + \beta_{i,0}. \quad (45)$$

4.3 Implementation

We have implemented **Hydra** and its iterated polynomial system in the computer algebra system **SageMath** [Sag24] and **OSCAR** [OSC24].⁴ In principle, the **SageMath** implementation can handle 128 bit prime numbers, though we do not recommend using primes of that size for experimental Gröbner basis computations, because **SageMath** uses Python implementations for primes of that size. The **OSCAR** computer algebra system offers an efficient F4 implementation that can handle primes of size $q < 2^{31}$, therefore we recommend to use **OSCAR** for experimental computations over small prime fields.

Moreover, we implemented the linear system from Theorem 4.1 in **SageMath** to verify whether a **Hydra** instance is in generic coordinates. We stress that our generic coordinates test can handle practical parameters like 128 bit prime numbers. Also, our verification function can handle an arbitrary number of **Hydra** samples.

In case a **Hydra** polynomial system is in generic coordinates, we implemented the change of coordinates from Section 4.2 for two samples to extract a zero-dimensional DRL Gröbner basis from the **Hydra** polynomial system.

4.3.1 A Concrete Instance

In [GØSW22, Appendix C] the **Hydra** designers propose concrete matrices over the prime field $q = 2^{127} + 45$

$$\mathbf{M}_{\mathcal{E}} = \text{circ}(3, 2, 1, 1), \quad (46)$$

$$\mathbf{M}_{\mathcal{I}} = \begin{pmatrix} 1 & 1 & 1 & 1 \\ 1 & 4 & 1 & 1 \\ 3 & 1 & 3 & 1 \\ 4 & 1 & 1 & 2 \end{pmatrix}, \quad (47)$$

$$\mathbf{M}_{\mathcal{J}} = \begin{pmatrix} 3 & 1 & 1 & 1 & 1 & 1 & 1 & 1 \\ 7 & 3 & 1 & 1 & 1 & 1 & 1 & 1 \\ 4 & 1 & 4 & 1 & 1 & 1 & 1 & 1 \\ 3 & 1 & 1 & 8 & 1 & 1 & 1 & 1 \\ 7 & 1 & 1 & 1 & 7 & 1 & 1 & 1 \\ 8 & 1 & 1 & 1 & 1 & 5 & 1 & 1 \\ 5 & 1 & 1 & 1 & 1 & 1 & 2 & 1 \\ 4 & 1 & 1 & 1 & 1 & 1 & 1 & 6 \end{pmatrix}. \quad (48)$$

For security level $\kappa = 128$ the designers suggest to use $r_{\mathcal{H}} = 39$, see [GØSW23, §5.5].

For this instance using our **SageMath** implementation we verified that the **Hydra** polynomial system is in generic coordinates for $m \in \{2, 3, 4, 5, 10\}$ many samples. For

⁴<https://github.com/sca-research/Groebner-Basis-Cryptanalysis-of-Ciminion-and-Hydra.git>

$m = 2$ we can compute a Hydra DRL Gröbner basis with the change of coordinates from Section 4.2. In particular, the polynomial system then consists of $2 \cdot r_{\mathcal{H}} + 2$ polynomials in $2 \cdot r_{\mathcal{H}} - 2$ variables, so we can use the slightly improved solving degree bound from Remark 4.3 to estimate the complexity of DRL Gröbner basis computations. On an Intel Core i7-10700 with 64 GB RAM verification of generic coordinates for $m = 2$ needs ≤ 10 s and for $m = 10$ it needs ≤ 4 min.

In addition, for $r_{\mathcal{H}} = 39$, to extract a Gröbner basis let $\mathbf{M} \in \mathbb{F}_q^{2 \cdot r_{\mathcal{H}} \times (2 \cdot r_{\mathcal{H}} - 2)}$ collect the linear combinations in the quadratic terms of the downsized Hydra polynomial system. Then, the rows with indices $3, \dots, 2 \cdot r_{\mathcal{H}}$ are linearly independent. We also note that we did not find a round number $r_{\mathcal{H}} \geq 2$ for which the Gröbner basis extraction fails.

5 Shaving-Off Bits with the Eigenvalue Method

Let $\mathcal{F} = \{f_1, \dots, f_n\} \subset \mathbb{F}_q[x_1, \dots, x_n]$ be such that $\text{LM}_{DRL}(f_i) = x_i^2$ for all i , then \mathcal{F} is a zero-dimensional Gröbner basis. Moreover, for `Ciminion` and `Hydra` we found Gröbner bases that satisfy this assumption. In Section 2.5 we already discussed that one can solve for the zero-locus of \mathcal{F} by computing the eigenvalues of the multiplication matrices while maintaining the complexity estimate of the probabilistic FGLM algorithm [FGHR14]. We will now discuss that we can slightly improve the complexity estimate by taking the *multiplicative structure* of $\mathbb{F}_q[x_1, \dots, x_n]/(\mathcal{F})$ into account.

Recall that a \mathbb{F}_q -vector space basis of $\mathbb{F}_q[x_1, \dots, x_n]/(\mathcal{F})$ is given by the monomials not contained in $\text{in}_{DRL}(\mathcal{F}) = (x_1^2, \dots, x_n^2)$. Let \mathcal{B}' be the monomials not contained in $(x_1^2, \dots, x_{n-1}^2) \subset \mathbb{F}_q[x_1, \dots, x_{n-1}]$, then we sort the quotient space basis as $\mathcal{B} = \{\mathcal{B}', x_n \cdot \mathcal{B}'\}$. The multiplication matrix for x_n is then of the form

$$\mathbf{M}_{x_n} = \begin{pmatrix} \mathcal{B}' & x_n \cdot \mathcal{B}' \\ \mathbf{0}_{2^{n-1} \times 2^{n-1}} & \mathbf{I}_{2^{n-1} \times 2^{n-1}} \\ \mathbf{A} & \mathbf{B} \end{pmatrix} \begin{matrix} x_n \cdot \mathcal{B}' \\ x_n^2 \cdot \mathcal{B}' \end{matrix}, \quad (49)$$

where $\mathbf{A}, \mathbf{B} \in \mathbb{F}_q^{2^{n-1} \times 2^{n-1}}$. By definition, the characteristic polynomial is given by the determinant

$$\chi_{x_n}(x) = \det(\mathbf{I}_{2^n \times 2^n} \cdot x - \mathbf{M}_{x_n}) = \det \begin{pmatrix} \mathbf{I}_{2^{n-1} \times 2^{n-1}} \cdot x & -\mathbf{I}_{2^{n-1} \times 2^{n-1}} \\ \mathbf{A} & \mathbf{I}_{2^{n-1} \times 2^{n-1}} \cdot x - \mathbf{B} \end{pmatrix}. \quad (50)$$

For the LU-decomposition from Equation (24), we lift the determinant computation from the polynomial ring $\mathbb{F}_q[x]$ to its fraction field $\mathbb{F}_q(x)$, i.e. we treat x as invertible. Then with Equation (25)

$$\chi_{x_n}(x) = \det \begin{pmatrix} \mathbf{I}_{2^{n-1} \times 2^{n-1}} \cdot x & -\mathbf{I}_{2^{n-1} \times 2^{n-1}} \\ -\mathbf{A} & \mathbf{I}_{2^{n-1} \times 2^{n-1}} \cdot x - \mathbf{B} \end{pmatrix} \quad (51)$$

$$= \det(\mathbf{I}_{2^{n-1} \times 2^{n-1}} \cdot x) \cdot \det(\mathbf{I}_{2^{n-1} \times 2^{n-1}} \cdot x - \mathbf{B} - \mathbf{A} \cdot x^{-1}) \quad (52)$$

$$= x^{2^{n-1}} \cdot \det(\mathbf{I}_{2^{n-1} \times 2^{n-1}} \cdot x - \mathbf{B} - \mathbf{A} \cdot x^{-1}) \quad (53)$$

$$= \det(\mathbf{I}_{2^{n-1} \times 2^{n-1}} \cdot x^2 - \mathbf{B} \cdot x - \mathbf{A}), \quad (54)$$

where the latter equality follows from the fact that the determinant is a homogeneous function. We note that a similar determinant trick has been applied in [BBL⁺24, §3.2] to improve characteristic polynomial computations for specially shaped Gröbner bases.

For the next variable x_{n-1} , we extract a \mathbb{F}_q -valued solution for x_n via the GCD method, substitute it into $\mathcal{F} \setminus \{f_n\}$, and repeat the trick for the multiplication matrix, see Equation (49), with one variable less.

Let $D(d, q)$ denote the complexity of the GCD with the field equation, see Equation (1). Provided that every characteristic polynomial has at most N roots in \mathbb{F}_q , then the complexity of the Eigenvalue method with standard determinant complexity is given by

$$\mathcal{O}\left(\sum_{i=1}^n N^{n-i} \cdot \left(2^{\omega \cdot i} + D(2^i, q)\right)\right) = \mathcal{O}\left(2^\omega \cdot \frac{2^{\omega \cdot n} - N^n}{2^\omega - N} + \sum_{i=1}^n N^{n-i} \cdot D(2^i, q)\right). \quad (55)$$

With the determinant trick from Equation (54) the complexity for the Eigenvalue Method then improves to

$$\mathcal{O}\left(\sum_{i=1}^n N^{n-i} \cdot \left(2^{\omega \cdot (i-1)} + D(2^i, q)\right)\right) = \mathcal{O}\left(\frac{2^{\omega \cdot n} - N^n}{2^\omega - N} + \sum_{i=1}^n N^{n-i} \cdot D(2^i, q)\right). \quad (56)$$

In addition, for $N = 1$, this implies by $\omega \geq 2$ that

$$\log_2\left(\frac{2^{\omega \cdot n} - 1}{2^\omega - 1}\right) \leq \omega \cdot n - \log_2(3). \quad (57)$$

I.e., we expect an improvement of at least $\log_2(3) \approx 1.5849$ compared to generic probabilistic term order conversion for an ideal in shape position.

By imposing more structure on \mathcal{F} we can refine Equation (56) even further. Suppose that every $f_i \in \mathcal{F}$ is of the form

$$f_i = x_i^2 + \mathcal{A}_i(x_1, \dots, x_n), \quad (58)$$

where \mathcal{A}_i is an affine polynomial. Assume we have found a solution for x_n , say $x_n = \alpha_n$, then we can rearrange

$$\beta_{n-1} \cdot x_{n-1} = \alpha_n^2 + \tilde{\mathcal{A}}_i(x_1, \dots, x_{n-2}, \alpha_n). \quad (59)$$

(If $\beta_{n-1} = 0$, then we simply rename the variables.) We can then further eliminate the variable x_{n-1} in the polynomial system $\mathcal{F} \setminus \{f_{n-1}, f_n\} \subset \mathbb{F}_q[x_1, \dots, x_n]$ by substituting the previous affine equation for x_{n-1} and $x_n = \alpha_n$. I.e., by finding one eigenvalue we can eliminate two variables. We also note that the Hydra DRL Gröbner basis (Section 4.2) satisfies the shape of Equation (58). Then, by iterating this variable elimination Equation (56) improves to

$$\mathcal{O}\left(\left\{\begin{array}{l} \sum_{i=1}^{\frac{n}{2}} N^{n-2 \cdot i} \cdot \left(2^{\omega \cdot (2 \cdot i-1)} + D(2^{2 \cdot i}, q)\right), \quad 2 \mid n, \\ \sum_{i=1}^{\frac{n-1}{2}} N^{n-1-2 \cdot i} \cdot \left(2^{\omega \cdot 2 \cdot i} + D(2^{2 \cdot i+1}, q)\right), \quad 2 \nmid n \end{array}\right.\right) \quad (60)$$

$$= \mathcal{O}\left(\left\{\begin{array}{l} 2^\omega \cdot \frac{2^{\omega \cdot n} - N^n}{2^{2 \cdot \omega} - N^2} + \sum_{i=1}^{\frac{n}{2}} N^{n-2 \cdot i} \cdot D(2^{2 \cdot i}, q), \quad 2 \mid n, \\ 2^{2 \cdot \omega} \cdot \frac{2^{\omega \cdot (n-1)} - N^n}{2^{2 \cdot \omega} - N^2} + \sum_{i=1}^{\frac{n-1}{2}} N^{n-1-2 \cdot i} \cdot D(2^{2 \cdot i+1}, q), \quad 2 \nmid n \end{array}\right.\right), \quad (61)$$

where we again assume that every characteristic polynomial has at most N roots in \mathbb{F}_q .

Again for $N = 1$, this implies that

$$\log_2\left(\left\{\begin{array}{l} 2^\omega \cdot \frac{2^{\omega \cdot n} - 1}{2^{2 \cdot \omega} - 1}, \quad 2 \mid n, \\ 2^{2 \cdot \omega} \cdot \frac{2^{\omega \cdot (n-1)} - 1}{2^{2 \cdot \omega} - 1}, \quad 2 \nmid n \end{array}\right.\right) \leq \omega(n+1) - \log_2(2^{2 \cdot \omega} - 1) \quad (62)$$

$$\approx \begin{cases} 2 \cdot n - 1.9069, & \omega = 2, \\ 3 \cdot n - 2.9773, & \omega = 3. \end{cases} \quad (63)$$

I.e., we expect an improvement of $\approx \omega$ compared to generic probabilistic term order conversion.

6 Boolean Macaulay Matrices

Let $\mathcal{F} \subset \mathbb{F}_2[x_1, \dots, x_n]$ be a polynomial system. If we are only interested in \mathbb{F}_2 -valued solutions, then it is sufficient to compute a Gröbner basis of the ideal $(\mathcal{F}, x_1^2 - x_1, \dots, x_n^2 - x_n)$. On the other hand, via the field equations $F = (x_1^2 - x_1, \dots, x_n^2 - x_n)$ we can reduce any monomial in the Macaulay matrix to a square-free monomial. Effectively, this reduces the full Macaulay matrix to a square-free submatrix, the so-called *Boolean Macaulay matrix*. Gaussian elimination for Boolean DRL Macaulay matrices over \mathbb{F}_2 was analyzed in [BFSS13] by Bardet et al.

Interestingly, for **Ciminion & Hydra** we found zero-dimensional DRL Gröbner bases with leading monomials x_i^2 . Hence, for Gröbner basis computations we can use these bases to reduce the Macaulay matrix to a “Boolean” one over an arbitrary finite field \mathbb{F}_q . This motivates the following definitions.

Definition 6.1. *Let K be a field, let $\mathcal{F} \subset P = K[x_1, \dots, x_n]$, and let $>$ be a degree compatible term order on P . \mathcal{F} is said to be a K -Boolean polynomial system if*

- (i) *for every $1 \leq i \leq n$ there exists $f \in \mathcal{F}$ such that $\text{LM}_{>}(f) = x_i^2$, and*
- (ii) *\mathcal{F} is a $>$ -Gröbner basis.*

Definition 6.2 (cf. [BFSS13, Definition 1]). *Let K be a field, let $\mathcal{F}_{\text{Bool}}, \mathcal{F} \subset P = K[x_1, \dots, x_n]$ be polynomial systems, and let $>$ be a degree compatible term order on P . Assume that $\mathcal{F}_{\text{Bool}}$ is K -Boolean with respect to $>$. For the (inhomogeneous) K -Boolean Macaulay matrix $M_{\leq d}^{\text{Bool}}$:*

- *Columns are indexed by square-free monomials $s \in P \setminus \text{in}_{>}(\mathcal{F}_{\text{Bool}})$ with $\deg(m) \leq d$ sorted via $>$.*
- *Rows are index by polynomials $t \cdot f$ where $t \in P \setminus \text{in}_{>}(\mathcal{F}_{\text{Bool}})$ is a square-free monomial and $f \in \mathcal{F}$ such that $\deg(t \cdot f) \leq d$.*
- *In the row $t \cdot f$ one writes the coefficients of the remainder $r_{t \cdot f} = t \cdot f \bmod (\mathcal{F}_{\text{Bool}})$ with respect to $>$.*

Note that any monomial $t \in P$ can be reduced to a square-free monomial $\hat{t} \equiv t \bmod (\mathcal{F}_{\text{Bool}})$ with $\deg(\hat{t}) \leq \deg(t)$ due to degree compatibility of $>$. Since remainders with respect to a Gröbner basis are unique, see [CLO15, Chapter 2 §6 Proposition 1], for the remainder of $t \cdot f$ it does not matter whether we reduce t first and then $\hat{t} \cdot f$ or $t \cdot f$ at once. So it is indeed sufficient to consider only products with square-free monomials.

Obviously, the remainder $r_{t \cdot f} = t \cdot f \bmod (\mathcal{F}_{\text{Bool}})$ is polynomial consisting of square-free terms. Moreover, by elementary properties of multivariate division by remainder with respect to a degree compatible term order, see [CLO15, Chapter 2 §3 Theorem 3], we have that

$$t \cdot f = \sum_{i=1}^m g_i \cdot f_i^{\text{Bool}} + r_{t \cdot f}, \quad (64)$$

where $\deg(g_i \cdot f_i^{\text{Bool}}), \deg(r_{t \cdot f}) \leq \deg(t \cdot f)$. I.e., the K -Boolean Macaulay matrix can be constructed via row operations from the Macaulay matrix $M_{\leq d}$ of $\mathcal{F} \cup \mathcal{F}_{\text{Bool}}$. Alternatively,

we can obtain the K -Boolean Macaulay matrix by pivoting non-square-free monomials in $M_{\leq d}$ via rows coming from $\mathcal{F}_{\text{Bool}}$, and then performing an auxiliary Gaussian elimination step that stops after all redundant pivots coming from $\mathcal{F}_{\text{Bool}}$ have been eliminated.

Let $M_{\leq d}$ be a Macaulay matrix, we denote with $\text{rowsp}(M_{\leq d})$ the row space basis, i.e. the polynomial system obtained via Gaussian elimination on $M_{\leq d}$. Analog, we use this notation for Boolean Macaulay matrices.

Definition 6.3 (Boolean Solving Degree). *Let K be a field, let $\mathcal{F}_{\text{Bool}}, \mathcal{F} \subset P = K[x_1, \dots, x_n]$ be polynomial systems, and let $>$ be a degree compatible term order on P . Assume that $\mathcal{F}_{\text{Bool}}$ is K -Boolean with respect to $>$. The Boolean solving degree of $\mathcal{F} \cup \mathcal{F}_{\text{Bool}}$ is the least degree d such that $\text{rowsp}(M_{\leq d}^{\text{Bool}}) \cup \mathcal{F}_{\text{Bool}}$ contains a Gröbner basis with respect to $>$. We denote it by $\text{sd}_{>}^{\text{Bool}}(\mathcal{F} \cup \mathcal{F}_{\text{Bool}})$.*

Note that $\text{rowsp}(M_{\leq d}^{\text{Bool}})$ might not contain zero-dimensional Gröbner basis of the full system. A trivial example is $\mathcal{F} = \{x_1^2, x_1 \cdot x_2, x_2^2\}$. Therefore, to extract the Gröbner basis from $\text{rowsp}(M_{\leq d}^{\text{Bool}}) \cup \mathcal{F}_{\text{Bool}}$ we set up the ideal of $>$ -leading terms and then compute its minimal generating set. With the minimal generating set we can then filter the Gröbner basis. (It is also obvious that all non-square-free monomials are generated by the leading terms of $\mathcal{F}_{\text{Bool}}$, hence it is indeed sufficient to just consider $\text{rowsp}(M_{\leq d}^{\text{Bool}}) \cup \mathcal{F}_{\text{Bool}}$.)

The next theorem follows straight-forward from $M_{\leq d}^{\text{Bool}} \subset M_{\leq d}$ (as K -vector spaces).

Theorem 6.4. *Let K be a field, let $\mathcal{F}_{\text{Bool}}, \mathcal{F} \subset P = K[x_1, \dots, x_n]$ be polynomial systems, and let $>$ be a degree compatible term order on P . Assume that $\mathcal{F}_{\text{Bool}}$ is K -Boolean with respect to $>$. Then*

$$(1) \text{sd}_{>}^{\text{Bool}}(\mathcal{F} \cup \mathcal{F}_{\text{Bool}}) \leq \text{sd}_{>}(\mathcal{F} \cup \mathcal{F}_{\text{Bool}}).$$

$$(2) \text{ If } d = \text{sd}_{>}^{\text{Bool}}(\mathcal{F} \cup \mathcal{F}_{\text{Bool}}) < n, \text{ then Gaussian elimination on } M_{\leq d}^{\text{Bool}} \text{ requires}$$

$$\mathcal{O}\left(|\mathcal{F}| \cdot \left(\sum_{i=1}^d \binom{n}{i}\right)^\omega\right)$$

field operations.

$$(3) \text{ If } d = \text{sd}_{>}(\mathcal{F} \cup \mathcal{F}_{\text{Bool}}) \geq n, \text{ then Gaussian elimination on } M_{\leq d}^{\text{Bool}} \text{ requires at most}$$

$$\mathcal{O}(|\mathcal{F}| \cdot 2^{\omega \cdot n})$$

field operations to produce a $>$ -Gröbner basis.

Proof. For (1), we pivot non-square-free monomials via polynomials from $\mathcal{F}_{\text{Bool}}$, then we perform the auxiliary Gaussian elimination step that produces $M_{\leq d}^{\text{Bool}}$ as submatrix, and finally we perform Gaussian elimination on $M_{\leq d}^{\text{Bool}}$. Since Gaussian elimination does not depend on the order of reductions $\text{rowsp}(M_{\leq d}^{\text{Bool}}) \cup \mathcal{F}_{\text{Bool}}$ has to contain the $>$ -Gröbner basis.

For (2), trivially in degree i there exist $\binom{n}{i}$ square-free monomials, and every $f \in \mathcal{F}$ can contribute to at most $\binom{n}{i}$ rows. I.e., the number of columns is bounded by $D = \sum_{i=1}^d \binom{n}{i}$, and the number of rows by $|\mathcal{F}| \cdot D$. The complexity of Gaussian elimination then follows from [Sto00, §2.2].

For (3), let $s \in P$ be a non-square-free monomial with $\deg(s) > n$, then $\hat{s} \equiv s \pmod{(\mathcal{F}_{\text{Bool}})}$ where $\hat{s} \in P$ is square-free, in particular $\deg(\hat{s}) \leq n$. Therefore, it suffices to perform Gaussian elimination on the full K -Boolean Macaulay matrix. Moreover, it is well known that $\sum_{i=0}^n \binom{n}{i} = 2^n$. \square

Remark 6.5. This theorem can be refined by replacing the binomial coefficient $\binom{n}{i}$ by the number of monomials in $P \setminus \text{in}_{>}(\mathcal{F}_{\text{Bool}})$ of degree i .

So far our analysis does not differ from the one over \mathbb{F}_2 , however the binary field has a special feature. Division by remainder with respect to $(x_1^2 - x_1, \dots, x_n^2 - x_n)$ is “for free”, i.e. its complexity is negligible compared to Gaussian elimination. For general K -Boolean polynomial systems this is not necessarily the case. Luckily, the complexity of general division by remainder with respect to quadratic K -Boolean polynomial systems follows as corollary to [Ten19, Proposition 3.10].

Corollary 6.6. *Let K be a field, let $\mathcal{F}_{\text{Bool}} \subset P = K[x_1, \dots, x_n]$ be a quadratic polynomial system, let $f \in P$ be a polynomial, and let $>$ be a degree compatible term order on P . Assume that $\mathcal{F}_{\text{Bool}}$ is K -Boolean with respect to $>$. Then computation of $r_f = f \bmod (\mathcal{F}_{\text{Bool}})$ with respect to $>$ requires*

$$\begin{aligned} & \mathcal{O} \left(\frac{n^2 + 3 \cdot n + 2}{2} \cdot \sum_{i=0}^{\deg(f)} \binom{n+i-1}{i} \right) \\ & \in \mathcal{O} \left(\frac{n^2 + 3 \cdot n + 2}{2} \cdot \deg(f) \cdot \binom{n + \deg(f) - 1}{\deg(f)} \right) \end{aligned}$$

field operations.

Proof. There exist $\sum_{i=0}^{\deg(f)} \binom{n+i-1}{i}$ monomials of degree $\leq \deg(f)$ and $\binom{n+1}{2} + \binom{n}{1} + 1$ monomials of degree ≤ 2 . Now the claim follows from [Ten19, Proposition 3.10]. \square

Thus, the complexity of constructing the K -Boolean Macaulay matrix $M_{\leq d}^{\text{Bool}}$ with respect to quadratic K -Boolean system $\mathcal{F}_{\text{Bool}}$ is bounded by

$$\mathcal{O} \left(|\mathcal{F}| \cdot \frac{n^2 + 3 \cdot n + 2}{2} \cdot \left(\sum_{i=0}^d \binom{n+i-1}{i} \right) \cdot \left(\sum_{i=0}^d \binom{n}{i} \right) \right). \quad (65)$$

Moreover, we have the inequality

$$\underbrace{\left(\sum_{i=0}^d \binom{n}{i} \right)^2}_{\text{Gaussian elimination on } M_{\leq d}^{\text{Bool}}} \leq \underbrace{\left(\sum_{i=0}^d \binom{n+i-1}{i} \right) \cdot \left(\sum_{i=0}^d \binom{n}{i} \right)}_{\text{Construction of } M_{\leq d}^{\text{Bool}}} \leq \underbrace{\left(\sum_{i=0}^d \binom{n+i-1}{i} \right)^2}_{\text{Gaussian elimination on } M_{\leq d}}. \quad (66)$$

I.e. for $\omega = 2$, if we ignore implied constants and prefactors, then we expect that construction of the K -Boolean Macaulay matrix dominates the Gröbner basis computation for general quadratic K -Boolean polynomial systems.

Of course, the K -Boolean Macaulay matrix generalizes to more advanced linear algebra-based Gröbner basis algorithms. Current state-of-the-art are Faugère’s F4 [Fau99] and Matrix-F5 [Fau02] algorithms. These algorithms perform Gaussian elimination on the Macaulay matrix $M_{\leq d}$ for increasing values of d . Moreover, F4 and F5 avoid redundant rows via efficient selection criteria. We illustrate a simplified variant of F4. Let $\mathcal{F} \subset P = K[x_1, \dots, x_n]$ be a polynomial system, let $>$ be a term order, and let $M_{\leq d}$ be the Macaulay matrix for \mathcal{F} in degree d . Then, we perform Gaussian elimination on $M_{\leq d}$ which yields the row space basis \mathcal{G}_1 , now we set up a new Macaulay matrix $M_{\leq d}$ for \mathcal{G}_1 and again compute the row space basis \mathcal{G}_2 via Gaussian elimination. We iterate this procedure until the row space basis becomes stationary, i.e. $\mathcal{G}_i = \mathcal{G}_{i+1}$, then we verify whether \mathcal{G}_i is already a $>$ -Gröbner basis. If not then we pass to degree $d+1$ and repeat the procedure. Obviously, if the input system contains a K -Boolean polynomial system, then we can replace every full Macaulay matrix by its K -Boolean submatrix.

7 Cryptanalysis of Ciminion & Hydra

In this section we discuss how our results from the previous sections can be applied to cryptanalysis of Ciminion and Hydra.

7.1 Ciminion

For Gröbner basis cryptanalysis of Ciminion [DGGK21, § 4.4] the designers considered a weaker scheme where the keys are added after the permutations p_E instead of before the rolling functions, see [DGGK21, Fig. 7]. The designer claim that the weaker scheme is simpler to analyze than Ciminion. We reject this claim for the iterated Ciminion polynomial system, after all we have computed a DRL Gröbner basis for Ciminion with rather simple affine variable eliminations, see Theorem 3.1.

The designers assumed that weakened Ciminion polynomial systems are regular, moreover for regular systems it is well-known that the degree of regularity is equal to the Macaulay bound. Then, the DRL Gröbner basis complexity is bounded by [BFS04, Theorem 7]

$$\mathcal{O}\left(m \cdot d_{\text{reg}} \cdot \binom{n + d_{\text{reg}}}{d_{\text{reg}}}\right)^\omega. \quad (67)$$

For Ciminion cryptanalysis, it is then assumed that the DRL Gröbner basis computation is the most costly part in an attack. The Ciminion designers did not provide a dedicated analysis for the iterated polynomial model from Definition 2.1. They mostly analyze polynomial models where p_E and p_C or respectively $p_E \circ p_C$ are modeled without intermediate variables, i.e. they used a single polynomial vector for these permutations. The designers further claim that polynomial models with many intermediate variables do not improve upon the few variables but high degree polynomial models.

On the other hand, let $I, J \subset P$ be zero-dimensional ideals, then elementary we have that

$$I \subset J \quad \Rightarrow \quad \mathcal{Z}(J) \subset \mathcal{Z}(I), \quad (68)$$

and by the isomorphism theorem for rings

$$I \subset J \quad \Rightarrow \quad (P/I)/(J/I) \cong P/J. \quad (69)$$

In particular, the latter isomorphism also induces a surjection of finite dimensional K -vector spaces $P/I \twoheadrightarrow P/J$ which implies that $\dim_K(I) \geq \dim_K(J)$. In cryptographic terms this means that if \succ -Gröbner bases for I and J are known, then solving for the zero locus of I is at least as hard as solving for the zero locus of J if one uses only generic algorithms.

Back to Ciminion, the designers proposed to study the model in two variables for the keys for the full function, we call this model the fully substituted model. Trivially, we have that

$$(\text{fully substituted Ciminion model}) \subset (\text{iterated Ciminion model}). \quad (70)$$

Since we have a DRL Gröbner basis for the iterated model at hand, we reject the claim by the Ciminion designers that introducing intermediate state variables does not improve upon the fully substituted model. So, the only non-trivial step in a fully determined Ciminion polynomial system is the construction of a univariate polynomial.

As outlined in Corollary 3.2 and Section 3.2, the univariate LEX polynomial can be constructed by iterated substitution of a univariate polynomial into a quadratic polynomial. By [HvdH22] the complexity of univariate polynomial multiplication over a finite field is

$$\mathcal{O}\left(d \cdot \log(q) \cdot \log(d \cdot \log(q))\right), \quad (71)$$

where d is the maximum of the degrees of the polynomials. Then, the complexity of constructing the univariate LEX polynomial of **Ciminion** is bounded by

$$\mathcal{O}\left(2^{r_C+r_E-2} \cdot \log(q) \cdot \log\left(2^{r_C+r_E-2} \cdot \log(q)\right)\right). \quad (72)$$

In Table 3 we present the complexity of term order conversion via fast polynomial multiplication and the GCD with the field equation (Equation (1)) for **Ciminion**. Since the complexities of polynomial multiplication and the GCD are quasi-linear in the degree, one requires more than 110 rounds for standard **Ciminion** to achieve 128 bits of security.

Recall that we proposed a slightly modified variant **Ciminion2** (Section 3.3.1) with a key addition to the non-linear component in the last rounds of p_C every round of p_E . As discussed in Section 3.2, this modification breaks the construction of the univariate LEX polynomial via fast polynomial multiplication. For **Ciminion2** we therefore either have to do term order conversion to LEX or use the Eigenvalue method. For term order conversion via the probabilistic FGLM algorithm [FGHR14], since we cannot prove x -shape position we have to compute the LEX Gröbner basis for the radical ideal which has complexity

$$\tilde{\mathcal{O}}\left((r_C + r_E - 1) \cdot 2^{\omega \cdot (r_C + r_E - 1)}\right).$$

On the other hand, for **Ciminion2** it suffices to solve for the key variables via the Eigenvalue method. Since the **Ciminion2** DRL Gröbner basis satisfies the assumption of Section 5, the complexity of characteristic polynomial construction is

$$\mathcal{O}\left(2 \cdot 2^{\omega \cdot (r_C + r_E - 2)}\right). \quad (73)$$

In Table 3 we present the complexity of the Eigenvalue Method and the GCD with the field equation for **Ciminion2**. Since the Eigenvalue Method adds a factor ω (in logarithmic terms), more than 66 rounds for **Ciminion2** already achieve 128 bits of security.

If we add additional polynomials to the **Ciminion** or **Ciminion2** polynomial systems, then we can recompute the DRL Gröbner bases. It is clear from the Macaulay bound (Theorem 2.5) that a polynomial $f \in P$ with $\deg(f) \geq 2$ can only increase the Macaulay bound. On the other hand, if $\deg(f) = 1$, then we can eliminate one variable for free. Note that this does not affect the property of being in generic coordinates, but we would have to recompute the **Ciminion** Macaulay bound (Corollary 3.2). For the former case, we use

$$\mathcal{O}\left(\binom{2 \cdot (r_C + r_E - 1)}{r_C + r_E}\right)^\omega \quad (74)$$

as baseline for the complexity of DRL Gröbner basis computations. Based on our proven DRL complexity estimate, more than 36 rounds for **Ciminion** and **Ciminion2** polynomial systems achieve 128 bits of security.

Lastly, in Table 3 we provide an additional column to compare our estimations to the rational of the **Ciminion** designers. In [DGGK21, §4.4] it is proposed to model the **Ciminion** function via two polynomials in two variables, i.e. the fully substituted model, of degree $2^{r_C+r_E-1}$. Under the assumption that these polynomials are regular we can then use the binomial term in Equation (67) as baseline for DRL Gröbner basis computations

$$\mathcal{O}\left(\binom{2 + 2 \cdot (2^{r_C+r_E-1} - 1) + 1 - 1}{2 \cdot (2^{r_C+r_E-1} - 1) + 1}\right)^\omega = \mathcal{O}\left(2^{\omega \cdot (r_C+r_E)}\right), \quad (75)$$

For completeness, this complexity should not be compared to Equation (74). Since our DRL Gröbner basis complexity assumes that we have a **Ciminion** DRL Gröbner basis at hand plus some additional information that can be modeled via a non-linear polynomial. The

complexity of Equation (75) quantifies the complexity of finding a DRL Gröbner basis in the first place without any additional information. Now ignorance of the iterated polynomial model in [DGGK21] becomes even more damaging. After all, we have constructed an iterated DRL Gröbner basis in $\mathcal{O}(r_C + r_E)$ while for the fully substituted model we obtain an exponential complexity estimate for finding the DRL basis. Moreover, the strategies for direct polynomial system solving outperform the complexity of finding the DRL basis for the fully substituted model.

Table 3: Complexity estimations for various Gröbner basis attacks on **Ciminion** and **Ciminion2** with $q = 2^{127} + 45$ and $\omega = 2$.

		Complexity (bits)			
r_C	r_E	Fast Polynomial Multiplication	Eigenvalue Method	DRL Computation Iterated Model	DRL Computation Fully Substituted Model [DGGK21, §4.4]
30	6	49	68	134	72
60	6	80	128	253	132
90	6	111	188	372	192
90	14	119	204	404	208
90	23	128	222	440	226

Also, recall that $r_C \in \left\{ s + 6, \left\lceil \frac{2 \cdot (s+6)}{3} \right\rceil \right\}$, where s is the security level, for two **Ciminion** instantiations, see Table 2. In particular, for **Ciminion2** this already implies that for the quotient space dimension $\dim_{\mathbb{F}_q}(\mathcal{F}_{\text{Ciminion}}) \geq 2^{\frac{s}{2}}$. Therefore, round numbers based on Table 2 should be sufficient to achieve the security level in Gröbner basis attacks via the iterated polynomial system, provided of course a fix against Bariant’s attack [Bar23] is implemented.

7.2 Hydra

For Gröbner basis cryptanalysis of **Hydra** the designers considered the downsized iterated **Hydra** polynomial system, see [GØSW23, §7.4] and [GØSW22, Appendix I.2]. The designers assumed that the downsized system of $2 \cdot r_{\mathcal{H}} + 2$ equations in $2 \cdot r_{\mathcal{H}} - 2$ variables is semi-regular [Frø85, Par10]. Under the semi-regularity assumption one can extract the degree of regularity ([BFS04, Definition 4]) d_{reg} of the **Hydra** polynomial system from the Hilbert series [KR05, Chapter 5] which then yields the complexity estimate ([BFS04, Theorem 7])

$$\mathcal{O} \left((2 \cdot r_{\mathcal{H}} + 2) \cdot d_{\text{reg}} \cdot \binom{2 \cdot r_{\mathcal{H}} - 2 + d_{\text{reg}}}{d_{\text{reg}}} \right) \quad (76)$$

for DRL Gröbner basis computations. For $r_{\mathcal{H}}^* = 29$ the designers estimate $D_{\text{reg}} = 23$, with $\omega = 2$ this yields a complexity estimate of $\approx 2^{130.8}$ bits. Moreover, it is claimed that $r_{\mathcal{H}} = r_{\mathcal{H}}^* + 2 = 31$ rounds are sufficient to provide 128 bits of security against Gröbner basis attacks.

7.2.1 Term Order Conversion & Eigenvalue Method Complexity Estimate

In Section 4.2 we have outlined how one can extract a zero-dimensional DRL Gröbner basis from the **Hydra** polynomial system via a linear change of coordinates. We can directly use this Gröbner basis to perform term order conversion to LEX, or apply the dedicated Eigenvalue Method from Section 5 combined with \mathbb{F}_q -valued root extraction via the GCD. Since we could not prove that a LEX **Hydra** Gröbner basis is in shape position, we have to

use the complexity for the probabilistic FGLM [FGHR14] of radical ideals which becomes

$$\tilde{\mathcal{O}}\left((r_{\mathcal{H}} - 1) \cdot 2^{\omega \cdot 2 \cdot (r_{\mathcal{H}} - 1) + 1}\right). \quad (77)$$

For the Eigenvalue Method, the Hydra DRL Gröbner basis satisfies the assumptions of Section 5, and in addition it satisfies the shape condition of Equation (58). Therefore, we can use the complexity estimate from Equation (61). Since we do not know the number of \mathbb{F}_q -valued eigenvalues for the Hydra multiplication matrices we opt for a better safe than sorry approach. We assume that the first eigenvalue that an adversary recovers for each variable leads to the true key, i.e. we assume $N = 1$. Then, the Eigenvalue Method complexity becomes

$$\mathcal{O}\left(2^{\omega} \cdot \frac{2^{\omega \cdot (2 \cdot r_{\mathcal{H}} - 2)} - 1}{2^{2 \cdot \omega} - 1} + \sum_{i=1}^{r_{\mathcal{H}} - 1} D(2^{2^i}, q)\right), \quad (78)$$

where $D(2^i, q)$ again denotes the complexity of the GCD with the field equation (Equation (1)).

In Table 4 we have computed the complexities for term order conversion and efficient \mathbb{F}_q -valued root extraction via the GCD. From the formulae, we can directly see that for $\omega = 2$ and $r_{\mathcal{H}} \geq 34$ the complexities will always exceed 128 bits. On the other hand for $r_{\mathcal{H}}^* = 29$ term order conversion requires only 118 bits, and for $r_{\mathcal{H}} = r_{\mathcal{H}}^* + 2 = 31$ it requires 126 bits. This invalidates the claim by the Hydra designers that 31 rounds are sufficient to protect against Gröbner basis attacks. Moreover, term order conversion always outperforms DRL Gröbner basis computation under the semi-regularity assumption. Lastly, for the round numbers in Table 4 the Eigenvalue Method shaves-off at least 6 additional bits compared to term order conversion.

Table 4: Complexity estimate of the Eigenvalue Method and term order conversion to LEX with efficient \mathbb{F}_q -valued root extraction for Hydra with $q = 2^{127} + 45$ and $\omega = 2$.

	Complexity (Bits)		
$r_{\mathcal{H}}$	Eigenvalue Method	Term Order Conversion	Semi-Regular Estimate [GØSW23]
20	75	82	89
29	111	118	131
31	119	126	142
33	127	135	153
34	131	139	159
39	151	159	183

7.2.2 Proven DRL Complexity Estimate

Via Theorem 4.1 and our SageMath implementation (Section 4.3) we obtain the proven DRL solving degree estimate for the Hydra polynomial instance from Section 4.3.1

$$\text{sd}_{DRL}(\mathcal{F}_{\text{Hydra}}) \leq 2 \cdot r_{\mathcal{H}}. \quad (79)$$

Since the Hydra polynomial system contains a zero-dimensional DRL Gröbner basis after a linear change of coordinates (Section 4.2), we can reduce Gaussian elimination on the full Macaulay matrix to Gaussian elimination on the \mathbb{F}_q -Boolean Macaulay matrix. With Theorem 6.4 and Equation (65) the complexity of constructing the \mathbb{F}_q -Boolean Macaulay

matrix and Gaussian elimination for Hydra becomes

$$\mathcal{O} \left((8 \cdot r_{\mathcal{H}}^2 - 4 \cdot r_{\mathcal{H}}) \cdot \left(\sum_{i=0}^{2 \cdot r_{\mathcal{H}} - 2} \binom{2 \cdot r_{\mathcal{H}} + i - 3}{i} \cdot \binom{2 \cdot r_{\mathcal{H}} - 2}{i} \right) + 2^{\omega \cdot 2 \cdot (r_{\mathcal{H}} - 1) + 2} \right). \quad (80)$$

In Table 5 we evaluate our complexity bound.

Table 5: DRL Gröbner basis complexity estimate for Hydra via Equation (80) with $\omega = 2$.

$r_{\mathcal{H}}$	Complexity (Bits)	
	Proven Estimate	Semi-Regular Estimate [GØSW23]
20	105	89
29	151	131
31	161	142
33	172	153
34	177	159
39	203	183

Therefore, we have derived a computer aided proof for the complexity of Gröbner basis attacks on Hydra without resorting to unproven assumptions like semi-regularity. Our proven complexity estimate is significantly larger than the hypothesized one for Hydra, since the degree of regularity estimate is always less than the Macaulay bound.

7.2.3 Semi-Regular Complexity Estimate for the Boolean Macaulay Matrices

As already mentioned, in the Hydra cryptanalysis it is assumed that the polynomial system of $2 \cdot r_{\mathcal{H}} + 2$ equations in $2 \cdot r_{\mathcal{H}} - 2$ variables is semi-regular. If we assume that the substituted Hydra polynomial system that contains the DRL Gröbner basis (Section 4.2) is also semi-regular, then we can again improve from the generic semi-regular complexity estimate (Equation (76)) by passing to the \mathbb{F}_q -Boolean Macaulay matrix. Again, we can then use Equation (65) to obtain the complexity of construction and Gaussian elimination on the \mathbb{F}_q -Boolean Macaulay matrices

$$\mathcal{O} \left((8 \cdot r_{\mathcal{H}}^2 - 4 \cdot r_{\mathcal{H}}) \cdot \left(\sum_{i=0}^{d_{\text{reg}}} \binom{2 \cdot r_{\mathcal{H}} + i - 3}{i} \cdot \binom{2 \cdot r_{\mathcal{H}} - 2}{i} \right) + 4 \cdot \left(\sum_{i=0}^{d_{\text{reg}}} \binom{2 \cdot r_{\mathcal{H}} - 2}{i} \right)^{\omega} \right). \quad (81)$$

In Table 6 we evaluate this complexity estimate. In addition, we show the complexity just for Gaussian elimination on the \mathbb{F}_q -Boolean Macaulay matrices, i.e. the complexity under the assumption that the Boolean Macaulay matrices are constructed “for free”. If we account for the cost of constructing the Boolean Macaulay matrices, then this method performs worse than the optimized Eigenvalue Method. However, it still beats the cryptanalysis of the Hydra designers for larger round numbers. Though, if we just consider the Gaussian elimination step, then this method slightly improves upon the Eigenvalue method.

Table 6: DRL Gröbner basis complexity estimate for Hydra via Equation (80) with $\omega = 2$.

Complexity (Bits)				
$r_{\mathcal{H}}$	d_{reg}	Boolean Gaussian Elimination	Boolean Semi-Regular Estimate	Semi-Regular Estimate [GØSW23]
20	16	74	91	89
29	23	108	130	131
31	25	116	140	142
33	27	125	149	153
34	28	129	154	159
39	32	148	176	183

Empirical F4 Working Degree. The Hydra designers performed small scale Gröbner basis experiments for Hydra with the F4 [Fau99] algorithm, see [GØSW22, Table 4]. We replicated their experiment with our OSCAR implementation over the prime field \mathbb{F}_{7741} . We report our results in Table 7, but as input system we use the substituted system from Section 4.2 which contains a zero-dimensional DRL Gröbner basis. Our experiments have been performed on an AMD EPYC-Rome (48) CPU with 94 GB RAM. Like the Hydra designers we observed that the empirical F4 working degree meets the semi-regular degree of regularity estimate.

Table 7: Highest working degree and running times for F4 in small scale Hydra polynomial systems over the prime field \mathbb{F}_{7741} .

$r_{\mathcal{H}}$	Our data								Grassi et al.'s data [GØSW22, Table 4]					
	3	4	5	6	7	8	9	10	6	7	8	9	10	11
Highest F4 working degree	3	3	4	5	5	6	7	8	5	5	6	7	8	8
Total time (s)	0.01	0.01	0.01	0.03	0.21	2.65	66.85	2295.7	0.1	0.9	13.4	293.8	8799.5	229606.8

Overall, we conclude that currently the most competitive algebraic attacks against Hydra directly apply polynomial system solving techniques to the zero-dimensional DRL Gröbner basis, see Table 4.

Acknowledgments

Matthias Steiner has been supported in part by the European Research Council (ERC) under the European Union's Horizon 2020 research and innovation program (grant agreement No. 725042) and the enCRYPTON project (grant agreement No. 101079319).

References

- [ACG⁺19] Martin R. Albrecht, Carlos Cid, Lorenzo Grassi, Dmitry Khovratovich, Reinhard Lüftenegger, Christian Rechberger, and Markus Schofnegger. Algebraic cryptanalysis of STARK-friendly designs: Application to MARVELLous and MiMC. In Steven D. Galbraith and Shihō Moriai, editors, *ASIACRYPT 2019, Part III*, volume 11923 of *LNCS*, pages 371–397. Springer, Heidelberg, December 2019. doi:10.1007/978-3-030-34618-8_13.
- [AGP⁺19] Martin R. Albrecht, Lorenzo Grassi, Léo Perrin, Sebastian Ramacher, Christian Rechberger, Dragos Rotaru, Arnab Roy, and Markus Schofnegger. Feistel

- structures for MPC, and more. In Kazue Sako, Steve Schneider, and Peter Y. A. Ryan, editors, *ESORICS 2019, Part II*, volume 11736 of *LNCS*, pages 151–171. Springer, Heidelberg, September 2019. doi:10.1007/978-3-030-29962-0_8.
- [AGR⁺16] Martin R. Albrecht, Lorenzo Grassi, Christian Rechberger, Arnab Roy, and Tyge Tiessen. MiMC: Efficient encryption and cryptographic hashing with minimal multiplicative complexity. In Jung Hee Cheon and Tsuyoshi Takagi, editors, *ASIACRYPT 2016, Part I*, volume 10031 of *LNCS*, pages 191–219. Springer, Heidelberg, December 2016. doi:10.1007/978-3-662-53887-6_7.
- [AW21] Josh Alman and Virginia Vassilevska Williams. A refined laser method and faster matrix multiplication. In Dániel Marx, editor, *32nd SODA*, pages 522–539. ACM-SIAM, January 2021. doi:10.1137/1.9781611976465.32.
- [Bar23] Augustin Bariant. Algebraic cryptanalysis of full Ciminion. Cryptology ePrint Archive, Paper 2023/1283, 2023. URL: <https://eprint.iacr.org/2023/1283>.
- [BBL⁺24] Augustin Bariant, Aurélien Boeuf, Axel Lemoine, Irati Ayala, Manterola, Morten Øygarden, Léo Perrin, and Håvard Raddum. The algebraic freelunch efficient Gröbner basis attacks against arithmetization-oriented primitives. Cryptology ePrint Archive, Paper 2024/347, 2024. URL: <https://eprint.iacr.org/2024/347>.
- [BBLP22] Augustin Bariant, Clémence Bouvier, Gaëtan Leurent, and Léo Perrin. Algebraic attacks against some arithmetization-oriented primitives. *IACR Trans. Symm. Cryptol.*, 2022(3):73–101, 2022. doi:10.46586/tosc.v2022.i3.73-101.
- [BFS04] Magali Bardet, Jean-Charles Faugère, and Bruno Salvy. On the complexity of Gröbner basis computation of semi-regular overdetermined algebraic equations. In *Proceedings of the International Conference on Polynomial System Solving*, pages 71–74, 2004.
- [BFSS13] Magali Bardet, Jean-Charles Faugère, Bruno Salvy, and Pierre-Jean Spaenlehauer. On the complexity of solving quadratic Boolean systems. *J. Complex.*, 29(1):53–75, 2013. doi:10.1016/j.jco.2012.07.001.
- [Buc65] Bruno Buchberger. *Ein Algorithmus zum Auffinden der Basiselemente des Restklassenringes nach einem nulldimensionalen Polynomideal*. PhD thesis, Universität Innsbruck, 1965.
- [CDG⁺17] Melissa Chase, David Derler, Steven Goldfeder, Claudio Orlandi, Sebastian Ramacher, Christian Rechberger, Daniel Slamanig, and Greg Zaverucha. Post-quantum zero-knowledge and signatures from symmetric-key primitives. In Bhavani M. Thuraisingham, David Evans, Tal Malkin, and Dongyan Xu, editors, *ACM CCS 2017*, pages 1825–1842. ACM Press, October / November 2017. doi:10.1145/3133956.3133997.
- [CG21] Alessio Caminata and Elisa Gorla. Solving multivariate polynomial systems and an invariant from commutative algebra. In Jean Claude Bajard and Alev Topuzoğlu, editors, *Arithmetic of Finite Fields*, pages 3–36, Cham, 2021. Springer International Publishing. doi:10.1007/978-3-030-68869-1_1.
- [CG22] Alessio Caminata and Elisa Gorla. Solving multivariate polynomial systems and an invariant from commutative algebra, 2022. Version: 7. arXiv:1706.06319.
- [CG23] Alessio Caminata and Elisa Gorla. Solving degree, last fall degree, and related invariants. *J. Symb. Comput.*, 114:322–335, 2023. doi:10.1016/j.jsc.2022.05.001.

- [CLO15] David A. Cox, John Little, and Donal O’Shea. *Ideals, Varieties, and Algorithms: An Introduction to Computational Algebraic Geometry and Commutative Algebra*. Undergraduate Texts in Mathematics. Springer International Publishing, 4 edition, 2015. doi:10.1007/978-3-319-16721-3.
- [DGGK21] Christoph Dobraunig, Lorenzo Grassi, Anna Guinet, and Daniël Kuijsters. Ciminion: Symmetric encryption based on Toffoli-gates over large finite fields. In Anne Canteaut and François-Xavier Standaert, editors, *EUROCRYPT 2021, Part II*, volume 12697 of *LNCS*, pages 3–34. Springer, Heidelberg, October 2021. doi:10.1007/978-3-030-77886-6_1.
- [DS13] Jintai Ding and Dieter Schmidt. Solving degree and degree of regularity for polynomial systems over a finite fields. In Marc Fischlin and Stefan Katzenbeisser, editors, *Number Theory and Cryptography: Papers in Honor of Johannes Buchmann on the Occasion of His 60th Birthday*, pages 34–49, Berlin, Heidelberg, 2013. Springer Berlin Heidelberg. doi:10.1007/978-3-642-42001-6_4.
- [Eis95] David Eisenbud. *Commutative Algebra: with a View Toward Algebraic Geometry*. Springer New York, New York, 1995. doi:10.1007/978-1-4612-5350-1.
- [Fau99] Jean-Charles Faugère. A new efficient algorithm for computing Gröbner bases (F4). *J. Pure Appl. Algebra*, 139(1):61–88, 1999. doi:10.1016/S0022-4049(99)00005-5.
- [Fau02] Jean-Charles Faugère. A new efficient algorithm for computing Gröbner bases without reduction to zero (F5). In *Proceedings of the 2002 International Symposium on Symbolic and Algebraic Computation*, ISSAC ’02, page 75–83. Association for Computing Machinery, 2002. doi:10.1145/780506.780516.
- [FGHR14] Jean-Charles Faugère, Pierrick Gaudry, Louise Huot, and Guénaél Renault. Sub-cubic change of ordering for Gröbner basis: A probabilistic approach. In *Proceedings of the 39th International Symposium on Symbolic and Algebraic Computation*, ISSAC ’14, page 170–177, New York, NY, USA, 2014. Association for Computing Machinery. doi:10.1145/2608628.2608669.
- [FGLM93] Jean-Charles Faugère, Patrizia Gianni, Daniel Lazard, and Teo Mora. Efficient computation of zero-dimensional Gröbner bases by change of ordering. *J. Symb. Comput.*, 16(4):329–344, 1993. doi:10.1006/jsco.1993.1051.
- [FM17] Jean-Charles Faugère and Chenqi Mou. Sparse FGLM algorithms. *J. Symb. Comput.*, 80:538–569, 2017. doi:10.1016/j.jsc.2016.07.025.
- [Frö85] Ralf Fröberg. An inequality for Hilbert series of graded algebras. *Math. Scand.*, 56:117–144, 12 1985. doi:10.7146/math.scand.a-12092.
- [GLR⁺20] Lorenzo Grassi, Reinhard Lüftenegger, Christian Rechberger, Dragos Rotaru, and Markus Schofnegger. On a generalization of substitution-permutation networks: The HADES design strategy. In Anne Canteaut and Yuval Ishai, editors, *EUROCRYPT 2020, Part II*, volume 12106 of *LNCS*, pages 674–704. Springer, Heidelberg, May 2020. doi:10.1007/978-3-030-45724-2_23.
- [GØSW22] Lorenzo Grassi, Morten Øygarden, Markus Schofnegger, and Roman Walch. From farfalle to megafono via ciminion: The PRF hydra for MPC applications. Cryptology ePrint Archive, Report 2022/342, 2022. <https://eprint.iacr.org/2022/342>.

- [GØSW23] Lorenzo Grassi, Morten Øyegarden, Markus Schofnegger, and Roman Walch. From farfalle to megafono via ciminion: The PRF hydra for MPC applications. In Carmit Hazay and Martijn Stam, editors, *EUROCRYPT 2023, Part IV*, volume 14007 of *LNCS*, pages 255–286. Springer, Heidelberg, April 2023. doi:[10.1007/978-3-031-30634-1_9](https://doi.org/10.1007/978-3-031-30634-1_9).
- [GRR⁺16] Lorenzo Grassi, Christian Rechberger, Dragos Rotaru, Peter Scholl, and Nigel P. Smart. MPC-friendly symmetric key primitives. In Edgar R. Weippl, Stefan Katzenbeisser, Christopher Kruegel, Andrew C. Myers, and Shai Halevi, editors, *ACM CCS 2016*, pages 430–443. ACM Press, October 2016. doi:[10.1145/2976749.2978332](https://doi.org/10.1145/2976749.2978332).
- [HvdH22] David Harvey and Joris van der Hoeven. Polynomial multiplication over finite fields in time $O(n \log n)$. *J. ACM*, 69(2), mar 2022. doi:[10.1145/3505584](https://doi.org/10.1145/3505584).
- [IKOS07] Yuval Ishai, Eyal Kushilevitz, Rafail Ostrovsky, and Amit Sahai. Zero-knowledge from secure multiparty computation. In David S. Johnson and Uriel Feige, editors, *39th ACM STOC*, pages 21–30. ACM Press, June 2007. doi:[10.1145/1250790.1250794](https://doi.org/10.1145/1250790.1250794).
- [KR00] Martin Kreuzer and Lorenzo Robbiano. *Computational Commutative Algebra 1*. Springer Berlin Heidelberg, Berlin, Heidelberg, 1 edition, 2000. doi:[10.1007/978-3-540-70628-1](https://doi.org/10.1007/978-3-540-70628-1).
- [KR05] Martin Kreuzer and Lorenzo Robbiano. *Computational Commutative Algebra 2*. Springer Berlin Heidelberg, Berlin, Heidelberg, 1 edition, 2005. doi:[10.1007/3-540-28296-3](https://doi.org/10.1007/3-540-28296-3).
- [KR16] Martin Kreuzer and Lorenzo Robbiano. *Computational Linear and Commutative Algebra*. Springer International Publishing, Cham, 1 edition, 2016. doi:[10.1007/978-3-319-43601-2](https://doi.org/10.1007/978-3-319-43601-2).
- [Laz83] Daniel Lazard. Gröbner bases, Gaussian elimination and resolution of systems of algebraic equations. In J. A. van Hulzen, editor, *Computer Algebra, EURO-CAL '83, European Computer Algebra Conference, London, England, March 28-30, 1983, Proceedings*, volume 162 of *Lecture Notes in Computer Science*, pages 146–156. Springer Berlin Heidelberg, 1983. doi:[10.1007/3-540-12868-9_99](https://doi.org/10.1007/3-540-12868-9_99).
- [LTW13] Sven Laur, Riivo Talviste, and Jan Willemsen. From oblivious AES to efficient and secure database join in the multiparty setting. In Michael J. Jacobson Jr., Michael E. Locasto, Payman Mohassel, and Reihaneh Safavi-Naini, editors, *ACNS 13*, volume 7954 of *LNCS*, pages 84–101. Springer, Heidelberg, June 2013. doi:[10.1007/978-3-642-38980-1_6](https://doi.org/10.1007/978-3-642-38980-1_6).
- [OSC24] OSCAR – open source computer algebra research system, Version 1.0.2, 2024. URL: <https://www.oscar-system.org>.
- [Par10] Keith Pardue. Generic sequences of polynomials. *J. Algebra*, 324(4):579–590, 2010. doi:[10.1016/j.jalgebra.2010.04.018](https://doi.org/10.1016/j.jalgebra.2010.04.018).
- [RS22] Arnab Roy and Matthias Steiner. Generalized triangular dynamical system: An algebraic system for constructing cryptographic permutations over finite fields, 2022. Version: 6. arXiv:[2204.01802](https://arxiv.org/abs/2204.01802).
- [Sag24] SageMath, the Sage Mathematics Software System (Version 10.3), 2024. URL: <https://www.sagemath.org>.

- [Sil00] John R. Sylvester. Determinants of block matrices. *Math. Gaz.*, 84(501):460–467, 2000. doi:10.2307/3620776.
- [Ste24] Matthias Johann Steiner. Solving degree bounds for iterated polynomial systems. *IACR Trans. Symm. Cryptol.*, 2024(1):357–411, 2024. doi:10.46586/tosc.v2024.i1.357-411.
- [Sto00] Arne Storjohann. *Algorithms for matrix canonical forms*. Doctoral thesis, ETH Zurich, Zürich, 2000. Diss., Technische Wissenschaften ETH Zürich, Nr. 13922, 2001. doi:10.3929/ethz-a-004141007.
- [Str69] Volker Strassen. Gaussian elimination is not optimal. *Numer. Math.*, 13(4):354–356, Aug 1969. doi:10.1007/BF02165411.
- [Ten19] Andrea Tenti. *Sufficiently overdetermined random polynomial systems behave like semiregular ones*. PhD thesis, University of Bergen, 2019. URL: <https://hdl.handle.net/1956/21158>.
- [Tof80] Tommaso Toffoli. Reversible computing. In Jaco de Bakker and Jan van Leeuwen, editors, *Automata, Languages and Programming*, pages 632–644, Berlin, Heidelberg, 1980. Springer Berlin Heidelberg. doi:10.1007/3-540-10003-2_104.