

# Assemblage: Automatic Binary Dataset Construction for Machine Learning

**Chang Liu\***

*Syracuse University*

CLIU57@SYR.EDU

**Rebecca Saul\***

*Booz Allen Hamilton*

SAUL\_REBECCA@BAH.COM

**Yihao Sun**

*Syracuse University*

YSUN67@SYR.EDU

**Edward Raff**

*Booz Allen Hamilton*

RAFF\_EDWARD@BAH.COM

**Maya Fuchs**

*Booz Allen Hamilton*

FUCHS\_MAYA@BAH.COM

**Townsend Southard Pantano**

*Syracuse University*

TGSOUTH@SYR.EDU

**James Holt**

*Laboratory for Physical Sciences*

HOLT@LPS.UMD.EDU

**Kristopher Micinski**

*Syracuse University*

KKMICINS@SYR.EDU

Reviewed on OpenReview: <https://openreview.net/forum?id=XXXX>

## Abstract

Binary code is pervasive, and binary analysis is a key task in reverse engineering, malware classification, and vulnerability discovery. Unfortunately, while there exist large corpuses of malicious binaries, obtaining high-quality corpuses of benign binaries for modern systems has proven challenging (*e.g.*, due to licensing issues). Consequently, machine learning based pipelines for binary analysis utilize either costly commercial corpuses (*e.g.*, VirusTotal) or open-source binaries (*e.g.*, coreutils) available in limited quantities. To address these issues, we present ASSEMBLAGE: an extensible cloud-based distributed system that crawls, configures, and builds Windows PE binaries to obtain high-quality binary corpuses suitable for training state-of-the-art models in binary analysis. We have run ASSEMBLAGE on AWS over the past year, producing 890k Windows PE and 428k Linux ELF binaries across 29 configurations. ASSEMBLAGE is designed to be both reproducible and extensible, enabling users to publish “recipes” for their datasets, and facilitating the extraction of a wide array of features. We evaluated ASSEMBLAGE by using its data to train modern learning-based pipelines for compiler provenance and binary function similarity. Our results illustrate the practical need for robust corpuses of high-quality Windows PE binaries in training modern learning-based binary analyses. ASSEMBLAGE can be downloaded from <https://assemblage-dataset.net/>.

---

\*. Equal contribution

## 1 Introduction

Binary analysis, the task of understanding and analyzing an executable binary program, is extraordinarily labor-intensive. Practitioners often spend hours to weeks manually analyzing a single program (Raff et al., 2020). The development of automated binary analysis tools has also proven to be extremely labor-intensive. Historically, such tools have relied on careful and judicious software engineering efforts to handle all corner cases, or used SAT solvers and similar data structures to resolve as many conditions as possible (Liu et al., 2023b). Given this high human effort, it is unsurprising that an increasing number of binary analysis methods use machine learning to help automate such efforts. This includes low-level tasks such as function disassembly (Yu et al., 2022), and high-level tasks like malware detection (Rokon et al., 2020) or variable name identification (Lacomis et al., 2019; Chen et al., 2022) which leverage these lower-level results.

However, significant issues in data availability have hampered the development of machine learning-based binary analysis for decades (Abt and Baier, 2014; Raff and Nicholas, 2020). Disassembly and decompilation require a mapping between the original true source or assembly code and the corresponding bytes of binary instructions, but it is non-trivial to collect and maintain such a mapping. Malware detection requires access to a collection of “benign” programs to train on, but can not be legally distributed due to copyright and license concerns. The situation is particularly bad for Windows PE binaries: while Windows is the most frequent target of malware, modern binary analysis systems train almost exclusively on Linux ELF binaries. Toolchain identification requires knowledge of the entire compilation process and of a variety of compiler settings that are simply not recorded in the original file. Binary function similarity requires having ground truth of functions that are semantically equivalent but written or compiled differently; most existing models rely on coding competition data that does not reflect the diversity of real-world code. The ad-hoc approaches taken by prior works to tackle these issues further complicate the reproducibility of these methods due to the infrastructure challenges in setting up an environment to build the same tools and perform complex data pre-processing (Marcelli et al., 2022; Raff, 2019, 2021; Gundersen et al., 2022). Moreover, authors often do not have the necessary licenses or do not make the code publicly available for others to extend the work.

We introduce ASSEMBLAGE, a tool that makes significant progress towards overcoming all of these challenges. ASSEMBLAGE is a framework for crawling code hosting platforms, downloading open-source projects, compiling them with multiple different compiler versions and settings, and recording the necessary information to reconstruct byte-level mappings from the output back to the source code. By using open-source code targets from GitHub, we obtain greater diversity in programs, resolve licensing/distribution issues, and provide detailed ground truth to support all of the aforementioned research areas. This alleviates the concerns with non-semantic preserving modifications (Fleshman et al., 2018) and the exorbitantly expensive cost and more limited diversity of binary re-writing (Wong et al., 2023; Boutsikas et al., 2021). ASSEMBLAGE is designed to be extensible so that additional sources of code, compilers, and feature extractors can be added for further functionality. ASSEMBLAGE datasets can be further distributed as a list of repositories and settings so that issues with mixed-license repositories (e.g., GPL and BSD) do not make a binary-based

distribution unlicensable. Finally, we have designed and tested the system to ensure the reproducibility of datasets built by ASSEMBLAGE.

Modern binary analysis systems use ever-complex models, with the recent switch to large-language models (LLMs) necessitating orders-of-magnitude more data given the rapidly increase in network size and number of parameters. In Section 2 we survey several of these efforts, observing that the largest system trains only 48k Linux ELF binaries. We designed ASSEMBLAGE to produce large, diverse corpuses of binaries for training these state-of-the-art models at unprecedented scale. Our experiments running ASSEMBLAGE over the past year on AWS has produced a large corpus of benign Windows PE (890k) and Linux ELF (428k) binaries. ASSEMBLAGE clearly tracks source-to-binary provenance (down to the instruction level, in the case of Windows PE binaries) to provide a rich array of features and facilitate compliance with licensing and distribution. ASSEMBLAGE’s design facilitates a wide degree of customization and extension, allowing almost every aspect of its pipeline to be customized to suit the needs of modern, data-intensive binary analysis tools.

Our contributions include:

- ASSEMBLAGE, a cloud-based distributed system carefully engineered to automatically construct diverse corpuses of high-quality Windows PE binaries while ensuring compliance with licensing and terms of service.
- An evaluation of ASSEMBLAGE’s scalability and reproducibility, generating over 890k binaries over 20 weeks.
- The ASSEMBLAGE Windows and Linux datasets, consisting of 890k and 428k binaries respectively, with a total of 29 different combinations of CPU architecture, optimization level, compiler, compiler version, and other compiler flags.
- Three case studies that demonstrate ASSEMBLAGE’s application to (a) compiler provenance detection and (b) function similarity identification. Our case studies demonstrate the need for ASSEMBLAGE’s rich features, particularly for corpuses of Windows PE binaries.

## 2 Related Work and Open Challenges

**Prior Work: Crawling Open Source Repositories** Significant prior work has focused on crawling open-source repositories to build artifacts. For example, Sourcer (Linstead et al., 2007) crawled SourceForge to create a corpus of software for source-code similarity. More recent work targets GitHub due to its current dominance. This includes projects such as GHTorrent, which crawls and indexes GitHub (Gousios, 2013), along with other work focusing on improving crawling technology (Barpis et al., 2020). The open-source tool GHCC builds Linux-based GitHub repositories in batch mode and supports several other systems (such as DIRTY, XDA, and DIRE) (Lacomis and Hu, 2020).

ASSEMBLAGE distinguishes itself from prior work by offering multi-node scalability, end-to-end reliability, an extensible interface, and deep integration with Windows toolchains, and a comparison is shown in Table 1. To the best of our knowledge, there is no preexisting work that provides a systematic and replicable solution to generate Windows binaries from a wide range of sources. In fact, much of the recent work applying machine learning techniques

Table 1: Binary corpuses—ASSEMBLAGE vs. the literature

Dataset	Binaries	Functions	Toolchain	Dataset Format	Public
<b>Assemblage-WinPE</b>	<b>890k</b>	<b>252M</b>	<b>MSVC</b>	<b>Binaries + PDB</b>	<b>✓</b>
<b>Assemblage-WinPE-Licensed</b>	<b>97k</b>	<b>41M</b>	<b>MSVC</b>	<b>Binaries + PDB</b>	<b>✓</b>
<b>Assemblage-LinuxELF</b>	<b>428k</b>	<b>316M</b>	<b>GCC/Clang</b>	<b>Binaries</b>	<b>✓</b>
<b>Assemblage-LinuxELF-Licensed</b>	<b>211k</b>	<b>186M</b>	<b>GCC/Clang</b>	<b>Binaries</b>	<b>✓</b>
EMBER	1.1M	undisclosed	undisclosed	Extracted features	Features
PassTell	552	149k	GCC/Clang/ICC	Extracted features	✓
DIRE	164k	3M	GCC	Binaries	✓
SPEC(XDA)	3.1k	9.75k	GCC/ICC/MSVC	Custom format	✓
GHCC (DIRTY)	75k	1M	GCC	Binaries	✓
VirusShare	67M	undisclosed	undisclosed	Binaries	✗
BinaryCorp-26M(jTrans)	48k	25.8M	GCC	Binaries	✓
SOREL-20M	10M	undisclosed	undisclosed	Binaries	✓

to binary analysis tasks (e.g. (Du et al., 2022; Wang et al., 2022)) relies on custom crawlers that *cannot* be extended to Windows PE binaries due to GUI-based toolchains.

**The PE Binary Availability Crisis** The challenges of obtaining and distributing benign Windows PE executables continues to push modern work to rely upon manually-curated corpora of Linux binaries, or, alternatively, on paid services. For those who can afford it, VirusTotal has become the de-facto standard in malware classification due to its offering of benign binaries (Salem et al., 2021; Zhu et al., 2020b,a). For those who cannot, there are very few other options. While the distribution of malicious binaries is unfettered by licensing restrictions (*e.g.*, VirusShare by Roberts (2011)), these restrictions can complicate distribution of benign corpuses of PE binaries, subsequently inhibiting reproducibility of machine-learning-based binary analysis tools. Additionally, even when data is available, it is often in preprocessed form (*e.g.*, weights or features) that precludes its application to novel tasks. For example, while the popular EMBER data set includes 300k malicious and 300k benign Windows PE binaries, only EMBER’s features are public, not the binaries themselves (Anderson and Roth, 2018). While much work uses open-source Linux binaries (*e.g.*, DIRE by Lacomis et al. (2019)), our case studies show that the utility of Linux-based training data for Windows-based tasks is unclear.

Consistent with our description of the landscape, there were many systems to which we were unable to apply ASSEMBLAGE, due primarily to the lack of (a) available comparison data or code, or (b) support for Windows PE binaries. For example, work such as XDA makes data available only in preprocessed form (Pei et al., 2021). Similarly, tools such as PalmTree (a model for learning instruction embeddings) do not include implementations of the downstream tasks necessary to perform end-to-end comparison (Li et al., 2021b). Finally, almost all systems (such as Debin (He et al., 2018), Symmlm (Jin et al., 2022), and DIRTY (Chen and Sun, 2022)) work only on Linux binaries, relying upon DWARF or ELF-specific details for feature extraction. We speculate that the development of machine-learning-based binary analysis systems is significantly hampered by the serious costs involved with obtaining large benign corpora of PE binaries.

**Models Continue to Grow; Binary Datasets Must Keep Up** The most recent developments in binary analysis have been driven by the success of Large Language Models

(LLMs) for natural language tasks. Encouraged by the impressive performance of models like BERT (Devlin et al., 2019a) and GPT-4 (OpenAI, 2023), researchers have adapted the methods of natural language processing to apply to the domain of binary executables. One branch of work has focused on building general assembly language models, which can be fine-tuned to perform a wide variety of tasks (Li et al., 2021b; Artuso et al., 2022; Koo et al., 2021; Zhu et al., 2023). Other work presents models with specific downstream tasks in mind, including binary code similarity detection (Wang et al., 2022; Ahn et al., 2022; Gu et al., 2023; Liu et al., 2023a), compiler provenance identification (He et al., 2022), vulnerability detection (Yu et al., 2021), and malware detection (Li et al., 2021a; Hamad et al., 2021; Wu et al., 2021).

While these LLM-inspired models have advanced the state of the art in many areas of binary analysis, they demand orders-of-magnitude more input data to avoid overfitting, magnifying the effect of PE binary availability crisis. LLMs derive their name partially from the fact that they are trained on massive amounts of data, and it is well known that LLMs can achieve significantly better performance and even unlock emergent abilities at scale (Brown et al., 2020; Wei et al., 2022). However, a surprising amount of existing work applies LLMs to relatively small input corpuses. We were able to find dataset breakdowns for 10 of 13 models mentioned in the previous paragraph; the average number of binaries used to compose the training set for these models is roughly over 13k (median 3.7k). Two models are trained on fewer than 200 binaries, with Liu et al. (2023a) being trained on only 48 binaries. Wang et al. (2022) and Zhu et al. (2023) are trained with the BinaryCorp dataset, which, at 48,130 (Linux) binaries, is more than twice the size of the next largest dataset used. We hope that the orders-of-magnitude greater amount of data made available by ASSEMBLAGE (890k Windows PE and 428k Linux ELF binaries) will further improve the performance of these state-of-the-art tools.

**Modern Efforts in Binary Analysis Ignore Windows** We found that nearly half of the transformer-based models discussed above are trained largely, or even primarily, on executables from standard Linux packages such as *coreutils*, *binutils*, *diffutils*, *findutils*, *busybox*, *libcurl* and *openssl*. While these packages are well-written and easy to access, compile, and parse, they do not align with the quality and characteristics typically found in the codes written by the majority of programmers. The over-reliance on common Linux packages for training exemplifies a major problem with these training datasets; out of the thirteen transformer-based models discussed, only one, Wu et al. (2021), is trained using Windows data. Moreover, the reliance on small collections of Linux binaries extends beyond transformer-inspired models (Marcelli et al., 2022; Kim et al., 2022; Al-Kaswan et al., 2023).

With the increasing use of binary analysis in security-relevant settings, the absence of publicly available corpora of benign Windows binaries is a critical concern. The difficulty of obtaining Windows PE data in academic literature is prevalent in related domains like malware detection that rely on small datasets (Joyce et al., 2022), effect sizes (Patel et al., 2023), and label noise (Joyce et al., 2021a,b, 2023), which generally depend on VirusShare and VirusTotal for data. An examination of files uploaded to VirusShare in 2023 indicates that 40.38% of the roughly 1.8 million malware samples are Windows binaries, whereas

less than one percent are ELF binaries (Roberts, 2011).<sup>1</sup> Given the prevalence of Windows executables, and the fact that Windows accounts for roughly seventy percent of global operating system market share (Statcounter, 2023), it is troubling that nearly all the recent literature on machine learning approaches to binary analysis uses Linux binaries as training data. This is especially worrying because, as we demonstrate in Sections 6.2 and 6.3, models trained on Linux binaries do not necessarily generalize to the Windows domain. Therefore, in order to produce useful machine learning models for binary analysis, it is necessary at a minimum to test, and likely necessary to train, these models on Windows data. We hope that will ASSEMBLAGE fill the dataset gap to enable the application of modern efforts to Windows PE executables.

**Comparing Assemblage and Preexisting Corporuses** Table 1 outlines a collection of binary corporuses from the literature, along with the largest corpus generated by ASSEMBLAGE on top. The data set name is shown on the left, followed by the number of binaries, the number of functions (across all binaries), and the toolchains. The next column illustrates the dataset format: ASSEMBLAGE provides a detailed source-to-binary mapping as part of the compilation process, and generates Program DataBase (PDB) files for use with reverse engineering tools such as IDA Pro. EMBER is a popular data set of Windows PE binaries, but the raw binaries are not public due to licensing restrictions; instead, EMBER provides only extracted features (Anderson and Roth, 2018). PassTell’s data set is also in the form of features, though its source is available and the basis of one of our case studies. While Windows PE binaries from XDA (generated by GHCC) are available, the total number of functions is relatively small (roughly 10k) (Pei et al., 2021); in more recent work using transformer learning, the XDA authors use Linux binaries gathered from open-source repositories to attain a sufficient amount of training data (Chen et al., 2022).

In sum, the vast bulk of work in modern binary analysis uses corporuses which are either (a) far too small for modern applications, or (b) consist exclusively of ELF binaries. ASSEMBLAGE addresses the limitations of these existing datasets by providing large corporuses of both Linux and Windows binaries, complete with provenance and attribution to ensure compliance with licensing concerns and exposing the source-to-binary mapping.

### 3 Assemblage’s Design and Implementation

We designed ASSEMBLAGE as a cloud-based distributed system tailored to produce robust, reproducible, and high-quality binary corporuses. Figure 1 illustrates ASSEMBLAGE’s principal components.

**Distributed Architecture** ASSEMBLAGE is designed to run as a distributed system on any cloud infrastructure, implementing a star topology system architecture. It consists of a central *coordinator* node, an adaptive worker pool, and a database interface. The system is designed to be resistant to component failure and endure high throughput. ASSEMBLAGE provides rich APIs to enable wide flexibility in configuration, deployment, and extension.

---

1. The other major file types are PDF, which accounts for roughly 25% of files, and Unknown, which accounts for 32% of files and captures files whose types could not be parsed. Files in the unknown category include data files, some scripts, ASC files, and source code.

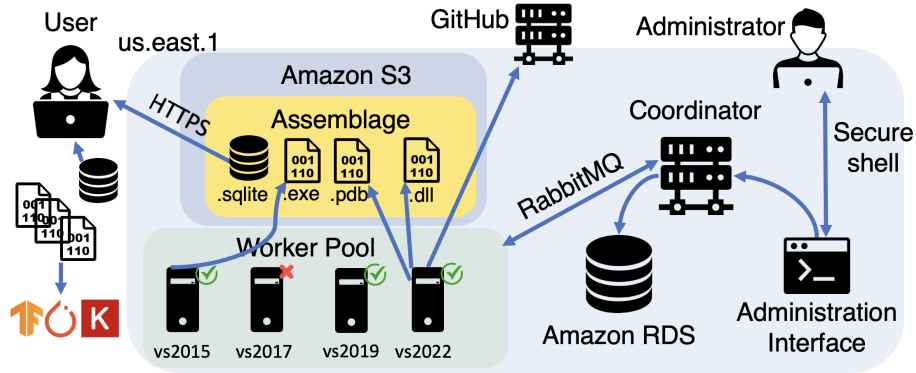

Figure 1: ASSEMBLAGE architecture. A user downloads a corpus built via a worker pool on AWS, driven by the coordinator, which is configured via an interface accessed via secure shell.

ASSEMBLAGE is driven by the *coordinator* node, which is responsible for configuration, task management, and database updating. Administrators communicate with ASSEMBLAGE through a command-line interface provided by the coordinator. Then, a RabbitMQ message broker performs task management via a single-producer multi-consumer message queue. Finally, the coordinator dispatches tasks to specific channels of workers in the worker pool and, once a worker marks a task as complete, updates its database accordingly.

ASSEMBLAGE’s worker nodes form an adaptive pool where each worker listens to one designated task channel. New workers can join the pool by registering with the coordinator and listening to a specific channel. Conversely, the coordinator can mark a worker as offline if it doesn’t send back a heartbeat signal within an allotted time period.

The modular design of ASSEMBLAGE ensures that the unavailability of certain services does not result in a system-wide failure. The worker pool protects the system from cascading failures, so that the crash of one worker does not lead to a system-wide collapse. The message queue helps system communication remain stable as the worker pool scales. In practice, we have deployed up to 100 workers concurrently without issue.

**Task Lifecycle** We will first describe our GitHub crawler, though ASSEMBLAGE abstracts around input streams for source code, and we also include input sources for local (on-disc) repositories, Arch Linux’s AUR, and Microsoft’s `vcpkg`. The crawler begins by sending queries to GitHub’s APIs to discover new repositories. The coordinator then assembles results into build tasks, which instruct a worker to clone the repository and build it in a specific configuration. Workers listening to the channels will clone and build the binaries indicated in each task, and store the collected binaries in a designated storage location (typically an AWS S3 Bucket). Build workers are implemented by instantiating an abstract interface; we implemented builders for both Windows PE and Linux ELF binaries. On Windows, ASSEMBLAGE uses the Microsoft Visual Studio toolchain, incorporating a set of automation scripts to overcome Visual Studio’s reliance on GUI-based user interfaces. On Linux, we implement workers for both GCC and Clang, using Docker to facilitate flexible and isolated deployment.

**Tracking Build Provenance** Most prior work that built datasets of executables relied on disassembly tools to extract function information from binaries. For example, Wang et al. (2022), Ahn et al. (2022), and Marcelli et al. (2022) use IDA Pro to retrieve function information, while Du et al. (2022) uses objdump. Though significant engineering effort has gone into improving such disassembly tools over the years, they still do not work flawlessly, especially on Windows binaries. For example, IDA Pro can only infer function boundaries, but not names, on Windows PE binaries. Moreover, there is no guarantee as to the correctness of the recovered function information, especially when certain sections of information are stripped entirely (Wang et al., 2022). To address the shortcomings inherent in using tools such as IDA Pro, ASSEMBLAGE is designed to carefully track build provenance, enabling the collection of ground truth compiler flags and settings.

ASSEMBLAGE’s methods for recording build provenance are operating system dependent. For Linux binaries, we keep the compiled binary’s symbol table, unstripped, to preserve function information. This information is then added to the SQLite database corresponding to the dataset. For Windows binaries, in addition to collecting the binaries themselves, ASSEMBLAGE also collects Program Database (PDB) files and other log files generated by the Microsoft Visual C++ compiler. These PDB files contain essential debug information that can be leveraged by binary analysis tools such as IDA Pro and Ghidra to associate source code with the bytes of compiled binaries and generate precise analysis outcomes. For the ease of generating training labels from PDB files, ASSEMBLAGE processes PDB files utilizing Microsoft Debug Interface Access (DIA) SDK’s sample code “DIA2dump” (Microsoft, 2022a), then stores the files in exported ASSEMBLAGE datasets. Additionally, the compilation metadata recorded in the PDB files is stored in the dataset’s SQLite database for portability.

By controlling the metadata passed to compiler during compilation, ASSEMBLAGE ensures that the records in its SQLite table are accurate. To compare the utility of ASSEMBLAGE’s metadata to that collected by previous methods, we passed a subset of ASSEMBLAGE Windows binaries, containing a total of 23.7 million functions, to IDA Pro 8.2. IDA was unable to recover the names of nearly 10.7 million (45%) of those functions, instead returning a generic `subroutine_location` label (e.g. `sub_10013040`). The incidence of irretrievable function names in ASSEMBLAGE’s metadata, by comparison, was  $6 \cdot 10^{-7}\%$ . This demonstrates that ASSEMBLAGE provides more complete and more accurate binary executable data than earlier dataset collection procedures.

**Serializing “Recipes” for Reproducibility** The distribution of binary corpuses is complicated by the data size, licensing issues, and the need to accommodate application-specific features (e.g., control-flow graphs extracted via a commercial tool). To solve these issues, ASSEMBLAGE supports distribution of datasets via “recipes,” compact Python bootstrap scripts that capture all information necessary to reconstruct a dataset. Given a recipe, users can replicate the state of a running ASSEMBLAGE instance, as details about worker nodes and their associated instance types, build configurations, and repository URLs are all included. Recipes take advantage of ASSEMBLAGE’s declarative API to enable wide flexibility in system operation. For example, via a small change in the recipe, ASSEMBLAGE can be switched to either continuously crawl for new repositories, replicate an existing set of repositories, or build a set of repositories from a local disk. This allows sharing a smaller



“recipe” over a larger data dump and a backup mechanism in the event of data corruption or hardware failure.

## 4 The Assemblage Datasets

**890k Windows-Github PE Dataset** We constructed a dataset of 890K Windows PE binaries as follows: starting from 4 million crawled GitHub repositories dating from 2008 to 2023, we discarded repositories that had fewer than 10 files, were smaller than 50KB in size, lacked a `README.md` file containing the string “Visual Studio”, or lacked a solution file supporting Microsoft Visual Studio tool chains. We were left with 179,548 repositories, from which ASSEMBLAGE was then able to build and store binaries using our Microsoft Visual Studio toolchains. Build configurations varied in toolchain version (Visual Studio 2015, 2017, 2019, and 2022), optimization level (0d, 01, 02, 0x), CPU architecture, and Debug/Release mode. In sum, we ended up with 847,856 executable (`.exe`) files and 43,507 dynamically-linked library (`.dll`) files, along with PDB files for each binary. In total, we accumulated 2TB worth of data, of which the executables (`.exe` and `.dll` files) took 200GB. To conform with ethical data distribution practices, we recorded license information from crawled repositories when available. Table 2 shows the distribution of licenses present among the GitHub repositories in our corpus; consistent with our observation of many small repositories, 158,624 of the 179,548 repositories have no license.

Table 2: Top licenses in GitHub datasets.

License	Windows-GitHub	Linux-GitHub
MIT	7258	6762
GPL	3078	2845
Apache	1168	859
BSD	313	609
CC	94	50
BSL	22	49

We measured our dataset along a variety of dimensions to demonstrate its quality and diversity. Figure 2 shows a histogram of sizes of binaries from our (a) Windows binaries from GitHub, (b) `vcpkg` (c) Linux binaries from GitHub corpuses. Our Windows-GitHub binaries were the smallest overall, with an average size of 143KB. Manual inspection revealed many student projects, basic utilities, and starter codes among our GitHub dataset. However, in absolute terms, our Windows-GitHub dataset still contains a substantial number of large binaries, including 26,549 binaries over 0.5MB.

We also present a breakdown of our Windows-Github dataset by compiler and optimization level (Table 4). The number of binaries at each compiler version and optimization is not equal, due to unevenly distributed computing power among ASSEMBLAGE worker nodes, changes to the availability of repositories, restricted running time, and the limited availability of some configurations in solution files. To further investigate the varying number of binaries under each build configuration, we recorded the error message encountered during build failures, which we summarize in Table 3. Over the whole dataset, the most

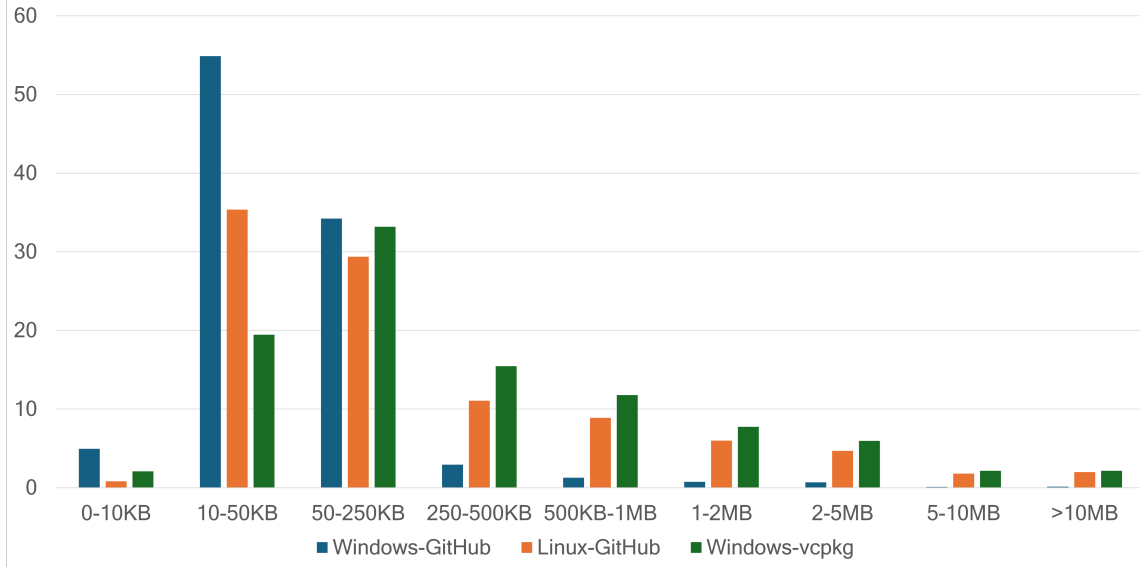

Figure 2: Binary size distribution of Windows on GitHub, vcpkg and Linux on GitHub data.

Table 3: Most common error codes from ASSEMBLAGE Windows dataset

Error Code	Ratio	Memo
MSB4126	47%	Invalid specified solution configuration
C1083	18%	Missing source file
MSB8036	8%	Specified Windows SDK version was not found
MSB3202	3%	Missing project file
MSB4025	3%	The imported project file loading error

common causes of build failure are related to compiler infrastructure, such as invalid solution configurations, Windows SDK errors due to upgrading, invalid or missing project files, and other compilation errors. Although we tried to mitigate the errors caused by missing files by installing a wide range of SDK libraries, complete coverage was infeasible, and thus certain library versions were absent from our worker environment. We also did our best to minimize invalid configuration errors by minimally modifying variables in vcproj files and using `devenv` from MSVC to upgrade solution files when appropriate.

Moreover, we manually inspected the log files associated with certain build configurations that had particularly low success rates: `v141-01-Debug-x64`, `v141-0x-Debug-x64`, and `v140-01-Release-x86`. We present the results in Table 5. We found that 86% of `v141-01-Debug-x64` and 66% of `v141-0x-Debug-x64` failures produce error code MSB4126, which indicates that the solution configuration is invalid. By comparison, the dominant error code for `v140-01-Release-x86` is C1083, which indicates that a certain file is missing or wrong.

Table 4: Configuration distribution on three datasets.

OS	Source	Compiler	Opt.	Count
Windows PE	GitHub	MSVC-v140	O1	60126
			O2	165866
			Ox	100831
		MSVC-v141	O1	6113
			O2	78203
			Od	86841
		MSVC-v142	Ox	7470
			O1	87497
			O2	50055
		MSVC-v143	Od	72613
			O1	80243
			Od	57011
	vcpkg	MSVC-v120	Ox	37302
			O1	952
			O2	945
MSVC-v142		Od	956	
		Ox	926	
		O1	2160	
MSVC-v143		O2	2142	
		Od	2187	
		Ox	2145	
Linux ELF	GitHub	GCC-11.4.0	O1	3081
			O2	3078
			Od	3074
		Clang-14.0.0	Ox	3083
			Od	50338
			O1	49860
Linux ELF	GitHub	GCC-11.4.0	O3	50995
			Oz	22030
			Od	50338
		Clang-14.0.0	O1	63188
			O2	65934
			O3	69082

We also inspected the function information corresponding to our Windows-Github PE dataset. We found that out of 252M functions, there are 14M unique function names, and 138M unique function hashes. ASSEMBLAGE is also able to store source code for 17M functions in its SQL database. We also observed significant variation in the number of functions per binary, which we illustrate in Figure 3. Finally, we examined the relationship between a binary’s size and the functions it contains. Counter-intuitively, the number

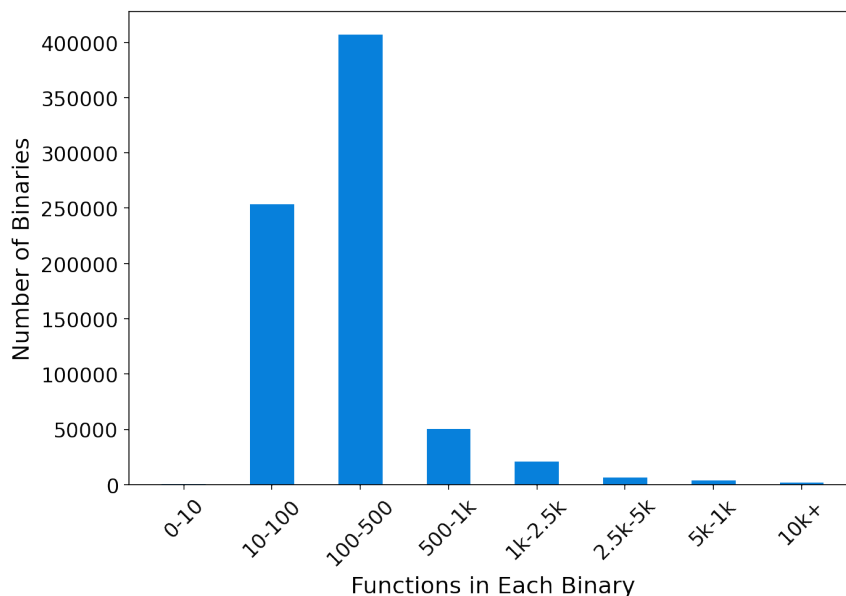

Figure 3: Function distribution of each binary.

of functions in a binary is not correlated with the size of that binary, as these variables have a Pearson correlation coefficient of 0.22. Furthermore, the size of functions within a binary has a 0.49 correlation coefficient to the binary size, but no correlation to the number of functions in the binary. We unexpectedly conclude that binary size doesn’t have a strong correlation with either the number of functions nor the average function size in a binary. Moreover, the existence of function level information provides insights into the behavior patterns of specific compilers. For example, in 2017 Visual Studio implemented stack-based buffer protection by inserting security cookies, and we can locate more than 744k `__security_init_cookie` functions with 151k unique hashes. These function level information provided by ASSEMBLAGE presents valuable data for not only machine learning research, but also a potential of application to a wide range of research areas like security and binary analysis.

**25k Windows vcpkg Dataset** Upon examining our Windows-Github dataset, we observed that only 4.7% of the corpus consisted of library files. To address this deficiency and provide coverage of Windows’ statically-linked and dynamically-linked libraries, we adapted ASSEMBLAGE to build binaries from `vcpkg` (Microsoft, 2022b), a dataset of 2,185 actively-developed, well-maintained, and widely-used packages. `vcpkg` consists of many commonly used C++ libraries, including graphics and UI-related libraries. Additionally, every project hosted on `vcpkg` is licensed, which makes this dataset easy to redistribute.

Our `vcpkg` worker takes advantage of the native commands of `vcpkg`, and we modified the package manager’s original build script to pass custom variables and flags to its compiler. In this way, we harvested a diverse Windows PE library corpus from `vcpkg`, comprising 24905 binaries, along with their `pdb` files, from 2078 different projects. Only 110 of these projects are also present in our Windows-Github dataset, demonstrating the added diversity

Table 5: Error codes for specific build configuration

	Flags	MSB4126	C1083	MSB8036	MSB4025	Others
MSVC-v140	O1-Release-x86	25%	34%	0%	1%	40%
	O2-Debug-x64	82%	5%	0%	0%	13%
	O2-Release-x86	25%	34%	0%	1%	40%
	Ox-Release-x64	21%	36%	0%	0%	43%
MSVC-v141	O1-Debug-x64	86%	3%	0%	4%	6%
	O2-Release-x86	30%	24%	0%	6%	40%
	Od-Release-x86	37%	21%	0%	6%	35%
	Ox-Debug-x64	66%	10%	0%	6%	18%
MSVC-v142	O1-Release-x64	20%	23%	30%	1%	26%
	O2-Release-x86	25%	22%	28%	1%	25%
	Od-Debug-x64	69%	7%	12%	0%	12%
MSVC-v143	O1-Debug-x86	25%	18%	33%	6%	18%
	Od-Debug-x64	84%	4%	2%	4%	6%
	Ox-Release-x86	18%	36%	16%	2%	28%

that is present in our `vcpkg` dataset. Similarly to the Windows-Github dataset, `vcpkg` binaries were built using 4 different versions of the Microsoft Visual Studio toolchain, as well as with 4 optimization levels (Od, O1, O2, O3). Finally, as illustrated in Figure 2, the size of the binaries in our `vcpkg` dataset is larger than the size of those in our Windows-GitHub dataset. The `vcpkg` binaries were 2124 KB on average, compared to 143KB for Windows-Github binaries, with a small number (roughly 500) of `vcpkg` binaries measuring more than 10 MB.

**Proof-of-Concept Linux Dataset** Motivated by the scarcity of corpuses of benign Windows PE binaries, we have focused our efforts on building such executables. However, to ensure ASSEMBLAGE’s API was sufficiently expressive, we also added several Linux builders. Our prototype Linux crawler traverses GitHub and searches for `Makefiles` to identify potential Linux ELF projects. Among 4 million crawled repositories, ASSEMBLAGE recognized 367,207 repositories that include a `Makefile`. We created 8 build configurations, four using GCC (`-00`, `-01`, `-03`, and `-0Z`) and four using Clang (`-00`, `-01`, `-02`, and `-03`).

Similar to what we did when building our Windows PE database, we deployed ASSEMBLAGE to AWS with the same coordinator, but with workers on different EC2 instances. In sum, ASSEMBLAGE generated 428,884 Linux binaries from 30,856 GitHub repositories. The histogram of the file size distribution of our Linux ELF dataset is shown in Figure 2, the composition of compiler and optimization level of the dataset is presented in Table 4, and the overall dataset size is recorded in Table 1. Interestingly, we observe a much higher frequency of licensed repositories in our Linux-Github dataset; nearly half of our Linux-Github binaries have licenses, compared to only 11% of our Windows-Github binaries.

Generally, our Linux builder failed more often than our Windows PE builder (a success rate of 7% compared to the 30% on Windows), but produced larger files in the projects that it did build. Though it is natural to be concerned about build failures during the dataset

creation process, these errors are not introduced by ASSEMBLAGE, as we simply use regular expression to substitute the compiler flags stored in the Make files, then call make to start the building. Indeed, a manual inspection confirmed that most of the build errors resulted from errors in the repository’s source code or Make file.

In addition to the GitHub crawler, we also built a proof-of-concept crawler and builder that leverages the Arch User Repository (AUR) for source code. Users can set the configuration by providing custom makepkg.conf for each project. While the AUR repositories are well maintained by the community and open-sourced, due to the rate limits and ethical concerns, we did not deploy builders to generate a large scale dataset from AUR. However, our proof-of-concept crawler demonstrates that ASSEMBLAGE can be configured to work with a variety of package managers in order to harvest binaries.

**Assemblage’s SQLite Database** A typical ASSEMBLAGE dataset consists of both (a) an SQLite database of metadata and (b) an archive of binaries (either as a .tar or manually via the Amazon S3 interface). The SQL database provides a logical specification of a collection of binary files, currently .exes and .dlls. The user queries the SQLite database to perform application-specific feature extraction (e.g., identifying pairs of sibling functions for triplet learning), and often feeds the binaries into a machine learning framework such as TensorFlow, PyTorch, or Keras.

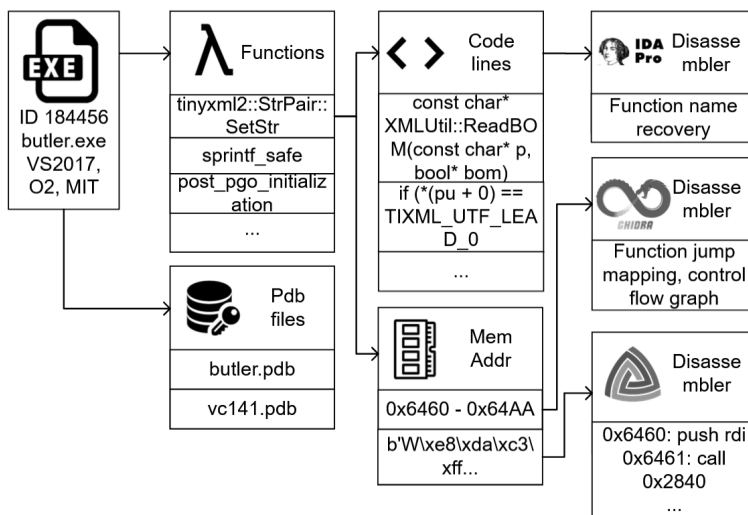

Figure 4: Dataset Database Schema

The SQLite database consists of four primary tables: `binaries`, `functions`, `rvas`, and `lines` (illustrated Figure 4). The `binaries` table retains a reference of each binary’s configuration used during compilation, e.g. platform, build mode, compiler version, and optimization, and assigns each binary an unique identifier for further reference. We also register additional information about each executable including the file name, the location of the project on GitHub, the project’s license, and the size of the binary in this table. Using the `binaries` table, researchers can curate subsets of the dataset to meet their training needs, e.g. by selecting only binaries of a certain size or with a certain license.

To provide more knowledge on functions and minimize the need to distribute pdb files (since, as we saw earlier, pdb files can take up 90+% of dataset space), the `functions`, `rvas` and `lines` tables utilize the unique identifier for each binary stored in `binaries` table to present the relationship between function level information and binaries. The `functions` tables offers a high-level overview of functions, presenting a hash of the function’s bytes and the function name, whereas the `rvas` and `lines` tables provide lower-level function details. Specifically, the `rvas` table documents the relation between each function and the its relative virtual address when the binary is loaded into memory. On the other hand, the `lines` table illustrates the mapping of each source code line to the precise byte address located in the compiled binary. The dataset also provides the relation between binaries and their corresponding pdb files in a `pdbs` table, in case researchers want to make use of those files for further binary analysis.

Figure 4 shows the information that is available about a single binary within an ASSEMBLAGE dataset. As an example, we query the database for a binary called `butler.exe`, which has the unique identifier `184456`. In the `binaries` table, we get basic facts about the executable, including the compiler version (Visual Studio 2017), build mode (Release), optimization flag (`O2`), and associated license (MIT). In the `functions` table, we can see that this binary has 568 functions; in particular, we focus on one function called `tinyxml2::StrPair::SetStr`, uniquely identified by the tag `51629995`. We use this unique identifier to query the `lines` and `rvas` tables for further information about this function. In the `lines` table, we can see the source code corresponding to this function, such as the line `if (*(pu + 0) == TIXML_UTF_LEAD_0`. From the `rvas` table, we learn that this function will be loaded into the relative addresses from `0x6460` to `0x64AA`. Thus, this example demonstrates how all the information needed to do binary analysis with corpuses of ASSEMBLAGE executables is available in the accompanying ASSEMBLAGE SQLite database.

**Limitations** It is natural to be concerned about the presence of malware in any dataset of binary executables. ASSEMBLAGE accumulates binaries by compiling source code from GitHub, which explicitly prohibits malware on its platform and allows users to report suspected malware to its community discussion board. Currently, ASSEMBLAGE does not independently verify the benignness of the binaries it collects, though we are looking to add malware scanning, following the model pioneered by EMBER (Anderson and Roth, 2018), in the next iteration of the tool.

## 5 Evaluating Assemblage on AWS

We deployed ASSEMBLAGE on AWS for easy scalability. In this section, we detail our experience running ASSEMBLAGE and generating datasets on this platform.

**Cost and Performance of Assemblage over 20 Weeks** We ran ASSEMBLAGE for over a year on AWS; here, we report on a systematic study of its cost over a 20 week period in 2023. The recipe chosen for this study, which aimed to build a diverse Windows PE binary corpus, used our crawler to identify C++ repositories (queried via language in GitHub’s API) created between January 2009 and July 2023. We gathered roughly 4 million suitable repositories, then attempted to build each of the repositories in 17 distinct configurations

via ASSEMBLAGE. While many repositories failed to build (*e.g.*, Linux repositories), we ultimately built 791,564 Windows PE binaries from 161,796 repositories.

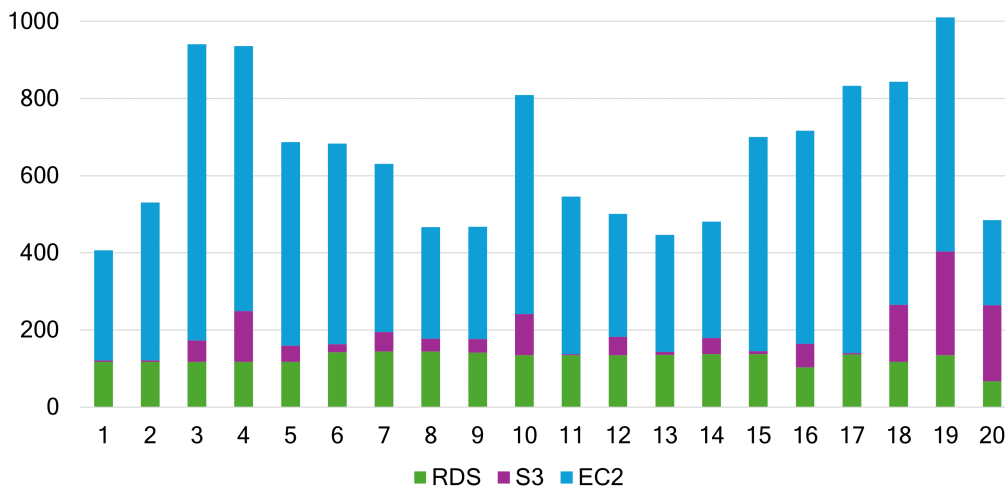

Figure 5: 20 Week Deployment Cost (USD)

Figure 5 shows the per-week cost to run ASSEMBLAGE over our 20-week period; cost details were gathered from AWS’s “Cost Explorer” panel. The total cost for generating and warehousing our corpus of 890k binaries was \$12,285. Our cluster was initialized with 16 AWS T3.large Windows instances (\$0.11 USD/hour) as builder nodes, one T3.xlarge Linux instance (\$0.17 USD/hour) running the coordinator node and crawler, and one R6g.large RDS database instance to host a MySQL database of metadata.

Costs varied over the twenty-week period as we administered the cluster flexibly to best accommodate our varying needs. After two weeks of stable builds, we gradually doubled the number of worker nodes we deployed. During week 5, we realized the system was bottlenecked both due to differing success rates among our builders and due to GitHub-imposed limitations on cloning; thus, we scaled the system down slightly. By week 10 we had exhausted all available input repositories from GitHub. In week 14, we re-queued repositories that had previously failed to clone; this restored high-speed binary collection, prompting us to expand the cluster by adding more worker nodes.

Overall, the blue bars representing the instance running cost dominates the overall cost, and the S3 cost (purple portion) remained relatively low throughout most weeks, with occasional spikes as a result of dataset exporting. The cost of the database shown in green remains relatively constant for majority of the time, as there was no change in either size or quantity of database instances.

**Evaluating Recipe Reproducibility** Repositories on GitHub are constantly updating with new commits and changes in branches. This revolving process can cause the binaries produced by compiling latest commit of source code to be different from those compiled using previous versions. Our reproducibility study measured the impact of the dynamic nature of GitHub on ASSEMBLAGE’s performance. We measured ASSEMBLAGE’s reproducibility by



reconstructing a 10k Windows PE binary dataset from one recipe three times. The collected binaries from each round were compared to evaluate consistency and reliability.

We deployed 4 `T3.large` builder nodes with 2 CPU cores (Intel Xeon Platinum 8000 series) and 8 GB of RAM, 1 `T3.xlarge` coordinator node with 4 cores (Intel Xeon Platinum 8000 series) and 16 GB RAM, and a `R6g.large` RDS database. Each evaluation on generated dataset involved running the builds simultaneously on each node, with 6 building processes for each build configuration. In consideration of bandwidth, cloning time, and relatively low possibility of the repositories being pushed with new commits in our experiment time span, we only do a shallow git clone, that is to only retrieve the latest commit without history git information. `ASSEMBLAGE` stores git commit hash and last update time of each repository in recipe, and users can use this information to clone the whole repository and revert back to the last recorded commit, to ensure the compiled source code doesn't change over new commits. To select our 10k binaries, we first used `ASSEMBLAGE` to randomly crawl and build repositories from GitHub until 10,000 binaries were successfully built; then we created a recipe at the moment and reconstructed the dataset from the same recipe three separate times.

Table 6: Reproducibility Study (Three Rounds)

Round	1	2	3
Total Task Count	10,000	10,000	10,000
Successful Task Count	10,000	10,000	10,000
Zip File Count	10,000	10,000	10,000
Binary Count	11,177	11,177	11,177
Running Time (hrs)	10.4	10.9	10.4

The results of our three-round data reproduction testing are presented in Table 6 based on the database, storage service and binary dataset. In three replication experiments, the total 10,000 tasks are all successfully built and yielded the same amount of binaries. We also inspected the binary file and source code and ensured that each binary are built from same source code and mostly identical (due to the nature of compilers, even building on same source code will yield slightly different binaries). Overall, our experiments confirmed the reproducibility and determinism of `ASSEMBLAGE` as a dataset generation tool.

## 6 Assemblage for ML: Three Case Studies

In this section, we demonstrate the utility of `ASSEMBLAGE` for a variety machine learning tasks. We use `ASSEMBLAGE` Windows datasets to evaluate three widely-regarded machine learning approaches to binary analysis problems: a LightGBM model for compiler provenance identification (Du et al., 2022), a graph neural network (GNN) for binary function similarity detection (Li et al., 2019), and a BERT-based transformer network for understanding binary files, fine-tuned on the task of binary function similarity detection (Wang et al., 2022). Our experience highlights the challenges of applying current machine learning models to Windows data, and the commonness of these challenges across model architectures and tasks. Specifically, we demonstrate that models developed on Linux data do not

perform well when applied to Windows data, signifying a lack of generalizability, and we note the prevalence of Linux-specific tool chains in the literature. Our findings reveal the importance of ASSEMBLAGE datasets, both as a tool for evaluating existing techniques and as a data source for training the next generation of machine learning models.

### 6.1 Case Study: Learning Compiler Provenance

Compiler provenance inference is a machine learning task for determining the compiler configuration used to build a binary, including compiler version, build flags, and compiler passes. We trained a state-of-the-art provenance learning model PassTell (Du et al., 2022) on a combination of data, mixing the authors’ original Linux dataset with Windows PE binaries obtained from ASSEMBLAGE. This allowed us to evaluate PassTell’s performance on a more diverse corpus, demonstrating the utility of ASSEMBLAGE in assessing binary analysis models.

We first used ASSEMBLAGE to build a dataset of Windows binaries that complemented the Linux binaries studied in the original PassTell paper. We attempted to build each of the 15 source projects selected by Du et al. (2022), but due to differences between the Linux and Windows platforms and their respective compiler infrastructures, some projects could not be rebuilt. In total, we collected 127 binaries, which we proceeded to preprocess via the same protocol as the original paper. Though the PassTell authors used objdump, a linear disassembler, to extract function bytes, we found higher success rates with IDA Pro, augmented with the PDB files collected by ASSEMBLAGE, to accurately handle the significant number (5%) of discontinuous functions present in Windows binaries. Following disassembly, we masked operands and literals in the same manner as Du et al. (2022), and balanced the training data by compiler toolchain, version, and optimization level.

We conducted two experiments using PassTell, one with mixed-platform data, and one with only Windows data. For our mixed-platform experiment, we combined the Clang and GCC binaries from the original PassTell dataset with our dataset of Windows binaries, which were built with the Microsoft Visual C++ Compiler (MSVC). We then re-trained PassTell on our mixed dataset on an Ubuntu 22.04 server equipped with an AMD EPYC 7713P@1.9Ghz 64-Core Processor and 512GB of RAM. The confusion matrix in Figure 6, which depicts the results of this experiment, displays an ambiguous diagonal pattern, reflecting the model’s recognition capacity for compiler optimizations. Individual compilers are distinguishable as square areas, indicating the model’s ability to discern among the three compilers. Note that the outline of the square formed by the MSVC compiler is much more prominent than those of the other two compilers, yet the diagonal of the confusion matrix is least pronounced in that section. This indicates that PassTell performs much worse at compiler version and optimization level identification on the Windows portion of the dataset than it does on its Linux counterpart. Additionally, when comparing our Linux results with the authors’, we observed significantly lower prediction accuracy for Clang binaries, where precision drops to around 60%. This could be because the original paper’s analysis does not cover cross-function optimizations such as the function inlining on Clang data.

To better determine how much the difference in operating systems affected PassTell’s accuracy on the mixed dataset, we conducted a second experiment using solely our Windows data. The result is shown as the confusion matrix in Figure 7. Although there is a

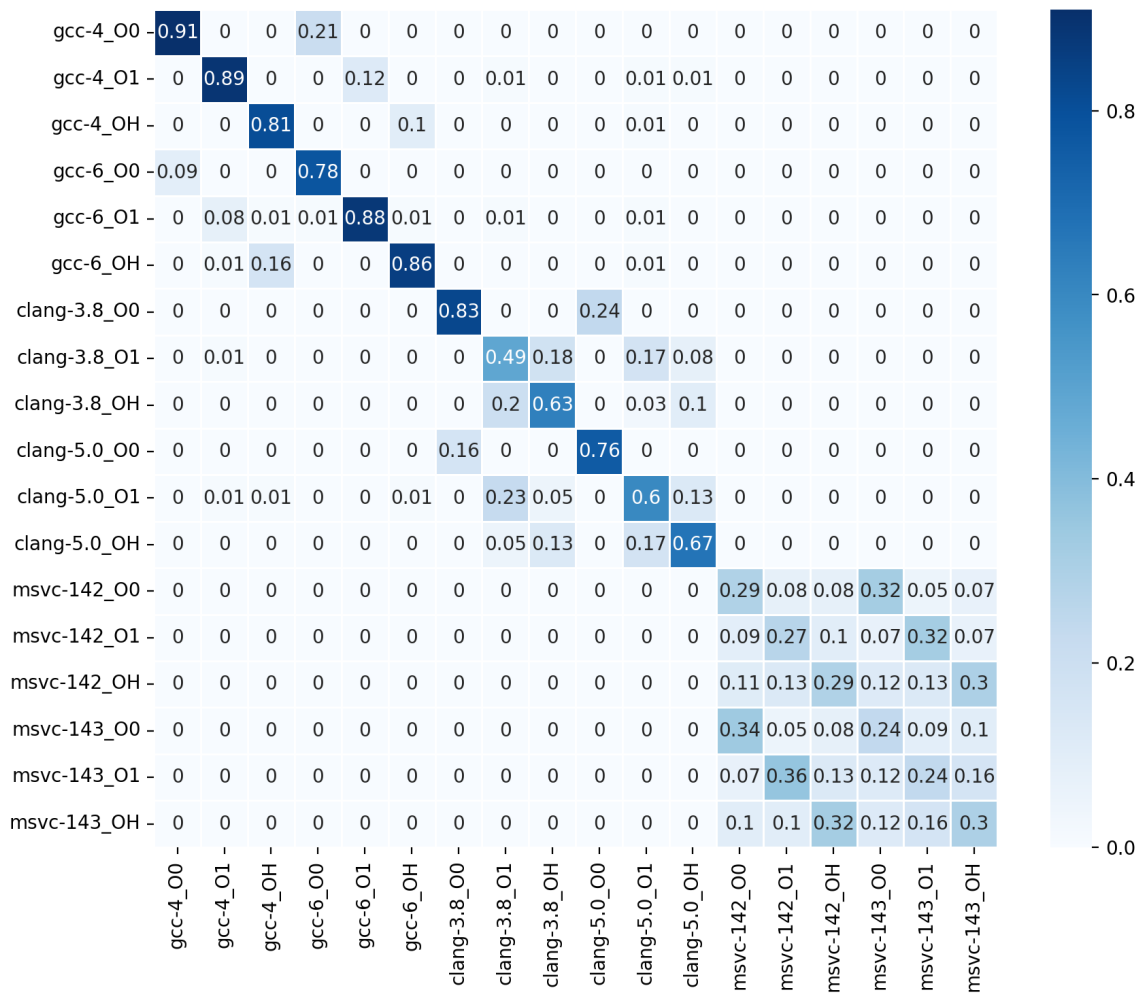

Figure 6: PassTell’s Confusion Matrix on the dataset mixing the author’s training data (top left) with ASSEMBLAGE’s Windows PE binaries (bottom right).

recognizable diagonal line, indicating that the model has the ability to tell the difference between various compiler versions and settings to some degree, the overall accuracy peaks at 0.58, lower than the accuracy on GCC and Clang that the authors claim in the paper. We conclude that the approach proposed by the PassTell authors could not effectively capture the difference between versions and optimization levels from MSVC.

The observation of PassTell’s performance on Windows data indicates the limits of training models on small binary datasets lacking diversity. While the approach put forth by Du et al. (2022) seemed promising when applied to a small Linux dataset, extending the work to Windows data from ASSEMBLAGE revealed serious shortcomings. This underscores the utility of ASSEMBLAGE as a tool for machine learning researchers in the binary analysis space.

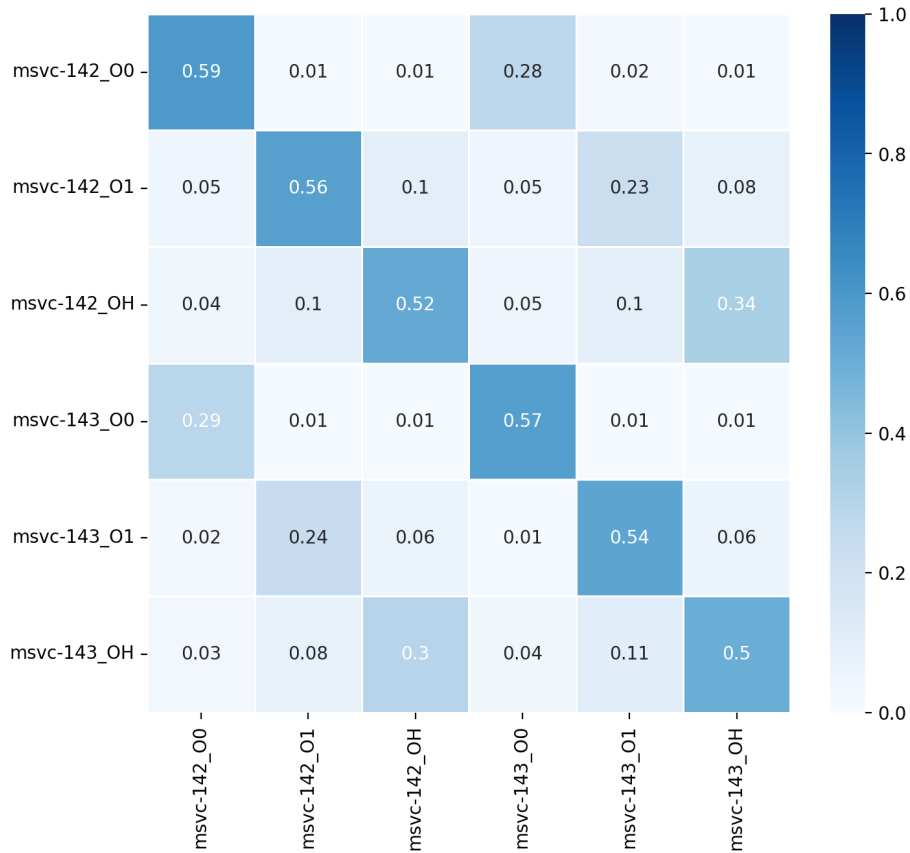

Figure 7: PassTell’s Confusion Matrix on the ASSEMBLAGE’s Windows PE Binaries.

## 6.2 Case Study: Binary Function Similarity

Next, we used ASSEMBLAGE to evaluate how well a graph neural network (GNN) trained on Linux data generalizes to Windows binaries. We conducted these experiments on the GNN developed by Li et al. (2019) for binary function similarity detection, as implemented and open-sourced by Marcelli et al. (2022).<sup>2</sup> We adhered closely to the procedures outlined in the Marcelli et al. (2022) README, making use of their scripts and notebooks to create a dataset of ASSEMBLAGE functions preprocessed according to the specifications of the model from Li et al. (2019). We made only one change to their data processing pipeline — instead of removing singleton functions, we allowed them to stay in the dataset and be part of negative pairs, as they can still provide a training signal to the model this way. By following the same data processing protocols as Marcelli et al. (2022), we ensured a fair comparison with their results.

We started with a dataset of 219,265 binaries collected by ASSEMBLAGE. After removing functions with fewer than five basic blocks and discarding duplicate functions (identified by comparing a hash of their opcodes), we were left with a final dataset of 1.78 million functions. From here, we created ground truth positive and negative pairs of functions

2. Code from [https://github.com/Cisco-Talos/binary\\_function\\_similarity/](https://github.com/Cisco-Talos/binary_function_similarity/).

Table 7: The criteria for positive pairs for each task. An X indicates that the designated variable must differ in the pair. A \* indicates that the designated variable *may* differ. If a cell is unmarked, then its corresponding variable does not differ.

	Arch	Bit	Compiler	Version	Opt
arch	X				
bit		X			
comp			X	X	
ver				X	
opt					X
XA	X	X			
XC			X	X	X
XC + XB		X	X	X	X
XM	*	*	*	*	*

on which to evaluate our model. Negative pairs consist of two different functions, whereas positive pairs consist of functions originating from the same source code, but differing in one or more of the following: architecture, bitness, compiler, compiler version, and optimization. Marcelli et al. (2022) identifies nine different evaluation tasks, separated by the nature of the positive pair (see Table 7). Because ASSEMBLAGE data is currently restricted to a single architecture and compiler, we were only able to create evaluation pairs for four of the nine tasks: bit, ver, opt, and XM. From our 1.78 million functions, we were able to create 6 positive pairs for task “bit”, 22,434 positive pairs for task “opt”, 21,031 positive pairs for task “ver”, and 298,880 positive pairs for task “XM”, which we subsampled down to 50,000 pairs. For each task, we created the same number of negative pairs as positive pairs. Because we only had 6 positive pairs for “bit”, we chose not to evaluate this task, as there wasn’t sufficient data to present a meaningful result.

Table 8: AUC scores evaluating binary function similarity model generalization between the Linux and Windows domains.

	Train Windows Test Linux	Train Linux Test Windows	Train Linux Test Linux
arch	0.50	—	0.97
bit	0.70	—	0.99
comp	0.63	—	0.80
opt	0.72	0.62	0.88
ver	0.82	0.64	0.98
XA	0.48	—	0.86
XC	0.63	—	0.86
XC+XB	0.61	—	0.87
XM	0.54	0.61	0.87

We report AUC scores for three sets of experiments. In the first experiment, we used the 1.78 million Windows functions in our ASSEMBLAGE dataset to train the GNN model published in Marcelli et al. (2022) from scratch, then tested on their original Linux test dataset. To facilitate comparison, we kept the same training settings used by authors, training the embedding model in pair mode for ten epochs with opcode features. In the second experiment, we tested the Linux pre-trained GNN model from Marcelli et al. (2022) on the Windows function pairs created from the ASSEMBLAGE dataset. Finally, the results from running the Marcelli et al. (2022) Linux-trained GNN against the Linux test set are included as a baseline. Results from all experiments are presented in Table 8.

The results in this case study reinforce our conclusions from our study of compiler provenance identification. As the scores in Table 8 make clear, the binary function similarity detection GNN from Li et al. (2019) is unable to transfer knowledge between the Linux and Windows contexts. Due to the ubiquity of Windows software, many downstream applications of binary analysis tools, including function similarity detection and provenance identification tools like the ones tested here, will be to Windows binaries. Therefore, it is essential that these tools perform well when applied to Windows files. As the experiments in this section demonstrate, this necessitates a large amount of labeled, high-quality Windows data for these tools to be developed on. ASSEMBLAGE addresses this need by providing the first robust technique for curating high-quality Windows data.

### 6.3 Case Study: Transformer-Based Learning

In addition to traditional techniques for machine learning, we also evaluated our ASSEMBLAGE dataset on some more recent transformer-based approaches for binary code similarity detection. jTrans (Wang et al., 2022) is a recently-proposed transformer method for binary code similarity. Based on the BERT paradigm (Devlin et al., 2019b), jTrans uses masked language modeling and a novel task, jump target prediction, in its pre-training phase. This is followed by fine-tuning on labeled function data using triplet loss.

The jTrans authors released their data processing scripts, and we were able to use their code to process our ASSEMBLAGE data, with one exception. To extract function byte addresses, the jTrans script exploits features specific to Linux binaries. To accommodate Windows PE binaries into processing, where this technique wouldn't apply, we instead used the function information contained in ASSEMBLAGE's SQLite database to retrieve function byte addresses. Other than that, we precisely followed the script released by the jTrans authors to create a training and validation set.

Table 9: Reproducing jTrans on our Windows and Linux datasets

Completed Epochs	1	20	50
Fine-tune & Evaluate on Windows	0.165	0.519	0.52
Fine-tune & Evaluate on Linux	0.829	0.829	0.83
Fine-tune & Evaluate on Linux (as reported in jTrans paper)	0.797	N/A	0.97

The jTrans authors did not release their pre-training code, so we were only able to conduct fine-tuning experiments on Windows and Linux data. We randomly selected 72000 Windows PE binaries and 23000 Linux ELF binaries from ASSEMBLAGE’s dataset, processed them, and separated them into training and validation sets for Windows and Linux, respectively. For both the Windows and Linux datasets, using the hyperparameter settings recommended by the jTrans authors, we ran fine-tuning for 50 epochs, at which point the MRR over the training set became stable. Then we used the withheld validation set to calculate the MRR score on 4 optimization levels; the result is shown in Table 9.

Table 9 shows a notable difference between the reported MRR scores on Linux (0.83) and Windows (0.52) data, even with fine-tuning. Pre-training dominates the model’s learning in our Linux experiments, and fine-tuning on Linux data doesn’t contribute much to the model’s performance, increasing accuracy on Linux test data by only .001 percent after fifty epochs. On the other hand, fine-tuning on Windows data raised the model’s MRR score from 0.17 to 0.52 on Windows test data. Because the authors have not released their code for pre-training, we could not conduct any further investigation into the impact of the pre-training step. However, it is significant that jTrans and jTrans-zero (jTrans without fine-tuning) both perform worse on the larger, more diverse ASSEMBLAGE data than they do on their original training corpuses. This demonstrates the value that ASSEMBLAGE brings to researchers, who can leverage its datasets to conduct experiments on more challenging and more realistic data.

## 7 Conclusion

Binary analysis is a rapidly-accelerating field whose growth is placing increasing demands on the availability of diverse, high-quality binary corpuses. Unfortunately, binary analysis has a data availability crisis: licensing challenges, file size, and lack of standardization in data set distribution continue to obfuscate the comparison of state-of-the-art work.

To help build the next generation of robust datasets of binaries, we introduced ASSEMBLAGE, a distributed system that crawls, configures, builds, and distributes richly-labeled binary corpuses in a variety of configurations. To our knowledge, ASSEMBLAGE is the largest-ever effort to build publicly-available corpuses of Windows PE binaries. ASSEMBLAGE encapsulates a wide variety of corpus construction methodologies via a “recipe,” which contains all information necessary to precisely reproduce a binary corpus. We demonstrate ASSEMBLAGE’s robustness and scalability by studying its performance over a 20-week period in 2023, producing 890k Windows PE binaries, totaling over 258M functions. Following that time, we built a Linux-based builder using GCC and Clang, and built 428k Linux ELF binaries across eight configurations.

Given the prevalence of the Windows operating system, we believe that a primary use case of machine learning tools for binary analysis will be on Windows binaries. The vast bulk of ML algorithms in this space are currently trained and evaluated solely on Linux binaries; our case studies illustrate the challenges of generalizing state-of-the-art models trained on Linux ELF binaries to work on PE binaries. For example, we observe in our measurements of Passtell that models that perform well on small GCC-based binaries may fare much worse on larger Windows PE binaries (see Figure 6); our measurements of binary function similarity paint a similar picture. We conclude that ASSEMBLAGE provides the first

large scale dataset of Windows binaries. It can easily be leveraged to train models for a variety of binary analysis tasks, and fills a critical gap in the field and enables new research directions. Along these lines, we are currently working to use our datasets to perform language modeling, leveraging the rich source-to-binary mapping available in ASSEMBLAGE to apply transformer-based language models to Windows binaries for the first time.

We present ASSEMBLAGE as a remedy to the dataset gap in binary analysis, and hope that it will facilitate reproducible infrastructure for evaluating the next generation of binary analysis tools, built on increasingly-complex models.

## References

- Sebastian Abt and Harald Baier. A Plea for Utilising Synthetic Data when Performing Machine Learning Based Cyber-Security Experiments. In *Proceedings of the 2014 Workshop on Artificial Intelligent and Security Workshop*, pages 37–45, New York, NY, USA, 2014. ACM. ISBN 978-1-4503-3153-1. doi: 10.1145/2666652.2666663. URL <http://doi.acm.org/10.1145/2666652.2666663>. Series Title: AISec '14.
- Sunwoo Ahn, Seongwan Ahn, Hyungjoon Koo, and Yunheung Paek. Practical binary code similarity detection with bert-based transferable similarity learning. In *Proceedings of the 38th Annual Computer Security Applications Conference, ACSAC '22*, page 361–374, New York, NY, USA, 2022. Association for Computing Machinery. ISBN 9781450397599. doi: 10.1145/3564625.3567975. URL <https://doi.org/10.1145/3564625.3567975>.
- Ali Al-Kaswan, Toufique Ahmed, Maliheh Izadi, Anand Ashok Sawant, Premkumar Devanbu, and Arie van Deursen. Extending source code pre-trained language models to summarise decompiled binarie. In *2023 IEEE International Conference on Software Analysis, Evolution and Reengineering (SANER)*, pages 260–271. IEEE, 2023.
- H. S. Anderson and P. Roth. EMBER: An Open Dataset for Training Static PE Malware Machine Learning Models. *ArXiv e-prints*, April 2018.
- Fiorella Artuso, Marco Mormando, Giuseppe A. Di Luna, and Leonardo Querzoni. Binbert: Binary code understanding with a fine-tunable and execution-aware transformer, 2022.
- Konstantinos Barmpis, Patrick Neubauer, Jonathan Co, Dimitris Kolovos, Nicholas Matragkas, and Richard F. Paige. Polyglot and distributed software repository mining with crossflow. In *Proceedings of the 17th International Conference on Mining Software Repositories, MSR '20*, page 374–384, New York, NY, USA, 2020. Association for Computing Machinery. ISBN 9781450375177. doi: 10.1145/3379597.3387481. URL <https://doi.org/10.1145/3379597.3387481>.
- John Boutsikas, Maksim E. Eren, Charles Varga, Edward Raff, Cynthia Matuszek, and Charles Nicholas. Evading malware classifiers via monte carlo mutant feature discovery, 2021.
- Tom Brown, Benjamin Mann, Nick Ryder, Melanie Subbiah, Jared D Kaplan, Prafulla Dhariwal, Arvind Neelakantan, Pranav Shyam, Girish Sastry, Amanda Askell, Sandhini Agarwal, Ariel Herbert-Voss, Gretchen Krueger, Tom Henighan, Rewon Child, Aditya



- Ramesh, Daniel Ziegler, Jeffrey Wu, Clemens Winter, Chris Hesse, Mark Chen, Eric Sigler, Mateusz Litwin, Scott Gray, Benjamin Chess, Jack Clark, Christopher Berner, Sam McCandlish, Alec Radford, Ilya Sutskever, and Dario Amodei. Language models are few-shot learners. In H. Larochelle, M. Ranzato, R. Hadsell, M.F. Balcan, and H. Lin, editors, *Advances in Neural Information Processing Systems*, volume 33, pages 1877–1901. Curran Associates, Inc., 2020. URL [https://proceedings.neurips.cc/paper\\_files/paper/2020/file/1457c0d6bfc4967418bfb8ac142f64a-Paper.pdf](https://proceedings.neurips.cc/paper_files/paper/2020/file/1457c0d6bfc4967418bfb8ac142f64a-Paper.pdf).
- Qibin Chen, Jeremy Lacomis, Edward J. Schwartz, Claire Le Goues, Graham Neubig, and Bogdan Vasilescu. Augmenting decompiler output with learned variable names and types. In *31st USENIX Security Symposium*, Boston, MA, August 2022. URL <https://www.usenix.org/conference/usenixsecurity22/presentation/chen-qibin>.
- Zhaoyue Chen and Yifan Sun. Accelerating Frank-Wolfe via Averaging Step Directions, May 2022. URL <http://arxiv.org/abs/2205.11794>. arXiv:2205.11794 [cs, math].
- Jacob Devlin, Ming-Wei Chang, Kenton Lee, and Kristina Toutanova. Bert: Pre-training of deep bidirectional transformers for language understanding. In *North American Chapter of the Association for Computational Linguistics*, 2019a. URL <https://api.semanticscholar.org/CorpusID:52967399>.
- Jacob Devlin, Ming-Wei Chang, Kenton Lee, and Kristina Toutanova. Bert: Pre-training of deep bidirectional transformers for language understanding, 2019b.
- Yufei Du, Kevin Snow, Fabian Monrose, et al. Automatic recovery of fine-grained compiler artifacts at the binary level. In *2022 USENIX Annual Technical Conference (USENIX ATC 22)*, pages 853–868, 2022.
- William Fleshman, Edward Raff, Richard Zak, Mark McLean, and Charles Nicholas. Static Malware Detection & Subterfuge: Quantifying the Robustness of Machine Learning and Current Anti-Virus. In *2018 13th International Conference on Malicious and Unwanted Software (MALWARE)*, pages 1–10. IEEE, October 2018. ISBN 978-1-72810-155-2. doi: 10.1109/MALWARE.2018.8659360. URL <http://arxiv.org/abs/1806.04773>. arXiv: 1806.04773.
- Georgios Gousios. The ghtorrent dataset and tool suite. In *2013 10th Working Conference on Mining Software Repositories (MSR)*, page 233–236, May 2013. doi: 10.1109/MSR.2013.6624034.
- Yeming Gu, Hui Shu, and Fan Hu. Uniasm: Binary code similarity detection without fine-tuning, 2023.
- Odd Erik Gundersen, Saeid Shamsaliei, and Richard Juul Isdahl. Do machine learning platforms provide out-of-the-box reproducibility? *Future Generation Computer Systems*, 126:34–47, January 2022. ISSN 0167-739X. doi: 10.1016/j.future.2021.06.014. URL <https://www.sciencedirect.com/science/article/pii/S0167739X21002090>.
- Salma Abdalla Hamad, Dai Hoang Tran, Quan Z. Sheng, and Wei Emma Zhang. Bertdeepware: A cross-architecture malware detection solution for iot systems. In *2021 IEEE 20th*

- International Conference on Trust, Security and Privacy in Computing and Communications (TrustCom)*, pages 927–934, 2021. doi: 10.1109/TrustCom53373.2021.00130.
- Jingxuan He, Pesho Ivanov, Petar Tsankov, Veselin Raychev, and Martin Vechev. Debin: Predicting debug information in stripped binaries. In *Proceedings of the 2018 ACM SIGSAC Conference on Computer and Communications Security*, pages 1667–1680, 2018.
- Xu He, Shu Wang, Yunlong Xing, Pengbin Feng, Haining Wang, Qi Li, Songqing Chen, and Kun Sun. Binprov: Binary code provenance identification without disassembly. In *Proceedings of the 25th International Symposium on Research in Attacks, Intrusions and Defenses, RAID '22*, page 350–363, New York, NY, USA, 2022. Association for Computing Machinery. ISBN 9781450397049. doi: 10.1145/3545948.3545956. URL <https://doi.org/10.1145/3545948.3545956>.
- Xin Jin, Kexin Pei, Jun Yeon Won, and Zhiqiang Lin. Symlm: Predicting function names in stripped binaries via context-sensitive execution-aware code embeddings. In *Proceedings of the 2022 ACM SIGSAC Conference on Computer and Communications Security, CCS '22*, page 1631–1645, New York, NY, USA, 2022. Association for Computing Machinery. doi: 10.1145/3548606.3560612. URL <https://doi.org/10.1145/3548606.3560612>.
- Robert J Joyce, Edward Raff, and Charles Nicholas. Rank-1 Similarity Matrix Decomposition For Modeling Changes in Antivirus Consensus Through Time. In *Proceedings of the Conference on Applied Machine Learning for Information Security*, 2021a. arXiv: 2201.00757v1.
- Robert J Joyce, Edward Raff, and Charles Nicholas. A Framework for Cluster and Classifier Evaluation in the Absence of Reference Labels. In *Proceedings of the 14th ACM Workshop on Artificial Intelligence and Security (AISec '21)*. Association for Computing Machinery, 2021b. doi: 10.1145/3474369.3486867. arXiv: 2109.11126v1.
- Robert J Joyce, Dev Amlani, Charles Nicholas, and Edward Raff. MOTIF: A Large Malware Reference Dataset with Ground Truth Family Labels. In *The AAAI-22 Workshop on Artificial Intelligence for Cyber Security (AICS)*, 2022. doi: 10.48550/arXiv.2111.15031. URL <https://github.com/boozallen/MOTIF>. arXiv: 2111.15031v1.
- Robert J. Joyce, Tirth Patel, Charles Nicholas, and Edward Raff. Avscan2vec: Feature learning on antivirus scan data for production-scale malware corpora. In *Proceedings of the 16th ACM Workshop on Artificial Intelligence and Security, AISec '23*, page 185–196, New York, NY, USA, 2023. Association for Computing Machinery. ISBN 9798400702600. doi: 10.1145/3605764.3623907. URL <https://doi.org/10.1145/3605764.3623907>.
- Dongkwan Kim, Eunsoo Kim, Sang Kil Cha, Sooel Son, and Yongdae Kim. Revisiting binary code similarity analysis using interpretable feature engineering and lessons learned. *IEEE Transactions on Software Engineering*, pages 1–23, 2022. doi: 10.1109/TSE.2022.3187689.
- Hyungjoon Koo, Soyeon Park, Daejin Choi, and Taesoo Kim. Semantic-aware binary code representation with bert, 2021.

- Jeremy Lacomis and Zecong Hu. Github cloner & compiler, 2020. URL <https://github.com/huzecong/ghcc>. (Accessed Aug 15, 2023).
- Jeremy Lacomis, Pengcheng Yin, Edward J. Schwartz, Miltiadis Allamanis, Claire Le Goues, Graham Neubig, and Bogdan Vasilescu. Dire: A neural approach to decompiled identifier naming. In *34th IEEE/ACM International Conference on Automated Software Engineering*, pages 628–639, San Diego, CA, 2019.
- Miles Q. Li, Benjamin C.M. Fung, Philippe Charland, and Steven H.H. Ding. I-mad: Interpretable malware detector using galaxy transformer. *Computers & Security*, 108: 102371, 2021a. ISSN 0167-4048. doi: <https://doi.org/10.1016/j.cose.2021.102371>. URL <https://www.sciencedirect.com/science/article/pii/S0167404821001954>.
- Xuezixiang Li, Qu Yu, and Heng Yin. Palmtree: Learning an assembly language model for instruction embedding. *Proceedings of the 2021 ACM SIGSAC Conference on Computer and Communications Security*, 2021b. URL <https://api.semanticscholar.org/CorpusID:232134887>.
- Yujia Li, Chenjie Gu, Thomas Dullien, Oriol Vinyals, and Pushmeet Kohli. Graph matching networks for learning the similarity of graph structured objects. In Kamalika Chaudhuri and Ruslan Salakhutdinov, editors, *Proceedings of the 36th International Conference on Machine Learning*, volume 97 of *Proceedings of Machine Learning Research*, pages 3835–3845. PMLR, 09–15 Jun 2019. URL <https://proceedings.mlr.press/v97/li19d.html>.
- Erik Linstead, Paul Rigor, Sushil Bajracharya, Cristina Lopes, and Pierre Baldi. Mining internet-scale software repositories. In J. Platt, D. Koller, Y. Singer, and S. Roweis, editors, *Advances in Neural Information Processing Systems*, volume 20. Curran Associates, Inc., 2007. URL [https://proceedings.neurips.cc/paper\\_files/paper/2007/file/a532400ed62e772b9dc0b86f46e583ff-Paper.pdf](https://proceedings.neurips.cc/paper_files/paper/2007/file/a532400ed62e772b9dc0b86f46e583ff-Paper.pdf).
- Guangming Liu, Xin Zhou, Jianmin Pang, Feng Yue, Wenfu Liu, and Junchao Wang. Codeformer: A gnn-nested transformer model for binary code similarity detection. *Electronics*, 12(7), 2023a. ISSN 2079-9292. doi: 10.3390/electronics12071722. URL <https://www.mdpi.com/2079-9292/12/7/1722>.
- Zian Liu, Chao Chen, Ahmed Ejaz, Dongxi Liu, and Jun Zhang. Automated binary analysis: A survey. In Weizhi Meng, Rongxing Lu, Geyong Min, and Jaideep Vaidya, editors, *Algorithms and Architectures for Parallel Processing*, pages 392–411, Cham, 2023b. Springer Nature Switzerland. ISBN 978-3-031-22677-9.
- Andrea Marcelli, Mariano Graziano, Xabier Ugarte-Pedrero, Yanick Fratantonio, Mohamad Mansouri, and Davide Balzarotti. How machine learning is solving the binary function similarity problem. In *31st USENIX Security Symposium (USENIX Security 22)*, pages 2099–2116, 2022.
- Microsoft. Microsoft visual studio dia2dump sample, 2022a. URL <https://learn.microsoft.com/en-us/visualstudio/debugger/debug-interface-access/dia2dump-sample?view=vs-2022>.

- Microsoft. vcpkg c/c++ dependency manager from microsoft, 2022b. URL <https://vcpkg.io/en/>.
- OpenAI. Gpt-4 technical report. *ArXiv*, abs/2303.08774, 2023. URL <https://api.semanticscholar.org/CorpusID:257532815>.
- Tirth Patel, Fred Lu, Edward Raff, Charles Nicholas, Cynthia Matuszek, and James Holt. Small effect sizes in malware detection? make harder train/test splits! In *Conference on Applied Machine Learning for Information Security (CAMLIS)*, pages 181–192, 2023. URL <https://ceur-ws.org/Vol-3652/paper12.pdf>.
- Kexin Pei, Jonas Guan, David Williams King, Junfeng Yang, and Suman Jana. Xda: Accurate, robust disassembly with transfer learning. In *Proceedings of the 2021 Network and Distributed System Security Symposium (NDSS)*, 2021.
- Edward Raff. A Step Toward Quantifying Independently Reproducible Machine Learning Research. In *NeurIPS*, 2019. URL <http://arxiv.org/abs/1909.06674>. arXiv: 1909.06674.
- Edward Raff. Research Reproducibility as a Survival Analysis. In *The Thirty-Fifth AAAI Conference on Artificial Intelligence*, 2021. URL <http://arxiv.org/abs/2012.09932>. arXiv: 2012.09932.
- Edward Raff and Charles Nicholas. A Survey of Machine Learning Methods and Challenges for Windows Malware Classification. In *NeurIPS 2020 Workshop: ML Retrospectives, Surveys & Meta-Analyses (ML-RSA)*, 2020. URL <http://arxiv.org/abs/2006.09271>. arXiv: 2006.09271.
- Edward Raff, Richard Zak, Gary Lopez Munoz, William Fleming, Hyrum S. Anderson, Bobby Filar, Charles Nicholas, and James Holt. Automatic Yara Rule Generation Using Biclustering. In *13th ACM Workshop on Artificial Intelligence and Security (AISec'20)*, 2020. doi: 10.1145/3411508.3421372. URL <http://arxiv.org/abs/2009.03779>. arXiv: 2009.03779.
- J-Michael Roberts. Virus Share, 2011. URL <https://virusshare.com/>.
- Md Omar Faruk Rokon, Risul Islam, Ahmad Darki, Evangelos E Papalexakis, and Michalis Faloutsos. SourceFinder: Finding Malware Source-Code from Publicly Available Repositories in GitHub. In *23rd International Symposium on Research in Attacks, Intrusions and Defenses (RAID 2020)*, pages 149–163, San Sebastian, October 2020. USENIX Association. ISBN 978-1-939133-18-2. URL <https://www.usenix.org/conference/raid2020/presentation/omar>.
- Aleieldin Salem, Sebastian Banescu, and Alexander Pretschner. Maat: Automatically analyzing virustotal for accurate labeling and effective malware detection. *ACM Trans. Priv. Secur.*, 24(4), jul 2021. ISSN 2471-2566. doi: 10.1145/3465361. URL <https://doi.org/10.1145/3465361>.

- Statcounter. Desktop operating system market share worldwide. <https://gs.statcounter.com/os-market-share/desktop/worldwide/>, Sept. 2023. URL <https://gs.statcounter.com/os-market-share/desktop/worldwide/>. Accessed: 2023-10-09.
- Hao Wang, Wenjie Qu, Gilad Katz, Wenyu Zhu, Zeyu Gao, Han Qiu, Jianwei Zhuge, and Chao Zhang. jtrans: jump-aware transformer for binary code similarity detection. *Proceedings of the 31st ACM SIGSOFT International Symposium on Software Testing and Analysis*, 2022. URL <https://api.semanticscholar.org/CorpusID:249062999>.
- Jason Wei, Yi Tay, Rishi Bommasani, Colin Raffel, Barret Zoph, Sebastian Borgeaud, Dani Yogatama, Maarten Bosma, Denny Zhou, Donald Metzler, Ed Huai hsin Chi, Tatsunori Hashimoto, Oriol Vinyals, Percy Liang, Jeff Dean, and William Fedus. Emergent abilities of large language models. *Trans. Mach. Learn. Res.*, 2022, 2022. URL <https://api.semanticscholar.org/CorpusID:249674500>.
- Mike Wong, Edward Raff, James Holt, and Ravi Netravali. Marvolo: Programmatic data augmentation for deep malware detection. In *Machine Learning and Knowledge Discovery in Databases: Research Track: European Conference, ECML PKDD 2023, Turin, Italy, September 18–22, 2023, Proceedings, Part I*, page 270–285, Berlin, Heidelberg, 2023. Springer-Verlag. ISBN 978-3-031-43411-2. doi: 10.1007/978-3-031-43412-9\_16. URL [https://doi.org/10.1007/978-3-031-43412-9\\_16](https://doi.org/10.1007/978-3-031-43412-9_16).
- Bolun Wu, Yuanhang Xu, and Futai Zou. Malware classification by learning semantic and structural features of control flow graphs. In *2021 IEEE 20th International Conference on Trust, Security and Privacy in Computing and Communications (TrustCom)*, pages 540–547, 2021. doi: 10.1109/TrustCom53373.2021.00084.
- Sheng Yu, Yu Qu, Xunchao Hu, and Heng Yin. DeepDi: Learning a relational graph convolutional network model on instructions for fast and accurate disassembly. In *31st USENIX Security Symposium (USENIX Security 22)*, pages 2709–2725, Boston, MA, August 2022. USENIX Association. ISBN 978-1-939133-31-1. URL <https://www.usenix.org/conference/usenixsecurity22/presentation/yu-sheng>.
- Yingchao Yu, Shuitao Gan, and Xiaojun Qin. firm vulseeker: Bert and siamese based vulnerability for embedded device firmware images. In *2021 IEEE Symposium on Computers and Communications (ISCC)*, pages 1–7, 2021. doi: 10.1109/ISCC53001.2021.9631481.
- Shuofei Zhu, Jianjun Shi, Limin Yang, Boqin Qin, Ziyi Zhang, Linhai Song, and Gang Wang. Measuring and modeling the label dynamics of online Anti-Malware engines. In *29th USENIX Security Symposium (USENIX Security 20)*, pages 2361–2378. USENIX Association, August 2020a. ISBN 978-1-939133-17-5. URL <https://www.usenix.org/conference/usenixsecurity20/presentation/zhu>.
- Shuofei Zhu, Ziyi Zhang, Limin Yang, Linhai Song, and Gang Wang. Benchmarking label dynamics of virustotal engines. In *Proceedings of the 2020 ACM SIGSAC Conference on Computer and Communications Security, CCS '20*, page 2081–2083, New York, NY, USA, 2020b. Association for Computing Machinery. ISBN 9781450370899. doi: 10.1145/3372297.3420013. URL <https://doi.org/10.1145/3372297.3420013>.

Wenyu Zhu, Hao Wang, Yuchen Zhou, Jiaming Wang, Zihan Sha, Zeyu Gao, and Chao Zhang. ktrans: Knowledge-aware transformer for binary code embedding, 2023.