

Reducing Communication Overhead in the IoT-Edge-Cloud Continuum: A Survey on Protocols and Data Reduction Strategies

Dora Kreković¹, Petar Krivić¹, Ivana Podnar Žarko¹, Mario Kušek¹, and Danh Le-Phuoc²

¹ University of Zagreb Faculty of Electrical Engineering and Computing
Unska 3, 10000 Zagreb, Croatia.

dora.krekovic@fer.hr, petar.krivic@fer.hr, ivana.podnar@fer.hr,
mario.kusek@fer.hr

² Technische Universität Berlin
Straße des 17. Juni 135, 10623 Berlin, Germany danh.lephuoc@tu-berlin.de

Abstract. The adoption of the Internet of Things (IoT) deployments has led to a sharp increase in network traffic as a vast number of IoT devices communicate with each other and IoT services through the IoT-edge-cloud continuum. This network traffic increase poses a major challenge to the global communications infrastructure since it hinders communication performance and also puts significant strain on the energy consumption of IoT devices. To address these issues, efficient and collaborative IoT solutions which enable information exchange while reducing the transmitted data and associated network traffic are crucial. This survey provides a comprehensive overview of the communication technologies and protocols as well as data reduction strategies that contribute to this goal. First, we present a comparative analysis of prevalent communication technologies in the IoT domain, highlighting their unique characteristics and exploring the potential for protocol composition and joint usage to enhance overall communication efficiency within the IoT-edge-cloud continuum. Next, we investigate various data traffic reduction techniques tailored to the IoT-edge-cloud context and evaluate their applicability and effectiveness on resource-constrained devices. Finally, we investigate the emerging concepts that have the potential to further reduce the communication overhead in the IoT-edge-cloud continuum, including cross-layer optimization strategies and Edge AI techniques for IoT data reduction. The paper offers a comprehensive roadmap for developing efficient and scalable solutions across the layers of the IoT-edge-cloud continuum that are beneficial for real-time processing to alleviate network congestion in complex IoT environments.

Keywords: IoT · Data Compression · Protocols · Device Communication · Edge.

1 Introduction

Modern Internet of Things (IoT) solutions are becoming increasingly distributed and even decentralized, operating within heterogeneous and complex computing and communication environments. Large-scale IoT deployments are composed of numerous sensors and actuators spread across diverse locations which generate vast amounts of data, creating a need for alternative architectures which move processing to the edge. This move away from centralized cloud-based IoT platforms has led to the concept of the *IoT-edge-cloud continuum*. With traditional, centralized approaches, the majority of IoT traffic is sent to cloud servers for processing and storage, resulting in network congestion and long response times. The IoT-edge-cloud continuum reverses this trend by enabling data processing as close to its source as possible – on nearby edge devices or even directly on the IoT devices themselves. This significantly reduces the overall network traffic to the cloud and reduces processing delays, leading to a more responsive and efficient IoT system for processing data and reacting to events in local smart environments hosting various IoT devices.

The IoT-edge-cloud continuum is facilitated by *edge computing*: It introduces an additional layer within the IoT architecture, positioned between IoT devices and the cloud [1]. In this setup devices can make real-time decisions with reduced latency, which is critical for applications requiring immediate action, such as industrial automation and autonomous vehicles. Additionally, pre-processing and filtering of raw IoT data at the edge reduces the amount of data transmitted within the continuum and the overall data volume sent to the cloud, thereby conserving network bandwidth. This is particularly beneficial in IoT scenarios with limited bandwidth or high data volumes. Finally, edge computing enhances security by allowing sensitive data to be processed and analyzed locally, minimizing the risk of data exposure during transmission to the cloud.

The sheer volume of data generated by IoT devices can overwhelm network resources. To avoid this, various data reduction strategies such as compression, prediction, and aggregation can be employed. The optimal combination of communication protocol and data reduction technique depends on the specific requirements of the application and the capabilities of the devices involved.

This survey paper aims to answer the following research questions:

1. Which *communication technologies and protocols* are most suitable for different aspects of the IoT-edge-cloud continuum? This includes analyzing both wireless communication technologies and application-layer protocols, considering factors such as power consumption, range, throughput, and data overhead.
2. Which *data reduction strategies* (compression, prediction, aggregation) are most effective in reducing data transmission within the continuum? The analysis considers the trade-offs between data accuracy and processing complexity.
3. How can we effectively map specific communication protocols and data reduction strategies to the different layers of the IoT-edge-cloud continuum, taking into account the limitations of resource-constrained edge devices?

IoT solutions require efficient data transmission to facilitate real-time communication and collaboration between devices and services. The primary goal of this survey is to analyze the available options to reduce the communication overhead within the IoT-edge-cloud continuum in this context. By analyzing suitable communication protocols and data reduction strategies, we aim to provide a comprehensive guide for researchers and practitioners to design efficient and scalable IoT solutions that are particularly valuable for applications requiring real-time processing and minimal network congestion in complex IoT environments.

1.1 Comparison with related surveys

Existing surveys, as summarized in Table 1, have primarily focused on either data reduction techniques or communication technologies in isolation. This survey fills this gap by providing a comprehensive analysis of both aspects: We analyze both the data reduction techniques for reducing data size before transmission, and characteristics of widespread IoT protocols and technologies so that the combination can ensure efficient data transmission in the IoT-edge-cloud continuum.

Table 1: Comparison of relevant surveys.

Work	Year	Data Reduction Techniques	Communication Technologies	IoT Context	Focused on the Edge
[2]	2020	x	✓	✓	✓
[3]	2017	x	✓	✓	x
[4]	2017	✓	x	x	x
[5]	2022	✓	x	✓	✓
[6]	2023	x	✓	✓	x
[7]	2023	✓	✓	✓	x
[8]	2023	✓	✓	✓	x

Several surveys explore data transmission within specific IoT application domains. For instance, [2] investigates how edge computing can accelerate the development of smart cities and provides an overview of relevant literature to propose a taxonomy categorizing edge computing applications in this context. Similarly, [3] focuses on the technological solutions for IoT in agro-industrial and environmental sectors, explaining the underlying infrastructure and technologies.

Other surveys analyze data reduction within a broader big data context. In [4], the authors looked at the workflow of data preprocessing in the context

of big data. They provided insights into the four phases of data pre-processing, including cleansing, integration, reduction and transformation.

Some surveys, e.g. [6], emphasize the aspect of communication technologies in the IoT. In this work, the authors deal with the basics of IoT architecture and give an overview of the communication protocols developed specifically for IoT solutions. The authors also analyze security threats and general implementation challenges.

In [5], a comprehensive overview of the data reduction techniques applicable at the edge is presented. The review covered the literature on data reduction solutions at the edge of IoT systems. Algorithms, hardware technologies, the data types used and the objects that contribute to data reduction were analyzed and discussed.

Some of the studies presented here focus on a particular method or reduction technique and provide a detailed overview of that particular topic. For instance, the authors in [7] focus exclusively on the use of data compression as a technique for reducing data traffic specifically in Wireless Body Sensor Networks (WBSN). Further, authors in [8] presented an in-depth survey of data aggregation protocols based on their ability to address issues related to topology, interference, fault-tolerance, security and mobility.

While all the referenced surveys exhibit depth and comprehensiveness, our main contribution lies in examining jointly data reduction strategies and communication protocols within the scope of the IoT-edge-cloud continuum.

1.2 Our contribution

Traditional approaches to IoT communication can lead to 1) significant degradation of communication performance due to high data volumes which can overwhelm network resources, causing congestion and delays in data transmission and 2) increased energy consumption of IoT devices due to frequent data transmissions. This survey addresses these challenges by focusing on efficient and collaborative communication in the IoT-edge-cloud continuum by investigating jointly the available methods for reducing the data generated by IoT devices and communication protocols contributing to reduced network traffic.

Our contribution can be summarized as follows:

- We provide a detailed comparison of prevalent communication technologies in the IoT domain. This analysis goes beyond simply identifying their characteristics. We investigate how the combined use of protocols at different layers of the IoT-edge-cloud continuum can enhance the overall communication efficiency.
- We explore various techniques for data reduction and in combination with communication technologies to critically evaluate their applicability within the context of the IoT-edge-cloud continuum.
- We investigate the emerging concepts that have the potential to further reduce the communication overhead in the IoT-edge-cloud Continuum, including cross-layer optimization strategies and Edge AI techniques.

By providing a combined analysis of communication protocols, data reduction techniques, and emerging concepts, this survey provides a comprehensive understanding of methods for reducing communication overhead in the evolving IoT-edge-cloud continuum leading to the design of more scalable and energy-efficient IoT systems in complex environments.

The paper is structured as follows: In Section 2, we provide an overview of prevalent wireless communication technologies and application layer protocols commonly used in the IoT-edge-cloud continuum. Additionally, we compare the efficiency of these communication protocols to identify their suitability for modern IoT use cases. In Section 3, we explore various data reduction strategies, discussing their advantages and disadvantages, identify their placement within the continuum, and discuss their usage in combination with appropriate communication technology. We also conduct a comparative analysis of data reduction strategies. Section 4 addresses the emerging concepts and open challenges concerning data traffic reduction strategies in complex IoT environments. Finally, Section 5 concludes the paper, summarizing key research observations and outlining future research directions.

2 Communication technologies for the IoT-edge-cloud continuum

An IoT environment typically utilizes a hierarchical three-layered general architecture depicted in Figure 1 consisting of the device layer, edge layer and cloud layer forming the IoT-edge-cloud continuum. Data generated at the device layer is forwarded upwards to the cloud, either directly or through edge devices. Conversely, actuation commands and processed data flow from the cloud back to devices. This data transmission across layers relies on various wireless communication technologies and application-layer protocols, chosen based on the characteristics of the devices and services running within the environment. The heterogeneity of IoT environments is evident in diverse IoT devices employed at the bottom layer, ranging from wearables and agricultural sensors to robots and autonomous vehicles as well as computing nodes with different capabilities positioned at the edge layer, ranging from, e.g., RPi and Jetson Nano/Orin to a local micro-cloud with a few server racks.

IoT devices fall into three categories of constrained devices (Class 0, 1 and 2) specified in RFC 7228 [9]. Nodes in Class 0 are severely constrained (8-bit or 16-bit microcontrollers, $\ll 10KB$ of RAM, $\ll 100KB$ of Flash, battery powered) and typically use a constrained communication protocol (Low-Power Wide-Area, LPWA) for data transmission to gateways, since they do not have sufficient resources to run the complete IP stack. The gateways act as edge nodes and translate the received data into a format compatible with the chosen application-layer protocol before forwarding it to the cloud. The selection of this application-layer protocol depends on factors such as requirements of a specific use case, resources available at the gateway, and the cloud service receiving the data.

For devices communicating directly with an IoT platform in the cloud, RFC 7228 categorizes them as Class 1 or Class 2 nodes [9]). Class 2 nodes have more resources ($> 50KB$ of RAM, $> 250KB$ of Flash) and can run full implementations of the IP stack, enabling direct connection to the cloud and edge nodes at the expense of higher energy consumption. Class 1 devices offer a middle ground. Possessing more resources than Class 0 (approximately 10KB RAM and 100KB Flash), they cannot employ a full IP stack but leverage constrained application protocols like CoAP to interact with the cloud and edge nodes without requiring a gateway.

The IoT-edge-cloud continuum incorporates additional classes of devices within the edge layer, which is further divided into the far edge and near edge environment (Figure 1). Notably, edge nodes within the category of far edge (FE) nodes can also be classified as Class 2 devices, while edge nodes within the category of near edge (NE) nodes possess even greater processing power than FE nodes. These devices, both FE and NE nodes, often operate under the following constraints:

- **Limited processing power:** Edge devices typically have less processing capability than cloud servers, restricting the complexity of tasks they can handle at the edge.
- **Constrained memory:** Data storage capacity on edge devices is often limited, requiring careful consideration of data processing and storage strategies.
- **Limited energy source:** Battery life is critical for many FE devices and need to apply communication protocols that minimize energy consumption.
- **Network diversity:** Edge devices can utilize various communication modules. Some support LPWA protocols ideal for transmitting small data packets over long distances in IoT environments. Others connect via WiFi, offering higher bandwidth but with shorter range and higher power consumption.

In this complex environment diverse use cases are deployed enabling, for example, continuous environmental monitoring or human well-being tracking, or efficient interaction between autonomous vehicles and the surrounding infrastructure. Due to different requirements of such diverse use cases, various communication technologies and protocols are defined for efficient data transmission. Furthermore, selected protocols need to be in line with the specific hardware employed within each layer of the three-tiered architecture. When selecting a communication technology for data transmission between constrained devices and their first-hop neighbors, factors such as *communication range*, *frequency band*, *delay*, *energy consumption*, *battery life*, and *sleep mode configuration* must be considered. The choice of application layer protocol is more dependent on the communication architecture within a specific use case while enabling efficient data transfer from the device or edge layer towards the cloud layer.

The application-layer protocols commonly used in IoT environments often introduce overhead by adding fixed-size headers to each transmitted packet. This can be particularly detrimental in scenarios involving frequent transmissions of small amounts of data (e.g. a few sensor readings), a common occurrence in IoT communication. Therefore, a thorough analysis of the specific use case is

crucial for selecting an optimal application-layer protocol that efficiently utilizes available data buffers within each packet, minimizing overhead while effectively transmitting data.

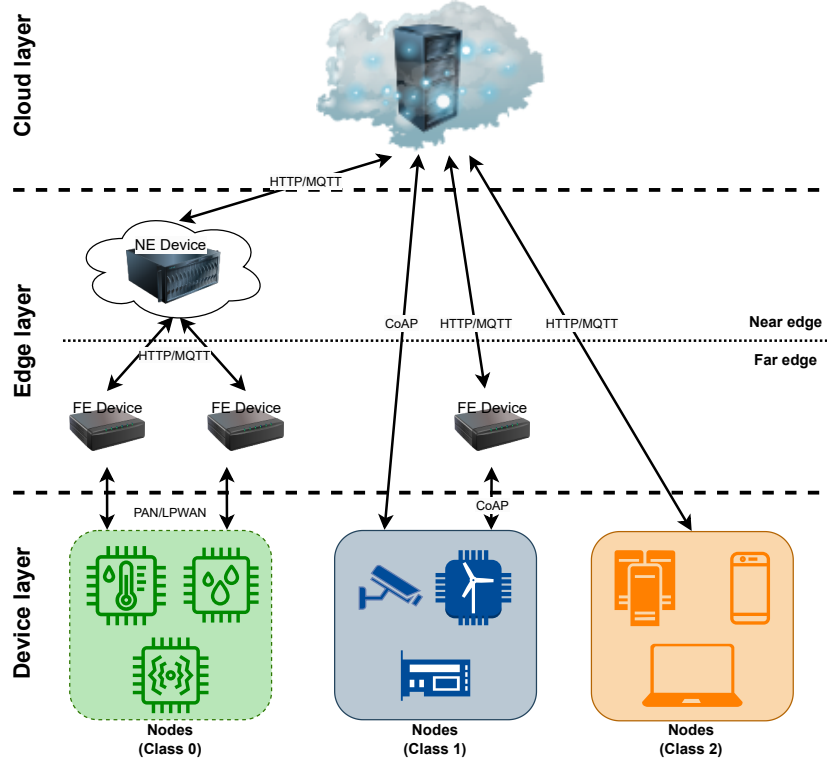

Fig. 1: Layered architecture of the IoT stack with edge computing layer.

2.1 Currently prevalent wireless communication technologies for IoT

In existing IoT setups, different wireless communication technologies are utilized to connect end devices with gateway nodes connected to the Internet. These technologies were mostly determined based on range, bandwidth, coverage, power consumption, reliability, latency and cost-effectiveness required within a specific use case [10]. In the design phase of each IoT solution, it is necessary to conduct a detailed analysis of the specific IoT use case and properly prioritize the aforementioned features to choose an optimal communication protocol for the particular scenario. In continuation, we briefly introduce technologies that are the most common choice across the existing IoT scenarios:

BLE is a Wireless Personal Area Network (WPAN) technology originally designed for short-range communication with smart IoT sensors and devices with limited power consumption [11]. Today, it is the most widespread WPAN protocol in IoT, as it is supported by computing devices such as mobile phones and laptops as well as various peripherals. The main advantage of BLE compared to its counterparts is that it is more energy-conservative than WiFi and ZigBee, which are usually considered together due to their similarities.

ZigBee is a WPAN protocol mainly used in smart home applications [12]. Its main advantage is lower power consumption, as it was originally developed to support low-cost and low-power connectivity for devices that require battery life of several months to several years, but do not require data transfer rates as high as those enabled by Bluetooth [13]. Although BLE has significantly reduced the power consumption of Bluetooth to an even lower level than ZigBee [14] and its lower data rate due to the use of the 802.15.4 standard, ZigBee remains a common choice for IoT use cases. The reason for this is that most IoT applications do not require a high data rate, and ZigBee still offers a longer range than BLE.

WiFi is a wireless communication protocol utilized to link devices in range together and to connect them to the Internet through the wireless router. As it was not originally designed for IoT use cases, but to connect conventional devices such as laptops, smartphones, and servers, some of its key aspects should be revised in order to make it suitable for dense IoT environments [15]. Its advantage compared to its main counterparts in terms of IoT setups - BLE and ZigBee - is that it offers a considerably higher data rate and a direct connection to the Internet, while its main disadvantage is its high power consumption.

LoRaWAN is a LPWAN technology that connects IoT devices over a broader area, making it more suitable for e.g. smart agriculture use cases. It offers the possibility for private network deployments and easy integration with a number of worldwide network platforms. For these reasons and its open access specifications, LoRaWAN drew the research community's attention since its first appearance in the market [16]. It implies a star topology architecture, where end devices send messages to a LoRaWAN gateway, which encapsulates the received messages in UDP/IP packets and forwards them to the network server, while communication of commands towards the end devices is transmitted in the opposite direction. Its downside compared to similar communication technologies is its low data rate and lower reliability. However, since it operates in an unlicensed spectrum, LoRaWAN offers the opportunity to set up a simple private wide area network that covers a range of up to 20 km, which makes it a popular choice for research projects and startup phases of IoT use cases, where the reliability is not critical, and the scale of a solution is not too big to manage it without third-party telecom companies.

NB-IoT is the leading LPWAN communication technology operating in a licensed spectrum and consequently offers advantages compared to LoRaWAN

in terms of data rate, latency, reliability, and range at the cost of specific benefits that LoRa offers by operating in an unlicensed spectrum - battery lifetime, capacity, and cost [17]. It was developed by 3GPP, and provides access to network services using a physical layer optimized for very low power consumption and low cost [18]. NB-IoT devices are attached to base stations, but the technology does not support authentication and certificate transfer while moving between various cells, so devices are required to choose base stations manually [19]. This is because the devices use power saving mode (PSM), where they can turn off their radio components but remain registered to a LTE network, which consequently prevents handovers and, therefore, also the mobility of connected devices [20]. Nevertheless, NB-IoT is a viable choice for use cases requiring the abovementioned benefits, especially in dense urban environments where LoRa performance deteriorates significantly.

Cellular communication technologies imply 2G/3G, 4G, and 5G mobile networks that were not primarily intended for IoT use cases. However, the 5G cellular network was not intended just to evolve mobile broadband, but to be a key IoT enabler for three main groups of use cases: enhanced mobile broadband (eMBB), massive machine-type communications (mMTC), and ultra-reliable low-latency communications (URLLC) [21]. To support such use cases, the KPI targets for the 5G network were demanding in terms of peak data rate, spectral efficiency, latency, reliability, energy efficiency, connection density, and mobility. Hence, cellular technologies are more robust and offer better performance on most of the considered attributes compared to the previously mentioned technologies, with the exception of cost and energy efficiency, which are significant factors for most IoT use cases. However, as eMBB and URLLC use cases in IoT prevail over the currently most popular mMTC group, 5G could become an important technology to support IoT use cases for reliable and efficient communication with minimal latency.

Table 2: Comparison of currently prevalent communication technologies in IoT.

	Range	Power	Data rate
BLE	< 100 m [22]	1	< 1-2 Mbps
ZigBee	indoor: 25 m, outdoor: 60 m [23]	4	< 250 Kbps
WiFi	indoor: <15 m, outdoor: <450 m [24]	5	< 2.4 Gbps
LoRaWAN	urban: 2-5 km, suburban: 15 km [25]	2	< 50 Kbps
NB-IoT	within the range of a base station	3	< 250 Kbps
Cellular	within the range of a base station	6	< 1 Gbps

In Table 2, we compare the described protocols on the attributes that solution architects should consider during the design phase in a particular IoT setup: range, power consumption and data rate. Range is an attribute that depends on many factors, such as barriers between communicating devices, interference,

module manufacturers, etc. Thus, the values for the same protocol differ across the literature, but the ratio between the compared technologies remains exact [22,23,24,25]. It confirms that BLE, ZigBee and WiFi are WPAN protocols with a shorter range than LPWAN technologies LoRaWAN and NB-IoT.

Power consumption is a parameter that cannot be specified precisely and thus we use categories (1 as the lowest to 6 as the highest) to characterize protocols since the ratio between the compared technologies across the literature is consistent [26,27,28,29,30]. In Table 2, we rated the considered communication technologies from one for BLE, which is the most energy-efficient, to six for cellular communication, which consumes the most energy. From the reported values, it is clear that BLE, ZigBee, LoRaWAN and NB-IoT are protocols primarily designed for constrained IoT devices since they consume significantly less energy than WiFi and cellular communication that are primarily used by devices with a steady energy supply.

Data rate is a significant parameter because it determines the speed of data transfer between devices utilizing a specific communication protocol. The values reported in Table 2 are reported across the literature and imply the maximum expected uplink data rate, which is rarely achieved in practice [31,32,33,17]. However, the values clearly outline that WiFi and cellular communication offer significantly higher data rates than other considered protocols, which is one of the reasons for their higher energy consumption. BLE offers a slightly lower data rate than the previously mentioned WiFi and cellular technologies, but it still has the advantage compared to the remaining protocols specifically designed for IoT - ZigBee, LoRaWAN and NB-IoT. BLE can be used for connecting computer peripherals that require higher data rates than the IoT data sent from the sensors, which usually come in small packets that ZigBee, LoRaWAN and NB-IoT can also support.

In the context of data traffic reduction, the main motivation is to reduce the overall data traffic through the global Internet, while strategies for network traffic reduction over WPAN and LPWAN communication technologies are not that critical, but should also not be neglected since by reducing the number of transmissions on a data-link layer, efficiency of sensor devices increases. Hence, the most energy-efficient wireless communication technology that offers a data rate and range required by a specific use case is the best choice for establishing a connection between IoT devices and the gateway. Further data reduction of the Internet traffic is then based on different strategies that can be applied at the gateway and edge level in line with the used application layer protocols which we analyze in the following subsection.

2.2 Application layer protocols in IoT

A comprehensive overview of application layer protocols for IoT environments and their recent advances is presented in [34]. However, not all presented protocols (e.g. XMPP and WebSocket) are equally suitable for an IoT environment. Thus, we only consider the protocols that are today the most common choice in

IoT deployments. Application-layer protocols can be classified as either request-response or publish-subscribe protocols, depending on the communication model used. We briefly introduce two of the most common options for each group. Protocols implementing the request-response communication model include HTTP (*Hypertext Transfer Protocol*) and CoAP (*Constrained Application Protocol*), while protocols implementing the publish-subscribe model include MQTT (*Message Queue Telemetry Transport*) and AMQP (*Advanced Message Queuing Protocol*). A comparison of these protocols is presented 3: In addition to the communication model, we compare them based on the category of constrained device on which the protocol can be applied and based on the header overhead. CoAP and MQTT are clearly a better choice compared to HTTP and AMQP due to their lower packet overhead. CoAP is particularly advantageous for devices with limited resources (Class 1) that cannot implement a full IP stack.

Table 3: Comparison of the most utilized application layer protocols in IoT.

	Communication model	Device type	Min. header overhead
HTTP	Request-response	Class 2	8 bytes
CoAP	Request-response	Class 1	4 bytes
MQTT	Publish-subscribe	Class 2	2 bytes
AMQP	Publish-subscribe	Class 2	8 bytes

Request-response protocols **HTTP** was initially designed for web-based communication. It runs over a TCP (*Transmission Control Protocol*) connection, offering reliable communication but with a more significant message overhead. Compared to other application layer protocols which are also based on TCP, HTTP is the most verbose and heavyweight because of the largest overhead to TCP packets and overall message size [35]. Therefore, HTTP requires a large bandwidth, consequentially increasing processing latency and energy consumption, making it a less convenient solution for IoT environments.

CoAP is a communication protocol tailored for constrained devices. It implements the request-response communication model similar to HTTP, but also supports the publish-subscribe communication model. Compared to HTTP, the main difference is that CoAP utilizes UDP protocol instead of TCP at the transport layer. This significantly reduces the communication overhead, but it makes communication less reliable [35]. Thus, in [36], the authors concluded that its downsides include bad packet delivery and inability to support complex data types. However, communication with CoAP can be performed using either the non-confirmable or confirmable messages: the later is recommended when increased reliability is required. CoAP performance depends on the network status, and it deteriorates in case of network congestion, leading to retransmission, increased energy consumption, higher latency, packet loss, and reduced throughput. These drawbacks are targeted with new extensions of CoAP, mostly based

on different Retransmission Timeout (RTO) strategies that focus on minimizing the number of retransmissions [34]. All these characteristics make CoAP the most suitable option for constrained devices in IoT environments when the request-response communication model is required.

Publish-subscribe protocols **MQTT** is a lightweight publish-subscribe protocol commonly used in various distributed systems, including IoT solutions. Its basic version runs over TCP connections, but there is also a specialized version for sensor networks named MQTT-SN, which is adapted for constrained sensor devices to run on top of UDP and to utilize reduced payload sizes [34]. The protocol architecture includes a simple broker that receives published messages and forwards them to the connected subscribers. The broker also buffers the messages for further subscribers and offers three different levels of QoS (*at most once*, *at least once*, and *exactly once*), which determine the importance of message delivery, but at the cost of sending additional control messages. The authors in [37] state that the advantage of MQTT is its lightweight implementation and energy efficiency, while the main disadvantage is that secured MQTT messages over TLS significantly increase the overhead, while secure communication without TLS is not possible. Due to the low security, there are a number of approaches to achieve a sufficient security level which is also efficient. However, due to its lightweight architecture, energy efficiency and low latency [38], it is probably the most commonly used protocol in IoT implementations today.

AMQP is a more advanced protocol than MQTT, offering higher reliability and improved security [39]. The difference to MQTT is that the messages are not routed directly from broker topics to consumers. An AMQP broker consists of *Exchanges* and *Queues* that are connected through bindings. There are several types of *Exchanges* which determine broker behavior, while a binding is associated to a routing key which filters out messages for specific queues. Finally, each *Queue* should have one consumer since the messages are lost after they are consumed from it. Due to these characteristics, AMQP has a larger header size fixed to 8 bytes, compared to the MQTT header of 2 bytes. When comparing the performance with the MQTT protocol, the authors in [40] state that AMQP offers a higher throughput, but at the cost of a larger packet size and packet loss rate. In [41], the authors state that both protocols achieve similar results when comparing latency and CPU load, although MQTT is slightly more lightweight.

2.3 Efficient composition of IoT communication technologies and protocols

Since there are many technologies and protocols for IoT environments, each with their specific advantages and disadvantages, solution architects have to consider a large number of factors to select the optimal stack of technologies and standards for a given use case. Connecting remote devices to the next layer of the IoT stack is the first step in ensuring efficient data transmission from a physical environment to the gateway nodes. The choice of the right communication technology depends on many factors where the benefits should be weighed against

each other. In addition, there are limiting factors that determine whether a particular technology can support a particular use case at all. These include, above all, range and throughput, which are usually the starting point for the right choice of communication technology in IoT. Figure 2 shows the gradation of the described technologies in terms of range and energy consumption, while they are classified into three groups based on their throughput (low, medium and high). In a simple scenario, a solution architect should choose the most energy-efficient technology with sufficient range and throughput for the expected environment and data. In reality, these scenarios can have different priorities that can alter this best practice process of choosing a suitable communication technology. In such cases, a balance must be struck between priority requirements and use case-specific factors.

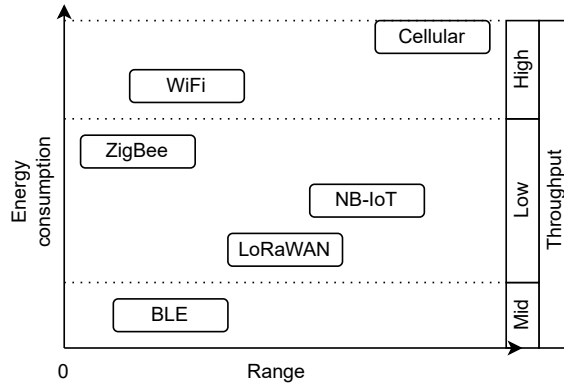

Fig. 2: Comparison of the described communication technologies.

After IoT data reaches a gateway from an end device, it is transmitted to the cloud data centers for further processing or directly towards specific end users. In both cases, it is necessary to ensure a communication architecture that will efficiently deliver the data from the network entry point towards the final destinations. As previously described, there are numerous application layer protocols based on the two major communication models, the publish-subscribe or request-response model. The first decision is to decide which of these two models is more suitable for a specific use case (Figure 3).

There are no best practices for such a decision: The publish-subscribe model offers an efficient architecture that can deliver the data from one publisher to all interested parties without connecting them directly. This loosely coupled setup is beneficial for the IoT-edge-cloud continuum since participating devices can dynamically enter or leave such architecture without affecting the rest of the system. Thus, the publish-subscribe model has the advantage in scenarios where scalability and flexibility are the primary goals. Also, in cases where one-to-many

communication is required, while the data does not need to be processed before the delivery to its receivers, it is more advisable to choose the publish-subscribe model.

The request-response model implies a tightly coupled communication, where the data is delivered to a client on request. This type of communication can ensure lower latency because it requires a direct connection between the sender and the receiver. Since IoT devices do not usually communicate directly but through an entity such as IoT platform, it is not recommended to utilize the request-response model for their direct communication. However, for communication from gateway and edge nodes with an IoT platform, or also between FE and NE devices where the data is processed or stored, this model is a more suitable choice.

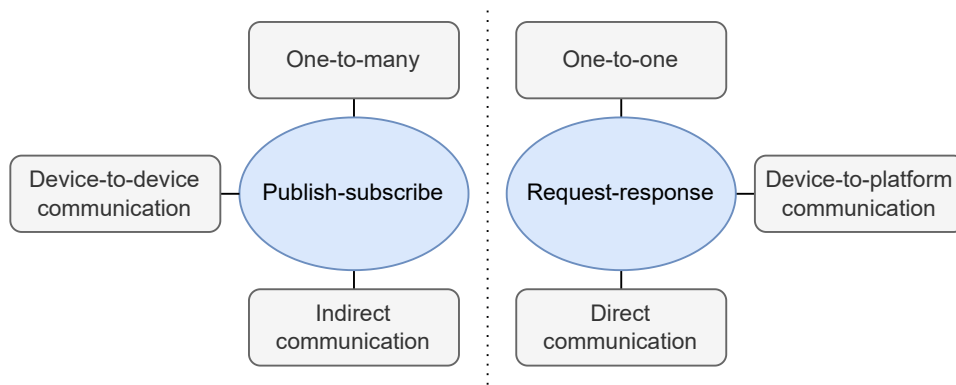

Fig. 3: Comparison of the publish-subscribe and request-response communication model for IoT.

After selecting a suitable communication model for the application layer, the solution architect must select a suitable protocol for the application layer. In the case of the request-response model, CoAP is currently more suitable than the HTTP protocol due to its aforementioned advantages. Nevertheless, the HTTP protocol is also widely used, although creates significant overhead compared to the CoAP protocol. However, HTTP offers a high degree of interoperability with other web-based systems, as it is the most commonly used protocol for communication over the Internet. In the case of the publish-subscribe model, the choice is limited to MQTT and AMQP. MQTT is widely used because it is simple and lightweight for broadcast communication, but AMQP might be a better choice when higher delivery control and throughput is required.

If the only requirement of an IoT solution is to minimize data traffic within an IP network, the choice should be limited to CoAP and MQTT. CoAP is optimized for constrained devices and its lightweight design ensures minimal protocol overhead, making it the best choice for direct communication with

less traffic. However, for more dynamic and scalable environments, MQTT is a more efficient option which ensures reliable publish-subscribe communication with minimal overhead.

After selecting the appropriate communication technologies for a particular use case, further reduction of network traffic in the IoT-edge-cloud continuum depends on the type of data generated and transmitted in a particular environment and the frequency of message transmission. Therefore, for further discussion on network traffic reduction in the continuum, we must consider the available data reduction strategies which can be used in addition to the available communication protocols and technologies.

3 Data reduction strategies for the IoT-edge-cloud continuum

Most IoT applications are characterized by a substantial volume of data produced by connected devices, which is largely due to the historical disregard of data transmission efficiency by the majority of existing solution. However, as IoT adoption continues to grow, the demand for more efficient data transmission is also increasing, as the volume of data generated is doubling annually, according to research presented in [42]. In this section, we first examine the existing data reduction strategies that can help reduce data traffic sent through communication channels in IoT deployments. They can be grouped into three basic categories:

1. Data Compression (DC),
2. Data Prediction (DP) and
3. Data Aggregation (DA).

All of these categories aim to reduce traffic to a destination node, but they employ distinct underlying principles. The *data compression* approach involves encoding the information at the nodes that generate the data and subsequently decoding it at the destination node. This category can be further divided into two primary subcategories: *lossy* and *lossless compression*. In addition, reduction can also be achieved by *data aggregation*, e.g. by transmitting average values instead of raw values at intermediate edge nodes between a data source and its destination, thereby reducing the amount of data transmitted over the network. *Data prediction* involves creating an abstraction of the sensory phenomenon, which is essentially a model that describes the generated data. This model is able to predict the values captured by the sensor nodes within a certain acceptable level of error. As the model is applied to a destination node, it reduces the need to send sensor data from the source is reduced, provided that the prediction accuracy is satisfactory. Consequently, data prediction significantly reduces the need for inter-node communication, leading to savings in energy and alleviating the network load associated with communication.

3.1 Data compression

Data compression (DC) methods are a general research problem, but in the context of this paper, the focus is on the specific application of DC in IoT environments and omit the operating principles of each compression method. DC is defined as the process of representing a piece of content while reducing the amount of data required to represent it. In the IoT context, the mechanisms of DC reduce the size of information to be transmitted or stored, thereby reducing resource consumption to meet the requirements of communication and storage infrastructure [7]. Several variants for DC methods have been proposed [43] which can be classified as:

- static or dynamic (depending on the variability of the code words over time);
- symmetric or asymmetric (referring to the relationship between compression and decompression execution times);
- semantic-dependent or entropy-based (referring to whether the data semantics is exploited or not for better compression);
- variable or fixed-rate (referring to data encoding rate);
- lossless or lossy (referring to the decompression results).

DC techniques require two processes: compression and decompression. Lossless algorithms are those that can reconstruct the signal into one that is identical to the original. In contrast, lossy algorithms allow the reconstruction of only an approximation of the original signal [44] to represent the signal with fewer samples than lossless algorithms. In lossy approaches, sensor measurements are usually represented by eliminating redundant samples or by representing them in a compressed form, assuming that redundant samples would not provide additional information for the application [45]. These methods provide irreversible compression, as it is impossible to recover the original data after their execution, and they usually have a lower computational complexity and higher compression results than lossless methods.

The focus of this overview is on lossless or lossy classification because sampled IoT sensor data is often used to represent variable signals. Thus, it is crucial to analyze the resulting signal after the compression and decompression steps of DC methods, as it is later used for analysis (e.g., for machine learning, ML) or decision-making (e.g., to trigger alarms or control actuators) in various systems. The most important differences between lossless and lossy DC techniques are outlined in Table 4.

Lossless compression Lossless compression refers to methods where no data is sacrificed during the compression process. These techniques condense data into a smaller file by employing internal shorthand to signify redundant information. In the IoT context, lossless compression encompasses a range of algorithms and strategies, including Run-Length Encoding (RLE), Huffman coding, Lempel-Ziv-Welch (LZW) compression, as well as mathematical and statistical approaches. These methods serve to remove redundancy within the data, such as recurring

Table 4: Comparison of lossy and lossless compression.

Key	Lossy compression	Lossless compression
<i>Efficiency</i>	More efficient in data size reduction.	Provides moderate data size reduction while preserving data integrity.
<i>Use Cases</i>	Suitable for applications with acceptable data loss (e.g., streaming media).	Ideal for situations where data integrity is critical (e.g., archiving).
<i>Compression Ratios</i>	Achieves higher compression ratios, resulting in smaller file sizes.	Provides lower compression ratios compared to lossy compression
<i>Reversibility</i>	Irreversible; original data cannot be fully recovered.	Reversible; allows complete restoration of the original data
<i>Encoding Complexity</i>	Computationally less complex.	May involve more complex encoding processes.
<i>Quality Loss</i>	Degrades the quality of the compressed data due to information loss.	Maintains the original data quality without degradation.
<i>Size</i>	Drastically reduces data size.	Reduces data size, though to a slightly lesser extent than lossy compression.
<i>Decompression Speed</i>	Generally has faster decompression speeds.	Slightly slower decompression speeds due to more intricate encoding.
<i>Sensitivity to Data Types</i>	Can be sensitive to the type of data, leading to variations in quality.	Less sensitive to data types, ensuring data fidelity.
<i>Space vs. Fidelity Trade-off</i>	Prioritizes space savings at the cost of fidelity.	Balances space and data integrity, suitable for long-term storage.

values or patterns, enabling DC while retaining the capability to fully restore the original data when necessary.

In a study of compression algorithms [46], two key aspects were examined: compression efficiency and resource use on embedded devices, which is a significant factor for IoT. Adaptive algorithms outperformed static ones, especially on unreliable communication channels, showing the potential for significantly increasing data transmission capacity with minimal time and power consumption. Furthermore, a Two-Tier Data Reduction (TTDR) approach presented in [47] showcased that utilizing DC through temporal data correlation at sensor nodes can reduce transmitted datasets by 62% and lower the device’s power use. In addition, temporal data correlation enabled Sprintz et al. [48] to achieve high compression with minimal memory and latency overhead for low-power IoT devices, while the authors in [49] achieved energy savings dealing with temporally correlated data.

In summary, lossless compression plays a significant role in IoT to optimize data handling and transmission by reducing data size without sacrificing data accuracy, making it a valuable tool for managing high data volumes generated by IoT devices.

Lossy compression Lossy compression methods are a DC approach in which less critical or redundant data is intentionally removed to achieve a significantly higher compression ratio, as described in [50]. In contrast to lossless compres-

sion, lossy compression intentionally sacrifices the precision of the data in order to significantly reduce the size of the compressed data. In the context of IoT, it proves beneficial for improving data transmission and storage efficiency, especially when limited data loss is acceptable. This helps to save network bandwidth and storage capacity, but should be used with caution as it is not suitable for applications that require complete data accuracy. The key is to find the right balance between compression and acceptable data loss, depending on the specific requirements of IoT applications.

Lossy compression algorithms can be broadly categorized based on the method employed to achieve compression. The four main categories are outlined and compared in Table 5.

Table 5: Evaluation of lossy compression strategies.

Approach	Advantages	Limitations
<i>Interpolation</i>	<ul style="list-style-type: none"> - Lower computational complexity. - Simple implementation. - Suitable for real-time compression. 	<ul style="list-style-type: none"> - Lower bandwidth consumption. - Inadequate representation of the original sample. - May not achieve significant compression for highly random data.
<i>AI Compression Methods</i>	<ul style="list-style-type: none"> - Adaptability to complex data with high-dimensional features. - Handling numerous inputs with low error tolerance. - Improved compression performance through ML. 	<ul style="list-style-type: none"> - High computational complexity. - Require pre-training. - Vulnerability to overfitting.
<i>Transformation Methods</i>	<ul style="list-style-type: none"> - Compatibility with various data types and formats. - Ability to capture latent data patterns for efficient compression. 	<ul style="list-style-type: none"> - Require data vectors as inputs. - Need a larger number of measurements.
<i>Hybrid Methods</i>	<ul style="list-style-type: none"> - Enhanced compression efficiency through a combination of techniques. - Efficient data size reduction. 	<ul style="list-style-type: none"> - High computational complexity. - Slower response time, in cases where multiple methods are involved.

Interpolation methods stand out for their lower computational complexity when compared to other techniques. These methods typically employ threshold tolerance parameters to effectively manage compression errors, making them especially suitable for real-time DC applications, such as those involving time-domain sensor measurements. Hybrid methods, on the other hand, leverage a combination of both lossy and lossless DC techniques. However, it's important to note that hybrid approaches may come with a trade-off of higher computational complexity. Transformation methods focus on converting data from one domain to another, often yielding favorable compression results. These methods necessitate data vectors as inputs and require a reasonable number of measurements to attain satisfactory compression outcomes. AI methods tend to entail more intricate implementations and often require a pre-training process. These

approaches are particularly well-suited for scenarios characterized by numerous inputs and complex system data.

The above observations are consistent with the findings documented in [43], where a comprehensive analysis of diverse lossy compression methods is reported, with specific emphasis on their relevance within IoT environments.

3.2 Data aggregation

Data aggregation (DA) combines multiple sensor data points and simultaneously eliminates redundant information. This process is orchestrated by an edge device, such as a gateway or router, which performs the initial data processing and subsequently forwards the information in its processed state instead of the raw, unprocessed data. The importance of this process is particularly evident due to the inherent limitations of sensor devices: They often have limited memory capacity, and their buffers may not be sufficient to hold all incoming data, potentially leading to packet loss. Apart from data loss, this can put a significant strain on network traffic as nodes have to retransmit the dropped packets, resulting in increased energy consumption on sensor devices and increased latency. To overcome these challenges, DA involves the integration of correlated data at intermediate nodes referred to as *aggregators* which can run on edge nodes. Depending on specific application requirements, an aggregator applies aggregation functions to the received data, e.g. numerical or statistical operations such as minimum, maximum, sum, average, and others. As a result, DA not only reduces the number of data packets and the overall network traffic, but also reduces latency and power consumption for edge nodes, as elaborated in [8].

DA protocols define the standard operating procedures to:

- aggregate the collected data based on an aggregation function,
- handle the exchanges of data and control messages in an IoT environment, and
- forward the aggregates to the base station (BS)/edge node/cloud.

The primary objectives of DA protocols include the elimination of redundant data transfers from source nodes to higher layers of the IoT architecture, the preservation of data accuracy during aggregation, and the enhancement of the operational lifetime of the entire IoT solution.

There are a number of studies applying DA protocols with diverse applications and operational characteristics which take into account: the topology of an IoT environment and its dynamic aspects, security considerations and different models for handling interference. A comprehensive exploration of existing methods for DA in IoT was conducted by Pourghebleh et al. [51]. The authors classify methods as tree-based, cluster-based and centralized, and assess them based on energy efficiency and latency. Compressed sensing, a powerful tool for efficient data acquisition and signal reconstruction, shows promise in IoT DA. However, it often sacrifices energy efficiency and recovery fidelity and it is challenging to find a balance between a prolonged lifetime of an IoT deployment and resource

utilization of constrained devices. Amarlingam et al. [52] tackled this issue with the Light Weight Compressed Data Aggregation (LWCDA) algorithm. It divides the network of IoT devices into non-overlapping clusters, reducing data transmissions within each cluster. When the number of IoT devices increases and data redundancy becomes prevalent, the key challenge lies in aggregating non-redundant data. Idrees et al. [53] devised a two-stage DA mechanism named IDiCoEK, using a divide-and-conquer algorithm to eliminate redundant data. Their approach employs an extended K-Means algorithm to filter out redundancy and determine optimal representative data for aggregation.

The IoT-edge-cloud continuum is an optimal computing environment which can offer localized data access, reduce transmission delays and enable decentralized DA, resulting in more efficient resource management and energy conservation for IoT and edge devices [54].

3.3 Data prediction

In the context of IoT, data prediction (DP) employs advanced analytics and ML algorithms to forecast future data trends based on historical data patterns. This predictive capability enables IoT devices and networks to proactively optimize data transmission and reception patterns, thereby improving inefficiencies in data traffic management [55].

In DP methods, a model is created that represents a captured phenomenon and allows requested values to be retrieved based on the predictions of the model rather than the directly sensed data. Many prediction methods have been proposed in literature as effective tools to reduce data collection and transmission rates in IoT. These techniques can be broadly categorized into two main approaches based on the location of the model within an IoT environment [56]:

1. single prediction and
2. dual prediction.

In the *single prediction* approach, predictions are made at a single point in the network, such as the sensor node or edge gateway. The method outlined in [57] involves implementing a prediction algorithm at the sensor node level. In this approach, the data readings gathered by a sensor node in the initial period are utilized to predict the sensor readings for the subsequent period. These initial period sensor readings are always sent to the gateway after compression. Then, in the following period, the similarity between the predicted data and the new sensor readings is computed. If the similarity score meets or exceeds a predefined threshold, the new data is not transmitted to the gateway. An alternative approach to single prediction involves scheduling alternating periods of data transmission and DP [58]. During the DP period, the collection of actual measurements from sensor nodes is omitted. The authors employed a deep learning technique to develop a prediction model deployed on gateways that allows prediction of sensor readings.

In *dual prediction* systems, the prediction models are utilized both at the IoT nodes and in the IoT-edge-cloud continuum. An IoT node continuously

compares the current observation with the predicted value. If the measured value falls within the predefined error range, the model remains valid. However, if the measured value deviates beyond this threshold, the source node can transmit the sampled data and potentially initiate a model update procedure. The design and characteristics of a DP method depend essentially on the specifics of the model's construction.

In [59], the authors propose a reliable dual prediction data reduction approach for Wireless Sensor Networks (WSNs). This approach operates through two phases to achieve data reduction. The first phase aims to decrease the number of transmissions between the sensor node and the sink node, thereby minimizing energy consumption. It also detects faulty data at the sensor nodes and discards them. The discarded faulty data at the sensor nodes are replaced by estimated values at the sink node to maintain data reliability. The Dual Prediction Process (DPP) runs at the sink node or base station, working in synchronization with the sensor nodes. This phase is responsible for predicting the non-transmitted data based on the Kalman filter. Simulation results demonstrate that the proposed approach is efficient and effective in reducing data, ensuring data reliability, and minimizing energy consumption.

In another study [60], the authors present a method to reduce data transmissions in sensor networks during target node selection for monitoring tasks. Their approach empowers an IoT gateway to decide when sensor nodes should report their data readings. By utilizing a prediction algorithm that employs an instance-based learning technique to assess potential future change rates of sensor readings, the gateway determines the necessity of selecting a new target node and transmits data only when essential for accurate target node selection. Experiments were conducted on a WSN with mobile devices, where the target node was the closest device to a specified location. The results demonstrated a significant reduction in transmitted data and precise target node selection with the proposed method.

The prediction algorithms can be broadly categorized into three classes:

- **Stochastic approaches:** Rely on statistical properties and probabilities to characterize the phenomenon. They often involve mapping data to a random process described by a probability density function (pdf) and predicting future data by combining computed pdfs with observed samples,
- **Algorithmic approaches:** Utilize heuristic or state transition models to describe the phenomenon being analyzed. These approaches do not rely solely on statistical properties but instead focus on building and updating models based on predefined algorithms or procedures, and
- **Time series forecasting:** Involves using historical values from a time series obtained through periodic sampling to predict future values within the same series.

Since time series data streams are frequently generated by devices in IoT environments, time series forecasting is a prevalent DP method in literature. In addition, stochastic and algorithmic approaches can be computationally intensive and may require significant processing power and memory. Since IoT and

edge devices have limited resources, implementing complex stochastic models may not be practical and thus in this paper we further investigate time series forecasting.

Time series forecasting uses a series of historical values obtained by periodic sampling to predict a future value in the same series. The main difference from other statistical or probabilistic approaches is that time series analysis explicitly considers the internal structure of the data. In general, a time series can be represented as a combination of a pattern and a random error, where the pattern is in turn characterized by its trend, i.e., its long-term change, and its seasonality, i.e., its periodic variation. Once the pattern is fully characterized, the resulting model can be used to predict future values in the time series. ML architectures used in literature for time series forecasting include [61]: LSTM (Long-Short Term Memory) because of their high prediction accuracy and ability to automatically process input sequences; CNN (Convolutional Neural Networks), which are mainly used in human activity recognition; hybrid architectures with a convolutional layer for data preprocessing; RNN (Recurrent Neural Networks) for data fusion from different sensors and their subsequent classification; and stacked LSTM autoencoders, which extract variables from time series without manual data preprocessing. For example the study reported in [62] demonstrated that the effectiveness of reducing data transmission in an IoT system depends largely on the specific prediction algorithm used. The authors conducted a comparison of different prediction algorithms based on their accuracy, delay, and the percentage of reduction in transmission. Additionally, neural networks and LSTM networks have been proposed for dual prediction schemes with online model training.

3.4 Choosing the right data reduction technique

Selecting the most suitable technique for data reduction in the IoT-edge-cloud continuum requires careful consideration of its efficiency and accuracy by solution architects at each layer of the continuum. These techniques play a critical role in optimizing the efficiency of data transmission, storage, and processing within IoT systems [63]. The primary objective is to minimize the amount of data transferred in the continuum while preserving important information for analysis and decision-making.

The choice of the appropriate technique depends on several key factors:

- **Data type and required accuracy:** The type of data being collected and the accuracy required for the analysis significantly influence the choice. For example, applications that focus on general trends may utilize DA effectively, while applications that require high accuracy of measurements may favor minimal lossless compression techniques.
- **Available resources:** The processing power and memory constraints of the deployed IoT devices play a crucial role. Resource-constrained devices at the edge necessitate simpler techniques such as data filtering or lightweight compression, while gateways or cloud servers can handle more sophisticated methods such as ML or neural networks.

- **Trade-off between efficiency and accuracy:** It is important to find a balance between the efficiency of data reduction while preserving data accuracy. Techniques such as DC can significantly reduce transmission volume, but may result in loss of detail, especially with lossy algorithms. Conversely, data filtering transmits only relevant data but may discard potentially valuable information.

Comparison of data reduction techniques Unlike communication protocols, a direct comparison of data reduction techniques without a given usage context is challenging due to the inherent variability of these methods. DP algorithms, for example, leverage diverse approaches such as ML or neural networks, each with distinct computational demands and characteristics. Additionally, the size of the deployed model itself significantly impacts the overall efficiency. Therefore, the effectiveness of each method depends heavily on the specific application, dataset properties, and the underlying IoT system’s resource constraints. Figure 4 offers a comparative analysis of the presented techniques based on four key criteria crucial for the data reduction in the IoT-edge-cloud continuum, where we rate each criteria on a scale from 0 (the lowest) to 5 (the highest):

1. **Energy consumption:** The technique’s impact on device battery lifetime and overall system energy usage;
2. **The volume of generated traffic:** The amount of data transmitted after applying the technique;
3. **Required processing power:** The computing resources required by the device to implement the technique; and
4. **Accuracy of data reconstruction:** The ability to recover the original data from the reduced representation.

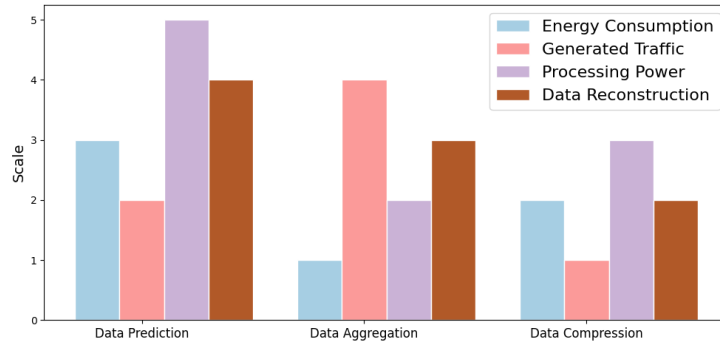

Fig. 4: Comparison of data reduction methods for IoT environments.

Generally, DA offers a good balance between efficiency and complexity. It combines multiple data points into a single, representative value, reducing data

transfer but potentially sacrificing some detail. However, it proves to be an energy-efficient approach. In contrast, DC is highly effective in reducing data traffic with moderate energy consumption, making it a compelling choice for minimizing data transmission in IoT environments. However, the potential loss of detail, especially with lossy algorithms, needs to be considered. DP is considered valuable for forecasting future values based on historical trends, but prediction methods require more processing power and energy compared to other techniques. Optimal selection often involves a combination of these techniques, tailored to achieve the best outcomes for a specific IoT use case. Furthermore, the placement of these methods within the IoT architecture has a significant impact on their effectiveness, as explored in detail in the following subsection.

In summary, each data reduction technique offers distinct advantages and limitations. A careful evaluation of the above factors, as well as their strategic placement within the IoT architecture, is critical for selecting the most suitable approach to achieve the desired balance between efficiency and accuracy in an IoT solution.

Placement of data reduction techniques within the IoT-edge-cloud continuum The placement of data reduction techniques within the IoT-Edge-Cloud continuum, as illustrated in Figure 1, is another key design consideration. Solution architects must strategically select IoT and edge devices which generate, transmit and process data streams that could host a data reduction technique which offers the greatest overall effectiveness. Several factors influence the placement of these techniques. Firstly, the *specific requirements of an application and the capabilities of the devices* involved need to be considered. This involves balancing the desired level of data reduction with the processing capacity of the deployed devices. For instance, resource-constrained sensor nodes located closer to a data source are better suited for simpler techniques, while devices with higher processing power, such as gateways or cloud servers, can handle more complex algorithms. Secondly, a *desired level of data reduction and the communication protocols used* within the environment also affect placement decisions. A higher level of data reduction may require more processing power, potentially shifting placement closer to higher capacity devices at the near edge or even in the cloud. Moreover, the efficiency of communication protocols within the architecture plays a significant role. Techniques positioned closer to a data source can reduce the volume of data transmitted using less efficient protocols. By carefully weighing these considerations, architects can strategically position data reduction techniques, thereby optimizing resource utilization and achieving the desired level of data reduction within the constraints of the IoT application.

Building on the importance of strategically placing data reduction techniques within the IoT-edge-cloud continuum, a more detailed exploration of specific approaches suitable for different layers can be undertaken. Hereafter we examine the techniques employed on resource-constrained devices at the device and edge layer, as described in Section 2.

Data reduction at device layer Data processing on end devices is limited by the processing performance, memory and available energy of the microcontroller. In many cases, a microcontroller is connected to the network via wireless technology and is powered by a battery. In this case, in addition to processing performance and memory size, energy consumption is also crucial, as it is consumed for generating sensor readings, data processing and communication. Since devices may be located in places where battery replacement is impractical or costly, energy efficiency is crucial for many application domains, e.g. environmental monitoring or smart agriculture. Limited memory and processing power enable IoT devices to perform only simple data analysis. DC is a suitable technique for data reduction on such devices [64] which removes redundant data before transmission to the gateway, thus maintaining data quality while reducing volume. If the devices are categorized as Class 2, or occasionally Class 1, more demanding reduction methods can be used, such as DP with a more lightweight algorithm which employs an ML inference model which can run on the available hardware.

Data reduction at edge layer Edge devices, such as efficient data servers, routers, or embedded systems, receive data from IoT devices and vary widely in hardware and operating systems. Gateways, which are often single-board computers like Raspberry Pi, have more processing power (typically an ARM processor) and large amounts of memory (up to several GB), allowing for more complex data processing than at the device layer. In addition, gateway nodes can collect and store data from multiple endpoints, analyze it, and send commands rapidly either upwards toward the cloud or backwards to an actuating device, making DA techniques appropriate for gateways. DP techniques can also be implemented on edge nodes, especially on near edge devices, as they have higher processing power compared to IoT devices [65]. Neural networks can be deployed on gateways to handle missing or noisy data [66]. Another approach involves deploying an ML model on the edge device, where the model predicts values based on sensor data and compares them to sensed values. If they align well within a pre-defined threshold, the data is considered accurate, avoiding transmission over the network. In the cloud, a similar model instance used which calculates the value, instead of receiving it from an IoT devices. This technique can greatly reduce the overall data traffic towards the cloud, but it relies on accurate prediction models. In cases when all sensed data needs to be sent to the cloud for further analysis or storage, compression methods can be applied to reduce the packet size, and thus save bandwidth and storage space. In scenarios with multiple devices measuring similar data where aggregation occurs at a higher layer, data merging or joining is effective to reduce the overall transmitted data. This multi-layered approach optimizes resource utilization, improves efficiency, and accelerates decision-making in the IoT-edge-cloud continuum.

The Figure 5. outlines the discussed data reduction strategies applicable across various layers within the IoT architecture, showcasing three distinct layers: the IoT device layer, the edge layer (comprising far and near edge), and the cloud layer. Within each layer, distinct techniques such as Data Compres-

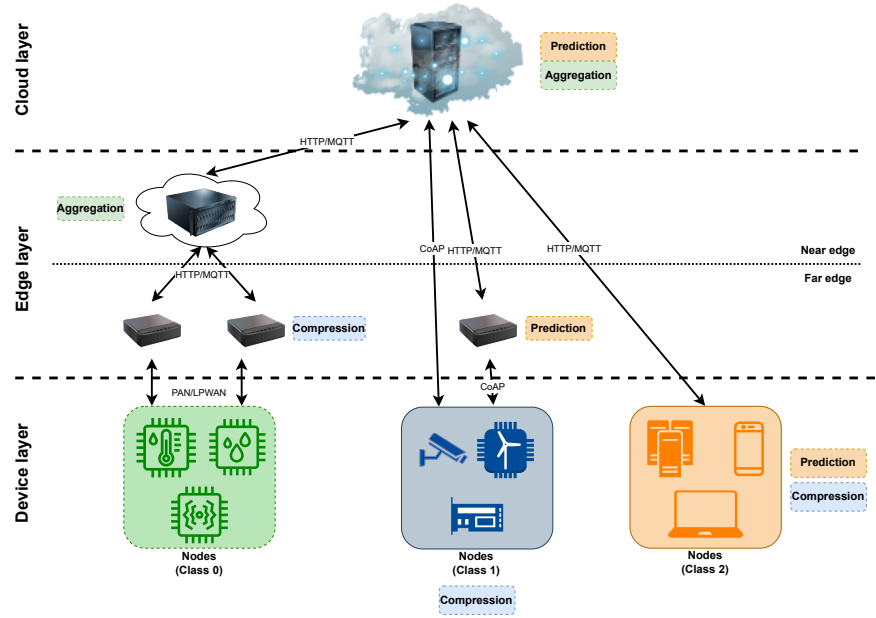

Fig. 5: Distribution of data reduction techniques across different layers of the IoT architecture

sion (DC), Data Prediction (DP), and Data Aggregation (DA) are applied to streamline data processing and transmission.

The application of these techniques varies depending on the characteristics of the devices and the specific requirements of the IoT ecosystem. For instance, in the IoT device layer, devices classified as Class 0 may have limited capabilities, making traditional data reduction methods impractical. However, by transitioning to the far edge layer, efficient data compression techniques can be employed to optimize data transmission. Moreover, at the near edge layer, data aggregation plays a pivotal role in balancing efficiency and complexity while preserving essential data details.

Devices classified as Class 1 typically possess sufficient resources to execute compression algorithms effectively. In such cases, deploying predictive models at the near edge layer can enhance data processing efficiency by transmitting only significant deviations from predetermined thresholds. In contrast, devices falling under Class 2 exhibit higher capabilities, enabling them to directly employ prediction techniques without the need for intermediate aggregation steps. This streamlined approach not only optimizes resource utilization but also accelerates decision-making processes within the IoT network. Moreover, it is essential to underscore the versatility of data prediction techniques. Beyond their deployment at the edge layers, specific instances of predictive models are also seamlessly

integrated into the cloud layer. This ensures that data not transmitted is still retained in the cloud for subsequent analysis and utilization.

In summary, the selection and implementation of data reduction techniques within the IoT architecture are intricately linked to specific use case scenarios, device capabilities, and network considerations. Strategically deploying these techniques across different layers can lead to optimization of resource utilization, and enhancement of overall system performance.

4 Open challenges and research directions for efficient data transmission strategies in the IoT-edge-cloud continuum

Choosing the appropriate communication technology, as described in Section 2, is a prerequisite for optimal data transmission in the IoT-edge-cloud continuum, while data reduction strategies presented in Section 3 facilitate information exchange with significantly less data traffic. In this section, we outline the emerging concepts that have the potential to further enhance IoT communication by reducing the associated network traffic: cross-layer optimization and edge-AI techniques for data reduction.

4.1 Cross-layer optimization

Traditional communication network design follows the Open Systems Interconnection (OSI) model, which separates protocol functionalities into distinct layers. Unfortunately, the technologies within each layer are often developed in isolation without considering their impact on other layers. This lack of attention to cross-layer interactions [67] is known to have a significant impact on end-to-end (E2E) delay and reliability.

To overcome these limitations, cross-layer design promotes collaboration between layers for improved network performance. It falls into two categories [68]: loosely coupled or tightly coupled cross-layer design, where both are based on establishing cross-layer interactions.

In a *loosely coupled cross-layer design*, the focus is on optimizing a specific protocol layer without direct interaction with other layers. However, disconnected layers share information through interfaces or by using a common database. Thus, information from other layers is taken into account to improve the performance of the targeted layer. For example, the physical layer can pass channel quality information to the TCP layer so that it can differentiate between packet loss and congestion to enable more effective congestion control.

In contrast, a *tightly coupled cross-layer design* goes beyond simple information exchange between the layers. In this approach, layer separation disappears and the algorithms of the different layers are optimized together as part of a single optimization problem. While a tightly-coupled cross-layer design offers

superior performance improvements, the advantage of a loosely-coupled cross-layer design is that it maintains transparency between the protocol layers instead of giving it up completely.

Cross-layer design has long been present as a possible approach towards enhancing communication performance through better resource allocation [69], power control [70] and congestion control [71]. However, this design violates the highly interconnected composition of layers in the OSI model. Each modification of such a model creates many unforeseen consequences that often reduce the efficiency of the entire system. While its development complexity limits widespread adoption, research demonstrates that cross-layer design has potential for optimization in various communication scenarios, particularly for specific Quality-of-Service (QoS) parameters [72,73]. Cross-layer solutions are often targeted and application-specific to improve a specific communication parameter.

The cross-layer approach was often used in use cases related to WSNs because of the constraints of participating sensor devices [74]. One popular example that showcases the benefits of OSI layer adaptation in this context is the 6LoWPAN protocol (developed by the 6LoWPAN IETF group) which implies the optimization of IPv6 packets from the network layer for their transmission over low-power wireless networks operating in lower layers, typically based on IEEE 802.15.4. Thus, cross-layer optimization could have a significant role in reducing the overall data traffic in IoT, especially at the edge where participating devices often cannot even support the full IP stack, as previously described.

4.2 Edge AI techniques for IoT data reduction

The growth of resource-rich devices at the network edge offers an opportunity to distribute processing tasks from the cloud to devices that are closer to the targeted local environments. The execution of data processing closer to the data sources in IoT offers a wide range of opportunities to optimize the overall system performance and achieve benefits such as reduced latency, lower bandwidth, and improved security. This section explores how Edge AI complements data reduction methods presented in Section 3 by enabling intelligent local data processing and real-time analysis.

Edge AI executes machine learning (ML) algorithms on IoT and edge devices, analyzing data relevance before transmission to the cloud for in-depth analysis. By decentralizing AI processing from the cloud to edge devices, Edge AI enables real-time data analysis, reduced latency and improved privacy protection. This paradigm shift is fundamentally changing the landscape of AI applications and paving the way for a new era of intelligent and responsive systems. This decentralization from cloud-based AI offers several advantages [75]:

- **Reduced latency:** Edge AI reduces the load on cloud platforms and leads to a significant reduction in latency while also freeing cloud resources for more complex tasks.
- **Efficient data transmission:** Edge AI significantly contributes to reducing the required bandwidth by processing, analyzing, and storing data locally.

This localized approach means less information needs to be transferred to the cloud, resulting in a streamlined data flow.

- **Improved security:** Edge AI contributes to increased security by limiting the amount of data sent to centralized cloud storage. The vulnerability associated with all data residing in a single cloud storage is mitigated as some data is processed and stored within an edge network. When data needs to be transferred to the cloud, Edge AI also filters out redundant, superfluous and unnecessary information and only sends the important data.
- **Scalability and flexibility:** The ability to seamlessly extend and customize the system is facilitated by distributed processing and analysis at the edge of the system. This inherent scalability ensures that the AI system can grow effortlessly to meet evolving requirements, while the flexibility of Edge AI enables adaptable functionality for different applications and environments.

Different technologies are used in Edge AI. These include edge orchestration frameworks [76], ML frameworks, neural network architecture, model compression, federated learning [77], and edge-to-cloud integration. The implementation of Edge AI software requires efficient hardware that is able to process data from various devices or sensors while consuming as little power as possible. The challenge is to achieve high algorithm accuracy without compromising energy efficiency. However, the advancement of hardware options such as central processing units (CPUs), graphics processing units (GPUs), application-specific integrated circuits (ASICs) and system-on-chip accelerators (SoCs) has made Edge AI feasible [78]. To support the development and deployment of Edge AI models, ML software frameworks like TensorFlow Lite, PyTorch Mobile, and ONNX Runtime provide valuable tools. These frameworks come equipped with features such as model optimization and deployment tools, optimizing resource utilization and performance on edge devices [79].

Model compression [80] is a technique that plays an important role in this ecosystem by reducing the size of ML models to fit the resources of edge devices so that inference is performed close to data sources. By eliminating redundant information, it enables the execution of models on nodes with limited resources. Federated learning is another key aspect, offering a methodology that allows the training of ML models using distributed data sources without the need to share raw data [77]. This approach not only enhances privacy but also reduces network traffic. Moreover, edge-to-cloud integration creates hybrid solutions that leverage the strengths of both edge and cloud computing. This capability supports real-time processing on edge devices and facilitates model training on the cloud. In combination, these technologies contribute to a comprehensive and cohesive approach to Edge AI.

Various techniques are applied at the edge, and a comprehensive survey of AI-related algorithms suitable for edge applications is presented in [81]. Part of the outlined technique categories include data reduction strategies described previously in Section 3. Therefore, the application of such AI techniques, mainly related to data preprocessing and data analytics at the edge layer, is the right

approach to take advantage of the benefits that these techniques offer in the context of reducing the amount of data generated towards the public network.

Data preprocessing techniques play a central role in mitigating the volume of IoT data by eliminating irrelevant, redundant or noisy information. Common preprocessing methods include filtering, feature extraction, normalization and data prediction. Filtering involves discarding data that does not fulfill certain criteria, while feature extraction identifies and retains the most important information, thereby reducing the amount of data without compromising on quality. Normalization ensures data consistency and thus improves the performance of ML algorithms. Furthermore, imputation fills in missing values, increasing the accuracy of the data analysis. In addition, data compression is another technique that can be used at the edge, a topic that is explained in more detail in Section 3.1.

Open issues and trends The following are potential open issues and emerging trends for the future of Edge AI:

- **Data loss:** Implementing edge AI requires careful planning to avoid data loss. Though many edge devices discard irrelevant data properly, there is a risk of losing relevant data, impacting subsequent analyses.
- **Limited computing power:** While effective, Edge AI lacks the computing power [82] of cloud-based AI, restricting certain tasks to edge devices. Cloud computing remains essential for large models, while edge devices excel in on-device inference and modest transfer learning tasks.
- **Hardware variations:** Relying on edge devices introduces machine type variations, increasing the likelihood of errors due to diverse capabilities and limitations, posing potential challenges to system reliability.
- **ML model variations:** Different hardware requires different inference models which match the available resources. New challenges arise since such models offer different accuracy and inference latency.
- **Privacy and security:** Ensuring privacy and security in processing data on local devices will be a critical consideration for Edge AI. Techniques like federated learning, enabling local model training without exchanging raw data, will gain increased significance.

5 Conclusion

The IoT-edge-cloud continuum is a hierarchical and layered computing architecture that integrates IoT devices, edge nodes with heterogeneous computing resources, and the cloud to form a unified environment for deployment of modern IoT solutions which are responsive, efficient, secure and scalable. However, this environment introduces new challenges due to its complexity and the resource limitations of edge devices compared to powerful cloud resources. In particular, efficient data transmission within this complex ecosystem presents a challenge due to the utilization of heterogeneous hardware, wireless technologies and application-layer protocols. Data reduction strategies are a viable approach

to facilitate efficient data transmission in the IoT-edge-cloud continuum, but a holistic view is needed to identify promising techniques and their potential position within the continuum in line with the limitations of the environment.

This paper provides such a holistic view by analyzing the communication technologies and protocols, data reduction techniques and their combined use and placement with the IoT-edge-cloud continuum.

We first compared the wireless communication technologies for the IoT-edge-cloud continuum based on the range, power consumption, and throughput to conclude that the most energy-efficient protocol which meets the range and data rate requirements of a specific IoT use case should be chosen for communication between IoT devices and the gateway. For communication between the gateway or edge device and the cloud, CoAP, which implements the low-latency request-response model, and MQTT, which offers scalable and flexible one-to-many interaction, are ideal for minimizing traffic within the continuum. Further optimization strategies can be explored based on data types, transmission frequency, and the overall IoT-edge-cloud environment.

Next, we explored the following data reduction strategies applicable at the IoT device, gateway and edge level: Data Compression (DC), Data Prediction (DP) and Data Aggregation (DA). They were compared based on energy consumption, traffic volume, processing power and accuracy. An optimal strategy for data reduction involves a combination of these techniques, tailored to the specific use case with careful planning of their placement within the continuum. DC is commonly deployed on the IoT device and far edge nodes, and proves effective in minimizing data transmission but may involve some data loss with lossy algorithms. DA provides a good balance between efficiency and complexity by reducing data transmission while retaining some detail. DA solutions are deployed at the remote or near edge nodes. DP is valuable for forecasting future values, but requires more processing power and energy. It would be beneficial to deploy DP techniques on IoT devices, but due to limited resources far edge nodes are a better choice.

Finally, we explored cross-layer optimization and Edge AI techniques, which are promising and emerging concepts with potential to further reduce the communication overhead in the IoT-edge-cloud Continuum. Cross-layer optimization promotes collaboration between layers for improved network performance and shows potential to optimize various Quality-of-Service (QoS) aspects like resource allocation, power control, and congestion control. However, the complexity of development and potential to cause unintended far-reaching consequences limit its widespread adoption. Edge AI shows further potential to reduce data traffic in the continuum by placing ML models across the continuum to perform real-time, intelligent data analysis at the network edge. However, there are also challenges to consider, such as potential data loss, limited computing power of edge devices, hardware and ML model variations, as well as privacy and security concerns.

Beyond these approaches, semantic and goal-oriented communication present an exciting future research direction in the field of communication systems, fo-

ocusing on transmitting the meaning of data rather than raw content for improved efficiency. Semantic and goal-oriented communication is outside the scope of this paper, and we intend to explore it further in our future work.

Acknowledgements

This work has been supported in part by Croatian Science Foundation under the project IP-2019-04-1986 *IoT4us: Smart human-centric services in interoperable and decentralised IoT environments* and by the Horizon Europe WIDERA program under the grant agreement No. 101079214 (*AIoTwin*).

References

1. Weisong Shi and Schahram Dustdar. The promise of edge computing. *Computer*, 49(5):78–81, 2016.
2. Latif U. Khan, Ibrar Yaqoob, Nguyen H. Tran, S. M. Ahsan Kazmi, Tri Nguyen Dang, and Choong Seon Hong. Edge-computing-enabled smart cities: A comprehensive survey. *IEEE Internet of Things Journal*, 7(10):10200–10232, 2020.
3. Jesús Martín Talavera, Luis Eduardo Tobón, Jairo Alejandro Gómez, María Alejandra Culman, Juan Manuel Aranda, Diana Teresa Parra, Luis Alfredo Quiroz, Adolfo Hoyos, and Luis Ernesto Garreta. Review of iot applications in agro-industrial and environmental fields. *Computers and Electronics in Agriculture*, 142:283–297, 2017.
4. Zhibin Guan, Tongkai Ji, Xu Qian, Yan Ma, and Xuehai Hong. A survey on big data pre-processing. In *2017 5th Intl Conf on Applied Computing and Information Technology/4th Intl Conf on Computational Science/Intelligence and Applied Informatics/2nd Intl Conf on Big Data, Cloud Computing, Data Science (ACIT-CSII-BCD)*, pages 241–247, 2017.
5. Laercio Pioli Junior, Carina Dorneles, Douglas Macedo, and Mario Dantas. An overview of data reduction solutions at the edge of iot systems: a systematic mapping of the literature. *Computing*, 104:1–23, 08 2022.
6. Apostolos Gerodimos, Leandros Maglaras, Mohamed Amine Ferrag, Nick Ayres, and Ioanna Kantzavelou. Iot: Communication protocols and security threats. *Internet of Things and Cyber-Physical Systems*, 3:1–13, 2023.
7. Ihab Nassra and Juan V. Capella. Data compression techniques in iot-enabled wireless body sensor networks: A systematic literature review and research trends for qos improvement. *Internet of Things*, 23:100806, 2023.
8. Beneyaz Ara Begum, Satyanarayana V Nandury, et al. A survey of data aggregation protocols for energy conservation in wsn and iot. *Wireless Communications and Mobile Computing*, 2022, 2022.
9. Carsten Bormann, Mehmet Ersue, and Ari Keränen. Terminology for Constrained-Node Networks. RFC 7228, May 2014.
10. Miljan Sikimić, Momčilo Amović, Vladimir Vujović, Bojan Suknović, and Dragan Manjak. An overview of wireless technologies for iot network. In *2020 19th International Symposium (INFOTEH)*, pages 1–6, 2020.
11. Arup Barua, Md Abdullah Al Alamin, Md. Shohrab Hossain, and Ekram Hossain. Security and privacy threats for bluetooth low energy in iot and wearable devices: A comprehensive survey. *IEEE Open Journal of the Communications Society*, 3:251–281, 2022.

12. Alireza Zohourian, Sajjad Dadkhah, Euclides Carlos Pinto Neto, Hassan Mahdikhani, Priscilla Kyei Danso, Heather Molyneaux, and Ali A. Ghorbani. Iot zigbee device security: A comprehensive review. *Internet of Things*, 22:100791, 2023.
13. Sinem Coleri Ergen. Zigbee/ieee 802.15. 4 summary. *UC Berkeley, September*, 10(17):11, 2004.
14. Artem Dementyev, Steve Hodges, Stuart Taylor, and Joshua Smith. Power consumption analysis of bluetooth low energy, zigbee and ant sensor nodes in a cyclic sleep scenario. In *2013 IEEE International Wireless Symposium (IWS)*, pages 1–4, 2013.
15. Anirudh Ganji, Griffin Page, and Muhammad Shahzad. Characterizing the performance of wifi in dense iot deployments. In *2019 28th International Conference on Computer Communication and Networks (ICCCN)*, pages 1–9, 2019.
16. Jetmir Haxhibeqiri, Eli De Poorter, Ingrid Moerman, and Jeroen Hoebeke. A survey of lorawan for iot: From technology to application. *Sensors*, 18(11), 2018.
17. Rashmi Sharan Sinha, Yiqiao Wei, and Seung-Hoon Hwang. A survey on lpwa technology: Lora and nb-iot. *ICT Express*, 3(1):14–21, 2017.
18. Almudena Diaz Zayas and Pedro Merino. The 3gpp nb-iot system architecture for the internet of things. In *2017 IEEE International Conference on Communications Workshops (ICC Workshops)*, pages 277–282, 2017.
19. Vamshi Sunku Mohan, Sriram Sankaran, Priyadarsi Nanda, and Krishnashree Achuthan. Enabling secure lightweight mobile narrowband internet of things (nb-iot) applications using blockchain. *Journal of Network and Computer Applications*, page 103723, 2023.
20. Richard Verhoeven, Stash Kempinski, and Nirvana Meratnia. Performance evaluation of wi-fi halow, nb-iot and lora for smart city applications. In *Proceedings of the 19th ACM International Symposium on Performance Evaluation of Wireless Ad Hoc, Sensor, and Ubiquitous Networks, PE-WASUN '22*, page 17–24, New York, NY, USA, 2022. Association for Computing Machinery.
21. Mojtaba Vaezi, Amin Azari, Saeed R. Khosravirad, Mahyar Shirvanimoghaddam, M. Mahdi Azari, Danai Chasaki, and Petar Popovski. Cellular, wide-area, and non-terrestrial iot: A survey on 5g advances and the road toward 6g. *IEEE Communications Surveys and Tutorials*, 24(2):1117–1174, 2022.
22. Tong Ji, Wenhao Li, Xiangcheng Zhu, and Mengshuang Liu. Survey on indoor fingerprint localization for ble. In *2022 IEEE 6th Information Technology and Mechatronics Engineering Conference (ITOEC)*, volume 6, pages 129–134, 2022.
23. Ievgeniia Kuzminykh, Arkadii Snihurov, and Anders Carlsson. Testing of communication range in zigbee technology. In *2017 14th International Conference The Experience of Designing and Application of CAD Systems in Microelectronics (CADSM)*, pages 133–136, 2017.
24. Shailandra Kaushik. An overview of technical aspect for wifi networks technology. *International Journal of Electronics and Computer Science Engineering*, 1, 04 2012.
25. Ferran Adelantado, Xavier Vilajosana, Pere Tuset-Peiro, Borja Martinez, Joan Melia-Segui, and Thomas Watteyne. Understanding the limits of lorawan. *IEEE Communications Magazine*, 55(9):34–40, 2017.
26. Jin-Shyan Lee, Yu-Wei Su, and Chung-Chou Shen. A comparative study of wireless protocols: Bluetooth, uwb, zigbee, and wi-fi. In *IECON 2007 - 33rd Annual Conference of the IEEE Industrial Electronics Society*, pages 46–51, 2007.
27. Abdullah Kurtoglu, Joan Carletta, and Kye-Shin Lee. Energy consumption in long-range linear wireless sensor networks using lorawan and zigbee. In *2017 IEEE 60th*

- International Midwest Symposium on Circuits and Systems (MWSCAS)*, pages 1163–1167, 2017.
28. Jin-Shyan Lee, Ming-Feng Dong, and Yuan-Heng Sun. A preliminary study of low power wireless technologies: Zigbee and bluetooth low energy. In *2015 IEEE 10th Conference on Industrial Electronics and Applications (ICIEA)*, pages 135–139, 2015.
 29. Jiun-ren Lin, Timothy Talty, and O.K. Tonguz. On the potential of bluetooth low energy technology in vehicular applications. *IEEE Communications Magazine*, 53:267–275, 02 2015.
 30. Massimo Ballerini, Tommaso Polonelli, Davide Brunelli, Michele Magno, and Luca Benini. Nb-iot versus lorawan: An experimental evaluation for industrial applications. *IEEE Transactions on Industrial Informatics*, 16(12):7802–7811, 2020.
 31. F. John Dian, Amirhossein Yousefi, and Sungjoon Lim. A practical study on bluetooth low energy (ble) throughput. In *2018 IEEE 9th Annual Information Technology, Electronics and Mobile Communication Conference (IEMCON)*, pages 768–771, 2018.
 32. C. Muthu Ramya, M Shanmugaraj, and R Prabaharan. Study on zigbee technology. In *2011 3rd International Conference on Electronics Computer Technology*, volume 6, pages 297–301, 2011.
 33. Luiz Oliveira, Joel J. P. C. Rodrigues, Sergei A. Kozlov, Ricardo A. L. Rabêlo, and Victor Hugo C. de Albuquerque. Mac layer protocols for internet of things: A survey. *Future Internet*, 11(1), 2019.
 34. Praveen Kumar Donta, Satish Narayana Srirama, Tarachand Amgoth, and Chandra Sekhara Rao Annavarapu. Survey on recent advances in iot application layer protocols and machine learning scope for research directions. *Digital Communications and Networks*, 8(5):727–744, 2022.
 35. Nitin Naik. Choice of effective messaging protocols for iot systems: Mqtt, coap, amqp and http. In *2017 IEEE International Systems Engineering Symposium (ISSE)*, pages 1–7, 2017.
 36. Muneer Bani Yassein, Mohammed Q. Shatnawi, and Dua' Al-zoubi. Application layer protocols for the internet of things: A survey. In *2016 International Conference on Engineering and MIS (ICEMIS)*, pages 1–4, 2016.
 37. Biswajeeban Mishra and Attila Kertesz. The use of mqtt in m2m and iot systems: A survey. *IEEE Access*, 8:201071–201086, 2020.
 38. Faheem Iqbal, Moneeb Gohar, Hanen Karamti, Walid Karamti, Seok-Joo Koh, and Jin-Ghoo Choi. Use of quic for amqp in iot networks. *Computer Networks*, 225:109640, 2023.
 39. Nguyen Quoc Uy and Vu Hoai Nam. A comparison of amqp and mqtt protocols for internet of things. In *2019 6th NAFOSTED Conference on Information and Computer Science (NICS)*, pages 292–297, 2019.
 40. Thays Moraes, Bruno Nogueira, Victor Lira, and Eduardo Tavares. Performance comparison of iot communication protocols. In *2019 IEEE International Conference on Systems, Man and Cybernetics (SMC)*, pages 3249–3254, 2019.
 41. Cavide Balkı Gemirter, Cagatay Senturca, and Sebnem Baydere. A comparative evaluation of amqp, mqtt and http protocols using real-time public smart city data. In *2021 6th International Conference on Computer Science and Engineering (UBMK)*, pages 542–547, 2021.
 42. Laith Farhan, Rupak Kharel, Omprakash Kaiwartya, Marcela Quiroz-Castellanos, Ali Alissa, and Mohamed Abdulsalam. A concise review on internet of things (iot) -problems, challenges and opportunities. In *2018 11th International Symposium*

- on *Communication Systems, Networks and Digital Signal Processing (CSNDSP)*, pages 1–6, 2018.
43. Juan David Arias Correa, Alex Sandro Roschildt Pinto, and Carlos Montez. Lossy data compression for iot sensors: A review. *Internet of Things*, 19:100516, 2022.
 44. Mohammad Hosseini. A survey of data compression algorithms and their applications. *Network Systems Laboratory, School of Computing Science, Simon Fraser University, BC, Canada*, 2012.
 45. Santosh Pattar, Rajkumar Buyya, K. R. Venugopal, S. S. Iyengar, and L. M. Patnaik. Searching for the iot resources: Fundamentals, requirements, comprehensive review, and future directions. *IEEE Communications Surveys and Tutorials*, 20(3):2101–2132, 2018.
 46. Emanuel Guberović, Fran Krišto, Petar Krivić, and Igor Čavrak. Assessing compression algorithms on iot sensor nodes. In *2019 42nd International Convention on Information and Communication Technology, Electronics and Microelectronics (MIPRO)*, pages 913–918, 2019.
 47. Ali Kadhum M. Al-Qurabat, Chady Abou Jaoude, and Ali Kadhum Idrees. Two tier data reduction technique for reducing data transmission in iot sensors. In *2019 15th International Wireless Communications and Mobile Computing Conference (IWCMC)*, pages 168–173, 2019.
 48. Davis W. Blalock, Samuel Madden, and John V. Guttag. Sprintz: Time series compression for the internet of things. *Proc. ACM Interact. Mob. Wearable Ubiquitous Technol.*, 2:93:1–93:23, 2018.
 49. Biljana Risteska Stojkoska and Zoran Nikolovski. Data compression for energy efficient iot solutions. In *2017 25th Telecommunication Forum (TELFOR)*, pages 1–4, 2017.
 50. Uthayakumar Jayasankar, Vengattaraman Thirumal, and Dhavachelvan Ponnurangam. A survey on data compression techniques: From the perspective of data quality, coding schemes, data type and applications. *Journal of King Saud University - Computer and Information Sciences*, 33(2):119–140, 2021.
 51. Behrouz Pourghebleh and Nima Jafari Navimipour. Data aggregation mechanisms in the internet of things: A systematic review of the literature and recommendations for future research. *Journal of Network and Computer Applications*, 97:23–34, 2017.
 52. M Amarlingam, Pradeep Kumar Mishra, Pachamuthu Rajalakshmi, Sumohana S Channappayya, and Challa S Sastry. Novel light weight compressed data aggregation using sparse measurements for iot networks. *Journal of Network and Computer Applications*, 121:119–134, 2018.
 53. Ali Kadhum Idrees, Ali Kadhum M Al-Qurabat, Chady Abou Jaoude, and Wathiq Laftah Al-Yaseen. Integrated divide and conquer with enhanced k-means technique for energy-saving data aggregation in wireless sensor networks. In *2019 15th International wireless communications & mobile computing conference (IWCMC)*, pages 973–978. IEEE, 2019.
 54. Huihui Xue, Bi Huang, Mingming Qin, Hua Zhou, and Hongji Yang. Edge computing for internet of things: A survey. In *2020 International Conferences on Internet of Things (iThings) and IEEE Green Computing and Communications (GreenCom) and IEEE Cyber, Physical and Social Computing (CPSCom) and IEEE Smart Data (SmartData) and IEEE Congress on Cybermatics (Cybermatics)*, pages 755–760. IEEE, 2020.
 55. Franklin Oliveira, Daniel G. Costa, Flávio Assis, and Ivanovitch Silva. Internet of intelligent things: A convergence of embedded systems, edge computing and machine learning. *Internet of Things*, 26:101153, 2024.

56. Gabriel Martins Dias, Boris Bellalta, and Simon Oechsner. A survey about prediction-based data reduction in wireless sensor networks. *ACM Computing Surveys (CSUR)*, 49(3):1–35, 2016.
57. Ahmed Mohammed Hussein, Ali Kadhum Idrees, and Raphael Couturier. Distributed energy-efficient data reduction approach based on prediction and compression to reduce data transmission in iot networks. *International Journal of Communication Systems*, 35(15):e5282, 2022.
58. Made Adi Paramartha Putra, Ade Pitra Hermawan, Dong-Seong Kim, and Jae-Min Lee. Data prediction-based energy-efficient architecture for industrial iot. *IEEE Sensors Journal*, 23(14):15856–15866, 2023.
59. Haibin Wang, Zaid Yemeni, Waleed Ismael, Ammar Hawbani, and Saeed Alsamhi. A reliable and energy efficient dual prediction data reduction approach for wsns based on kalman filter. *IET Communications*, page 1, 11 2021.
60. Bartłomiej Płaczek. Prediction-based data reduction with dynamic target node selection in iot sensor networks. *Future Generation Computer Systems*, 152:225–238, 2024.
61. Roberto Jacome, Miguel Realpe, Jonathan Paillacho-Corredores, and José-Leonardo Benavides-Maldonado. *Time Series in Sensor Data Using State-of-the-Art Deep Learning Approaches: A Systematic Literature Review*, pages 503–514. 01 2022.
62. Abdallah Jarwan, Ayman Sabbah, and Mohamed Ibnkahla. Data transmission reduction schemes in wsns for efficient iot systems. *IEEE Journal on Selected Areas in Communications*, 37(6):1307–1324, 2019.
63. Ali Akbar Sadri, Amir Masoud Rahmani, Morteza Saberikamarposhti, and Mehdi Hosseinzadeh. Data reduction in fog computing and internet of things: A systematic literature survey. *Internet of Things*, 20:100629, 2022.
64. Tulika Bose, Soma Bandyopadhyay, Sudhir Kumar, Abhijan Bhattacharyya, and Arpan Pal. Signal characteristics on sensor data compression in iot - an investigation. In *2016 IEEE International Conference on Sensing, Communication and Networking (SECON Workshops)*, pages 1–6. IEEE, 6 2016.
65. Cinthya M. França, Rodrigo S. Couto, and Pedro B. Velloso. Missing data imputation in internet of things gateways. *Information*, 12(10), 2021.
66. Cinthya M. França, Rodrigo S. Couto, and Pedro B. Velloso. Data imputation on iot gateways using machine learning. In *2021 19th Mediterranean Communication and Computer Networking Conference (MedComNet)*, pages 1–8, 2021.
67. Valeriy Ivanov and Maxim Tereshonok. Cross-layer methods for ad hoc networks—review and classification. *Future Internet*, 16(1), 2024.
68. Sultan Chowdhury and Ashraf Hossain. Different energy saving schemes in wireless sensor networks: A survey. *Wireless Personal Communications*, 114, 10 2020.
69. Leonidas Georgiadis, Michael Neely, and Leandros Tassiulas. Resource allocation and cross-layer control in wireless networks. *Foundations and Trends in Networking*, 1, 01 2006.
70. Asma Messaoudi, Rabiaa Elkamel, Abdelhamid Helali, and Ridha Bouallegue. Cross-layer based routing protocol for wireless sensor networks using a fuzzy logic module. In *2017 13th International Wireless Communications and Mobile Computing Conference (IWCMC)*, pages 764–769, 2017.
71. C. Wang, B. Li, K. Sohraby, M. Daneshmand, and Y. Hu. Upstream congestion control in wireless sensor networks through cross-layer optimization. *IEEE Journal on Selected Areas in Communications*, 25(4):786–795, 2007.

72. K. Swaminathan, Vijay Ravindran, Ramprakash Ponraj, and R. Satheesh. A smart energy optimization and collision avoidance routing strategy for iot systems in the wsn domain. In Brijesh Iyer, Tom Crick, and Sheng-Lung Peng, editors, *Applied Computational Technologies*, pages 655–663, Singapore, 2022. Springer Nature Singapore.
73. Nadine Hasan, Ayaskanta Mishra, and Arun Kumar Ray. Fuzzy logic based cross-layer design to improve quality of service in mobile ad-hoc networks for next-gen cyber physical system. *Engineering Science and Technology, an International Journal*, 35:101099, 2022.
74. Sultana Parween and Syed Zeeshan Hussain. A review on cross-layer design approach in wsn by different techniques. *Adv. Sci. Technol. Eng. Syst*, 5(4):741–754, 2020.
75. Raghubir Singh and Sukhpal Singh Gill. Edge ai: A survey. *Internet of Things and Cyber-Physical Systems*, 3:71–92, 2023.
76. Ivan Čilić, Petar Krivić, Ivana Podnar Žarko, and Mario Kušek. Performance evaluation of container orchestration tools in edge computing environments. *Sensors*, 23(8), 2023.
77. Chen Zhang, Yu Xie, Hang Bai, Bin Yu, Weihong Li, and Yuan Gao. A survey on federated learning. *Knowledge-Based Systems*, 216:106775, 2021.
78. Vittorio Mazzia, Aleem Khaliq, Francesco Salvetti, and Marcello Chiaberge. Real-time apple detection system using embedded systems with hardware accelerators: An edge ai application. *IEEE Access*, 8:9102–9114, 2020.
79. Di Liu, Hao Kong, Xiangzhong Luo, Weichen Liu, and Ravi Subramaniam. Bringing ai to edge: From deep learning’s perspective. *Neurocomputing*, 485:297–320, 2022.
80. Zhuo Li, Hengyi Li, and Lin Meng. Model compression for deep neural networks: A survey. *Computers*, 12(3):60, 2023.
81. Amira Bourechak, Ouarda Zedadra, Mohamed Nadjib Kouahla, Antonio Guerrieri, Hamid Seridi, and Giancarlo Fortino. At the confluence of artificial intelligence and edge computing in iot-based applications: A review and new perspectives. *Sensors*, 23(3), 2023.
82. Chellammal Surianarayanan, John Jeyasekaran Lawrence, Pethuru Raj Chelliah, Edmond Prakash, and Chaminda Hewage. A survey on optimization techniques for edge artificial intelligence (ai). *Sensors*, 23(3), 2023.