

Full-Duplex Beyond Self-Interference: The Unlimited Sensing Way

Ziang Liu, Ayush Bhandari, and Bruno Clerckx, *Fellow, IEEE*

Abstract—The success of full-stack full-duplex communication systems depends on how effectively one can achieve digital self-interference cancellation (SIC). Towards this end, in this paper, we consider unlimited sensing framework (USF) enabled full-duplex system. We show that by injecting folding non-linearities in the sensing pipeline, one can not only suppress self-interference but also recover the signal of interest (SoI). This approach leads to novel design of the receiver architecture that is complemented by a modulo-domain channel estimation method. Numerical experiments show that the USF enabled receiver structure can achieve up to 40 dB digital SIC by using as few as 4-bits per sample. Our method outperforms the previous approach based on adaptive filters when it comes to SoI reconstruction, detection, and digital SIC performance.

Index Terms—Digital self-interference cancellation, full duplex, unlimited sampling, quantization noise.

I. INTRODUCTION

Rapidly emerging frontiers of wireless communication systems have enabled new applications. Future growth of this area in terms of applications and transmission bandwidth poses strong restrictions on the frequency spectrum [1]. A promising solution to the *spectrum scarcity* problem has been the design of In-Band Full-Duplex (FD) systems [2], [3]. Recently, there has been a surge of research interest towards this solution. This is mainly because FD systems can potentially double the spectral efficiency of communication [2], [3]. However, when considering the FD solution as it is, there is a price to pay. That is, the coupling between the co-located transmitter and receiver causes severe self-interference (SI) (e.g. up to 100 dB [2], [4]). This results in an undesirable scenario where the signal of interest (SoI) containing the uplink data irretrievably drowns in the interference. On the one hand, simultaneous occurrence of SI and SoI naturally necessitates a high dynamic range (HDR) analog-to-digital converters or ADCs, or else, there will be no hope of recovering the uplink data from this occurrence. On the other hand, for a fixed bit budget, HDR ADCs entail higher quantization noise which can compromise the capability of existing algorithms. In this case, the only available remedy is to boost the number of bits used for digitization. This strategy, proves to be sub-optimal because higher bit-budget entails higher power consumption and cost. In crux, combating the effect of SI creates an inevitable trade-off between the bit-budget and the dynamic range.

Given the significance of this problem, several promising techniques for SI cancellation have been proposed in the

literature, including [2], [5]–[8]. Broadly, these methods can be classified as follows: 1) **Analog Domain**: The key concept here is to generate a negative copy by the canceller circuit, and this replica is subtracted from the received signal [5], [6]. However, the analog-domain signal processing is especially difficult and entails high hardware complexity (compared to digital implementation). And even then, this does not enable complete cancellation of the SI, resulting in unwanted residuals [2] and can even sometimes increase the SI based on the experiment [9]. This has motivated the development of digital methods. 2) **Digital Domain**: In contrast, the SI channel estimation and signal processing for cancelling SI becomes relatively easy in digital domain [7], [8]. This is due to the flexibility of the digital hardware and algorithms. However, the digital-domain cancellation is limited by the ADC’s dynamic range leading to clipping errors and large quantization noise, as introduced in the first paragraph.

Our work is based on the latter, and more prevalent approach of digital domain SI cancellation. In this context, so that we can simultaneously tackle the ADC saturation and quantization noise issues, we propose to use Unlimited Sensing Framework (USF). In summary, instead of using conventional ADCs, we use modulo ADCs or \mathcal{M}_λ -ADCs at the core of the USF [10]–[12]. We develop a fully digital-domain SI cancellation and propose a full-stack, FD receiver architecture design stemming from the use of modulo ADCs. It considers the digital signal processing, *i.e.* “inversion” of the modulo non-linearity, channel estimation, digital SIC, and signal detection. Recently, we have proposed a receiver architecture design for Massive MIMO systems [12] that is based on the USF. Similar to that case, our approach here does not employ any analog-domain SIC circuitry, AGC and VGA, resulting in a low hardware complexity. Distinguished from [12], our design considers FD case, thus it encompasses new aspects of modulo-domain sparse channel estimation and digital SIC. This is elaborated in the contributions. We validate our approach through simulations and show its superiority over recent approach. Specifically, our method can achieve 40 dB digital SIC with as little as 4-bit quantization resolution.

Contributions. Our main contributions are as follows:

- **Theoretical front.** We propose a *full-stack* FD receiver architecture design, which can handle HDR signals and achieve higher quantization resolution with a given budget. The *full-stack* design in this paper enables understanding of the trade-off between bit-budget and dynamic range, and the best achievable digital SI cancellation capability.
- **Algorithmic front.** We present recovery algorithms for the

The authors are with the Dept. of Electrical and Electronic Engg., Imperial College London, SW7 2AZ, UK. (e-mails: {ziang.liu20, a.bhandari, b.clerckx}@imperial.ac.uk).

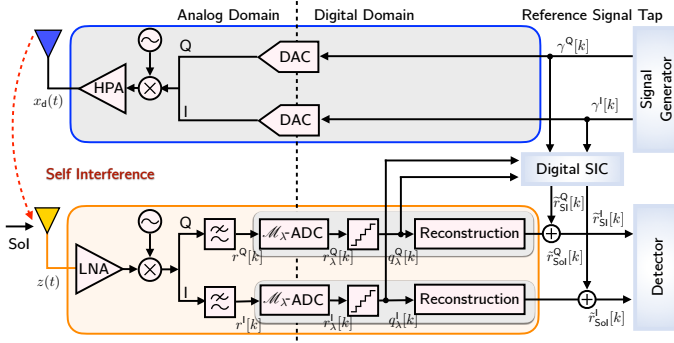

Fig. 1. FD model with modulo-domain channel estimation method and digital cancellation based on \mathcal{M}_λ -ADC.

FD case. Additionally, we also propose a novel modulo-domain sparse channel estimation method, resulting in a more accurate digital SI cancellation compared with previous methods [13].

- **Hardware front.** Since our approach is devoid of any analog-domain SIC circuitry, *e.g.* AGC and VGA, it lends itself to a low complexity implementation.

Ordonez & co-workers were early to identify the benefits of modulo non-linearities for combating receiver saturation in a FD setup [13]. Their work presents a systematic analysis of “Modulo FD Transceiver” inspiring new architectures in the field. Their scope, however, does not consider full-stack FD architecture or the recovery problem discussed in this paper. Both these aspects are relevant and timely for realization of a fully digital-domain FD system design. Compared to [13], our work has fundamental differences as a) we propose a novel full-stack FD receiver design; b) we propose a modulo-domain channel estimation algorithm and provide a theorem for ensuring the success of the algorithm; c) we consider the case of low-resolution quantization (*e.g.* 4-bit).

II. SYSTEM MODEL

The FD communication system we consider is shown in Fig. 1. The baseband signals, $\gamma^Q[k]$ and $\gamma^I[k]$, are pulse-shaped and up-converted to form the passband signal, $x_d(t)$. The FD transceiver simultaneously serves an uplink and a downlink user. The received antenna signal is given by

$$z(t) \stackrel{\text{def}}{=} \underbrace{(h_u *_{\mathcal{T}} x_u)}_{\text{SoI}} + \underbrace{(h_{\text{SI}} *_{\mathcal{T}} x_d)}_{\text{SI}} + n(t), \quad (1)$$

- $*_{\mathcal{T}}$ is the semi-discrete convolution operator with sampling interval T and some sequence $c \in \ell^2$, defined by [14]

$$*_{\mathcal{T}} : c \mapsto (c *_{\mathcal{T}} \phi)(t) = \sum_{n \in \mathbb{Z}} c[n] \phi(t - kT).$$

- h_u and h_{SI} are the discrete uplink and SI channels in the FD system, respectively.
- $x_u(t)$ and $x_d(t)$ are the pulse-shaped continuous-time uplink signal and downlink signal, respectively.
- $n(t) \sim \mathcal{CN}(0, 1)$ is the additive complex-Gaussian noise at the receiver.

Subsequently, the received signal enters the RF chain and is processed by the \mathcal{M}_λ -ADC at the quadrature and in-phase

channels, respectively. As shown in Fig. 1, we design a novel RF chain, signal processing blocks for SoI reconstruction, digital SIC, and detection.

Receiver. Compared with conventional receiver architecture for FD system, our novel receiver deploys a \mathcal{M}_λ -ADC to simultaneously prevent drowning of SoI caused by the saturation due to the limited dynamic range, and reduce quantization noise. Specifically, the continuous-time baseband signal for I/Q channels, $r^Q(t)$ and $r^I(t)$, are first folded with modulo threshold $\lambda > 0$ by the \mathcal{M}_λ -ADC hardware [15]. Since, i) the modulo signal $r(t)$ is bounded by λ (in absolute sense), no VGA and AGC [16] is needed, and ii) there is no requirement for analog-domain SIC circuitry, our approach results in a lower hardware complexity. The continuous-time modulo-folded signal is sampled and quantized, resulting in,

$$r(t) \xrightarrow{\text{Folding}} \boxed{\mathcal{M}_\lambda} \rightarrow r_\lambda[k] \xrightarrow{b \text{ Bits}} \boxed{\mathcal{Q}_b} \rightarrow q_\lambda[k] = \mathcal{Q}_b(r_\lambda[k]) \quad (2)$$

where $\mathcal{M}_\lambda(\cdot)$ [12], [17] is the centered-modulo operator producing modulo samples, $r_\lambda[k] \stackrel{\text{def}}{=} \mathcal{M}_\lambda(r(t))|_{t=kT}$ and \mathcal{Q}_b is the quantization operator with bit budget of b bits. These quantized samples $q_\lambda[k]$ enable the reconstruction of the SI r_{SI} , and thus we can achieve SIC by subtracting it from the received signal r .

Recovery from folded samples. To reconstruct the HDR input signal, $r(t)$, from its modulo samples, an “inversion” of modulo non-linearity $\mathcal{M}_\lambda(\cdot)$ is needed. The key to unfolding the modulo samples is based on the observation that the finite difference operator commutes with the modulo in some sense [11]. This allows us to obtain the higher-order differences of r from its modulo samples, r_λ . Thus, the reconstruction amounts to the problem of stably inverting the difference-operator.

Let us define the L^{th} order finite difference of the sequence $x[k]$ by the recursion, $(\Delta^L x)[k] = \Delta^{L-1}(\Delta x)[k]$, $L > 1$. When $L = 1$, we define $\underline{x}[k] = (\Delta x)[k] = x[k+1] - x[k] \iff \underline{\mathbf{x}} = \Delta \mathbf{x}$. Specifically, according to the unlimited sampling theorem with bounded noise [11], oversampling $r(t) \in \mathcal{B}_\Omega$ with $T \leq 1/2^\alpha \Omega e$, where $\alpha \in \mathbb{N}$, Ω is the bandwidth, and e is the Euler’s number, allows us to access the L^{th} order difference, $\Delta^L r$, from its modulo samples $r_\lambda[k]$. A suitable L can be $L^* \geq \left\lceil \frac{\log \lambda - \beta_r}{\log(T\Omega e)} \right\rceil$ with $\beta_r \in 2\lambda\mathbb{Z}$ and $\beta_r \geq \|r\|_\infty$. To stably invert the difference operator, we use the anti-difference operation \mathcal{S} , defined by $\mathcal{S} : \{s[k]\}_{k \in \mathbb{Z}^+} \rightarrow \sum_{m=1}^k s[m]$. Instead of recovering r via anti-difference operation \mathcal{S} , we capitalize the piece-wise constant structure of the residue $\varepsilon_r(t) = r(t) - \mathcal{M}_\lambda(r(t))$, that is, $\Delta^L \varepsilon_r(kT) \in 2\lambda\mathbb{Z}$, to reconstruct the unfolded signal. We conclude the reconstruction approach is summarized in Algorithm 1 which also works with quantized measurements [11].

Modulo-domain channel estimation and digital SIC. To achieve a full-stack fully digital-domain SIC FD system, we propose a modulo-domain channel estimation method to estimate SI channel, h_{SI} , as in Algorithm 2. In addition, we design a corresponding digital SIC approach based on \mathcal{M}_λ -ADC, inspired by [18], [19]. Since the received signal can be acquired without saturation, and it incorporates SI and SoI as

Algorithm 1 Recovery from Noisy Modulo Samples

Input: $q_\lambda[k]$ and $2\lambda\mathbb{Z} \ni \beta_r \geq \|r\|_\infty$.

Output: $\tilde{r}[k] \approx r(kT)$.

- 1) Compute $L = \left\lceil \frac{\log \lambda - \log \beta_r}{\log(T\Omega e)} \right\rceil$.
 - 2) Compute $(\Delta^L q_\lambda)[k]$.
 - 3) Compute $(\Delta^L \varepsilon_r)[k] = (\mathcal{M}_\lambda(\Delta^L q_\lambda) - \Delta^L q_\lambda)[k]$.
Set $s^{\{0\}}[k] = (\Delta^L \varepsilon_r)[k]$
 - for** $l = 0 : L - 2$ **do**
 - i) $s^{\{l+1\}}[k] = (\mathbf{S}s^{\{l\}})[k]$
 - ii) $s^{\{l+1\}} = 2\lambda \left\lceil \frac{\lfloor s^{\{l+1\}}/\lambda \rfloor}{2} \right\rceil$ (rounding to $2\lambda\mathbb{Z}$)
 - iii) Compute $\kappa^{\{l\}} = \left\lfloor \frac{(\mathbf{S}^2 \Delta^l \varepsilon_r)[1] - (\mathbf{S}^2 \Delta^l \varepsilon_r)[J_\lambda + 1]}{12\beta_r} + \frac{1}{2} \right\rfloor$
 - iv) $s^{\{l+1\}}[k] = s^{\{l+1\}}[k] + 2\lambda\kappa^{\{l\}}$
 - end for**
 - 5) $\tilde{r}[k] = \mathbf{S}(s_{\{L-1\}})[k] + q_\lambda[k] + 2v\lambda, v \in \mathbb{Z}$
-

given in (1), our aim is to reconstruct SI via our proposed approach and subtract it from the received signal.

Specifically, in the proposed modulo-domain channel estimation method, a pilot is firstly transmitted, and we assume no SoI is transmitted during the SI channel estimation period. Considering a single path SI channel, h_{SI} , with delay, τ , and amplitude, A , the SI channel is hence modelled as $h_{\text{SI}}[k] = A\delta[k - \tau]$. After down-conversion, the pointwise received SI samples are given by

$$r_{\text{SI}}[k] = A\gamma[k - \tau] = \sum_{|p| \leq P} (\hat{\gamma}_p \hat{h}_{\text{SI}}) e^{j p \omega_0 k}, \quad (3)$$

where γ is a T_p -periodic baseband transmit signal (reference signal, cf. transmitter in Fig. 1), $\hat{h}_{\text{SI}} = Ae^{-j p \omega_0 \tau}$, $P = \lceil \Omega/\omega_0 \rceil$, $\omega_0 = 2\pi/T_p$, and $K \geq 2P + 1$. Additionally, $\hat{\gamma}_p$ is the Fourier series (FS) coefficient and $\hat{\gamma}_{-p} = \hat{\gamma}_p^*$. We then have the bandlimitedness that is $\hat{\gamma}_p = 0, |p| > P = \lceil \Omega/\omega_0 \rceil$ denoted by $f \in \mathcal{B}_\Omega$. In vector-matrix format, (3) is given by

$$\mathbf{r}_{\text{SI}} = \mathbf{U}^* \mathcal{D}_{\hat{\gamma}} \hat{\mathbf{h}}_{\text{SI}}, \quad (4)$$

- $\mathbf{r}_{\text{SI}} \in \mathbb{R}^{K \times 1}$ is the samples with $[\mathbf{r}_{\text{SI}}]_k = r_{\text{SI}}(kT)$.
- $\mathbf{U} \in \mathbb{C}^{K \times (2P+1)}$ is the Discrete Fourier Transform (DFT) matrix with element $[\mathbf{U}]_{k,p} = e^{-j p \omega_0 k T}$.
- $\mathcal{D}_{\hat{\gamma}}$ is the matrix of FS coefficients. It is a diagonal matrix and the FS coefficients of the kernel (transmit signal), γ , are on the diagonal, i.e. $[\mathcal{D}_{\hat{\gamma}}]_{p,p} = \hat{\gamma}_p$.
- $\hat{\mathbf{h}}_{\text{SI}} \in \mathbb{C}^{(2P+1) \times 1}$ is a vector of exponentials parameterized by the unknown channel, i.e. $[\hat{\mathbf{h}}_{\text{SI}}]_p = \hat{h}_{\text{SI},p}$.

In our case, the forward model takes the form of,

$$\mathbf{r}_{\text{SI},\lambda} = \mathcal{M}_\lambda(\mathbf{U}^* \mathcal{D}_{\hat{\gamma}} \hat{\mathbf{h}}_{\text{SI}}) \in \mathbb{R}^{K \times 1}, \quad (5)$$

and the goal is to estimate \mathbf{r}_{SI} in (4).

Estimation Procedure. Starting from the modulo decomposition property, we have

$$\mathbf{r}_{\text{SI},\lambda} = \mathbf{r}_{\text{SI}} - \varepsilon_{\text{SI}} \xrightarrow{\Delta} \mathbf{r}_{\text{SI},\lambda} = \mathbf{r}_{\text{SI}} - \varepsilon_{\text{SI}}, \quad \mathbf{r}_{\text{SI}} = \Delta \mathbf{r}_{\text{SI}} \quad (6)$$

where Δ is the finite difference operator yielding, $[\Delta \mathbf{r}_{\text{SI}}]_k = [\mathbf{r}_{\text{SI}}]_{k+1} - [\mathbf{r}_{\text{SI}}]_k$. We use $\mathbb{I}_K = \{0, \dots, K-1\}$, $K \in \mathbb{Z}^+$ to denote the set of K contiguous integers, and $\mathbb{E}_{P,K} = [0, P] \cup$

Algorithm 2 Modulo-domain Sparse Channel Estimation

Input: $\{r_{\text{SI}}[k], r_{\text{SI},\lambda}[k]\}_{k=0}^{K-1}$, T_p , and P .

Output: h_{SI} .

- 1) Compute $\hat{\mathbf{r}}_{\text{SI},\lambda} = \mathbf{V} \mathbf{r}_{\text{SI},\lambda}$ (DFT).
 - 2) Define $[\mathbf{z}]_n = -[\hat{\mathbf{r}}_{\text{SI},\lambda}]_n, n \in \mathbb{I}_{K-1} \setminus \mathbb{E}_{P,K-1}$.
 - 3) Estimate number of folds, M , by forming a Toeplitz or Hankel matrix from $[\mathbf{z}]_n$ [18] and then thresholding using *second order statistic* of eigenvalues [20].
 - 4) Estimate folds using Prony(\mathbf{z}) $\mapsto (\{\mu_m, \nu_m\}_{m=0}^{M-1}, \mathbf{f})$.
 - 5) Construct $\hat{\varepsilon}_r$ for $n \in [0, K-2]$.
 - 6) Estimate $[\hat{\mathbf{r}}_{\text{SI}}]_n = [\hat{\mathbf{r}}_{\text{SI},\lambda}]_n + [\hat{\varepsilon}_r]_n, n \in \mathbb{E}_{P,K-1}$.
 - 7) Calculate $\hat{\gamma}$ with given reference signal γ . Compute element-wise division that is $\mathbf{d} = \hat{\mathbf{r}}_{\text{SI}}/\hat{\gamma}$, where $[\mathbf{d}]_n = e^{-j\omega_0 \tau} [\mathbf{d}]_{n-1}$.
 - 8) Calculate $q \triangleq ([\mathbf{d}]_n - [\mathbf{d}]_{n+1})/([\mathbf{d}]_{n-1} - [\mathbf{d}]_n)$.
 - 9) Compute $\tilde{\tau} = -K \arctan(q)/(2\pi)$, $A = \mathcal{E}(|\mathbf{d}|)$, and $h_{\text{SI}} = A\delta(k - \tilde{\tau})$.
 - 10) Reconstruct $r_{\text{SI}} = h_{\text{SI}} * \gamma$ and subsequently subtract it from the received signal (r)
-

$[K-P, K-1], |\mathbb{E}_{P,K}| = 2P+1$ to denote the effective spectrum. Applying the DFT on (6) results in,

$$\mathbf{V} \mathbf{r}_{\text{SI},\lambda} = \mathbf{V} \mathbf{r}_{\text{SI}} - \mathbf{V} \varepsilon_{\text{SI}}, \quad [\mathbf{V}]_{n,k} = e^{-j(\frac{2\pi}{K-1})nk}, k \in \mathbb{I}_{K-1} \quad (7)$$

where $\mathbf{V} \in \mathbb{C}^{(K-1) \times (K-1)}$ is the DFT matrix. Noting that $\mathbf{V} \mathbf{r}_{\text{SI}}$ is the contribution due to the bandlimited part, choosing $n \in (\mathbb{I}_{K-1} \setminus \mathbb{E}_{P,K-1}) + (K-1)\mathbb{Z}$ provides us with access to the modulo folds, which in the DFT domain assume a parametric form. In particular, $\forall n \in (\mathbb{I}_{K-1} \setminus \mathbb{E}_{P,K-1}) + (K-1)\mathbb{Z}$, $\mathbf{V} \mathbf{r}_{\text{SI},\lambda} = -\mathbf{V} \varepsilon_{\text{SI}} = \sum_{m=0}^{M-1} \mu_m e^{-j(\frac{2\pi}{K-1})\frac{n}{T} \nu_m}$ is sum-of-complex-exponentials [18], [19] which can be estimated via Prony's method [21]. We denote this procedure by, Prony(\mathbf{z}) $\mapsto (\{\mu_m, \nu_m\}_{m=0}^{M-1}, \mathbf{f})$ where $\mathbf{z} = -\mathbf{V} \varepsilon_{\text{SI}}, \forall n \in (\mathbb{I}_{K-1} \setminus \mathbb{E}_{P,K-1})$.

With $\hat{\varepsilon}_{\text{SI}}$ known, we can remove its contribution and obtain $\hat{\mathbf{r}}_{\text{SI}} = \hat{\mathbf{r}}_{\text{SI},\lambda} + \hat{\varepsilon}_{\text{SI}}$. Instead of recovering the signal \mathbf{r}_{SI} , we follow a direct Fourier domain deconvolution approach to estimate h_{SI} . To this end, note that,

$$\forall n \in (\mathbb{E}_{P,K-1}) + (K-1)\mathbb{Z}, \quad \hat{r}_{\text{SI}}[n] = \hat{\gamma}[n] A e^{-j\omega_0 n \tau} \quad (8)$$

The process of deconvolution now entails point-wise division,

$$d[n] \triangleq \frac{\hat{r}_{\text{SI}}[n]}{\hat{\gamma}[n]} = A e^{-j\omega_0 n \tau} \equiv \hat{h}_{\text{SI}}[n]. \quad (9)$$

With $[\mathbf{d}]_n = d[n]$, we can now estimate $A = |\mathbf{d}|$ and more generally, via $\mathcal{E}(|\mathbf{d}|)$, where \mathcal{E} denotes expectation operator. The unknown delay is estimated via,

$$[\mathbf{d}]_n/[\mathbf{d}]_{n-1} = e^{-j\omega_0 \tau} \Rightarrow \tau = \frac{1}{-j\omega_0} \angle([\mathbf{d}]_n/[\mathbf{d}]_{n-1}). \quad (10)$$

Furthermore, one may leverage measurement redundancy to obtain a robust estimate via least-squares solution. The procedural steps are outlined in Algorithm 2.

Having estimated h_{SI} via the proposed modulo-domain channel estimation method, we can reconstruct r_{SI} and subsequently subtract it from the received signal (r), to obtain the SoI, r_{SoI} .

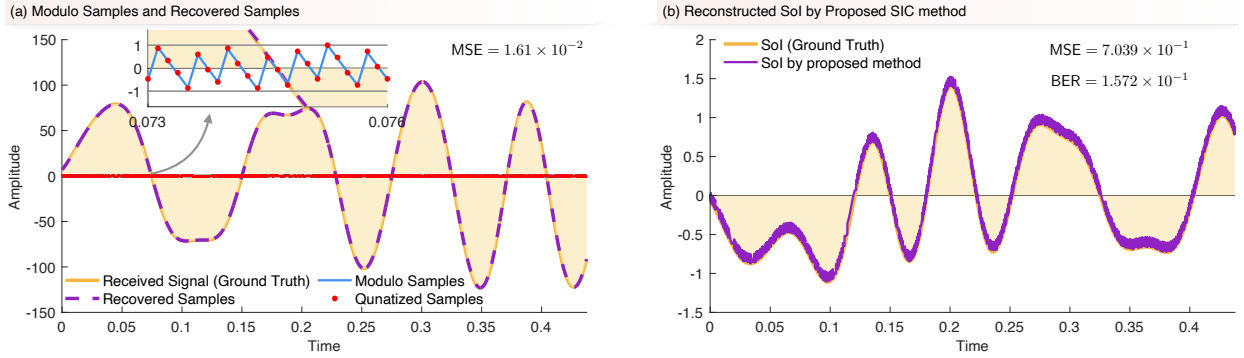

Fig. 2. Simulation results with 4-bit quantization, $1/\text{SIR} = 40$ dB, and $\text{SNR} = 40$ dB of (a) modulo samples and recovery; (b) SoI reconstruction by our proposed SIC approach.

Recovery Condition: For Algorithm 2 to succeed, the exponential fitting part (*i.e.* Prony's method) in step 2 requires

$$K \geq 2(P + M + 1)$$

while step 8 (see (10)) requires that $P \geq 1$. With the period $\tau = KT$, the recovery condition thus is, $T \leq \frac{\tau}{2M+4}$ with $P = \lceil \frac{\Omega}{\omega_0} \rceil \geq 1$, resulting the following theorem.

Theorem 1 (Modulo-domain Channel Estimation). *Let $g = h_{S1} * \gamma$ where $h_{S1}(t) = A\delta(t - t_\tau)$ is the unknown 1-sparse channel, and $\gamma \in \mathcal{B}_\Omega$ is a known, T_p -periodic, transmitted signal. Given K modulo samples $g_\lambda[k] = \mathcal{M}_\lambda(g(kT))$, $T > 0$ folded at most M times, the sufficient condition for estimation of h_{S1} from $\{g_\lambda[k]\}_{k=0}^{K-1}$ is that $T \leq \frac{T_p}{K}$ and $K \geq 2(M + 2)$.*

III. NUMERICAL EVALUATION

This section focuses on the unique advantages of adopting the USF for full-stack FD architecture. According to the simulations, we show the saturation-free recovered (received) signal, reconstructed SoI and detection performance. We consider single-carrier quadrature phase shift keying (QPSK) based transmission, and the SI channel is modelled as a single path channel with delay. Additionally, the SI power is measured by $\text{SIR} = 10 \log_{10}(P_{\text{SoI}}/P_{\text{S1}})$ dB. We assume that no uplink data is transmitted during the SI channel estimation period, and perfect CSI of the uplink channel is known at the receiver. With respect to the recovery algorithm, we follow $f_s \geq 2\pi e f_{\text{Nyquist}}$ to reconstruct the signal in the simulation. We remind the reader that this is a loose bound, a near Nyquist-rate recovery is also possible [22], specially with some side-information [23], which is not assumed in this paper.

Recovery of received signal and SoI after SIC. Since we consider the FD system, it is natural to work with signals such that $\|r\|_\infty \triangleq \max |r(t)| \gg \lambda$. To prevent saturation, the received signal is folded by the \mathcal{M}_λ -ADCs. Subsequently, modulo-domain channel estimation as in Algorithm 2 is adopted to estimate SI channel, h_{S1} . Then, the unfolded received signal \tilde{r} is recovered from the modulo samples r_λ . With the estimated SI channel and baseband transmit signal γ (reference signal), the digital-domain SIC is applied. Specifically, we reconstruct the SI signal r_{S1} , and subtract it

from the reconstruction of the received signal \tilde{r} to obtain r_{SoI} . Finally, the QPSK signal detection is executed on the r_{SoI} .

As shown in Fig. 2, considering low-resolution quantization (*i.e.* $b = 4$) with $1/\text{SIR} = 40$ dB (*e.g.* $\lambda = 1, \|r\|_\infty = 141.1621$), and $\text{SNR} = 40$ dB, the reconstruction error of the received signal is $\text{MSE} = 1.61 \times 10^{-2}$. The reconstruction error of the SoI is $\text{MSE} = 7.039 \times 10^{-1}$. The bit error rate (BER) is 1.572×10^{-1} . If we consider a smaller SI power that is $1/\text{SIR} = 20$ dB, and keep other simulation parameters fixed, the following results are obtained. The reconstruction error of the received signal is $\text{MSE} = 1.17 \times 10^{-2}$. The reconstruction error of the SoI is $\text{MSE} = 3.47 \times 10^{-2}$. The bit error rate (BER) is 7.47×10^{-2} . We attribute the reconstruction with few bits to the fact that for a given bit budget, the \mathcal{M}_λ -ADC offers a higher signal to quantization noise ratio (SQNR). With the definition of ratio $\zeta \triangleq \lambda/\|r\|_\infty$, it is shown that a $20 \log_{10}(1/\zeta)$ dB enhancement in the SQNR [12]. In contrast, adaptive filter based strategies [13] are not feasible as they can not handle modulo samples, and hence, the SoI reconstruction and detection fail in the simulations.

IV. CONCLUSION

In this work, we presented a method for full-stack FD receiver architecture, utilizing the unlimited sensing framework. We demonstrated the advantages of substituting the traditional analog-to-digital Converter (ADC) with a modulo ADC (\mathcal{M}_λ -ADC). This replacement effectively avoids ADC saturation, enabling the capture of high dynamic range signals. Additionally, the low quantization noise feature of the \mathcal{M}_λ -ADC allows for the use of few-bits quantization. The use of \mathcal{M}_λ -ADC necessitated the creation of algorithms for sparse channel estimation. To address this, we introduced a novel approach for sparse channel estimation in the modulo domain, accompanied by a digital SI cancellation method. Our numerical results demonstrate that the proposed full-stack FD receiver structure can tackle with very strong SI (*e.g.* 40 dB) with few-bits quantization, and outperforms the previous approach in terms of SoI reconstruction, digital SIC, and detection performance. To summarize, our work enables: 1) fully digital-domain SI cancellation in FD system; 2) modulo-domain sparse channel estimation; 3) a low complexity implementation of FD system due to no VGA, AGC and analog-domain SIC circuitry.

REFERENCES

- [1] P. Yang, Y. Xiao, M. Xiao, and S. Li, "6G wireless communications: Vision and potential techniques," *IEEE Netw.*, vol. 33, no. 4, pp. 70–75, 2019.
- [2] A. Sabharwal, P. Schniter, D. Guo, D. W. Bliss, S. Rangarajan, and R. Wichman, "In-band full-duplex wireless: Challenges and opportunities," *IEEE J. Sel. Areas Commun.*, vol. 32, no. 9, pp. 1637–1652, 2014.
- [3] K. E. Kolodziej, B. T. Perry, and J. S. Herd, "In-band full-duplex technology: Techniques and systems survey," *IEEE Trans. Microw. Theory Techn.*, vol. 67, no. 7, pp. 3025–3041, 2019.
- [4] Z. Zhang, K. Long, A. V. Vasilakos, and L. Hanzo, "Full-duplex wireless communications: Challenges, solutions, and future research directions," *Proc. IEEE*, vol. 104, no. 7, pp. 1369–1409, 2016.
- [5] B. Debaillie, D.-J. van den Broek, C. Lavin, B. van Liempd, E. A. Klumperink, C. Palacios, J. Craninckx, B. Nauta, and A. Pärssinen, "Analog/RF solutions enabling compact full-duplex radios," *IEEE J. Sel. Areas Commun.*, vol. 32, no. 9, pp. 1662–1673, 2014.
- [6] D. Korpi, J. Tamminen, M. Turunen, T. Huusari, Y.-S. Choi, L. Anttila, S. Talwar, and M. Valkama, "Full-duplex mobile device: Pushing the limits," *IEEE Commun. Mag.*, vol. 54, no. 9, pp. 80–87, 2016.
- [7] D. Bliss, P. Parker, and A. Margetts, "Simultaneous transmission and reception for improved wireless network performance," in *IEEE/SP 14th Workshop on Statistical Signal Processing*. IEEE, 2007, pp. 478–482.
- [8] P. Lioliou, M. Viberg, M. Coldrey, and F. Athley, "Self-interference suppression in full-duplex MIMO relays," in *2010 Conference Record of the Forty Fourth Asilomar Conference on Signals, Systems and Computers*. IEEE, 2010, pp. 658–662.
- [9] M. Duarte, C. Dick, and A. Sabharwal, "Experiment-driven characterization of full-duplex wireless systems," *IEEE Trans. Wireless Commun.*, vol. 11, no. 12, pp. 4296–4307, Dec. 2012.
- [10] A. Bhandari, F. Kraemer, and R. Raskar, "On unlimited sampling," in *Intl. Conf. on Sampling Theory and Applications (SampTA)*, Jul. 2017.
- [11] —, "On unlimited sampling and reconstruction," *IEEE Trans. Sig. Proc.*, vol. 69, pp. 3827–3839, Dec. 2020.
- [12] Z. Liu, A. Bhandari, and B. Clerckx, " λ -MIMO: Massive MIMO via modulo sampling," *IEEE Trans. Commun.*, vol. 71, no. 11, pp. 6301–6315, 2023.
- [13] L. G. Ordóñez, P. Ferrand, M. Duarte, M. Guillaud, and G. Yang, "On full-duplex radios with modulo-ADCs," *IEEE Open J. of the Comm. Society.*, vol. 2, pp. 1279–1297, 2021.
- [14] A. Bhandari and A. I. Zayed, "Shift-invariant and sampling spaces associated with the fractional fourier transform domain," *IEEE Trans. Sig. Proc.*, vol. 60, no. 4, pp. 1627–1637, 2011.
- [15] A. Bhandari, F. Kraemer, and T. Poskitt, "Unlimited sampling from theory to practice: Fourier-Prony recovery and prototype ADC," *IEEE Trans. Sig. Proc.*, vol. 70, pp. 1131–1141, Sep. 2021.
- [16] C. K. Sheemar and D. Slock, "Receiver design and AGC optimization with self interference induced saturation," in *ICASSP 2020-2020 IEEE International Conference on Acoustics, Speech and Signal Processing (ICASSP)*. IEEE, 2020, pp. 5595–5599.
- [17] A. Bhandari, M. H. Conde, and O. Loffeld, "One-bit time-resolved imaging," *IEEE Trans. Pattern Anal. Mach. Intell.*, vol. 42, no. 7, pp. 1630–1641, Jul. 2020.
- [18] A. Bhandari, F. Kraemer, and T. Poskitt, "Unlimited sampling from theory to practice: Fourier-Prony recovery and prototype ADC," *IEEE Trans. Sig. Proc.*, vol. 70, pp. 1131–1141, 2021.
- [19] A. Bhandari, "Back in the US-SR: Unlimited sampling and sparse super-resolution with its hardware validation," *IEEE Signal Process. Lett.*, vol. 29, pp. 1047–1051, 2022.
- [20] Z. He, A. Cichocki, S. Xie, and K. Choi, "Detecting the number of clusters in n-way probabilistic clustering," *IEEE Trans. Pattern Anal. Mach. Intell.*, vol. 32, no. 11, pp. 2006–2021, 2010.
- [21] P. Stoica, "List of references on spectral line analysis," *Signal Processing*, vol. 31, no. 3, pp. 329–340, 1993.
- [22] A. Bhandari and F. Kraemer, "On identifiability in unlimited sampling," in *2019 13th International conference on Sampling Theory and Applications (SampTA)*. IEEE, 2019, pp. 1–4.
- [23] O. Ordentlich, G. Tabak, P. K. Hanumolu, A. C. Singer, and G. W. Wornell, "A modulo-based architecture for analog-to-digital conversion," *IEEE J. Sel. Topics Signal Process.*, vol. 12, no. 5, pp. 825–840, 2018.