

Towards a Robust Soft Baby Robot With Rich Interaction Ability for Advanced Machine Learning Algorithms

Mohannad Alhakami,^{1,2} Dylan R. Ashley,^{*3,4,5,6} Joel Dunham,^{*7} Francesco Faccio,^{3,4,5,6}
Eric Feron,¹ and Jürgen Schmidhuber^{3,4,5,6,8}

Abstract—Artificial intelligence has made great strides in many areas lately, yet it has had comparatively little success in general-use robotics. We believe one of the reasons for this is the disconnect between traditional robotic design and the properties needed for open-ended, creativity-based AI systems. To that end, we, taking selective inspiration from nature, build a robust, partially soft robotic limb with a large action space, rich sensory data stream from multiple cameras, and the ability to connect with others to enhance the action space and data stream. As a proof of concept, we train two contemporary machine learning algorithms to perform a simple target-finding task. Altogether, we believe that this design serves as a first step to building a robot tailor-made for achieving artificial general intelligence.

I. INTRODUCTION

From generative artificial intelligence for text (e.g., ChatGPT [1]) and images (e.g., Dall-E [2], [3], [4]), to protein folding [5], circuit design [6], navigation of high-altitude balloons [7], controlling plasma in a tokamak reactor [8], and achieving grandmaster level in Starcraft II [9] recent years have seen a slew of breakthroughs in AI—all of which leveraged powerful algorithms (e.g., deep reinforcement learning with policy gradients [10], [11]) and large-scale simulations. Absent from the above list, however, is robotics, a realm in which high-fidelity, large-scale simulation is impossible. While low-fidelity simulators have led AI to have some success in dexterous control of a robotic hand [12] and similar settings, the general-purpose problem-solving ability that is the goal of many in this field continues to be evasive.

We believe the problem lies in the unsuitability of traditional robotic setups to include state-of-the-art machine learning algorithms. General purpose problem solving with AI in robotics demands creative, open-ended AI algorithms, which require rich interaction ability with their environment and complex neural networks to manage this interaction. However, in practice, the long constant operation of the robot needed when training an artificial neural network is often composed of small random movements alongside sub-optimal and destructive learned behaviour [13], [14]. This behaviour is typically fatal to sufficiently complex robots that have such rich data streams.

^{*}Equal contribution. ¹Robotics, Intelligent Systems, and Control Lab, King Abdullah University of Science and Technology (KAUST), Saudi Arabia. ²Saudi Basic Industries Corporation (SABIC), Saudi Arabia. ³AI Initiative, King Abdullah University of Science and Technology (KAUST), Saudi Arabia. ⁴Dalle Molle Institute for Artificial Intelligence Research (IDSIA), Switzerland. ⁵Università della Svizzera italiana (USI), Switzerland. ⁶Scuola universitaria professionale della Svizzera italiana (SUPSI), Switzerland. ⁷optoXense, Inc., United States of America. ⁸NNAISENSE, Switzerland. Correspondence to mohannad.alhakami@kaust.edu.sa

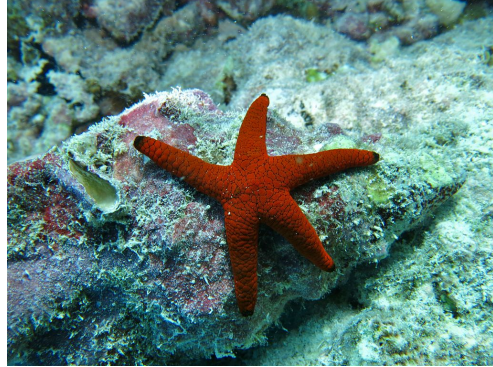

Frédéric Ducarme, CC BY-SA 4.0 <https://creativecommons.org/licenses/by-sa/4.0/>, via Wikimedia Commons

(a) The principal inspiration for the design.

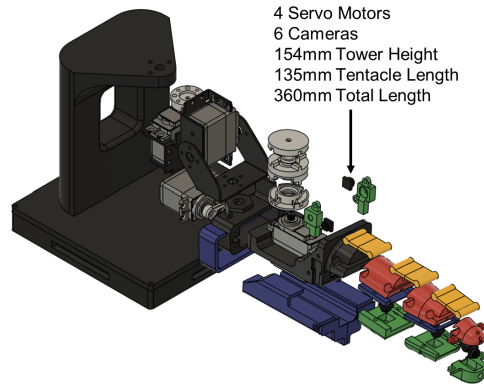

(b) The final limb design.

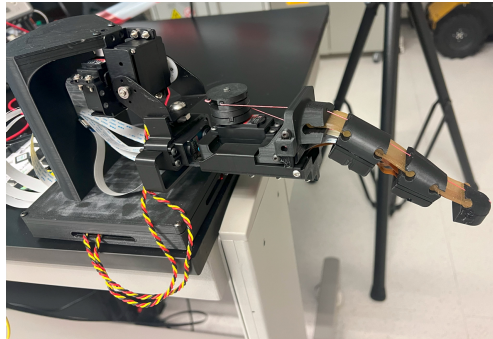

(c) The constructed limb.

Fig. 1: The design of the limb we construct is loosely inspired by the shape of a starfish in that we envision a multi-limbed headless creature with the bulk of the sensors being contained in the limbs themselves.

To take a step towards resolving the aforementioned issues, we design and build a robust robotic manipulator outfitted with many cameras and several actuators (see Figure 1). The manipulator takes inspiration from biology and has soft joints in between limb segments, each of which is equipped with one or more cameras. The use of cameras as the principal sensor replaces the functionality of touch sensors, which are particularly prone to wear and tear. As proof that this can be used for machine learning work, we run a small target-finding experiment using a state-of-the-art deep reinforcement learning algorithm (Proximal Policy Optimization) and a more classical algorithm in robotic control (Actor-Critic). In both instances, we show that these algorithms are able to converge to optimal or near-optimal policies, all with minimal human supervision of the robot, despite extended runtimes.

Owing to the necessity of designing and building a very resilient machine suitable for learning experiments over extended periods of time, we chose Model-Based Systems Engineering (MBSE) to handle the soft robot’s complex interrelationships. Through MBSE, the soft robot has the opportunity to understand its own dynamics, enabling the learning robot to improve itself eventually. Systems Modeling Language (SysML) version 2 (v2) [15] uses a programming-type language to encode these relationships, enabling the robotic brain to eventually understand and modify itself. Relationships in the SysML v2 model enable predicting issues before building the robot hardware and then improving the model based on test outcomes. We have already incorporated lessons learnt through multiple iterations.

While significant, the development of this limb serves as an intermediate step towards a more complete robot. We envision the final version as something like a six-limbed starfish, with each limb equipped with several actuators and many cameras. In contrast to a version of this with a head, such as an octopus-inspired design might have, the flat starfish design reduced the possibility of the robot trapping itself while learning.

II. BACKGROUND AND RELATED WORK

Robotics has played a pivotal role in the development and popularization of reinforcement learning (RL), with many key achievements ranging from autonomous inverted helicopter flight [16] to control of a complex robotic hand [12]. RL is thought to be most useful in learning a mapping from sensory and cognitive processes to movement, i.e., *sensory-motor learning* [17], [18], [19], [20]. Two particularly active areas of research for RL in robotics are in learning a predictive knowledge framework [21], [22], and for planning and control [23]. In the predictive knowledge framework in robotics, one of the most inspirational applications of RL is in prediction (e.g., [24]) and control (e.g., [25]) of prosthetic limbs [26], [27], [28], [29]. Today’s AI-driven robotics environment is driven by relatively simple robot design requirements, e.g., a humanoid robot might be designed to demonstrate the AI’s ability to meet a specific skill, such as playing basketball. Many designs inspired by nature are

likewise restricted to particular applications (e.g., a spider for mobility, an octopus for manipulation, or a humanoid for combining mobility and manipulation).

The design question to be answered—“What hardware attributes should a learning baby robot have in order to properly capture a large class of such systems?”—call upon the more recent research in incorporating flexibility in system design [30]. Systems engineering principles were used to support an early attempt at defining the architecture of learning baby robots [31], [32]. Inspired by Turing’s “Child Machine” [33], traditional robots are constructed from rigid materials. These materials, while aiding in repeatable and precise behavior, are susceptible to physical damage, especially on joints: bending or misaligned jeopardizes the robot’s behavior. Physical damage resistance can be improved by using soft robots even though there is a loss in dexterity and power [34]. A scenario that is more favourable for us is a hybrid between rigid and soft components, where we replace the joints with compliant soft materials. Yale soft hand is an example—a community-driven, low-cost robot using a hybrid manufacturing requirement where 3D printed components are reinforced with soft, casted materials [35].

III. SYSTEMS ENGINEERING

Model-Based Systems Engineering (MBSE) is increasingly used to develop complex systems due to the methodology’s ability to track system complexity from stakeholders and requirements to design and test; this methodology has been used to develop baby robots [31], [32]. Typically, requirements are measurable statements of performance, usually anchored in repeatable/testable actions. System design for RL robotics carries a unique challenge—the actions and capabilities are unknown in advance. Enumerating all possible actions is not practical, leading us instead to focus on system robustness, actuation, and sensing. Thus, the central requirements for this project are the following:

- 1) The robot shall be very robust in the designated environments.
- 2) The robot shall be protected from harming itself.
- 3) The robot shall primarily use cameras for sensing.
- 4) The robot shall have a high number of degrees of freedom.

For acceptance tests, these requirements are very vague and impossible to clearly demonstrate. Instead, these requirements form guiding principles for a systems model and iterative design based on performance during tests. We selected SysML v2 [15] for MBSE, enabling equation-based relationships to be fully defined within the model. For example, we initially had four cameras and three actuators per limb. Increasing cameras resulted in additional processing hardware, increased heat, increased size, and increased weight. Likewise, increasing degrees of freedom increases the number of actuators, power requirements, heat, controllers, and size. Each relationship is defined in the model, resulting in predictions prior to fabrication. We based

simulation models using Gazebo [36] on Fusion 360⁹ design models, defined in the MBSE model, enabling simulation performance to be compared to model predictions. We used hardware tests to improve the MBSE model, further refining each iteration. The effect of systems design for AI was most clearly demonstrated moving from human-controlled tests to AI-controlled tests, as human attempts to test robustness were notably different than RL-controlled actions.

IV. MECHANICAL DESIGN

a) Materials selection: The robot is 3D printed with PLA—a widely used material, enabling fast and relatively low-cost prototyping. Printing is performed by Creality Ender 5 3D printer—a common, relatively low-cost 3D printer. The hinges of the tentacle are cast using flexible urethane rubber (smooth on-PMC™-780 DRY) to prevent damage due to impact and compression commonly found in hinges constructed from traditional materials. The two-part urethane material is cast using a reusable 3D printed mold, for fast mold iteration and cost-effective manufacturing. A single casting run yields double the number of hinges needed, leaving spare parts or an extension ability. A braided fishing line is used as a tendon to actuate the main tentacle. This fishing line is rated for 100 lb, exceeding the expected range of force the robot is going to encounter. The brackets and servo horns are Commercial Off-The-Shelf (COTS) to simplify the design and assembly process.

b) Design: The tentacles are designed to behave in a natural octopus-like manner while housing and protecting the cameras in each segment, with encased wiring. We selected flexible materials for parts that are prone to impact damage. In this iteration, the critical parts are the hinges; when hinges are damaged or bent, the robot is not able to

respond consistently, causing a discrepancy in operation. We placed flexible hinges and tendons to enable flexing in two directions, and we designed segments and hinges such that the number of segments can be modified between robots without major redesigns. Figure 2 shows an exploded view of the robot components. Segments can be divided into three major types: the tip connects to an enclosure housing two cameras; the connecting segment features one camera and a shape to ease the tendon route to the tip; the extension segment housing a camera is used to extend the robot length or add more cameras. Those segments connect to the base, where two cameras are housed alongside the servo motor responsible for the tentacle movement via tendon actuation. The foregoing tendons are actuated using a custom pulley for bidirectional control. The pulley clamps around each side of the tendon to avoid slippage.

The base connects to a servo, acting like a wrist to allow for rotation. The tower mounts two motors that act like the robot’s shoulder, driving the vertical and horizontal motions. The combined motion of the actuators allows the robot to point the cameras and curl the tentacle in a semi-sphere, perform a grab motion in a 180° rotation from the main axis, move left/right in a 180° arc around the tower’s vertical axis, and move in an up/down arc of approximately 180°.

We designed control wire routing to avoid binding during motion. Wire routing in the tower reduces limitations that will not be present on the future body. The base of the tower houses the electronics and power connections.

c) Cameras and sensors: We chose to embed cameras in the segments and base, encasing them in a shell to secure them and protect them from damage. Shells are shown in green in Figure 2. The flexible hinge between the segments is an impact absorber to protect cameras from damage. Camera wires slide through segments to reach the electronics

⁹See <https://www.autodesk.com/products/fusion-360>

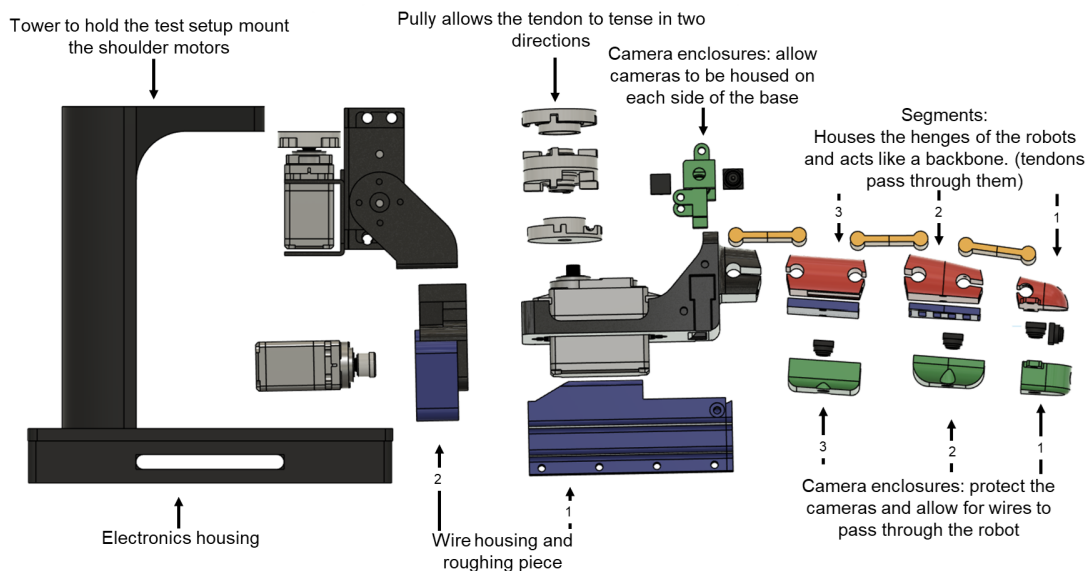

Fig. 2: Exploded view of the Robot with colour-coding based on function—segments (red), brackets (black), camera enclosures (green), cable management (blue), and attachments(gray).

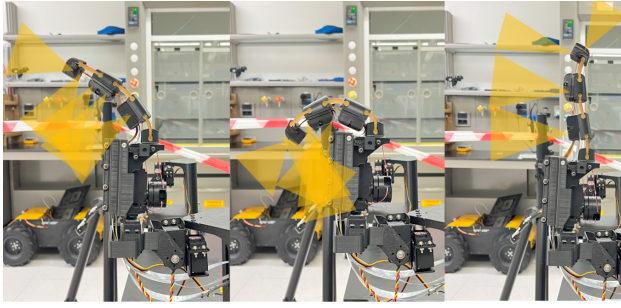

Fig. 3: The effect on the field of view for the four front-facing cameras when the limb is extended and retracted.

housing. We designed the wire route to protect the wires and allow for some slack to avoid limiting movement. We placed cameras such that three cameras are aimed toward the region where the robot is going to grab objects and primarily interact with its environment. We aimed one camera forward from the tip, and we aimed the last two cameras to the right and left of the base. Figure 3 visualizes Field of Views (FOVs) in a different flexing of the tentacle. The wires are gathered at the housing and then routed to the rack under the rotation servo to be guided to the electronics box.

d) Prototyping Process: The robotic limb went through several iterations to improve its perception, motion, rigidity, flexibility, and assembly through improvements in materials, degrees of freedom, and number of cameras. We 3D printed all custom parts to evaluate motion and refine designs. We commanded initial motion via servo commands to assess interactions and limitations, evaluate designs, and focus improvements. The robot is stable under its weight and able to manipulate light objects, such as an inflated glove. We went through multiple iterations of ancillary parts, such as the molds used for the hinges, to enable the mold to release easily and the hinges to maintain desired shapes.

e) Challenges: Wire routing is one of the main challenges faced during the design phase. Size constraints force electronics near the base, resulting in long extension cables between cameras and microcontrollers, which impinges robot motion or damages wires. Therefore, we designed a two-layer passive tensioning attachment, wire housing, and a routing attachment to enable the wires to reach the base without hindering motion while protecting the cables. A second obstacle is the tendon connection to the servo; the tendon must avoid slipping while enabling actuation in both directions. We created a pulley where the tendon is routed through teeth-like clamps to secure the tendon while minimizing risk of derailment.

f) Limitations: The current design attaches the robot to the testing tower, limiting rotation about the vertical axis. We focused current tests on sensing, not manipulating objects. Assessing strength limitations and accurate range of motion are the next testing steps. Routing for the camera wire is an obvious weak point that we are currently improving.

V. ELECTRONICS DESIGN

Electronics design for this robot is challenging. Per the requirements in Section III, a significant number of vision-based sensors is required. Per the AI team, these sensors must transmit all data back to the brain for processing instead of edge processing. These requirements result in a high number of cameras, a high number of microprocessors for processing images, and high-bandwidth networking for transporting the images. Further, the goal to keep costs low with the ability to iterate quickly points towards COTS solutions. We selected ESP32-Cam(s)¹¹—cheap microprocessors that combine with OV2640¹² vision sensors and provide WiFi, Bluetooth, and micro-SD storage capabilities—as we can obtain them in high quantities for very low costs. The wireless networking of these boards consumes significant resources, generates significant heat, and results in complicated IP management. For dual-core ESP32s, resource use is not an issue. Most low-cost ESP32-Cams are single-core, causing resource starvation. Further, the heat is a problem within the protective skin layer. To avoid these issues, we chose to use physical wires. The ESP32 has a PHY—enabling a MAC address—but using this capability would require additional hardware to convert to an Ethernet port, increasing size and complexity. Instead, we integrated SatCat5 [37]—an open-source mixed-mode FPGA-based networking solution that was originally developed for use on cube satellites. SatCat5 enables the networking to connect directly through serial, which is exposed on the ESP32-Cam(s). Each ESP32-Cam is given a fake MAC address (generated randomly and stored), which is then learnt by the brain for sensor feedback and actuator control. Frame rates of up to 13FPS (Frames per Second) are available for 100x100 images, with the limitation being the ESP32-Cam processing, not the networking. Figure 4 shows the wiring diagram for a single limb, and Figure 5 shows

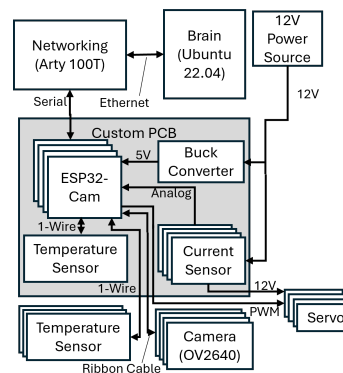

Fig. 4: Wiring Diagram including the Arty A7 development board¹⁰ for networking.

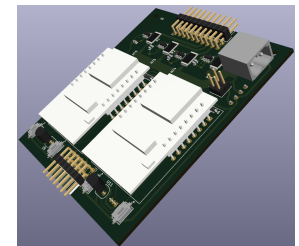

Fig. 5: The custom PCB for combining ESP32-Cam(s), sensors, and power/networking wiring management.

¹⁰See <https://digilent.com/shop/arti-a7-100t-artix-7-fpga-development-board/>

¹¹See <https://docs.ai-thinker.com/en/esp32-cam>

¹²See https://www.uctronics.com/download/cam_module/OV2640DS.pdf

the custom PCB used to combine the ESP32-Cams, current sensors, and thermal sensors.

VI. MACHINE LEARNING EXPERIMENT

a) Methodology: As a proof of concept for the robotic limb, we train the robotic limb to perform a simple target-finding task using two contemporary algorithms. Specifically, at each step, the robot must move the servo motors so that a specific Apriltag [38] appears in any of the four cameras spread out along its upper three joints (see Figure 6). The first algorithm we use is a modified version of CleanRL’s [39] implementation of the Proximal Policy Optimization (PPO) algorithm [40]. Here, the state is the four servo positions, the actions are four-dimensional vectors indicating the adjustment that should be made to the current position of the servos (clipped to $[-36^\circ, 36^\circ]$), and the reward is 1 when the target is spotted and 0 otherwise. At each iteration of this version, we unroll the current policy for 15 episodes (each episode terminating when the target is spotted) before updating the network. The episodes are truncated to have a maximum of 5 steps to deal with issues arising from the sparse reward signal. The algorithm is run on an external computer, and the artificial neural network is trained using the PyTorch library [41] running with CUDA¹³ on an Nvidia RTX 3070. The second algorithm we use is the discrete actor-critic (AC) algorithm with Gaussian parameterization [42], [43], [44]. For this, the state and reward function are as before, but the action space is 8 dimensional, with each action corresponding to a shift in one servo motor of 22.5° in either a positive or negative direction. With AC, the episodes were never truncated. We ran PPO for 10 repetitions and AC for 30. All the experiments were done online, in real time, and with minimal supervision. For transparency, we release the source code for these experiments at <https://github.com/dylanashley/robot-limb-testai>



Fig. 6: In our experiment, we use the four front-facing cameras and train the robot to move from the central position of the servos to a position where the target is in sight of one or more of the cameras.

b) Results: The experimental results are shown in Figure 7. The maximum and minimum number of steps that could appear here for PPO is 5 and 1, as that is, respectively, the truncated length of the episode and the number of steps required by an optimal policy. The maximum number of steps is unbounded for AC, and very long episodes were observed, which skewed the averages shown in the learning curve. Later phases of training were dominated by short episodes for both PPO and AC, with both significantly outperforming Brownian noise baselines in their final iterations ($p < 0.01$ using Student’s t-tests with Holm-Bonferroni corrections).

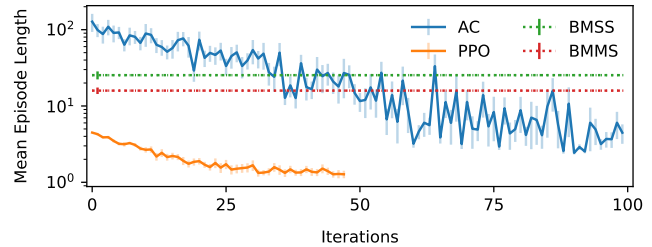

Fig. 7: Performance of PPO over iterations and AC over episodes. Both show dramatic performance improvements in a relatively short time. By the end, both algorithms significantly outperform ($p < 0.01$) their respective baselines: Brownian noise with multiple (all) servos (BMMS) and a single servo (BMSS).

c) Discussion: These experiments show that the algorithms are able to converge to optimal behaviour under the assumption violations introduced by the robotic platform. The lack of any divergent runs reinforces this result. Thus, the overall system is suitable to the rigours of training state-of-the-art machine learning algorithms from scratch and thus satisfies our primary objective outlined in Section I.

VII. CONCLUSIONS AND FUTURE WORK

This paper details our design and build of a robust soft robotic limb for machine learning experiments. The limb in question has 6 cameras and 4 servo motors. We show that this limb is robust to AI experiments by conducting a simple target-finding task and demonstrating convergence.

While already useful, this limb is only a first step towards a more sophisticated starfish-like robot equipped with many limbs that each have several servo motors and many cameras. Immediate future work will focus on the mechanical design needs of the final robot and on conducting experiments to improve the material selection to maintain the required fluidity without affecting the rigidity required for dexterity and object manipulation. In particular, the body must be designed to allow the connection of multiple replaceable tentacles with more degrees of freedom, facilitating locomotion with low-latency transmission to an off-robot base station.

REFERENCES

- [1] OpenAI, *Introducing ChatGPT*. OpenAI, 2022. [Online]. Available: <https://openai.com/blog/chatgpt>

¹³See <https://developer.nvidia.com/cuda-zone>

- [2] A. Ramesh, M. Pavlov, G. Goh, S. Gray, C. Voss, A. Radford, M. Chen, and I. Sutskever, "Zero-shot text-to-image generation," *Proceedings of the 38th International Conference on Machine Learning*, pp. 8821–8831, 2021.
- [3] A. Ramesh, P. Dhariwal, A. Nichol, C. Chu, and M. Chen, "Hierarchical text-conditional image generation with CLIP latents," *CoRR*, vol. abs/2204.06125, 2022.
- [4] J. Betker, G. Goh, L. Jing, T. Brooks, J. Wang, L. Li, L. Ouyang, J. Zhuang, J. Lee *et al.*, "Improving image generation with better captions," *Computer Science*. <https://cdn.openai.com/papers/dall-e-3.pdf>, vol. 2, no. 3, p. 8, 2023.
- [5] J. Jumper, R. Evans, A. Pritzel, T. Green, M. Figurnov, O. Ronneberger, K. Tunyasuvunakool, R. Bates, A. Židek *et al.*, "Highly accurate protein structure prediction with AlphaFold," *Nature*, vol. 596, no. 7873, pp. 583–589, 2021.
- [6] R. Roy, J. Raiman, N. Kant, I. Elkin, R. Kirby, M. Y. Siu, S. F. Oberman, S. Godil, and B. Catanzaro, "Prefixrl: Optimization of parallel prefix circuits using deep reinforcement learning," in *ACM/IEEE Design Automation Conference*. IEEE, 2021, pp. 853–858.
- [7] M. G. Bellemare, S. Candido, P. S. Castro, J. Gong, M. C. Machado, S. Moitra, S. S. Ponda, and Z. Wang, "Autonomous navigation of stratospheric balloons using reinforcement learning," *Nature*, vol. 588, no. 7836, pp. 77–82, 2020.
- [8] J. Degrave, F. Felici, J. Buchli, M. Neunert, B. Tracey, F. Carpanese, T. Ewalds, R. Hafner, A. Abdolmaleki *et al.*, "Magnetic control of tokamak plasmas through deep reinforcement learning," *Nature*, vol. 602, no. 7897, pp. 414–419, 2022.
- [9] O. Vinyals, I. Babuschkin, W. M. Czarnecki, M. Mathieu, A. Dudzik, J. Chung, D. H. Choi, R. Powell, T. Ewalds *et al.*, "Grandmaster level in starcraft II using multi-agent reinforcement learning," *Nature*, vol. 575, no. 7782, pp. 350–354, 2019.
- [10] D. Wierstra, A. Förster, J. Peters, and J. Schmidhuber, "Solving deep memory pomdps with recurrent policy gradients," *Proceedings of the 17th International Conference Artificial Neural Networks*, pp. 697–706, 2007.
- [11] —, "Recurrent policy gradients," *Log. J. IGPL*, vol. 18, no. 5, pp. 620–634, 2010.
- [12] M. Andrychowicz, B. Baker, M. Chociej, R. Józefowicz, B. McGrew, J. Pachocki, A. Petron, M. Plappert, G. Powell *et al.*, "Learning dexterous in-hand manipulation," *International Journal of Robotics Research*, vol. 39, no. 1, 2020.
- [13] D. Korenkevych, A. R. Mahmood, G. Vasana, and J. Bergstra, "Autoregressive policies for continuous control deep reinforcement learning," *Proceedings of the 28th International Joint Conference on Artificial Intelligence*, pp. 2754–2762, 2019.
- [14] J. Peters and S. Schaal, "Reinforcement learning by reward-weighted regression for operational space control," *Proceedings of the 24th International Conference on Machine Learning*, vol. 227, pp. 745–750, 2007.
- [15] SysML v2 Submission Team, "Sysml-v2-release," 2022. [Online]. Available: <https://github.com/Systems-Modeling/SysML-v2-Release>
- [16] A. Y. Ng, A. Coates, M. Diel, V. Ganapathi, J. Schulte, B. Tse, E. Berger, and E. Liang, "Autonomous inverted helicopter flight via reinforcement learning," *Proceedings of the 9th International Symposium on Experimental Robotics*, pp. 363–372, 2006.
- [17] D. M. Wolpert, Z. Ghahramani, and J. R. Flanagan, "Perspectives and problems in motor learning," *Trends in Cognitive Sciences*, vol. 5, no. 11, pp. 487–494, 2001.
- [18] J. Peters and S. Schaal, "Natural actor-critic," *Neurocomputing*, vol. 71, no. 7-9, pp. 1180–1190, 2008.
- [19] —, "Applying the episodic natural actor-critic architecture to motor primitive learning," *Proceedings of the 15th European Symposium on Artificial Neural Networks*, pp. 295–300, 2007.
- [20] T. Degris, P. M. Pilarski, and R. S. Sutton, "Model-free reinforcement learning with continuous action in practice," *Proceedings of the 2012 American Control Conference*, pp. 2177–2182, 2012.
- [21] M. L. Littman, R. S. Sutton, and S. Singh, "Predictive representations of state," *Advances in Neural Information Processing Systems*, vol. 14, pp. 1555–1561, 2001.
- [22] J. Modayil, A. White, and R. S. Sutton, "Multi-timescale nexting in a reinforcement learning robot," *Adaptive Behavior*, vol. 22, no. 2, pp. 146–160, 2014.
- [23] M. B. Ring, "Representing knowledge as predictions (and state as knowledge)," *CoRR*, vol. abs/2112.06336, 2021.
- [24] P. M. Pilarski, M. R. Dawson, T. Degris, J. P. Carey, K. M. Chan, J. S. Hebert, and R. S. Sutton, "Adaptive artificial limbs: A real-time approach to prediction and anticipation," *IEEE Robotics & Automation Magazine*, vol. 20, no. 1, pp. 53–64, 2013.
- [25] P. M. Pilarski, T. B. Dick, and R. S. Sutton, "Real-time prediction learning for the simultaneous actuation of multiple prosthetic joints," *Proceedings of the 13th IEEE International Conference on Rehabilitation Robotics*, pp. 1–8, 2013.
- [26] P. M. Pilarski, M. R. Dawson, T. Degris, J. P. Carey, and R. S. Sutton, "Dynamic switching and real-time machine learning for improved human control of assistive biomedical robots," *Proceedings of the 4th IEEE International Conference on Biomedical Robotics and Biomechatronics*, pp. 296–302, 2012.
- [27] A. L. Edwards, M. R. Dawson, J. S. Hebert, C. Sherstan, R. S. Sutton, K. M. Chan, and P. M. Pilarski, "Application of real-time machine learning to myoelectric prosthesis control: A case series in adaptive switching," *Prosthetics and Orthotics International*, vol. 40, no. 5, pp. 573–581, 2016.
- [28] A. L. Edwards, J. S. Hebert, and P. M. Pilarski, "Machine learning and unlearning to autonomously switch between the functions of a myoelectric arm," *Proceedings of the 6th IEEE International Conference on Biomedical Robotics and Biomechatronics*, pp. 514–521, 2016.
- [29] G. Vasana, "Teaching a Powered Prosthetic Arm with an Intact Arm Using Reinforcement Learning," 2017, master's thesis, University of Alberta.
- [30] J. Saleh, G. Mark, and N. Jordan, "Flexibility: a multi-disciplinary literature review and a research agenda for designing flexible engineering systems," *Journal of engineering design*, vol. 20, no. 3, pp. 307–323, 2009.
- [31] H. Zhu, S. Wilson, and E. Feron, "The design, education and evolution of a robotic baby," *IEEE Transactions on Robotics*, vol. 39, no. 3, pp. 2488–2507, 2023.
- [32] H. Zhu and E. Feron, "A systems engineering approach to the design and education of a robotic baby," *INCOSE International Symposium*, vol. 31, no. 1, pp. 327–342, 2021.
- [33] A. Turing, "Computing machinery and intelligence," *Mind*, vol. 59, no. 236, pp. 433–460, 1950.
- [34] R. V. Martinez, A. C. Glavan, C. Keplinger, A. I. Oyetibo, and G. M. Whitesides, "Soft actuators and robots that are resistant to mechanical damage," *Advanced Functional Materials*, vol. 24, no. 20, pp. 3003–3010, 2014.
- [35] R. R. Ma, L. U. Odhner, and A. M. Dollár, "A modular open-source 3d printed underactuated hand," *Proceedings of the IEEE International Conference on Robotics and Automation*, pp. 2722–2727, 2013.
- [36] N. Koenig and A. Howard, "Design and use paradigms for gazebo, an open-source multi-robot simulator," *Proceedings of the IEEE/RSJ International Conference on Intelligent Robots and Systems*, vol. 3, pp. 2149–2154, 2004.
- [37] A. Utter, M. Zakrzewski, A. Keene, S. Dietrich, S. Lin, E. McDonald, N. Whitehair, and J. Zheng, "Satcat5: A low-power, mixed-media ethernet network for smallsats," *Proceedings of the 34th Annual Small Satellite Conference*, 2020.
- [38] E. Olson, "Apriltag: A robust and flexible visual fiducial system," *Proceedings of the IEEE International Conference on Robotics and Automation*, pp. 3400–3407, 2011.
- [39] S. Huang, R. F. J. Dossa, C. Ye, J. Braga, D. Chakraborty, K. Mehta, and J. G. M. Araújo, "Cleanrl: High-quality single-file implementations of deep reinforcement learning algorithms," *Journal of Machine Learning Research*, vol. 23, pp. 274:1–274:18, 2022.
- [40] J. Schulman, F. Wolski, P. Dhariwal, A. Radford, and O. Klimov, "Proximal policy optimization algorithms," *CoRR*, vol. abs/1707.06347, 2017.
- [41] A. Paszke, S. Gross, F. Massa, A. Lerer, J. Bradbury, G. Chanan, T. Killeen, Z. Lin, N. Gimelshein *et al.*, "Pytorch: An imperative style, high-performance deep learning library," *Advances in Neural Information Processing Systems*, vol. 32, pp. 8024–8035, 2019.
- [42] I. H. Witten, "An adaptive optimal controller for discrete-time markov environments," *Information and Control*, vol. 34, no. 4, pp. 286–295, 1977.
- [43] A. G. Barto, R. S. Sutton, and C. W. Anderson, "Neuronlike adaptive elements that can solve difficult learning control problems," *IEEE Transactions on Systems, Man, and Cybernetics*, vol. 13, no. 5, pp. 834–846, 1983.
- [44] R. S. Sutton and A. G. Barto, *Reinforcement learning: An introduction*, 2nd ed. MIT Press, 2018.