

# Attention based End to end network for Offline Writer Identification on Word level data

Vineet Kumar and Suresh Sundaram

**Abstract**—Writer identification due to its widespread application in various fields has gained popularity over the years. In scenarios where optimum handwriting samples are available, whether they be in the form of a single line, a sentence, or an entire page, writer identification algorithms have demonstrated noteworthy levels of accuracy. However, in scenarios where only a limited number of handwritten samples are available, particularly in the form of word images, there is a significant scope for improvement.

In this paper, we propose a writer identification system based on an attention-driven Convolutional Neural Network (CNN). The system is trained utilizing image segments, known as fragments, extracted from word images, employing a pyramid-based strategy. This methodology enables the system to capture a comprehensive representation of the data, encompassing both fine-grained details and coarse features across various levels of abstraction. These extracted fragments serve as the training data for the convolutional network, enabling it to learn a more robust representation compared to traditional convolution-based networks trained on word images. Additionally, the paper explores the integration of an attention mechanism to enhance the representational power of the learned features. The efficacy of the proposed algorithm is evaluated on three benchmark databases, demonstrating its proficiency in writer identification tasks, particularly in scenarios with limited access to handwriting data.

**Index Terms**—Writer identification, Attention network, Convolution Neural Network.

## I. INTRODUCTION

Handwriting is a form of behavioural biometric [1] having a distinguishing character comparable to iris and fingerprint that enables the identification of a person. It has been effectively employed in many fields such as forensic analysis [2], historical document analysis [3], [4], security [5] to name a few. Writer identification involves presenting a list of likely writers in order to identify the authorship of an unidentified document from a collection of reference documents that have been placed in the database. Based on the methodology employed to acquire the writer's data it can be broadly grouped into offline and online [6]. In the online method, the temporal writer features such as coordinates, pressure, and angle is captured by specific devices such as a tablet. In the offline method, the document containing handwritten text is generally captured in the form of an image and analysed subsequently. In addition to this based on the content of the handwritten text, it is further categorized into text-dependent and text-independent approaches. In the text-dependent approach, the content of

the handwritten text is fixed, on the other hand in the text-independent approach the content of the handwritten text can vary.

Before modern technology emerged, handwriting analysis relied heavily on manual examination by skilled experts. These experts were required to have subject expertise to analyze and identify the distinguishing patterns within the handwriting samples. However, the absence of consistency in selecting a discerning pattern frequently leads to varied interpretations, resulting in inconclusive outcomes. An automated writer identification system attempts to solve this issue by extracting discriminating patterns from the input based on a set of predefined conditions, thus making the overall process fast and efficient. Based on the literature the features extracted from handwritten text can be broadly categorized into two groups: handcrafted features and deep learning-based features. The former employs a traditional method of feature extraction, which entails identifying characteristics, properties, attributes, and other relevant factors from handwritten images based on domain expertise. On the other hand the latter employs neural network-based techniques, such as CNN, RNN, and LSTM, to automatically learn data-dependent features from the training images. Based on the review of literature, methods relying on handcrafted features can be further categorized into two groups: Texture-based and shape-based features.

Texture-based methods treat a handwriting image as a series of textures [7]. This method uses either frequency transform-based techniques in the form of Gabor filter [7], XGabor filters [8], and Wavelet [9], [10] or spatial techniques employing features such as LBP LQP [11], [12], gray level co-occurrence matrix [13] and oriented Basic Image Features (oBIF) [14], [15] to characterize a writers information.

Shape features, in contrast to spatial distribution features, characterize handwriting qualities by analyzing the local closed sections of characters or letters, represented as allo-graphs [16], [17], graphemes [18]–[20], and fragments [21]–[24], utilizing codebook-based methods [16], [21], [25]. These codebooks leverage the morphological redundancy inherent in writer structures by grouping frequently occurring patterns into a predetermined number of clusters. Subsequently, these clusters are employed to describe a handwriting sample by assessing the distribution pattern of the occurrences of these codebook entries.

Unlike traditional methods, deep neural network-based techniques directly learn feature mappings from training data. This approach enables the utilization of more data-adaptive information within the learned features, leading to improved recognition performance when compared to hand-designed feature descriptors. The concept of convolution neural network

The authors are associated with Department of Electronics and Electrical Engineering, Indian Institute of Technology Guwahati, Guwahati 781039, India (email: vineet18@iitg.ac.in, sureshsundaram@iitg.ac.in).

(CNN) in the field of Handwriting recognition was pioneered by Fiel *et.al* [26]. In their work, they trained a CNN having five convolutions and three fully connected layers. Features extracted from the penultimate layer were used for characterising a writer based on which the identity of the writer is determined by comparing the  $\chi^2$  distance. Subsequently, several deep neural network-based approaches were proposed [6], [27]–[32], employing the CNN module exclusively for feature extraction, followed by a separate standalone classification module for classifying the writer samples. Yang *et al.* [33] introduced an end-to-end convolutional network integrating feature extraction with classification. In their work, the authors introduced the concept of path signature features and Drop-stroke to improve the generalization of writer samples. Xing *et.al* in [34] proposed a deep multistream end-to end- trained deep convolution network wherein the handwritten patches from two adjacent segments are employed to learn effective feature representation for recognizing the writers.

The aforementioned methods demonstrate promising performance on page-level or text-line-level data, but they fall short in providing satisfactory results when presented with a word image as input. This discrepancy in results can be attributed to the nature of CNN networks, which prioritize learning the most distinguishing patterns in input images to accomplish classification tasks by minimizing training loss. These patterns are readily noticeable in page-level or text-line-level inputs. However, due to the limited amount of handwritten data available within word images, deep learning techniques utilizing CNN/RNN struggle to adequately encode the requisite local and global information necessary to capture unique handwriting styles. A notable contribution in the field of writer identification involving limited data is presented in [35], where the authors propose a multitasking framework employing two parallel streams of CNN networks applied to word images, merging features from an auxiliary task with the main task to enhance writer-related information by incorporating attributes from both tasks. In a subsequent work [36], the same authors introduce Fragnet, a deep neural network model that adopts a fragment-based approach, amalgamating information from input image fragments with the feature map output of a convolutional block to identify the writer and extract crucial writer-specific features through a feature pyramid. In a subsequent extension of their work [37], the authors employ a recurrent neural network (RNN) to exploit the spatial relationship between the fragments in the sequence.

In recent years, attention-based networks have found widespread application in the realm of deep neural networks. The incorporation of attention mechanisms enables networks to concentrate on relevant input regions, thereby capturing relationships among different segments of the input image. Essentially, this capability empowers networks to emphasize important features while reducing the influence of irrelevant ones. In the context of the handwriting domain, Shaikh *et.al* [38] incorporated a cross-attention with soft-attention mechanisms to capture highly correlated and salient points within the feature space of handwriting input pairs for writer verification. Chen *et.al* in [39] introduce a Hierarchical Attention Pooling (HAP) layer, comprising writing style attention, writing

temporal attention, and letter attention modules, leading to an efficient and compact feature representation. In [40] the authors employed an attention-based filter to select key points in historical documents. Lastly, in [41] the authors employed Residual Swin Transformer Classifier (RSTC), that effectively combines local and global handwriting styles, yielding robust feature representations for word images.

## II. RESEARCH FRAMEWORK

In this paper, we introduce an end-to-end writer identification system based on Convolutional Neural Networks (CNNs) designed to determine the authorship of handwritten documents using word images. Traditional neural network methods typically involve inputting the image directly into the network for feature extraction and subsequent classification. While effective for page-level or sentence-level data, these methods often falter in scenarios where access to handwritten samples is restricted, such as with word images containing fewer than 5 letters. Several factors contribute to this decline in performance:

- The majority of existing deep learning algorithms are trained to prioritize the most discriminative parts of an image, neglecting other equally vital local features crucial for accurate writer identification.
- Limited handwritten data with diverse content poses challenges in effectively encoding dependencies between neighboring strokes of the word image.

These factors collectively contribute to the reduced performance of the system in scenarios with constrained access to handwritten samples, particularly those involving word images.

A more effective strategy for addressing this challenge involves viewing the input image not as a single entity but as a collection of fragments that encapsulate the structural attributes of the image. This approach provides a notable advantage by shifting the focus away from emphasizing the most discriminative feature of the input training image. Instead, it compels the network to acquire a more resilient representation from a collection of fragments. Operating on this principle, rather than employing the entire word image for feature extraction and classification, we employ features extracted from a collection of local patches (referred to as fragments) to identify the writer of the word image.

For extracting fragments from an input image SIFT algorithm [42] is employed, which uses a multi-scale analysis to locate regions containing distinct features ranging from characters to allographs and graphemes from an input word image. These fragments are then fed into a CNN network featuring two parallel streams of convolution modules. One of which is trained on writer-dependent samples, while the other is trained on handwritten samples that is language as well as writer-independent. In this setup, the former stream encodes the writer-specific local structure from the word fragment, while the latter captures writer-independent general features. This configuration is expected to outperform the baseline, which relies solely on the writer-dependent model, as a writer module trained solely on writer data may lead to overfitting, resulting

in the loss of generality of the writer features. By integrating the writer features learned by the writer-independent auxiliary network, we tend to introduce regularization into the overall network, aiming to mitigate the impact of overfitting [43].

In summary, the key contributions of this paper include:

- Investigating writer characterization through fragments extracted from word images.
- Proposing a multi-stream end-to-end Convolution network trained on writer-dependent and independent datasets showcasing its effectiveness in capturing writer features.
- Examining the impact of integrating an attention mechanism on the overall performance of the system.

The remainder of the paper is structured as follows. We begin by explaining the process of generating word fragments using SIFT keypoint algorithm in section III. This is succeeded by a detailed explanation of the CNN block employed for training an end-to-end writer identification system in section IV. Section V conducts a detailed analysis of the attention block, while Section VI delves into the training and classification strategy associated with the proposed CNN model. The databases used for evaluating our proposed method along with the experimental results to evaluate the efficacy of our proposed network is described in section VII. Finally, we summarize our paper in section VIII.

### III. PATCH EXTRACTION USING SIFT ALGORITHM

A writer identification algorithm depends on characterizing the writer information obtained from input images, which can be collected from pages, text lines, or individual words. The underlying information is extracted from these input by analyzing attributes such as image texture, graphemes, allographs, or characters, representing different levels of observation. These extracted features impact the overall performance of the system. As such, feature selection forms an integral part of any writer identification system. Majority of the techniques (traditional as well as deep learning based) [6], [11], [12], [20], [44] use dense sampling, by employing a fixed-sized window in an overlapping/ non-overlapping framework to segment regions around an image. However, as the discriminative ability of different characters in handwritten text varies, selecting areas around an interest point or keypoint may prove more effective in describing a writer compared to random sampling. Consequently, interest point-based methods have gained widespread application in the field of writer identification. These approaches typically employ a fixed-sized window to extract the region of interest around the image, incorporating features such as junctions [22] and corners [32], [45] to characterize a writer.

One notable limitation of employing a fixed-size feature detection window is its challenge in accurately capturing components of varying sizes, especially when image features demonstrate frequent fluctuations in shapes and dimensions. Therefore, rather than adopting a fixed-size window approach that identifies interest points at a predefined level of abstraction, we turn to the Scale-Invariant Feature Detector, commonly known as SIFT [42]. This detector utilizes a

pyramidal-based method to detect and extract key points at multiple resolutions, thereby facilitating localization in diverse scenarios.

This algorithm can be broken into the following steps. In the initial phase, the original image undergoes successive down-sampling, forming a Gaussian pyramid with each level referred to as an octave. This pyramid is further divided into several sub-levels by convolving the initial image with Difference of Gaussian (DoG) filters of varying variance. In the subsequent stage, the DoG images produced in the preceding step are analyzed to derive a collection of stable key points. Following this, orientation and scale details is extracted from the stable keypoint, determining the size of the associated window. Some of the fragments generated using SIFT algorithm is shown in 1.

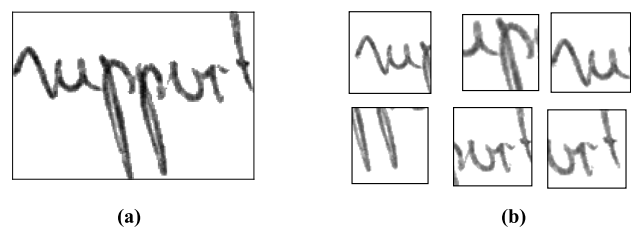

Fig. 1: Fragment generation from an input word using SIFT. (a) An Input word image from CVL dataset, (b) Extracted fragments.

### IV. CNN MODEL

Following patch extraction, there is a requirement to map it to a feature for identification or classification purposes. Prior studies predominantly relied on texture and codebook based methods to represent a writer's feature [11], [20], [22]. However, recent years have witnessed a significant shift in the approach towards writer identification, with hand-engineered traditional methods being replaced by machine learning and deep learning-based algorithms [6], [28], [46]. These algorithms adopt a data-driven approach to directly learn features from the input data. Convolutional Neural Networks (CNNs) falls in this category, it characterized by a series of convolution and sub-sampling layers within the network. Each convolution layer in a convolutional block comprises a set of filters, employed to extract features from the preceding layers through the convolution operation. The weights of these filters in a convolution block is updated during the training process using backpropagation. Typically, this network terminates with a series of fully connected layers, serving as a mapping function between the outputs of the convolutional layers. These densely connected layers play a crucial role in exploring non-linearities associated with high-level features extracted from the convolution block, thus facilitating the classification of input data into predefined classes.

The overall architecture of our proposed CNN model is shown in Figure 2. This model consists of two parallel CNN blocks trained on writer-dependent and writer-independent data to capture the writer-specific and writer-independent

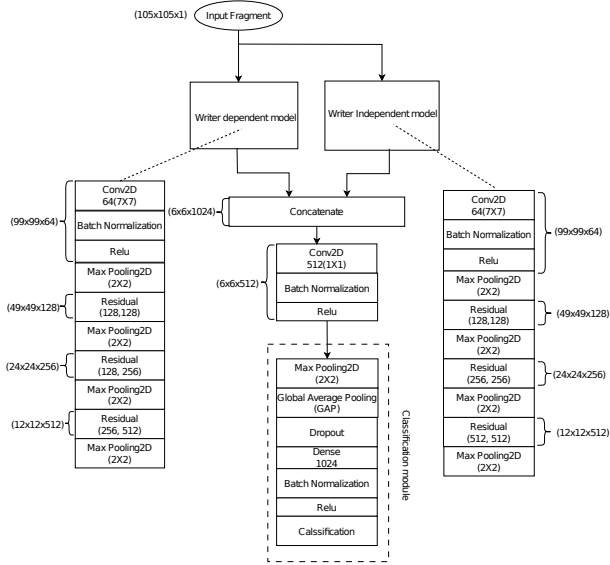

Fig. 2: The architecture of CNN model used for training the writer dataset. Each convolution block and its variant (represented in this figure as Conv2D/Seperable Conv2D) is followed by entries signifying the number of filters and their kernel size respectively.

features associated with the input samples. The subsequent subsections delve into the specifics of each block's composition and function.

#### A. Writer dependent module

Every writer possesses a unique handwriting style, characterized by distinct segments or patterns that may exhibit certain similarities among them. The process of identifying these shared traits within a handwritten sample serves a crucial role in authenticating the authorship of the document. The objective of the writer-dependent Convolutional Neural Network (CNN) module is to extract pertinent details from the input fragments at both the character and sub-character levels.

The architecture of the writer-dependent module comprises a series of convolutional layers, each followed by Batch-Normalization and a Rectified Linear Unit (ReLU) layer sequentially. These convolution layers are equipped with a range of filters spanning from 64 to 512, featuring a kernel size of  $(n \times n)$ , where  $n$  takes values from the set  $(1, 3, 7)$ . Notably, certain convolution blocks incorporate skip connections, thereby transforming them into residual blocks, as depicted in Figure 3. The utilization of skip connections enhances the network's ability to capture intricate features while mitigating the vanishing gradient problem.

A significant portion of the convolutional operations within the writer-dependent block is executed via separable convolution. Unlike standard convolution, which applies a kernel across the entire input volume simultaneously, separable convolution operates in two stages. Initially, a convolution operation is conducted along each channel of the input independently. Subsequently, a  $(1 \times 1)$  point-wise convolution is performed across the channels [47]. This strategy effectively

reduces the total number of trainable parameters compared to traditional convolution, thereby enhancing computational efficiency without much compromise in performance.

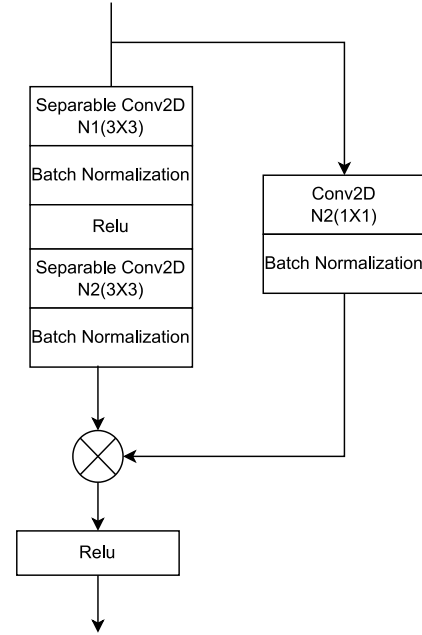

Fig. 3: The architecture of the residual block used in the convolution network. Each residual block in the network is followed by entries N1 and N2 specifying the number of filters in the residual block.

#### B. Writer Independent module

The main objective of this module is to extract general features from the input image that is writer as well as data independent. Most of the convolution networks are trained using a classification framework which emphasizes on learning patterns from the training data. One of the limitations of this framework is that it requires a large amount of training data an absence of which may hinder the deep learning models' ability to accurately model various classes, leading to poor performance. Consequently, networks structured within a classification framework are predominantly designed to identify local features and may not effectively capture broader, generalized features.

To achieve the objective of generalization, we employ a dissimilarity-based approach. In contrast to traditional classifiers that prioritize pattern identification, this approach focuses on recognizing distinctions or dissimilarities between data points. This dissimilarity measure is typically framed as a distance metric within an acquired embedding space, wherein inputs sharing commonalities or belonging to the same class are brought closer together, while those from disparate classes are pushed farther apart. The objective of dissimilarity learning is implemented using a class of neural networks called the Siamese network. Such a network uses the concept of few-shot learning [48], [49] to extract visual attributes from a given sample by quantifying its similarity to the enrolled samples. Thus effectively tackling the challenge of training models to

recognize and generalize from a limited number of labeled examples per class. Similar to the writer-dependent module this module also follows the same sequence of layers (i.e convolution layer being followed by BatchNormalization and ReLU).

In context of the present work, the weights of the Siamese network is trained on the Omniglot dataset [50] details of which is elaborated in section V. The decision to utilize the language-independent Omniglot dataset [50] is derived from its diverse collection of characters sourced from various languages, which enhances the generalization of writer features.

### C. Classification block

The features outputted by both the writer-dependent and writer-independent blocks are combined and then sent to a classification block, which includes a Global Average Pooling (GAP) layer, a dropout layer, and a fully connected layer. Before reaching the classification module, the combined output undergoes a convolution operation, which serves as a bottleneck layer to obtain a lower-dimensional representation of the input feature. Such a configuration is intended to decrease the quantity of trainable parameters, thereby mitigating the risk of overfitting the network.

## V. ATTENTION MODULE

Given the constrained receptive field of convolutional operators, addressing long-range dependencies requires traversing multiple convolutional layers. However, learning these dependencies presents challenges on several fronts: smaller models may lack the capacity to adequately capture them, optimization algorithms often struggle to optimize parameters across multiple layers, and parameter configurations intended to capture these dependencies. While enlarging the convolution kernels can enhance the network’s representational prowess, it comes at the cost of sacrificing the computational efficiencies.

In response to the challenges posed by capturing intricate dependencies within data, attention mechanisms have emerged as transformative tools in deep neural networks. These mechanisms empower models to attentively prioritize elements within input data, assigning degrees of significance to different areas. Such adaptability markedly enhances the model’s proficiency in recognizing intricate patterns and connections, facilitating more efficient feature acquisition. Our proposed model integrates the self-attention module introduced by *et.al.* [51] to capture long-range dependencies within writer fragments.

In contrast to conventional attention mechanisms that rely on external context to assess various segments of an input sequence, self-attention focuses on evaluating the internal relationships within the sequence directly. This is accomplished through a series of mathematical operations applied to the convolution output, allowing the model to determine attention scores for each element in relation to every other element within the sequence itself. Subsequently, these attention scores are leveraged to compute weighted sums of the input sequence, effectively capturing the contextual dependencies between its elements.

The features from the previous convolution layer  $\mathbf{x} \in \mathbb{R}^{N \times C}$  are first transformed into feature spaces  $\mathbf{f}(\mathbf{x}) = \mathbf{W}_f \mathbf{x}$  and  $\mathbf{g}(\mathbf{x}) = \mathbf{W}_g \mathbf{x}$ , to calculate attention weight as follows:

$$\beta_{j,i} = \frac{\exp(s_{ij})}{\sum_{i=1}^N \exp(s_{ij})} \quad (1)$$

Where,  $S_{ij} = \mathbf{f}(\mathbf{x}_i)^T \mathbf{g}(\mathbf{x}_j)$  and  $\beta_{j,i}$  is the attention weights for each pair of input  $i$  and output at position  $j$ . Here  $C$  and  $N$  represent the number of channels and number of feature locations of features from the previous layers respectively. These attention weights are subsequently incorporated to obtain the final output  $\mathbf{o} = (\mathbf{o}_1, \mathbf{o}_2, \dots, \mathbf{o}_j, \dots, \mathbf{o}_N) \in \mathbb{R}^{N \times C}$  based on the below formulation:

$$\begin{aligned} \mathbf{o}_j &= \mathbf{v} \left( \sum_{i=1}^N \beta_{j,i} \mathbf{h}(\mathbf{x}_i) \right) \\ \mathbf{h}(\mathbf{x}_i) &= \mathbf{W}_h \mathbf{x}_i \\ \mathbf{v}(\mathbf{x}_i) &= \mathbf{W}_v \mathbf{x}_i \end{aligned} \quad (2)$$

Furthermore, the module conducts an additional operation of scaling the output of the attention layer and then adding it back to the input feature map. Representing the final output as:

$$\mathbf{y}_i = \gamma \mathbf{o}_i + \mathbf{x}_i \quad (3)$$

The learning parameter  $\gamma$  facilitates the network’s initial focus on cues within the simpler local neighborhood, gradually shifting towards giving more weight to non-local evidence over time. Figure 4 displays the configuration of the attention module. In our proposed research, we have explored two configurations of the attention module, depending on the sequence in which it is attached to the convolution block. These configurations are illustrated in Figure 5. A comprehensive examination of these configurations is conducted in Section VII.

## VI. CNN MODEL TRAINING AND TESTING PROCESS

The segment extracted from the word image serves as input to the unified model, incorporating both the writer-dependent and writer-independent modules. The writer-dependent module concentrates on capturing intricate details associated with the writer at the character and sub-character levels, refining its weights iteratively solely from the writer fragments.

In contrast, as the primary objective of the writer-independent block is to capture general features of the writer. It is trained using transfer learning, where the weights of this module are frozen up to the second residual block, using the pre-trained weights acquired from the Omniglot dataset (as elaborated in Section IV-B), while the weights of the third residual block onwards are fine-tuned based on input fragments.

The weights of the resulting network is updated using the label smoothing cross-entropy loss function [52]. This technique converts the hard label ( $y_i$ ) into soft labels ( $\hat{y}_i$ ) by employing a weighted average between the uniform distribution and the hard label.

$$\hat{y}_i = y_i(1 - \epsilon) + \frac{\epsilon}{K} \begin{cases} 1 - \epsilon, & i = target \\ \frac{\epsilon}{K}, & i \neq target \end{cases} \quad (4)$$

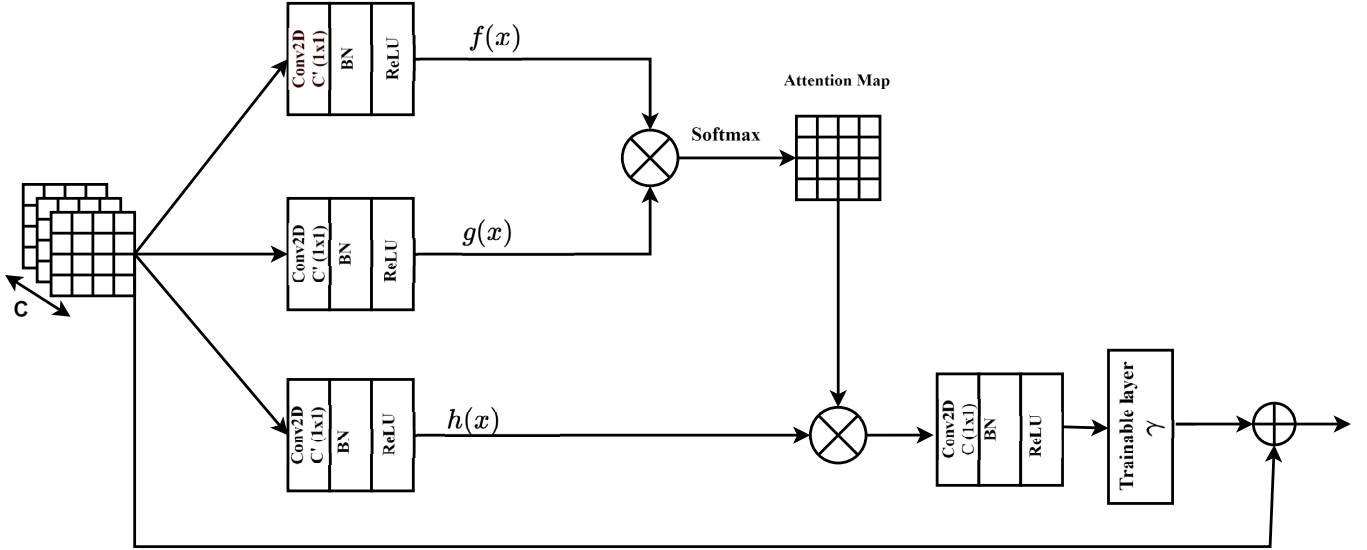

Fig. 4: Block diagram of the CNN-based Attention module. The entries after the convolution block represented by  $C'(1 \times 1)$  and  $C(1 \times 1)$  indicate the quantity and configuration of the convolution filters, with BN denoting the batch normalization block.

Here,  $K$  and  $\epsilon$  denote the number of classes and the label smoothing factor respectively. With this approach, the total loss is obtained by computing the cross-entropy loss between the predicted label and the adjusted ground truth label, formulated as follows:

$$L_i = - \sum_j^M \hat{y}_{ij} \cdot \log(p_{ij}) \quad (5)$$

Where  $M$  is the number of writers in the training set, while  $\hat{y}_{ij}$  and  $p_{ij}$  denote the modified ground truth and the predicted label respectively, for the  $i^{th}$  fragment corresponding to the  $j^{th}$  writer. The overall training loss is then computed as  $L = \frac{\sum_i^B L_i}{B}$ , where  $B$  represents the number of word fragments.

In the testing phase, given a word image  $w$  yielding  $n_T$  word fragments. The writer evidence  $P_i(w)$  for the word ( $w$ ) associated with the  $i^{th}$  writer is computed by averaging the responses corresponding to all  $n_T$  word fragments of the queried word.

$$P_i(w) = \frac{\sum_{k=1}^{n_T} p_{ki}}{n_T} \quad (6)$$

Here,  $p_{ki}$  denotes the individual classification score of the  $k^{th}$  fragment corresponding to the  $i^{th}$  writer. The final predictor is made based on the classifier label ( $i$ ) for which the highest classification score is obtained.

$$\phi(w) = \underset{i \in \{1, \dots, W\}}{\operatorname{argmax}} P_i(w) \quad (7)$$

## VII. EXPERIMENTS

### A. Dataset Description

The proposed method is evaluated on three datasets: IAM [53], CVL [54] and CERUG-EN [22].

- The IAM database contains handwriting samples collected from 657 writers. Each writer has contributed a variable number of handwritten documents, 301 writers have contributed more than two handwritten documents while the rest have contributed only one handwritten document. In our implementation the IAM dataset is modified as described in [55]. For writers contributing more than one page of a handwritten document, we randomly select two pages, of which one page is used for training and the other for testing. For writers with only one page of a handwritten document, we split it roughly into two halves. One half is used for training and the other half for testing. We utilize the bounding box information for the used images provided in the dataset to generate the training and test samples.
- The CVL dataset contains handwritten documents collected from 310 writers of which 27 writers have contributed 7 documents (6 in English and 1 in German) and the rest 284 have contributed 5 documents (4 in English and 1 in German). In our experiment, we utilized only handwritten English documents. We follow the same methodology as is done in [36], by selecting three documents per writer for training and the fourth for testing. Similar to the IAM dataset, segmented word images are made available in this dataset.
- The CERUG-EN dataset is a collection of handwritten documents from 105 subjects, with two English paragraphs contributed by each subject. In our experiment, the first paragraph written by each subject is used for testing and the second paragraph is used for training. The authors of [22] make the segmented word images accessible in the database, just like the IAM and CVL databases.

The segmented word images of enrolled writers are included in IAM and CVL databases. However, in the case of CERUG-EN database, the segmentation was done manually by the

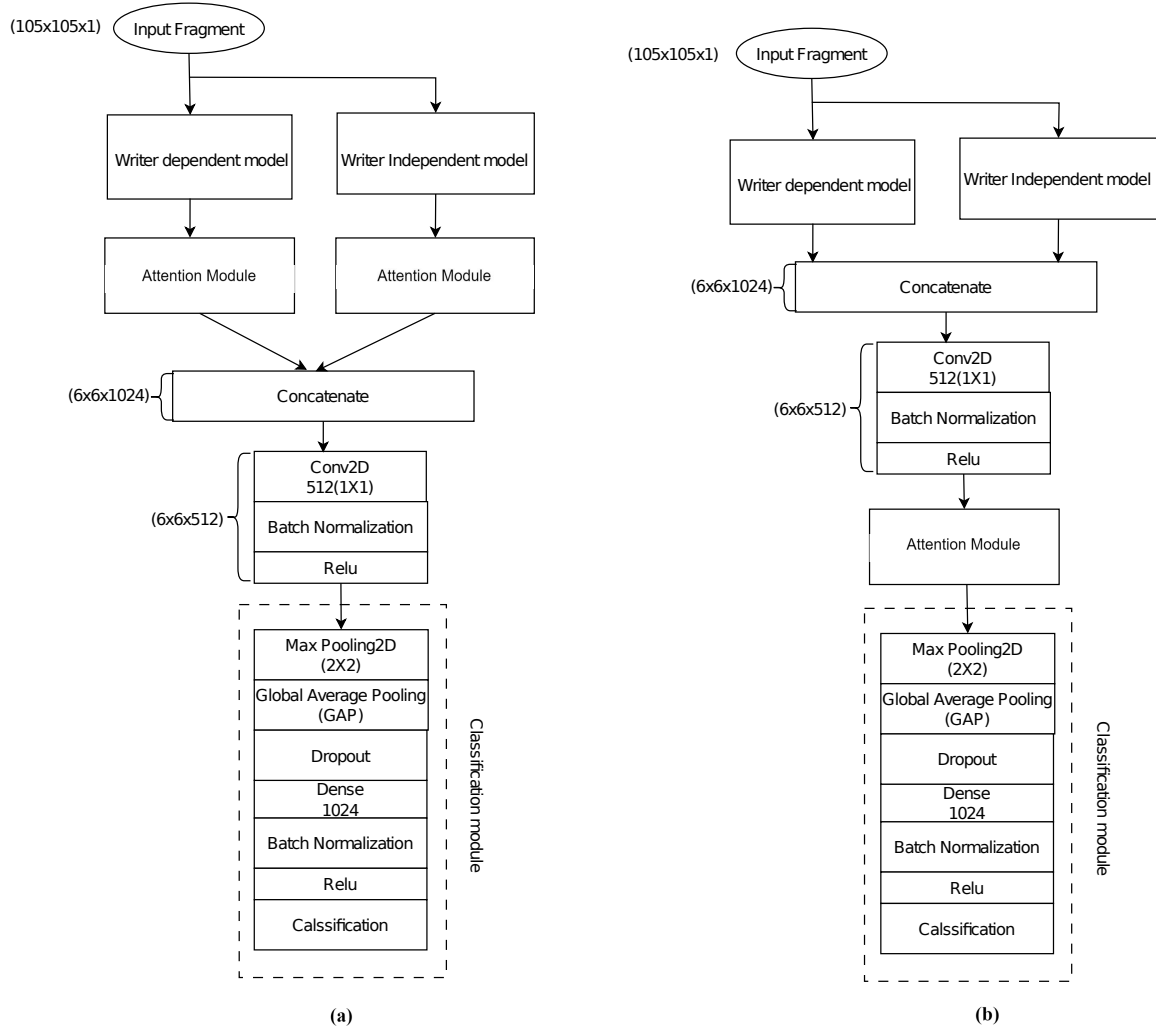

Fig. 5: Block diagram representing different configurations of attention module. Figure (a) the attention module is incorporated with each writer dependent and independent modules. In Figure (b) the attention module is incorporated with the output of the combined feature map.

TABLE I: Overview of the datasets used in experiments

Dataset	Number of writers	Language
IAM	657	English
CVL	310	English
CERUG-EN	105	English

authors of [36]. Table I gives a detailed overview of the datasets used in our experiments, and Figure 6 shows some of the training samples of the dataset.

### B. Pre-Processing

As an initial preprocessing step, all the word images are first converted into grayscale. Owing to the fact that segmented word images are used as input in our proposed system the common noise source associated with the page image such as inkblots, extraneous masks etc. is mostly taken care of during the word segmentation process. However, some lighting and background issue is observed in the segmented Images of IAM and CERUG-EN database. To cater to this issue, a two-stage

operation is performed. An input image is first filtered using  $(5 \times 5)$  Gaussian kernel following which Otsu thresholding is applied. The resulting filtered word image thus generated is shown in Figure 7.

### C. Implementation Details

Our Convolution Neural Network is implemented on TensorFlow framework. The batch size is set to 16 during training. The network is optimized using Adam optimizer [56] with an initial learning rate of 0.001 and weight decay factor of 0.5 provided the validation accuracy has stopped improving for 5 epochs continuously. The number of epochs is set to 150. The label smoothing factor  $\epsilon$  used in equation 4 is set to 0.1.

### D. Ablation Study

In this segment, an ablation analysis is conducted to evaluate the effectiveness of different modules integrated into the suggested convolution network for classifying writer samples. As part of this investigation, the impact of adding various modules

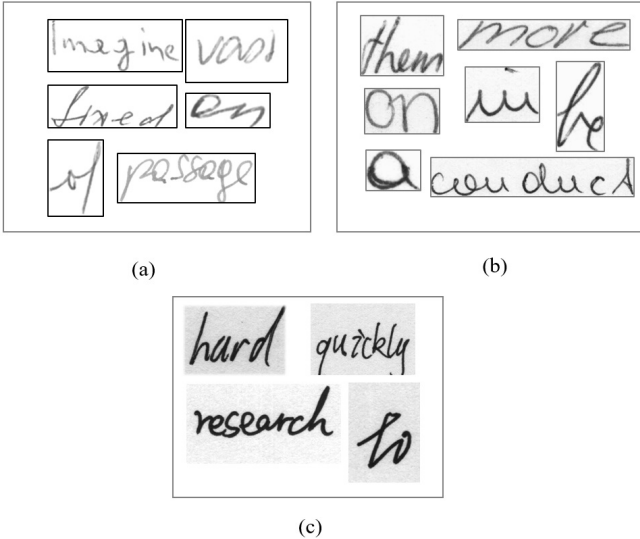

Fig. 6: Examples of training samples in (a) CVL database, (b) IAM database, and (c) CERUG-EN database.

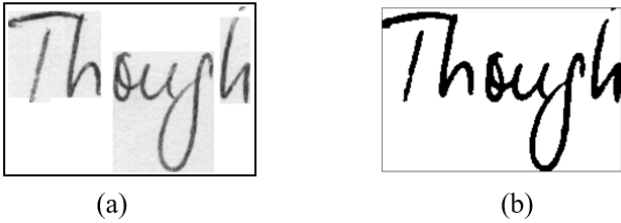

Fig. 7: Image depicting the result of the preprocessing operation carried out to remove background noise. (a) Raw input image, and (b) preprocessed image output.

is examined, assessing its effects on the overall performance of the proposed system.

In the first set of experiment, a comparison is made between the baseline network, constructed exclusively using the writer-dependent module in the convolution network, and the combined model created by integrating the writer-independent module into the baseline configuration. Table II displays the Top1 and Top5 accuracy for these configurations. On evaluating the outcomes of II, it becomes evident that the integration of the writer-independent module with the baseline configuration enhances the overall system performance across all three databases. This finding reinforces our observation that the inclusion of the writer-independent module enhances the system’s capability to generalize writer features, consequently resulting in an overall performance enhancement.

In the following experiment, we investigate how integrating the attention module impacts the overall system performance. As part of this experiment, we explore two configurations for incorporating the attention module (as illustrated in Figure 5). In each configuration, the size of the attention modules is systematically varied from  $C/8$  to  $C/2$ , doubling it with each subsequent step. Here,  $C$  denotes the number of convolution channels preceding the attention module. The objective of this experiment is to examine the influence of the positioning

and size of the attention module on the overall system performance. The outcomes of this investigation are elaborated in Table III. As per the table, it’s clear that integrating the attention mechanism impacts the overall system performance. Accuracy experiences notable enhancement for attention head sizes of 64, 128, and 128, aligning with IAM, CVL, and CERUG-EN datasets respectively. Moreover, upon comparison of the two attention configurations, no significant performance change is detected. Therefore, for memory efficiency, we opt for the configuration that incorporates the attention mechanism with the combined feature map, with attention heads of size 64, 128, and 128 to IAM, CVL, and CERUG-EN respectively, for subsequent evaluations.

TABLE II: Table showing the effect of incorporating a writer-independent module on the performance of neural networks trained on image fragments.

Database	IAM		CVL		CERUG-EN	
	Top1	Top5	Top1	Top5	Top1	Top5
Baseline	92.87	96.13	91.00	96.95	97.47	99.85
Combined	93.43	96.35	91.71	97.08	97.62	99.90

#### E. Performance comparison of feature representation with prior works

In this experiment, we evaluate the effectiveness of feature representation learned by the proposed convolution module for writer identification and compare it with other handcrafted features as well as deep-learning-based methods. In this setup, the fragment extracted from a word image using the SIFT algorithm corresponding to each writer’s training samples is passed through the proposed network. The penultimate layer output of this network serves as the feature representation. These feature representations, derived from each fragment linked to a writer’s word image in the training datasets, is then employed to train a one-class SVM classifier tailored to the respective writer being analyzed.

Each SVM classifier assigns a value to the input fragment depending on its proximity to the separating hyperplane. The obtained values are then bounded between  $[0 - 1]$  by passing them through a sigmoid function. Following this, the final classification score is generated by accumulating the individual score generated for each fragment across trained SVM classifiers.

$$P_i(word) = \frac{1}{n_t} \sum_{j=1}^{n_T} p_j^i \quad (8)$$

Here,  $p_j^i$  represents the classification score of  $j^{th}$  fragment generated by an SVM classifier trained on samples of the  $i^{th}$  writer.  $P_i(word)$  represents the overall classification score obtained for an input word image containing  $n_T$  number of fragments.

The final predictor is made based on the classifier label ( $i$ ) for which the highest classification score is obtained.

$$\phi(w) = \underset{i \in \{1, \dots, W\}}{\operatorname{argmax}} P_i(word) \quad (9)$$



TABLE III: Table illustrating the Impact of Integrating the Attention Mechanism on Overall System Performance across two Configurations as depicted in Figure 5.

No. of attention heads	Configuration (a)						Configuration (b)					
	IAM		CVL		CERUG-EN		IAM		CVL		CERUG-EN	
	Top1	Top5	Top1	Top5	Top1	Top5	Top1	Top5	Top1	Top5	Top1	Top5
64	94.08	96.57	91.94	97.18	97.52	99.99	93.92	96.49	91.42	97.02	97.71	99.85
128	93.70	96.44	92.07	97.24	97.71	1	93.46	96.36	92.25	97.58	97.76	99.95
256	93.63	96.49	91.81	97.08	97.33	99.95	93.70	96.46	91.68	97.18	97.75	99.90

Table IV shows the result of writer identification based on word images. From the table it can be inferred that the performance of handcrafted features based on word images is very low compared to deep learning based methods. This is owing to the fact that handcrafted features extract mostly rely on extracting statistical information from the handwritten image, which necessitates the use of large amount of text sample for obtaining a stable representation. On the other hand presence of multiple filter in deep learning based method helps it capturing diverse information from the word image, thus increasing the overall performance of the system. Moreover, when compared with other deep learning-based methods (i.e WordImageNet, FragNet-64, GR-RNN and its variants) our proposed algorithm and its variants (indicated in bold) achieves better accuracy across the three databases. This superiority in performance can be credited to the extraction of image fragments at various abstraction levels, allowing it to capture a wide range of information and thereby improving its overall robustness.

TABLE IV: Comparison study of effectiveness of feature representation of the proposed algorithm (indicated in bold) in terms of Writer Identification performance (in % ) on word image samples

.85Method	IAM		CVL		CERUG-EN	
	Top1	Top5	Top1	Top5	Top1	Top5
Hinge [3]	13.8	28.3	13.6	29.7	14.4	32.8
Quill [57]	23.8	44.0	23.8	46.7	24.5	51.9
CoHinge [58]	19.4	34.1	18.2	34.2	17.7	34.0
QuadHinge [58]	20.9	37.4	17.8	35.5	17.0	36.0
COLD [59]	12.3	28.3	12.4	29.0	17.3	42.2
Chain Code Pairs [20]	12.4	27.1	13.5	30.3	14.5	33.0
Chain Code Triplets [20]	16.9	33.0	17.2	35.4	17.8	38.0
WordImageNet [36]	52.4	62.5	62.5	82.0	74.3	94.6
FragNet-64 [36]	72.2	88.0	79.2	93.3	75.9	94.7
Vertical GR-RNN(FGRR) [37]	83.3	94.0	83.5	94.6	70.2	91.6
Horizontal GR-RNN(FGRR) [37]	82.4	93.8	82.9	94.6	68.9	90.9
<b>Proposed Baseline Method</b>	88.6	94.5	85.6	95.1	96.1	99.8
<b>Combined</b>	89.1	94.9	86.9	95.6	96.8	99.9
<b>Combined with attention</b>	90.3	95.0	87.9	96.2	97.1	99.9

#### F. Performance evaluation of Writer Identification system within and cross-Datasets

In this section, we study the effectiveness of the feature representation learned by the proposed network across and within a dataset. This analysis aids in understanding the impact of integrating two modules: the Writer-Independent module and the Attention block, on the learned feature representation in contrast to the baseline method. Consequently, this assists us in evaluating the robustness of the learned feature representation.

Given a trained Convolution network, we extract the feature from its penultimate layer and evaluate the model perfor-

mance. In the within-dataset evaluation, features are extracted by the network trained with samples from the same dataset. Conversely, in cross-dataset evaluation, features are extracted by the network trained on samples from different datasets. Following this, a one-class classifier is constructed forming the basis for the final decision-making process as elaborated in section VII-E.

The result of this analysis is shown in Figure 8. Based on the figure it can be observed that the optimal performance is achieved when the dataset used for feature extraction aligns with the dataset employed for network training. In such instances, the network effectively captures writer-specific features, and the accuracy consistently follows the general trend of the model incorporating an attention mechanism, showcasing the highest performance compared to the other two models. However, in the cross-dataset scenario, we see a departure from this trend as the combined model surpasses the attention-based model. This discrepancy arises due to the attention module’s property of selectively focusing on specific regions or features within the input data, potentially resulting in a loss of generality. This observation can be substantiated by visualizing the heat map projection of the convolution layer just before the fully connected layer corresponding to the three configurations as shown in Figure 9. The figure clearly shows that, in contrast to the baseline, the other two configurations capture additional data features, as highlighted by the red box corresponding to the region indicated by the yellow box in the input image. However, between the two neural network configurations, the model incorporating the attention module captures more refined, data-dependent features, potentially resulting in a loss of generality across datasets and impacting its overall performance.

#### G. Performance of proposed system with word images of different lengths

To examine how the proposed model adapts to variations in word length, we conducted an experiment assessing its performance on word images spanning from two to ten characters. Figure 10 shows the Top1 performance of writer identification for different word lengths on the IAM and CVL datasets. The results reveal a notable reduction in the algorithm’s sensitivity to words with more than three characters. This reduction is attributed to the limited textual content in word images containing fewer than four characters, hindering the model’s ability to accurately capture a writer’s characteristics and resulting in lower accuracy compared to word images with more than three characters. Moreover, for the two databases

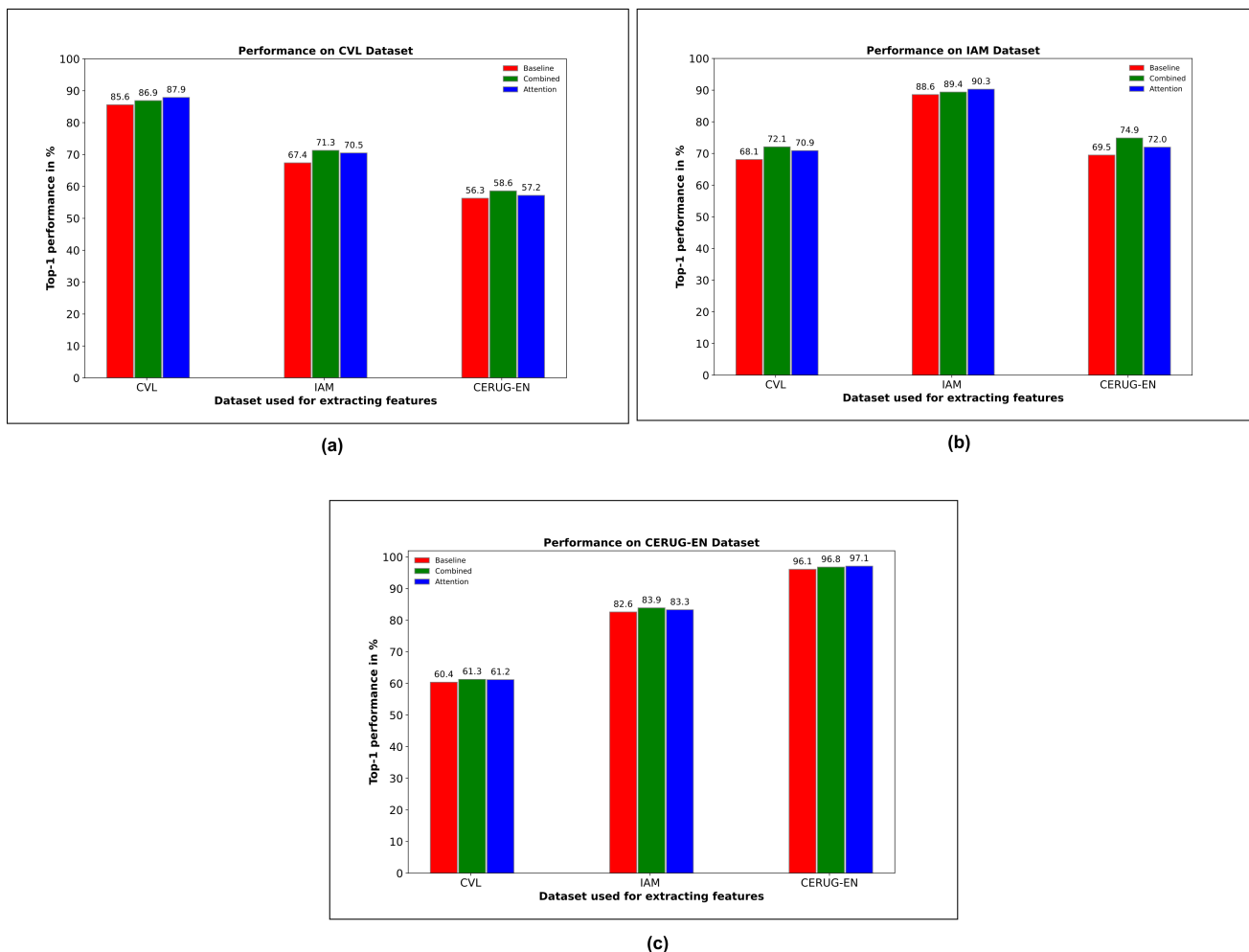

Fig. 8: The performance of writer identification based on word images by features extracted from neural networks trained on different data sets.

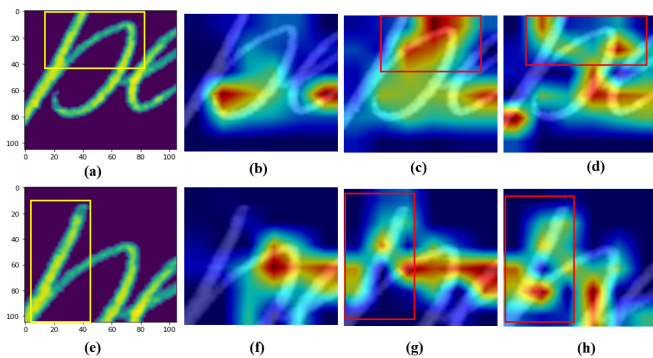

Fig. 9: Heat map projection of the word fragment corresponding to the three configurations. Figure pairs ((a), (e)), ((b), (f)), ((c), (g)), and ((d), (h)) represent the input word fragment and the heat map projection of the fragment corresponding to the three configurations namely baseline, combined, and combine with attention modules respectively. The rectangular region in an image indicated by yellow and red indicates the region of an image in the query image and its corresponding heat-map projection.

under consideration, the attention-based model provides better results than the other two configurations.

#### H. Performance comparison with other end-to-end deep neural networks

TABLE V: Performance comparison (in %) with existing Deep neural networks methods on word data.

Method	IAM		CVL		CERUG-EN	
	Top1	Top5	Top1	Top5	Top1	Top5
Deep-Adaptive [35]	69.5	86.1	79.1	93.7	-	-
WordImageNet [36]	81.8	94.1	88.6	96.8	77.3	96.4
Fragnet-64 [36]	85.1	95.0	90.2	97.5	77.5	95.6
Vertical GR-RNN(FGRR) [37]	85.9	95.2	92.6	97.9	82.6	95.8
Horizontal GR-RNN(FGRR) [37]	86.1	95.0	92.4	97.8	83.2	96.2
RSTC [41]	90.7	96.6	92.7	97.9	-	-
<b>Combined with attention</b>	<b>93.8</b>	<b>97.4</b>	<b>92.3</b>	<b>97.3</b>	<b>97.7</b>	<b>99.9</b>

In this experiment, we compare the performance of the proposed end-to-end network with other similar networks trained on word images. Table V shows the result of the experiment across three datasets. Our proposed method performs better than other deep-learning models across the three datasets. However, for the CERUG-EN dataset, a major improvement

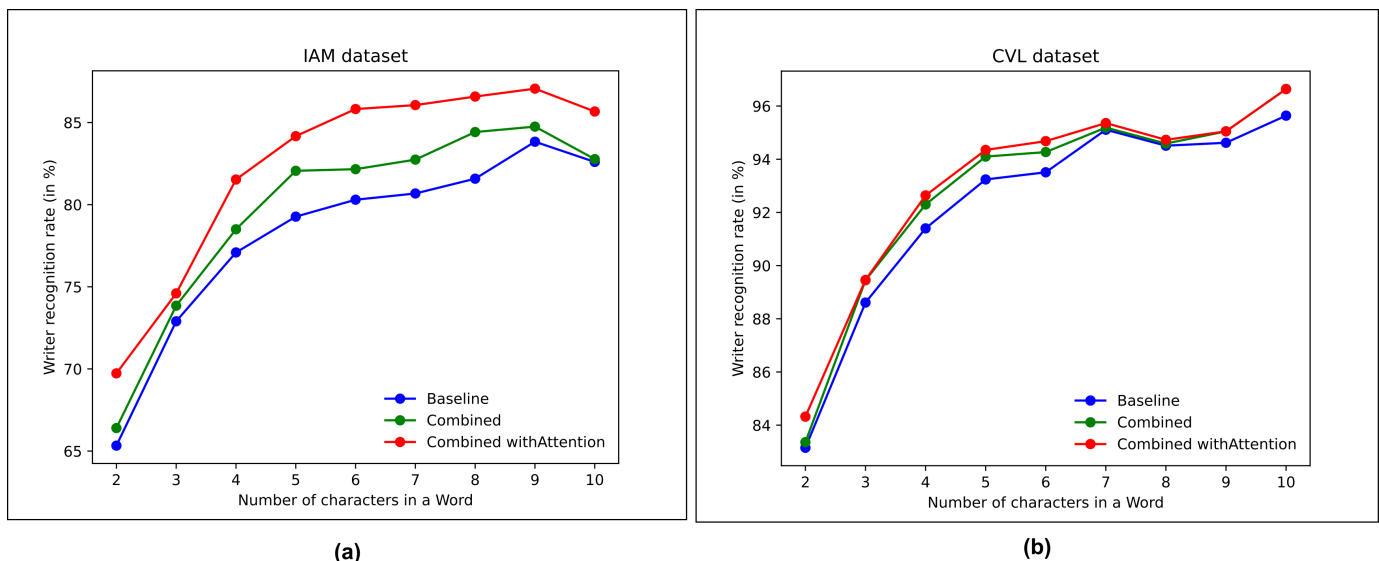

Fig. 10: Performance (Top1) of writer identification with word images containing variable number of characters tested on (a) IAM, and (b) CVL Dataset.

TABLE VI: Table showing the computation efficiency of the proposed algorithm in terms of the number of parameters and FLOPs computed with respect to the IAM dataset (with 657 writers)

Model	Flops (G)
FragNet [36]	7.14
GR-RNN [37]	6.73
Baseline	0.45
Combined	1.01
Combined with attention (configuration (b))	1.03

in accuracy is observed. This is owing to the fact that most of the prior deep-learning networks are trained on word-level data either considering the whole word as an entity as in WordImageNet [36] or extracting the fragments obtained from the feature maps [36], [37] to make the final classification decision leading to limited feature learning. On the contrary, our proposed model is trained on word fragments that encompass keypoints, capturing features across various levels of resolution through a pyramidal-based methodology. This approach empowers the network to more effectively learn feature mappings, consequently leading to a notable improvement in overall accuracy.

Furthermore, in order to showcase the computational efficiency of our proposed network, we provide the count of floating-point operations (FLOPs) for each variant of our model on the IAM dataset. We compare these figures against those of other end-to-end convolution-based models. The results are detailed in Table VI. From Table V and VI, it becomes apparent that not only does our proposed model and its iterations surpass other convolution-based end-to-end models in accuracy, but also in computational efficiency.

## VIII. CONCLUSION

In this paper, we proposed a multi-channel convolution-based End-to-end network for offline text-independent writer identification systems centred on word images. The proposed network combines writer-specific local features with writer-independent global features to generate a robust representation of writer features. Additionally, we also explore the impact of incorporating an attention mechanism on the overall system performance. Based on the experimental result it is observed that the network trained on individual fragments performs better compared to those trained on word images or a combination of word fragments in limited sample scenarios.

## REFERENCES

- [1] W. Chi, J. Wang, and M. Q.-H. Meng, "A gait recognition method for human following in service robots," *IEEE Transactions on Systems, Man, and Cybernetics: Systems*, vol. 48, no. 9, pp. 1429–1440, 2018.
- [2] R. Fernandez-de Sevilla, F. Alonso-Fernandez, J. Fierrez, and J. Ortega-Garcia, "Forensic writer identification using allographic features," in *2010 12th International Conference on Frontiers in Handwriting Recognition*, 2010, pp. 308–313.
- [3] M. Bulacu, R. van Koert, L. Schomaker, and T. van der Zant, "Layout analysis of handwritten historical documents for searching the archive of the cabinet of the dutch queen," in *Ninth International Conference on Document Analysis and Recognition (ICDAR 2007)*, vol. 1, 2007, pp. 357–361.
- [4] S. He, P. Sammara, J. Burgers, and L. Schomaker, "Towards style-based dating of historical documents," in *2014 14th International Conference on Frontiers in Handwriting Recognition*, 2014, pp. 265–270.
- [5] M. Faundez-Zanuy, J. Fierrez, M. Ferrer, M. Diaz, R. Tolosana, and R. Plamondon, "Handwriting biometrics: Applications and future trends in e-security and e-health," *Cognitive Computation*, vol. 12, 09 2020.
- [6] A. Rehman, S. Naz, M. I. Razzak, and I. A. Hameed, "Automatic visual features for writer identification: A deep learning approach," *IEEE Access*, vol. 7, pp. 17 149–17 157, 2019.
- [7] H. Said, T. Tan, and K. Baker, "Personal identification based on handwriting," *Pattern Recognition*, vol. 33, no. 1, pp. 149–160, 2000.
- [8] B. Helli and M. E. Moghaddam, "A text-independent persian writer identification based on feature relation graph (frg)," *Pattern Recogn.*, vol. 43, no. 6, p. 2199–2209, jun 2010.
- [9] Z. He, X. You, and Y. Y. Tang, "Writer identification using global wavelet-based features," *Neurocomput.*, vol. 71, no. 10–12, p. 1832–1841, jun 2008.

- [10] C. Shen, X.-G. Ruan, and T.-L. Mao, "Writer identification using gabor wavelet," in *Proceedings of the 4th World Congress on Intelligent Control and Automation (Cat. No.02EX527)*, vol. 3, 2002, pp. 2061–2064 vol.3.
- [11] D. Bertolini, L. Soares de Oliveira, E. Justino, and R. Sabourin, "Texture-based descriptors for writer identification and verification," *Expert Systems with Applications*, vol. 40, p. 2069–2080, 05 2013.
- [12] Y. Hannad, I. Siddiqi, and Y. Elkettani, "Writer identification using texture descriptors of handwritten fragments," *Expert Systems with Applications*, vol. 47, pp. 14–22, 11 2016.
- [13] D. Chawki and S.-M. Labiba, "A texture based approach for arabic writer identification and verification," in *2010 International Conference on Machine and Web Intelligence*, 2010, pp. 115–120.
- [14] A. J. Newell and L. D. Griffin, "Writer identification using oriented basic image features and the delta encoding," *Pattern Recogn.*, vol. 47, no. 6, p. 2255–2265, Jun. 2014.
- [15] G. Abdeljalil, C. Djeddi, I. Siddiqi, and S. Al-Maadeed, "Writer identification on historical documents using oriented basic image features," in *2018 16th International Conference on Frontiers in Handwriting Recognition (ICFHR)*. IEEE, 2018, pp. 369–373.
- [16] L. Schomaker, K. Franke, and M. Bulacu, "Using codebooks of fragmented connected-component contours in forensic and historic writer identification," *Pattern Recognition Letters*, vol. 28, pp. 719–727, 04 2007.
- [17] L. Schomaker and M. Bulacu, "Automatic writer identification using connected-component contours and edge-based features of uppercase western script," *IEEE Transactions on Pattern Analysis and Machine Intelligence*, vol. 26, no. 6, pp. 787–798, 2004.
- [18] M. Khemakhem and M. Kheakhem, "A model-based approach to offline text-independent arabic writer identification and verification," *Pattern Recognition*, vol. 48, 10 2014.
- [19] A. Bensefia, T. Paquet, and L. Heutte, "A writer identification and verification system," *Pattern Recognition Letters*, vol. 26, pp. 2080–2092, 10 2005.
- [20] I. Siddiqi and N. Vincent, "Text independent writer recognition using redundant writing patterns with contour-based orientation and curvature features," *Pattern Recognition*, vol. 43, pp. 3853–3865, 11 2010.
- [21] G. Ghiasi and R. Safabakhsh, "Offline text-independent writer identification using codebook and efficient code extraction methods," *Image and Vision Computing*, vol. 31, p. 379–391, 05 2013.
- [22] L. Schomaker, M. Wiering, and H. Sheng, "Junction detection in handwritten documents and its application to writer identification," *Pattern Recognition*, vol. 48, 06 2015.
- [23] R. Jain and D. Doermann, "Offline writer identification using k-adjacent segments," in *2011 International Conference on Document Analysis and Recognition*, 2011, pp. 769–773.
- [24] Y. Tangl, X. Wu, and W. Bu, "Offline text-independent writer identification using stroke fragment and contour based features," *Proceedings of 2013 International Conference on Biometrics*, pp. 1–6, 01 2013.
- [25] E. Khalifa, S. A. Al-Maadeed, M. A. Tahir, A. Bouridane, and A. Jamshed, "Off-line writer identification using an ensemble of grapheme codebook features," *Pattern Recognit. Lett.*, vol. 59, pp. 18–25, 2015.
- [26] S. Fiel and R. Sablatnig, "Writer identification and retrieval using a convolutional neural network," in *International Conference on Computer Analysis of Images and Patterns*. Springer, 2015, pp. 26–37.
- [27] V. Christlein, D. Bernecker, A. Maier, and E. Angelopoulou, "Offline writer identification using convolutional neural network activation features," in *German Conference on Pattern Recognition*. Springer, 2015, pp. 540–552.
- [28] V. Christlein, M. Gropp, S. Fiel, and A. Maier, "Unsupervised feature learning for writer identification and writer retrieval," in *2017 14th IAPR International Conference on Document Analysis and Recognition (ICDAR)*, vol. 1. IEEE, 2017, pp. 991–997.
- [29] V. Christlein, D. Bernecker, F. Hnig, A. Maier, and E. Angelopoulou, "Writer identification using gmm supervectors and exemplar-svms," *Pattern Recogn.*, vol. 63, no. C, p. 258–267, Mar. 2017.
- [30] S. Chen, Y. Wang, C.-T. Lin, W. Ding, and Z. Cao, "Semi-supervised feature learning for improving writer identification," *Information Sciences*, vol. 482, pp. 156–170, 2019.
- [31] A. Sulaiman, K. Omar, M. F. Nasrudin, and A. Arram, "Length independent writer identification based on the fusion of deep and hand-crafted descriptors," *IEEE Access*, vol. 7, pp. 91 772–91 784, 2019.
- [32] A. Semma, Y. Hannad, I. Siddiqi, S. Lazrak, and Y. Elkettani, "Feature learning and encoding for multi-script writer identification," *International Journal on Document Analysis and Recognition (IJDAR)*, 02 2022.
- [33] W. Yang, L. Jin, and M. Liu, "Deepwriterid: An end-to-end online text-independent writer identification system," *IEEE Intelligent Systems*, vol. 31, no. 2, pp. 45–53, 2016.
- [34] L. Xing and Y. Qiao, "Deepwriter: A multi-stream deep cnn for text-independent writer identification," in *2016 15th International Conference on Frontiers in Handwriting Recognition (ICFHR)*, 2016, pp. 584–589.
- [35] H. Sheng and L. Schomaker, "Deep adaptive learning for writer identification based on single handwritten word images," *Pattern Recognition*, vol. 88, 11 2018.
- [36] S. He and L. Schomaker, "Fragnet: Writer identification using deep fragment networks," *IEEE Transactions on Information Forensics and Security*, vol. 15, pp. 3013–3022, 2020.
- [37] S. He and L. Schomaker, "Gr-rnn: Global-context residual recurrent neural networks for writer identification," *Pattern Recognit.*, vol. 117, p. 107975, 2021.
- [38] M. A. Shaikh, T. Duan, M. Chauhan, and S. N. Srihari, "Attention based writer independent verification," in *2020 17th International Conference on Frontiers in Handwriting Recognition (ICFHR)*, 2020, pp. 373–379.
- [39] Z. Chen, H.-X. Yu, A. Wu, and W.-S. Zheng, "Letter-Level Online Writer Identification," *International Journal of Computer Vision*, vol. 129, 05 2021.
- [40] T. Ngo, H. Nguyen, and M. Nakagawa, *A-VLAD: An End-to-End Attention-Based Neural Network for Writer Identification in Historical Documents*, 09 2021, pp. 396–409.
- [41] P. Zhang, "Rstc: A new residual swin transformer for offline word-level writer identification," *IEEE Access*, vol. 10, pp. 57 452–57 460, 2022.
- [42] D. G. Lowe, "Distinctive image features from scale-invariant keypoints," *Int. J. Comput. Vision*, vol. 60, no. 2, p. 91–110, Nov. 2004.
- [43] S. Ruder, "An overview of multi-task learning in deep neural networks," *arXiv preprint arXiv:1706.05098*, 2017.
- [44] M. Javidi and M. Jampour, "A deep learning framework for text-independent writer identification," *Engineering Applications of Artificial Intelligence*, vol. 95, p. 103912, 09 2020.
- [45] A. Semma, Y. Hannad, I. Siddiqi, C. Djeddi, and M. E. Y. El Kettani, "Writer identification using deep learning with fast keypoints and harris corner detector," *Expert Systems with Applications*, vol. 184, p. 115473, 2021.
- [46] H. Nguyen, C. Nguyen, T. Ino, B. Indurkha, and M. Nakagawa, "Text-independent writer identification using convolutional neural network," *Pattern Recognition Letters*, vol. 121, 07 2018.
- [47] A. G. Howard, M. Zhu, B. Chen, D. Kalenichenko, W. Wang, T. Weyand, M. Andreetto, and H. Adam, "Mobilenets: Efficient convolutional neural networks for mobile vision applications," *arXiv preprint arXiv:1704.04861*, 2017.
- [48] L. Fei-Fei, R. Fergus, and P. Perona, "One-shot learning of object categories," *IEEE Transactions on Pattern Analysis and Machine Intelligence*, vol. 28, no. 4, pp. 594–611, 2006.
- [49] B. Lake, R. Salakhutdinov, J. Gross, and J. Tenenbaum, "One shot learning of simple visual concepts," in *Proceedings of the 33rd Annual Conference of the Cognitive Science Society*, 2011.
- [50] B. M. Lake, R. Salakhutdinov, and J. B. Tenenbaum, "Human-level concept learning through probabilistic program induction," *Science*, vol. 350, no. 6266, pp. 1332–1338, 2015.
- [51] H. Zhang, I. Goodfellow, D. Metaxas, and A. Odena, "Self-attention generative adversarial networks," in *International conference on machine learning*. PMLR, 2019, pp. 7354–7363.
- [52] C. Szegedy, V. Vanhoucke, S. Ioffe, J. Shlens, and Z. Wojna, "Rethinking the inception architecture for computer vision," in *Proceedings of the IEEE conference on computer vision and pattern recognition*, 2016, pp. 2818–2826.
- [53] U.-V. Marti and H. Bunke, "The iam-database: An english sentence database for offline handwriting recognition," *International Journal on Document Analysis and Recognition*, vol. 5, pp. 39–46, 11 2002.
- [54] F. Kleber, S. Fiel, M. Diem, and R. Sablatnig, "Cvl-database: An off-line database for writer retrieval, writer identification and word spotting," in *2013 12th International Conference on Document Analysis and Recognition*, 2013, pp. 560–564.
- [55] X. Wu, Y. Tang, and W. Bu, "Offline text-independent writer identification based on scale invariant feature transform," *IEEE Transactions on Information Forensics and Security*, vol. 9, no. 3, pp. 526–536, 2014.
- [56] D. P. Kingma and J. Ba, "Adam: A method for stochastic optimization," *arXiv preprint arXiv:1412.6980*, 2014.
- [57] A. Brink, J. Smit, M. Bulacu, and L. Schomaker, "Writer identification using directional ink-trace width measurements," *Pattern Recognition*, vol. 45, pp. 162–171, 01 2012.

- [58] H. Sheng and L. Schomaker, "Beyond ocr: Multi-faceted understanding of handwritten document characteristics," *Pattern Recognition*, vol. 63, pp. 321–333, 03 2017.
- [59] H. Sheng and L. Schomaker, "Writer identification using curvature-free features," *Pattern Recognition*, vol. 63, p. 451–464, 09 2016.