

Advanced Artificial Intelligence Algorithms in Cochlear Implants: Review of Healthcare Strategies, Challenges, and Perspectives

Billel Essaid^a, Hamza Kheddar^a, Noureddine Batel^a, Abderrahmane Lakas^b and Muhammad E. H. Chowdhury^c

^aLSEA Laboratory, Department of Electrical Engineering, University of Medea, 26000, Algeria

^bCollege of Information Technology, United Arab Emirates University, Al Ain P.O. Box 17551, United Arab Emirates

^cDepartment of Electrical Engineering, Qatar University, Doha 2713, Qatar

ARTICLE INFO

Keywords:

Profound hearing loss
Postoperative cochlear implant
Speech therapy rehabilitation
Cochlear implant
Automatic speech recognition
Machine learning

ABSTRACT

Automatic speech recognition (ASR) plays a pivotal role in our daily lives, offering utility not only for interacting with machines but also for facilitating communication for individuals with either partial or profound hearing impairments. The process involves receiving the speech signal in analogue form, followed by various signal processing algorithms to make it compatible with devices of limited capacity, such as cochlear implants (CIs). Unfortunately, these implants, equipped with a finite number of electrodes, often result in speech distortion during synthesis. Despite efforts by researchers to enhance received speech quality using various state-of-the-art signal processing techniques, challenges persist, especially in scenarios involving multiple sources of speech, environmental noise, and other circumstances. The advent of new artificial intelligence (AI) methods has ushered in cutting-edge strategies to address the limitations and difficulties associated with traditional signal processing techniques dedicated to CIs. This review aims to comprehensively review advancements in CI-based ASR and speech enhancement, among other related aspects. The primary objective is to provide a thorough overview of metrics and datasets, exploring the capabilities of AI algorithms in this biomedical field, summarizing and commenting on the best results obtained. Additionally, the review will delve into potential applications and suggest future directions to bridge existing research gaps in this domain.

1. Introduction

In the symphony of modern technology, automatic speech recognition (ASR) emerges as a master, orchestrating a seamless interaction between humans and machines. This transformative technology has quietly become an integral part of our daily lives, influencing how we communicate, access information, and even navigate the intricacies of healthcare. The significance of ASR extends beyond its role in facilitating human-computer interaction; it permeates diverse applications such as voice assistants and virtual agents, speech-to-text conversion, identity verification, and holds particular promise in the realm of biomedical research [1, 2]. ASR bridges the gap between spoken language and digital communication, enabling the conversion of spoken words into written text with remarkable accuracy. The pervasiveness of ASR technology is evident in the devices we use daily—smartphones, smart speakers, and voice-activated virtual assistants—all seamlessly responding to our spoken commands and queries. The convenience it brings to our lives is undeniable, offering a hands-free and efficient mode of interaction that has become second nature.

ASR is pivotal in authentication systems, safeguarding the security and privacy of sensitive information. The integrity of audio speech can be verified through techniques-based ASR such as adversarial attacks detections [3], steganalysis [4–6], speech biometric [7] and more. Beyond the realm of communication, ASR finds itself at the heart of various applications, each playing a unique role in different domains. *Speaker recognition*, a facet of ASR, is not merely confined to enhancing security measures. It has evolved into a versatile tool employed in healthcare, where the identification of individuals through their unique vocal signatures holds promise for personalized patient care. This is particularly relevant in scenarios where quick and secure authentication is crucial, such as accessing medical records or authorizing medical procedures. *Event recognition*, another dimension of ASR, is a game-changer in sectors ranging from security to healthcare. In the former, ASR algorithms analyze audio data to automatically detect and categorize specific events, reinforcing surveillance capabilities. In healthcare, event recognition becomes a powerful tool for monitoring and early detection of health-related events. For instance, in the context of cardiac health, ASR can aid in identifying anomalies in heart sounds, potentially enabling early intervention and preventive measures [8]. *Source separation*, the ability to discern and isolate individual sound sources from complex audio signals, is a boon in fields like entertainment and music production. However, its significance extends into the realm of biomedical research, where ASR plays a pivotal role in decoding the intricate language of physiological signals. In the context of cochlear implants (CIs), source separation becomes a critical component in enhancing the auditory experience for individuals with hearing impairments.

The CIs are designed to restore hearing in individuals with severe hearing loss or deafness, rely on ASR for optimizing their functionality. ASR contributes significantly to the improvement of speech perception in CI users by enhancing the processing and interpretation of auditory signals. CIs work by converting sound waves into electrical signals that stimulate the auditory nerve,

* The first is the corresponding author.

✉ essaidbill@gmail.com (B. Essaid); kheddar.hamza@univ-medea.dz (H. Kheddar); batelnour@gmail.com (N. Batel); alakas@uaeu.ac.ae (A. Lakas); mchowdhury@qu.edu.qa (M.E.H. Chowdhury)

ORCID(s):

Acronyms and Abbreviations

CNN	convolutional neural network	MFCC	mel-frequency cepstral coefficient	ILD	interaural level difference
AI	artificial intelligent	GFCC	gammatone frequency cepstral coefficient	SDR	source-to-distortion ratio
DL	deep learning	LSTM	long short term memory	SAR	source-to-artifact ratio
CI	cochlear implant	ASR	automatic speech recognition	SIR	source-to-interference ratio
ML	machine learning	DNN	deep neural networks	dB	decibel
FCN	fully convolutional neural networks	CS	channel selection	MIMO	multiple-input multiple-output
STOI	short time objective intelligibility	RNN	recurrent neural network	EVD	eigenvector decomposition
MMSE	minimum mean square error	GAN	generative adversarial network	ReLU	rectified linear unit
DDAE	deep denoising auto-encoder	PESQ	perceptual estimation of speech quality	RNN	recurrent neural network
SNR	signal to noise ratio	KLT	karhunen-loève transform	MICE	multiple imputation by chained equations
EAS	electric and acoustic stimulation	DAE	deep autoencoder	ECochG	intracochlear electrocochleography
CGRU	convolutional recurrent neural network with gated recurrent units	ICA	intra cochlear anatomy	CM	cochlear microphonic
CWT	continuous wavelet transform	ST	scala tympani	FFR	frequency following responses
GRU	gated recurrent units	SV	scala vestibul	f_0	fundamental frequency
IGCIP	image guided cochlear implant programming	AR	active region	TFSC	temporal fine structure cues
CT	computed tomography	ASM	active shape model	RMSE	root mean square error
OCT	optical coherence tomography	NR	noise reduction	BM	basilar-membrane
MEE	mean endpoint error	Res-CA	residual channel attention	ROI	regions of interest
Acc	Accuracy	GCPFE	global context-aware pyramid feature extraction	DRL	deep reinforcement learning
Sen	Sensitivity	ACE-Loss	active contour with elastic loss	RL	reinforcement learning
Spe	Specificity	DS	deep supervision	FOX	fitting to outcomes expert
Pre	Precision	UHR	ultra-high-resolution	MHINT	mandarin of hearing in noise test
Rec	Recall	ESCSO	enhanced swarm-based crow search optimization	BCP	bern cocktail party
F1	F1 score	cGAN	conditional generative adversarial networks	EST	effective stimulation threshold
NCM	normalized covariance measure	P2PE	point to point error	ECAP	electrically evoked compound action potential
FFT	fast Fourier transform	ASE	average surface error	MRI	magnetic resonance imaging
ACE	advanced combination encoder	MARGAN	metal artifact reduction based generative adversarial networks	BSS	blind source separation
MMS	min-max similarity	ESCSO	enhanced swarm based crow search optimization	AEP	auditory evoked potential
ROC	receiver operating characteristic curve	EEG	electroencephalography	CCA	canonical correlation analysis
NCM	normalized covariance measure	ERP	event-related potential	ASE	average surface error
DCS	dice coefficient similarity	DRNN	deep recurrent neural networks	STOI	short-time objective intelligibility
ASD	average surface distance	MLP	multilayer perceptrons	TL	transfer learning
AVD	average volume difference	NMF	non-negative matrix factorization	CIS	continuous interleaved sampling
IoU	intersection over union	DCAE	deep convolutional auto-encoders	DTL	deep transfer learning
MAE	mean absolute error			FL	federated learning
VAE	variational autoencoders			CTC	connectionist temporal classification
CAE	convolutional autoencoder			BERT	bidirectional encoder representations from transformer
AE	autoencoder				
SOTA	state-of-the-art				

bypassing damaged parts of the inner ear. ASR complements this process by aiding in the recognition and translation of spoken language. The technology plays a crucial role in optimizing speech understanding for CI users by refining the interpretation of varied speech patterns, tones, and nuances. Moreover, ASR in the context of CIs extends beyond basic speech recognition. It contributes to the recognition of environmental sounds, facilitating a more immersive auditory experience for individuals with hearing impairments. This is particularly significant in enhancing the quality of life for CI recipients, allowing them to navigate and engage with their surroundings more effectively.

1.1. Related work

Many reviews have been written in the context of CI. For example, [9] discussed the advantages offered by machine learning (ML) to cochlear implantation, such as analyzing data to personalize treatment strategies. It enhances accuracy in speech processing optimization, surgical anatomy location prediction, and electrode placement discrimination. Besides, it delves into its applications, including optimizing cochlear implant fitting, predicting patient threshold levels, and automating image-guided CI surgery. The review discusses some open novel opportunities for research, emphasizing the need for high-quality data inputs and addressing concerns about algorithm transparency in clinical decision-making for improved patient care. Similarly, the review written by Manero et al. [10] details some benefits of employing artificial intelligent (AI) in enhancing CI technology, involving adaptive sound processing, acoustic scene classification, and auditory scene analysis. The authors discuss AI-driven advancements aiming to optimize sound signals, adapt to diverse environments, and improve speech perception for individuals with hearing loss, ultimately enhancing their overall quality of life. Also, the review [11] explores three main topics: direct-speech neuroprosthesis, which involves decoding speech from the sensorimotor cortex using AI, including the synthesis of produced speech from brain activity.

Table 1

Comparison of this review against other existing AI-based CI reviews and surveys. Tick marks (✓) indicate that a particular field has been considered, while cross marks (✗) indicate that a field has been left unaddressed. The symbol (★) indicates that the most critical concerns of a field have not been addressed.

Ref.	Year	Description	Backg.	TCI	Metrics	datasets	MLT	DLT	Apps	RGCs	FDs
[9]	2019	The intersection of ML and CIs	✗	✗	✗	✗	✓	✗	✓	★	★
[10]	2022	Explores materials and devices designed for medical care	✗	✗	✗	★	✗	✗	✓	✗	✗
[11]	2022	AI in otolaryngology and communication sciences	✓	✗	✗	✗	✓	✗	★	✗	✗
[12]	2022	Remote audiology services	✗	✗	✗	✗	✗	✗	✓	✗	✗
[13]	2023	Signal processing in CI for noise reduction	✓	✗	✗	✗	✓	✗	★	✗	★
Our	2024	Advanced AI algorithms for CIs	✓	✓	✓	✓	✓	✓	✓	✓	✓

Abbreviations: Taxonomy in CI (TCI), ML-based techniques (MLT), DL-based techniques (DLT), Applications (apps), Research gaps and challenges (RGCs), Future directions (FDs)

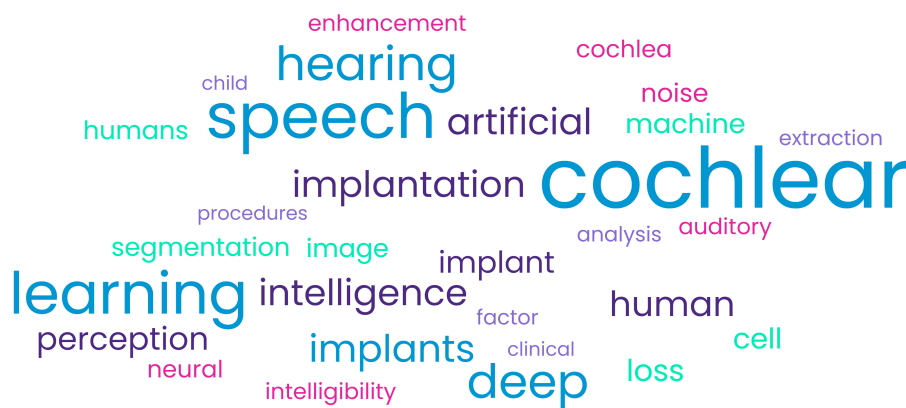
**Figure 1:** Top keywords in AI-based CI research field.

The second topic is a top-down exploration of pediatric cochlear implantation using ML, delving into the applications of ML in pediatric cochlear implantation. Lastly, the paper considers the potential of AI to solve the hearing-in-noise problem, examining its capabilities in addressing challenges related to hearing in noisy environments. Moreover, the review [12] critically examines the current landscape of tele-audiology practices, highlighting both their constraints and potential opportunities. Specifically, it explores intervention and rehabilitation efforts for CIs, focusing on remote programming and the concept of self-fitting CIs. Recently, a review written by Henry et al. in 2023 [13] conducts a comprehensive review of noise reduction algorithms employed in CIs. Maintaining a general classification based on the number of microphones used—single or multiple channels—the analysis extends to incorporate recent studies showcasing a growing interest in ML techniques. The review culminates with an exploration of potential research avenues that hold promise for future advancements in the field. Table 1 offers a comparative analysis of the proposed review in contrast to other discussed AI-based CI reviews and surveys.

1.2. Statistics on investigated papers

Recently, there has been a surge in publications related to AI-based CI. The review methodology entails defining the search strategy and study selection criteria. Criteria for inclusion, like keyword relevance and impact, shape the quality assessment protocol. A comprehensive search was conducted on databases such as Scopus and Web of Science. Keywords were extracted for theme clustering, resulting in a formulated query to gather advanced AI-based CI studies. The research query fetches references from papers containing the keywords "Cochlear implant" or "Hearing loss" and "Artificial intelligence" in their abstracts, titles, or authors' keywords. It subsequently refines these papers, focusing on those that also include "Machine learning," "Deep learning," or "Reinforcement learning." Figure 1 illustrates the most frequently used keywords by the authors in the titles, abstracts, and keywords of the selected papers.

Figure 2 illustrates the distribution of these papers by type and publication year, encompassing articles, conference papers, and reviews. Additionally, it showcases the percentage of publications from before 2015 to 2023, with a total count of 99 papers. Notably, the peak in publications within this field is observed in 2023 (Figure 2 (a)), underscoring the heightened interest among researchers. Furthermore, the predominant publication type is research articles, followed by conference papers (Figure 2 (b)).

1.3. Motivation and contribution

The motivation behind conducting a comprehensive review on CIs stems from the imperative to critically assess and consolidate the current state of AI applications in this crucial field. CIs have revolutionized auditory rehabilitation for individuals with hearing

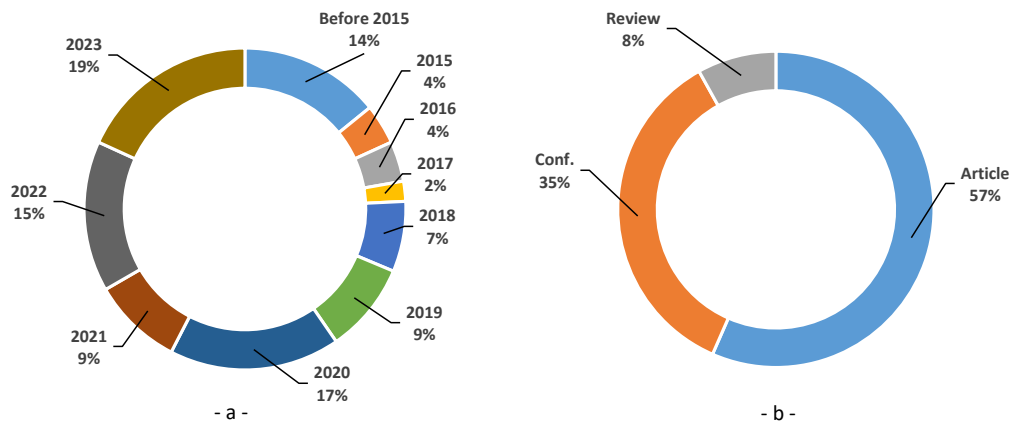

Figure 2: Bibliometrics analysis of the papers included in this review. (a) Papers distribution over the last years. (b) Percentage breakdown of paper types included in this review.

impairment, and integrating ML and deep learning (DL) techniques holds immense potential for further advancements. This review seeks to fill a significant gap in the existing literature by providing a detailed analysis of recent AI-based CI frameworks.

The primary objective is to present a nuanced understanding of the landscape, categorizing frameworks based on ML and DL methodologies, available datasets, and key metrics. By addressing this gap, the review aims to offer valuable insights for researchers, clinicians, and technologists involved in the development and improvement of CI technologies. Furthermore, the exploration of advanced DL algorithms, such as transformers and reinforcement learning (RL), in the context of CIs, underscores the potential for transformative breakthroughs. Ultimately, this research review aspires to contribute to the enhancement of CI technologies, fostering innovation and improving the quality of life for individuals with hearing impairment. The principal contributions of this paper can be succinctly outlined as follows:

- Detailing the assessment metrics associated with AI and CIs, and elucidating the extensively utilized datasets, whether publicly accessible or generated, employed to validate AI-based ASR for CI methodologies.
- The implementation of CI, along with a comprehensive elucidation of the taxonomy encompassing ML and DL-based CI, is thoroughly expounded upon. Additionally, recommended frameworks for AI-based CI are thoroughly discussed and succinctly summarized in tables for enhanced clarity.
- Providing detailed insights into the applications of ML and DL within the domain of CI, encompassing functions such as denoising and speech enhancement, segmentation, thresholding, imaging, as well as CI localization, along with various other functionalities.
- Delve into the existing gaps in AI-driven CI, offer insights, and propose novel ideas to address these gaps. Additionally, explore potential avenues for future research to deepen comprehension and provide valuable guidance for subsequent investigations.

The subsequent sections are organized as follows: Section 2 delves into the background in speech processing for, outlining datasets and metrics. Section 3 discusses the methodology employed for CI based on AI. Section 4 presents the medical applications and impact of applying AI on CI. Section 5 offers a comprehensive discussion research gaps, future directions, and perspectives. Finally, Section 6 concludes the paper with implications and future research directions.

2. Background in speech processing for CIs

2.1. Speech processing for CIs

CIs are electronic devices that can be implanted in one or both ears to restore some level of hearing for individuals with partial or severe deafness. CIs comprise an external part with a microphone and speech processor and an internal part with a receiver-stimulator and electrode array as shown in Figure 3. They convert sounds into electrical signals, stimulating the auditory nerve to enable sound perception in individuals with profound hearing loss [14].

The incoming sound is divided into multiple frequency channels using bandpass filters and then processed by envelope detectors. Non-linear compressors adjust the dynamic range of the envelope for each patient. The compressed envelope amplitudes are then utilized to modulate a fixed-rate biphasic carrier signal. A current source converts voltage into pulse trains of current, which are delivered to electrodes placed along the cochlea in a non-overlapping manner. This stimulation method is called continuous interleaved sampling (CIS). Another coding strategy, known as advanced combination encoder (ACE), uses a greater number of channels and dynamically selects the "n-of-m" bands with the largest envelope amplitudes (prior to compression). Only the corresponding "n" electrodes are stimulated. A popular device widely used for CIs, such as the cochlear nucleus, typically has 22 channels. The sound processor, which usually contains a microphone, battery, and other components, can be worn either behind-the-ear (BTE) or off-the-ear (OTE). A headpiece holds a transmitter coil, positioned externally above the ear, while internally, a

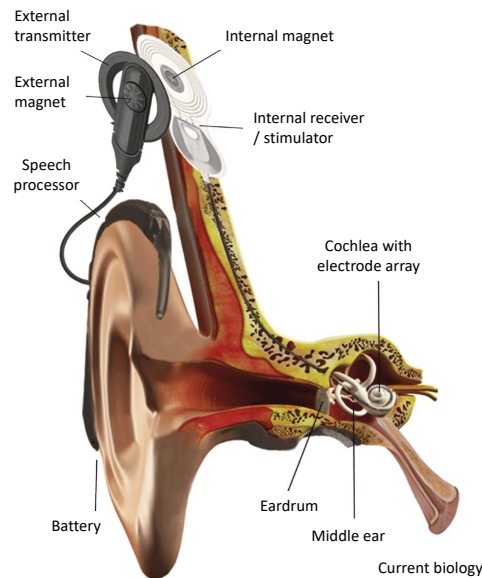

Figure 3: Illustration of a CI depicting the components situated externally and internally within the device [14]

receiver coil, stimulator, and electrode array are implanted. The SP includes a digital signal processor (DSP) with memory units (maps) that store patient-specific information. An audiologist configures these maps during the fitting process, adjusting thresholds for each electrode, including T-Levels (the softest current levels audible to the CI user) and C/M-Levels (current levels perceived as comfortably loud), as well as the stimulation rate or programming strategy. Data (pulse amplitude, pulse duration, pulse gap, etc.) and power are sent through the skull via an radio frequency signal from the transmitter coil to the receiver coil. The stimulator decodes the received bitstream and converts it into electric currents to be delivered to the cochlear electrodes. High-frequency signals stimulate electrodes near the base of the cochlea, while low-frequency signals stimulate electrodes near the apex. The CI stimulates the auditory nerve afferents, which connect to the central auditory pathways. However, compared to individuals with normal hearing (NH), CI users face more difficulties in speech perception, particularly in noisy environments. Hearing loss can be caused by various factors, including natural aging, genetic predisposition, exposure to loud sounds, and medical treatments. Damage to the hair cells in the inner ear often leads to a reduced dynamic range of hearing, as well as decreased frequency selectivity and discriminative ability in speech processing. To evaluate the effectiveness of CIs in speech perception amid noise, listening tests involving both normal hearing individuals and CI users are commonly conducted. These tests typically employ a combination of speech utterances from a recognized speech corpus and background noises like speech-weighted noise and babble. Alternatively, vocoder simulations can be utilized alongside speech intelligibility metrics. While sentence-based tests are frequently employed, other stimuli such as vowels, consonants, and phonemes are also used. As a result, noise reduction techniques are increasingly employed to enhance the performance of CIs in challenging environments [13].

2.2. Datasets

Researchers have utilized numerous datasets to validate their proposed schemes, comprising both widely recognized publicly available sets and locally generated ones. These datasets fall into two categories: speech or images. Table 2 provides a summary of these datasets, detailing their characteristics, citing studies that have utilized them, and indicating their availability through links or references.

2.3. Metrics

Multiple evaluation metrics are utilized during the training and validation of any DL models, including AI-based CI. These metrics, integral to the confusion matrix, are widely known and applicable across various data types such as speech or image. They include Accuracy (Acc), Sensitivity (Sen), Recall (Rec), Specificity (Spe), Precision (Pre), F1 score (F1), and receiver operating

¹<https://www.phonetik.uni-muenchen.de/Bas/BasPD1eng.html>

²<https://www.kaggle.com/mfekadu/darpa-timit-acousticphonetic-continuous-speech>

³<https://research.googleblog.com/2017/08/launching-speech-commands-dataset.html>

⁴<https://www.merl.com/research/highlights/deep-clustering>

⁵<https://librivox.org/>

⁶https://claritychallenge.org/clarify_CEC1_doc/docs/cec1_data

⁷<https://www.kaggle.com/datasets/chrisfilo/demand>

⁸<https://www.openslr.org/18/>

⁹<https://zenodo.org/records/3532214>

¹⁰<https://sigsep.github.io/datasets/musdb.html>

¹¹<http://headctstudy.quare.ai/dataset>

¹²<https://zenodo.org/records/7092661>

Table 2
List of publicly available datasets used for CIs applications

Dataset	NoS	NoC	Characteristics	Used by	Source
MHINT	2560	8	It is a test resource that was developed in two versions: MHINT-M for use in Mainland China and MHINT-T for use in Taiwan. The development of MHINT took into consideration the tonal nature of Mandarin, recognizing the importance of lexical tone in designing the test.	[15],[16],[17]	[18]
PhonDat 1	21587	201	It is from the Bavarian Archive For Speech Signals, contains 21.4 hours of speech data, and it is orthographically transcribed and phonemically annotated.	[19],[20]	Link ¹
TIMIT	6300	630	The dataset consists of phonemically and lexically transcribed speech from American English speakers belonging to diverse demographics and dialects. It provides comprehensive information with time-aligned orthographic, phonetic, and word transcriptions. Additionally, each utterance is accompanied by its corresponding 16-bit, 16kHz speech waveform file, ensuring a complete and detailed dataset for analysis and experimentation in ASR and acoustic-phonetic studies.	[21],[22],[23]	Link ²
GSC	18 Hours	30	The dataset was gathered using crowd-sourcing. It consists of 65,000 recordings, each lasting one second, and contains 30 brief words. Among these words, 20 commonly used ones were spoken five times by the majority of participants, while 10 other words (considered unfamiliar) were spoken only once.	[24]	Link ³
WSJ0-2mix	-	-	This dataset is a collection of mixed speech recordings that are used for speech recognition. It utilizes utterances from the Wall Street Journal (WSJ0) corpus to create these mixtures.	[25]	Link ⁴
LibriVox	547 Hours	-	The LibriVox dataset consists of sentence-aligned German audio, text, and English translations from audio books.	[22]	Link ⁵
HSM	20	30	The development of the German HSM Sentence Test aimed to provide an ample amount of test sentences for the repeated assessment of speech comprehension among CI users.	[22],[26]	[27]
CEC1	6000	24	The dataset features simulated living rooms with static sources, including a single target speaker, interferer (competing talker or noise), and a large target speech database of English sentences produced by 40 British English speakers.	[26]	Link ⁶
DEMAND	560	6	The dataset consists of 15 recordings capturing acoustic noise in various environments. These recordings were made using a 16-channel array, with microphone distances ranging from 5 cm to 21.8 cm.	[22]	Link ⁷
THCHS-30	35 Hours	50	The dataset is a free Chinese speech corpus accompanied by resources such as lexicon and language models.	[28]	Link ⁸
BCP	55938	20	The bern cocktail party (BCP) dataset contains Cocktail Party scenarios with individuals wearing CI audio processors and a head and torso simulator. Recorded in an acoustic chamber, it includes multi-channel audio, image recordings, and digitized microphone positions for each participant.	[29]	[30]
ikala	252-30s	206	The dataset comprises audio recordings consisting of vocal and backing track music with a sampling rate of 44100 Hz. Each music track is a stereo recording, where one channel contains the singing voice and the other channel contains the background music. All tracks were performed by professional musicians and featured a group of six singers, evenly split between three females and three males.	[31]	Link ⁹
MUSDB	150	4	The dataset is a collection of music tracks specifically designed for music source separation research. It consists of professionally mixed songs across various genres, with individual tracks isolated for vocals, drums, bass, and other accompaniment.	[31]	Link ¹⁰
CQ500	491	-	The dataset includes anonymized dicoms files, along with the interpretations provided by radiologists. The interpretations were conducted by three radiologists who have 8, 12, and 20 years of experience in interpreting cranial CT scans, respectively.	[32]	Link ¹¹
ECochG	21	-	The dataset captures inner ear potentials in response to acoustic stimulation, specifically focusing on cochlear implant recipients.	[33],[34],[35]	Link ¹²

Abbreviations: Number of samples (NoS), Number of classes (NoC)

characteristic curve (ROC). Moreover, different metrics play roles in prediction task. For instance, intersection over union (IoU) assesses overlap, and mean absolute error (MAE) quantifies absolute differences. For a comprehensive understanding of the metrics discussed, including their equations, refer to the details provided in [5, 36]. Other metrics that are widely used for CI are summarized in Table 3.

3. Taxonomy of CI-based AI techniques

Several artificial intelligence techniques have been employed to enhance the efficacy of CIs. While some rely on 1D data, others process information in a 2D image format. Figure 4 summarizes all AI algorithms utilized, alongside the features employed and hybrid AI methodologies. Additionally, Table 4 provides a summary of DL-based techniques utilized in CI hearing devices.

3.1. CI-based AI Implementation

CI programming involves adjusting device settings to optimize sound perception for individual users. This includes setting stimulation levels, electrode configurations, and signal processing parameters to enhance speech understanding and auditory experiences based on patient feedback and objective measures. In 2010, govaerts et al. [38] describes the development of an intelligent agent, called fitting to outcomes expert (FOX), for optimizing CI programming as described in Figure 6. The agent analyzes map settings and psycho-acoustic test results to recommend and execute modifications to improve outcomes. The tool focuses on an outcome-driven approach, reducing fitting time and improving the quality of fitting. It introduces principles of AI in the CI fitting process. The study proposed objective measures and group electrode settings as strategies to reduce fitting time.

Similarly in [39–43], all have employed FOX for programming CI. Vaerenberg et al. [39] discusses the use of FOX for programming CI sound processors in new users. FOX modifies maps based on specific outcome measures using heuristic logic and deterministic rules. The study showed positive results and optimized performance after three months of programming, with good speech audiometry and loudness scaling outcomes. The paper highlights the importance of individualized programming parameters and the need for outcome-based adjustments rather than relying solely on comfort. In [40], computer-assisted CI fitting using FOX assessed its impact on speech understanding. Results from 25 recipients showed that 84% benefited from suggested map changes,

Table 3

An overview of the metrics employed for evaluating CI methods.

Metric	Formula	Description
DCS	$\frac{2 \cdot A \cap B }{ A + B }$	The metric dice coefficient similarity (DCS) is used to evaluate the performance of the vestibule segmentation network. The Dice coefficient is a widely used similarity metric in image segmentation tasks. It measures the overlap between the predicted segmentation mask and the ground truth mask.
ASD	$\frac{\sum_{a \in S(A)} \min_{b \in S(B)}(a - b) + \sum_{b \in S(B)} \min_{a \in S(A)}(b - a)}{ S(A) + S(B) }$	Average surface distance (ASD) is a commonly used evaluation measure in medical image segmentation tasks. It quantifies the average distance between the surfaces of two segmented objects, typically the predicted segmentation and the ground truth.
AVD	$\max(d(A, B), d(B, A))$	Average volume difference (AVD) quantifies the average difference in volume between a predicted segmentation and a reference or ground truth segmentation..
SNR	$10 \log_{10} \left(\frac{\text{Signal}}{\text{Noise}} \right)_{\text{dB}}$	Signal to noise ratio (SNR) is a measure of the quality of the speech signal. It is commonly used to evaluate the quality of the stego-speech (the speech signal after the hidden information has been embedded). A lower SNR indicates that the steganography technique has introduced more distortion to the speech signal.
ASE	$\frac{\sum E_{ij}}{N}$	Is the average surface error (ASE). The distances between corresponding points on the measured surface and the reference surface are computed using $E_{ij} = I_1(i, j) - I_2(k, l) $, known as point to point error (P2PE). N is the total number of correspondence points. Normalize average error by dividing by the imaging system's dynamic range. (i, j) , and (k, l) represent pixel values in the first and second images, respectively.
ILD	$20 \log_{10} \left(\frac{L}{R} \right)$	Interaural level difference (ILD) a psychoacoustic metric, measuring sound level differences between left (L) and right (R) ears, reflects cues essential for sound localization, enhancing spatial awareness in auditory perception for directional sound source identification.
MEE	$\frac{1}{N} \sum_{i=1}^N L_i - \hat{L}_i $	Mean endpoint error (MEE) measures the average absolute difference between the true L_i and estimated \hat{L}_i endpoint locations across multiple utterances N .
MMSE	Estimator $\hat{x}_{MMSE} = E[X Y]$	Minimum mean square error (MMSE) is a statistical estimation technique used in speech enhancement to minimize the mean square error between the estimated Y and true X clean speech signals
STOI	$\frac{\sum_{t=1}^T g(t) \cdot \text{STOI}_{\text{frame}(t)}}{\sum_{t=1}^T g(t)}$	Short-time objective intelligibility (STOI) is a metric used to assess the intelligibility of time-frequency weighted noisy speech. It is based on the idea that human speech perception relies on the availability of important acoustic features in short time frames [37].
NCM		Normalized covariance measure (NCM)
SDR, SAR, and SIR	$10 \log_{10} \frac{\ s_{\text{target}}\ ^2}{\ e_{\text{total}}\ ^2}, \quad 10 \log_{10} \frac{\ s_{\text{target}} + e_{\text{inter}} + e_{\text{noise}}\ ^2}{\ e_{\text{artifacts}}\ ^2},$ $10 \log_{10} \frac{\ s_{\text{target}}\ ^2}{\ e_{\text{inter}}\ ^2}$	Source-to-distortion ratio (SDR), source-to-artifact ratio (SAR), and source-to-interference ratio (SIR) are metrics objectively assess and compare speech source-separation algorithms based on accuracy and minimization of distortions and interference. SDR gauges source separation quality by comparing true source power to introduced distortion. SAR evaluates source separation from artifacts or noise, while SIR measures the ratio of true source power to interference after separation.

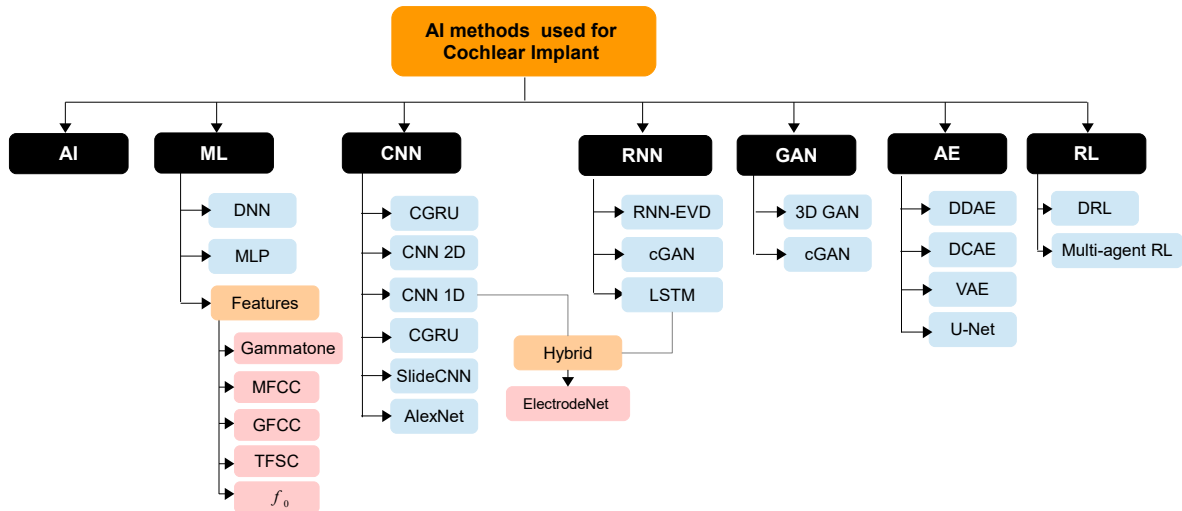
Figure 4: Taxonomy of the employed AI techniques for CI.

significantly improving speech understanding thanks to the learning capacity of FOX. This approach offers standardized, systematic CI fitting, enhancing auditory performance.

The COCH gene, referred to as the Cochlin gene, is responsible for encoding the cochlin protein situated on chromosome 14 in humans, primarily expressed in the inner ear. Cochlin predominantly functions within the cochlea, a spiral-shaped structure involved in the process of hearing, contributing to its structural integrity and proper operation. Wathour et al. in [41] discusses the use of AI in CI fitting through two case studies. The first case involves a 75-year-old lady who received a left ear implant due to gradual and severe hearing loss in both ears without a clear cause. In the second case, a 72-year-old man with a COCH gene mutation causing

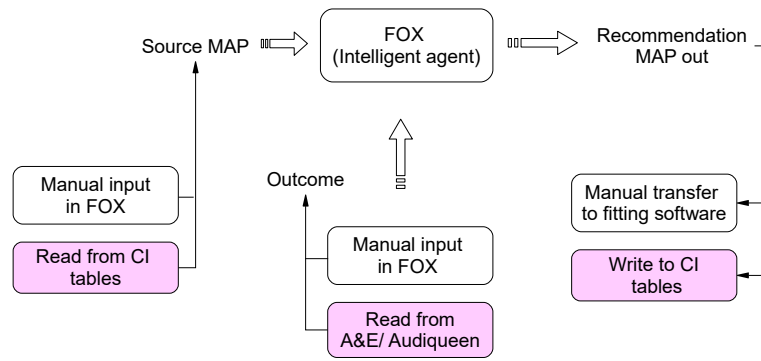

Figure 5: The fundamental operating concept of the FOX involves inputting an initial program and multiple psychoacoustic test outcomes. FOX processes this information and generates fitting suggestions as its output. When integrated with proprietary outcome and CI fitting software, the shaded boxes represent its functionality, while the unfilled boxes represent its standalone capability [38]. Audiqueen is a dataset with A and E (A&E) phoneme discrimination.

profound hearing loss in both ears underwent a right ear implant, to assess whether CI programming using the AI software FOX application, could improve CI performance. The results showed that CI-assisted fitting led to improvements in auditory outcomes for adult CI recipients who had previously undergone manual fitting. The AI suggestions helped improve word recognition scores and loudness scaling curves. Likewise, Waltzman et al. [42] incorporate AI in programming CIs, aimed to assess, on fifty-five adult's CI, the performance and standardization of AI-based programming. The results showed that the AI-based FOX for some patients performed better, while others had similar results, yet he majority preferred the FOX system.

3.2. ML-based methods

ML is a subfield of AI that focuses on developing algorithms and statistical models that enable computer systems to improve their performance in a specific task by learning features from input data. The research in [44] focuses on algorithm-based hearing and speech therapy rehabilitation after cochlear implantation, particularly for older individuals. They propose the development of an ML-based application that offers personalized hearing therapy tailored to the patient's needs, such as select exercises, adjust difficulty levels, and analyze patient difficulties. It operates independently, reducing the reliance on local speech therapists, cost-effective, and accessible alternative to traditional therapy, improving outcomes and quality of life for CI recipients. In addition, Torresen et al. [45] discusses the use of ML techniques to streamline the adjustment process for CIs. The goal is to predict optimal adjustment values for new patients based on data from previous patients. By analyzing data from 158 former patients, the study shows that while fully automatic adjustments are not possible, ML can provide a good starting point for manual adjustment. The research also identifies the most important electrodes to measure for predicting levels of other electrodes. This approach has the potential to reduce programming time, benefit patients, and improve speech recognition scores, particularly for young children and patients with post-lingual deafness. Henry et al. in their [46] investigates the importance of acoustic features in optimizing intelligibility for CIs in noisy environments. The study employs ML algorithms and extracts acoustic features from speech and noise mixtures to train a deep neural networks (DNN). The results, using various metrics, reveal that frequency domain features, particularly Gammatone features, perform best for normal hearing, while Mel spectrogram features exhibit the best overall performance for hearing impairment. The study suggests a stronger correlation between STOI and NCM in predicting intelligibility for hearing-impaired listeners. The findings can aid in designing adaptive intelligibility enhancement systems for CIs based on noise characteristics.

Moreover, the research in [47] focuses on imputing missing values in CI candidate audiometric data. This study assessed the performance of various imputation algorithms using a dataset of 7,451 audiograms from CI patients. The results showed that the quantity of missing data affected the imputation performance, with greater amounts leading to poorer results. The distribution of sparsity in the audiometric data was found to be non-uniform, with inter-octave frequencies being less commonly tested. The multiple imputation by chained equations (MICE) method, safely imputed up to six missing data points in an 11-frequency audiogram, consistently outperformed other models. This study highlights the importance of imputation techniques in maximizing datasets in hearing healthcare research. Xu et al. in [48] explores the objective discrimination of bimodal speech using frequency following responses (FFRs). The study investigates the neural encoding of fundamental frequency (f_0), called also pitch [49], and temporal fine structure cues (TFSC) in simulated bimodal speech conditions. The results show that increasing acoustic bandwidth enhances the neural representation of f_0 and TFSC components in the non-implanted ear. Moreover, ML algorithms successfully classify and discriminate FFRs based on spectral differences between vowels. The findings suggest that the enhancement of f_0 and TFSC neural encoding with increasing bandwidth is predictive of perceptual bimodal benefit in speech-in-noise tasks. FFRs may serve as a useful tool for objectively assessing individual variability in bimodal hearing. The research conducted by Crowson et al. [50] aimed to predict postoperative CI performance using supervised ML. The authors used neural networks and decision tree-based ensemble algorithms on a dataset of 1,604 adults who received CIs. They included 282 text and numerical variables related to demographics, audiometric data, and patient-reported outcomes. The results showed that the neural network model achieved a 1-year postoperative performance prediction root mean square error (RMSE) of 0.57 and classification accuracy of 95.4%. When both text and numerical variables were used, the RMSE was 25.0% and classification accuracy was 73.3%. The study identified influential variables such as preoperative sentence-test performance, age at surgery, and specific questionnaire responses. The findings suggest that supervised

ML can predict CI performance and provide insights into factors affecting outcomes. In the same context of prediction, Mikulskis et al. [51] focus on predicting the attachment of broad-spectrum pathogens to coating materials for biomedical devices as illustrated in Figure 6. The authors employ ML methods to generate quantitative predictions for pathogen attachment to a large library of polymers. This approach aims to accelerate the discovery of materials that resist bacterial biofilm formation, reducing the rate of infections associated with medical devices. The study highlights the need for new materials that prevent bacterial colonization and biofilm development, particularly in the context of antibiotic resistance. The results demonstrate the potential of ML in designing polymers with low pathogen attachment, offering promising candidate materials for implantable and indwelling medical devices. Similarly, Alohali et al. [52] focuses on using ML algorithms to predict the post-operative electrode impedances in CI patients. The study used a dataset of 80 pediatric patients and considered factors such as patient age and intraoperative electrode impedance. The results showed that the best algorithm varied by channel, with Bayesian linear regression and neural networks providing the best results for 75% of the channels. The accuracy level ranged between 83% and 100% in half of the channels one year after surgery. Additionally, the patient's age alone showed good prediction results for 50% of the channels at six months or one year after surgery, suggesting it could be a predictor of electrode impedance.

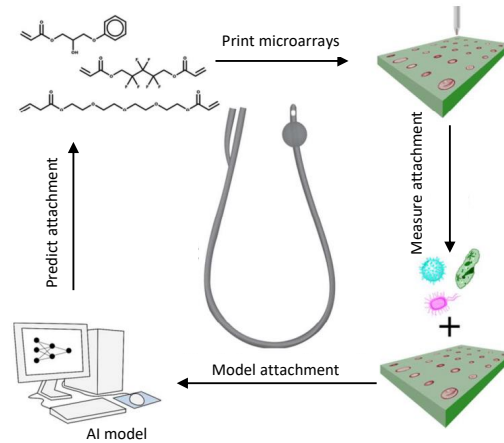

Figure 6: Diagram illustrating the procedures utilized in the production of microarrays, analysis of pathogens, data modeling, and forecasting the attachment of pathogens to novel polymers [51].

3.3. CNN-based methods

Convolutional neural networks (CNNs) are a class of DL algorithms widely used in computer vision tasks. Their architecture includes convolutional layers that automatically learn hierarchical features from input data. The core convolution for 2D data operation is defined by the equation:

$$S(i, j) = (I * K)(i, j) = \sum_m \sum_n I(m, n) \cdot K(i - m, j - n) \quad (1)$$

Here, I represents the input 2D data, K is the convolutional kernel, and S is the output feature map. CNNs excel at recognizing spatial patterns, making them essential in image recognition, object detection, and other visual tasks. Additionally, there exist 1D CNNs, which are effective for sequential data analysis, such as in natural language processing or time series applications. CNN is widely used for the interdisciplinary nature of CI, which involves aspects of neurobiology, signal processing, and medical technology. For example, the proposed work [53] introduces a novel pathological voice identification system using signal processing and DL. It employs CI models with bandpass and optimized gammatone filters to mimic human cochlear vibration patterns. The system processes speech samples and utilizes a CNN for final pathological voice identification. Results show discrimination of pathological voices with F1 scores of 77.6% (bandpass) and 78.7% (gammatone). The paper addresses voice pathology causes, compares filter models, and proposes a non-invasive, objective assessment system. It contributes to the field with a comprehensive performance analysis, achieving high accuracy and demonstrating effectiveness compared to related works. Additionally, in the scheme proposed by Wang [15], the fully convolutional neural networks (FCN) model is evaluated for enhancing speech intelligibility in mismatched training and testing conditions. Using 2,560 Mandarin utterances and 100 noise types, the study compares FCN with traditional MMSE and deep denoising auto-encoder (DDAE) models. Two sets of experiments are conducted for normal and vocoded speech. The FCN model demonstrates superior performance, maintaining clearer speech structures, especially in mid-low frequency regions crucial for intelligibility. Objective evaluations using STOI scores and a listening test confirm FCN's effectiveness under challenging SNR conditions, outperforming MMSE and DDAE. The study suggests FCN as a promising choice for electric and acoustic stimulation (EAS) speech processors.

Moving on, the research paper in [54] presents a novel approach to optimize stimulus energy for CIs. A CNN was developed as a surrogate model for a biophysical auditory nerve fiber model, significantly reducing simulation time while maintaining high accuracy. The CNN was then used in conjunction with an evolutionary algorithm [55] to optimize the shape of the stimulus waveform, resulting in energy-efficient waveforms and potential improvements in CI technology. Traditional computational models

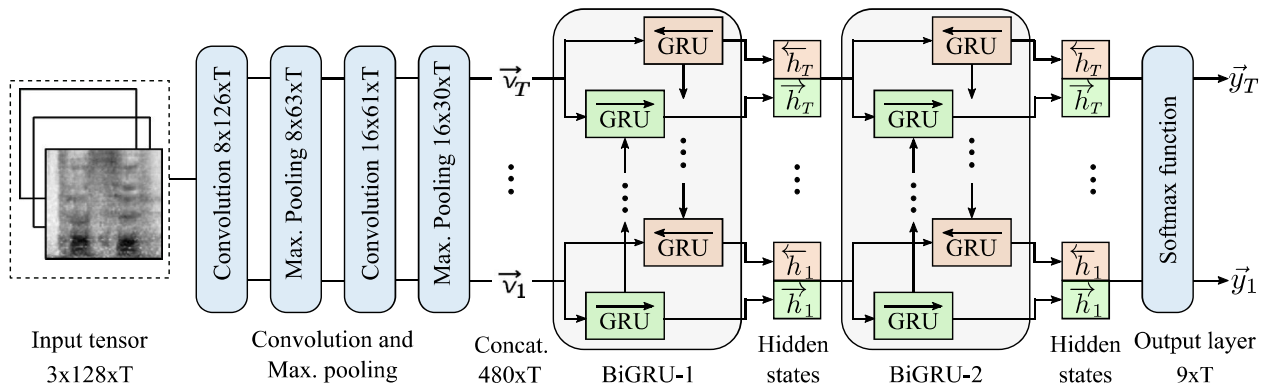

Figure 7: CGRU architecture, focusing on input sequences composed of 3D-channel data generated from Mel-spectrograms, Cochleagrams, and CWT using Morlet wavelets [19].

of the cochlea, which represent it as a transmission line, are computationally expensive due to their cascaded architecture and the inclusion of non-linearities. As a result, they are not suitable for real-time applications such as hearing aids, robotics, and ASR. For the aforementioned conditions, the study in [56] presents a hybrid approach, called CoNNear¹³, which combines CNNs, capable of performing end-to-end waveform predictions in real-time, with computational neuroscience to create a real-time model of human cochlear mechanics and filter tuning. The CNN filter weights were trained using simulated basilar-membrane (BM) displacements from cochlear channels, and the model's performance was evaluated using basic acoustic stimuli. The CoNNear model is designed to capture the tuning, level-dependence, and longitudinal coupling characteristics of human cochlear processing. It converts acoustic speech stimuli into BM displacement waveforms across 201 cochlear filters. Its computational efficiency and ability to capture human cochlear characteristics make it suitable for developing human-like machine-hearing applications.

The research paper in [24] explores the utilization of a CNN in simulating speech processing with CIs. The study investigates the effect of channel interaction, a phenomenon that degrades spectral resolution in CI delivered speech, on learning in neural networks. By modifying speech spectrograms to approximate CI delivered signals, the CNN is trained to classify them. The findings suggest that early in training, the presence of channel interaction negatively impacts performance. This indicates that the spectral degradation caused by channel interaction conflicts with perceptual expectations acquired from high-resolution speech. The study highlights the potential for reducing channel interaction to enhance learning and improve speech processing in CI users, particularly those who have adapted to high-resolution speech.

Schuerch et al. [33] focus on the objectification of intracochlear electrocochleography (ECochG) using AlexNet, CNN architecture, to automate and standardize the assessment and analysis of cochlear microphonic (CM) signals in ECochG recordings for clinical practice and research. The authors compared three different methods: correlation analysis, Hotelling's T2 test, and DL, to detect CM signals. The DL algorithm performed the best, followed closely by Hotelling's T2 test, while the correlation method slightly underperformed. The automated methods achieved excellent discrimination performance in detecting CM signals with an accuracy up to 92%, providing fast, accurate, and examiner-independent evaluation of ECochG measurements.

Moreover, Arias et al. [19] presents a methodology for speech processing using CNNs. The study aims to improve the representation learning capabilities of CNNs by combining multiple time-frequency representations of speech signals. The proposed approach involves generating multi-channel spectrograms by combining continuous wavelet transform, Mel-spectrograms, and Gammatone spectrograms. These spectrograms are utilized as input data for the CNN models. The effectiveness of the approach is evaluated in two applications: automatic detection of speech deficits in CI users and phoneme class recognition. The results demonstrate the advantages of using multi-channel spectrograms with CNNs, showcasing improved performance in speech analysis tasks. The convolutional recurrent neural network with gated recurrent units (CGRU) architecture is utilized, as illustrated in Figure 7. The input sequences consist of 3D-channel inputs created by combining Mel-spectrograms, Cochleagrams, and continuous wavelet transform (CWT) with Morlet wavelets. Convolution is applied solely on the frequency axis in order to preserve the time information. The resulting feature maps are subsequently fed into a 2-stacked bidirectional gated recurrent units (GRU). A softmax function is employed to predict the phoneme label for each speech segment in the input signal.

This paper [20] introduces a novel method for automatically detecting speech disorders in CI users using a multi-channel CNN. The model processes 2-channel input comprising Mel-scaled and Gammatone filter bank spectrograms derived from speech signals. Testing on 107 CI users and 94 healthy controls demonstrates improved performance with 2-channel spectrograms. The study addresses a gap in acoustic analysis of CI user speech, proposing a DL approach with potential applications beyond CI users. Experimental results indicate the effectiveness of the proposed CNN-based method, offering promise for speech disorder detection and potential extensions to other pathologies or paralinguistic aspects that employ mel-frequency cepstral coefficients (MFCCs) and gammatone frequency cepstral coefficient s (GFCCs) features.

For 2D CNN, the following work [57] introduces image guided cochlear implant programming (IGCIP), enhancing CI outcomes using image processing. IGCIP segments intra-cochlear anatomy in computed tomography (CT) images, aiding electrode localization for programming. The scheme addresses challenges in automating this process due to varied image acquisition protocols.

¹³https://github.com/HearingTechnology/CoNNear_periphery

The proposed solution employs a DL-based approach, utilizing CNNs to detect the presence and location of inner ears in head CT volumes. The CNNs is trained on a dataset with 95.97% classification accuracy. Results indicate potential for automatic labeling of CT images, with a focus on further 3D algorithm development. However, in [54] presents a machine-learning approach to optimize stimulus energy for CIs. A CNN was developed as a surrogate model for a biophysical auditory nerve fiber model, significantly reducing simulation time while maintaining high accuracy. The CNN was then used in conjunction with an evolutionary algorithm to optimize the shape of the stimulus waveform, resulting in energy-efficient waveforms. The proposed surrogate model offers an efficient replacement for the original model, allowing for larger-scale experiments and potential improvements in CI technology.

The work proposed by [58] introduces sliding window based CNN (SlideCNN), a novel DL approach for auditory spatial scene recognition with limited annotated data. The proposed method converts auditory spatial scenes into spectrogram images and utilizes a SlideCNN for image classification. Compared to existing models, SlideCNN achieves a significant improvement in prediction accuracy, with a 12% increase. By leveraging limited annotated samples, SlideCNN demonstrates an 85% accuracy in detecting real-life indoor and outdoor scenes. The results have practical implications for analyzing auditory scenes with limited annotated data, benefiting individuals with hearing aids and CIs.

This paper [59] focuses on advancing laser bone ablation in microsurgery using 4D optical coherence tomography (OCT). The challenge lies in automatic control without external tracking systems. The paper introduces a 2.5D scene flow estimation method using CNN for OCT images, enhancing laser ablation control. A two-stage approach involves lateral scene flow computation followed by depth flow estimation. Training is semi-supervised, combining ground truth error and reconstruction error. The method achieves a MEE of (4.7 ± 3.5) voxel, enabling markerless tracking for image guidance and automated laser ablation control in minimally invasive cochlear implantation.

3.4. GAN-based methods

A GAN is a type of AI model consisting of two neural networks, a generator, and a discriminator, engaged in a competitive learning process as presented in Figure 8.

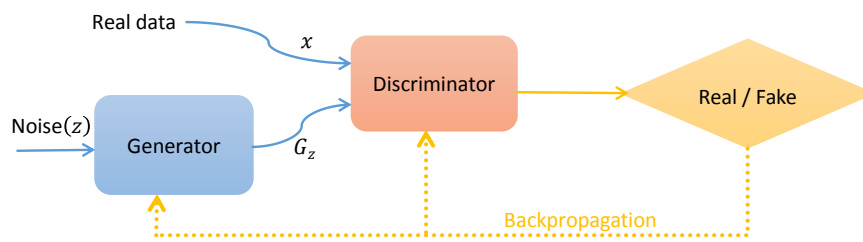

Figure 8: Illustrative depiction of a standard GAN.

The generator aims to create realistic data, such as images, while the discriminator tries to differentiate between real and generated samples. This adversarial training dynamic leads to the refinement of the generator's output, generating increasingly authentic data. The objective is for the generator to produce data that is indistinguishable from real samples. The training process is represented by the minimax game framework, with the GAN objective function given by:

$$\min_G \max_D V(D, G) = \mathbb{E}_{x \sim p_{\text{data}}(x)} [\log D(x)] + \mathbb{E}_{z \sim p_z(z)} [\log(1 - D(G(z)))] \quad (2)$$

In the GAN objective function, $\mathbb{E}_{x \sim p_{\text{data}}(x)}$ and $\mathbb{E}_{z \sim p_z(z)}$ indicate the expected values over real data samples x and noise samples z , respectively. G generates samples, D discriminates between real and generated samples, p_{data} and p_z are the distributions of real data and noise, respectively. Using GAN, the research in [68] proposes a DL-based method for reducing metal artifacts in post-operative CT imaging. The method utilizes a 3D-GAN trained on a large number of pre-operative images with simulated metal artifacts. The GAN generates artifact-free images by reducing the metal artifacts. The effectiveness of the method is evaluated quantitatively and qualitatively, showing promising results compared to classical artifact reduction algorithms. The approach overcomes the challenges of post-operative assessment of cochlear implantation caused by metal artifacts, and it does not require registration of pre and post-operative images. The 3D-GAN improves spatial consistency and is applicable to various types of artifacts. In addition, Wang et al. in their paper [62], proposes a 3D metal artifact reduction algorithm for post-operative high-resolution CT imaging. The algorithm is based on a GAN that uses simulated physically realistic CT metal artifacts created by CI electrodes. The generated images are used to train the network for artifact reduction. The metal artifact reduction-GAN based method as described in [62], utilizes a three-step process for reducing metal artifacts. Firstly, a simulation is performed to replicate CI positioning. Secondly, a physical simulation of CI metal artifacts is conducted. Lastly, a 3D GAN is trained using both simulated and preoperative datasets. The generator component of the GAN generates an image that has reduced metal artifacts, while the discriminator network is responsible for determining whether the input image contains metal artifacts or not. The method was evaluated on clinical CT images of CI postoperative cases and outperformed other general metal artifact reduction approaches. The paper introduces a novel approach that combines the physical simulation of metal artifacts with 3D-GAN, providing a promising solution for improving the visual assessment of post-operative imaging in CT.

¹⁴https://github.com/AngeLouCN/Min_Max_Similarity

Table 4

Summary of some proposed methods based on different DL techniques. When comparing the work with numerous existing schemes, only the best-performing one will be highlighted.

Ref.	DL method	Domain	Dataset	Explanation	CTODLM	Best performance	Improvement
[15]	FCN	Speech	MHINT	Experiment the effectiveness of FCN in restoring clean speech signals from noisy counterparts and enhancing the intelligibility of speech in EAS devices.	DDAE	STOI=0.85 (SNR=9dB)	STOI=+0.03
[19]	CGRU	Speech	PhonDat 1	Using of onset and offset transitions in speech analysis and The input sequences are 3D-channel inputs	CGRU	Pre=0.68 ± 0.22 Rec=0.69 ± 0.21 F1=0.69 ± 0.19	—
[59]	CNN	Image	Created	Multiple stages and follows a pyramidal network architecture inspired by SPyNet, which is designed for optical flow estimation.	—	MEE=4.7± 3.5	—
[20]	multi-channel CNN	Speech	PhonDat 1	Developing a methodology for the automatic detection of speech disorders in CI users using a 2D-channel CNN.	SVM	Acc=83.4, Sen=91.7, Spe=78.7	Acc=+0.6, Sen=-1.8, Spe=+2.7
[16]	DDAE	Speech	MHINT	The architecture of the DDAE model consisting of five layers with 500 neurons each. Objective evaluations were conducted using STOI and NCM, and a listening test (PESQ)	KLT	NCM=0.25 (SNR=9dB) STOI=0.85 (SNR=12dB)	STOI=+0.07
[60]	Res-CA	Image	Created	Introduces Res-CA block, GCPFE, ACE loss, and DS mechanism to enhance the DAE's performance and robustness for compressing CI stimulation patterns.	3D-DSD	DCS=89.91±1.77 ASD=0.13 AVD=0.14 DCS=0.920	DCS=+0.24 ASD=+0.05 AVD=-0.04 DCS=+0.032
[61]	MMS ¹⁴	Image	Created	The classifiers extract features to create negative pairs, while projectors transform unlabeled predictions into high-dimensional features to measure pixel-wise consistency.	TransUNet	IoU=0.861 MAE=0.021 F1=0.925	IoU=+0.021 MAE=-0.01 F1=+0.012
[62]	MARGAN	Image	Created	MARGAN is a 3D generative adversarial network (GAN)-based approach that uses simulated training data to reduce metal artifacts in CT images.	marLI	RMSE =0.12 PSNR= 18.31 SSIM= 0.64	RMSE=-0.03 PSNR=+1.78 SSIM=+0.08
[63]	cGAN	Image	Created	Active shape model-based method used for segmenting intra-cochlear anatomical structures.	—	ASE=0.173	ASE=-50%
[25]	MIMO-TasNet using RNN	Speech	WSJ0-2mix, ITA, DE-MAND	A speech separation framework using TasNet and recurrent neural network (RNN)-eigenvector decomposition (EVD) to preserve spatial cues for CI users.	MIMO-TasNet	Δ ILD=0.38 decibel (dB)	Δ ILD=-0.69 dB
[31]	DNN	Speech	iKala, MUSDB	A DNN algorithm enhances music perception for CI users, addressing pitch and timbre limitations. Objective measurements and listener experiments reveal preferences for enhanced vocals.	—	SDR=8dB (with iKala) SDR=5.5dB (with MUSDB) Acc=98 (gesture recognition)	—
[64]	Hybrid DNN	Speech	Created	Hearing training system consists of a speech training database, automatic lip-reading using a hybrid neural network, comparison of lip shapes, and providing a standard lip-reading sequence.	—	Acc=87 (lip-reading recognition)	—
[65]	ESCSO-based LSTM	ERP of EEG	Created	LSTM-ESCSO is a method that combines long short term memory (LSTM) network with enhanced swarm based crow search optimization (ESCSO) to improve the performance of predicting CI scores.	LSTM	Acc=96.03	Acc=+7.14
[66]	FOX	Speech	Created	The study investigates the utilization of AI in remote CI fitting, demonstrates the feasibility of AI-based fitting with remote supervision, highlighting its potential for streamlining the fitting process.	Manual fitting	66% performed better with FOX	—
[43]	FOX	Speech	Created	A study comparing manual and computer-assisted CI fitting.	Manual fitting	82% performed better with FOX	—
[67]	FOX	Speech	Created	Examined the impact of an AI-based CI programming tool on experienced CI patients. The AI-generated CI map led to improved auditory outcomes.	Manual fitting	89% preferring FOX's map	—

Abbreviations: Project link (PL), Not available (NA), Compared to other DL methods (CTODLM).

Similarly, for CI metal artifacts reduction also, a conditional generative adversarial networks (cGAN) were proposed by Wang et al. [63]. The approach involves training a cGAN to learn mapping from artifact-affected CTs to artifact-free CTs. During inference, the cGAN generated CT images with removed artifacts. Additionally, a band-wise normalization method was proposed as a preprocessing step to improve the performance of cGAN. The method was evaluated on post-implantation CTs recipients, and the quality of the artifact-corrected images was quantitatively assessed using P2PE. The results demonstrate promising artifact reduction, outperforming the previously proposed techniques. The authors evaluate the quality of artifact-corrected images using a quantitative metric based on segmentations of intracochlear anatomical structures. Specifically, the segmentation results obtained from a previously published method were compared between real preimplantation CTs and artifact-corrected CTs generated by the proposed method. The ASE was used as a metric to assess the accuracy of the segmentation. The paper reports that the proposed method achieves an ASE of 0.18 mm, which is approximately half of the error obtained with a previously proposed technique.

3.5. RNN/LSTM-based methods

RNNs are a class of artificial neural networks designed for sequential data processing. They maintain hidden state information that is updated at each time step, allowing them to capture temporal dependencies. The hidden state at time t , denoted as h_t , is computed based on the input x_t , the previous hidden state h_{t-1} , and model parameters W and U , with b representing the bias term. The equations governing the hidden state update are given by:

$$h_t = \sigma(Wx_t + Uh_{t-1} + b) \quad (3)$$

where, σ is an activation function, typically the hyperbolic tangent or rectified linear unit (ReLU). Several speech processing techniques that utilize CI are based on RNNs.

CI users struggle with music perception, and many studies have shown that enhancing music vocals improves their enjoyment. The study described by Gajęcki. et al. [69] explores source separation algorithms to remix pop songs by emphasizing the lead-singing voice. Deep convolutional auto-encoders (DCAE), deep recurrent neural networks (DRNN), multilayer perceptrons (MLP), and non-negative matrix factorization (NMF) were evaluated through perceptual experiments involving CI recipients and normal hearing subjects. The results show that a MLP and DRNN perform well, providing minimal distortions and artifacts that are not perceived by CI users. The paper also highlights the benefits of the implementation of a MLP for real-time audio source separation to enhance music for CI users due to their reduced computation time. In addition, The study described in [25] proposes a speech separation framework for CI users using TasNet and RNN-EVD. TasNet, a non-causal multiple-input multiple-output (MIMO)-based method, is employed as the speech separation module. RNN-EVD, which combines RNNs with EVD, is utilized to preserve spatial cues. The framework aims to effectively separate speech and reduce ILD errors. The RNN-EVD network is trained using Δ ILD as the objective, and an additional SNR term is added to the loss function for convergence. The experimental results demonstrate the effectiveness of the proposed framework in preserving ILD cues for CI users in various hearing scenarios.

The long short term memory (LSTM), an enhanced version of the RNN, addresses limitations observed in RNNs under specific conditions [5, 70]. Unlike RNN, LSTM excels in preserving past information, making it suitable for tasks with long-term dependencies. Comprising LSTM units forming layers, each unit regulates information flow through input, output, and forget gates, allowing for prolonged retention of crucial information. The forward pass equations (4) illustrate this process [5]. The symbols L_i and L_j denote input and output, while A_f , A_i , and A_j represent activation vectors for forget, input, and output gates. V_c is the cell state vector, and σ for the sigmoid activation function and \odot for element-wise multiplication. This LSTM structure with weight matrices W and U and bias vector b is outlined by [71].

$$\begin{aligned} A_f &= \sigma(W_f * L_i + U_f * L_{j-1} + b_f), & A_i &= \sigma(W_i * L_i + U_i * L_{j-1} + b_i), \\ L_j &= A_j \odot \tanh(V_c), \\ A_j &= \sigma(W_0 * L_i + U_0 * L_{j-1} + b_j), \\ V_c &= A_f * V_{c-1} + A_i * \text{cell_state}(W_c * L_i + U_c * L_{j-1} + b_c). \end{aligned} \quad (4)$$

Recently, several schemes for CI and utilizing LSTM have been proposed in the literature. The study described by Lu. et al. in 2020 [64] introduces a speech training system designed for individuals with hearing impairments, such as those with CIs, as well as individuals with dysphonia, utilizing automated lip-reading recognition. The system combines CNN and RNN to compare mouth shapes and train speech skills. It includes a speech training database, automatic lip-reading using a hybrid neural network, matching lip shapes with sign language vocabulary, and drawing comparison data. The system enables hearing-impaired individuals to analyze and improve their vocal lip shapes independently. It also supports the use of medical devices for correct pronunciation. Experimental results demonstrate the system's effectiveness in correcting lip shape and enhancing speech ability. The proposed model utilizes ResNet50, MobileNet, and LSTM networks for accurate lip-reading recognition. Later on, the scientific paper published by Chu et al. in 2021 [72] proposes a causal DL framework for classifying phonemes in CIs to enhance speech intelligibility. The authors trained LSTM networks using features extracted at the time-frequency resolution of a CI processor. They compared CI-inspired features (log STFT power spectrum, log ACE power spectrum, and log-mel-filterbank) with traditional ASR features. The results showed that CI-inspired features outperformed traditional features, providing slightly higher levels of performance. The author claimed that, this study is the first to introduce a classification framework with the potential to categorize phonetic units in real-time in a CI, offering possibilities for improving speech recognition in reverberant environments for CI users. In 2023, Huang et al. proposed in [73], a DL-based sound coding strategy for CIs, called ElectrodeNet. By leveraging DNN, CNN, and LSTM, ElectrodeNet replaces conventional envelope detection in the ACE strategy. Objective evaluations using measures like STOI and NCM demonstrate strong correlations between ElectrodeNet and ACE. Additionally, subjective tests with normal-hearing listeners confirm the effectiveness of ElectrodeNet in sentence recognition for vocoded Mandarin speech. The study extends ElectrodeNet with ElectrodeNet-CS, incorporating channel selection (CS) through a modified DNN network. ElectrodeNet-CS produces N-of-M compatible electrode patterns and performs comparably or slightly better than ACE in terms of STOI and sentence recognition. This research showcases the feasibility and potential of deep learning in CI coding strategies, paving the way for future advancements in AI-powered CI systems. Similarly, the research presented by Jeyalakshmi et al. [65] focuses on predicting CI scores for children aged 5 to 10 using a reconfigured LSTM network as illustrated in Figure 9. The proposed architecture aims to enhance language development skills in children with auditory deprivation, this could be achieved by guiding CI programming through the analysis of cross-modal data obtained from previously programmed patients. The research utilizes visual cross-modal plasticity and visual evoked potential to discover patterns in the data that can predict outcomes for future patients. The proposed methodology involves the use of LSTM network and ESCSO to identify optimal weights. The results demonstrate the superiority of the ESCSO-based LSTM technique over other methods.

In Figure 9, "oz," "cz," "t5," and "t6" refer to specific electrode placements or positions on the scalp in the international 10-20 system for electroencephalography (EEG) or event-related potential (ERP) recordings. These positions represent specific areas on

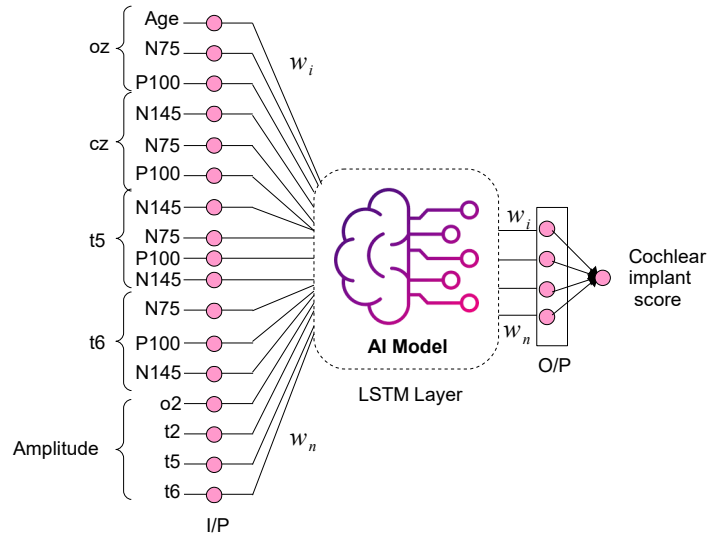

Figure 9: The design of the LSTM architecture suggested by Jeyalakshmi et al. [65].

the scalp where electrodes are attached to measure electrical activity in the brain. The amplitude represents the intensity or strength of the electrical signal detected at a particular point on the scalp, reflecting the neural activity in the corresponding brain region. The parameters "N75," "P100," and "N145" refer to specific components or peaks of ERPs obtained from EEG recordings. ERPs are electrical responses recorded from the brain in response to specific stimuli or events, and they reflect the neural processing associated with those stimuli. Besides, I/P represent inputs, O/P for output, and W represent Weights.

3.6. AE-based methods

An autoencoder (AE) is a type of neural network designed for unsupervised learning, tasked with encoding input data into a compressed representation and decoding it back to the original form. Examples include variational autoencoders (VAEs), which balance data compression with generative modeling, convolutional autoencoders (CAEs), which employ convolutional layers for efficient feature learning and reconstruction, and sparse AEs, which induce sparsity, promoting selectivity in feature representation, among others. The encoding equation typically involves a mapping function, such as $h = f(x)$, where h is the encoded representation and x is the input. The decoding equation is the reconstruction of the input, often expressed as $r = g(h)$, where r is the reconstructed output and g is the decoding function. AEs find applications in data compression, denoising, feature learning, and more. Recently, many research papers for CI have been proposed that are based on AE.

As a point of the case, the scientific paper [16] delves into the pivotal objective of enhancing speech perception for CI users in noisy conditions, recognizing the critical role of noise reduction (NR) in this pursuit. The proposed method, named DDAE-NR, has been proven effective in restoring clean speech. The study focuses on evaluating the DDAE-based NR using envelope-based vocoded speech, mimicking CI devices. The procedure of DDAE-based NR can be split into two main stages as shown in Figure 10: training and testing. During the training phase, a collection of pairs of noisy and clean speech signals is prepared. These signals are initially transformed into the frequency domain using an fast Fourier transform (FFT). The logarithmic amplitudes of the noisy and clean speech spectra are then used as inputs and outputs, respectively, for the DDAE model.

Key findings underscore the superior intelligibility of DDAE-based NR in vocoded speech compared to state-of-the-art (SOTA) conventional methods, indicating its potential implementation in CI speech processors. However, the study acknowledges the use of noise-vocoded speech simulation for evaluation and emphasizes the need for further validation with real CI recipients in clinical settings, addressing potential inconsistencies in the transition to actual CI devices.

A zero-delay deep autoencoder (DAE) is proposed in [21] for compressing and transmitting electrical stimulation patterns generated by CIs. The goal is to conserve battery power in wireless transmission while maintaining low latency, which is crucial for speech perception in CI users. The DAE architecture is optimized using Bayesian optimization and the STOI. The results show that the proposed DAE achieves equal or superior speech understanding compared to audio codecs, with reference vocoder STOI scores at 13.5 kbit/s. This approach offers a promising solution for efficient and real-time compression of CI stimulation patterns, addressing the constraints of low latency and battery power consumption. Moreover, The research in [60] focuses on achieving accurate segmentation of the vestibule in CT images, a crucial step for clinical diagnosis of congenital ear malformations and CIs. The challenges addressed include the small size and irregular shape of the vestibule, making segmentation difficult, and the limited availability of labelled samples due to high labour costs. To overcome these challenges, the proposed method introduces a vestibule segmentation network within a basic encoder-decoder framework. Key innovations include the incorporation of a residual channel attention (Res-CA) block for channel attention, a global context-aware pyramid feature extraction (GCPFE) module for global context information, an active contour with elastic loss (ACE-Loss) function for detailed boundary learning, and a deep supervision (DS) mechanism to enhance network robustness. The network architecture utilizes ResNet34 as the backbone with skip connections for multi-level feature fusion. Results showcases a high performance, and are supported by comprehensive comparisons,

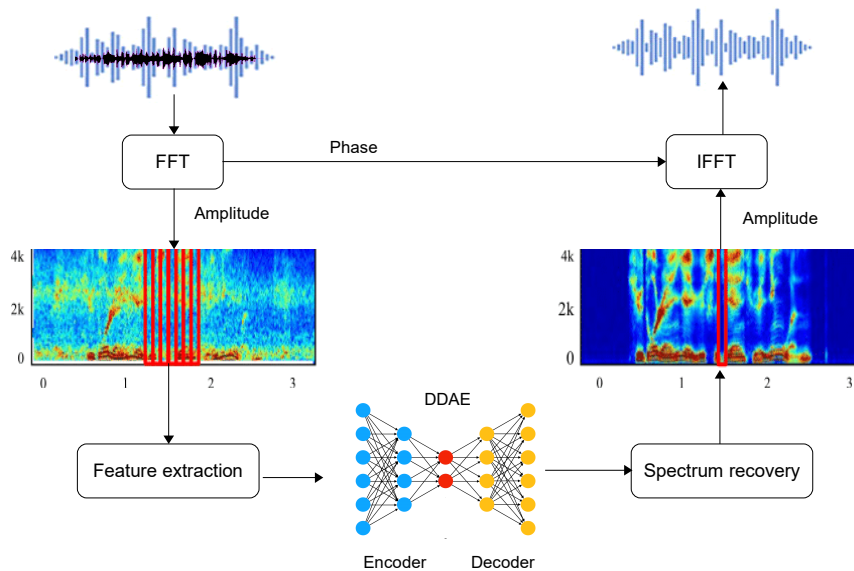

Figure 10: The configuration of a DDAE-based NR system for enhancing speech perception [16].

ablation studies, and visualized segmentation outcomes. The study also acknowledges limitations, such as reliance on professional annotations.

In addition, the study presented in [74] aims to enhance the accuracy and robustness of intra cochlear anatomy (ICA) segmentation, a vital component in preoperative decisions, insertion planning, and postoperative adjustments for CI procedures. The ICA includes structures such as scala tympani (ST), scala vestibuli (SV), and the active region (AR). The researchers employed two segmentation methods, active shape model (ASM) and DL based on 3D U-Net AE, and combined them to achieve improved accuracy and robustness. A two-level training strategy involved pretraining on clinical CTs using ASM and fine-tuning on specimens' CTs with ground truth. Results demonstrated that DL methods outperformed ASM in accuracy. While a trade-off between accuracy and robustness was observed, the combined DL and ASM approach showed improvements in both aspects. The study concludes that the proposed DL and ASM method effectively balances accuracy and robustness for ICA segmentation, highlighting the potential of DL-based methods, especially when integrated with ASM, to enhance CI procedures.

The proposed min-max similarity (MMS) methodology in [61] represents a groundbreaking approach to semi-supervised segmentation networks, particularly in the context of medical applications such as endoscopy surgical tool segmentation and CI surgery. MMS is introduced through dual-view training with contrastive learning, utilizing classifiers and projectors to create negative, positive, and negative pairs. The inclusion of pixel-wise contrastive loss ensures the consistency of unlabeled predictions. In the evaluation phase, MMS was tested on four public endoscopy surgical tool segmentation datasets and a manually annotated CI surgery dataset. The results demonstrate its superiority over state-of-the-art semi-supervised and fully supervised segmentation algorithms, both quantitatively and qualitatively. Notably, MMS exhibited successful recognition of unknown surgical tools, providing reliable predictions, and achieved real-time video segmentation with an impressive inference speed of about 40 frames per second. This signifies the potential of MMS as a highly effective and efficient tool in medical image segmentation, showcasing its applicability in real-world surgical scenarios.

Similarly, The primary aim of the study in [75] is to devise an automated method for the segmentation and measurement of the human cochlea in ultra-high-resolution (UHR) CT-images. The objective is to explore variations in cochlear size to enhance outcomes in cochlear surgery through personalized implant planning. Initially, the input scans undergo a two-step process using a detection module and a pixel-wise classification module for cochlea localization and segmentation, respectively using an AE as illustrated in Figure 11. The detection module reduces the search area for the classification module, improving algorithm speed and reducing false positives. Both modules are trained on image patches, allowing for a larger training set size by generating multiple examples from each scan. The segmented cochlear structure then proceeds to a final module that combines DL and thinning algorithms to extract patient-specific anatomical measurements. DL is employed in each step to leverage its ability to learn directly from input data, providing automatic results without the need for user-adjustable parameters during testing.

3.7. RL-based methods

Deep reinforcement learning (DRL) is a subfield of ML that enable agents to learn and make decisions in complex environments. It involves training an agent to interact with an environment, learn from the outcomes of its actions, and optimize its behavior over time [76]. In traditional RL, agents learn by trial and error, receiving feedback in the form of rewards or penalties for their actions. However, DRL incorporates DNN, make it capable of learning complex patterns and representations from raw data. This allows DRL agents to handle high-dimensional input spaces, such as images or sensor data, and make more sophisticated decisions. Figure 12 illustrate the priciple of RL.

The paper presented by radutoiu et al. [32] presents a novel method for accurately localizing regions of interests (ROIs) in the inner ear using DRL. The proposed method addresses the challenges of robust ROI extraction in full head CT scans, which

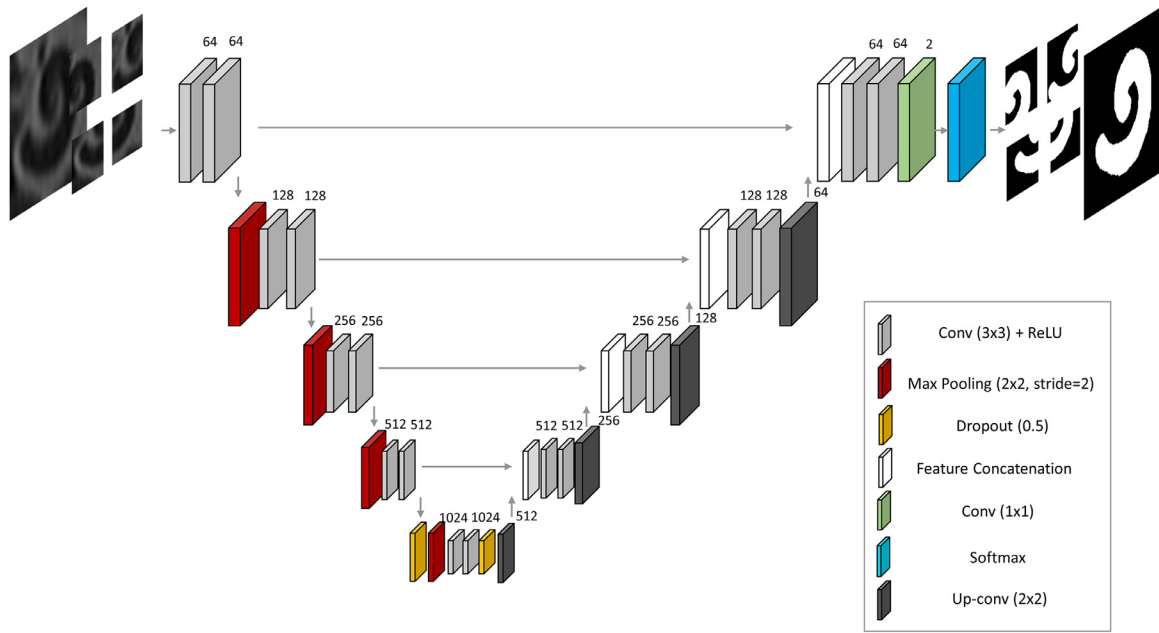

Figure 11: Encoder-decoder network used in the pixel-wise classification model [75].

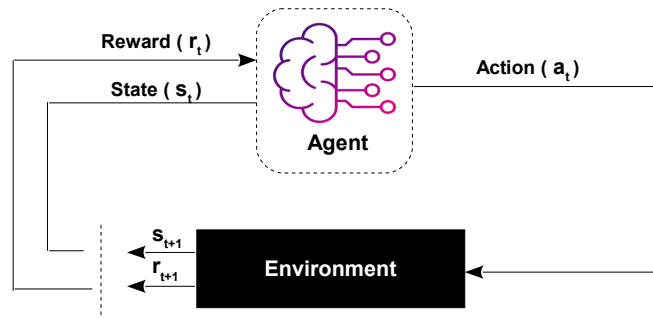

Figure 12: RL principle.

is crucial for CI surgery. The approach utilizes communicative multi-agent RL and landmarks specifically designed to extract orientation parameters. The method achieves an average estimated error of 1.07 mm for landmark localization. The extracted ROIs demonstrate an IoU of 0.84 and a dice similarity coefficient of 0.91, conducted over 140 full head CT scans, showing promising results for automatic ROI extraction in medical imaging. In addition, Lopez et al. presents in [77] a pipeline for characterizing facial and cochlear nerves in CT scans using DRL. Key landmarks around these nerves are located using a communicative multi-agent DRL model. The pipeline includes automated measurement of the cochlear nerve canal diameter, extraction and segmentation of the cochlear nerve cross-section, and path selection for the facial nerve characterization. The pipeline was developed and evaluated using 119 clinical CT images. The results show accurate characterizations of the nerves in the cochlear region, providing reliable measurements for computer-aided diagnosis and surgery planning. The proposed approach demonstrates the potential of DRL for landmark detection in challenging medical imaging tasks.

4. Applications of DL-based medical CI

This section explores the application of deep learning in the field of cochlear implants, encompassing tasks such as speech denoising and enhancement, segmentation for precise identification and analysis of cochlear structures, thresholding, imaging, localization of CI, and more. Figure 13 provides a comprehensive overview of AI-based applications for CIs and their associated benefits. Furthermore, Table 5 summarizes various applications based on AI techniques, highlighting their performance, and pros and cons.

4.1. Speech denoising and enhancement

The integration of ML, and DL has proven invaluable in the field of CIs. Researchers have harnessed these technologies to tackle numerous challenges and enhance speech perception for individuals with hearing impairments. The work [17, 78] employed DDAE approach to reduce unwanted background noise in speech signals. However, Lai et al. in [78] devised a NR system that employed a noise classifier and DDAE, specifically tailored for Mandarin-speaking CI recipients. The proposed schemes [22, 26, 79] aim to perform end-to-end speech denoising, with the goal of enhancing speech intelligibility in noisy environments. Gajecki et al. [22, 26]

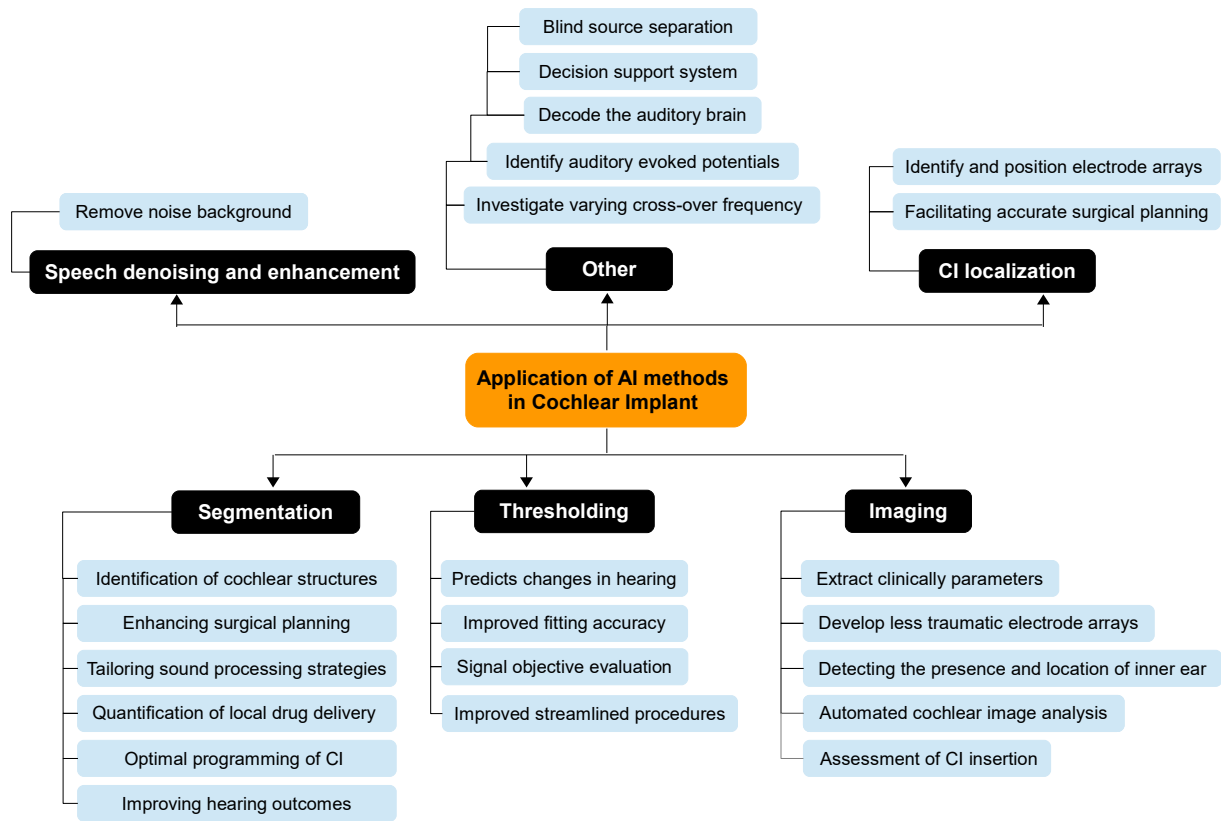

Figure 13: Taxonomy of AI-based applications for CIs and their benefits.

employed DNN to develop the Deep ACE method, while Healy et al. in [79] utilized DNN to separate speech from background noise. These examples underscore the broad spectrum of applications of AI, particularly DL techniques, in addressing challenges related to noise reduction and enhancing speech intelligibility in CIs applications.

Moreover, Kang et al. [28] used DL-based speech enhancement algorithms to optimize speech perception for CI recipients. Their approach achieved a balance between noise suppression and speech distortion by experimenting with different loss functions. Hu et al. [80] developed environment-specific noise suppression algorithms for CIs using ML techniques. They improved the processed sound by classifying and selecting envelope amplitudes based on the SNR in each channel. Banerjee et al. [81] employed online unsupervised algorithms to learn features from the speech of individuals with severe-to-profound hearing loss, aiming to enhance the audibility of speech through modified signal processing. Li et al. [82] developed an improved NR system for CIs using DL, specifically DDAE, and knowledge transfer technology. Their goal was to enhance speech intelligibility in noisy conditions. Fischer et al. [29] utilized DL-based virtual sensing of head-mounted microphones to improve speech signals in cocktail party scenarios for individuals with hearing loss, resulting in enhanced speech quality and intelligibility, particularly in noisy environments. These studies exemplify the versatility of AI and DL in addressing various challenges associated with CIs, including NR, speech enhancement, and improved speech perception. Furthermore, the paper by Chu et al. [23] explores the application of ML algorithms to mitigate the effects of reverberation and noise in CIs, to improve speech intelligibility for individuals with severe hearing loss.

4.2. Imaging

DL methods have revolutionized CI applications by leveraging imaging data for enhanced analysis and optimization. Hussain et al. [87] employed image analysis tools, such as the oticon medical nautilus software, to automatically detect landmarks and extract clinically relevant parameters from cochlear CT images. This approach provides valuable insights into cochlear morphology, facilitating the development of less traumatic electrode arrays for cochlear implantation. Zhang et al. [57] focused on automatically detecting the presence and location of inner ears in head CT images, aiming to assist in image-guided CI programming for patients with profound hearing loss. Regodic et al. [88] introduced an algorithm that utilizes a CNN for automatic fiducial marker detection and localization in CT images, enhancing registration accuracy, reducing human errors, and shortening intervention time in computer-assisted surgeries. Margeta et al. [83] presented Nautilus, a web-based research platform that employs AI and image processing techniques for automated cochlear image analysis. This platform enables accurate delineation of cochlear structures, detection of electrode locations, and personalized pre- and post-operative metrics, facilitating clinical exploration in cochlear implantation studies. Li et al. [89] proposed the integration of DL techniques into a clinical μ CT system to optimize imaging performance, improve reconstruction accuracy, and enhance diagnostic capabilities in temporal bone imaging and other clinical

¹⁵<https://github.com/APGDHZ/DeepACE2.0>

¹⁶nautilus_info@oticonmedical.com available upon reasonable request

Table 5

Summary of the performance and limitations of specific DL applications dedicated to CIs. In cases where multiple tests are conducted, only the best performance is reported.

Ref.	Year	DLM	Description	BP (%)	Limitations	PLA
[82]	2021	NC and DDAE_T	The DL model comprises Siren noise at 6dB, a classifier, and the DDAE. The transfer learning (TL) is incorporated to help reduce the number of parameters in the model.	PESQ= 3.037 STOI= 0.843	The performance of the DL model can be degraded when there is a mismatch between the training and testing data.	No
[22]	2023	DeepACE	Takes the raw audio signal as input and generates a denoised electrodiagram, which represents the electrical stimulation patterns applied to the electrodes over time.	STOI =0.807	Heavy data reliance impedes performance with insufficient or biased data, posing generalization challenges. Computational complexity, interpretability issues, and vulnerability are concerns.	Yes ¹⁵
[29]	2021	U-Net	The proposed approach involves using deep virtual sensing to estimate microphone signals, improving speech quality in cocktail party scenarios for hearing aid and CI users.	PESQ=2, STOI=0.53, SI- SDR=-28.91dB	Challenges include long delay impracticality for hearing aids, binaural cues omission, insufficient network optimization, and exploring robustness in high-reverberation environments.	No
[83]	2022	CNN	A web-based research platform called Nautilus, which utilizes DL techniques for automated image processing in cochlear implantation-related studies.	DCS= 80 ±3%, ASD= 0.19 ±0.04mm	Dependence on large amounts of annotated training data poses a challenge. Ensuring generalizability across various imaging conditions and populations is crucial.	Yes ¹⁶
[60]	2023	AE+Res-CA	Is a vestibule segmentation network for CT images. It is based on the basic encoder-decoder framework and incorporates Res-CA Block, GCPFE and ACE-Loss Function	DCS=94.77 ±2.45%, ASD=0.06 mm	Limited training data, small object handling, generalization capability, and computational resource constraints are areas of concern.	No
[84]	2019	cGAN	Is a DL-based method for accurately localizing CI electrode contacts in CT images, facilitating customization of CI settings.	success rate of lo- calization =96.7%	coarse resolution, metal artifacts, difficulty isolating contacts from cortical bones, site-dependent image quality, and variability among electrode array manufacturers.	No
[32]	2022	DRL	Is a novel method for accurately extracting ROIs in the inner ear from CT scans. The approach achieves high precision and demonstrates promising results for surgical planning in cochlear implantation.	IoU=0.84 DSC=0.91	Small dataset, image quality variability, and computational requirements not specified.	No
[75]	2020	U-Net	Is a multi-scale DL framework for automatic segmentation and measurement of the human cochlea in clinical ultra-high-resolution CT images, with potential applications in personalized CI surgery.	DSC=0.90 ±0.03 BF=0.95±0.03	The work include a small dataset, potential variability in image quality, lack of external validation, and limited assessment of clinical utility and computational requirements.	No
[85]	2023	UNETR	Explores the feasibility of using a DL method based on the UNETR model for automatic segmentation of the cochlea in temporal bone CT images.	DSC=0.92	The small dataset used, the variability in image quality, and the absence of specifications regarding computational requirements.	No
[86]	2019	3D U-NET	Is a two-level training approach using a DL method to accurately segment the intra-cochlear anatomy in head CT scans. The method combines an active shape model-based method and a 3D U-Net model	DSC=0.87	Limited dataset, variable image quality, lack of external validation, limited assessment of clinical utility, and no specifications on computational requirements.	No
[34]	2023	AlexNet	The study assesses repeatability, thresholds, and tonotopic patterns using a DL-based algorithm, providing insights into inner ear function and potential clinical applications.	Acc=83.8%	Potential dependence on the quality of the input data, limited generalizability to different patient populations or implant systems, and the need for further external validation and comparison with expert visual inspection.	No

Abbreviations: Deep learning model (DLM); Best performance (BP); Project link availability (PLA).

applications. Wang et al. [68] addressed the reduction of metal artifacts in post-operative CI CT imaging using a 3D GAN, enabling better analysis of electrode positions and assessment of CI insertion. These advancements highlight the significant role of DL, ML, and AI in leveraging imaging data for improved CI analysis, design, and surgical procedures.

In addition to the previous advancements, DL and AI have been applied to various aspects of CI applications using imaging data. Chen et al. [60] utilize AI for accurate vestibule segmentation in CT images, which plays a crucial role in the clinical diagnosis of congenital ear malformations and CI procedures. Kugler et al. [90] employ AI techniques to accurately estimate instrument pose from X-ray images in temporal bone surgery, enabling high-precision navigation and facilitating minimally invasive procedures. Waldeck et al. [91] develop an ultra-fast algorithm that utilizes automated cochlear image registration to detect misalignment in CIs, significantly reducing the time required for diagnosis compared to traditional multiplanar reconstruction analysis. Finally, Chen et al. [92] focus on creating a three-dimensional finite element model of the brain based on magnetic resonance imaging (MRI) data to analyze and optimize the current flow path induced by CIs. This application of AI contributes to the improvement of implant design in the future. These innovative approaches demonstrate the diverse applications of DL, ML, and AI in CI research, ranging from scene understanding to precise segmentation, instrument pose estimation, misalignment detection, and implant design optimization.

4.3. Segmentation

DL, ML, and AI have revolutionized CI segmentation, enabling precise identification and analysis of cochlear structures in various imaging modalities. Li et al. [85] applied a UNETR model to automatically segment cochlear structures in temporal bone CT images, enhancing surgical planning and cochlear implantation outcomes. Reda et al. [93] developed an automatic segmentation method for intra-cochlear anatomy in post-implantation CT scans, facilitating the customization of sound processing strategies for individual CI recipients. Moudgalya et al. [94] employed a modified V-Net CNN to segment cochlear compartments in μ CT images,

enabling precise quantification of local drug delivery for potential treatment of sensorineural hearing loss. Wang et al. [95] focused on metal artifact reduction and intra-cochlear anatomy segmentation in CT images using a multi-resolution multi-task deep network, benefiting CI recipients. Heutink et al. [75] developed a DL framework for the automatic segmentation and analysis of cochlear structures in ultra-high-resolution CT images, providing accurate measurements for personalized implant planning in cochlear surgery. Zhang et al. [86] utilized a 3D U-Net DL method to achieve accurate segmentation of intra-cochlear anatomy in head CT images, facilitating optimal programming of CIs and improving hearing outcomes. These studies highlight the significant impact of DL, ML, and AI in advancing CI segmentation, ultimately leading to improved patient care and treatment outcomes.

4.4. Thresholding

DL, ML, and AI have been instrumental in the field of CIs, particularly in thresholding applications. Kuczapski et al. [96] developed a software tool that utilizes AI to estimate and monitor the effective stimulation threshold (EST) levels in CI recipients. By leveraging patient data, audiograms, and fitting settings, this tool aids in the fitting process and predicts changes in hearing levels, enhancing personalized care. Botros et al. [97] introduced AutoNRT, an automated system that combines ML and pattern recognition to measure electrically evoked compound action potential (ECAP) thresholds with the Nucleus Freedom CI. This objective fitting system streamlines clinical procedures and ensures precise and efficient threshold measurements. Furthermore, Schuerch et al. [34] utilized a DL-based algorithm to objectively evaluate and analyze ECochG signals. This algorithm enables the assessment of ECochG measurement repeatability, comparison with audiometric thresholds, and identification of signal patterns and tonotopic behavior in CI recipients. Through the integration of DL, machine ML, and AI, these studies have significantly advanced thresholding techniques in CI applications, leading to improved fitting accuracy, streamlined procedures, and objective evaluation of signal responses.

4.5. Localization of CI

DL methods have been instrumental in CI localization applications, providing accurate and automated solutions. Chi et al. [84] proposed a DL-based method for precise localization of electrode contacts in CT images. Their approach utilized cGANs to generate likelihood maps, which were then processed to estimate the exact location of each contact. Radutoiu et al. [32] focused on the automatic extraction of ROIs in full head CT scans of the inner ear. By leveraging AI, they achieved high precision in ROI localization, facilitating accurate surgical planning for insertion. Noble et al. [98] and Zhao et al. [99, 100], developed AI-based systems to automatically identify and position electrode arrays in CT images. These technologies enable large-scale analyses of the relationship between electrode placement and hearing outcomes, leading to potential advancements in implant design and surgical techniques. Heutink et al. [75] employed DL for the automatic segmentation and localization of the cochlea in ultra-high-resolution CT images. This approach allows for precise measurements that can be used in personalized planning, reducing the risk of intracochlear trauma and optimizing surgical outcomes. These studies showcase the significant contributions of DL and AI in localization applications, enabling accurate and efficient identification, positioning, and analysis of electrode arrays and facilitating improved surgical planning and outcomes.

4.6. Other

DL techniques have been employed in various CI applications, showcasing their potential to enhance hearing outcomes and improve device performance. Bermejo et al. [101] introduced a decision support system using a novel probabilistic graphical model to optimize CI parameters based on audiological tests and the current device status, aiming to optimize the user's hearing ability. Castaneda et al. [102] focused on the use of blind source separation (BSS) and independent component analysis (ICA) to identify auditory evoked potentials (AEPs) and isolate artifacts in children with CIs, enabling improved assessment of auditory function. Incerti et al. [103] investigated the impact of varying cross-over frequency settings for EAS on binaural speech perception, localization, and functional performance in adults with CIs and residual hearing, providing valuable insights for personalized device programming. Katthi et al. [104] developed a DL framework based on canonical correlation analysis (CCA) to decode the auditory brain, establishing a strong correlation between audio input and brain activity measured through EEG recordings. This research has implications for decoding human auditory attention and improving CIs by leveraging the power of DL.

5. Open issues and future directions

While significant strides have been achieved in integrating AI into CIs, numerous research lacunae persist, offering avenues for further advancements in the field. Here are several potential realms warranting exploration in future studies:

Real-time signal processing and personalized design: Investigating real-time adaptive signal processing methods employing AI algorithms has the potential to enhance sound processing for CI recipients, yielding enhanced speech intelligibility outcomes. Enhancements in adaptability to dynamic acoustic environments and real-time optimization of stimulation parameters have the capacity to substantially enhance CI performance. The authors have observed a gap in the study and implementation of AI models tailored for CI on real-time platforms like field programmable gate arrays (FPGAs). Further research in this burgeoning area holds promise for adapting a variety of existing AI models to enhance real-time capabilities.

Besides, tailoring CIs to meet the unique needs of individual users poses a significant challenge. Investigating AI-driven methodologies leveraging personal data to personalize device configurations based on factors like physiological, auditory, and neural feedback during mobility can enhance both individual outcomes and overall satisfaction.

Predicting the long-term effects: Gaining insight into the enduring CIs is vital for enhancing patient selection, counseling, and device advancement. Utilizing AI methods to shift through extensive datasets can pinpoint the predictive elements influencing sustained success. These factors may encompass pre-implantation attributes, surgical approaches, and auditory rehabilitation. Constructing predictive models using AI algorithms can furnish valuable perspectives on long-term consequences, thereby informing clinical judgments.

Incorporating multiple sensory and modalities: CIs traditionally prioritize the reinstatement of auditory experiences. Yet, enriching the perception and comprehension of sound can be achieved by integrating additional sensory dimensions like vision and touch, resulting in a multi-modal approach. Investigating AI-driven techniques that amalgamate inputs from various senses to enhance speech recognition, spatial sound perception, and overall auditory understanding presents a promising direction for future exploration. Besides, CIs in both ears, when paired with AI algorithms, can enhance speech comprehension. By analyzing sound patterns from both implants, AI adjusts settings to optimize signal processing, improving overall accuracy and clarity of speech perception for users with bilateral implants, and enhancing their auditory experience and communication abilities, as investigated in [105]. However, extensive research possibilities are required to tailor solutions with CI hardware capabilities, by taking into account computation cost, and AI model complexity.

Empowering AI-based CI using DTL: Deep transfer learning (DTL) is a highly efficient DL technique enabling the transfer of knowledge from pre-trained models, trained on millions of speech corpora and/or images, to train smaller models with limited data availability. This approach offers significant advantages in producing lightweight AI models suitable for devices with limited computational resources, such as CIs. Only a limited number of studies have explored the impact of DTL on CI, as demonstrated in [82], which has received relatively little attention from researchers. We anticipate further exploration of this promising technique, particularly through the utilization of various DTL sub-techniques, such as domain adaptation, transductive methods like cross-lingual transfer, cross-corpus transfer, zero-shot learning, fine-tuning, among others [2].

Ensuring data privacy through FL: Federated learning (FL) facilitates collaborative model training across decentralized devices by aggregating local updates rather than centralizing data. This preserves user privacy and enhances model performance, particularly beneficial in healthcare applications [106]. Gathering comprehensive datasets is challenging due to rare anomaly cases and privacy concerns. FL addresses this by training models on distributed, encrypted data from multiple sources, ensuring privacy while maintaining efficacy. Researchers have yet to fully explore FL-based model building for CI, neglecting the potential to construct efficient AI models capable of accommodating diverse classes. Further investigation into this promising technique is warranted, with potential for significant advancements in model robustness and versatility. Moreover, this approach could lead to the development of a pretrained model utilizing FL, which could be seamlessly integrated with DTL.

Transformers-based CI techniques: Transformer-based techniques, such as connectionist temporal classification (CTC), bidirectional encoder representations from transformer (BERT), and others, proved in the literature that have the potential to greatly enhance the functioning of ASR [107, 108]. By leveraging the self-attention mechanism, transformers can improve speech intelligibility by effectively suppressing background noise and modeling long-range dependencies. They can also aid in acoustic scene analysis, separating and prioritizing important auditory information in complex environments. Transformers can build language models that enhance ASR systems, improving speech comprehension for users. Additionally, transformers enable personalized sound processing by adapting stimulation patterns and processing parameters based on user-specific preferences. They facilitate multi-modal integration, combining audio and visual inputs to enhance speech recognition and sound localization. Furthermore, transformers support long-term learning and adaptation, continually optimizing CI performance over time. These advancements offer promising prospects for improving auditory experiences and overall quality of life for CI users.

Exploring chat-bots-based CI capabilities: Chat-bot techniques offer several opportunities to enhance the functioning of CIs. They can provide real-time support, troubleshooting, and personalized rehabilitation programs for users, empowering them to address common issues and improve their auditory skills. Chat-bots enable remote monitoring, allowing users to share data and receive adjustments to their device settings without in-person appointments. They also offer emotional and psychological support, fostering a sense of community and well-being. Chat-bots contribute to data collection for research and development, aiding in the improvement of CI technology and rehabilitation protocols. Additionally, chat-bots employ ML to continuously learn from user interactions, improving their responses and understanding over time. These techniques have the potential to enhance the overall user experience, outcomes, and accessibility of CI services.

6. Conclusion

This review has provided a comprehensive overview of the advancements in AI algorithms for CIs applications and their impact on ASR and speech enhancement. The integration of AI methods has brought cutting-edge strategies to address the limitations and challenges faced by traditional signal processing techniques in the context of CIs. Moreover, the application of AI in CI has led to the emergence of new datasets and evaluation metrics, offering alternative methods for validating proposed schemes without the need for human surgical intervention and traditional tests. The review highlighted the role of ASR in optimizing speech perception and understanding for CI users, contributing to the improvement of their quality of life. ASR not only enhances basic speech recognition but also aids in the recognition of environmental sounds, enabling a more immersive auditory experience. Furthermore, ASR finds applications in authentication systems, event recognition, source separation, and speaker recognition, extending its reach beyond communication. Various AI algorithms, belong to ML and DL, have been explored in the context of CIs, demonstrating promising

results in speech synthesis and noise reduction. These algorithms have shown the potential to overcome challenges associated with multiple sources of speech, environmental noise, and other complex scenarios. The review has summarized and commented on the best results obtained, providing valuable insights into the capabilities of AI algorithms in this biomedical field. Moving forward, the review suggests future directions to bridge existing research gaps in the domain of AI algorithms for CIs. It emphasizes the need for high-quality data inputs, algorithm transparency, and collaboration between researchers, clinicians, and industry experts. Addressing these aspects will facilitate the development of more accurate and efficient AI algorithms for CI, ultimately benefiting individuals with hearing impairments. The integration of advanced AI algorithms has the potential to revolutionize the field of CIs, providing individuals with hearing impairments to better communicate and engage with the world around them. Continued research and development in this area hold great promise for the future of CI technology.

Acknowledgement

The second author acknowledges that the study was partially funded by the Algerian Ministry of Higher Education and Scientific Research (Grant No. PRFU–A25N01UN260120230001).

References

- [1] M. B. Er, E. Isik, I. Isik, Parkinson's detection based on combined cnn and lstm using enhanced speech signals with variational mode decomposition, *Biomedical Signal Processing and Control* 70 (2021) 103006.
- [2] H. Kheddar, Y. Himeur, S. Al-Maadeed, A. Amira, F. Bensaali, Deep transfer learning for automatic speech recognition: Towards better generalization, *Knowledge-Based Systems* 277 (2023) 110851. doi:10.1016/j.knosys.2023.110851.
- [3] S. Hu, X. Shang, Z. Qin, M. Li, Q. Wang, C. Wang, Adversarial examples for automatic speech recognition: Attacks and countermeasures, *IEEE Communications Magazine* 57 (10) (2019) 120–126.
- [4] H. Kheddar, D. Megias, High capacity speech steganography for the g723. 1 coder based on quantised line spectral pairs interpolation and cnn auto-encoding, *Applied Intelligence* 52 (8) (2022) 9441–9459.
- [5] H. Kheddar, M. Hemis, Y. Himeur, D. Megias, A. Amira, Deep learning for steganalysis of diverse data types: A review of methods, taxonomy, challenges and future directions, *Neurocomputing* (2024) 127528doi:https://doi.org/10.1016/j.neucom.2024.127528.
- [6] H. Kheddar, D. Megias, M. Bouzid, Fourier magnitude-based steganography for hiding 2.4 kbps melp secret speech, in: 2018 International Conference on Applied Smart Systems (ICASS), IEEE, 2018, pp. 1–5.
- [7] N. Singh, A. Agrawal, R. Khan, Voice biometric: A technology for voice based authentication, *Advanced Science, Engineering and Medicine* 10 (7-8) (2018) 754–759.
- [8] T.-E. Chen, S.-I. Yang, L.-T. Ho, K.-H. Tsai, Y.-H. Chen, Y.-F. Chang, Y.-H. Lai, S.-S. Wang, Y. Tsao, C.-C. Wu, S1 and s2 heart sound recognition using deep neural networks, *IEEE Transactions on Biomedical Engineering* 64 (2) (2016) 372–380.
- [9] M. G. Crowson, V. Lin, J. M. Chen, T. C. Chan, Machine learning and cochlear implantation—a structured review of opportunities and challenges, *Otology & Neurotology* 41 (1) (2020) e36–e45.
- [10] A. Manero, K. E. Crawford, H. Prock-Gibbs, N. Shah, D. Gandhi, M. J. Coathup, Improving disease prevention, diagnosis, and treatment using novel bionic technologies, *Bioengineering & Translational Medicine* 8 (1) (2023) e10359.
- [11] B. S. Wilson, D. L. Tucci, D. A. Moses, E. F. Chang, N. M. Young, F.-G. Zeng, N. A. Lesica, A. M. Bur, H. Kavookjian, C. Mussatto, et al., Harnessing the power of artificial intelligence in otolaryngology and the communication sciences, *Journal of the Association for Research in Otolaryngology* 23 (3) (2022) 319–349.
- [12] K. L. D'Onofrio, F.-G. Zeng, Tele-audiology: Current state and future directions, *Frontiers in Digital Health* 3 (2022) 788103.
- [13] F. Henry, M. Glavin, E. Jones, Noise reduction in cochlear implant signal processing: A review and recent developments, *IEEE reviews in biomedical engineering* (2021).
- [14] O. Macherey, R. P. Carlyon, Cochlear implants, *Current Biology* 24 (18) (2014) R878–R884.
- [15] N. Y.-H. Wang, H.-L. S. Wang, T.-W. Wang, S.-W. Fu, X. Lu, H.-M. Wang, Y. Tsao, Improving the intelligibility of speech for simulated electric and acoustic stimulation using fully convolutional neural networks, *IEEE Transactions on Neural Systems and Rehabilitation Engineering* 29 (2020) 184–195.
- [16] Y.-H. Lai, F. Chen, S.-S. Wang, X. Lu, Y. Tsao, C.-H. Lee, A deep denoising autoencoder approach to improving the intelligibility of vocoded speech in cochlear implant simulation, *IEEE Transactions on Biomedical Engineering* 64 (7) (2016) 1568–1578.
- [17] S.-S. Wang, Y. Tsao, H.-L. S. Wang, Y.-H. Lai, L. P.-H. Li, A deep learning based noise reduction approach to improve speech intelligibility for cochlear implant recipients in the presence of competing speech noise, in: 2017 Asia-Pacific Signal and Information Processing Association Annual Summit and Conference (APSIPA ASC), IEEE, 2017, pp. 808–812.
- [18] L. L. Wong, S. D. Soli, S. Liu, N. Han, M.-W. Huang, Development of the mandarin hearing in noise test (mhint), *Ear and hearing* 28 (2) (2007) 70S–74S.
- [19] T. Arias-Vergara, P. Klumpp, J. C. Vasquez-Correa, E. Nöth, J. R. Orozco-Arroyave, M. Schuster, Multi-channel spectrograms for speech processing applications using deep learning methods, *Pattern Analysis and Applications* 24 (2021) 423–431.
- [20] T. Arias-Vergara, J. C. Vasquez-Correa, S. Gollwitzer, J. R. Orozco-Arroyave, M. Schuster, E. Nöth, Multi-channel convolutional neural networks for automatic detection of speech deficits in cochlear implant users, in: *Progress in Pattern Recognition, Image Analysis, Computer Vision, and Applications: 24th Iberoamerican Congress, CIARP 2019, Havana, Cuba, October 28-31, 2019, Proceedings 24*, Springer, 2019, pp. 679–687.
- [21] R. Hinrichs, F. Ortman, J. Ostermann, Vector-quantized zero-delay deep autoencoders for the compression of electrical stimulation patterns of cochlear implants using stoi, in: 2022 IEEE-EMBS Conference on Biomedical Engineering and Sciences (IECBES), IEEE, 2022, pp. 165–170.
- [22] T. Gajeci, Y. Zhang, W. Nogueira, A deep denoising sound coding strategy for cochlear implants, *IEEE Transactions on Biomedical Engineering* (2023).
- [23] K. Chu, C. Throckmorton, L. Collins, B. Mainsah, Using machine learning to mitigate the effects of reverberation and noise in cochlear implants, in: *Proceedings of Meetings on Acoustics, Vol. 33*, AIP Publishing, 2018.
- [24] R. Grimm, M. Pettinato, S. Gillis, W. Daelemans, Simulating speech processing with cochlear implants: How does channel interaction affect learning in neural networks?, *Plos one* 14 (2) (2019) e0212134.
- [25] Z. Feng, Y. Tsao, F. Chen, Preservation of interaural level difference cue in a deep learning-based speech separation system for bilateral and bimodal cochlear implants users, in: 2022 International Workshop on Acoustic Signal Enhancement (IWAENC), IEEE, 2022, pp. 1–5.
- [26] T. Gajeci, W. Nogueira, An end-to-end deep learning speech coding and denoising strategy for cochlear implants, in: *ICASSP 2022-2022 IEEE International Conference on Acoustics, Speech and Signal Processing (ICASSP)*, IEEE, 2022, pp. 3109–3113.
- [27] I. Hochmair-Desoyer, E. Schulz, L. Moser, M. Schmidt, The hsm sentence test as a tool for evaluating the speech understanding in noise of cochlear implant users., *The American journal of otology* 18 (6 Suppl) (1997) S83–S83.

- [28] Y. Kang, N. Zheng, Q. Meng, Deep learning-based speech enhancement with a loss trading off the speech distortion and the noise residue for cochlear implants, *Frontiers in Medicine* 8 (2021) 740123.
- [29] T. Fischer, M. Caversaccio, W. Wimmer, Speech signal enhancement in cocktail party scenarios by deep learning based virtual sensing of head-mounted microphones, *Hearing research* 408 (2021) 108294.
- [30] T. Fischer, M. Caversaccio, W. Wimmer, Multichannel acoustic source and image dataset for the cocktail party effect in hearing aid and implant users, *Scientific data* 7 (1) (2020) 440.
- [31] S. Tahmasebi, T. Gajeci, W. Nogueira, Design and evaluation of a real-time audio source separation algorithm to remix music for cochlear implant users, *Frontiers in Neuroscience* 14 (2020) 434.
- [32] A.-T. Radutoiu, F. Patou, J. Margeta, R. R. Paulsen, P. López Diez, Accurate localization of inner ear regions of interests using deep reinforcement learning, in: *International Workshop on Machine Learning in Medical Imaging*, Springer, 2022, pp. 416–424.
- [33] K. Schuerch, W. Wimmer, A. Dalbert, C. Rummel, M. Caversaccio, G. Mantokoudis, S. Weder, Objectification of intracochlear electrocochleography using machine learning, *Frontiers in neurology* 13 (2022) 943816.
- [34] K. Schuerch, W. Wimmer, C. Rummel, M. D. Caversaccio, S. Weder, Objective evaluation of intracochlear electrocochleography: repeatability, thresholds, and tonotopic patterns, *Frontiers in neurology* 14 (2023).
- [35] K. Schuerch, W. Wimmer, A. Dalbert, C. Rummel, M. Caversaccio, G. Mantokoudis, T. Gawliczek, S. Weder, An intracochlear electrocochleography dataset from raw data to objective analysis using deep learning, *Scientific data* 10 (1) (2023) 157.
- [36] Y. Habchi, Y. Himeur, H. Kheddar, A. Boukabou, S. Atalla, A. Chouchane, A. Ouamane, W. Mansoor, Ai in thyroid cancer diagnosis: Techniques, trends, and future directions, *Systems* 11 (10) (2023) 519.
- [37] C. H. Taal, R. C. Hendriks, R. Heusdens, J. Jensen, A short-time objective intelligibility measure for time-frequency weighted noisy speech, in: *2010 IEEE international conference on acoustics, speech and signal processing*, IEEE, 2010, pp. 4214–4217.
- [38] P. J. Govaerts, B. Vaerenberg, G. De Ceulaer, K. Daemers, C. De Beukelaer, K. Schauwers, Development of a software tool using deterministic logic for the optimization of cochlear implant processor programming, *Otology & Neurotology* 31 (6) (2010) 908–918.
- [39] B. Vaerenberg, P. J. Govaerts, G. De Ceulaer, K. Daemers, K. Schauwers, Experiences of the use of fox, an intelligent agent, for programming cochlear implant sound processors in new users, *International Journal of Audiology* 50 (1) (2011) 50–58.
- [40] M. Meeuws, D. Pascoal, I. Bermejo, M. Artaso, G. De Ceulaer, P. J. Govaerts, Computer-assisted ci fitting: Is the learning capacity of the intelligent agent fox beneficial for speech understanding?, *Cochlear Implants International* 18 (4) (2017) 198–206.
- [41] J. Wathour, P. J. Govaerts, N. Deggouj, From manual to artificial intelligence fitting: two cochlear implant case studies, *Cochlear implants international* 21 (5) (2020) 299–305.
- [42] S. B. Waltzman, D. C. Kelsall, The use of artificial intelligence to program cochlear implants, *Otology & Neurotology* 41 (4) (2020) 452–457.
- [43] J. Wathour, P. J. Govaerts, L. Derue, S. Vanderbemden, H. Huaux, E. Lacroix, N. Deggouj, Prospective comparison between manual and computer-assisted (fox) cochlear implant fitting in newly implanted patients (2023).
- [44] T. Eichler, W. Rötz, C. Kayser, F. Bröhl, M. Römer, A. H. Witteborg, F. Kummert, T. Sandmeier, C. Schulte, P. Stolz, et al., Algorithm-based hearing and speech therapy rehabilitation after cochlear implantation, *Brain Sciences* 12 (5) (2022) 580.
- [45] J. Torresen, A. H. Iversen, R. Greisiger, Data from past patients used to streamline adjustment of levels for cochlear implant for new patients, in: *2016 IEEE Symposium Series on Computational Intelligence (SSCI)*, IEEE, 2016, pp. 1–7.
- [46] F. Henry, A. Parsi, M. Glavin, E. Jones, Experimental investigation of acoustic features to optimize intelligibility in cochlear implants, *Sensors* 23 (17) (2023) 7553.
- [47] C. Pavelchek, A. P. Michelson, A. Walia, A. Ortmann, J. Herzog, C. A. Buchman, M. A. Shew, Imputation of missing values for cochlear implant candidate audiometric data and potential applications, *Plos one* 18 (2) (2023) e0281337.
- [48] C. Xu, F.-Y. Cheng, S. Medina, E. Eng, R. Gifford, S. Smith, Objective discrimination of bimodal speech using frequency following responses, *Hearing research* 437 (2023) 108853.
- [49] H. Kheddar, M. Bouzid, D. Megías, Pitch and fourier magnitude based steganography for hiding 2.4 kbps melp bitstream, *IET Signal Processing* 13 (3) (2019) 396–407.
- [50] M. G. Crowson, P. Dixon, R. Mahmood, J. W. Lee, D. Shipp, T. Le, V. Lin, J. Chen, T. C. Chan, Predicting postoperative cochlear implant performance using supervised machine learning, *Otology & Neurotology* 41 (8) (2020) e1013–e1023.
- [51] P. Mikulskis, A. Hook, A. A. Dundas, D. Irvine, O. Sanni, D. Anderson, R. Langer, M. R. Alexander, P. Williams, D. A. Winkler, Prediction of broad-spectrum pathogen attachment to coating materials for biomedical devices, *ACS applied materials & interfaces* 10 (1) (2018) 139–149.
- [52] Y. A. Alohal, M. S. Fayed, Y. Abdelsamad, F. Almuawas, A. Alahmadi, T. Mesallam, A. Hagr, Machine learning and cochlear implantation: Predicting the post-operative electrode impedances, *Electronics* 12 (12) (2023) 2720.
- [53] R. Islam, E. Abdel-Raheem, M. Tarique, A novel pathological voice identification technique through simulated cochlear implant processing systems, *Applied Sciences* 12 (5) (2022) 2398.
- [54] J. de Nobel, A. V. Kononova, J. J. Briaire, J. H. Frijns, T. H. Bäck, Optimizing stimulus energy for cochlear implants with a machine learning model of the auditory nerve, *Hearing Research* 432 (2023) 108741.
- [55] T. Bäck, H.-P. Schwefel, An overview of evolutionary algorithms for parameter optimization, *Evolutionary computation* 1 (1) (1993) 1–23.
- [56] D. Baby, A. Van Den Broucke, S. Verhulst, A convolutional neural-network model of human cochlear mechanics and filter tuning for real-time applications, *Nature machine intelligence* 3 (2) (2021) 134–143.
- [57] D. Zhang, J. H. Noble, B. M. Dawant, Automatic detection of the inner ears in head ct images using deep convolutional neural networks, in: *Medical Imaging 2018: Image Processing*, Vol. 10574, SPIE, 2018, pp. 565–572.
- [58] W. Li, T. Gueuret, B. Lin, Poster: Slidcnn: Deep learning for auditory spatial scenes with limited annotated data, in: *2022 IEEE/ACM 7th Symposium on Edge Computing* (SEC), IEEE, 2022, pp. 316–317.
- [59] M.-H. Laves, S. Ihler, L. A. Kahrs, T. Ortmaier, Deep-learning-based 2.5 d flow field estimation for maximum intensity projections of 4d optical coherence tomography, in: *Medical Imaging 2019: Image-Guided Procedures, Robotic Interventions, and Modeling*, Vol. 10951, SPIE, 2019, pp. 189–195.
- [60] M. Chen, L. Zhuo, Z. Zhu, H. Yin, X. Li, Z. Wang, Deeply supervised vestibule segmentation network for ct images with global context-aware pyramid feature extraction, *IET Image Processing* 17 (4) (2023) 1267–1279.
- [61] A. Lou, K. Tawfik, X. Yao, Z. Liu, J. Noble, Min-max similarity: A contrastive semi-supervised deep learning network for surgical tools segmentation, *IEEE Transactions on Medical Imaging* (2023).
- [62] Z. Wang, C. Vandersteen, T. Demarcy, D. Gnansia, C. Raffaelli, N. Guevara, H. Delingette, Inner-ear augmented metal artifact reduction with simulation-based 3d generative adversarial networks, *Computerized Medical Imaging and Graphics* 93 (2021) 101990.
- [63] J. Wang, Y. Zhao, J. H. Noble, B. M. Dawant, Conditional generative adversarial networks for metal artifact reduction in ct images of the ear, in: *Medical Image Computing and Computer Assisted Intervention–MICCAI 2018: 21st International Conference, Granada, Spain, September 16–20, 2018, Proceedings, Part I*, Springer, 2018, pp. 3–11.
- [64] Y. Lu, S. Yang, Z. Xu, J. Wang, Speech training system for hearing impaired individuals based on automatic lip-reading recognition, in: *Advances in Human Factors and Systems Interaction: Proceedings of the AHFE 2020 Virtual Conference on Human Factors and Systems Interaction, July 16–20, 2020, USA*, Springer, 2020, pp. 250–258.

- [65] M. Jeyalakshmi, C. R. Robin, D. Doreen, Predicting cochlear implants score with the aid of reconfigured long short-term memory, *Multimedia Tools and Applications* 82 (8) (2023) 12537–12556.
- [66] M. Meeuws, D. Pascoal, S. Janssens de Varebeke, G. De Ceulaer, P. J. Govaerts, Cochlear implant telemedicine: remote fitting based on psychoacoustic self-tests and artificial intelligence, *Cochlear Implants International* 21 (5) (2020) 260–268.
- [67] J. Wathour, P. J. Govaerts, E. Lacroix, D. Naïma, Effect of a ci programming fitting tool with artificial intelligence in experienced cochlear implant patients, *Otology & Neurotology* 44 (3) (2023) 209–215.
- [68] Z. Wang, C. Vandersteen, T. Demarcy, D. Gnansia, C. Raffaelli, N. Guevara, H. Delingette, Deep learning based metal artifacts reduction in post-operative cochlear implant ct imaging, in: *Medical Image Computing and Computer Assisted Intervention–MICCAI 2019: 22nd International Conference, Shenzhen, China, October 13–17, 2019, Proceedings, Part VI 22*, Springer, 2019, pp. 121–129.
- [69] T. Gajęcki, W. Nogueira, Deep learning models to remix music for cochlear implant users, *The Journal of the Acoustical Society of America* 143 (6) (2018) 3602–3615.
- [70] S. Hochreiter, J. Schmidhuber, Long short-term memory, *Neural computation* 9 (8) (1997) 1735–1780.
- [71] K. Greff, R. K. Srivastava, J. Koutník, B. R. Steunebrink, J. Schmidhuber, LSTM: A search space odyssey, *IEEE transactions on neural networks and learning systems* 28 (10) (2016) 2222–2232.
- [72] K. Chu, L. Collins, B. Mainsah, A causal deep learning framework for classifying phonemes in cochlear implants, in: *ICASSP 2021–2021 IEEE International Conference on Acoustics, Speech and Signal Processing (ICASSP)*, IEEE, 2021, pp. 6498–6502.
- [73] E. H.-H. Huang, R. Chao, Y. Tsao, Electrodenet—a deep learning based sound coding strategy for cochlear implants, *IEEE Transactions on Cognitive and Developmental Systems* (2023).
- [74] Y. Fan, D. Zhang, R. Banalagay, J. Wang, J. H. Noble, B. M. Dawant, Hybrid active shape and deep learning method for the accurate and robust segmentation of the intracochlear anatomy in clinical head ct and cbct images, *Journal of Medical Imaging* 8 (6) (2021) 064002–064002.
- [75] F. Heutink, V. Koch, B. Verbist, W. J. van der Woude, E. Mylanus, W. Huinck, I. Sechopoulos, M. Caballo, Multi-scale deep learning framework for cochlea localization, segmentation and analysis on clinical ultra-high-resolution ct images, *Computer methods and programs in biomedicine* 191 (2020) 105387.
- [76] A. Gueriani, H. Kheddar, A. C. Mazari, Deep reinforcement learning for intrusion detection in iot: A survey, in: *2023 2nd International Conference on Electronics, Energy and Measurement (IC2EM)*, Vol. 1, 2023, pp. 1–7. doi:10.1109/IC2EM59347.2023.10419560.
- [77] P. López Diez, J. V. Sundgaard, F. Patou, J. Margeta, R. R. Paulsen, Facial and cochlear nerves characterization using deep reinforcement learning for landmark detection, in: *Medical Image Computing and Computer Assisted Intervention–MICCAI 2021: 24th International Conference, Strasbourg, France, September 27–October 1, 2021, Proceedings, Part IV 24*, Springer, 2021, pp. 519–528.
- [78] Y.-H. Lai, Y. Tsao, X. Lu, F. Chen, Y.-T. Su, K.-C. Chen, Y.-H. Chen, L.-C. Chen, L. P.-H. Li, C.-H. Lee, Deep learning-based noise reduction approach to improve speech intelligibility for cochlear implant recipients, *Ear and hearing* 39 (4) (2018) 795–809.
- [79] E. W. Healy, S. E. Yoho, J. Chen, Y. Wang, D. Wang, An algorithm to increase speech intelligibility for hearing-impaired listeners in novel segments of the same noise type, *The Journal of the Acoustical Society of America* 138 (3) (2015) 1660–1669.
- [80] Y. Hu, P. C. Loizou, Environment-specific noise suppression for improved speech intelligibility by cochlear implant users, *The Journal of the Acoustical Society of America* 127 (6) (2010) 3689–3695.
- [81] B. Banerjee, L. L. Mendel, J. K. Dutta, H. Shabani, S. Najnin, Identifying hearing deficiencies from statistically learned speech features for personalized tuning of cochlear implants, in: *Workshops at the Twenty-Ninth AAAI Conference on Artificial Intelligence*, 2015.
- [82] L. P.-H. Li, J.-Y. Han, W.-Z. Zheng, R.-J. Huang, Y.-H. Lai, Improved environment-aware-based noise reduction system for cochlear implant users based on a knowledge transfer approach: Development and usability study, *Journal of medical Internet research* 23 (10) (2021) e25460.
- [83] J. Margeta, R. Hussain, P. López Diez, A. Morgenstern, T. Demarcy, Z. Wang, D. Gnansia, O. Martinez Manzanera, C. Vandersteen, H. Delingette, et al., A web-based automated image processing research platform for cochlear implantation-related studies, *Journal of Clinical Medicine* 11 (22) (2022) 6640.
- [84] Y. Chi, J. Wang, Y. Zhao, J. H. Noble, B. M. Dawant, A deep-learning-based method for the localization of cochlear implant electrodes in ct images, in: *2019 IEEE 16th International Symposium on Biomedical Imaging (ISBI 2019)*, IEEE, 2019, pp. 1141–1145.
- [85] Z. Li, L. Zhou, S. Tan, A. Tang, Application of unetr for automatic cochlear segmentation in temporal bone cts, *Auris Nasus Larynx* 50 (2) (2023) 212–217.
- [86] D. Zhang, R. Banalagay, J. Wang, Y. Zhao, J. H. Noble, B. M. Dawant, Two-level training of a 3d u-net for accurate segmentation of the intra-cochlear anatomy in head cts with limited ground truth training data, in: *Medical Imaging 2019: Image Processing*, Vol. 10949, SPIE, 2019, pp. 45–52.
- [87] R. Hussain, A. Frater, R. Calixto, C. Karoui, J. Margeta, Z. Wang, M. Hoen, H. Delingette, F. Patou, C. Raffaelli, et al., Anatomical variations of the human cochlea using an image analysis tool, *Journal of Clinical Medicine* 12 (2) (2023) 509.
- [88] M. Regodic, Z. Bardosi, W. Freysinger, Automatic fiducial marker detection and localization in ct images: a combined approach, in: *Medical Imaging 2020: Image-Guided Procedures, Robotic Interventions, and Modeling*, Vol. 11315, SPIE, 2020, pp. 507–514.
- [89] M. Li, Z. Fang, W. Cong, C. Niu, W. Wu, J. Uher, J. Bennett, J. T. Rubinstein, G. Wang, Clinical micro-ct empowered by interior tomography, robotic scanning, and deep learning, *IEEE Access* 8 (2020) 229018–229032.
- [90] D. Kügler, J. Sehring, A. Stefanov, I. Stenin, J. Kristin, T. Klenzner, J. Schipper, A. Mukhopadhyay, i3posnet: instrument pose estimation from x-ray in temporal bone surgery, *International journal of computer assisted radiology and surgery* 15 (2020) 1137–1145.
- [91] S. Waldeck, R. Helal, I. Al-Dhamari, S. Schmidt, C. von Falck, R. Chapot, M. Brockmann, D. Overhoff, New ultra-fast algorithm for cochlear implant misalignment detection, *European Journal of Radiology* 151 (2022) 110283.
- [92] K. Chen, Q. Li, W. Li, H. Lau, A. Ruys, P. Carter, Three-dimensional finite element modeling of cochlear implant induced electrical current flows, in: *2009 IEEE International Conference on Computational Intelligence for Measurement Systems and Applications*, IEEE, 2009, pp. 5–7.
- [93] F. A. Reda, T. R. McRackan, R. F. Labadie, B. M. Dawant, J. H. Noble, Automatic segmentation of intra-cochlear anatomy in post-implantation ct of unilateral cochlear implant recipients, *Medical image analysis* 18 (3) (2014) 605–615.
- [94] S. S. Moudgalya, N. D. Cahill, D. A. Borkholder, Deep volumetric segmentation of murine cochlear compartments from micro-computed tomography images, in: *2020 42nd Annual International Conference of the IEEE Engineering in Medicine & Biology Society (EMBC)*, IEEE, 2020, pp. 1970–1975.
- [95] J. Wang, J. H. Noble, B. M. Dawant, Metal artifact reduction and intra cochlear anatomy segmentation in ct images of the ear with a multi-resolution multi-task 3d network, in: *2020 IEEE 17th International Symposium on Biomedical Imaging (ISBI)*, IEEE, 2020, pp. 596–599.
- [96] A. M. Kuczapski, A. Stanciu, Assistive tool for cochlear implant fitting: Estimation and monitoring of the effective stimulation thresholds, in: *2015 IEEE 10th Jubilee International Symposium on Applied Computational Intelligence and Informatics*, IEEE, 2015, pp. 307–311.
- [97] A. Botros, B. van Dijk, M. Killian, Autornr™: An automated system that measures ecap thresholds with the nucleus® freedom™ cochlear implant via machine intelligence, *Artificial Intelligence in Medicine* 40 (1) (2007) 15–28.
- [98] J. H. Noble, B. M. Dawant, Automatic graph-based localization of cochlear implant electrodes in CT, in: *Medical Image Computing and Computer-Assisted Intervention–MICCAI 2015: 18th International Conference, Munich, Germany, October 5-9, 2015, Proceedings, Part II 18*, Springer, 2015, pp. 152–159.
- [99] Y. Zhao, B. M. Dawant, R. F. Labadie, J. H. Noble, Automatic localization of cochlear implant electrodes in ct, in: *Medical Image Computing and Computer-Assisted Intervention–MICCAI 2014: 17th International Conference, Boston, MA, USA, September 14-18, 2014, Proceedings, Part I 17*, Springer, 2014, pp. 331–338.
- [100] Y. Zhao, S. Chakravorti, R. F. Labadie, B. M. Dawant, J. H. Noble, Automatic graph-based method for localization of cochlear implant electrode arrays in clinical ct with sub-voxel accuracy, *Medical image analysis* 52 (2019) 1–12.

- [101] I. Bermejo, F. J. Díez, P. Govaerts, B. Vaerenberg, A probabilistic graphical model for tuning cochlear implants, in: Conference on Artificial Intelligence in Medicine in Europe, Springer, 2013, pp. 150–155.
- [102] N. Castaneda-Villa, C. James, Objective source selection in blind source separation of aeps in children with cochlear implants, in: 2007 29th Annual International Conference of the IEEE Engineering in Medicine and Biology Society, IEEE, 2007, pp. 6223–6226.
- [103] P. V. Incerti, T. Y. Ching, R. Cowan, The effect of cross-over frequency on binaural hearing performance of adults using electric-acoustic stimulation, Cochlear implants international 20 (4) (2019) 190–206.
- [104] J. R. Katthi, S. Ganapathy, S. Kothinti, M. Slaney, Deep canonical correlation analysis for decoding the auditory brain, in: 2020 42nd Annual International Conference of the IEEE Engineering in Medicine & Biology Society (EMBC), IEEE, 2020, pp. 3505–3508.
- [105] T. Gajeccki, W. Nogueira, A fused deep denoising sound coding strategy for bilateral cochlear implants, IEEE Transactions on Biomedical Engineering (2024).
- [106] Y. Himeur, I. Varlamis, H. Kheddar, A. Amira, S. Atalla, Y. Singh, F. Bensaali, W. Mansoor, Federated learning for computer vision, arXiv preprint arXiv:2308.13558 (2023).
- [107] N. Djeflal, H. Kheddar, D. Addou, A. C. Mazari, Y. Himeur, Automatic speech recognition with bert and ctc transformers: A review, in: 2023 2nd International Conference on Electronics, Energy and Measurement (IC2EM), Vol. 1, 2023, pp. 1–8. doi:10.1109/IC2EM59347.2023.10419784.
- [108] H. Kheddar, M. Hemis, Y. Himeur, Automatic speech recognition using advanced deep learning approaches: A survey (2024). arXiv:2403.01255.