

GENERALIZABLE TWO-BRANCH FRAMEWORK FOR IMAGE CLASS-INCREMENTAL LEARNING

Chao Wu¹, Xiaobin Chang^{1,*}, Ruixuan Wang²

¹School of Artificial Intelligence, Sun Yat-sen University, China

²School of Computer Science and Engineering, Sun Yat-sen University, China

ABSTRACT

Deep neural networks often severely forget previously learned knowledge when learning new knowledge. Various continual learning (CL) methods have been proposed to handle such a catastrophic forgetting issue from different perspectives and achieved substantial improvements. In this paper, a novel two-branch continual learning framework is proposed to further enhance most existing CL methods. Specifically, the main branch can be any existing CL model and the newly introduced side branch is a lightweight convolutional network. The output of each main branch block is modulated by the output of the corresponding side branch block. Such a simple two-branch model can then be easily implemented and learned with the vanilla optimization setting without whistles and bells. Extensive experiments with various settings on multiple image datasets show that the proposed framework yields consistent improvements over state-of-the-art methods.

Index Terms— Incremental Learning, Neural Networks, Image classification

1. INTRODUCTION

One exceptional ability of humans is to continually learn and accumulate knowledge over time. However, current deep neural network models would catastrophically forget previously learned knowledge when learning new knowledge [1, 2]. Since knowledge is implicitly stored in model parameters, the change in model parameters during continual learning of new knowledge would inevitably deteriorate model memory of old knowledge. Taking the class-incremental learning (CIL) setting as an example, the attention of old task image features extracted by the network learned on the new tasks drifts away from the discriminative areas (Figure 1, first row), resulting in inferior performance.

To alleviate the catastrophic forgetting issue, multiple approaches have been proposed to help deep learning models achieve the continual learning ability, either by trying to keep model parameters or model responses relevant to old knowledge from changing [3, 4, 5, 6], rehearsing old knowledge with a preserved small subset of old data [7, 8, 9, 10],

* indicates corresponding author.

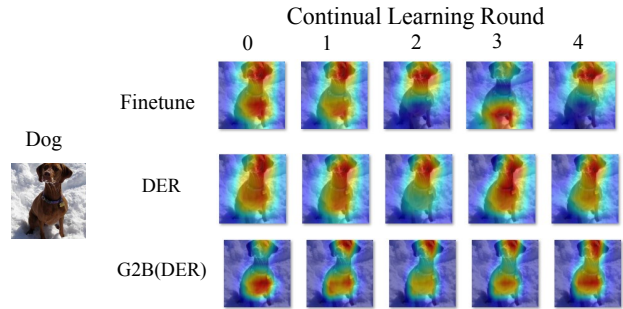

Fig. 1: The feature attention maps from different methods are illustrated. The ‘Dog’ class only appears in round 0 during continual learning. The models are then continually updated with other classes at different rounds. ‘Finetune’: model is simply finetuned across rounds. ‘DER’: a CL method. ‘G2B(DER)’: our G2B framework with DER.

or dynamically growing the model components specifically for new knowledge [11, 12, 13, 14]. Jointly applying the rehearsal and dynamic growth strategies, e.g. DyTox [11] and DER [12], have achieved state-of-the-art performance in class-incremental learning of image classes. As shown in Figure 1 (second row), the catastrophic forgetting issue can be alleviated by DER as its feature attention areas are more discriminative and consistent than the baseline ‘Finetune’ across rounds of learning.

In this paper, a simple yet effective generalizable two-branch (G2B) framework is proposed to enhance the performance of existing strategies. Specifically, the main branch can be any existing continual learning strategy based on a convolutional neural network (CNN) or vision transformer (ViT), and the lightweight side branch is an independent convolutional network. The side branch interacts with the main branch such that the output of each block in the main branch is modulated by the output of the corresponding block in the side branch, resulting in relatively sparse activations as the outputs of the main branch blocks. With such sparse activated outputs, the proposed method can be more resistant to the forgetting problem in continual learning. As illustrated in Figure 1 (last row), the attention maps of the sparsely acti-

vated features of our method are kept compact and focus on the discriminative visual areas. Training the G2B framework is painless as the vanilla optimization setting can be applied directly. Extensive empirical evaluations on multiple image datasets show that the G2B framework yields consistent improvements over state-of-the-art methods.

2. METHODOLOGY

In class-incremental learning (CIL), the model is trained from an ordered sequence of datasets. When the model is updated to learn a set of new classes with associated training data each time, it assumes that there is no or only very few old data available for each of the previously learned (old) classes. Thus, changes in model parameters during continual learning would make the updated model have seriously biased predictions toward recently learned new classes. In other words, some model parameters which are crucial to the knowledge preservation of old classes may be changed during learning new classes, causing the updated model to catastrophically forget at least part of old knowledge.

To reduce the possibility of changing model parameters relevant to old knowledge, one way is to update only part of model parameters (e.g., kernels in CNN classifier) during learning new classes of knowledge. With this consideration, we propose a two-branch framework where the side branch modulates the activation of the main branch at each block, such that a relatively smaller number of model components in the main branch are updated during continual learning.

2.1. The two-branch framework

The proposed framework consists of two branches, as illustrated in Figure 2(a). The main branch can be any existing deep learning framework for continual learning, e.g., iCaRL and DER with a CNN backbone or DyTox with a Transformer backbone. The side branch is a lightweight convolutional network which has the same number of blocks as the main branch and each block consists of only two convolutional layers, as depicted in Figure 2 (b) and (c). Therefore, it can be considered as a *plug-in* module for any existing continual learning framework. The side branch interacts with the main branch at each block, using the output of the side branch as a soft mask to modulate the output of the main branch at each block. Formally, given any input image \mathbf{x} , denote by $\mathbf{F}_i(\mathbf{x})$ and $\mathbf{M}_i(\mathbf{x})$ the original outputs of the i -block respectively from the main branch and the side branch. Then, the modulated output $\hat{\mathbf{F}}_i$ for the i -block of the main branch can be obtained by

$$\hat{\mathbf{F}}_i(\mathbf{x}) = \mathbf{F}_i(\mathbf{x}) \odot g(\mathbf{M}_i(\mathbf{x})), \quad (1)$$

where \odot is the Hadamard product operator, and $g(\cdot)$ is an adapter function particularly for heterogeneous model backbones between the two branches.

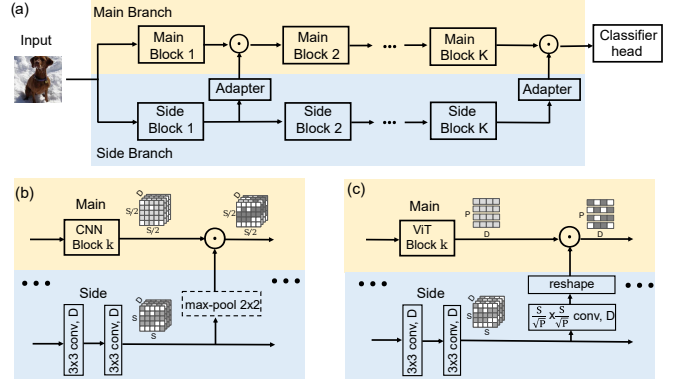

Fig. 2: The proposed two-branch framework for continual learning. The main branch (shown in yellow background) can be any continual learning framework with either CNN or Transformer backbone, and the side branch (shown in blue background) is a lightweight CNN. (a) The output of a main block is modulated by the corresponding side block. (b-c) Design of each side block and the adapter respectively for the CNN backbone and the ViT backbone of the main branch. Note that the BN and ReLU operators following the convolutional operator in each side block are omitted for simplicity.

When the model backbone of the main branch is a CNN, the number of kernels in each side block is designed to be consistent with those of the corresponding main block, as shown in Figure 2(b). Specifically, the number of kernels in each convolutional layer of the side block is set to be the same as that of the output feature channels from the corresponding main block. For adapter design, if the spatial size of the original output feature maps from the main block is smaller (e.g., due to pooling) than that of the side block output, the adapter $g(\cdot)$ is designed as a max pooling operator (e.g., max over local regions of size 2×2 elements with step size 2) to reduce the spatial size of side block output such that two outputs have the same spatial size and the same number of feature channels. Otherwise, the adapter $g(\cdot)$ is simply an identity function. For instance, when the baseline iCaRL [10] with the CNN backbone ResNet is adopted as the main branch for the proposed G2B framework, the adapter $g(\cdot)$ for the first residual block is a max pooling operator, while the adapters for the remaining blocks are simply identity functions.

When a Transformer backbone is used in the main branch, the number of kernels in each convolutional layer of the side block is set to the length of the output vector for each token in the corresponding main block. The adapter $g(\cdot)$ is designed as a simple convolutional layer followed by a reshape operator such that the transformed output of the side branch by the adapter has the same dimension as that of the corresponding main block output, as detailed in Figure 2(c). Specifically, suppose the dimension of the main block output is $[D, P]$, where P is the number of tokens (with each

Table 1: Representative CIL methods with their main strategies and model backbones. ‘RH’, ‘RG’ and ‘DE’ correspond to the CL strategies, ‘Rehearsal-based’, ‘Regularization-based’ and ‘Dynamic Expansion’, respectively.

Method	iCaRL[10]	BiC[6]	WA[15]	PODNet[3]	DER[12]	DyTox[11]
Strategy	RH	RG	RG	RG	DE	DE
Backbone	CNN	CNN	CNN	CNN	CNN	ViT

token corresponding to one local image patch) and D is the length of vector output for each token, and the dimension of the corresponding side block output is $[D, S, S]$, where S is both width and height of the output feature maps. Then the adaptor $g(\cdot)$ contains D convolutional kernels with kernel size $[S/\sqrt{P}, S/\sqrt{P}]$ and convolution step size S/\sqrt{P} (S/\sqrt{P} being an integer number in practice). The dimension (i.e., $[D, \sqrt{P}, \sqrt{P}]$) of the adaptor output is reshaped to $[D, P]$ by simply re-ordering the D -dimensional feature vectors across all spatial locations in the adaptor output such that each feature vector in the reshaped adaptor output matches one token’s output vector in the corresponding main block. Taking DyTox [11] as an example. Its ViT backbone network serves as the main branch of the G2B framework. Each Transformer block F_i has a corresponding convolutional block M_i that generates a corresponding soft mask through the adaptor $g(\cdot)$.

The training of the proposed G2B framework is straightforward. Its main and side branches are jointly optimized in an end-to-end manner. The losses used in the vanilla method can be directly inherited by G2B. No extra loss is introduced. The optimization settings, e.g., learning rate and optimizer, of G2B are kept consistent with those in the vanilla method.

3. EXPERIMENTS

Datasets and protocols. CIFAR-100 [16], ImageNet-100 and ImageNet-1000 [17] are widely used benchmarks for CIL. CIFAR-100 consists of 32×32 RGB images of 100 object categories. It contains 50,000 training samples with 500 images per class and 10,000 testing images with 100 samples per class. ImageNet-1000 is a large-scale vision dataset of 1,000 object categories and includes approximately 1.2 million RGB images for training and 50,000 images for validation. ImageNet-100 is a subset of the 100 classes in ImageNet-1000 and the same 100 classes as in DER and DyTox are used. The CIL protocols in DyTox [11] and DER [12] are followed for fair comparisons. On CIFAR-100, the models are gradually trained with 10, 5 or 2 new classes per round (task), resulting in three continual learning procedures: 10 rounds, 20 rounds or 50 rounds of continual learning, respectively. The fixed rehearsal memory size is 2,000 exemplars. The CIL procedure on ImageNet includes 10 rounds of continual learning. For ImageNet-100, each round provides the training samples of 10 new classes with a fixed memory size of 2,000. For ImageNet-1000, each round provides the training samples of 100 new classes with a fixed memory size of

Table 2: CIL Results (%) on CIFAR-100.

Method	Strategy & Backbone	10 rounds		20 rounds		50 rounds	
		Avg	Last	Avg	Last	Avg	Last
Joint Learning	- & CNN - & ViT	-	80.41 76.12	-	81.49 76.12	-	81.74 76.12
iCaRL	RH & CNN	65.71	52.97	61.20	43.75	56.08	36.62
G2B(iCaRL)	RH & CNN	68.57(\uparrow 2.86)	55.75(\uparrow 2.78)	65.12(\uparrow 3.92)	46.81(\uparrow 3.06)	58.21(\uparrow 2.13)	38.78(\uparrow 2.16)
BiC	RG & CNN	68.83	52.71	66.48	47.02	62.09	41.04
G2B(BiC)	RG & CNN	71.11(\uparrow 2.28)	54.63(\uparrow 1.92)	68.21(\uparrow 1.73)	49.43(\uparrow 2.41)	64.13(\uparrow 2.04)	42.32(\uparrow 1.28)
WA	RG & CNN	70.10	53.68	67.33	47.31	64.32	42.14
G2B(WA)	RG & CNN	73.45(\uparrow 3.35)	58.58(\uparrow 4.90)	69.81(\uparrow 2.48)	50.32(\uparrow 3.01)	65.81(\uparrow 1.49)	44.35(\uparrow 2.21)
PODNet	RG & CNN	61.21	42.10	53.97	35.02	51.19	32.99
G2B(PODNet)	RG & CNN	65.05(\uparrow 3.84)	44.07(\uparrow 1.97)	56.31(\uparrow 2.34)	36.19(\uparrow 1.17)	53.12(\uparrow 1.93)	35.12(\uparrow 2.13)
DER	DE & CNN	76.08	66.59	74.09	62.48	72.41	59.08
G2B(DER)	DE & CNN	77.26(\uparrow 1.18)	68.36(\uparrow 1.77)	74.95(\uparrow 0.86)	63.15(\uparrow 0.67)	73.81(\uparrow 1.40)	59.86(\uparrow 0.78)
DyTox	DE & ViT	73.66	60.67	72.27	56.32	70.20	52.34
G2B(DyTox)	DE & ViT	76.32(\uparrow 2.66)	64.32(\uparrow 3.65)	75.30(\uparrow 3.03)	61.04(\uparrow 4.72)	73.01(\uparrow 2.81)	55.88(\uparrow 3.54)

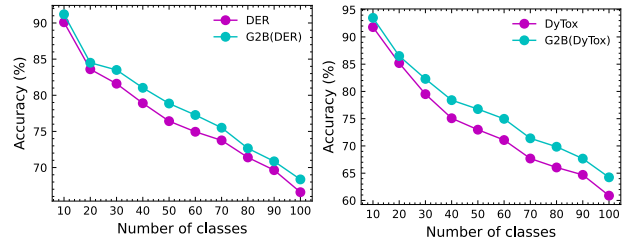

Fig. 3: Comparisons between the G2B framework and corresponding methods, DER (left) and DyTox (right), on CIFAR-100 under 10 rounds of continual learning.

20,000. After each learning round, the classification accuracy of all the classes learned so far in the test set is obtained. After finishing the last round of continual learning, both the averaged classification accuracy over all rounds (denoted as Avg) and the last-round accuracy (denoted as Last) are reported.

Vanilla CIL methods. Our G2B framework is proposed to further enhance the performance of existing CL methods. As shown in Table 1, six representative CIL methods are chosen to compare and combine with our G2B. ResNet18 [18] is the default CNN backbone that existing CIL methods have widely adopted, and the ViT backbone is adopted from DyTox [11]. Training a G2B model can be done with the vanilla optimization setting applied directly.

3.1. Main Results

The proposed G2B framework along with the corresponding CIL methods are first evaluated on CIFAR-100 dataset, as shown in Table 2. Joint learning indicates the backbone networks are optimized with all training samples and depicts the upper-bound performance of continual learning. Combining our G2B framework with the vanilla CIL methods results in clear and consistent improvements. Specifically, it boosts the performance of the SOTA methods, DER and DyTox, to new peaks. Combining DER with G2B brings consistent improvements, usually more than 1%, on all criteria. DyTox also substantially benefits from the G2B framework, with significant improvements observed, more than 2.6%. The effectiveness of G2B in defying catastrophic forgetting can be further demonstrated in Figure 3 where the performance of DER and DyTox is evaluated at the end of each continual learning

Table 3: Ten rounds of CIL results (%) on ImageNet-100.

Method	Top-1		Top-5	
	Avg	Last	Avg	Last
iCaRL	68.22	53.02	87.68	75.64
G2B(iCaRL)	69.12(↑0.90)	54.14(↑1.12)	87.98(↑0.30)	76.64(↑1.00)
BiC	65.39	48.76	85.31	69.62
G2B(BiC)	68.13(↑2.74)	51.48(↑2.72)	87.29(↑1.98)	72.54(↑2.92)
WA	70.28	57.42	89.30	80.24
G2B(WA)	73.56(↑3.28)	61.64(↑4.22)	91.31(↑2.01)	84.14(↑3.90)
DER	77.05	66.28	93.42	87.66
G2B(DER)	79.22(↑2.17)	69.21(↑2.93)	93.87(↑0.45)	87.99(↑0.33)
DyTox	77.15	69.10	92.04	87.98
G2B(DyTox)	80.91(↑3.76)	69.94(↑0.84)	94.58(↑2.54)	90.38(↑2.40)

Table 4: Ten rounds of CIL results (%) on ImageNet-1000.

Method	Top-1		Top-5	
	Avg	Last	Avg	Last
WA	65.67	55.60	86.60	81.10
G2B(WA)	67.17(↑1.50)	58.92(↑3.32)	88.61(↑2.01)	83.12(↑2.02)
DER	68.84	60.16	88.17	82.86
G2B(DER)	69.56(↑0.72)	62.13(↑1.97)	89.19(↑1.02)	83.24(↑0.38)
DyTox	71.29	63.34	88.59	84.49
G2B(DyTox)	73.16(↑1.87)	63.87(↑0.53)	89.37(↑0.78)	86.62(↑2.13)

round. The initial results of the vanilla method and with G2B are similar. As continual learning progresses, the G2B framework consistently achieves better results than its counterpart.

Our G2B framework is also evaluated on the two ImageNet datasets. ImageNet-100 results are shown in Table 3 and the ImageNet-1000 ones are summarized in Table 4. The latter one could be a more challenging CIL setting with more categories and data samples to be handled at each learning round. However, both tables show that combining the vanilla CIL methods with our G2B framework consistently increases their performance with clear margins. In addition, new SOTA results are achieved by G2B(DER) and G2B(DyTox).

3.2. Detailed Analysis

Effect of the side branch network. As illustrated in Figure 2, G2B contains two parallel networks. To evaluate the contributions of the newly introduced side branch, the side branch blocks are gradually removed, and the performance is reported in Table 5. The side branch network with two blocks consistently brings noticeable improvement over the vanilla method. With more blocks used in the side branch, better results are obtained. The complete G2B, where each main block has the corresponding side block, achieves the best results.

Impact of model size. The performance of models under varied parameter sizes are compared in Table 6. Strengthening the vanilla method, WA, from 11.2M to 21.5M parameters brings only marginal improvements. The proposed G2B is insensitive to smaller model sizes and consistently better than WA. To demonstrate the superior stability of our G2B framework, the forgetting measure (F) [19] is used. We report F_{10} to measure this forgetting of the final (10th) round model. As shown in the last column of Table 6, the F values of G2B are much lower than those of WA.

Table 5: The effect of G2B side branch network, with 10-round CIL results of CIFAR-100 and ImageNet-100 reported. #P: the number of (million) parameters of a model. ‘-’: not applicable because of only four blocks for the main branch.

Method	Side Branch Blocks					#P	CIFAR-100		ImageNet-100	
	1	2	3	4	5		Avg	Last	Avg	Last
WA	✓				-	11.2	70.16	53.19	70.28	57.42
	✓	✓			-	11.3	70.52	53.21	72.17	57.00
	✓	✓	✓		-	12.0	71.47	55.09	72.52	58.28
	✓	✓	✓	✓	-	13.5	73.45	58.58	73.56	61.64
DyTox	✓					11.0	73.66	60.67	77.15	69.10
	✓	✓				11.9	73.82	60.52	77.61	68.98
	✓	✓	✓			12.5	74.15	61.56	78.67	69.16
	✓	✓	✓	✓		13.1	74.58	62.15	80.14	69.48
	✓	✓	✓	✓	✓	13.7	75.62	63.18	80.58	69.89
	✓	✓	✓	✓	✓	14.3	76.32	64.32	80.91	69.94

Table 6: Impact of model size. Ten-round of CIL results on CIFAR-100 are reported. ResNet18 is the backbone network.

Methods	#P	Avg	Last	F_{10} (↓)
WA	11.2M	70.16	53.19	0.3437
	14.5M	70.69	54.11	0.3408
	21.5M	71.53	54.29	0.3559
G2B(WA)	7.81M	73.14	57.81	0.2430
	10.6M	73.93	58.92	0.2340
	13.5M	73.45	58.58	0.2659

Table 7: Comparing G2B with AANets, with 10/20-round CIL results (%) on CIFAR-100. ResNet18 is the backbone.

	Memory	FLOPs	10	20
iCaRL	11.38MB	557.4M	65.71	61.20
AANets(iCaRL)	21.73MB	1114.8M	62.49	59.35
G2B(iCaRL)	19.28MB	704.7M	68.57	65.12

Comparing two-branch frameworks. Both our G2B and AANet [20] are two-branch network architectures. As shown in Table 7, AANets requires more memory and computation resources than the vanilla iCaRL and our G2B method but achieves the worst performance.

4. CONCLUSION

We propose a simple yet effective generalizable two-branch (G2B) framework for continual learning. With the lightweight convolutional network as the side branch, the outputs in the main branch are modulated for relative sparsity and thus alleviating catastrophic forgetting. G2B is compatible with different continual learning strategies based on either CNN or ViT. Their combinations are straightforward and the optimization is painless. Comprehensive evaluations on multiple image classification tasks demonstrate the state-of-the-art continual learning performance of the G2B framework. We expect that G2B can be extended to continual learning of object detection and semantic segmentation tasks.

Acknowledgement. This research is supported by the National Natural Science Foundation for Young Scientists of China (No. 62106289).

5. REFERENCES

- [1] Robert M French, “Catastrophic forgetting in connectionist networks,” *Trends in Cognitive Sciences*, 1999.
- [2] Michael McCloskey and Neal J Cohen, “Catastrophic interference in connectionist networks: The sequential learning problem,” *Trends in Cognitive Sciences*, 1989.
- [3] Arthur Douillard, Matthieu Cord, Charles Ollion, Thomas Robert, and Eduardo Valle, “Podnet: Pooled outputs distillation for small-tasks incremental learning,” in *Proceedings of the IEEE European Conference on Computer Vision (ECCV)*, 2020.
- [4] Zhizhong Li and Derek Hoiem, “Learning without forgetting,” in *Proceedings of the IEEE European Conference on Computer Vision (ECCV)*, 2016.
- [5] James Kirkpatrick, Razvan Pascanu, Neil C. Rabinowitz, Joel Veness, Guillaume Desjardins, Andrei A. Rusu, Kieran Milan, John Quan, Tiago Ramalho, Agnieszka Grabska-Barwinska, Demis Hassabis, Claudia Clopath, Dharshan Kumaran, and Raia Hadsell, “Overcoming catastrophic forgetting in neural networks,” *Proceedings of the National Academy of Sciences*, 2016.
- [6] Yue Wu, Yinpeng Chen, Lijuan Wang, Yuancheng Ye, Zicheng Liu, Yandong Guo, and Yun Fu, “Large scale incremental learning,” in *IEEE Conference on Computer Vision and Pattern Recognition (CVPR)*, 2019.
- [7] Pietro Buzzega, Matteo Boschini, Angelo Porrello, Davide Abati, and Simone Calderara, “Dark experience for general continual learning: a strong, simple baseline,” in *Advances in Neural Information Processing Systems (NeurIPS)*, 2020.
- [8] Ari S. Benjamin, David Rolnick, and Konrad P. Körding, “Measuring and regularizing networks in function space,” in *Proceedings of the International Conference on Learning Representations (ICLR)*, 2019.
- [9] Arslan Chaudhry, Marc’Aurelio Ranzato, Marcus Rohrbach, and Mohamed Elhoseiny, “Efficient lifelong learning with A-GEM,” in *Proceedings of the International Conference on Learning Representations (ICLR)*, 2019.
- [10] Sylvestre-Alvise Rebuffi, Alexander Kolesnikov, Georg Sperl, and Christoph H. Lampert, “icarl: Incremental classifier and representation learning,” in *Proceedings of the IEEE Conference on Computer Vision and Pattern Recognition (CVPR)*, 2017.
- [11] Arthur Douillard, Alexandre Ramé, Guillaume Couairon, and Matthieu Cord, “Dytox: Transformers for continual learning with dynamic token expansion,” in *Proceedings of the IEEE Conference on Computer Vision and Pattern Recognition (CVPR)*, 2022.
- [12] Shipeng Yan, Jiangwei Xie, and Xuming He, “DER: dynamically expandable representation for class incremental learning,” in *Proceedings of the IEEE Conference on Computer Vision and Pattern Recognition (CVPR)*, 2021.
- [13] Jaehong Yoon, Eunho Yang, Jeongtae Lee, and Sung Ju Hwang, “Lifelong learning with dynamically expandable networks,” in *Proceedings of the International Conference on Learning Representations (ICLR)*, 2018.
- [14] Jeffrey O. Zhang, Alexander Sax, Amir Zamir, Leonidas J. Guibas, and Jitendra Malik, “Side-tuning: A baseline for network adaptation via additive side networks,” in *Proceedings of the IEEE European Conference on Computer Vision (ECCV)*, 2020.
- [15] Bowen Zhao, Xi Xiao, Guojun Gan, Bin Zhang, and Shu-Tao Xia, “Lifelong learning with dynamically expandable networks,” in *Proceedings of the IEEE Conference on Computer Vision and Pattern Recognition (CVPR)*, 2020.
- [16] Alex Krizhevsky, Geoffrey Hinton, et al., “Learning multiple layers of features from tiny images,” *Technical Report*, 2009.
- [17] Jia Deng, Wei Dong, Richard Socher, Li-Jia Li, Kai Li, and Li Fei-Fei, “Imagenet: A large-scale hierarchical image database,” in *Proceedings of the IEEE Conference on Computer Vision and Pattern Recognition (CVPR)*, 2009.
- [18] Kaiming He, Xiangyu Zhang, Shaoqing Ren, and Jian Sun, “Deep residual learning for image recognition,” in *Proceedings of the IEEE Conference on Computer Vision and Pattern Recognition (CVPR)*, 2016.
- [19] Arslan Chaudhry, Puneet Kumar Dokania, Thalaiyasingam Ajanthan, and Philip H. S. Torr, “Riemannian walk for incremental learning: Understanding forgetting and intransigence,” in *Proceedings of the IEEE European Conference on Computer Vision (ECCV)*, 2018.
- [20] Yaoyao Liu, Bernt Schiele, and Qianru Sun, “Adaptive aggregation networks for class-incremental learning,” in *Proceedings of the IEEE Conference on Computer Vision and Pattern Recognition (CVPR)*, 2021.