Synergy-of-Thoughts: Eliciting Efficient Reasoning in Hybrid Language Models

Yu Shang*

Tsinghua University
Beijing, China
shangy21@mails.tsinghua.edu.cn

Yu Li*

Harbin Institute of Technology
Shenzhen, China
200210623@stu.hit.edu.cn

Fengli Xu

Tsinghua University
Beijing, China
fenglixu@tsinghua.edu.cn

Yong Li

Tsinghua University
Beijing, China
liyong07@tsinghua.edu.cn

Abstract

Large language models (LLMs) have shown impressive emergent abilities in a wide range of tasks, but still face challenges in handling complex reasoning problems. Previous works like chain-of-thought (CoT) and tree-of-thoughts (ToT) have predominately focused on enhancing accuracy, but overlook the rapidly increasing token cost, which could be particularly problematic for open-ended real-world tasks with huge solution spaces. Motivated by the dual process theory of human cognition, we propose “Synergy of Thoughts” (SoT) to unleash the synergistic potential of hybrid LLMs for efficient reasoning. By default, SoT uses smaller-scale language models to generate multiple low-cost reasoning thoughts, which resembles the parallel intuitions produced by *System 1*. If these intuitions exhibit conflicts, SoT will invoke the reflective reasoning of scaled-up language models to emulate the intervention of *System 2*, which will override the intuitive thoughts and rectify the reasoning process. This framework is model-agnostic and training-free, which can be flexibly implemented with various off-the-shelf LLMs. Experiments on six representative reasoning tasks show that SoT substantially reduces the token cost by 38.3%~75.1%, and simultaneously achieves state-of-the-art reasoning accuracy and solution diversity. Notably, the average token cost reduction on open-ended tasks reaches up to 69.1%. Code repo with all prompts will be released upon publication.

1 Introduction

Initially conceived for autoregressive text generation, large language models (LLMs), such as GPT [1, 2, 3] and PaLM [4], have been shown to exhibit emergent abilities for a wide range of tasks as they scale up [5]. A recent landmark study reveals LLMs can unlock their capability of mathematical, commonsense and symbolic reasoning by employing prompts to produce natural language intermediate steps for reasoning. This approach, known as the “Chain of Thought” (CoT) framework [6], adeptly mimics the sequential thought processes of human reasoners. The later “Tree of Thoughts” (ToT) framework [7] further allows LLMs to deliberate on multiple reasoning paths and make high-quality global decisions via tree search. Search methods like ToT are believed to resemble the reflective reasoning mode found in human cognition, offering greater accuracy but at the

*Equal contribution

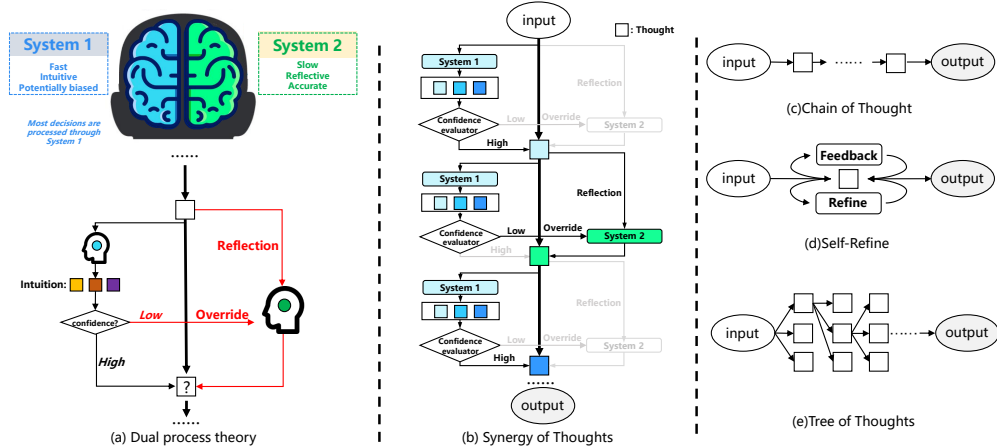

Figure 1: An illustration of dual process theory (a) and the main differences between SoT (b) and prior works (c) (d) (e). SoT is designed following the synergy paradigm of dual processes in human reasoning.

expense of significantly more resources. For example, finding a solution for “Game of 24” with ToT consumes approximately 100 times more tokens compared to CoT [7]. Specifically, many open-ended real-world problems [8] with considerably larger solution spaces could pose significant challenges to this effortful reasoning framework. Consequently, a critical research problem arises for practical LLM reasoning: Can we strike a more effective balance between reasoning accuracy and efficiency? And if possible, how might we integrate these elements into a novel reasoning framework?

Our study is motivated by human’s cognition ability to efficiently tackle complex problems. The prevalent “dual process” theory suggests [9] there are two distinct systems in human reasoning: *System 1*, capable of rapid, preconscious and intuitive responses; and *System 2*, adept at high-effort, reflective reasoning. Research indicates that everyday decision-making is predominantly governed by *System 1* [9], providing fast responses with minimum resources through the intuition of associative experiences. Although *System 1* makes accurate decisions most of the time, it is also identified as the source of various cognitive biases [10], rendering it prone to errors if not properly monitored. On the contrary, *System 2* can avoid intuitive biases through effortful reflection, which is widely encouraged in critical decision-making [11]. Human cognition has been observed to effectively reconcile these two competing systems [12], unleashing their synergistic power to simultaneously enhance both reasoning accuracy and efficiency. However, previous works on LLM reasoning have predominantly focused on boosting the reasoning accuracy with various *System 2*-like deliberation mechanisms [7, 13, 14], often neglecting the efficiency advantage of *System 1*, failing to achieve both efficient and accurate reasoning.

We draw inspiration from the popular *default-interventionist* model in the realm of dual-process theory [12]. It hypothesizes the two competing systems are reconciled by using *System 1* to generate low-effort *default* responses, which may be *intervened* upon with the reflection of high-effort *System 2* if the confidence is low. We thus propose “Synergy of Thoughts” (SoT) for efficient problem-solving with the synergy of hybrid LLMs (see Figure 1). To mimic the fast, low-effort *System 1*, SoT prompts smaller-scale language models to generate *default* reasoning steps efficiently. Specifically, SoT employs a variety of language models from diverse sources to emulate the intuitions derived from different associative experiences (*i.e.*, different pre-training datasets of these language models). The parallel “intuitions” are then cross-evaluated, generating a confidence score measuring the coherence of multiple intuitions. We introduce a progressively increasing threshold to adjust the workload of dual systems, delicately modulating the cost-accuracy trade-off of the reasoning. Should it be deemed necessary, SoT will invoke the intervention of the effortful, reflective *System 2* implemented by scaled-up language models to override the default steps and rectify the reasoning process. With the above designs, SoT is expected to harness the synergistic potential of different-scale LLMs and deliver human-like efficient and accurate reasoning.

Empirically, we conduct extensive experiments on six complex reasoning tasks, including both close-ended (Game of 24 [7], Logic Grid Puzzle [15], GSM8K [16]) and open-ended problems (Trivia Creative Writing [17], Open-ended QA [17], Constrained Generation [18]). The results show that SoT achieves state-of-the-art reasoning accuracy on all six tasks. More importantly, it substantially reduces the token cost by 38.3%~75.1% compared to the second accurate baselines. The token cost reduction in open-ended tasks (69.1% on average) is higher than the close-ended tasks (42.6% on average). Besides, we find SoT can also improve the solution diversity across all tasks, probably because the *default* module implemented by hybrid smaller-scale LLMs can access more diverse information sources. Our further analysis investigates the impact of intervention rate on the balance between reasoning accuracy and efficiency, showing a wide feasible range that could lead to a beneficial synergistic effect.

In summary, our main contributions are as follows:

- We propose SoT, a novel “dual process” theory-inspired framework that unleashes the synergistic potential of hybrid LLMs for efficient reasoning. The framework is model-agnostic and can be implemented with various LLMs flexibly.
- We conduct extensive experiments on six representative reasoning tasks. Empirical results demonstrate that SoT achieves state-of-the-art reasoning accuracy and solution diversity on all tasks. More importantly, SoT substantially reduces the token cost by 38.3% ~ 75.1% compared to the second accurate baseline.
- We further analyze the feasible range of intervention rates in SoT, providing useful insights for designing cost-effective LLM combinations in practice.

2 Background

In this section, we formulate some existing methods of LLM reasoning to clarify their difference with our method. We use p and s to denote the reasoning problem and solution. We denote reasoning with System 1 (intuitive) as $f_I(\cdot)$, and reasoning with System 2 (reflective) process as $f_R(\cdot)$.

Chain-of-Thought (CoT) CoT enhances LLM reasoning abilities by instructing the model to conduct step-by-step thinking: $p \rightarrow z_1, \dots, z_t \rightarrow s$, where z_1, \dots, z_t are intermediate thoughts during reasoning. In each reasoning step, thoughts are generated from a single LLM (either System 1 or System 2), which is formulated as follows:

$$z_n = f(p; \{z_m | m < n\}), f \in \{f_I, f_R\}. \quad (1)$$

Tree-of-Thoughts (ToT) ToT uses LLMs to deliberate on multiple reasoning paths and make high-quality global decisions via tree search. Formally, at the n -th reasoning step, ToT generates N thought candidates from a single LLM:

$$\{z_n^k | k = 1, 2, \dots, N\} = f(p; \{z_m | m < n\}), f \in \{f_I, f_R\}. \quad (2)$$

Then it evaluates all candidate thoughts and selects the best one as the final thought z_n at step n .

The above two well-known methods can enhance LLM reasoning abilities but are limited to using a single LLM (either System 1 or 2), suffering from either low performance or high token cost. As for most existing multi-agent debate methods [14, 19, 13], they are also focusing on reasoning with high-effort LLMs (System 2), hard to deploy on complex reasoning tasks due to the unaffordable costs. To address this issue, we propose an adaptive collaborative framework composed of hybrid LLMs, leveraging the strengths of dual reasoning processes.

3 SoT: An Efficient Reasoning Framework with the Synergy of Hybrid LLMs

The evidence suggests that intuition is the dominant basis for real-world decision-making and is often effective; however, it also shows that reliance on intuition can be dangerous and that intervention with high-effort and explicit reasoning is often required, especially when problems have novel features. — Evans et al. [9]

Motivated by the above default-interventionist theory, we introduce SoT, a framework that adaptively integrates two systems for efficient and accurate LLM reasoning. We now detail the implementations

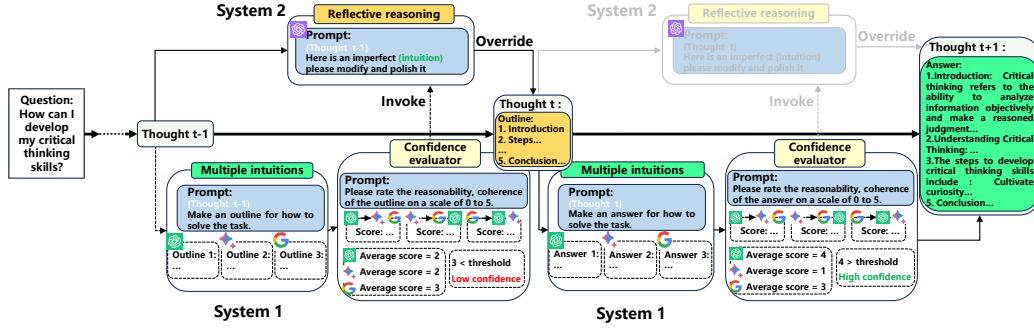

Figure 2: Overview of SoT. SoT prioritizes reasoning with default intuitions (System 1). When multiple intuitions are evaluated to be conflictual and low-confidence, SoT will intervene with reflective reasoning (invoking System 2) to override them.

of System 1 and System 2, and how our framework synergizes them for efficient reasoning. The whole framework of SoT is illustrated in Figure 2, taking an open-ended QA problem as an example. Illustrations on more tasks are shown in Appendix A.9. It’s worth noting that our framework provides a high-level design paradigm, which can have various model implementations for practice, not limited to the specific model choice.

System 1 is fast, intuitive, and largely dependent on relevant experiences, which is suitable to be implemented with smaller-scale language models that have not exhibited emergent reasoning abilities. System 1 aims to efficiently draft intuitive thoughts and advance the reasoning process forward step-by-step. Considering the existence of diverse experiential intuitions for humans, here we introduce K distinct smaller-scale LLMs (taking $K = 3$ as an example in the paper) to generate diverse intuitions, denoted as $f_{I1}(\cdot)$, $f_{I2}(\cdot)$, $f_{I3}(\cdot)$, respectively.

Given the reasoning problem p , the three LLMs first propose an initial thought respectively, then we reconcile the competition of diverse intuitive thoughts via interactions to further refine the diverse intuitions. The specific realization of System 1 is shown in Appendix A.2 and the reasoning process at step t is formulated as:

$$H_t = \text{System } 1(p_t; a_{t-1}) \quad (3)$$

where H_t is the set of proposed intuitions, p_t is the prompt of task description at the reasoning step t , a_{t-1} denotes the thoughts of the last reasoning step.

System 2 is slow, reflective, and high-effort, which is expected to produce high-quality reasoning. In the LLM reasoning pipeline, System 2 can be implemented as a reflective process where the biased intuitions are overwritten by the scaled-up language model $f_R(\cdot)$ **within a reasoning step**. Given the prompt for reflective intervention p_{ref} and the best intuition a_t at current step t , the reasoning process based on System 2 is formulated as follows:

$$a_t = \text{System } 2(p_{ref}; a_t). \quad (4)$$

Synergy of dual systems Motivated by the synergy paradigm of dual processes of human reasoning [20, 21, 22], we follow a *default-interventionist mechanism* to design the synergy framework of two competing systems. It hypothesizes the two competing systems are reconciled by utilizing System 1 to obtain low-effort default responses, which may be intervened upon with the reflection of high-effort System 2 when the confidence is low. In addition to cognitive science, there’s also evidence to support such proposals from neural imaging [23, 24, 25] and social neuroscience literature [26, 27].

Specifically, in each reasoning step, SoT prioritizes utilizing System 1 to propose multiple intuitive thoughts H , however, these intuitions are often blamed for cognitive biases when facing novel and complex problems without much relevant experience, when these intuitions show apparent conflicts, System 2 will be automatically invoked for intervention to rectify the reasoning process.

The key of the above synergy framework is a conflict-based confidence evaluator to measure the confidence of intuitions, once System 1 provides multiple intuitions $H = \{a_1, a_2, a_3\}$, the three LLMs in System 1 will conduct a cross-evaluation, where each intuition is scored in turn by each

LLM as the evaluator. Denote p_{eval} as the prompt for confidence evaluation, the score of the i -th intuition a_i is formulated as:

$$V(a_i) = \frac{\sum_{j \in \{1,2,3\}} f_{Ij}(p_{eval}; a_i)}{3} \quad (5)$$

The larger score $V(a_i)$ indicates a more coherent evaluation toward the intuition a_i and higher confidence. We then introduce a pre-defined threshold value ε , the confidence evaluator accepts the highest confidential intuition $a_k = \operatorname{argmax}_{a \in H} V(a)$ when $V(a_k) > \varepsilon$, otherwise it will reject the intuition and invoke System 2 to overwrite the thoughts. The invoking signal p is:

$$p = \begin{cases} True & V(a_k) > \varepsilon, \\ False & \text{otherwise.} \end{cases} \quad (6)$$

When the output signal is True, System 2 will intervene and override the intuitive thoughts. The working frequency of System 1 and 2 can be easily controlled with varying threshold values. To further enhance the faithfulness of the reasoning pipeline, we progressively uplift the confidence threshold with the accumulated number of System 1-based reasoning steps.

Conceptually, SoT has several benefits via the harmonious synergy of two systems: (1) *Cost efficiency*. Compared with existing advanced reasoning methods purely relying on high-cost System 2, SoT can significantly save token cost by using cost-efficient System 1 to propose intuitive thoughts. (2) *Solution diversity*. SoT introduces diverse experiential intuitions in System 1 to boost solution diversity, which is especially important for open-ended reasoning problems with huge solution space. (3) *Competitive performance*. Although SoT introduces intuitions for reasoning, the default-interventionist mechanism can timely prevent the spread of bias and ensure the quality of reasoning results. The whole process of reasoning with SoT is presented in Appendix A.3.

4 Theoretical Computation Cost Analysis

To highlight the cost efficiency of SoT, we conduct a theoretical token cost analysis. Given a reasoning task, we have the following hypothesis to give a concise analysis:

Hypothesis 1. *We suppose that every demonstration example accounts for X tokens.*

Denote $C_{Ii} = C_{Ii}^1 + C_{Ii}^2 + C_{Ii}^3$ and $C_{Io} = C_{Io}^1 + C_{Io}^2 + C_{Io}^3$ are the total input and output per-token cost for LLMs in System 1. The total cost of System 1 is:

$$C_{system1} = (K_{in}C_{Ii} + C_{Io} + 2C_{Ii} + 2C_{Io} + 2C_{Ii} + C_{Io})X, \quad (7)$$

where K_{in} denotes the number of demonstrations in the prompt. The cost of the confidence evaluation is

$$C_{eval} = (2C_{Ii} + 2C_{Io})X, \quad (8)$$

If the confidence of intuitions is low, the cost of invoking System 2 is

$$C_{invoke} = (C_{Ri} + C_{Ro})X, \quad (9)$$

where C_{Ri} and C_{Ro} are the input and output per-token cost for the LLM in System 2. By comparison, the cost of reasoning with only System 2 is:

$$C_{system2} = (K_{in}C_{Ri} + C_{Ro})X. \quad (10)$$

Denote the intervention rate as r , when $(1-r)(C_{system1} + C_{eval}) + r(C_{system1} + C_{eval} + C_{invoke}) < C_{system2}$ is satisfied, SoT is expected to effectively save token cost and the corresponding requirement of r is (taking $K_{in} = 1$ in most cases):

$$r < 1 - \frac{7C_{Ii} + 6C_{Io}}{C_{Ri} + C_{Ro}}. \quad (11)$$

In Section 5.3 we present a detailed analysis combined with specific cost statistics of used LLMs.

Table 1: Results on Game of 24 task.

Methods	Accuracy	Diversity	Token cost (\$)	TFLOPS
CoT(best of 1)	4%	1.0	0.87	5.22E+04
CoT(best of 5)	14%	1.1	1.73	1.04E+05
Self-refine	20%	1.2	24.83	1.51E+06
ToT	64%	2.1	23.37	1.40E+06
SPP	12%	1.2	29.97	1.80E+06
MAD+judge	22%	1.3	28.09	1.69E+06
<i>SoT_O</i>	<u>73%</u>	<u>2.3</u>	13.14	1.07E+06
<i>SoT_C</i>	76%	2.4	14.42	1.28E+06

Table 2: Results on Trivia Creative Writing task.

Methods	Accuracy	Diversity	Token cost (\$)	TFLOPS
CoT(best of 1)	67.1%	3.8	3.37	2.02E+05
CoT(best of 5)	73.4%	3.9	13.09	7.86E+05
Self-refine	78.2%	4.9	17.79	1.07E+06
ToT	76.8%	4.4	27.32	1.64E+06
SPP	79.9%	5.8	10.94	6.56E+05
MAD+judge	77.4%	6.1	17.00	1.02E+06
<i>SoT_O</i>	<u>82.2%</u>	6.5	2.96	1.82E+05
<i>SoT_C</i>	83.1%	<u>6.3</u>	3.41	2.38E+05

5 Experiments

5.1 Experimental Settings

Task setup. We evaluate SoT and compared methods on six complex reasoning tasks including three close-ended tasks (Game of 24 [7], Logic Grid Puzzle [15], GSM8K [16]) and three open-ended tasks (Trivia Creative Writing [17], Open-ended QA [17], Constrained Generation [18]). For each task, we use the same number of demonstration examples with original papers (one-shot in Game of 24 and zero-shot in others).

Baselines. We compare SoT with the following competitive baselines of LLM reasoning (all methods are implemented with GPT-4 unless otherwise stated, for a more fair performance comparison):

- **Chain-of-thought (CoT)** [6]: It firstly proposes to guide LLMs to think in a step-by-step manner for reasoning. For a fair comparison, we conduct multiple trials until reaching a similar token cost of our method.
- **Self-refine** [18]: It iteratively produces self-feedback and refines the results.
- **Tree-of-thoughts (ToT)** [7]: It generates multiple thought paths and searches the best solution with the heuristics method.
- **SPP** [13]: It transforms a single LLM into different personas and lets them collaborate to solve reasoning problems.
- **Multi-agent debate with judgment (MAD+judge)** [14]: It designs a multi-agent debate pipeline with judgment for addressing reasoning problems.

Metrics. We evaluate the methods for reasoning tasks from four perspectives.

- **Accuracy:** For three close-ended tasks, accuracy is measured directly by the generated answer and ground truths. For Trivia Creative Writing task, accuracy is calculated by # correct answer mentions/# trivia questions. For other open-ended tasks, we utilize FairEval [28] to test the answer quality, following prior works [17, 29].
- **Diversity:** Solution diversity of content generated by LLMs has long been a widely-discussed issue [30, 31], which is also important for reasoning tasks, especially open-ended problems with huge solution spaces. For Game of 24, we use the number of generated correct answers to measure solution diversity. For Logic Grid Puzzle and GSM8K, there’s no concept of diversity. For three open-ended tasks, we transform the prompt of FairEval to let it give a diversity score (from 1 to 10) of two answers from the same model.
- **Token cost:** It records the cost of running the method once for each task, with great attention in prior works [32, 7].
- **TFLOPS:** It reflects the computational complexity, which is estimated according to the number of parameters following [33].

SoT setup. SoT provides a model-agnostic framework, which is flexible and has various implementations. In our experiments, we try two versions of implementations, named *SoT_O* and *SoT_C*. In *SoT_O*, we implement System 1 with three popular open-source and small-scale LLMs including Mistral-7B [34], LLaMA-13B [35] and Yi-34B [36]. GPT-4 [37] is chosen to implement the intervention with System 2. In *SoT_C*, we implement System 1 with three closed-source and relatively smaller-scale LLMs including GPT-3.5 [37], PaLM2 [38] and Gemini1pro [39]. GPT-4 is chosen to implement the intervention with System 2 as before. Besides, it’s practicable to implement SoT with

Table 3: Results on Logic Grid Puzzle task.

Methods	Accuracy	Token cost (\$)	TFLOPS
CoT(best of 1)	65.8%	6.72	4.03E+05
CoT(best of 5)	67.1%	27.26	1.64E+06
Self-refine	60.6%	33.37	2.00E+06
ToT	66.1%	38.66	2.32E+06
SPP	68.3%	20.68	1.24E+06
MAD+judge	66.8%	45.00	2.70E+06
<i>SoT_O</i>	<u>69.9%</u>	11.58	7.91E+05
<i>SoT_C</i>	71.5%	12.23	8.93E+05

Table 4: Results on GSM8K task.

Methods	Accuracy	Token cost (\$)	TFLOPS
CoT (best of 1)	87.8%	9.58	5.75E+05
CoT (best of 5)	91.3%	35.78	2.15E+06
Self-refine	91.1%	23.45	1.41E+06
ToT	91.8%	25.53	1.53E+06
SPP	84.6%	63.72	3.82E+06
MAD+judge	89.3%	43.68	2.62E+06
<i>SoT_O</i>	<u>93.4%</u>	12.91	8.74E+05
<i>SoT_C</i>	94.0%	13.14	8.98E+05

Table 5: Results on Constrained Generation task (FairEval value larger than 50% means results from *SoT_O* are better).

Methods	FairEval	Diversity	Token cost (\$)	TFLOPS
<i>SoT_O</i>	6.1	7.94	5.01E+05	
v.s. CoT(best of 1)	71.4%	4.2	4.84	2.91E+05
v.s. CoT(best of 5)	63.7%	4.2	20.11	1.21E+06
v.s. Self-refine	58.4%	5.3	31.86	1.91E+06
v.s. ToT	65.2%	4.7	58.52	3.51E+06
v.s. SPP	68.6%	4.6	26.69	1.60E+06
v.s. MAD+judge	59.9%	<u>5.6</u>	36.59	2.20E+06

Table 6: Results on Open-ended Question Answer task (FairEval value larger than 50% means results from *SoT_O* are better).

Methods	FairEval	Diversity	Token cost (\$)	TFLOPS
<i>SoT_O</i>	5.5	6.23	6.23	4.48E+05
v.s. CoT(best of 1)	67.2%	3.1	2.27	1.36E+05
v.s. CoT(best of 5)	63.9%	3.3	8.72	5.23E+05
v.s. Self-refine	58.6%	4.2	15.27	9.16E+05
v.s. ToT	60.8%	3.3	19.44	1.17E+06
v.s. SPP	66.1%	3.8	8.33	5.00E+05
v.s. MAD+judge	55.2%	<u>4.7</u>	17.00	1.02E+06

other LLMs. We set the threshold value ε as 3.5 and the progressive increasing rate as 10% in the confidence evaluation for all tasks (more choices are analyzed in Section 5.3). All LLMs are accessed via APIs and we run all experiments on a CPU machine with 16GB memory.

5.2 Main Results

We present the performance comparison of SoT and baselines on six reasoning tasks in Table 1 - 6 and Appendix A.7. From the results, we have the following observations:

SoT achieves the best reasoning accuracy with significantly reduced computation cost among all methods across different tasks. Broadly, SoT outperforms all compared methods in terms of reasoning accuracy (or quality evaluation with FairEval). For three close-ended reasoning tasks (Game of 24, Logic Grid Puzzle and GSM8K), compared with the best baseline, on average SoT improves 8.6% reasoning accuracy, simultaneously saving 42.6% token costs and 30.0% TFLOPS. For three open-ended reasoning tasks (Trivia Creative Writing, Open-ended QA and Constrained Generation), compared with the best baseline, on average SoT improves 5.9% reasoning accuracy, simultaneously saving 69.1% token costs and 64.5% TFLOPS. We also provide intuitive comparisons of reasoning accuracy and solution diversity versus token costs/TFLOPS on Game of 24 and Trivia Creative Writing, as shown in Figure 3. Visualization results on other tasks can be found in Appendix A.8. Overall, SoT achieves the best trade-off between reasoning performance and cost efficiency via the effective synergy of hybrid LLMs.

SoT benefits solution diversity of reasoning tasks. Except for reasoning accuracy, we also pay attention to the solution diversity of reasoning tasks, which is especially vital for some open-ended problems. It can be found that solutions generated by SoT possess the highest diversity among all methods on four tested tasks. Specifically, for close-ended and open-ended tasks, SoT achieves 14.3% and 12.7% solution diversity improvement on average compared with the best baseline. This might be attributed to the integration of diverse experiential intuitions in System 1 and the further synergy of dual systems.

SoT achieves superior performance under various implementations. We implement SoT with two versions including both open-source and closed-source LLMs for System 1. From the results, SoT consistently outperforms baselines in terms of the trade-off between reasoning performance and costs. This demonstrates the superiority of our designed framework itself and verifies the flexibility of implementations for SoT.

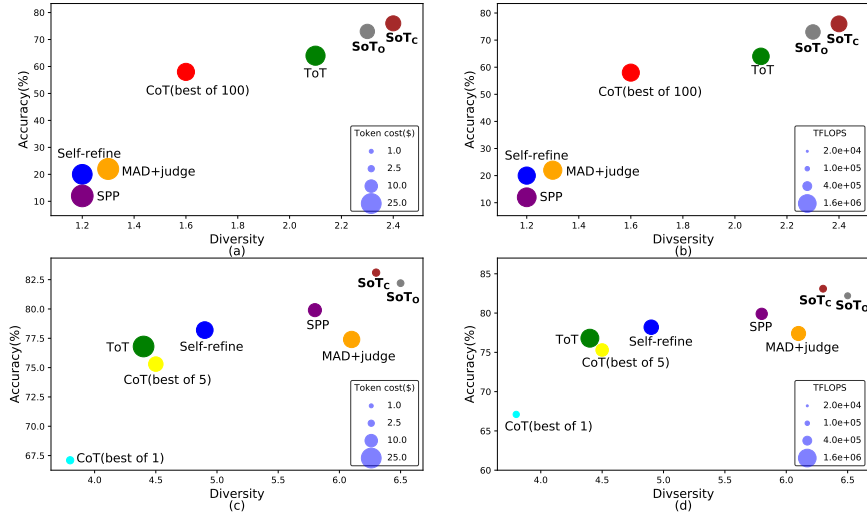

Figure 3: The reasoning accuracy, solution diversity versus token costs/TFLOPS on Game of 24 (a) (b) and Trivia Creative Writing (c) (d). SoT achieves a better performance-cost trade-off than all compared methods.

Table 7: Performance of different model choices for SoT_O on Game of 24.

Methods	Accuracy	Diversity	Token cost (\$)	TFLOPS
SoT (default)	73%	2.4	13.14	1.07E+06
SoT (3 LLaMA-13B)	61%	1.8	14.45	1.19E+06
SoT (3 Mistral-7B)	64%	2.0	13.86	1.12E+06
SoT (3 Yi-34B)	67%	2.0	14.20	1.18E+06
SoT (1 LLaMA-13B)	55%	1.5	14.92	1.26E+06
SoT (1 Mistral-7B)	60%	1.8	13.98	1.19E+06
SoT (1 Yi-34B)	58%	1.7	14.71	1.21E+06

Table 8: Performance of different model choices for SoT_C on Game of 24.

Methods	Accuracy	Diversity	Token cost (\$)	TFLOPS
SoT (default)	76%	2.4	14.42	1.28E+06
SoT (3 GPT-3.5)	70%	2.2	15.65	1.35E+06
SoT (3 PaLM2) 3 Palm2	67%	2.0	16.93	1.50E+06
SoT (3 Gemini1pro)	69%	2.1	15.34	1.28E+06
SoT (1 GPT-3.5)	67%	2.1	13.73	1.12E+05
SoT (1 PaLM2)	59%	1.9	12.88	1.02E+06
SoT (1 Gemini1pro)	62%	1.9	12.12	9.63E+05

Table 9: Performance of different model choices for SoT_O on Trivia Creative Writing.

Methods	Accuracy	Diversity	Token cost (\$)	TFLOPS
SoT (default)	82.2%	6.5	2.96	1.82E+05
SoT (3 LLaMA-13B)	77.1%	5.8	3.31	2.01E+05
SoT (3 Mistral-7B)	79.6%	5.6	3.22	1.97E+05
SoT (3 Yi-34B)	80.3%	5.7	3.56	2.13E+05
SoT (1 LLaMA-13B)	75.3%	4.4	3.69	2.16E+06
SoT (1 Mistral-7B)	76.2%	4.5	2.88	1.71E+06
SoT (1 Yi-34B)	77.8%	4.2	3.27	1.96E+06

Table 10: Performance of different model choices for SoT_C on Trivia Creative Writing.

Methods	Accuracy	Diversity	Token cost (\$)	TFLOPS
SoT (default)	83.1%	6.3	3.41	2.38E+05
SoT (3 GPT-3.5)	80.9%	5.7	3.94	2.60E+05
SoT (3 PaLM2)	78.6%	6.0	3.77	2.51E+05
SoT (3 Gemini1pro)	80.1%	5.8	3.38	2.32E+05
SoT (1 GPT-3.5)	78.4%	4.2	3.11	2.11E+05
SoT (1 PaLM2)	75.9%	4.5	3.32	2.20E+05
SoT (1 Gemini1pro)	77.3%	4.5	3.02	2.03E+05

5.3 In-depth Analysis of SoT

Study of model choices. In this part, we explore the impact of choosing different LLMs for the implementation of SoT including both open-source and closed-source LLMs. Here we show the results on Game of 24 and Trivia Creative Writing in Table 7, 8, 9, 10. For each version of SoT, we have tried implementations with each single LLM and hybrid LLMs. From the results, it can be found that utilizing hybrid LLMs to propose intuitions can benefit both accuracy and solution diversity. This might be attributed to hybrid LLMs’ ability to access more diverse information sources. Besides, utilizing more LLMs in System 1 can also harvest performance gain.

Study of the threshold value in confidence evaluation. A key design of SoT is the confidential threshold ε to adjust the workload of System 1 and System 2. In our experiments, we regulate that the confidence score ranges from 0 to 5. We then try 7 different threshold values within this interval for SoT_O and present the cost-accuracy trade-off on three tasks in Figure 4. Specifically, $\varepsilon = 0$ means intuitive thoughts from System 1 will always be accepted and SoT degrades to pure System 1, which is cost-efficient but inaccurate. $\varepsilon = 5$ means intuitive thoughts from System 1 will always be overwritten by System 2 and SoT resembles a pure System 2, which is accurate but costly. From the

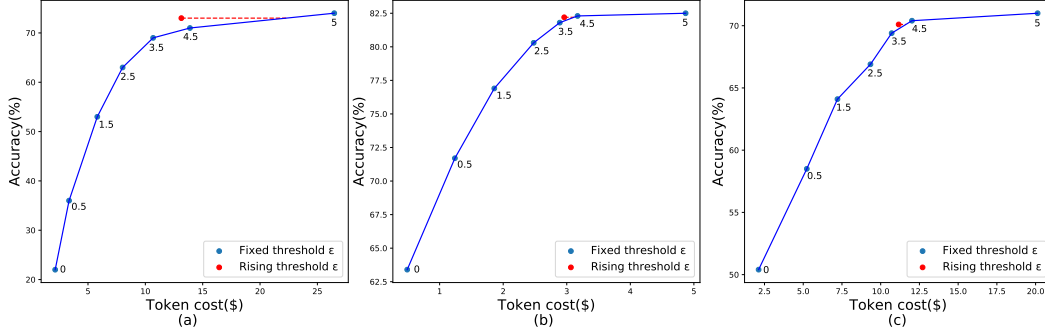

Figure 4: Reasoning cost-accuracy trade-off under different threshold value choices in SoT_O on (a) Game of 24 (b) Trivia creative writing (c) Logic Grid Puzzle. The number in the figure means the chosen threshold value.

observation that the incremental accuracy gain becomes much weaker after $\epsilon > 3.5$, for simplicity, we set $\epsilon = 3.5$ in all experiments for a better cost-accuracy trade-off. Besides, we introduce a progressive threshold-rising strategy where ϵ increases 10% at a time from 3.5 with the accumulation of intuition-based reasoning steps. This design further effectively enhances reasoning performance (shown as red dots in Figure 4) and mitigates bias propagation in the reasoning process.

Feasible intervention rate for efficient LLM synergy. In Section 4 we have a theoretical analysis of the required condition of intervention rates to save computation costs using SoT. Here we conduct a further study combined with empirical statistics to show the practical options of efficient LLM synergy. We present the empirical intervention rate of different LLM combinations on six reasoning tasks in Appendix A.6. In terms of SoT_C , the most diverse LLM combination (GPT-3.5/PaLM2/Gemini1pro + GPT-4) obtains the lowest intervention rate on the whole. By comparison, some more homogeneous synergy groups such as 3 PaLM2 + GPT-4 and 3 Gemini1pro + GPT-4 receive higher intervention rates. We calculate the upper bound of the tolerable intervention rate according to Eq.(11) and token costs shown in Appendix A.5. The required condition is $r < 61.1\%$, which is much higher than the empirical value. Similarly, for SoT_O implemented with LLaMA-13B/Mistral-7B/Yi-34B + GPT-4, it's expected to save token costs only if $r < 87.3\%$. Such estimation can be easily generalized to any LLM combination and provides a quick assessment of the feasibility of efficient LLM synergy.

6 Related Work

Reasoning with LLMs. With the blooming of LLMs, there has been plenty of work utilizing LLMs to address reasoning problems [6, 7, 40, 41, 42]. The early method is to feed standard few-shot examples in the prompt and let LLMs directly answer the target question, *i.e.*, standard IO prompting [1]. However, the resultant performance is very limited, then some more advanced prompting methods are proposed to facilitate the reasoning ability of LLMs. For example, Chain-of-thought (CoT) encourages LLMs to think in a step-by-step manner, which can activate their inherent reasoning abilities [6]. Tree-of-thoughts (ToT) further generalizes over CoT, exploring multiple different thought paths and searching in the thought tree with heuristics methods [7]. Besides, there are also some other advanced mechanisms fused to improve LLM reasoning abilities such as reflection [43] and refinement [18]. Another line of work exploring to enhance the reasoning ability of LLMs is to develop a multi-LLM collaboration system [19, 14, 13, 44, 45]. Although the above methods facilitate LLM reasoning performance, it can be found that they all try to enhance reasoning performance with various *System 2*-like deliberation mechanisms but overlook the cost-efficiency issue. Differently, our method explores the harmonious synergy of the dual process to achieve a better balance between reasoning performance and efficiency.

Cost-efficient reasoning with LLMs. Efficiency and cost are critical challenges for LLM reasoning due to the involved complex computations. To improve the speed and cost-effectiveness of LLM reasoning, there have been several approaches, such as quantization [46] and model pruning [47]. Besides, some works focused on how to utilize the paid API efficiently [48, 49]. For example, Chen et al. [48] proposed a framework that sends the query to a series of LLMs sequentially if the answers given by the prior model are considered unacceptable. However, all the above methods need to

transform the model itself or introduce external fine-tuned verifiers, bringing additional computation costs. Different from the previous model-side modification, we explore a novel path for reducing reasoning cost via diverse LLM synergy, which is training-free and general purpose.

7 Conclusion

We introduce SoT, an effective hybrid LLM synergy framework for efficient reasoning without any additional training or fine-tuning. Following the default-interventionist mechanism of human decision-making, SoT can adaptively switch between multiple experiential intuitions and reflective thoughts, thus facilitating a better trade-off between reasoning performance and computation costs. Extensive experiments on broad reasoning tasks emphasize the superiority and generalizability of our method. Compared with the best baseline, SoT can further enhance reasoning accuracy and solution diversity, simultaneously reducing the token cost by 38.3% ~ 75.1%. We hope that this work can provide a novel perspective for efficient LLM reasoning with model synergy.

References

- [1] Tom Brown, Benjamin Mann, Nick Ryder, Melanie Subbiah, Jared D Kaplan, Prafulla Dhariwal, Arvind Neelakantan, Pranav Shyam, Girish Sastry, Amanda Askell, et al. Language models are few-shot learners. *Advances in neural information processing systems*, 33:1877–1901, 2020.
- [2] Alec Radford, Karthik Narasimhan, Tim Salimans, Ilya Sutskever, et al. Improving language understanding by generative pre-training. 2018.
- [3] Alec Radford, Jeffrey Wu, Rewon Child, David Luan, Dario Amodei, Ilya Sutskever, et al. Language models are unsupervised multitask learners. *OpenAI blog*, 1(8):9, 2019.
- [4] Aakanksha Chowdhery, Sharan Narang, Jacob Devlin, Maarten Bosma, Gaurav Mishra, Adam Roberts, Paul Barham, Hyung Won Chung, Charles Sutton, Sebastian Gehrmann, et al. Palm: Scaling language modeling with pathways. *Journal of Machine Learning Research*, 24(240):1–113, 2023.
- [5] Jason Wei, Yi Tay, Rishi Bommasani, Colin Raffel, Barret Zoph, Sebastian Borgeaud, Dani Yogatama, Maarten Bosma, Denny Zhou, Donald Metzler, et al. Emergent abilities of large language models. *arXiv preprint arXiv:2206.07682*, 2022.
- [6] Jason Wei, Xuezhi Wang, Dale Schuurmans, Maarten Bosma, Fei Xia, Ed Chi, Quoc V Le, Denny Zhou, et al. Chain-of-thought prompting elicits reasoning in large language models. *Advances in Neural Information Processing Systems*, 35:24824–24837, 2022.
- [7] Shunyu Yao, Dian Yu, Jeffrey Zhao, Izhak Shafran, Thomas L Griffiths, Yuan Cao, and Karthik Narasimhan. Tree of thoughts: Deliberate problem solving with large language models. *arXiv preprint arXiv:2305.10601*, 2023.
- [8] Lianmin Zheng, Wei-Lin Chiang, Ying Sheng, Siyuan Zhuang, Zhanghao Wu, Yonghao Zhuang, Zi Lin, Zhuohan Li, Dacheng Li, Eric Xing, et al. Judging llm-as-a-judge with mt-bench and chatbot arena. *arXiv preprint arXiv:2306.05685*, 2023.
- [9] Jonathan St BT Evans. Intuition and reasoning: A dual-process perspective. *Psychological Inquiry*, 21(4):313–326, 2010.
- [10] Daniel Kahneman. *Thinking, fast and slow*. macmillan, 2011.
- [11] Pat Croskerry. Clinical cognition and diagnostic error: applications of a dual process model of reasoning. *Advances in health sciences education*, 14:27–35, 2009.
- [12] Jonathan St BT Evans. On the resolution of conflict in dual process theories of reasoning. *Thinking & Reasoning*, 13(4):321–339, 2007.
- [13] Zhenhailong Wang, Shaoguang Mao, Wenshan Wu, Tao Ge, Furu Wei, and Heng Ji. Unleashing the emergent cognitive synergy in large language models: A task-solving agent through multi-persona self-collaboration. *arXiv preprint arXiv:2307.05300*, 2023.
- [14] Tian Liang, Zhiwei He, Wenxiang Jiao, Xing Wang, Yan Wang, Rui Wang, Yujiu Yang, Zhaopeng Tu, and Shuming Shi. Encouraging divergent thinking in large language models through multi-agent debate. *arXiv preprint arXiv:2305.19118*, 2023.
- [15] Aarohi Srivastava, Abhinav Rastogi, Abhishek Rao, Abu Awal Md Shoeb, Abubakar Abid, Adam Fisch, Adam R Brown, Adam Santoro, Aditya Gupta, Adrià Garriga-Alonso, et al. Beyond the imitation game: Quantifying and extrapolating the capabilities of language models. *arXiv preprint arXiv:2206.04615*, 2022.
- [16] Karl Cobbe, Vineet Kosaraju, Mohammad Bavarian, Mark Chen, Heewoo Jun, Lukasz Kaiser, Matthias Plappert, Jerry Tworek, Jacob Hilton, Reiichiro Nakano, et al. Training verifiers to solve math word problems. *arXiv preprint arXiv:2110.14168*, 2021.
- [17] Guangyao Chen, Siwei Dong, Yu Shu, Ge Zhang, Jaward Sesay, Börje F Karlsson, Jie Fu, and Yemin Shi. Autoagents: A framework for automatic agent generation. *arXiv preprint arXiv:2309.17288*, 2023.
- [18] Aman Madaan, Niket Tandon, Prakhar Gupta, Skyler Hallinan, Luyu Gao, Sarah Wiegrefe, Uri Alon, Nouha Dziri, Shrimai Prabhunoye, Yiming Yang, et al. Self-refine: Iterative refinement with self-feedback. *arXiv preprint arXiv:2303.17651*, 2023.
- [19] Yilun Du, Shuang Li, Antonio Torralba, Joshua B Tenenbaum, and Igor Mordatch. Improving factuality and reasoning in language models through multiagent debate. *arXiv preprint arXiv:2305.14325*, 2023.

- [20] Jonathan St BT Evans. The heuristic-analytic theory of reasoning: Extension and evaluation. *Psychonomic bulletin & review*, 13(3):378–395, 2006.
- [21] Daniel Kahneman, Shane Frederick, et al. Representativeness revisited: Attribute substitution in intuitive judgment. *Heuristics and biases: The psychology of intuitive judgment*, 49(49-81):74, 2002.
- [22] Keith Stanovich. *Rationality and the reflective mind*. Oxford University Press, USA, 2011.
- [23] Wim De Neys, Oshin Vartanian, and Vinod Goel. Smarter than we think: When our brains detect that we are biased. *Psychological Science*, 19(5):483–489, 2008.
- [24] Vinod Goel and Raymond J Dolan. Explaining modulation of reasoning by belief. *Cognition*, 87(1):B11–B22, 2003.
- [25] Takeo Tsujii and Shigeru Watanabe. Neural correlates of dual-task effect on belief-bias syllogistic reasoning: a near-infrared spectroscopy study. *Brain research*, 1287:118–125, 2009.
- [26] Matthew D Lieberman. Social cognitive neuroscience: a review of core processes. *Annu. Rev. Psychol.*, 58:259–289, 2007.
- [27] Matthew D Lieberman. *What zombies can’t do: A social cognitive neuroscience approach to the irreducibility of reflective consciousness*. 2012.
- [28] Peiyi Wang, Lei Li, Liang Chen, Dawei Zhu, Binghuai Lin, Yunbo Cao, Qi Liu, Tianyu Liu, and Zhifang Sui. Large language models are not fair evaluators. *arXiv preprint arXiv:2305.17926*, 2023.
- [29] Chi-Min Chan, Weize Chen, Yusheng Su, Jianxuan Yu, Wei Xue, Shanghang Zhang, Jie Fu, and Zhiyuan Liu. Chateval: Towards better llm-based evaluators through multi-agent debate. *arXiv preprint arXiv:2308.07201*, 2023.
- [30] Robert Kirk, Ishita Mediratta, Christoforos Nalmpantis, Jelena Luketina, Eric Hambro, Edward Grefenstette, and Roberta Raileanu. Understanding the effects of rlhf on llm generalisation and diversity. *arXiv preprint arXiv:2310.06452*, 2023.
- [31] Vishakh Padmakumar and He He. Does writing with language models reduce content diversity? *arXiv preprint arXiv:2309.05196*, 2023.
- [32] Murong Yue, Jie Zhao, Min Zhang, Liang Du, and Ziyu Yao. Large language model cascades with mixture of thoughts representations for cost-efficient reasoning. *arXiv preprint arXiv:2310.03094*, 2023.
- [33] Jared Kaplan, Sam McCandlish, Tom Henighan, Tom B Brown, Benjamin Chess, Rewon Child, Scott Gray, Alec Radford, Jeffrey Wu, and Dario Amodei. Scaling laws for neural language models. *arXiv preprint arXiv:2001.08361*, 2020.
- [34] Albert Q Jiang, Alexandre Sablayrolles, Arthur Mensch, Chris Bamford, Devendra Singh Chaplot, Diego de las Casas, Florian Bressand, Gianna Lengyel, Guillaume Lample, Lucile Saulnier, et al. Mistral 7b. *arXiv preprint arXiv:2310.06825*, 2023.
- [35] Hugo Touvron, Thibaut Lavril, Gautier Izacard, Xavier Martinet, Marie-Anne Lachaux, Timothée Lacroix, Baptiste Rozière, Naman Goyal, Eric Hambro, Faisal Azhar, et al. Llama: Open and efficient foundation language models. *arXiv preprint arXiv:2302.13971*, 2023.
- [36] Alex Young, Bei Chen, Chao Li, Chengen Huang, Ge Zhang, Guanwei Zhang, Heng Li, Jiangcheng Zhu, Jianqun Chen, Jing Chang, et al. Yi: Open foundation models by 01. ai. *arXiv preprint arXiv:2403.04652*, 2024.
- [37] Josh Achiam, Steven Adler, Sandhini Agarwal, Lama Ahmad, Ilge Akkaya, Florencia Leoni Aleman, Diogo Almeida, Janko Altenschmidt, Sam Altman, Shyamal Anadkat, et al. Gpt-4 technical report. *arXiv preprint arXiv:2303.08774*, 2023.
- [38] Rohan Anil, Andrew M Dai, Orhan Firat, Melvin Johnson, Dmitry Lepikhin, Alexandre Passos, Siamak Shakeri, Emanuel Taropa, Paige Bailey, Zhifeng Chen, et al. Palm 2 technical report. *arXiv preprint arXiv:2305.10403*, 2023.
- [39] Gemini Team, Rohan Anil, Sebastian Borgeaud, Yonghui Wu, Jean-Baptiste Alayrac, Jiahui Yu, Radu Soricut, Johan Schalkwyk, Andrew M Dai, Anja Hauth, et al. Gemini: a family of highly capable multimodal models. *arXiv preprint arXiv:2312.11805*, 2023.

- [40] Xuezhi Wang, Jason Wei, Dale Schuurmans, Quoc Le, Ed Chi, Sharan Narang, Aakanksha Chowdhery, and Denny Zhou. Self-consistency improves chain of thought reasoning in language models. *arXiv preprint arXiv:2203.11171*, 2022.
- [41] Denny Zhou, Nathanael Schärli, Le Hou, Jason Wei, Nathan Scales, Xuezhi Wang, Dale Schuurmans, Claire Cui, Olivier Bousquet, Quoc V Le, et al. Least-to-most prompting enables complex reasoning in large language models. In *The Eleventh International Conference on Learning Representations*, 2022.
- [42] Yifan Zhang, Jingqin Yang, Yang Yuan, and Andrew Chi-Chih Yao. Cumulative reasoning with large language models. *arXiv preprint arXiv:2308.04371*, 2023.
- [43] Noah Shinn, Federico Cassano, Ashwin Gopinath, Karthik R Narasimhan, and Shunyu Yao. Reflexion: Language agents with verbal reinforcement learning. In *Thirty-seventh Conference on Neural Information Processing Systems*, 2023.
- [44] Justin Chih-Yao Chen, Swarnadeep Saha, and Mohit Bansal. Reconcile: Round-table conference improves reasoning via consensus among diverse llms. *arXiv preprint arXiv:2309.13007*, 2023.
- [45] Qiushi Sun, Zhangyue Yin, Xiang Li, Zhiyong Wu, Xipeng Qiu, and Lingpeng Kong. Corex: Pushing the boundaries of complex reasoning through multi-model collaboration. *arXiv preprint arXiv:2310.00280*, 2023.
- [46] Chaofan Tao, Lu Hou, Wei Zhang, Lifeng Shang, Xin Jiang, Qun Liu, Ping Luo, and Ngai Wong. Compression of generative pre-trained language models via quantization. *arXiv preprint arXiv:2203.10705*, 2022.
- [47] Mingjie Sun, Zhuang Liu, Anna Bair, and J Zico Kolter. A simple and effective pruning approach for large language models. *arXiv preprint arXiv:2306.11695*, 2023.
- [48] Lingjiao Chen, Matei Zaharia, and James Zou. Frugalgpt: How to use large language models while reducing cost and improving performance. *arXiv preprint arXiv:2305.05176*, 2023.
- [49] Marija Šakota, Maxime Peyrard, and Robert West. Fly-swat or cannon? cost-effective language model choice via meta-modeling. *arXiv preprint arXiv:2308.06077*, 2023.

A Appendix

A.1 Impact Statements

Our work provides a both cost-efficient and high-performance framework for solving reasoning problems with LLMs, which is expected to benefit broad organizations, such as the NLP research community and industrial companies. By designing such a cost-efficient framework, we empower these organizations to harness the reasoning ability of LLMs conveniently, especially for reasoning problems with high complexity. Our work not only makes financial savings but also benefits sustainability development by reducing the carbon emissions brought by extensive computation of running LLMs.

A.2 Specific Algorithm of System 1

Algorithm 1: Algorithm of System 1

Input: Reasoning task description p , thoughts of the last step a
for $k \in \{1, 2, 3\}$ **do**
 $a_k^{(1)} = f_{Ik}(p; a)$ // Generate initial thoughts
end
for $j \in \{1, 2, 3\}$ **do**
 for $k \in \{1, 2, 3\} \setminus \{j\}$ **do**
 $h_{j \rightarrow k}^{(2)} = f_{Ij}(p_{inter}; a_k^{(1)})$ // Multiple-intuition interactions
 end
end
for $k \in \{1, 2, 3\}$ **do**
 $a_k^{(3)} = f_{Ik}(p_{update}; \sum_{j \in \{1, 2, 3\} \setminus \{k\}} h_{j \rightarrow k}^{(2)})$ // Update intuitions
end
 $H = \{a_1^{(3)}, a_2^{(3)}, a_3^{(3)}\}$
return H

A.3 Specific Algorithm of SoT

Algorithm 2: Algorithm of SoT

Input: Required reasoning steps N , task description prompt in each reasoning step $\{p_0, \dots, p_N\}$
 $t = 0$ // Current reasoning step
 $a_t = None$ // Initialize current thoughts
while $t \leq N$ **do**
 $t = t + 1$
 $H_t = System\ 1(p_t; a_{t-1})$ // Propose intuitions by System 1
 $p, a_t = Confidence\ Evaluator(H_t)$ // Confidence evaluation
 if p **then**
 $a_t = System\ 2(p_{ref}; a_t)$ // Intervention with reflective System 2
 end
end
return a_t

A.4 Limitation Discussion

Currently, there are still some limitations of our method. Firstly, we have not finished running all methods several times on every task to obtain the error bars due to the huge experimental design space and we will supplement that in the later version of the paper. Secondly, our method can be combined with efficient token-level decoding techniques such as deferral rules on open-source LLMs

to further save computational costs. Thirdly, we would like to conduct experiments on more LLM combinations and consider more reasoning tasks such as MATH.

A.5 Token Prices of Used LLMs

Here we show the token prices of different LLMs we use in this work in Table 11. The statistics of GPT-3.5 and GPT-4 are from the official report of OpenAI. The statistics of Yi-34B are from the official report of 01.AI. The statistics of Gemini 1pro are from the official report of Google. The statistics of Mistral-7B are from the official report of Mistral AI. The statistics of LLaMA-13B are from Baidu online service platform. PaLM2 is cost-free when the work is done.

Table 11: Input and output token prices of used LLMs.

Model	Input /1M tokens	Output /1M tokens
GPT-3.5	\$1.5	\$2
GPT-4	\$30	\$60
Yi-34B	\$0.35	\$0.35
Gemini 1pro	\$0.5	\$1.5
Mistral-7B	\$0.25	\$0.25
LLaMA-13B	\$0.28	\$0.28
PaLM2	0	0

A.6 Empirical Average Intervention Rates

Here we show the empirical average intervention rates of different LLM combinations in System 1 on six tasks in Table 12, for measuring the practicability to maintain cost-saving by using SoT.

Table 12: Empirical average intervention rate on six reasoning tasks.

LLM combinations	Game of 24	Logic Grid Puzzle	GSM8K	Creative Writing	OpenQA	Constrained Generation
3 GPT-3.5	28%	49%	24%	51%	55%	56%
3 PaLM2	33%	55%	27%	57%	57%	61%
3 Gemini 1pro	30%	53%	26%	50%	54%	58%
GPT-3.5/PaLM2/Gemini 1pro	26%	44%	23%	42%	52%	53%
3 LLaMA-13B	39%	68%	41%	65%	67%	65%
3 Mistral-7B	36%	61%	39%	60%	61%	63%
3 Yi-34B	36%	59%	36%	61%	59%	59%
LLaMA-13B/Mistral-7B/Yi-34B	33%	54%	35%	49%	54%	57%

A.7 Supplement of Main Results

Here we supplement the main results about SoT_C on Constrained Generation and Open-ended QA tasks in Table 13 and Table 14. The results show that SoT_C outperforms all baselines, consistent with the conclusion in the main text.

A.8 Performance-cost Trade-off Analysis on More Reasoning Tasks

We conduct more performance-cost analysis on other reasoning tasks including Logic Grid Puzzle, GSM8K, Open-ended QA and Constrained Generation. The results are shown in Figure 5, 6, 7, 8, 9 and 10. Consistent with the results in the main text, SoT achieves the best performance-cost trade-off among all methods.

<https://openai.com/pricing>
<https://platform.lingyiwanwu.com/>
<https://ai.google.dev/pricing>
<https://mistral.ai/technology>
<https://console.bce.baidu.com/qianfan/ais/console/onlineService>

Table 13: Results on Constrained Generation task of SoT_C (FairEval value larger than 50% means results from SoT_C are better).

Methods	FairEval	Diversity	Token cost (\$)	TFLOPS
SoT_C		6.2	8.32	5.44E+05
v.s. CoT(best of 1)	73.0%	4.2	4.84	2.91E+05
v.s. CoT(best of 5)	66.4%	4.2	20.11	1.21E+06
v.s. Self-refine	59.2%	5.3	31.86	1.91E+06
v.s. ToT	62.9%	4.7	58.52	3.51E+06
v.s. SPP	70.7%	4.6	26.69	1.60E+06
v.s. MAD+judge	57.6%	<u>5.6</u>	36.59	2.20E+06

Table 14: Results on Open-ended Question Answer task (FairEval value larger than 50% means results from SoT_C are better).

Methods	FairEval	Diversity	Token cost (\$)	TFLOPS
SoT_C		5.2	6.77	4.72E+05
v.s. CoT(best of 1)	68.4%	3.1	2.27	1.36E+05
v.s. CoT(best of 5)	62.8%	3.3	8.72	5.23E+05
v.s. Self-refine	60.5%	4.2	15.27	9.16E+05
v.s. ToT	62.3%	3.3	19.44	1.17E+06
v.s. SPP	64.5%	3.8	8.33	5.00E+05
v.s. MAD+judge	58.1%	<u>4.7</u>	17.00	1.02E+06

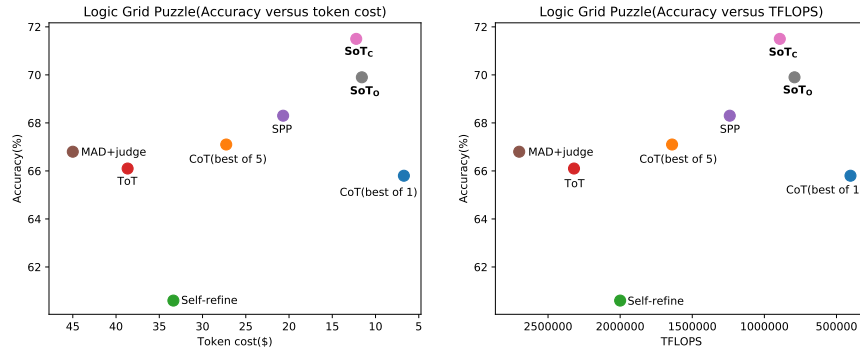

Figure 5: The reasoning accuracy versus token costs/TFLOPS on Logic Grid Puzzle task. SoT achieves a better performance-cost trade-off than all compared methods.

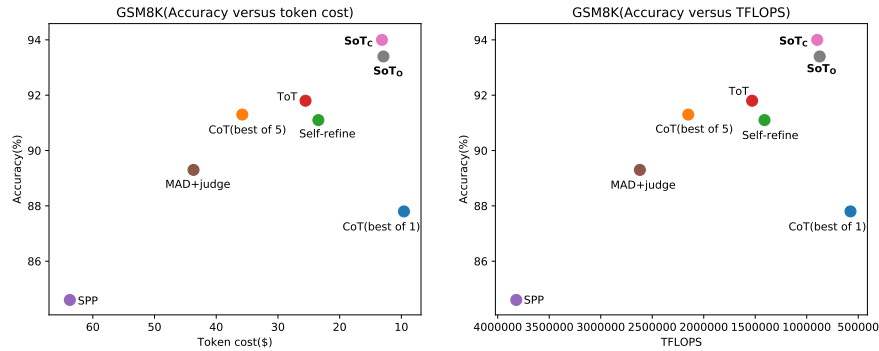

Figure 6: The reasoning accuracy versus token costs/TFLOPS on GSM8K task. SoT achieves a better performance-cost trade-off than all compared methods.

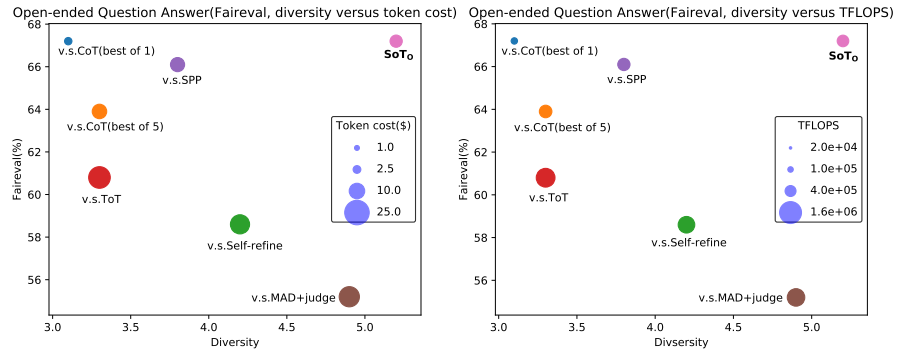

Figure 7: The reasoning accuracy, solution diversity versus token costs/TFLOPS of SoT_O and baselines on Open-ended QA task. SoT_O achieves a better performance-cost trade-off than all compared methods.

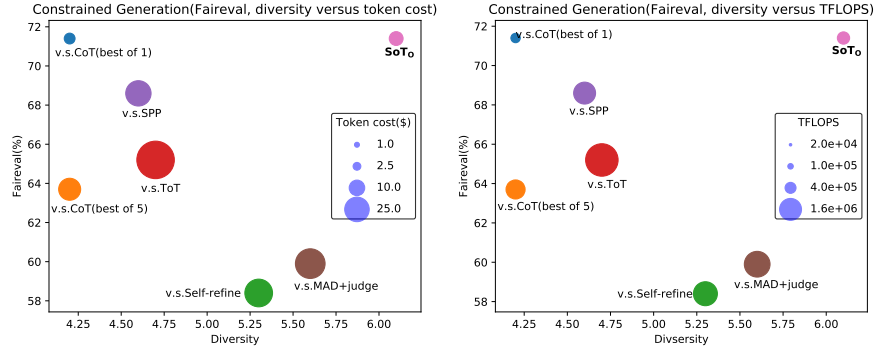

Figure 8: The reasoning accuracy, solution diversity versus token costs/TFLOPS of SoT_O and baselines on Constrained Generation task. SoT_O achieves a better performance-cost trade-off than all compared methods.

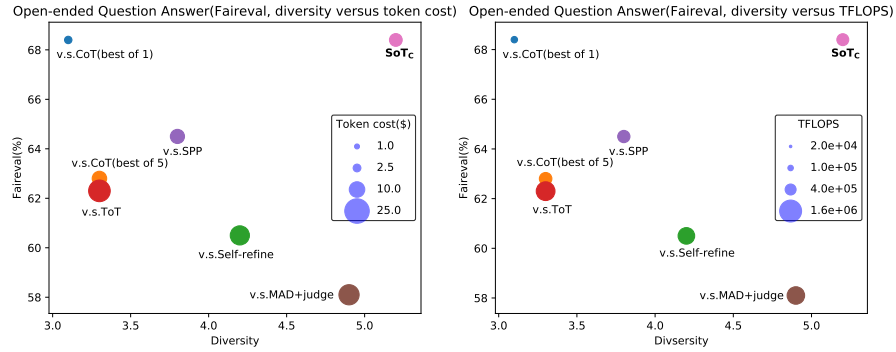

Figure 9: The reasoning accuracy, solution diversity versus token costs/TFLOPS of SoT_C and baselines on Open-ended QA task. SoT_C achieves a better performance-cost trade-off than all compared methods.

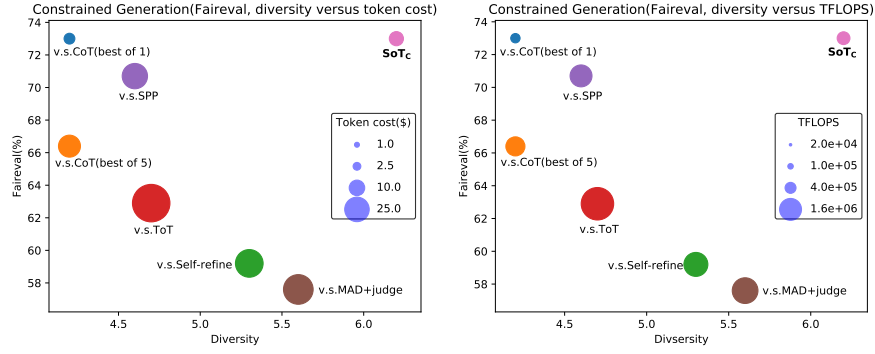

Figure 10: The reasoning accuracy, solution diversity versus token costs/TFLOPS of SoT_C and baselines on Constrained Generation task. SoT_C achieves a better performance-cost trade-off than all compared methods.

A.9 Illustrations of SoT on More Reasoning Tasks

In the main text, we illustrate SoT with an example from Open-ended QA tasks. For a better understanding of the scheme of SoT, here we present more cases from some other reasoning tasks in Figure 11, 12, 13 and 14.

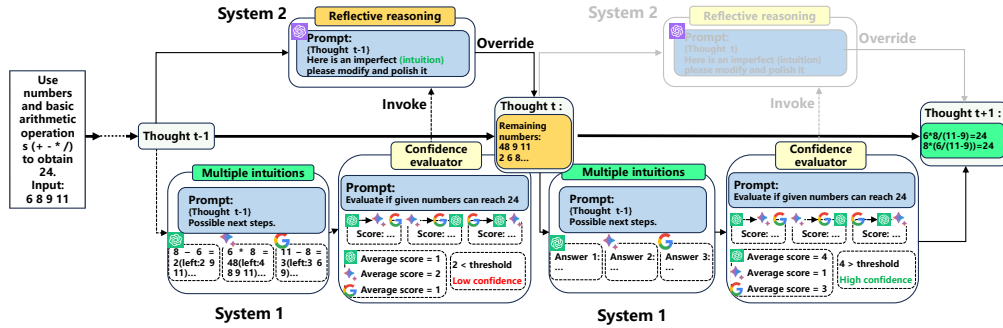

Figure 11: An illustrative example of SoT from Game of 24 Task.

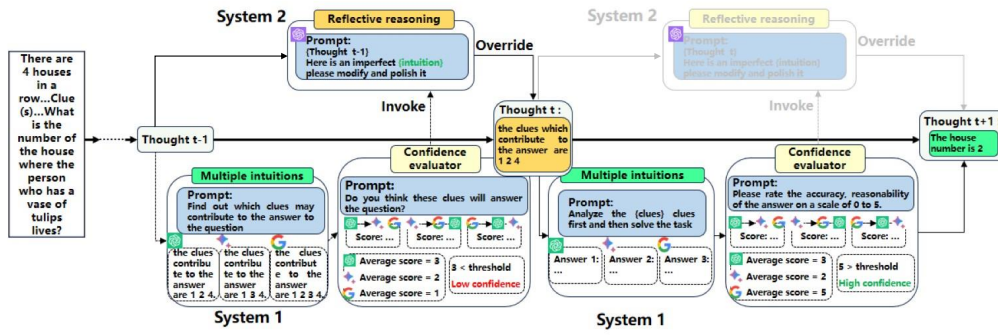

Figure 12: An illustrative example of SoT from Logic Grid Puzzle Task.

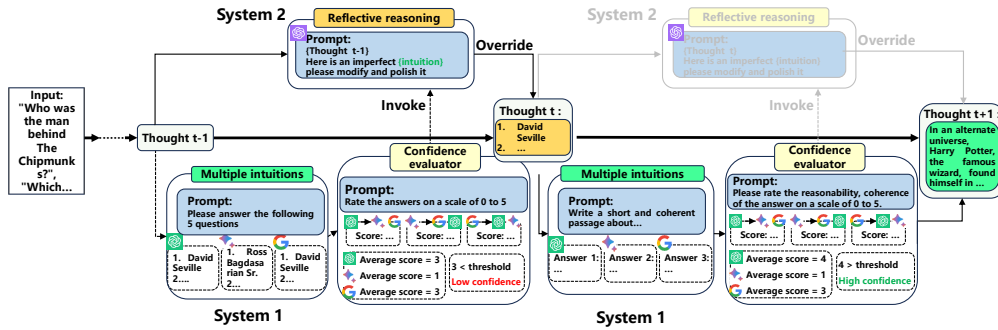

Figure 13: An illustrative example of SoT from Trivia Creative Writing Task.

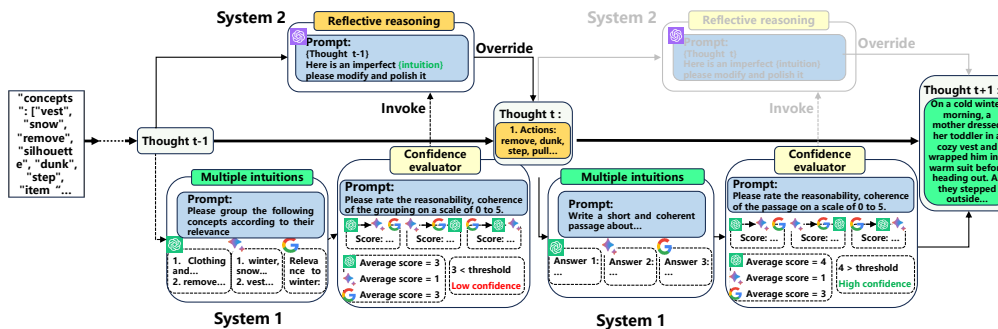

Figure 14: An illustrative example of SoT from Constrained Generation Task.