

DCRMTA: Unbiased Causal Representation for Multi-touch Attribution

Jiaming Tang¹, Jingxuan Wen², Liping Jing²

¹University of Michigan Ann Arbor

²Beijing Jiaotong University

jmtang@umich.edu, {jingxuan,lpjing}@bjtu.edu.cn

Abstract

Multi-touch attribution (MTA) currently plays a pivotal role in achieving a fair estimation of the contributions of each advertising touchpoint towards conversion behavior, deeply influencing budget allocation and advertising recommendation. Previous works attempted to eliminate the bias caused by user preferences to achieve the unbiased assumption of the conversion model. The multi-model collaboration method is not efficient, and the complete elimination of user influence also eliminates the causal effect of user features on conversion, resulting in limited performance of the conversion model. This paper redefines the causal effect of user features on conversions and proposes a novel end-to-end approach, Deep Causal Representation for MTA (DCRMTA). Our model focuses on extracting causal features between conversions and users while eliminating confounding variables. Furthermore, extensive experiments demonstrate DCRMTA's superior performance in converting prediction across varying data distributions, while also effectively attributing value across different advertising channels.

1 Introduction

Presently, online media platforms employ various marketing channels such as social networks, video media, and article push notifications to deliver advertisements for advertisers. As shown in Figure 1, users' purchasing behavior becomes increasingly complex in the Internet economy. Accurately quantifying the value of every user interaction with each advertising touchpoint (viewing, clicking, paying) can reciprocally drive the rational allocation of marketing costs of advertising channels. This implies attributing online advertising channels to the dimensions of conversion and marketing volume to efficiently harvest new user groups.

Multi-Touch Attribution (MTA), also known as Multi-Channel Attribution, can reflect the common patterns of user-channel interactions with advertisements. By learning from historical data [Berman, 2018] MTA can evaluate the contribution of each marketing touchpoint towards user conversions, reflecting user-ad interaction patterns more accurately. This guides companies in understanding what

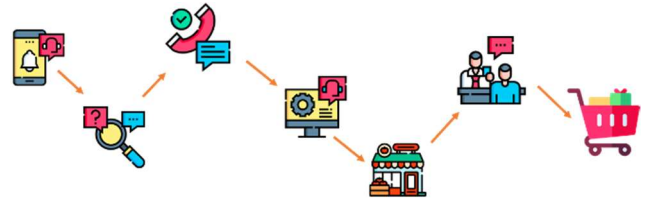

Figure 1: The complex behavior of users in online marketing.

content truly draws users to their application and enhances precision in ad placement.

Due to significant causal dependence of data features on each other, MTA faces unique challenges. As shown in Figure 2(a), user feature at time T_t can not only affect current ad channels and conversion result, but also affects the users and channels in the future time T_{t+1} , because of interactions between Internet recommender systems and user groups. Furthermore, this difficulty is exacerbated since we cannot observe both success conversion $Y_t(1)$ and failure conversion $Y_t(0)$ at the same time, we cannot get the independent causal effect without counterfactual examples [Shalit *et al.*, 2017]. Therefore, how to better represent and extract the causal relationship between users, channels and conversions is crucial to solving the MTA problem.

Deep learning's advancements have revolutionized various fields, including natural language processing, computer vision, and recommender systems, with exceptional data representation capabilities. It effectively extracts user attributes and ad touchpoint details, yet prevalent issues in MTA result in observable bottlenecks. Sparse touchpoint data and user selection bias [Chen *et al.*, 2021] in online marketing pose challenges, as well as the missing-not-at-random (MNAR) issue from unobservable simultaneous ad and non-ad touch instances. Thus, user characteristics cannot be learned unbiasedly via observational samples. These conditions disrupt the underlying assumption of conversion models—model unbiasedness—implying fairness in predicting factual or counterfactual sequences, which is infeasible in online marketing. Hence, improving model performance necessitates eliminating confounding factors to avoid biased model. To fully understand confounders in MTA, previous research [Yao *et al.*, 2022] discussed to distinguish user preference features into static attributes and dynamic records. Static attributes involves age, gender and other personal information about users. Dynamic records

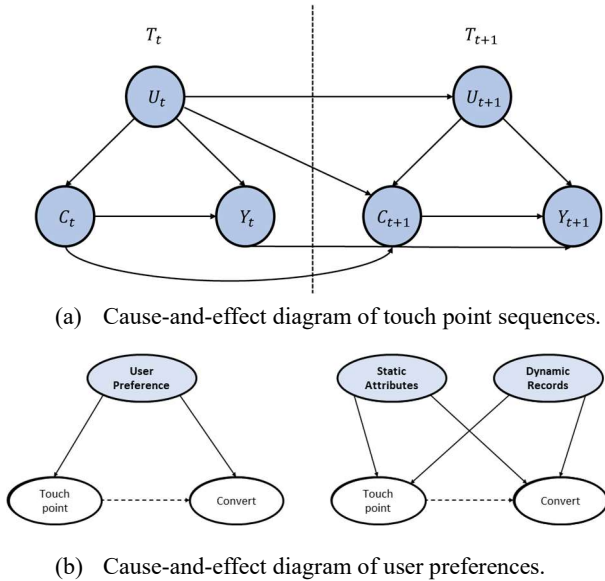

Figure 2: The causal relation in MTA. (a) shows the causal model of touch point sequences. Representing the interaction between user U_t , advertising channel C_t , and conversion result Y_t at different times T_t . (b) shows the structure of user preference. The left part is the original diagram. The right part [Yao *et al.*, 2022] splits user preference into static attributes and dynamic records.

includes historical browsing records, media usage and other information for a period of time.

Causal-based MTA presents an alternate methods better explore and understand the internal causal relationship between the diversity of user touchpoint data distribution and conversion results. Integrating the strong representation ability of deep learning with the theoretical background of the causal inference framework brings high interpretability in the attribution field. However, in practical scenarios, it is evident that the entire scope of user features cannot be learned via observational samples. The substantial influence of subjective factors on individual users' conversion behaviors stemming from variations in static attributes. Eliminating the impact of all user static features on model conversion limits the learning of user-channel interaction features.

To address these issues, we initially investigates existing MTA models based on causal inference to effectively achieve debiasing of confounding variables by exploring theories such as the Counterfactual Risk Minimization (CRM) [Swaminathan *et al.*, 2015] framework in causal inference, aiming to optimize the variance of debiasing methods. Still, raising the upper bound of the generalization error cannot effectively improve model performance which indicates that current framework is not efficient in solving the above problem because of the peculiarities of advertising.

In this paper, we propose DCRMTA, a deep causal representation learning method for the MTA problem. This method aims to mitigate the effects of user static features on conversion prediction and to identify variables causally related to conversion prediction. A user feature mining model, based on a causal attention mechanism, is utilized to deeply extract distinct static features from user-ad interaction history. DCRMTA is combined with dynamic

features obtained by a counterfactual LSTM-based model from sequential ad browsing data, enabling the learning and inference of user conversion possibilities both individually and through user-ad interactions. Finally, the model obtains the importance weight of each ad through joint game theory for cost allocation, optimizing advertising spending to the maximum extent.

We summarize our main contributions as follows: (i) As far as we know, we are the first to propose an end-to-end causal representation learning method causal MTA, which uses deep representation learning to automatically quantify complex causal effects among users' features. (ii) We propose Causal Attention Module, which implements real causal input perturbation in high-dimensional features to achieve more refined causal effect estimation. (iii) With rich and complete experiments in both synthetic and real-world Criteo data, We validate the advanced performance of our methods.

2 Related Work

The existing work can be divided into three categories based on attribution methods, including heuristic rules, data-driven MTA, counterfactual prediction.

Heuristic Rules. In the past, market researchers attempted to apply simple rules to attribute the impact of touchpoint advertising such as [Scaria *et al.*, 2014] last click, [Wang *et al.*, 2017] time decay, etc. However, such methods ignore the differences and temporal dependencies between advertising channels, and the performance of these methods is unsatisfactory because they inadequately represent the complex causal relationships.

Data-driven MTA. To overcome the above problems, researchers proposed a data-driven approach to learn attribution patterns through observation data of historical users and advertising touch sequences and conversion results. In the early stage, MTA was mainly based on probability statistics methods, and later introduced survivor analysis [Shao *et al.*, 2011] and hazard rate [Zhang *et al.*, 2014] to model the impact of advertising exposure. However, this type of method ignores the impact of user characteristics on the conversion and does not achieve modeling of temporal dependencies between channels.

Recently, with the ability of RNN models to analyze time series data, many studies have proposed MTA models based on deep neural networks to solve the above problems. Deep learning methods such as DNAMTA [Arava *et al.*, 2018] use feature encoding and neural network structure design, combined with a layered attention mechanism, to make the conversion results more competitive. DARNN [Ren *et al.*, 2018] combines the post-view and post-click attribution patterns for final conversion estimation. DeepMTA [Yang *et al.*, 2020] combines cooperative game theory with deep learning to estimate the confidence level of each touch attribution based on the predicted results of the counterfactual sequence evaluated by Shapely Value, forming a novel interpretable deep learning model.

Counterfactual Prediction. The attribution calculation of this kind of method generally relies on the counterfactual prediction results. This type of method introduces the research approach of causal inference into the MTA model, including statistical methods such as subcategories, weighting, inference, propensity score matching, etc. for

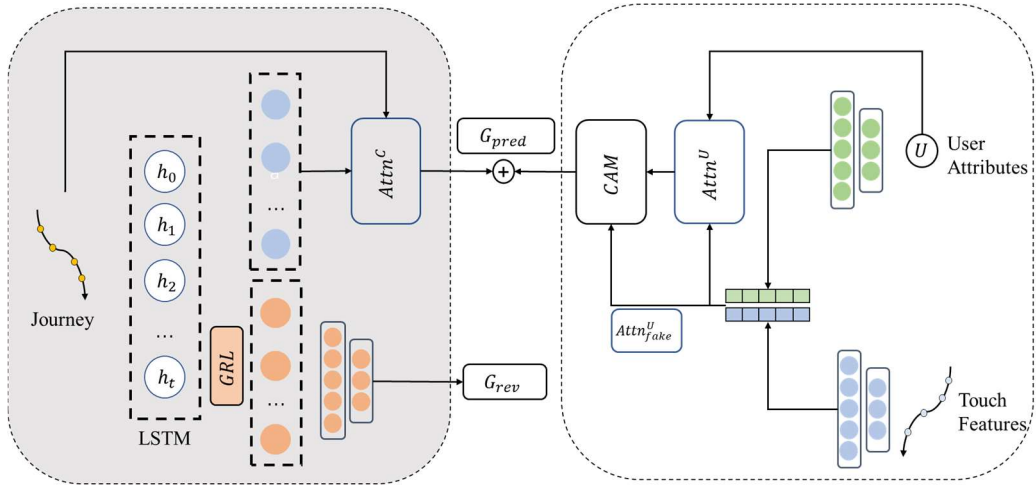

Figure 3: DCRMETA Architecture. GRL represents the gradient reversal layer, $Attn^C$ represents the attention layer of the advertising sequence, and $Attn^U$ represents the attention layer aggregated by the user and the touch feature sequence. CAM (Causal Attention Module) represents the causal attention module, which is a pseudo attention mapping map $Attn^U_{fake}$ generated through zeroing and random insertion that implements counterfactual reasoning and calculates the causal effect of attention parameters that differ from the original reasoning result. G_{pred} represents a binary classifier for conversion prediction, and G_{rev} represents an advertising channel classifier generated by gradient inversion.

unbiased causal estimation of each individual. Some scholars have also incorporated the counterfactual concept of causal inference into the cyclic neural network such as CRN [Bica *et al.*, 2020] (counterfactual recurrent neural network), establishing invariant representations of interference (treatment) for each time step, To remove the connection between historical data features and interference allocation, thus achieving correction for time-dependent mixed factors. [Kumar *et al.*, 2020] CAMTA, based on the newly proposed CRN and the layered network design concept, solves the time-varying confounding factor; CausalMTA [Yao *et al.*, 2022] which is the most-related method of our work, is based on CAMTA by reweighting touch sequences and modifying the CRN structure to adapt to the characteristics of delayed feedback in MTA tasks, thereby eliminating the impact of user static and dynamic confusion bias and training unbiased transformation prediction models.

3 Preliminary

3.1 Problem Definition.

For the MTA problem, we consider dataset \mathcal{D} as a set containing N user conversion journeys \mathcal{J}^i and corresponding user information of \mathcal{U} users. We define the touch points in i -th journey with time sequence T_i as $\{tp_t^i\}_{t=1}^{T_i}$ and ad channel set \mathcal{C} which includes k kinds of channels. Specifically, for the i -th user path (\mathcal{J}^i, y^i) in the dataset \mathcal{D} , (\mathcal{J}^i, y^i) . Note that

$$\mathcal{J}^i = (\mathcal{C}^i, \mathcal{F}^i) = \{(c_t^i, f_t^i)\}_{t=1}^T$$

where \mathcal{J}^i represents the set of advertising channel sequences and touch feature sequences, and y^i represents the final conversion result of this path.

For each touchpoint $tp_t^i = (c_t^i, f_t^i)$ contains a channel index c_t^i and a feature vector f_t^i . Among them, the channel index $c_t^i \in \mathcal{C}$ shows exposed channels and the feature vector indicates dynamic side information of this touchpoint. The label part of the dataset is a set of binary indicators $\{y^i\}^N$ that shows whether the current journey leads to a conversion.

The goal of MTA is to model sequential patterns and allocate attribution credits to all touchpoints $\{tp_t^i\}_{t=1}^{T_i}$ based on dataset \mathcal{D} . However, there are temporal dependencies and confounding biases caused by user preferences in historical observation datasets. The estimation of attribute credits poses difficult challenges. Simple deep models can learn statistical correlations between features, but cannot eliminate the catastrophic impact of confounding bias on prediction. Causal representation learning for MTA aims to learn causal patterns of users and channel features from touchpoints in each journey and estimate unbiased attribution credits $\{tp_t^i\}_{t=1}^{T_i}$ of all touchpoints.

3.2 Method Overview

As shown in Figure 3, DCRMETA is an innovative end-to-end transformation prediction model that includes three parts: causal journey representation, user causal feature extraction, and fusion conversion prediction, implementing causal feature extraction while alleviating the confounding bias from user static attributes and dynamic features.

In causal journey representation, we expect this module to extract causal relationship features in the sequential structure and channel content from the time series data of channels. Specifically, we adopted a [Yang *et al.*, 2016] hierarchical attention mechanism using different time windows to capture relevant information through local and

global attention maps, and then these features are assembled from different importance weight levels to complete the final capture of useful features for prediction. In terms of eliminating the dynamic bias, we introduce the gradient reversal layer [Bica *et al.*, 2020] to design the sequence reconstruction module and let the model learn the causal representation of data through the form of confrontation with conversion prediction.

For user causal feature extraction, we introduce causal representation learning to find the invariant features of touchpoints and users. DCRMETA first aggregates touchpoint feature vectors with user information through the an dot-product attention layer. Afterward, we create Causal Attention Modules to intervene in attention maps, thereby helping the model abandon stylized representations [Mitrovic *et al.*, 2020] that were not causal related to the conversion prediction results. After that, we fuse features of the two modules through simple matrix addition and implement the final conversion prediction through a fully connected neural network. Finally, we calculate attribute credits through Shapely Value.

4 METHODOLOGY

In this section, we first introduce our three main modules: causal journey representation, user causal feature extraction and fusion conversion prediction respectively. At last, we specify the attribution credit calculation.

4.1 Causal journey representation

To eliminate dynamic confounding variables caused by user time-varying features and recommendation mechanisms, we introduce GRL(gradient reverse layer) from CRN [Bica *et al.*, 2020] (counterfactual recurrent neural network). Here we hope to maximize the loss function of ad sequence generation while minimize the loss function of conversion prediction, so that our causal journey representation module can adversarially explore the possibility of generating different channel sequences from the same distribution while learning time series data. This part includes attention journey model and reverse generation model.

Merge vectors after word embedding encoding to obtain the input of the model:

$$\begin{aligned} \mathbf{e}_c, \mathbf{e}_f &= \text{Embedding}(\mathcal{C}, \mathcal{F}) \\ \mathbf{e}_{in} &= \text{concat}(\mathbf{e}_c, \mathbf{e}_f) \end{aligned}$$

For embedded layer input $\{\mathbf{e}_{in_1}, \mathbf{e}_{in_2}, \dots, \mathbf{e}_{in_T}\}$, each LSTM cell based on the current input e_{in_t} and the previous hidden layer state output \mathbf{h}_{t-1} to update the state of the current hidden layer \mathbf{h}_t where $\mathbf{h}_t = h(\mathbf{e}_{in}, \mathbf{h}_{t-1})$.

Attention Journey model. As shown in Figure 4, by combining the LSTM hidden layer output \mathbf{h} , we aggregate the core features of the channel sequences using the hierarchical attention mechanism. The specific implementation process is as follows:

$$\begin{aligned} \mathbf{h}_t^{attn} &= \tanh(\mathbf{W}_h \mathbf{h}_t + \mathbf{b}_h) \\ \mathbf{a}_t &= \frac{\exp((\mathbf{h}_t^{attn})^T \mathbf{e}_{in})}{\sum_i \exp((\mathbf{h}_t^{attn})^T \mathbf{e}_{in})} \\ \mathbf{m} &= \sum_t \mathbf{a}_t \mathbf{h}_t \end{aligned}$$

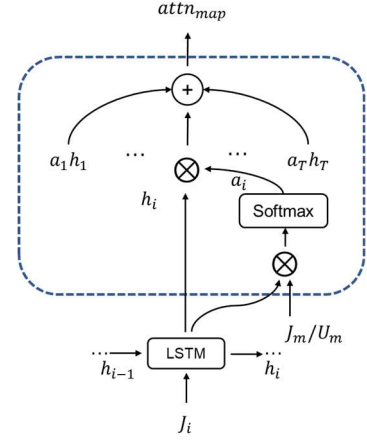

Figure 4: Hierarchical attention mechanism in DCRMETA.

where \mathbf{a}_t denotes the attention map of \mathbf{h}_t and \mathbf{m} is extracted causal features of the advertising sequence which is the input vector in the fusion conversion prediction in section 4.3.

Reverse Generation Model. In this part, we combine with gradient inversion processing of GRL and MLP classifier to implement counterfactual classification of advertising channels.

$$\begin{aligned} \mathbf{h}_t^{rev} &= \text{MLP}(\text{GRL}(\mathbf{h}_t)) \\ c_t^{rev} &= \text{softmax}(\sigma(\mathbf{h}_t^{rev})) \end{aligned}$$

where σ represents the activation function.

The loss function we get the generated advertising prediction sequence c^{rev} . We can get the sequence generation loss \mathcal{L}_{rev} simply by using CE(Cross Entropy) loss calculation,:

$$\mathcal{L}_{rev} = \alpha \sum_{i=1}^N \sum_{t=1}^{T_i} \text{CE}(c_t^{rev}, c_t) \quad (1)$$

where CE is the cross-entropy loss and α is hyperparameter.

4.2 Causal user representation

In the DCRMETA model, it is crucial to eliminate irrelevant static confounding variables while extracting user causal feature information. To comprehensively mine the user information of touch sequences, consider combining the feature information of touch sequences from advertising channels. Whether static features of users contribute to conversion prediction can be extracted from their interaction behavior information with advertisements. By introducing a [Pearl, 2000] causal input intervention, we can analyze causal relationships by directly controlling the values of variables. Some studies [Mitrovic *et al.*, 2020] have shown that the causal relationship between the data content and the target can be formally represented by causal diagram.

The following hypotheses can be put forward in conjunction with the causal diagram: (i) Data X is generated by content variable C and style variable S . (ii) Only content and not style variables are relevant to downstream tasks $f(X)$. (iii) Content and style are independent of each other.

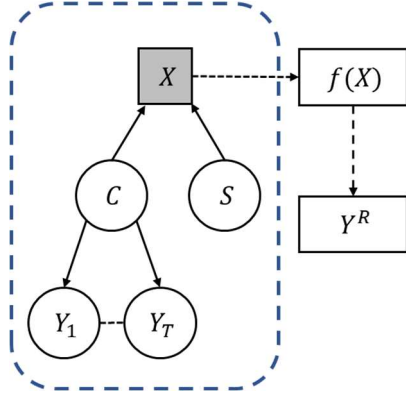

(a) Causal representation learning framework

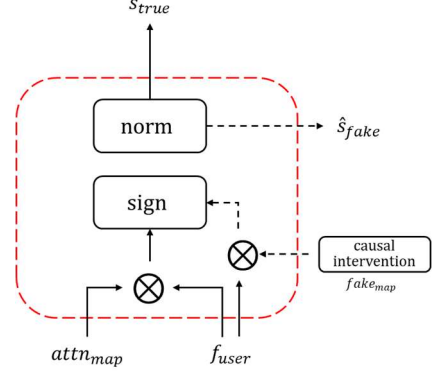

(b) CAM module structure in DCRMTA

Figure 5: Causal representation architecture and usage in DCRMTA

Figure 5(a) shows the framework of causal representation learning. Utilizing the independence of the above assumption, under the causal model of representation learning, intervention on S will not change the conditional distribution $P(Y_t|C)$, and C is called the invariant representation of Y_t under style S :

$$p^{do(S=s_i)}(Y_t|C) = p^{do(S=s_j)}(Y_t|C) \quad \forall s_i, s_j \in S \quad (2)$$

This method investigates the impact of learned latent variables, namely user touchpoint information after feature extraction, on the conversion results through the use of reverse action prediction. Then we can construct a counterfactual attention map \bar{A} to conduct counterfactual intervention $do(\bar{A})$, replacing the learned attention map and keeping the original feature map X unchanged, to obtain the counterfactual prediction $Y(do(\bar{A}, X))$ after intervention. Afterward, the invariant representation of user causal features is learned through the difference between the observed true result $Y(do(A, X))$ and the counterfactual result $Y(do(\bar{A}, X))$:

$$Y_{effect} = \mathbb{E}_{\bar{A} \sim \mathcal{N}}[Y(do(A, X)) - Y(do(\bar{A}, X))] \quad (3)$$

Causal Attention Module. In MTA, we introduce causal attention module to directly obtain invariant causal representations of user features and conversion outcomes by automatic generated fake attention maps as counterfactual intervention and compute the impact of the causal effect to conversion prediction. The module structure is shown at Figure 5(b).

For the i -th user path $(\mathcal{U}^i, \mathcal{F}^i, y^i)$ in the dataset \mathcal{D} , \mathcal{U}^i represents the user's attributes, and \mathcal{F}^i represents the sequence of touch features between advertising channels and user interactions. Note that in order to adapt to the feature dimensions of the sequence, it is first necessary to linearly increase the dimensionality of user features, so that the user feature encoding and sequence features remain in the same dimension. On this basis, the user features and advertising sequence features are merged to obtain the initial representation of the touchpoint sequence.

$$\begin{aligned} \mathbf{e}_u, \mathbf{e}_F &= \text{Embedding}(\mathcal{U}^i, \mathcal{F}) \\ \mathbf{v}_u &= \sigma(\mathbf{W}_u \cdot \mathbf{e}_u + \mathbf{b}_u) \\ \mathbf{v}_F &= \sigma(\mathbf{W}_F \cdot \mathbf{e}_F + \mathbf{b}_F) \end{aligned}$$

$$\mathbf{v}_c = \text{concat}(\mathbf{v}_u, \mathbf{v}_F)$$

where \mathbf{W}_* , \mathbf{b}_* represents the fully connected layer parameter. At the same time, the similarity between the user and advertising sequence features before the merger is calculated by matrix multiplication, and the similarity is nonlinearly activated to form attention weights.

Then, the user touchpoint sequence representation with attention mechanism is obtained by multiplying it with the original advertising feature sequence data:

$$\mathbf{w}^i = \frac{\exp((\mathbf{v}_{fi})^T \mathbf{v}_u)}{\sum_i \exp((\mathbf{v}_{fi})^T \mathbf{v}_u)}$$

$$\mathbf{v}_{attn} = (\mathbf{v}_F)^T \mathbf{w}$$

After extracting relevant features, we first calculate the final representation of the original user touchpoint sequence features and conversion mapping. The touchpoint sequence features of users after feature extraction and the initial user touchpoint sequence features. User are calculated through the attention mapping operation, and finally aggregated with the global average pooling operation ψ through the sign activation function, and normalized.

$$\mathbf{s}_i = \psi(\mathbf{v}_c, \mathbf{v}_{attn_i}) = \frac{1}{HW} \sum_{h=1}^H \sum_{w=1}^W \mathbf{v}_c^{h,w} \mathbf{v}_{attn_i}^{h,w}$$

$$\mathbf{s} = \text{norm}([\mathbf{s}_1, \mathbf{s}_2, \dots, \mathbf{s}_M])$$

where \mathbf{s}_* is the output of sign activation function.

Next, we need to construct a counterfactual user touchpoint sequence representation \mathbf{v}_{fake} , consistent with the original characterization \mathbf{v}_{attn} performs the same computational operation to obtain counterfactual representations. In practice, we use an initialization matrix with Gaussian noise.

$$\hat{\mathbf{s}}_i = \psi(\mathbf{v}_c, \mathbf{v}_{fake_i}) = \frac{1}{HW} \sum_{h=1}^H \sum_{w=1}^W \mathbf{v}_c^{h,w} \mathbf{v}_{fake_i}^{h,w}$$

$$\hat{\mathbf{s}} = \text{norm}([\hat{\mathbf{s}}_1, \hat{\mathbf{s}}_2, \dots, \hat{\mathbf{s}}_M])$$

where $\hat{\mathbf{s}}_*$ is the output of sign activation function.

4.3 Fusion conversion prediction

Combining the above two modules, we can use the fusion of causal features of advertising sequences and user causal features as inputs, and realize conversion prediction through predicted binary classifier MLP:

$$\mathbf{v}_{final} = \mathbf{s} + \mathbf{m}$$

$$\mathbf{p} = \sigma(\text{MLP}(\mathbf{v}_{final}))$$

where \mathbf{p} is the conversion prediction. Based on counterfactual representations, we can calculate balance causal effects with the the original representation to achieve counterfactual conversion prediction:

$$\hat{\mathbf{v}}_{final} = \hat{\mathbf{s}} + \mathbf{m}$$

$$\mathbf{v}_{eff} = \mathbf{v}_{final} - \hat{\mathbf{v}}_{final}$$

$$\hat{\mathbf{p}} = \sigma(\text{MLP}(\mathbf{v}_{eff}))$$

where $\hat{\mathbf{p}}$ is the counterfactual conversion prediction. The loss function of causal conversion prediction consists of two parts, *i.e.*, conversion prediction loss and causal effect loss:

$$\mathcal{L}_{cpred} = \beta \sum_{i=1}^N \text{CE}(\mathbf{p}_i, y_i) + \gamma \sum_{i=1}^N \text{CE}(\hat{\mathbf{p}}_i, y_i) \quad (4)$$

Where CE is the cross-entropy loss; β and γ are hyperparameters.

In conclusion, the loss function of DCRMETA model includes sequence reconstruction loss, and causal conversion prediction loss. That is, the comparable loss function of the model is jointly expressed as:

$$\mathcal{L}_{total} = \mathcal{L}_{cpred} + \mathcal{L}_{rev} \quad (5)$$

where α, β, γ represent the hyperparameter of the loss function scale of the control model.

4.4 Attribution Credits Calculation

For attribution credits allocation of ads, DCRMETA uses [Shapley, 1953] Shapley Values, which has been widely used.

First, we manually create counterfactual ad journeys by deleting touchpoints tp_i^j . \mathcal{S} denotes a subsequence of counterfactual ad journey $\mathcal{S} \subseteq \mathcal{J}^i \setminus \{tp_i^j\}$. We use f to define DCRMETA conversion model as a function, which gets ad journey as input and gives the conversion probability. Then the Shapley Values for a single ad channel c_t^i can be defined as:

$$SV_t^i = \sum_{\mathcal{S} \subseteq \mathcal{J}^i \setminus \{tp_i^j\}} \frac{|\mathcal{S}|! (|\mathcal{J}^i| - |\mathcal{S}| - 1)!}{|\mathcal{J}^i|!} [f(\mathcal{S} \cup \{c_t^i\}) - f(\mathcal{S})] \quad (6)$$

Afterwards, we use normalized Shapley Values to allocate attribution credits.

$$\text{attr}_t^i = \frac{(SV_t^i)^+}{\sum_{t=1}^T (SV_t^i)^+} \quad (7)$$

Where $(x)^+ = \max(x, 0)$, and attr_t^i are attribution credits for each channel of \mathcal{J}^i in time spot t .

5 Experiments

In this section, we design experiments to test the performance of DCRMETA and answer the following questions:

1. What is the performance of DCRMETA in terms of eliminating confounding bias and extracting causal features?
2. What is the performance of DCRMETA compared with SOTA MTA methods in conversion prediction?
3. How well does DCRMETA perform for economic benefits in the real-world MTA dataset?
4. What are the capabilities of the causal journey representation module and the causal user representation module?

5.1 Experimental Settings

In the experiment of the DCRMETA model, I first conducted the experiment using the Synthetic dataset* and settings proposed by CausalMTA for detecting depolarization performance.

Data Descriptions. Subsequently, consistent with the experimental setup of literature related to multi-touch attribution, I chose the Criteo-Raw [Diemert *et al.*, 2017] dataset in the MTA field. Criteo-Raw data is a dataset of online 7-day user click through rate data, which is widely used for MTA testing. The Criteo dataset consists of click events arranged in chronological order, with 26 anonymous classification fields and 13 consecutive fields as features, and 1 binary label field. The dataset in the multi-touch attribution task is based on Criteo by recoding feature fields and aggregating information using user sequences as indexes to obtain a user based advertising browsing sequence dataset. We designed a filtering algorithm based on heuristic scoring to adaptively select data that includes more features and ad channel types. Building a new Criteo-custom dataset based on real-world data Criteo Raw. This dataset has a more balanced sample and more ad channels.

Statistics	Raw	Synthetic	Criteo-custom
No. users	6,142,256	157,331	547,347
No. campaign	675	10	12
No. journeys	6,514,319	196,560	696,723
No. convert journeys	435,810	19,890	217,481
No. touchpoints	16,468,027	787,483	1,342,434

Table 1: The overview of the experiment datasets

Experiment Protocol. On the synthetic dataset, we evaluate the performance of DCRMETA in eliminating bias and extracting causal features based on the model conversion prediction. For the Criteo-custom dataset, we test the performance of DCRMETA through conversion prediction and data reply and comparing with SOTA methods. In order to show the capabilities of our modules independently, we use the synthetic dataset to conduct an ablation experiment.

Evaluation Metrics. Due to the fact that the multi-touch attribution system includes two parts: conversion prediction and attribution estimation, there are two types of evaluation indicators for each part. AUC (Area Under Curve)

and CE(Cross Entropy)-Loss are selected for evaluation. Both evaluation indicators will compare the predicted results in the set (validation set and test set) with the actual results.

For the attribution estimation module, also refer to the design method of evaluation indicators in the field of multi-touch attribution [Ren *et al.*, 2018] literature. For the cost reallocation of attribution results, the advantages and disadvantages of the multi-touch attribution system for online marketing tasks were evaluated in the Data Reply experiment using three indicators: Cost Per Action(CPA), CVR, and Conversion Number. Among them, CPA represents billing based on the cost expenditure of conversion results, which is the total conversion cost divided by the new allocation method. The lower the value, the better the system performance.

Compared Methods. In our experiments, DCRMTA was compared with six other baseline methods. **SP** [Shao *et al.*, 2011]: Simple Probability Model; **LR** [Shao *et al.*, 2011]: logistic regression model; **Nlinear**: The depth model established in this experiment has a simple structure, consisting only of 3 fully connected layers and 1 attention layer, for simple control experiments with statistical models; **DNAMTA**: A Multi-touch Attribution Model Based on Deep Recurrent Networks and Attention Mechanisms; **CausalMTA**: unbiased transformation estimation is made using sequence reweighting and causal transformation prediction, **CausalMTA-var**: variance regularization term is introduced to restrict generalization error boundary [Maurer *et al.*, 2009] for sequence reweighting loss.

In the ablation experiment, we set up two models. **DCRMTA-nU**: Remove the causal user representation module and replace it with a simple feature merging operation. **DCRMTA-nC**: Remove the CRN module without unbinding dynamic obfuscation variables.

Parameter Settings. DCRMTA has 3 hyperparameters i.e., α , β , γ . In our experiment for performance testing (Section 5.2). We find when $\alpha = 1.0$, $\beta = \gamma = 0.5$, DCRMTA has the best performance. Except for the heuristic model, the word embedding encoding part of other deep models is the same. The user attribute encoding dimension is 5, the advertising channel encoding dimension is 4, and the feature encoding dimension for each touch is 5. For the temporal model, the same 3-layer LSTM recurrent network design structure is used, with a hidden variable dimension of 64 and a drop rate of 0.2. All the experiments are conducted on a high-end server with $4 \times$ NVIDIA TITAN Xp GPUs. All the compared baselines are trained in 100 epochs and the best model is chosen to report.

5.2 Experiments on Synthetic Data

To answer **Question 1**, we process the same synthetic experiments as CausalMTA and compare the experimental results from different models on the synthetic dataset.

To further test the impact of the hyperparameter γ controlling causal effects on the transformation prediction results, we conducted a comparative experiment with hyperparameter settings. In Table 3, cf* represents the setting of hyperparameter γ to control the impact of causal effects on model training. It can be seen that the larger the parameter, the higher the AUC index of the corresponding model, and the worse the fitting effect of the model on the

Model	AUC	CE-Loss
SP	0.5001	0.3076
LR	0.5671	0.3052
Nlinear	0.5609	0.2465
DNAMTA	0.7854	0.1034
CausalMTA-nw	0.7685	0.0959
CausalMTA	0.7749	0.1125
CausalMTA-var	0.7657	0.0947
DCRMTA-nU(ours)	0.7450	0.1168
DCRMTA-nC(ours)	0.7828	0.1092
DCRMTA(ours)	0.8009	0.1154

Table 2: Results of conversion prediction

Model	AUC	CE-Loss
DCRMTA-cf0.25	0.7759	0.1147
DCRMTA-cf0.5	0.7865	0.1148
DCRMTA-cf1.0	0.8009	0.1154

Table 3: Results of causal effect experiment.

distribution of training data, CE-Loss. The reason for the analysis is that the calculation of causal effects occupies too much computational resources during backpropagation, which to some extent affects the learning of training distributions.

The comparative experimental results on the Synthetic dataset are shown in Table 2. It can be seen that our method has achieved the best performance in transforming the prediction model, surpassing the current SOTA method CausalMTA in the MTA field by about 2.6% in terms of AUC indicators, indicating that DCRMTA is effective in unbinding user confounding variables.

5.3 Experiments on Criteo Dataset

We validated the effective performance of the DCRMTA model in eliminating confounding variable bias on the Synthetic dataset. Next, to answer Question 2, we verify the conversion prediction performance of our model from the Criteo dataset derived from real online market-ing cases. The results are shown in Table 4.

Model	AUC	CE-Loss
LR	0.7021	0.2866
Nlinear	0.7733	0.1949
DNAMTA	0.7951	0.1528
CausalMTA	0.7974	0.1534
DCRMTA(ours)	0.7991	0.1489

Table 4: Results of conversion prediction.

As shown in Figure 6, we also test the main models with RMSE. The curves illustrate that for touch point data composed of users and channels with complex causal structures, our model has better convergence results.

In Table 5, the DCRMTA model performs well. In some indicators, due to only considering balanced positive and negative samples when sampling the original Criteo dataset, there are a large number of single touch sequences in the

Criterion	CPA				CVR				Convert Number			
	1/2	1/4	1/8	1/16	1/2	1/4	1/8	1/16	1/2	1/4	1/8	1/16
LR	1.082	0.9309	0.8054	0.676	0.1325	0.1052	0.0791	0.0548	27717	22002	16551	11454
Nlinear	1.289	0.9306	0.8045	0.6758	0.1320	0.1050	0.0796	0.0548	27721	21960	16657	11470
DNAMTA	1.084	0.9326	0.8073	0.6757	0.1326	0.1052	0.0789	0.0546	27732	21990	16512	11428
CausalMTA	1.081	0.9302	0.8042	0.6736	0.1326	0.1047	0.0791	0.0546	27763	21900	16546	11413
DCRMTA(ours)	1.079	0.9208	0.8069	0.6728	0.1328	0.1053	0.0798	0.0549	27779	22022	16484	11430

Table 5: Results of data reply on Criteo-custom dataset.

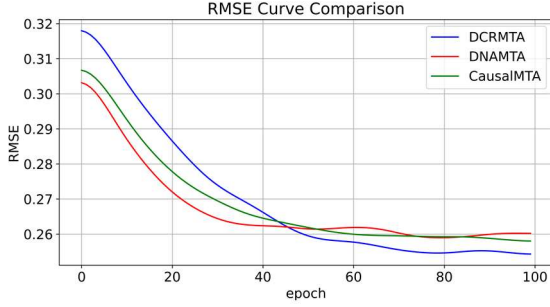

Figure 6: RMSE curves of main deep MTA models

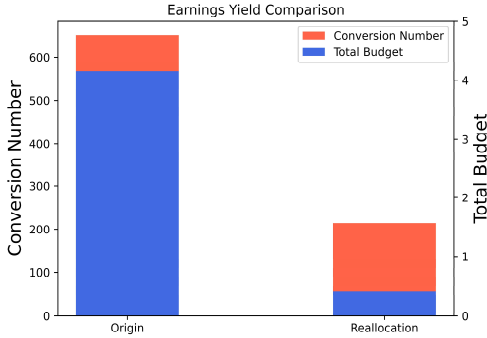

Figure 7: Yield comparison for data replay

original dataset (users only have access to one advertising channel), resulting in the temporal model not achieving relatively better results. In practical application scenarios, the number of negative samples is much greater than the number of positive samples, and there are more long sequence samples. Therefore, the next step is to consider optimizing the sampling method of the dataset to obtain a more comprehensive and reliable dataset for experimentation, and on this basis, explore the performance of the DCRMTA model on real-world datasets.

For **Question 3**, although DCRMTA model has achieved SOTA in the conversion prediction experiment, we hope that this model can produce actual economic benefits to achieve fairer and more efficient resource allocation. As shown in Figure 7, we compare the benefits before and after data replay experiment. After reallocation, we achieved 32% conversion with 10% of the original cost. We visualize the attribution results of DCRMTA which is shown in Figure 8. In 12 channel categories of Criteo-custom dataset, there are 2 channels that have 0 contribution to final conversion, and 1 channel has a 51.3% promotion effect on conversion results.

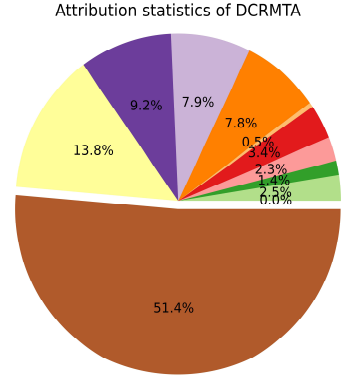

Figure 8: Attribution for Criteo-custom channels

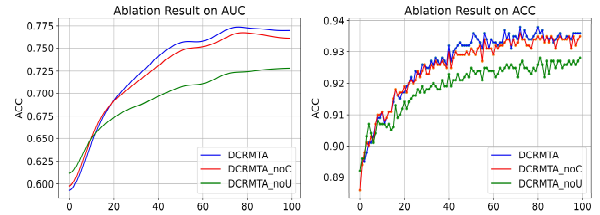

Figure 9: Comparison of ablation models from DCRMTA.

5.4 Ablation Studies

To address **Question 4**, we juxtapose DCRMTA with two ablation models, namely DCRMTA-nC and DCRMTA-nU, on a synthetic dataset. These models respectively eliminate the causal journey representation module and the causal user representation module. As depicted in Figure 9, we chart the training process. The AUCs and ACCs of DCRMTA show a marked enhancement compared to DCRMTA-nC and DCRMTA-nU. When the causal journey representation module is removed, DCRMTA's performance drops from 0.8009 to 0.7828. Meanwhile, by removing the causal user representation module, DCRMTA's performance decreases from 0.8009 to 0.7450. Upon studying the extent of these decreases, we can conclude that the improvement brought about by the Causal Attention Module in user feature extraction is more substantial than the Hierarchical Attention Mechanism in the causal journey representation. These ablation studies underscore the advancement of our model in causal feature representations.

6 Conclusion

In this paper, we identify structural limitations in existing causal MTA models, notably their neglect of the causal impacts of static user variables on conversion behavior. To overcome this, we propose DCRMTA, a novel end-to-end conversion prediction model grounded in causal representation learning. The DCRMTA leverages causal journey representation and causal user representation to derive deep causal features, further combined using a straightforward fusion operation for conversion prediction. We provide robust evidence of DCRMTA's reliability and efficiency in conversion prediction. Through extensive experiments conducted on the publicly available Criteo dataset, we demonstrate that DCRMTA outperforms all baseline models and showcases its potential effectiveness in real-world market analysis.

Acknowledgements

This work is supported by Prof. Liping Jing and Dr. Jingxuan Wen at Beijing Jiaotong University. Great thanks to my parents, mentors, and professors who have had a positive influence on this work.

References

- [Berman, 2018] Berman, R. (2018). Beyond the last touch: Attribution in online advertising. *Marketing Science*, 37(5), 771-792.
- [Shao *et al.*, 2011] Shao, X., & Li, L. (2011, August). Data-driven multi-touch attribution models. In *Proceedings of the 17th ACM SIGKDD international conference on Knowledge discovery and data mining* (pp. 258-264).
- [Zhang *et al.*, 2014] Zhang, Y., Wei, Y., & Ren, J. (2014, December). Multi-touch attribution in online advertising with survival theory. In *2014 IEEE International Conference on Data Mining* (pp. 687-696). IEEE.
- [Wang *et al.*, 2017] Wang, J., Zhang, W., & Yuan, S. (2017). Display advertising with real-time bidding (RTB) and behavioural targeting. *Foundations and Trends® in Information Retrieval*, 11(4-5), 297-435.
- [Arava *et al.*, 2018] Arava, S. K., Dong, C., Yan, Z., & Pani, A. (2018). Deep neural net with attention for multi-channel multi-touch attribution. *arXiv preprint arXiv:1809.02230*.
- [Ren *et al.*, 2018] Ren, K., Fang, Y., Zhang, W., Liu, S., Li, J., Zhang, Y., ... & Wang, J. (2018, October). Learning multi-touch conversion attribution with dual-attention mechanisms for online advertising. In *Proceedings of the 27th ACM International Conference on Information and Knowledge Management* (pp. 1433-1442).
- [Yang *et al.*, 2020] Yang, D., Dyer, K., & Wang, S. (2020). Interpretable Deep Learning Model for Online Multi-touch Attribution. *arXiv preprint arXiv:2004.00384*.
- [Singal *et al.*, 2019] Singal, R., Besbes, O., Desir, A., Goyal, V., & Iyengar, G. (2019, May). Shapley meets uniform: An axiomatic framework for attribution in online advertising. In *The World Wide Web Conference* (pp. 1713-1723).
- [Bica *et al.*, 2020] Bica, I., Alaa, A. M., Jordon, J., & van der Schaar, M. (2020). Estimating counterfactual treatment outcomes over time through adversarially balanced representations. *arXiv preprint arXiv:2002.04083*.
- [Kumar *et al.*, 2020] Kumar, S., Gupta, G., Prasad, R., Chatterjee, A., Vig, L., & Shroff, G. (2020, November). Camta: Causal attention model for multi-touch attribution. In *2020 International Conference on Data Mining Workshops (ICDMW)* (pp. 79-86). IEEE.
- [Yao *et al.*, 2022] Yao, D., Gong, C., Zhang, L., Chen, S., & Bi, J. (2022, August). CausalMTA: Eliminating the User Confounding Bias for Causal Multi-touch Attribution. In *Proceedings of the 28th ACM SIGKDD Conference on Knowledge Discovery and Data Mining* (pp. 4342-4352).
- [Shalit *et al.*, 2017] Shalit, U., Johansson, F. D., & Sontag, D. (2017, July). Estimating individual treatment effect: generalization bounds and algorithms. In *International conference on machine learning* (pp. 3076-3085). PMLR.
- [Pearl, 2000] Pearl, J. (2000). *Models, reasoning and inference*. Cambridge, UK: CambridgeUniversityPress, 19(2), 3.
- [Mitrovic *et al.*, 2020] Mitrovic, J., McWilliams, B., Walker, J., Buesing, L., & Blundell, C. (2020). Representation learning via invariant causal mechanisms. *arXiv preprint arXiv:2010.07922*.
- [Yang *et al.*, 2016] Yang, Z., Yang, D., Dyer, C., He, X., Smola, A., & Hovy, E. (2016, June). Hierarchical attention networks for document classification. In *Proceedings of the 2016 conference of the North American chapter of the association for computational linguistics: human language technologies* (pp. 1480-1489).
- [Maurer *et al.*, 2009] Maurer, A., & Pontil, M. (2009). Empirical Bernstein bounds and sample variance penalization. *arXiv preprint arXiv:0907.3740*.
- [Diemert *et al.*, 2017] Diemert, E., Meynet, J., Galland, P., & Lefortier, D. (2017). Attribution modeling increases efficiency of bidding in display advertising. In *Proceedings of the ADKDD'17* (pp. 1-6).
- [Swaminathan *et al.*, 2015] Swaminathan, A., & Joachims, T. (2015, June). Counterfactual risk minimization: Learning from logged bandit feedback. In *International Conference on Machine Learning* (pp. 814-823). PMLR.
- [Scaria *et al.*, 2014] Scaria, A. T., Philip, R. M., West, R., & Leskovec, J. (2014, February). The last click: Why users give up information network navigation. In *Proceedings of the 7th ACM international conference on Web search and data mining* (pp. 213-222).
- [Shapley, 1953] Shapley, L. S. (1953). A value for n-person games.
- [Chen *et al.*, 2021] Chen, J., Wang, X., Feng, F., & He, X. (2021, September). Bias issues and solutions in recommender system: Tutorial on the RecSys 2021. In *Proceedings of the 15th ACM Conference on Recommender Systems* (pp. 825-827).