

Rethinking Model-based, Policy-based, and Value-based Reinforcement Learning via the Lens of Representation Complexity

Guhao Feng^{*†}

Han Zhong^{*‡}

Abstract

Reinforcement Learning (RL) encompasses diverse paradigms, including model-based RL, policy-based RL, and value-based RL, each tailored to approximate the model, optimal policy, and optimal value function, respectively. This work investigates the potential hierarchy of representation complexity — the complexity of functions to be represented — among these RL paradigms. We first demonstrate that, for a broad class of Markov decision processes (MDPs), the model can be represented by constant-depth circuits with polynomial size or Multi-Layer Perceptrons (MLPs) with constant layers and polynomial hidden dimension. However, the representation of the optimal policy and optimal value proves to be NP-complete and unattainable by constant-layer MLPs with polynomial size. This demonstrates a significant representation complexity gap between model-based RL and model-free RL, which includes policy-based RL and value-based RL. To further explore the representation complexity hierarchy between policy-based RL and value-based RL, we introduce another general class of MDPs where both the model and optimal policy can be represented by constant-depth circuits with polynomial size or constant-layer MLPs with polynomial size. In contrast, representing the optimal value is P-complete and intractable via a constant-layer MLP with polynomial hidden dimension. This accentuates the intricate representation complexity associated with value-based RL compared to policy-based RL. In summary, we unveil a potential representation complexity hierarchy within RL — representing the model emerges as the easiest task, followed by the optimal policy, while representing the optimal value function presents the most intricate challenge.

1 Introduction

The past few years have witnessed the tremendous success of Reinforcement Learning (RL) (Sutton and Barto, 2018) in solving intricate real-world decision-making problems, such as Go (Silver et al., 2016) and robotics (Kober et al., 2013). These successes can be largely attributed to powerful function approximators, particularly Neural Networks (NN) (LeCun et al., 2015), and the evolution of modern RL algorithms. These algorithms can be categorized into *model-based RL*, *policy-based*

*Alphabetical order.

†School of EECS, Peking University. Email: fenguhao@stu.pku.edu.cn

‡Center for Data Science, Peking University. Email: hanzhong@stu.pku.edu.cn

RL, and *value-based RL* based on their respective objectives of approximating the underlying model, optimal policy, or optimal value function.

Despite the extensive theoretical analysis of RL algorithms in terms of statistical error (e.g., Azar et al., 2017; Jiang et al., 2017; Jin et al., 2020, 2021; Du et al., 2021; Foster et al., 2021; Zhong et al., 2022; Xu and Zeevi, 2023) and optimization error (e.g., Agarwal et al., 2021; Xiao, 2022; Cen et al., 2022; Lan, 2023) lenses, a pivotal perspective often left in the shadows is *approximation error*. Specifically, the existing literature predominantly relies on the (approximate) realizability assumption, assuming that the given function class can sufficiently capture the underlying model, optimal value function, or optimal policy. However, limited works examine the *representation complexity* in different RL paradigms — the complexity of the function class needed to represent the underlying model, optimal policy, or optimal value function. In particular, the following problem remains elusive:

Is there a representation complexity hierarchy among different RL paradigms, including model-based RL, policy-based RL, and value-based RL?

To our best knowledge, the theoretical exploration of this question is limited, with only two exceptions (Dong et al., 2020; Zhu et al., 2023). Dong et al. (2020) employs piecewise linear functions to represent both the model and value functions, utilizing the number of linear pieces as a metric for representation complexity. They construct a class of Markov Decision Processes (MDPs) where the underlying model can be represented by a constant piecewise linear function, while the optimal value function necessitates an exponential number of linear pieces for representation. This disparity underscores that the model’s representation complexity is comparatively less than that of value functions. Recently, Zhu et al. (2023) reinforced this insight through a more rigorous circuit complexity perspective. They introduce a class of MDPs wherein the model can be represented by circuits with polynomial size and constant depth, while the optimal value function cannot. However, the separation between model-based RL and value-based RL demonstrated in Zhu et al. (2023) may not be deemed significant (cf. Remark 5.6). More importantly, Dong et al. (2020); Zhu et al. (2023) do not consider policy-based RL and do not connect the representation complexity in RL with the expressive power of neural networks such as Multi-Layer Perceptron (MLP), thereby providing limited insights for modern deep RL.

1.1 Our Contributions

To address the limitations of previous works and provide a comprehensive understanding of representation complexity in RL, our paper endeavors to explore representation complexity within the realm of

♠ model-based RL ♠ policy-based RL ♠ value-based RL.

To quantify representation complexity in each category of RL, we employ a set of metrics, including

♠ computational complexity (time complexity and circuit complexity) ♠ expressiveness of MLP.

We outline our results below, further summarized in Table 1.

		Computational Complexity (time complexity and circuit complexity)	Expressiveness of Log-precision MLP (constant layers and polynomial hidden dimension)
3-SAT MDP NP MDP	Model	AC^0	✓
	Policy	NP-Complete	✗
	Value	NP-Complete	✗
CVP MDP P MDP	Model	AC^0	✓
	Policy	AC^0	✓
	Value	P-Complete	✗

Table 1: A summary of our main results. ✓ means that the function can be represented by log-precision MLP with constant layers and polynomial hidden dimension, while ✗ means that this neural network class cannot represent the function. Blue denotes low representation complexity, and red represents high representation complexity.

- Our first objective is to elucidate the representation complexity separation between model-based RL and model-free RL, encompassing both policy-based RL and value-based RL paradigms. To achieve this, we introduce two types of MDPs: 3-SAT MDPs (Definition 3.2) and a broader class referred to as NP MDPs (Definition 3.7). The intuitive construction of 3-SAT MDPs and NP MDPs involves encoding the 3-SAT problem and *any* NP-complete problem \mathcal{L} (e.g., SAT problem and knapsack problem) into the architecture of MDPs, respectively. In both cases, the representation of the model, inclusive of the reward function and transition kernel, falls within the complexity class AC^0 (cf. Section 2.3). In contrast, we demonstrate that the representation of the optimal policy and optimal value function for 3-SAT MDPs and NP MDPs is NP-complete. Our findings demonstrate a conspicuous disjunction in representation complexity between model-based RL and model-free RL. Significantly, our results not only address an open question raised by Zhu et al. (2023) but also convey a more strong message regarding the separation between model-based RL and model-free RL. See Remark 3.5 for details.
- Having unveiled the representation complexity gap between model-based RL and model-free RL, our objective is to showcase a distinct separation within the realm of model-free RL—specifically, between policy-based RL and value-based RL. To this end, we introduce two classes of MDPs: CVP MDPs (Definition 4.1) and a broader category denoted as P MDPs (Definition 4.3). CVP MDPs and P MDPs are tailored to encode the circuit value problem (CVP) and *any* P-complete problem into the construction of MDPs. In both instances, the representation complexity of the underlying model and the optimal policy is confined to the complexity class AC^0 . In contrast, the representation complexity for the optimal value function is characterized as P-complete, reflecting the inherent computational challenges associated with computing optimal values within the context of both CVP MDPs and P MDPs. Hence, we illuminate that value-based RL exhibits a more intricate representation complexity compared to policy-based RL (and model-based RL). This underscores the efficiency in representing policies (and models) while emphasizing the inherent representation complexity involved in determining optimal value functions.
- To provide more practical insights, we establish a connection between our previous findings and the realm of deep RL. Specifically, for 3-SAT MDPs and NP MDPs, we demonstrate the

effective representation of the model through a constant-layer MLP with polynomial hidden dimension, while the optimal policy and optimal value exhibit constraints in such representation. Furthermore, for the CVP MDPs and P MDPs, we illustrate that both the underlying model and optimal policy can be represented by MLPs with constant layers and polynomial hidden dimension. However, the optimal value, in contrast, faces limitations in its representation using MLPs with constant layers and polynomial hidden dimension. These results corroborate the messages conveyed through the perspective of computational complexity, contributing a novel perspective that bridges the representation complexity in RL with the expressive power of MLP.

In summary, our work contributes to a comprehensive understanding of model-based RL, policy-based RL, and value-based RL through the lens of representation complexity. Our results unveil a potential hierarchy in representation complexity among these three categories of RL paradigms — where the underlying model is the most straightforward to represent, followed by the optimal policy, and the optimal value function emerges as the most intricate to represent. This insight offers valuable guidance on determining appropriate targets for approximation, enhancing understanding of the inherent challenges in representing key elements across different RL paradigms. Moreover, our representation complexity theory is closely tied to the sample efficiency gap observed among various RL paradigms. Given that the sample complexity of RL approaches often depends on the realizable function class in use (Jiang et al., 2017; Sun et al., 2019; Du et al., 2021; Jin et al., 2021; Foster et al., 2021; Zhong et al., 2022), our results suggest that representation complexity may play a significant role in determining the diverse sample efficiency achieved by different RL algorithms. This aligns with the observed phenomenon that model-based RL typically exhibits superior sample efficiency compared to other paradigms (Jin et al., 2018; Sun et al., 2019; Tu and Recht, 2019; Janner et al., 2019; Yu et al., 2020; Zhang et al., 2023). Consequently, our work underscores the importance of considering representation complexity in the design of sample-efficient RL algorithms.

1.2 Related Works

Representation Complexity in RL. In the pursuit of achieving efficient learning in RL, most existing works (e.g., Jiang et al., 2017; Sun et al., 2019; Du et al., 2019; Jin et al., 2021; Du et al., 2021; Xie et al., 2021; Uehara and Sun, 2021; Foster et al., 2021; Zhong et al., 2022; Jin et al., 2022) adopt the (approximate) realizability assumption. This assumption allows the learner to have access to a function class that (approximately) captures the underlying model, optimal policy, or optimal value function, contingent upon the specific algorithm type in use. However, justifying the complexity of such a function class, with the capacity to represent the underlying model, optimal policy, or optimal value function, has remained largely unaddressed in these works. To the best of our knowledge, two exceptions are the works of Dong et al. (2020) and Zhu et al. (2023), which consider the representation complexity in RL. As mentioned earlier, by using the number of linear pieces of piecewise linear functions and circuit complexity as metrics, these two works reveal that the representation complexity of the optimal value function surpasses that of the underlying model. Compared with these two works, our work also demonstrates the separation between model-based RL and value-based from multiple angles, including circuit complexity, time

complexity, and the expressive power of MLP, where the last perspective seems completely new in the RL theory literature. Moreover, our result demonstrates a more significant separation between model-based RL and value-based RL. In addition, we also study the representation complexity of policy-based RL, providing a potential hierarchy among model-based RL, policy-based RL, and value-based RL from the above perspectives.

Model-based RL, Policy-based RL, and Value-based RL. In the domain of RL, there are distinct paradigms that guide the learning process: model-based RL, policy-based RL, and value-based RL, each with its unique approach. In **model-based RL**, the primary objective of the learner is to estimate the underlying model of the environment and subsequently enhance the policy based on this estimated model. Most work in tabular RL (e.g., Jaksch et al., 2010; Azar et al., 2017; Zanette and Brunskill, 2019; Zhang et al., 2021, 2023) fall within this category — they estimate the reward model and transition kernel using the empirical means and update the policy by performing the value iteration on the estimated model. Additionally, some works extend this approach to RL with linear function approximation (Ayoub et al., 2020; Zhou et al., 2021) and general function approximation (Sun et al., 2019; Foster et al., 2021; Zhong et al., 2022; Xu and Zeevi, 2023). **Policy-based RL**, in contrast, uses direct policy updates to improve the agent’s performance. Typical algorithms such as policy gradient (Sutton et al., 1999), natural policy gradient (Kakade, 2001), proximal policy optimization (Schulman et al., 2017) fall into this category. A long line of works proposes policy-based algorithms with provable convergence guarantees and sample efficiency. See e.g., Liu et al. (2019); Agarwal et al. (2020, 2021); Cai et al. (2020); Shani et al. (2020); Zhong et al. (2021); Cen et al. (2022); Xiao (2022); Wu et al. (2022); Lan (2023); Zhong and Zhang (2023); Liu et al. (2023a); Sherman et al. (2023) and references therein. In **value-based RL**, the focus shifts to the approximation of the value function, and policy updates are driven by the estimated value function. A plethora of provable value-based algorithms exists, spanning tabular RL (Jin et al., 2018), linear RL (Yang and Wang, 2019; Jin et al., 2020), and beyond (Jiang et al., 2017; Du et al., 2021; Jin et al., 2021; Zhong et al., 2022; Chen et al., 2022; Liu et al., 2023b). These works mainly explore efficient RL through the lens of sample complexity, with less consideration for representation complexity, which is the focus of our work.

1.3 Notations

We use $\mathbb{N} = \{0, 1, 2, \dots\}$ and $\mathbb{N}_+ = \{1, 2, \dots\}$ to denote the set of all natural numbers and positive integers, respectively. For any $n \in \mathbb{N}_+$, we denote $[n] = \{1, 2, \dots, n\}$, $\mathbf{0}_n = \underbrace{(0, 0, \dots, 0)}_{n \text{ times}}^\top$, and $\mathbf{1}_n = \underbrace{(1, 1, \dots, 1)}_{n \text{ times}}^\top$. We denote the distribution over a set \mathcal{X} by $\Delta(\mathcal{X})$. Let δ_x denote the Dirac measure, that is,

$$\delta_x(\mathcal{X}) = \begin{cases} 1, & x \in \mathcal{X} \\ 0, & x \notin \mathcal{X} \end{cases}.$$

2 Preliminaries

2.1 Markov Decision Process

We consider the finite-horizon Markov decision process (MDP), which is defined by a tuple $\mathcal{M} = (\mathcal{S}, \mathcal{A}, H, \mathcal{P}, r)$. Here \mathcal{S} is the state space, \mathcal{A} is the action space, H is the length of each episode, $\mathcal{P} : \mathcal{S} \times \mathcal{A} \mapsto \Delta(\mathcal{S})$ is the transition kernel, and $r : \mathcal{S} \times \mathcal{A} \mapsto [0, 1]$ is the reward function. Here we assume the reward function is deterministic and bounded in $[0, 1]$ following the convention of RL theory literature. Moreover, when the transition kernel is deterministic, say $\mathcal{P}(\cdot | s, a) = \delta_{s'}$ for some $s' \in \mathcal{S}$, we denote $\mathcal{P}(s, a) = s'$.

A policy $\pi = \{\pi_h : \mathcal{S} \mapsto \Delta(\mathcal{A})\}_{h=1}^H$ consists of H mappings from the state space to the distribution over action space. For the deterministic policy π_h satisfying $\pi_h(\cdot | s) = \delta_a$ for some $a \in \mathcal{A}$, we denote $\pi_h(s) = a$. Given a policy π , for any $(s, a) \in \mathcal{S} \times \mathcal{A}$, we define the state value function and state-action value function (Q -function) as

$$V_h^\pi(s) = \mathbb{E}_\pi \left[\sum_{h'=h}^H r_{h'}(s_{h'}, a_{h'}) \mid s_h = s \right], \quad Q_h^\pi(s, a) = \mathbb{E}_\pi \left[\sum_{h'=h}^H r_{h'}(s_{h'}, a_{h'}) \mid s_h = s, a_h = a \right],$$

where the expectation $\mathbb{E}_\pi[\cdot]$ is taken with respect to the randomness incurred by the policy π and transition kernels. There exists an optimal policy π^* achieves the highest value at all timesteps and states, i.e., $V_h^{\pi^*}(s) = \sup_\pi V_h^\pi(s)$ for any $h \in [H]$ and $s \in \mathcal{S}$. For notation simplicity, we use the shorthands $V_h^* = V_h^{\pi^*}$ and $Q_h^* = Q_h^{\pi^*}$ for any $h \in [H]$.

2.2 Function Approximation in Model-based, Policy-based, and Value-based RL

In modern reinforcement learning, we need to employ function approximation to solve complex decision-making problems. Roughly speaking, RL algorithms can be categorized into three types – model-based RL, policy-based RL, and value-based RL, depending on whether the algorithm aims to approximate the model, policy, or value. In general, policy-based RL and value-based RL can both be regarded as model-free RL, which represents a class of RL methods that do not require the estimation of a model. We assume the learner is given a function class \mathcal{F} , and we will specify the form of \mathcal{F} in model-based RL, policy-based RL, and value-based RL, respectively.

- **Model-based RL:** the learner aims to approximate the model, including the reward function and the transition kernels. Specifically, $\mathcal{F} = \{(r : \mathcal{S} \times \mathcal{A} \mapsto [0, 1], \mathcal{P} : \mathcal{S} \times \mathcal{A} \mapsto \Delta(\mathcal{S}))\}$. We also want to remark that we consider the time-homogeneous setting, where the reward function and transition kernel are independent of the timestep h . For the time-inhomogeneous setting, we can choose $\mathcal{F} = \mathcal{F}_1 \times \dots \times \mathcal{F}_H$ and let \mathcal{F}_h approximate the reward and transition at the h -th step.
- **Policy-based RL:** the learner directly approximates the optimal policy π^* . The function class \mathcal{F} takes the form $\mathcal{F} = \mathcal{F}_1 \times \dots \times \mathcal{F}_H$ with $\mathcal{F}_h \subset \{\pi_h : \mathcal{S} \mapsto \Delta(\mathcal{A})\}$ for any $h \in [H]$.
- **Value-based RL:** the learner utilizes the function class $\mathcal{F} = \mathcal{F}_1 \times \dots \times \mathcal{F}_H$ to capture the optimal value function Q^* , where $\mathcal{F}_h \subset \{Q_h : \mathcal{S} \times \mathcal{A} \mapsto [0, H]\}$ for any $h \in [H]$.

In previous literature (e.g., Jin et al., 2021; Du et al., 2021; Xie et al., 2021; Uehara and Sun, 2021; Foster et al., 2021; Zhong et al., 2022; Jin et al., 2022), a standard assumption is the *realizability* assumption – the ground truth model/optimal policy/optimal value is (approximately) realized in the given function class. Typically, a higher complexity of the function class leads to a larger sample complexity. Instead of focusing on sample complexity, as previous works have done, we are investigating how complex the function class should be by characterizing the *representation complexity* of the ground truth model, optimal policy, and optimal value function.

2.3 Computational Complexity

To rigorously describe the representation complexity, we briefly introduce some background knowledge of classical computational complexity theory, and readers are referred to Arora and Barak (2009) for a more comprehensive introduction. We first define three classes of computational complexity classes P, NP, and L.

- P is the class of languages¹ that can be recognized by a *deterministic* Turing Machine in polynomial time.
- NP is the class of languages that can be recognized by a *nondeterministic* Turing Machine in polynomial time.
- L is the class containing languages that can be recognized by a deterministic Turing machine using a logarithmic amount of space.

To facilitate the readers, we also provide the definitions of deterministic Turing Machine and nondeterministic Turing Machine in Definition A.1. To quantify the representation complexity, we also adopt the circuit complexity, a fundamental concept in theoretical computer science, to characterize it. Circuit complexity focuses on representing functions as circuits and measuring the resources, such as the number of gates, required to compute these functions. We start with defining Boolean circuits.

Definition 2.1 (Boolean Circuits). For any $m, n \in \mathbb{N}_+$, a Boolean circuit \mathbf{c} with n inputs and m outputs is a directed acyclic graph (DAG) containing n nodes with no incoming edges and m edges with no outgoing edges. All non-input nodes are called gates and are labeled with one of \wedge (logical operation AND), \vee (logical operation OR), or \neg (logical operation NOT). The value of each gate depends on its direct predecessors. For each node, its fan-in number is the number of incoming edges, and its fan-out number is its outgoing edges. The size of \mathbf{c} is the number of nodes in it, and the depth of \mathbf{c} is the maximal length of a path from an input node to the output node. Without loss of generality, we assume the output node of a circuit is the final node of the circuit.

A specific Boolean circuit can be used to simulate a function (or a computational problem) with a fixed number of input bits. When the input length varies, a sequence of Boolean circuits must

¹Following the convention of computational complexity (Arora and Barak, 2009), we may use the term “language” and “decision problem” interchangeably.

be constructed, each tailored to handle a specific input size. In this context, circuit complexity investigates how the circuit size and depth scale with the input size of a given function. We provide the definitions of circuit complexity classes AC^0 and TC^0 .

- AC^0 is the class of circuits with constant depth, unbounded fan-in number, polynomial AND and OR gates.
- TC^0 extends AC^0 by introducing an additional unbounded-fan-in majority gate MAJ, which evaluates to false when half or more arguments are false and true otherwise.

The relationship between the aforementioned five complexity classes is

$$AC^0 \subsetneq TC^0 \subset L \subset P \subset NP.$$

The question of whether the relationship $TC^0 \subset P \subset NP$ holds as a strict inclusion remains elusive in theoretical computer science. However, it is widely conjectured that $P = NP$ and $TC^0 = P$ are unlikely to be true.

3 The Separation between Model-based RL and Model-free RL

In this section, we focus on the representation complexity gap between model-based RL and model-free RL, which encompasses both policy-based RL and value-based RL. The previous work of [Dong et al. \(2020\)](#) shows that the representation complexity of model-based RL is lower than that of value-based RL, utilizing the number of pieces for a piecewise linear function as the complexity measure. However, this measure lacked rigor and general applicability to a broader range of functions. To address this limitation, [Zhu et al. \(2023\)](#) recently introduced circuit complexity as a more rigorous complexity measure. They constructed a class of MDPs where the representation complexity of the underlying model and optimal value function falls within the circuit complexity classes AC^0 and TC^0 , respectively.² However, the gap between AC^0 and TC^0 might not be considered sufficiently significant. A potential limitation arises as deep learning models, such as constant-layer MLPs, can represent functions in TC^0 , thereby capable of representing both the underlying model and optimal value function in [Zhu et al. \(2023\)](#). More details are deferred to Section 5. Therefore, a more substantial gap is needed to underscore the significance of the representation complexity difference between model-based RL and model-free RL. To this end, we construct a broad class of MDPs and prove that the underlying model can be represented by AC^0 circuits, while the representation complexity of the optimal policy and optimal value function is both NP-complete. Our results highlight a significant separation in representation complexity between model-based RL and model-free RL.

3.1 3-SAT MDP

As a warmup example to showcase the separation between model-based RL and model-free RL, we propose the 3-SAT MDPs. As implied by the name, the construction is closely linked to the

²While they only claim that the optimal value function cannot be represented by AC^0 circuits, their proof and the definition of TC^0 can imply that the optimal value function can indeed be represented by TC^0 circuits.

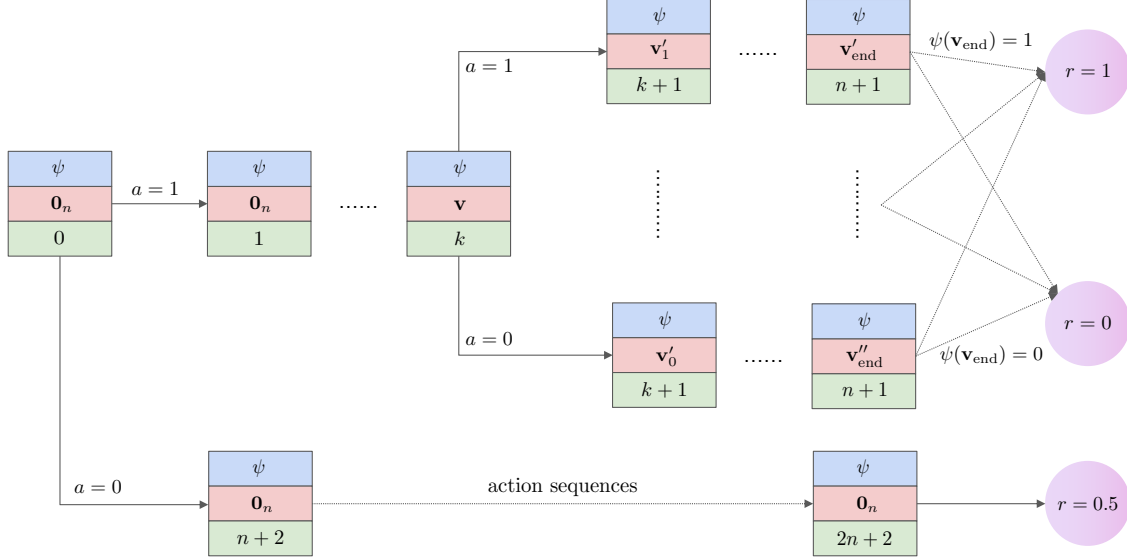

Figure 1: A visualization of 3-SAT MDPs. Here, \mathbf{v} is an n -dimensional vector, \mathbf{v}_0 and \mathbf{v}_1 are vectors obtained by replacing the k -th element of \mathbf{v} with 0 and 1, respectively. Additionally, \mathbf{v}'_{end} , and $\mathbf{v}''_{\text{end}}$ represent the assignments at the end of the episode.

well-known NP-complete problem 3-satisfiability (3-SAT). The formal definition of 3-SAT is as follows.

Definition 3.1 (3-SAT Problem). A Boolean formula ψ over variables u_1, u_2, \dots, u_n is in the 3-conjunctive normal form (3-CNF) if it takes the form of a conjunction of one or more disjunctions, each containing exactly 3 literals. Here, a literal refers to either a variable or the negation of a variable. Formally, the 3-CNF formula ψ has the following form:

$$\psi = \bigwedge_{i \in \mathcal{I}} (v_{i,1} \vee v_{i,2} \vee v_{i,3}),$$

where \mathcal{I} is the index set and $v_{i,j} = u_k$ or $v_{i,j} = \neg u_k$ for some $k \in [n]$. The 3-SAT problem is defined as follows: given a 3-CNF Boolean formula ψ , judge whether ψ is satisfiable. Here, “satisfiable” means that there exists an assignment of variables such that the formula ψ evaluates to 1.

Given the definition of 3-SAT problem, we are ready to present the detailed construction of 3-SAT MDPs.

Definition 3.2 (3-SAT MDP). For any $n \in \mathbb{N}_+$, let $\mathcal{V} = \{u_1, \neg u_1, \dots, u_n, \neg u_n\}$ be the set of literals. An n -dimensional 3-SAT MDP $(\mathcal{S}, \mathcal{A}, H, \mathcal{P}, r)$ is defined as follows. The state space \mathcal{S} is defined by $\mathcal{S} = \mathcal{V}^{3n} \times \{0, 1\}^n \times (\{0\} \cup [2n+2])$, where each state s can be denoted as $s = (\psi, \mathbf{v}, k)$. In this representation, ψ is a 3-CNF formula consisting of n clauses and represented by its $3n$ literals, $\mathbf{v} \in \{0, 1\}^n$ can be viewed as an assignment of the n variables and k is an integer recording the number of actions performed. The action space is $\mathcal{A} = \{0, 1\}$ and the planning horizon is $H = n+2$.

Given a state $s = (\psi, \mathbf{v}, k)$, for any $a \in \mathcal{A}$, the reward $r(s, a)$ is defined by:

$$r(s, a) = \begin{cases} 1 & \text{If } \mathbf{v} \text{ is a satisfiable assignment of } \psi \text{ and } k = n + 1, \\ 0.5 & \text{If } k = 2n + 2, \\ 0 & \text{Otherwise.} \end{cases} \quad (3.1)$$

Moreover, the transition kernel is deterministic and takes the following form:

$$\mathcal{P}((\psi, \mathbf{v}, k), a) = \begin{cases} (\psi, \mathbf{v}, n + 2) & \text{If } a = k = 0, \\ (\psi, \mathbf{v}, 1) & \text{If } a = 1 \text{ and } k = 0, \\ (\psi, \mathbf{v}', k + 1) & \text{If } k \in [n] \\ (\psi, \mathbf{v}, k + 1) & \text{If } k > n. \end{cases} \quad (3.2)$$

where \mathbf{v}' is obtained from \mathbf{v} by setting the k -th bit as a and leaving other bits unchanged, i.e., $\mathbf{v}'[k] = a$ and $\mathbf{v}'[k'] = \mathbf{v}[k']$ for $k' \neq k$. The initial state takes form $(\psi, \mathbf{0}_n, 0)$ for any length- n 3-CNF formula ψ .

The visualization of 3-SAT MDPs is given in Figure 1. We assert that our proposed 3-SAT model is relevant to real-world problems. In the state $s = (\psi, \mathbf{v}, k)$, ψ characterizes intrinsic environmental factors that remain unchanged by the agent, while \mathbf{v} and k represent elements subject to the agent’s influence. Notably, the agent is capable of changing $\mathbf{0}_n$ to any n -bits binary string within the episode. Using autonomous driving as an example, ψ could denote fixed factors like road conditions and weather, while \mathbf{v} and k may represent aspects of the car that the agent can control. While states and actions in practical scenarios might be continuous, they are eventually converted to binary strings in computer storage due to bounded precision. Regarding the reward structure, the agent only receives rewards at the end of the episode, reflecting the goal-conditioned RL setting and the sparse reward setting, which capture many real-world problems. Intuitively, the agent earns a reward of 1 if ψ is satisfiable, and the agent transforms $\mathbf{0}_n$ into a variable assignment that makes ψ equal to 1 through a sequence of actions. The agent receives a reward of 0.5 if, at the first step, it determines that ψ is unsatisfiable and chooses to “give up”. Here, we refer to taking action 0 at the first step as “give up” since this action at the outset signifies that the agent foregoes the opportunity to achieve the highest reward of 1. In all other cases, the agent receives a reward of 0. Using the example of autonomous driving, if the car successfully reaches its (reachable) destination, it obtains the highest reward. If the destination is deemed unreachable and the car chooses to give up at the outset, it receives a medium reward. This decision is considered a better choice than investing significant resources in attempting to reach an unattainable destination, which would result in the lowest reward.

Theorem 3.3 (Representation complexity of 3-SAT MDP). Let \mathcal{M}_n be the n -dimensional 3-SAT MDP in Definition 3.2. The transition kernel \mathcal{P} and the reward function r of \mathcal{M}_n can be computed by circuits with polynomial size (in n) and constant depth, falling within the circuit complexity class AC^0 . However, computing the optimal value function Q_1^* and the optimal policy π_1^* of \mathcal{M}_n are both NP-complete under the polynomial time reduction.

Proof of Theorem 3.3. See Appendix B.1 for a detailed proof. □

Theorem 3.3 states that the representation complexity of the underlying model is in AC^0 , whereas the representation complexity of optimal value function and optimal policy is NP-complete. This demonstrates the significant separation of the representation complexity of model-based RL and that of model-free RL. To illustrate our theory more, we make the following remarks.

Remark 3.4. Although Theorem 3.3 only shows that Q_1^* is hard to represent, our proof also implies that V_1^* is hard to represent. Moreover, we can extend our results to the more general case, say $\{Q_h^*\}_{h \in [\lfloor \frac{n}{2} \rfloor]}$ are NP-complete, by introducing additional irrelevant steps. Notably, one cannot anticipate Q_h^* to be hard to represent for any $h \in [H]$ since Q_H reduces to the one-step reward function r . This aligns with our intuition that the multi-step correlation is pivotal in rendering the optimal value functions in “early steps” challenge to represent. Moreover, although we only show that π_1^* is hard to represent in our proof, the result can be extended to step h where $2 \leq h \leq H$, as π_1^* also serves as an optimal policy at step h . Finally, it is essential to emphasize that, since our objective is to show that $Q^* = \{Q_h^*\}_{h=1}^H$ and $\pi^* = \{\pi_h^*\}_{h=1}^H$ have high representation complexity, it suffices to demonstrate that Q_1^* and π_1^* are hard to represent.

Remark 3.5. The recent work of Zhu et al. (2023) raises an open problem regarding the existence of a class of MDPs whose underlying model can be represented by AC^k circuits while the optimal value function cannot. Here, AC^k is a complexity class satisfying $AC^0 \subset AC^k \subset P \subset NP$. Therefore, our results not only address this open problem by revealing a more substantial gap in representation complexity between model-based RL and model-free RL but also surpass the expected resolution conjectured in Zhu et al. (2023).

Remark 3.6 (Extension to the Stochastic Setting). Note that the transition kernel of 3-SAT MDPs in Definition 3.2 is deterministic, indicating that the next state is entirely determined by the current state and the chosen action. In fact, our results in the deterministic setting pave the way for an extension to the stochastic case. In Appendix E, we introduce slight modifications to the 3-SAT construction, proposing the stochastic 3-SAT MDP. For stochastic 3-SAT MDPs, we establish that the representation complexity persists as a significant distinction between model-based RL and model-free RL.

3.2 NP MDP: A Broader Class of MDPs

In this section, we extend the results on representation complexity separation between model-based RL and model-free RL for 3-SAT MDPs, which heavily rely on the inherent problem structure of 3-SAT problems. This extension introduces the concept of NP MDP—a more inclusive category of MDPs. Specifically, for any NP-complete language \mathcal{L} , we can construct a corresponding NP MDP that encodes \mathcal{L} into the structure of MDPs. Importantly, this broader class of MDPs yields the same outcomes as 3-SAT MDPs. In other words, in the context of NP MDP, the underlying model can be computed by circuits in AC^0 , while the computation of both the optimal value function and optimal policy remains NP-complete. The detailed definition of NP MDP is provided below.

Definition 3.7 (NP MDP). An NP MDP is defined concerning a language $\mathcal{L} \in \text{NP}$. Let M be a nondeterministic Turing Machine recognizing \mathcal{L} in at most $P(n)$ steps, where n is the length of the input string and $P(n)$ is a polynomial. Let M have valid configurations denoted by \mathcal{C}_n , and let each configuration $c = (s_M, \mathbf{t}, l) \in \mathcal{C}_n$ encompass the state of the Turing Machine s_M , the contents of the tape \mathbf{t} , and the pointer on the tape l , requiring $O(P(n))$ bits for representation. Then an n -dimensional NP MDP is defined as follows. The state space \mathcal{S} is $\mathcal{C}_n \times (\{0\} \cup [2P(n) + 2])$, and each $s = (c, k) \in \mathcal{S}$ consists of a valid configuration $c = (s_M, \mathbf{t}, l)$ and a index $k \in \{0\} \cup [2P(n) + 2]$ recording the number of steps M has executed. The action space is $\mathcal{A} = \{0, 1\}$ and the planning horizon is $H = P(n) + 2$. Given state $s = (c, k) = (s_M, \mathbf{t}, l, k)$ and action a , the reward function $r(s, a)$ is defined by:

$$r(s, a) = \begin{cases} 1 & \text{If } s_M = s_{\text{accept}} \text{ and } k = P(n) + 1, \\ 0.5 & \text{If } k = 2P(n) + 2, \\ 0 & \text{Otherwise,} \end{cases} \quad (3.3)$$

where s_{accept} is the accept state of Turing Machine M . Moreover, the transition kernel is deterministic and can be defined as follows:

$$\mathcal{P}((c, k), a) = \begin{cases} (c, P(n) + 2) & \text{If } a = k = 0, \\ (c, 1) & \text{If } a = 1 \text{ and } k = 0, \\ (c', k + 1) & \text{If } k \in [P(n)] \\ (c, k + 1) & \text{If } k > P(n). \end{cases} \quad (3.4)$$

where c' is the configuration obtained from c by selecting the branch a at the current step and executing the Turing Machine M for one step. Let $\mathbf{x}_{\text{input}}$ be an input string of length n . We can construct the initial configuration c_0 of the Turing Machine M on the input $\mathbf{x}_{\text{input}}$ by copying the input string onto the tape, setting the pointer to the initial location, and designating the state of the Turing Machine as the initial state. Then the initial state of NP MDP is defined as $(c_0, 0)$.

The definition of NP MDP in Definition 3.7 generalizes that of the 3-SAT MDP in Definition 3.2 by incorporating the nondeterministic Turing Machine, a fundamental computational mode. The configuration c and the accept state s_{accept} in NP MDPs mirror the formula-assignment pair (ψ, \mathbf{v}) and the scenario that $\psi(\mathbf{v}) = 1$ in 3-SAT MDP, respectively. To the best of our knowledge, NP MDP is the first class of MDPs defined in the context of (non-deterministic) Turing Machine and can encode *any* NP-complete problem in an MDP structure. This represents a significant advancement compared to the Majority MDP in Zhu et al. (2023) and the 3-SAT MDP in Definition 3.2, both of which rely on specific computational problems such as the Majority function and the 3-SAT problem. The following theorem provides the theoretical guarantee for the NP-complete MDP.

Theorem 3.8 (Representation complexity of NP MDP). Consider any NP-complete language \mathcal{L} alongside its corresponding n -dimensional NP MDP \mathcal{M}_n , as defined in Definition 3.7. The transition kernel \mathcal{P} and the reward function r of \mathcal{M}_n can be computed by circuits with polynomial size (in n) and constant depth, belonging to the complexity class AC^0 . In contrast, the problems of computing

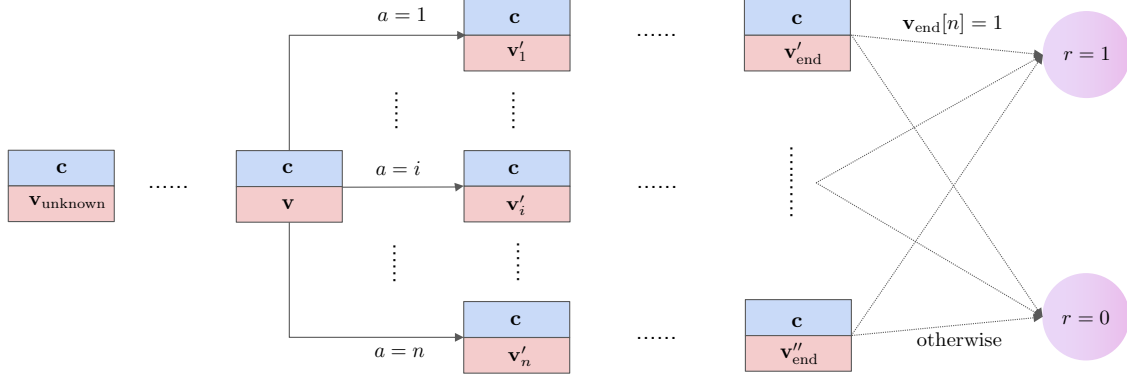

Figure 2: A visualization of CVP MDPs. Here, $\mathbf{v}_{\text{unknown}}$, which contains n **Unknown** values, is the initial value vector. For any state s including a circuit \mathbf{c} and a value vector \mathbf{v} , choosing the action i , the environment transits to $(\mathbf{c}, \mathbf{v}'_i)$. Moreover, \mathbf{v}_{end} , \mathbf{v}'_{end} , and $\mathbf{v}''_{\text{end}}$ are value vectors at the end of the episode.

the optimal value function Q_1^* and the optimal policy π_1^* of \mathcal{M}_n are both NP-complete under the polynomial time reduction.

Proof of Theorem 3.8. See Appendix B.2 for a detailed proof. \square

Theorem 3.8 demonstrates that a substantial representation complexity gap between model-based RL (AC^0) and model-free RL (NP-complete) persists in NP MDPs. Consequently, we have extended the results for 3-SAT MDP in Theorem 3.3 to a more general setting as desired. Similar explanations for Theorem 3.8 can be provided, akin to Remarks 3.4, 3.5, and 3.6 for 3-SAT MDPs, but we omit these to avoid repetition.

4 The Separation between Policy-based RL and Value-based RL

In Section 3, we demonstrated the representation complexity gap between model-based RL and model-free RL. In this section, our focus shifts to exploring the potential representation complexity hierarchy within model-free RL, encompassing policy-based RL and value-based RL. More specifically, we construct a broad class of MDPs where both the underlying model and the optimal policy are easy to represent, while the optimal value function is hard to represent. This further illustrates the representation hierarchy between different categories of RL algorithms.

4.1 CVP MDP

We begin by introducing the CVP MDPs, whose construction is rooted in the circuit value problem (CVP). The CVP involves computing the output of a given Boolean circuit (refer to Definition 2.1) on a given input.

Definition 4.1 (CVP MDP). An n -dimensional CVP MDP is defined as follows. Let \mathcal{C} be the set of all circuits of size n . The state space \mathcal{S} is defined by $\mathcal{S} = \mathcal{C} \times \{0, 1, \text{Unknown}\}^n$, where

each state s can be represented as $s = (\mathbf{c}, \mathbf{v})$. Here, \mathbf{c} is a circuit consisting of n nodes with $\mathbf{c}[i] = (\mathbf{c}[i][1], \mathbf{c}[i][2], g_i)$ describing the i -th node, where $\mathbf{c}[i][1]$ and $\mathbf{c}[i][2]$ indicate the input node and g_i denotes the type of gate (including $\wedge, \vee, \neg, 0, 1$). When $g_i \in \{\wedge, \vee\}$, the outputs of $\mathbf{c}[i][1]$ -th node and $\mathbf{c}[i][2]$ -th node serve as the inputs; and when $g_i = \neg$, the output of $\mathbf{c}[i][1]$ -th node serves as the input and $\mathbf{c}[i][2]$ is meaningless. Moreover, the node type of 0 or 1 denotes that the corresponding node is a leaf node with a value of 0 or 1, respectively, and therefore, $\mathbf{c}[i][1], \mathbf{c}[i][2]$ are both meaningless. The vector $\mathbf{v} \in \{0, 1, \text{Unknown}\}^n$ represents the value of the n nodes, where the value **Unknown** indicates that the value of this node has not been computed and is presently unknown. The action space is $\mathcal{A} = [n]$ and the planning horizon is $H = n + 1$. Given a state-action pair $(s = (\mathbf{c}, \mathbf{v}), a)$, its reward $r(s, a)$ is given by:

$$r(s, a) = \begin{cases} 1 & \text{If the value of the output gate } \mathbf{v}[n] = 1, \\ 0 & \text{Otherwise.} \end{cases}$$

Moreover, the transition kernel is deterministic and can be defined as follows:

$$\mathcal{P}((\mathbf{c}, \mathbf{v}), a) = (\mathbf{c}, \mathbf{v}').$$

Here, \mathbf{v}' is obtained from \mathbf{v} by computing and substituting the value of node a . More exactly, if the inputs of node a have been computed, we can compute the output of the node a and denote it as $\mathbf{o}[a]$. Then we have

$$\mathbf{v}'[j] = \begin{cases} \mathbf{v}[j] & \text{If } a \neq j, \\ \mathbf{o}[a] & \text{If } a = j \text{ and the inputs of node } a \text{ have been computed,} \\ \text{Unknown} & \text{If } a = j \text{ and the inputs of node } a \text{ have not been computed.} \end{cases}$$

Given a circuit \mathbf{c} , the initial state of CVP MDP is $(\mathbf{c}, \mathbf{v}_{\text{unknown}})$ where $\mathbf{v}_{\text{unknown}}$ denotes the vector containing n **Unknown** values.

The visualization of CVP MDPs is given in Figure 2. In simple terms, each state $s = (\mathbf{c}, \mathbf{v})$ comprises information about a given size- n circuit \mathbf{c} and a vector $\mathbf{v} \in \{0, 1, \text{Unknown}\}^n$. At each step, the agent takes an action $a \in [n]$. If the a -th node has not been computed, and the input nodes are already computed, then the transition kernel of the CVP MDP modifies $\mathbf{v}[a]$ based on the type of gate $\mathbf{c}[a]$. The agent achieves the maximum reward of 1 only if it transforms the initial vector $\mathbf{v}_{\text{unknown}}$, consisting of n **Unknown** values, into the \mathbf{v} satisfying $\mathbf{v}[n] = 1$. This also indicates that CVP MDPs exhibit the capacity to model many real-world goal-conditioned problems and scenarios featuring sparse rewards. Hence, we have strategically encoded the circuit value problem into the CVP MDP in this manner. The representation complexity guarantee for the CVP MDP is provided below.

Theorem 4.2 (Representation Complexity of CVP MDP). Let \mathcal{M}_n be the n -dimensional CVP MDP defined in Definition 4.1. The reward function r , transition kernel \mathcal{P} , and optimal policy π^* of \mathcal{M}_n can be computed by circuits with polynomial size (in n) and constant depth, falling within the circuit complexity class AC^0 . However, the problem of computing the optimal value function Q_1^* of \mathcal{M}_n is P-complete under the log-space reduction.

Proof of Theorem 4.2. See Appendix C.1 for a detailed proof. \square

Theorem 4.2 illustrates that, within the framework of CVP MDP, the representation complexity of the optimal value function is notably higher than that of the underlying model and optimal policy.

4.2 P MDP: A Broader Class of MDPs

Similar to the extension of 3-SAT MDP to NP MDP in Section 3.2, we broaden the scope of CVP MDP to encompass a broader class of MDPs. In this extension, we can encode *any* P-complete problem into the MDP structure while preserving the results established for CVP MDP in Theorem 4.2. Specifically, we introduce the P MDP as follows.

Definition 4.3 (P MDP). Given a language \mathcal{L} in P, and a circuit family \mathcal{C} , where $\mathcal{C}_n \in \mathcal{C}$ contains the circuits capable of recognizing strings of the length n in \mathcal{L} . The size of the circuits in \mathcal{C}_n is upper bounded by a polynomial $P(n)$. An n -dimensional P MDP based on \mathcal{L} is defined as follows. The state space \mathcal{S} is defined by $\mathcal{S} = \{0, 1\}^n \times \mathcal{C}_n \times \{0, 1, \text{Unknown}\}^{P(n)}$, where each state s can be represented as $s = (\mathbf{x}, \mathbf{c}, \mathbf{v})$. Here, \mathbf{c} is the circuit recognizing the strings of length n in \mathcal{L} with $\mathbf{c}[i] = (\mathbf{c}[i][1], \mathbf{c}[i][2], g_i)$ representing the i -th node where the output of nodes i_1 and i_2 serves as the input, and g_i is the type of the gate (including \wedge, \vee, \neg , and **Input**). When $g_i \in \{\wedge, \vee\}$, the outputs of $\mathbf{c}[i][1]$ -th node and $\mathbf{c}[i][2]$ -th node serve as the inputs; and when $g_i = \neg$, the output of $\mathbf{c}[i][1]$ -th node serves as the input and $\mathbf{c}[i][2]$ is meaningless. Moreover, the type **Input** indicates that the corresponding node is the $\mathbf{c}[i][1]$ -th bit of the input string. The vector $\mathbf{v} \in \{0, 1, \text{Unknown}\}^{P(n)}$ representing the value of the n nodes, and the value **Unknown** indicates that the value of the corresponding node has not been computed, and hence is currently unknown. The action space is $\mathcal{A} = [P(n)]$ and the planning horizon is $H = P(n) + 1$. The reward of any state-action ($s = (\mathbf{x}, \mathbf{c}, \mathbf{v}), a$) is defined by:

$$r(s, a) = \begin{cases} 1 & \text{If the value of the output gate } \mathbf{v}[P(n)] = 1, \\ 0 & \text{Otherwise.} \end{cases}$$

Moreover, the transition kernel is deterministic and can be defined as follows:

$$\mathcal{P}((\mathbf{x}, c, \mathbf{v}), a) = (\mathbf{x}, c, \mathbf{v}'),$$

where \mathbf{v}' is obtained from \mathbf{v} by computing and substituting the value of node a . In particular, if the inputs of node a have been computed or can be read from the input string, we can determine the output of node a and denote it as $\mathbf{o}[a]$. This yields the formal expression of \mathbf{v}' :

$$\mathbf{v}'[j] = \begin{cases} \mathbf{v}[j] & \text{If } a \neq j \\ \mathbf{o}[a] & \text{If } a = j \text{ and the inputs of node } a \text{ have been computed} \\ \text{Unknown} & \text{If } a = j \text{ and the inputs of node } a \text{ have not been computed.} \end{cases}$$

Given an input \mathbf{x} and a circuit \mathbf{c} capable of recognizing strings of specific length in \mathcal{L} , the initial state of P MDP is $(\mathbf{c}, \mathbf{v}_{\text{unknown}})$ where $\mathbf{v}_{\text{unknown}}$ denotes the vector containing $P(n)$ **Unknown** values and $P(n)$ is the size of the circuit \mathbf{c} .

In the definition of P MDPs, we employ circuits to recognize the P-complete language \mathcal{L} instead of using a Turing Machine, as done in the NP MDP in Definition 3.7. While it is possible to define P MDPs using a Turing Machine, we opt for circuits to maintain consistency with CVP MDP and facilitate our proof. Additionally, we remark that employing circuits to define NP MDPs poses challenges, as it remains elusive whether polynomial circuits can recognize NP-complete languages.

Theorem 4.4 (Representation complexity of P MDP). For any P-complete language \mathcal{L} , consider its corresponding (n -dimensional) P MDP \mathcal{M}_n as defined in Definition 4.3. The reward function r , transition kernel \mathcal{P} , and the optimal policy π^* of \mathcal{M}_n can be computed by circuits with polynomial size (in n) and constant depth, falling within the circuit complexity class AC^0 . However, the problem of computing the optimal value function Q_1^* of \mathcal{M}_n is P-complete under the log-space reduction.

Proof of Theorem 4.4. See Appendix C.2 for a detailed proof. \square

Theorem 4.4 significantly broadens the applicability of Theorem 4.2 by enabling the encoding of any P-complete problem into the MDP structure, as opposed to a specific circuit value problem. In these expanded scenarios, the representation complexity of the underlying model and optimal policy remains noticeably lower than that of the optimal value function.

Consequently, by combining the results in Theorems 3.3, 3.8, 4.2, and 4.4, a potential representation complexity hierarchy between model-based RL, policy-based RL, and value-based RL has been unveiled. Specifically, the underlying model is the easiest to represent, followed by the optimal policy function, with the optimal value function exhibiting the highest representation complexity.

5 Connections to Deep Reinforcement Learning

While we have uncovered the representation complexity hierarchy between model-based RL, policy-based RL, and value-based RL through the lens of computational complexity in Sections 3 and 4, these results offer limited insights for modern deep RL, where models, policies, and values are approximated by neural networks. To address this limitation, we further substantiate our revealed representation complexity hierarchy among different RL paradigms through the perspective of the expressiveness of neural networks. Specifically, we focus on the MLP with Rectified Linear Unit (ReLU) as the activation function³ — an architecture predominantly employed in deep RL algorithms. The formal definition is provided below.

Definition 5.1 (Log-precision MLP). An L -layer MLP is a function from input $\mathbf{e}_0 \in \mathbb{R}^d$ to output $\mathbf{y} \in \mathbb{R}^{d_y}$, recursively defined as

$$\begin{aligned} \mathbf{h}_1 &= \text{ReLU}(\mathbf{W}_1 \mathbf{e}_0 + \mathbf{b}_1), & \mathbf{W}_1 &\in \mathbb{R}^{d_1 \times d}, & \mathbf{b}_1 &\in \mathbb{R}^{d_1}, \\ \mathbf{h}_\ell &= \text{ReLU}(\mathbf{W}_\ell \mathbf{h}_{\ell-1} + \mathbf{b}_\ell), & \mathbf{W}_\ell &\in \mathbb{R}^{d_\ell \times d_{\ell-1}}, & \mathbf{b}_\ell &\in \mathbb{R}^{d_\ell}, & 2 \leq \ell \leq L-1, \\ \mathbf{y} &= \mathbf{W}_L \mathbf{h}_L + \mathbf{b}_L, & \mathbf{W}_L &\in \mathbb{R}^{d_y \times d_L}, & \mathbf{b}_L &\in \mathbb{R}^{d_y}, \end{aligned}$$

³Our results in this section are ready to be extended to other activation functions, such as Exponential Linear Unit (ELU), Gaussian Error Linear Unit (GeLU) and so on.

where $\text{ReLU}(x) = \max\{0, x\}$ for any $x \in \mathbb{R}$ is the standard ReLU activation. *Log-precision MLPs* refer to MLPs whose internal neurons can only store floating-point numbers within $O(\log n)$ bit precision, where n is the maximal length of the input dimension.

See Appendix A for more details regarding log precision. The log-precision MLP is closely related to practical scenarios where the precision of the machine (e.g., 16 bits or 32 bits) is generally much smaller than the input dimension (e.g., 1024 or 2048 for the representation of image data). In our paper, all occurrences of MLPs will implicitly refer to the log-precision MLP, and we may omit explicit emphasis on log precision for the sake of simplicity.

To employ the MLP to represent the model, policy, and value function, we encode each state s and action a into embeddings $\mathbf{e}_s \in \mathbb{R}^{d_s}$ and $\mathbf{e}_a \in \mathbb{R}^a$, respectively. The detailed constructions of state embeddings and action embeddings of each type of MDPs are provided in Appendix D.1. Using these embeddings, we specify the input and output of MLPs that represent the model, policy, and value function in the following Table 2.

	Transition Kernel	Reward Function	Optimal Policy	Optimal Value Function
Input	$(\mathbf{e}_s, \mathbf{e}_a)$	$(\mathbf{e}_s, \mathbf{e}_a)$	\mathbf{e}_s	$(\mathbf{e}_s, \mathbf{e}_a)$
Output	$\mathbf{e}_{s'}$	$r(s, a)$	\mathbf{e}_a	$Q_1^*(s, a)$

Table 2: The input and output of the MLPs that represent the model, policy, and value function.

We now unveil the hierarchy of representation complexity from the perspective of MLP expressiveness. To begin with, we demonstrate the representation complexity gap between model-based RL and model-free RL.

Theorem 5.2. The reward function r and transition kernel \mathcal{P} of n -dimensional 3-SAT MDP and NP MDP can be represented by an MLP with constant layers, polynomial hidden dimension (in n), and ReLU as the activation function.

Proof of Theorem 5.2. See Appendix D.2 for a detailed proof. □

Theorem 5.3. Assuming that $\text{TC}^0 \neq \text{NP}$, the optimal policy π_1^* and optimal value function Q_1^* of n -dimensional 3-SAT MDP and NP MDP defined with respect to an NP-complete language \mathcal{L} cannot be represented by an MLP with constant layers, polynomial hidden dimension (in n), and ReLU as the activation function.

Proof of Theorem 5.3. See Appendix D.3 for a detailed proof. □

Theorems 5.2 and 5.3 show that the underlying model of 3-SAT MDP and NP MDP can be represented by constant-layer perceptron, while the optimal policy and optimal value function cannot. This demonstrates the representation complexity gap between model-based RL and model-free RL from the perspective of MLP expressiveness. The following two theorems further illustrate the representation complexity gap between policy-based RL and value-based RL.

Theorem 5.4. The reward function r , transition kernel \mathcal{P} , and optimal policy π^* of n -dimensional CVP MDP and P MDP can be represented by an MLP with constant layers, polynomial hidden dimension (in n), and ReLU as the activation function.

Proof of Theorem 5.4. See Appendix D.4 for a detailed proof. □

Theorem 5.5. Assuming that $\text{TC}^0 \neq \text{P}$, the optimal value function Q_1^* of n -dimensional CVP MDP and P MDP defined with respect to a P-complete language \mathcal{L} cannot be represented by an MLP with constant layers, polynomial hidden dimension (in n), and ReLU as the activation function.

Proof of Theorem 5.5. See Appendix D.5 for a detailed proof. □

Combining Theorems 5.2, 5.3, 5.4, and 5.5, we uncover a potential hierarchy between model-based RL, policy-based RL, and value-based RL, reaffirming the results in Sections 3 and 4 from the perspective of MLP expressiveness. To our best knowledge, this is the first result on representation complexity in RL from the perspective of MLP expressiveness, aligning more closely with modern deep RL and providing valuable insights for practice.

Remark 5.6. The results presented in this section underscore the importance of establishing NP-completeness and P-completeness in Sections 3 and 4. Specifically, constant-layer MLPs with polynomial hidden dimension are unable to simulate P-complete problems and NP-complete problems under the assumptions that $\text{TC}^0 \neq \text{P}$ and $\text{TC}^0 \neq \text{NP}$, which are widely believed to be impossible. In contrast, it is noteworthy that MLPs with constant layers and polynomial hidden dimension can represent basic operations within TC^0 (Lemma F.6), such as the Majority function. Consequently, the model, optimal policy, and optimal value function of “Majority MDPs” presented in Zhu et al. (2023) can be represented by constant-layer MLPs with polynomial size. Hence, the class of MDPs presented in Zhu et al. (2023) cannot demonstrate the representation complexity hierarchy from the lens of MLP expressiveness.

6 Conclusions

This paper studies three RL paradigms — model-based RL, policy-based RL, and value-based RL — from the perspective of representation complexity. Through leveraging computational complexity (including time complexity and circuit complexity) and the expressiveness of MLPs as representation complexity metrics, we unveil a potential hierarchy of representation complexity among different RL paradigms. Our theoretical framework posits that representing the model constitutes the most straightforward task, succeeded by the optimal policy, while representing the optimal value function poses the most intricate challenge. Our work contributes to a deeper understanding of the nuanced complexities inherent in various RL paradigms, providing valuable insights for the advancement of RL methodologies.

Acknowledgements

HZ would like to thank Rui Yang and Tong Zhang for helpful discussions and valuable feedback.

References

- Agarwal, A., Henaff, M., Kakade, S. and Sun, W. (2020). Pc-pg: Policy cover directed exploration for provable policy gradient learning. *Advances in neural information processing systems*, **33** 13399–13412.
- Agarwal, A., Kakade, S. M., Lee, J. D. and Mahajan, G. (2021). On the theory of policy gradient methods: Optimality, approximation, and distribution shift. *The Journal of Machine Learning Research*, **22** 4431–4506.
- Arora, S. and Barak, B. (2009). *Computational complexity: a modern approach*. Cambridge University Press.
- Ayoub, A., Jia, Z., Szepesvari, C., Wang, M. and Yang, L. (2020). Model-based reinforcement learning with value-targeted regression. In *International Conference on Machine Learning*. PMLR.
- Azar, M. G., Osband, I. and Munos, R. (2017). Minimax regret bounds for reinforcement learning. In *International Conference on Machine Learning*. PMLR.
- Cai, Q., Yang, Z., Jin, C. and Wang, Z. (2020). Provably efficient exploration in policy optimization. In *International Conference on Machine Learning*. PMLR.
- Cen, S., Cheng, C., Chen, Y., Wei, Y. and Chi, Y. (2022). Fast global convergence of natural policy gradient methods with entropy regularization. *Operations Research*, **70** 2563–2578.
- Chen, Z., Li, C. J., Yuan, A., Gu, Q. and Jordan, M. I. (2022). A general framework for sample-efficient function approximation in reinforcement learning. *arXiv preprint arXiv:2209.15634*.
- Cook, S. A. (1971). The complexity of theorem-proving procedures. In *Proceedings of the Third Annual ACM Symposium on Theory of Computing*. ACM, 1971.
- Dong, K., Luo, Y., Yu, T., Finn, C. and Ma, T. (2020). On the expressivity of neural networks for deep reinforcement learning. In *International conference on machine learning*. PMLR.
- Du, S., Kakade, S., Lee, J., Lovett, S., Mahajan, G., Sun, W. and Wang, R. (2021). Bilinear classes: A structural framework for provable generalization in rl. In *International Conference on Machine Learning*. PMLR.
- Du, S. S., Kakade, S. M., Wang, R. and Yang, L. F. (2019). Is a good representation sufficient for sample efficient reinforcement learning? *arXiv preprint arXiv:1910.03016*.

- Foster, D. J., Kakade, S. M., Qian, J. and Rakhlin, A. (2021). The statistical complexity of interactive decision making. *arXiv preprint arXiv:2112.13487*.
- Jaksch, T., Ortner, R. and Auer, P. (2010). Near-optimal regret bounds for reinforcement learning. *Journal of Machine Learning Research*, **11** 1563–1600.
- Janner, M., Fu, J., Zhang, M. and Levine, S. (2019). When to trust your model: Model-based policy optimization. *Advances in neural information processing systems*, **32**.
- Jiang, N., Krishnamurthy, A., Agarwal, A., Langford, J. and Schapire, R. E. (2017). Contextual decision processes with low Bellman rank are PAC-learnable. In *Proceedings of the 34th International Conference on Machine Learning*, vol. 70 of *Proceedings of Machine Learning Research*. PMLR.
- Jin, C., Allen-Zhu, Z., Bubeck, S. and Jordan, M. I. (2018). Is q-learning provably efficient? *Advances in neural information processing systems*, **31**.
- Jin, C., Liu, Q. and Miryoosefi, S. (2021). Bellman eluder dimension: New rich classes of rl problems, and sample-efficient algorithms. *Advances in neural information processing systems*, **34** 13406–13418.
- Jin, C., Yang, Z., Wang, Z. and Jordan, M. I. (2020). Provably efficient reinforcement learning with linear function approximation. In *Conference on Learning Theory*. PMLR.
- Jin, Y., Ren, Z., Yang, Z. and Wang, Z. (2022). Policy learning” without”overlap: Pessimism and generalized empirical bernstein’s inequality. *arXiv preprint arXiv:2212.09900*.
- Kakade, S. M. (2001). A natural policy gradient. *Advances in neural information processing systems*, **14**.
- Kober, J., Bagnell, J. A. and Peters, J. (2013). Reinforcement learning in robotics: A survey. *The International Journal of Robotics Research*, **32** 1238–1274.
- Ladner, R. E. (1975). The circuit value problem is log space complete for p. *ACM Sigact News*, **7** 18–20.
- Lan, G. (2023). Policy mirror descent for reinforcement learning: Linear convergence, new sampling complexity, and generalized problem classes. *Mathematical programming*, **198** 1059–1106.
- LeCun, Y., Bengio, Y. and Hinton, G. (2015). Deep learning. *nature*, **521** 436–444.
- Levin, L. A. (1973). Universal sequential search problems. *Problemy peredachi informatsii*, **9** 115–116.
- Liu, B., Cai, Q., Yang, Z. and Wang, Z. (2019). Neural trust region/proximal policy optimization attains globally optimal policy. *Advances in neural information processing systems*, **32**.

- Liu, Q., Weisz, G., György, A., Jin, C. and Szepesvári, C. (2023a). Optimistic natural policy gradient: a simple efficient policy optimization framework for online rl. *arXiv preprint arXiv:2305.11032*.
- Liu, Z., Lu, M., Xiong, W., Zhong, H., Hu, H., Zhang, S., Zheng, S., Yang, Z. and Wang, Z. (2023b). One objective to rule them all: A maximization objective fusing estimation and planning for exploration. *arXiv preprint arXiv:2305.18258*.
- Merrill, W. and Sabharwal, A. (2023). The parallelism tradeoff: Limitations of log-precision transformers. *Transactions of the Association for Computational Linguistics*, **11** 531–545.
- Schulman, J., Wolski, F., Dhariwal, P., Radford, A. and Klimov, O. (2017). Proximal policy optimization algorithms. *arXiv preprint arXiv:1707.06347*.
- Shani, L., Efroni, Y., Rosenberg, A. and Mannor, S. (2020). Optimistic policy optimization with bandit feedback. In *International Conference on Machine Learning*. PMLR.
- Sherman, U., Cohen, A., Koren, T. and Mansour, Y. (2023). Rate-optimal policy optimization for linear markov decision processes. *arXiv preprint arXiv:2308.14642*.
- Silver, D., Huang, A., Maddison, C. J., Guez, A., Sifre, L., Van Den Driessche, G., Schrittwieser, J., Antonoglou, I., Panneershelvam, V., Lanctot, M. et al. (2016). Mastering the game of go with deep neural networks and tree search. *nature*, **529** 484–489.
- Sun, W., Jiang, N., Krishnamurthy, A., Agarwal, A. and Langford, J. (2019). Model-based rl in contextual decision processes: Pac bounds and exponential improvements over model-free approaches. In *Conference on learning theory*. PMLR.
- Sutton, R. S. and Barto, A. G. (2018). *Reinforcement learning: An introduction*. MIT press.
- Sutton, R. S., McAllester, D., Singh, S. and Mansour, Y. (1999). Policy gradient methods for reinforcement learning with function approximation. *Advances in neural information processing systems*, **12**.
- Tu, S. and Recht, B. (2019). The gap between model-based and model-free methods on the linear quadratic regulator: An asymptotic viewpoint. In *Conference on Learning Theory*. PMLR.
- Uehara, M. and Sun, W. (2021). Pessimistic model-based offline reinforcement learning under partial coverage. *arXiv preprint arXiv:2107.06226*.
- Wu, T., Yang, Y., Zhong, H., Wang, L., Du, S. and Jiao, J. (2022). Nearly optimal policy optimization with stable at any time guarantee. In *International Conference on Machine Learning*. PMLR.
- Xiao, L. (2022). On the convergence rates of policy gradient methods. *The Journal of Machine Learning Research*, **23** 12887–12922.

- Xie, T., Cheng, C.-A., Jiang, N., Mineiro, P. and Agarwal, A. (2021). Bellman-consistent pessimism for offline reinforcement learning. *Advances in neural information processing systems*, **34** 6683–6694.
- Xu, Y. and Zeevi, A. (2023). Bayesian design principles for frequentist sequential learning. In *International Conference on Machine Learning*. PMLR.
- Yang, L. and Wang, M. (2019). Sample-optimal parametric q-learning using linearly additive features. In *International Conference on Machine Learning*. PMLR.
- Yu, T., Thomas, G., Yu, L., Ermon, S., Zou, J. Y., Levine, S., Finn, C. and Ma, T. (2020). Mopo: Model-based offline policy optimization. *Advances in Neural Information Processing Systems*, **33** 14129–14142.
- Zanette, A. and Brunskill, E. (2019). Tighter problem-dependent regret bounds in reinforcement learning without domain knowledge using value function bounds. In *International Conference on Machine Learning*. PMLR.
- Zhang, Z., Chen, Y., Lee, J. D. and Du, S. S. (2023). Settling the sample complexity of online reinforcement learning. *arXiv preprint arXiv:2307.13586*.
- Zhang, Z., Ji, X. and Du, S. (2021). Is reinforcement learning more difficult than bandits? a near-optimal algorithm escaping the curse of horizon. In *Conference on Learning Theory*. PMLR.
- Zhong, H., Xiong, W., Zheng, S., Wang, L., Wang, Z., Yang, Z. and Zhang, T. (2022). Gec: A unified framework for interactive decision making in mdp, pomdp, and beyond. *arXiv preprint arXiv:2211.01962*.
- Zhong, H., Yang, Z., Wang, Z. and Szepesvári, C. (2021). Optimistic policy optimization is provably efficient in non-stationary mdps. *arXiv preprint arXiv:2110.08984*.
- Zhong, H. and Zhang, T. (2023). A theoretical analysis of optimistic proximal policy optimization in linear markov decision processes. *arXiv preprint arXiv:2305.08841*.
- Zhou, D., Gu, Q. and Szepesvari, C. (2021). Nearly minimax optimal reinforcement learning for linear mixture markov decision processes. In *Conference on Learning Theory*. PMLR.
- Zhu, H., Huang, B. and Russell, S. (2023). On representation complexity of model-based and model-free reinforcement learning. *arXiv preprint arXiv:2310.01706*.

A Additional Background Knowledge

We will introduce some additional background knowledge in this section, including the Turing Machine, the uniformity of circuits, and log precision.

Definition of Turing Machine. We give the formal definition of the Turing Machine as follows:

Definition A.1 (Turing Machine). A *deterministic Turing Machine (TM)* M is described by a tuple $(\Gamma, \mathbb{Q}, \mathbb{T})$, where Γ is the tape *alphabet* containing the “blank” symbol, “start” symbol, and the numbers 0 and 1; \mathbb{Q} is a finite, non-empty set of states, including a start state q_{start} and a halting state q_{halting} ; and $\mathbb{T} : \mathbb{Q} \times \Gamma^k \mapsto \mathbb{Q} \times \Gamma^{k-1} \times \{\text{Left, Stay, Right}\}$, where $k \geq 2$, is the *transition function*, describing the rules M use in each step. The only difference between a *nondeterministic Turing Machine (NDTM)* and a deterministic Turing Machine is that an NDTM has two transition functions \mathbb{T}_0 and \mathbb{T}_1 , and a special state q_{accept} . At each step, the NDTM can choose one of two transitions to apply, and accept the input if there *exists* some sequence of these choices making the NDTM reach q_{accept} . A *configuration* of (deterministic or nondeterministic) Turing Machine M consists of the contents of all nonblank entries on the tapes of M , the machine’s current state, and the pointer on the tapes.

Uniformity of Circuits. Given a circuit family \mathcal{C} , where $\mathbf{c}_i \in \mathcal{C}$ is the circuit takes n bits as input, the uniformity condition is often imposed on the circuit family, requiring the existence of some possibly resource-bounded Turing machine that, on input n , produces a description of the individual circuit \mathbf{c}_n . When this Turing machine has a running time polynomial in n , the circuit family \mathcal{C} is said to be P-uniform. And when this Turing machine has a space logarithmic in n , the circuit family \mathcal{C} is said to be L-uniform.

Log Precision. In this work, we focus on MLPs, of which neuron values are restricted to be floating-point numbers of logarithmic (in the input dimension n) precision, and all computations operated on floating-point numbers will be finally truncated, similar to how a computer processes real numbers. Specifically, the log-precision assumption means that we can use $O(\log(n))$ bits to represent a real number, where the dimension of the input sequence is bounded by n . An important property is that it can represent all real numbers of magnitude $O(\text{poly}(n))$ within $O(\text{poly}(1/n))$ truncation error.

B Proofs for Section 3

B.1 Proof of Theorem 3.3

Proof of Theorem 3.3. We investigate the representation complexity of the reward function, transition kernel, optimal value function, and optimal policy in sequence.

Reward Function. First, we prove the reward function can be implemented by AC^0 circuits. Given a literal $\alpha \in \{u_1, u_2, \dots, u_n, \neg u_1, \neg u_2, \dots, \neg u_n\}$, we can obtain its value by

$$\alpha = \left(\bigvee_{j \in [n]} (\mathbf{v}[j] \wedge \mathbb{1}[\alpha = u_i]) \right) \vee \left(\bigvee_{j \in [n]} (\neg \mathbf{v}[j] \wedge \mathbb{1}[\alpha = \neg u_i]) \right).$$

After substituting the literal by its value under the assignment \mathbf{v} , we can calculate the 3-CNF Boolean formula $\psi(\mathbf{v})$ by two-layer circuits as its definition. Then the reward can be expressed as

$$r(s, a) = \mathbb{1}[\psi(\mathbf{v}) \wedge k = n + 1] + 0.5 \cdot \mathbb{1}[k = 2n + 2],$$

which further implies that the reward function can be implemented by AC^0 circuits.

Transition Kernel. Then, we will implement the transition kernel by AC^0 circuits. It is noted that we only need to modify the assignment \mathbf{v}, k . Given the input \mathbf{v}, k and a , we have the output as follows:

$$\begin{aligned} \psi' &= \psi, & \mathbf{v}'[i] &= (\mathbf{v}[i] \wedge \mathbb{1}[i \neq k]) \vee (a \wedge \mathbb{1}[i = k]), \\ k' &= (k + 1) \cdot \mathbb{1}[k \geq 1] + \mathbb{1}[k = 0 \wedge a = 1] + (n + 2) \cdot \mathbb{1}[a = k = 0]. \end{aligned} \tag{B.1}$$

It is noted that each element in the output is determined by at most $O(\log n)$ bits. Therefore, according to Lemma F.4, each bit of the output can be computed by two-layer circuits of polynomial size, and the overall output can be computed by AC^0 circuits.

Optimal Policy. We aim to show that, given a state $s = (\psi, \mathbf{v}, k)$ as input, the problem of judging whether $\pi_1^*(s) = 1$ is NP-complete. We give a two-step proof.

Step 1. We first verify that this problem is in NP. Given a satisfiable assignment \mathbf{v}^* as the certificate, we only need to verify the following things to determine whether there exists a sequence of actions to achieve the final reward of 1:

- The assignment is satisfiable;
- When $k \in [n]$ or $k = 0$, $\mathbf{v}[i] = \mathbf{v}^*[i], i \in [k]$ and $\mathbf{v}^*[k + 1] = 1$.

Notably, when exist such certificates, action $a = 1$ yields the reward of 1 and is consequently optimal. Conversely, when such certificates are absent, action $a = 1$ leads to the reward of 0, and in this case, $a = 0$ is the optimal action. Moreover, when $k = n + 1$ or $k = n + 2$, selecting $a = 1$ is always optimal. Consequently, given the certificates, we can verify whether $\pi_1^*(\psi, \mathbf{0}_n, 0) = 1$.

Step 2. Meanwhile, according to the well-known Cook-Levin theorem (Lemma F.1), the 3-SAT problem is NP-complete. Thus, our objective is to provide a polynomial time reduction from the 3-SAT problem to the problem of computing the optimal policy of 3-SAT MDP. Given a Boolean formula of length n , the number of variables is at most n . Then, we can pad several meaningless clauses such as $(u_1 \vee \neg u_1 \vee u_1)$ to obtain the 3-CNF Boolean formula ψ' with n clauses. Then the Boolean formula ψ is satisfiable if and only if $\pi_1^*(\psi', \mathbf{0}_n, 0) = 1$. This provides a desired polynomial time reduction.

Optimal Value Function. To show the NP-completeness of computing the optimal value function, we formulate the decision version of this problem: given a state $s = (\psi, \mathbf{v}, k)$, an action a and a number γ as input, and the goal is to determine whether $Q_1^*(s, a) > \gamma$. According to the definition of NP-completeness, we need to prove that this problem belongs to the complexity class NP and then provide a polynomial-time reduction from a recognized NP-complete problem to this problem. These constitute the objectives of the subsequent two steps.

Step 1. We first verify that this problem is in NP. Given the input state $s = (\psi, \mathbf{v}, k)$, input action a , and input real number γ , we use the assignments \mathbf{v}' of ψ as certificates. When $\gamma \geq 1$, the verifier Turing Machine will reject the inputs, and when $\gamma < 0$, the verifier Turing Machine will accept the inputs. When $\gamma \in [0.5, 1)$, the verifier Turing Machine will accept the input when there exists a \mathbf{v}' satisfying the following two conditions:

- The assignment \mathbf{v}' is satisfiable for ψ
- When $k \in [n]$, it holds that $\mathbf{v}[i] = \mathbf{v}'[i]$ for all $i \in [k]$.

When $\gamma \in [0, 0.5)$, except in the scenario where the aforementioned two conditions are met, the verifier Turing Machine will additionally accept the input when $k = a = 0$. Then we have $Q_1^*(s, a) > \gamma$ if and only if there exists a certificate \mathbf{v}' such that the verifier Turing Machine accepts the input containing s, a, γ , and the assignment \mathbf{v}' . Moreover, the verifier Turing Machine runs in at most polynomial time. Therefore, this problem is in NP.

Step 2. Meanwhile, according to the well-known Cook-Levin theorem (Lemma F.1), the 3-SAT problem is NP-complete. Thus, our objective is to provide a polynomial time reduction from the 3-SAT problem to the computation of the optimal value function for the 3-SAT MDP. Given a Boolean formula of length n , the number of variables is at most n . Then, we can pad several meaningless clauses such as $(u_1 \vee \neg u_1 \vee u_1)$ to obtain the 3-CNF Boolean formula ψ' with n clauses. The Boolean formula ψ is satisfiable if and only if $Q_1^*((\psi', \mathbf{0}_n, 0), 1) > \frac{3}{4}$, which gives us a desired polynomial time reduction.

Combining these two steps, we can conclude that computing the optimal value function is NP-complete. \square

B.2 Proof of Theorem 3.8

Proof of Theorem 3.8. Following the proof paradigm of Theorem 3.3, we characterize the representation complexity of the reward function, transition kernel, optimal policy, and optimal value function in sequence.

Reward Function. Given the state $s = (s_M, \mathbf{t}, l, k)$, the output of the reward

$$r(s, a) = \mathbb{1}[s_M = s_{\text{accept}} \wedge k = P(n) + 1] + 0.5 \cdot \mathbb{1}[k = 2P(n) + 2]. \quad (\text{B.2})$$

It is not difficult to see that the reward function can be implemented by AC^0 circuits.

Transition Kernel. We establish the representation complexity of the transition kernel by providing the computation formula for each element of the transited state. Our proof hinges on the observation that, for a state $s = (s_M, \mathbf{t}, l, k)$, we can extract the content x of the location l on the tape by the following formula:

$$\chi = \bigwedge_{i \in [P(n)]} (\mathbb{1}[i = l] \vee \mathbf{t}[i])$$

It is noted that we assume the contents written on the tape are 0 and 1. However, for the general case, we can readily extend the formula by applying it to each bit of the binary representation of the contents. Regarding the configuration $c' = (s'_M, \mathbf{t}', l')$ defined in (3.4), we observe that

- (i) the Turing Machine state s'_M is determined by s_M, a and χ ;
- (ii) the content of the location l on the tape, $\mathbf{t}'[l]$, is determined by s_M, a and χ , whereas the contents of the other locations on the tape remain unaltered, i.e., $\mathbf{t}'[i] = \mathbf{t}[i]$ for $i \neq k$;
- (iii) the pointer l' is determined by l, s_M, a and χ .

Moreover, the number of steps k' is determined by k and a . Therefore, each element in the output is determined by at most $O(\log n)$ bits. According to Lemma F.4, each bit of the output can be computed by two-layer circuits of polynomial size, and the output can be computed by the AC^0 circuits.

Optimal Policy. Our objective is to demonstrate the NP-completeness of the problem of determining whether $\pi_1^*(s) = 1$, given a state $s = (\psi, \mathbf{v}, k)$ as input. We will begin by establishing that this problem falls within the class NP, and subsequently, we will provide a polynomial-time reduction from the NP-complete language \mathcal{L} to this specific problem.

Step 1. Given a sequence of choice of the branch as the certificate, we only need to verify the following two conditions to determine whether the optimal action $a = 1$:

- The final state of the Turing Machine M is the accepted state.
- When $k \in [P(n)]$, the configuration of the Turing Machine after k -steps execution under the choice provided by the certificate is the same as the configuration in the current state.
- When $k \in [P(n)]$, the choice of the k -th step is branch 1.

Note that, when exist such certificates, action $a = 1$ can always get the reward of 1 and is therefore optimal, and otherwise, action $a = 1$ always gets the reward of 0, and $a = 0$ is always optimal. Moreover, when $k = P(n) + 1$ or $k = P(n) + 2$, we can always select the action $a = 1$ as the optimal action. So given the certificates, we can verify whether $\pi_1^*(\psi, \mathbf{0}_n, 0) = 1$.

Step 2. Given an input string s_{input} of length n . We can simply get the initial configuration c_0 of the Turing Machine M on the input s_{input} . Then $s_{\text{input}} \in \mathcal{L}$ if and only if $\pi_1^*((c_0, 0)) = 1$, which gives us a desired polynomial time reduction.

Combining these two steps, we know that computing the optimal policy of NP MDP is NP-complete.

Optimal Value Function. To facilitate our analysis, we consider the decision version of the problem of computing the optimal value function as follows: given a state $s = (s_M, \mathbf{t}, l, k)$, an action a , and a number γ as input, and the goal is to determine whether $Q_1^*(s, a) > \gamma$.

Step 1. We first verify that the problem falls within the class NP. Given the input state s , we use a sequence of choice of the branch as the certificate. When $\gamma \geq 1$, the verifier Turing Machine will reject the inputs, and when $\gamma < 0$, the verifier Turing Machine will accept the input. When $\gamma \in [0.5, 1)$, the Turing Machine accepts the input when there is a certificate that satisfies the following two conditions:

- The final state of the Turing Machine M is s_{accept} .

- When $k \in [P(n)]$, the configuration of the Turing Machine after k -steps execution under the choice provided by the certificate is the same as the configuration in the current state.

When $\gamma \in [0, 0.5)$, in the scenario where the aforementioned two conditions are met, the verifier Turing Machine will additionally accept the input when $k = a = 0$. Note that, all these conditions can be verified in polynomial time. Therefore, given the appropriate certificates, we can verify whether $Q_1^*(s, a) > \gamma$ in polynomial time.

Step 2. Given that \mathcal{L} is NP-complete, it suffices to provide a polynomial time reduction from the \mathcal{L} to the problem of computing the optimal value function of NP MDP. Let s_{input} be an input string of length n . To obtain the initial configuration c_0 of the Turing Machine M on the input s_{input} , we simply copy the input string onto the tape, set the pointer to the initial location, and designate the state of the Turing Machine as the initial state. Therefore, $s_{\text{input}} \in \mathcal{L}$ if and only if $Q_1^*((c_0, 0), 1) > \frac{3}{4}$, which provides a desired polynomial time.

Combining these two steps, we can conclude that computing the optimal value function of NP MDP is NP-complete. \square

C Proofs for Section 4

C.1 Proof of Theorem 4.2

Proof of Theorem 4.2. We characterize the representation complexity of the reward function, transition kernel, optimal policy, and optimal value function in sequence.

Reward Function. First, we prove that the reward function of CVP MDP can be computed by AC^0 circuits. According to the definition, the output is

$$r(s, a) = \mathbb{1}[\mathbf{v}[n] = 1].$$

Therefore, the problem of computing the reward function falls within the complexity class AC^0 .

Transition Kernel. Then, we prove that the transition kernel of CVP MDP can be computed by AC^0 circuits. Given the state-action pair $(s = (\mathbf{c}, \mathbf{v}), a)$, we denote the next state $\mathcal{P}(s, a)$ as $s' = (\mathbf{c}', \mathbf{v}')$. For any index $i \in [n]$, we can simply fetch the node $\mathbf{c}[i]$ and its value by

$$\mathbf{c}[i] = \bigvee_{j \in [n]} (\mathbf{c}[j] \wedge \mathbb{1}[i = j]), \quad \mathbf{v}[i] = \bigvee_{j \in [n]} (\mathbf{v}[j] \wedge \mathbb{1}[i = j]), \quad (\text{C.1})$$

where the AND and OR operations are bit-wise operations. Given the node $\mathbf{c}[a]$ and its inputs $\mathbf{v}[\mathbf{c}[a][1]]$ and $\mathbf{v}[\mathbf{c}[a][2]]$, we calculate the value of the a -th node and denote it as $\bar{\mathbf{o}}[a]$. Here, $\bar{\mathbf{o}}[a]$ represents the correct output of the a -th node when its inputs are computed, and is undefined when the inputs of the a -th node have not been computed. Therefore, let $\bar{\mathbf{o}}[a]$ be **Unknown** when

the inputs of the a -th node have not been computed. Specifically, we can compute $\bar{\mathbf{o}}[a]$ as follows:

$$\begin{aligned}
\bar{\mathbf{o}}[a] = & \left(\mathbb{1}[g_a = \wedge] \wedge \mathbb{1}[\mathbf{v}[\mathbf{c}[i][1]], \mathbf{v}[\mathbf{c}[i][2]] \neq \text{Unknown}] \wedge (\mathbf{v}[\mathbf{c}[i][1]] \wedge \mathbf{v}[\mathbf{c}[i][2]]) \right) \\
& \vee \left(\mathbb{1}[g_a = \vee] \wedge \mathbb{1}[\mathbf{v}[\mathbf{c}[i][1]], \mathbf{v}[\mathbf{c}[i][2]] \neq \text{Unknown}] \wedge (\mathbf{v}[\mathbf{c}[i][1]] \vee \mathbf{v}[\mathbf{c}[i][2]]) \right) \\
& \vee \left(\mathbb{1}[g_a = \neg] \wedge \mathbb{1}[\mathbf{v}[\mathbf{c}[i][1]] \neq \text{Unknown}] \wedge (\neg \mathbf{v}[\mathbf{c}[i][1]]) \right) \vee \left(\mathbb{1}[g_a \in \{0, 1\}] \wedge g_a \right) \quad (\text{C.2}) \\
& \vee \left(\text{Unknown} \wedge \left((\mathbb{1}[g_a \in \{\vee, \wedge\}] \wedge \mathbb{1}[\text{Unknown} \in \{\mathbf{v}[\mathbf{c}[i][1]], \mathbf{v}[\mathbf{c}[i][2]]\}]) \vee \right. \right. \\
& \quad \left. \left. (\mathbb{1}[g_a = \neg] \wedge \mathbb{1}[\mathbf{v}[\mathbf{c}[i][1]] = \text{Unknown}]) \right) \right).
\end{aligned}$$

Furthermore, we can express $s' = (\mathbf{c}', \mathbf{v}')$, the output of the transition kernel, as

$$\mathbf{c}' = \mathbf{c}, \quad \mathbf{v}'[i] = (\bar{\mathbf{o}}[a] \wedge \mathbb{1}[i = a]) \wedge (\mathbf{v}[i] \wedge \mathbb{1}[i \neq a]),$$

which implies that the transition kernel of CVP MDP can be computed by AC^0 circuits.

Optimal Policy. Based on our construction of CVP MDP, it is not difficult to see that $\pi_1^* = \pi_2^* = \dots = \pi_H^*$. For simplicity, we omit the subscript and use π^* to represent the optimal policy. Intuitively, the optimal policy is that given a state $s = (\mathbf{c}, \mathbf{v})$, we find the nodes with the smallest index among the nodes whose inputs have been computed and output has not been computed. Formally, this optimal policy can be expressed as follows. Given a state $s = (\mathbf{c}, \mathbf{v})$, denoting $\mathbf{c}[i] = (\mathbf{c}[i][1], \mathbf{c}[i][2], g_i)$, let $\mathcal{G}(s)$ be a set defined by:

$$\begin{aligned}
\mathcal{G}(s) = & \{i \in [n] \mid g_i \in \{\wedge, \vee\}, \mathbf{v}[\mathbf{c}[i][1]], \mathbf{v}[\mathbf{c}[i][2]] \in \{0, 1\}, \mathbf{v}[i] = \text{Unknown}\} \\
& \cup \{i \in [n] \mid g_i = \neg, \mathbf{v}[\mathbf{c}[i][1]] \in \{0, 1\}, \mathbf{v}[i] = \text{Unknown}\} \quad (\text{C.3}) \\
& \cup \{i \in [n] \mid g_i \in \{0, 1\}, \mathbf{v}[i] = \text{Unknown}\}.
\end{aligned}$$

The set $\mathcal{G}(s)$ defined in (C.3) denotes the indices for which inputs have been computed, and the output has not been computed. Consequently, the optimal policy $\pi^*(s)$ is expressed as $\pi^*(s) = \min \mathcal{G}(s)$. If the output of the circuit \mathbf{c} is 1, the policy π^* can always get the reward 1, establishing its optimality. And if the output of circuit \mathbf{c} is 0, the optimal value is 0 and π^* is also optimal. Therefore, we have verified that the $\pi^* = \min \mathcal{G}(s)$ defined by us is indeed the optimal policy. Subsequently, we aim to demonstrate that the computational complexity of π^* resides within AC^0 . Let $\Upsilon[i]$ denote the indicator of whether $i \in \mathcal{G}(s)$, i.e., $\Upsilon[i] = 1$ signifies that $i \in \mathcal{G}(s)$, while $\Upsilon[i] = 0$ denotes that $i \notin \mathcal{G}(s)$. According to (C.3), we can compute $\Upsilon[i]$ as follows:

$$\begin{aligned}
\Upsilon[i] = & (\mathbb{1}[g_i \in \{\wedge, \vee\}] \wedge \mathbb{1}[\mathbf{v}[\mathbf{c}[i][1]], \mathbf{v}[\mathbf{c}[i][2]] \in \{0, 1\}] \wedge \mathbb{1}[\mathbf{v}[i] = \text{Unknown}]) \\
& \vee (\mathbb{1}[g_i = \neg] \wedge \mathbb{1}[\mathbf{v}[\mathbf{c}[i][1]] \in \{0, 1\}] \wedge \mathbb{1}[\mathbf{v}[i] = \text{Unknown}]) \\
& \vee (\mathbb{1}[g_i \in \{0, 1\}] \wedge \mathbb{1}[\mathbf{v}[i] = \text{Unknown}]).
\end{aligned}$$

Under this notation, we arrive at the subsequent expression for the optimal policy π^* :

$$\pi^*(s) = \bigvee_{i \in [n]} (\Upsilon'[i] \wedge i), \quad \text{where } \Upsilon'[i] = \neg \left(\bigvee_{j < i} \Upsilon[j] \right) \wedge \Upsilon[i].$$

Therefore, the computation complexity of the optimal policy falls in AC^0 .

Optimal Value Function. We prove that the computation of the value function of CVP MDP is P-complete under the log-space reduction. Considering that the reward in a CVP MDP is constrained to be either 0 or 1, we focus on the decision version of the optimal value function computation. Given a state $s = (\mathbf{c}, \mathbf{v})$ and an action a as input, the objective is to determine whether $Q_1^*(s, a) = 1$. In the subsequent two steps, we demonstrate that this problem is within the complexity class P and offer a log-space reduction from a known P-complete problem (CVP problem) to this decision problem.

Step 1. We first verify the problem is in P. According to the definition, a state $s = (\mathbf{c}, \mathbf{v})$ can get the reward 1 if and only if the output of \mathbf{c} is 1. A natural algorithm to compute the value of the circuit \mathbf{c} is computing the values of nodes with the topological order. The algorithm runs in polynomial time, indicating that the problem is in P.

Step 2. Then we prove that the problem is P-complete under the log-space reduction. According to Lemma F.2, the CVP problem is P-complete. Thus, our objective is to provide a log-space reduction from the CVP problem to the computation of the optimal value function for the CVP MDP. Given a circuit \mathbf{c} of size n and a vector $\mathbf{v}_{\text{unknown}}$ containing n Unknown values, consider $s = (\mathbf{c}, \mathbf{v}_{\text{unknown}})$. Let $i = \pi^*(s)$, where the optimal policy π^* is defined in the proof of the “optimal policy function” part. The output of \mathbf{c} is 1 if and only if $Q_1^*(s, i) = 1$. Furthermore, the reduction is accomplished by circuits in AC^0 and, consequently, falls within L.

Combining these two steps, we know that computing the optimal value function is P-complete under the log-space reduction. \square

C.2 Proof of Theorem 4.4

Proof of Theorem 4.4. We characterize the representation complexity of the reward function, transition kernel, optimal policy, and optimal value function in P MDPs in sequence.

Reward Function. We prove that the reward function of P MDP can be computed by AC^0 circuits. According to the definition, the output is

$$r(s, a) = \mathbb{1}[\mathbf{v}[P(n)] = 1].$$

So the complexity of the reward function falls within the complexity class AC^0 .

Transition Kernel. First, we prove that the transition kernel of P MDP can be computed by AC^0 circuits. Given a state-action pair $(s = (\mathbf{x}, \mathbf{c}, \mathbf{v}), a)$, we denote the next state $\mathcal{P}(s, a)$ by $s' = (\mathbf{x}', \mathbf{c}', \mathbf{v}')$. Similar to (C.1) in the proof of Theorem 4.2, we can fetch the node $\mathbf{c}[i]$, its value $\mathbf{v}[i]$, and the i -th character of the input string $\mathbf{x}[i]$. We need to compute the output of the a -th node. Given the node $\mathbf{c}[a]$ and its inputs $\mathbf{v}[\mathbf{c}[a][1]]$ and $\mathbf{v}[\mathbf{c}[a][2]]$ or $\mathbf{x}[\mathbf{c}[a][1]]$, we can compute the a -th node’s value $\bar{\mathbf{o}}[a]$ similar to (C.2), where $\bar{\mathbf{o}}[a]$ is the correct output of the a -th node if the inputs are computed, and is Unknown when the inputs of the a -th node contain the Unknown value.

In detail, \bar{o} can be computed as Here, $\bar{o}[a]$ can be computed as:

$$\begin{aligned}
\bar{o}[a] = & \left(\mathbb{1}[g_a = \wedge] \wedge \mathbb{1}[\mathbf{v}[\mathbf{c}[i][1]], \mathbf{v}[\mathbf{c}[i][2]] \neq \text{Unknown}] \wedge (\mathbf{v}[\mathbf{c}[i][1]] \wedge \mathbf{v}[\mathbf{c}[i][2]]) \right) \\
& \vee \left(\mathbb{1}[g_a = \vee] \wedge \mathbb{1}[\mathbf{v}[\mathbf{c}[i][1]], \mathbf{v}[\mathbf{c}[i][2]] \neq \text{Unknown}] \wedge (\mathbf{v}[\mathbf{c}[i][1]] \vee \mathbf{v}[\mathbf{c}[i][2]]) \right) \\
& \vee \left(\mathbb{1}[g_a = \neg] \wedge \mathbb{1}[\mathbf{v}[\mathbf{c}[i][1]] \neq \text{Unknown}] \wedge (\neg \mathbf{v}[\mathbf{c}[i][1]]) \right) \\
& \vee \left(\mathbb{1}[g_a = \text{Input}] \wedge \mathbf{x}[\mathbf{c}[i][1]] \right) \\
& \vee \left(\text{Unknown} \wedge \left((\mathbb{1}[g_a \in \{\vee, \wedge\}] \wedge \mathbb{1}[\text{Unknown} \in \{\mathbf{v}[\mathbf{c}[i][1]], \mathbf{v}[\mathbf{c}[i][2]\}]) \vee \right. \right. \\
& \quad \left. \left. (\mathbb{1}[g_a = \neg] \wedge \mathbb{1}[\mathbf{v}[\mathbf{c}[i][1]] = \text{Unknown}]) \right) \right).
\end{aligned} \tag{C.4}$$

Then the next state $s' = (\mathbf{x}', \mathbf{c}', \mathbf{v}')$ can be expressed as

$$\mathbf{x}' = \mathbf{x}, \quad \mathbf{c}' = \mathbf{c}, \quad \mathbf{v}'[i] = (\mathbf{o}[a] \wedge \mathbb{1}[i = a]) \wedge (\mathbf{v}[i] \wedge \mathbb{1}[i \neq a]),$$

which yields that the transition kernel of P MDP can be computed by AC^0 circuits.

Optimal Policy. Given a state $s = (\mathbf{x}, \mathbf{c}, \mathbf{v})$, the optimal policy finds the nodes with the smallest index among the nodes whose inputs have been computed and output has not been computed. To formally define the optimal policy, we need to introduce the notation $\tilde{\mathcal{G}}(s)$ to represent the set of indices of which inputs have been computed and output has not been computed. Given a state $s = (\mathbf{x}, \mathbf{c}, \mathbf{v})$, denoting $\mathbf{c}[i] = (\mathbf{c}[i][1], \mathbf{c}[i][2], g_i)$, the set $\tilde{\mathcal{G}}(s)$ is defined by:

$$\begin{aligned}
\tilde{\mathcal{G}}(s) = & \{i \in [P(n)] \mid g_i \in \{\wedge, \vee\}, \mathbf{v}[\mathbf{c}[i][1]], \mathbf{v}[\mathbf{c}[i][2]] \in \{0, 1\}, \mathbf{v}[i] = \text{Unknown}\} \\
& \cup \{i \in [P(n)] \mid g_i = \neg, \mathbf{v}[\mathbf{c}[i][1]] \in \{0, 1\}, \mathbf{v}[i] = \text{Unknown}\} \\
& \cup \{i \in [P(n)] \mid g_i = \text{Input}, \mathbf{v}[i] = \text{Unknown}\}.
\end{aligned} \tag{C.5}$$

Under this notation, we can verify that the optimal policy is given by $\pi^*(s) = \min \tilde{\mathcal{G}}(s)$. Here we omit the subscript and use π^* to represent the optimal policy since $\pi_1^* = \pi_2^* = \dots = \pi_H^*$. Specifically, (i) if the output of the circuit c is 1, the policy π^* can always get the reward 1 and is hence optimal; (ii) if the output of circuit c is 0, the optimal value is 0 and π^* is also optimal. Therefore, our objective is to prove that the computation complexity of π^* falls in AC^0 . Let $\tilde{\Upsilon}[i]$ be the indicator of whether $i \in \tilde{\mathcal{G}}(s)$, i.e. $\tilde{\Upsilon}[i] = 1$ indicates that $i \in \tilde{\mathcal{G}}(s)$ and $\tilde{\Upsilon}[i] = 0$ indicates $i \notin \tilde{\mathcal{G}}(s)$. By the definition of $\tilde{\mathcal{G}}(s)$ in (C.5), we can compute $\tilde{\Upsilon}[i]$ as follows:

$$\begin{aligned}
\tilde{\Upsilon}[i] = & (\mathbb{1}[g_i \in \{\wedge, \vee\}] \wedge \mathbb{1}[\mathbf{v}[\mathbf{c}[i][1]], \mathbf{v}[\mathbf{c}[i][2]] \in \{0, 1\}] \wedge \mathbb{1}[\mathbf{v}[i] = \text{Unknown}]) \\
& \vee (\mathbb{1}[g_i = \neg] \wedge \mathbb{1}[\mathbf{v}[\mathbf{c}[i][1]] \in \{0, 1\}] \wedge \mathbb{1}[\mathbf{v}[i] = \text{Unknown}]) \\
& \vee (\mathbb{1}[g_i = \text{Input}] \wedge \mathbb{1}[\mathbf{v}[i] = \text{Unknown}]).
\end{aligned}$$

Then, we can express the optimal policy as

$$\pi^*(s) = \bigvee_{i \in [P(n)]} (\tilde{\Upsilon}'[i] \wedge i) \quad \text{where } \tilde{\Upsilon}'[i] = \neg \left(\bigvee_{j < i} \tilde{\Upsilon}[j] \right) \wedge \tilde{\Upsilon}[i].$$

Therefore, the computational complexity of the optimal policy falls in AC^0 .

Optimal Value Function. We prove that the computation of the value function of P MDP is P-complete under the log-space reduction. Note that the reward of the P MDP can be only 0 or 1, we consider the decision version of the problem of computing the optimal value function as follows: given a state $s = (\mathbf{x}, \mathbf{c}, \mathbf{v})$ and an action a as input, the goal is determining whether $Q_1^*(s, a) = 1$. we need to prove that this problem belongs to the complexity class P and then provide a log-space reduction from a recognized P-complete problem to this problem.

Step 1. We first verify the problem is in P. According to the definition, a state $s = (\mathbf{x}, \mathbf{c}, \mathbf{v})$ can get the reward 1 if and only if the output of \mathbf{c} is 1. A natural algorithm to compute the value of the circuit \mathbf{c} is computing the values of nodes according to the topological order. This algorithm runs in polynomial time, showing that the target decision problem is in P.

Step 2. Then we prove that the problem is P-complete under the log-space reduction. Under the condition that \mathcal{L} is P-complete, our objective is to provide a log-space reduction from \mathcal{L} to the computation of the optimal value function for the P MDP. By Lemma F.3, a language in P has log-space-uniform circuits of polynomial size. Therefore, there exists a Turing Machine that can generate a description of a circuit \mathbf{c} in log-space which can recognize all strings of length n in \mathcal{L} . Therefore, given any input string \mathbf{x} of length n , we can find a corresponding state $s = (\mathbf{x}, \mathbf{c}, \mathbf{v}_{\text{unknown}})$, where $\mathbf{v}_{\text{unknown}}$ denotes the vector containing $P(n)$ Unknown values. Let $i = \pi^*(s)$, where π^* is the optimal policy defined in the “optimal policy” proof part. Then $\mathbf{x} \in \mathcal{L}$ if and only if $Q_1^*(s, i) = 1$. This provides a desired log-space reduction. We also want to remark that here the size of reduction circuits in L should be smaller than $P(n)$. This condition can be easily satisfied since we can always find a sufficiently large polynomial $P(n)$.

Combining the above two steps, we can conclude that computing the optimal value function is P-complete. \square

D Proofs for Section 5

D.1 State Embeddings and Action Embeddings

Embeddings for the 3-SAT MDP. The state of the n dimension 3-SAT MDP $s = (\psi, \mathbf{v}, k)$. We can use an integer ranging from 1 to $2n$ to represent a literal from $\mathcal{V} = \{u_1, \neg u_1, \dots, u_n, \neg u_n\}$. For example, we can use $(i, i + n)$ to represent $(u_i, \neg u_i)$ for any $i \in [n]$. Therefore, we can use a $3n$ dimensional vector \mathbf{e}_ψ to represent the $\psi \in \mathcal{V}^{3n}$ and a $4n + 1$ dimensional vector $\mathbf{e}_s = (\mathbf{e}_\psi, \mathbf{v}, k)$ to represent the state $s = (\psi, \mathbf{v}, k)$. And we use a scalar to represent the action $a \in \{0, 1\}$.

Embeddings for the NP MDP. The state of the n -dimension NP MDP is denoted as $s = (c, k)$. A configuration of a non-deterministic Turing Machine, represented by c , encompasses the state of the Turing Machine s_M , the contents of the tape t , and the pointer on the tape l . To represent the state of the Turing Machine, the tape of the Turing Machine, and the pointer, we use an integer, a vector of $P(n)$ dimensions, and an integer, respectively. Therefore, a $P(n) + 2$ dimensional vector \mathbf{e}_c is employed to represent the configuration, and a $P(n) + 3$ dimensional vector $\mathbf{e}_s = (\mathbf{e}_c, k)$ is used to represent the state $s = (c, k)$. Additionally, a scalar is utilized to represent the action $a \in \{0, 1\}$.

Embeddings for the CVP MDP. The state of the n -dimension CVP MDP is denoted as $s = (\mathbf{c}, \mathbf{v})$. Utilizing a 3 dimensional vector, we represent a node $\mathbf{c}[i]$ of the circuit. Consequently, a $3n$ dimensional vector $\mathbf{e}_{\mathbf{c}}$ is employed to represent the circuit \mathbf{c} , and a $4n$ dimensional vector $\mathbf{e}_s = (\mathbf{e}_{\mathbf{c}}, \mathbf{v})$ is used to represent the state $s = (\mathbf{c}, \mathbf{v})$. In this representation, an integer ranging from 1 to n is used to signify the node index, an integer ranging from 1 to 5 is employed to denote the type of a node, and an integer ranging from 1 to 3 is utilized to represent the value of a node. Additionally, a scalar is used to represent the action $a \in [n]$.

Embeddings for the P MDP. The state of the n dimensional P MDP is denoted as $s = (\mathbf{x}, \mathbf{c}, \mathbf{v})$. Assuming the upper bound of the size of the circuit is $P(n)$, similar to the previous CVP MDP, a $3P(n)$ -dimension vector $\mathbf{e}_{\mathbf{c}}$ is employed to represent the circuit \mathbf{c} . Meanwhile, a $P(n)$ dimensional vector \mathbf{v} is used to represent the value vector of the circuit, and a n dimensional vector \mathbf{x} represents the input string. In this representation, an integer is used to denote the character of the input, the index of the circuit, the value of a node, or the type of a node. Therefore, a $4P(n) + n$ dimensional vector $\mathbf{e}_s = (\mathbf{x}, \mathbf{e}_{\mathbf{c}}, \mathbf{v})$ is used to represent the state $s = (\mathbf{x}, \mathbf{c}, \mathbf{v})$. Additionally, a scalar is used to represent the action $a \in [P(n)]$.

D.2 Proof of Theorem 5.2

Proof of Theorem 5.2. We show that the model, encompassing both the reward and transition kernel, of both 3-SAT MDPs and NP MDPs can be represented by MLP with constant layers for each respective case.

Reward Function of 3-SAT MDP. First of all, we will prove that the reward function of 3-SAT MDP can be implemented by a constant layer MLP. Denoting the input

$$\mathbf{e}_0 = (\mathbf{e}_s, a) = (\mathbf{e}_{\psi}, \mathbf{v}, k, a),$$

which embeds the state $s = (\psi, \mathbf{v}, k)$ and the action a . For the clarity of presentation, we divide the MLP into three modules and demonstrate each module in detail.

Module 1. The first module is designed to substitute the variable in ψ . Let ψ' be the formula obtained from ψ by substituting all variables and containing only Boolean value. Recall that we use $[2n]$ to represent $\{u_1, \neg u_1, \dots, u_n, \neg u_n\}$. We define a $2n$ dimensional vector $\tilde{\mathbf{v}}$ such that, for any literal $\tau \in \{u_1, \neg u_1, \dots, u_n, \neg u_n\}$, $\tilde{\mathbf{v}}[\tau] = \mathbf{v}[i]$ if $\tau = u_i$ and $\tilde{\mathbf{v}}[\tau] = \neg \mathbf{v}[i]$ if $\tau = \neg u_i$. Hence, given a literal $\tau \in [2n]$, we can get its value $\tilde{\mathbf{v}}[\tau]$ by

$$\tilde{\mathbf{v}}[\tau] = \text{ReLU}\left(\sum_{i \in [n]} \text{ReLU}(\mathbf{v}[i] + \mathbb{1}[\tau = u_i] - 1) + \sum_{i \in [n]} \text{ReLU}(\mathbb{1}[\tau = \neg u_i] - \mathbf{v}[i])\right).$$

According to Lemma F.5, the function $\mathbb{1}[\tau = u_i]$ and $\mathbb{1}[\tau = \neg u_i]$ can be implemented by the constant layer MLP of polynomial size. So we can get the output of Module 1, which is

$$\mathbf{e}_1 = (\mathbf{e}_{\psi'}, \mathbf{v}, k, a).$$

Module 2. The next module is designed to compute the value of ψ' . Given the value of each literal $\alpha_{i,j}$ we can compute the value of ψ' , i.e., $\psi(\mathbf{v})$, by the following formula:

$$\psi(\mathbf{v}) = \text{ReLU}\left(\sum_{i \in [n]} \left(\text{ReLU}(\alpha_{i,1} + \alpha_{i,2} + \alpha_{i,3}) - \text{ReLU}(\alpha_{i,1} + \alpha_{i,2} + \alpha_{i,3} - 1)\right) - n + 1\right).$$

So we can get the output of Module 2, which is

$$\mathbf{e}_2 = (\psi(\mathbf{v}), k, a).$$

Module 3. The last module is designed to compute the final output $r(s, a)$. Given the input $\mathbf{e}_2 = (\psi(\mathbf{v}), k, a)$, we can compute the output $r(s, a)$ by

$$r(s, a) = \mathbb{1}[\psi(\mathbf{v}) \wedge (k = n + 1)] + 0.5 \cdot \mathbb{1}[k = 2n + 2].$$

While the input can take on polynomial types of values at most, according to Lemma F.5, we can use the MLP to implement this function. Therefore, we can use a constant layer MLP with polynomial hidden dimension to implement the reward function of n dimension 3-SAT MDP.

Transition Kernel of 3-SAT MDP. We can use a constant layer MLP with polynomial hidden dimension to implement the transition kernel of 3-SAT MDP. Denote the input

$$\mathbf{e}_0 = (\mathbf{e}_s, a) = (\mathbf{e}_\psi, \mathbf{v}, k, a),$$

which embeds the state $s = (\psi, \mathbf{v}, k)$ and the action a . We only need to modify the embeddings \mathbf{v} and k and denote them as \mathbf{v}' and k' . According to (B.1) in the proof of the transition kernel of Theorem 3.3, we have the output \mathbf{v}' and k of the following form:

$$\begin{aligned} \mathbf{e}'_\psi &= \mathbf{e}_\psi, & \mathbf{v}'[i] &= (\mathbf{v}[i] \wedge \mathbb{1}[i \neq k]) \vee (a \wedge \mathbb{1}[i = k]), \\ k' &= (k + 1) \cdot \mathbb{1}[k \geq 1] + \mathbb{1}[k = 0 \wedge a = 1] + (n + 2) \cdot \mathbb{1}[a = k = 0]. \end{aligned} \tag{D.1}$$

In (D.1), each output element is determined by either an element or a tuple of elements that have polynomial value types at most. Therefore, according to Lemma F.5, each output element can be computed by constant-layer MLP of polynomial size, and the overall output can be represented by a constant layer MLP of polynomial size.

Reward Function of NP MDP. We can use a constant layer MLP with polynomial hidden dimension to implement the reward function of NP MDP. Denote the input

$$\mathbf{e}_0 = (\mathbf{e}_s, a) = (\mathbf{e}_c, k, a),$$

which embeds the state $s = (c, k) = (s_M, \mathbf{t}, l, k)$ and the action a . By (B.2) in the proof of Theorem 3.8, the transition function can be computed by the formula

$$r(s, a) = \mathbb{1}[(s_M = s_{\text{accept}}) \wedge (k = P(n) + 1)] + 0.5 \cdot \mathbb{1}[k = 2P(n) + 2].$$

Therefore, the reward $r(s, a)$ is determined by a tuple (s_M, a, k) , which has polynomial value types at most. According to Lemma F.5, we can compute this function by a constant-layer MLP of polynomial hidden dimension.

Transition Kernel of NP MDP. Finally, we switch to the transition kernel of NP MDP. Denote the input

$$\mathbf{e}_0 = (\mathbf{e}_s, a) = (\mathbf{e}_c, k, a),$$

which embeds the state $s = (c, k) = (s_M, \mathbf{t}, l, k)$ and the action a and denote the dimension of \mathbf{t} is $P(n)$. We obtain the final output in three steps. The first step is to extract the content χ of the location l on the tape by the formula

$$\chi = \bigvee_{i \in [P(n)]} (\mathbf{t}[i] \wedge \mathbb{1}[i = l]).$$

We further convert it to the form in MLP by

$$\chi = \text{ReLU}\left(\sum_{i \in [P(n)]} \chi'_i\right) - \text{ReLU}\left(\sum_{i \in [P(n)]} \chi'_i - 1\right), \quad \text{where } \chi'_i = \mathbf{t}[i] \cdot \mathbb{1}[i = l].$$

Regarding the configuration $c' = (s'_M, \mathbf{t}', l')$ defined in (3.4), we notice that

- (i) the Turing Machine state s'_M is determined by s, a and χ ;
- (ii) the content of the location l on the tape, $\mathbf{t}'[l]$, is determined by s_M, a and χ , whereas the contents of the other locations on the tape remain unaltered, i.e., $t'[i] = t[i]$ for $i \neq k$;
- (iii) the pointer l' is determined by l, s_M, a and χ .

In addition, the number of steps k' is determined by k and a . Therefore, each output element is determined by an element or a tuple of elements having polynomial value types at most. According to Lemma F.5, a constant-layer MLP of polynomial size can compute each output element, and the overall output can be computed by a constant-layer MLP of polynomial size. \square

D.3 Proof of Theorem 5.3

Proof of Theorem 5.3. According to Lemma F.7, the computational complexity of MLP with constant layer, polynomial hidden dimension (in n), and ReLU as the activation function is upper-bounded by TC^0 . On the other hand, according to Theorem 3.3 and Theorem 3.8, the computation of the optimal policy and optimal value function for the 3-SAT MDP and NP MDP is NP-complete. Therefore, the theorem holds under the assumption of $\text{TC}^0 \neq \text{NP}$. \square

D.4 Proof of Theorem 5.4

Proof of Theorem 5.4. We show that the reward function, transition kernel, and optimal policy of both CVP MDPs and P MDPs can be individually represented by MLP with constant layers and polynomial hidden dimension.

Reward Function of CVP MDP. We can use a constant layer MLP with polynomial hidden dimension to implement the reward function of CVP MDP. Denote the input

$$\mathbf{e}_0 = (\mathbf{e}_s, a) = (\mathbf{e}_c, \mathbf{v}, a),$$

which embeds the state $s = (\mathbf{c}, \mathbf{v})$ and the action a . According to the definition, we can represent the reward as

$$r(s, a) = \mathbb{1}[\mathbf{v}[n] = 1].$$

By Lemma F.5, we know that $\mathbb{1}[\mathbf{v}[n] = 1]$ can be represented by a constant-layer MLP with polynomial hidden dimension. Hence, the reward function of CVP MDP can be represented by a constant-layer MLP with polynomial hidden dimension.

Transition Kernel of CVP MDP. We can use a constant layer MLP with polynomial hidden dimension to implement the transition kernel of CVP MDP. Denote the input

$$\mathbf{e}_0 = (\mathbf{e}_s, a) = (\mathbf{e}_c, \mathbf{v}, a),$$

which embeds the state $s = (\mathbf{c}, \mathbf{v})$ and the action a . Given an index i , we can fetch the node i and its value by

$$\begin{aligned} \mathbf{v}[i] &= \sum_{j \in [n]} \alpha_{i,j}, & \text{where } \alpha_{i,j} &= \mathbb{1}[i = j] \cdot \mathbf{v}[j], \\ \mathbf{c}[i] &= \sum_{j \in [n]} \beta_{i,j}, & \text{where } \beta_{i,j} &= \mathbb{1}[i = j] \cdot \mathbf{c}[j]. \end{aligned} \tag{D.2}$$

Then, compute the output of node i and denote it as $\mathbf{o}[i]$. $\mathbf{o}[i]$ is determined by the i -th node c_i and its input, therefore, can be computed by a constant layer MLP with polynomial hidden dimension according to Lemma F.5. Denoting the output as $(\mathbf{e}'_c, \mathbf{v}')$, according to the definition of the transition kernel (4.1), we have

$$\mathbf{e}'_c = \mathbf{e}, \quad \mathbf{v}[i]' = \mathbf{v}[i] \cdot \mathbb{1}[i \neq a] + \mathbf{v}[i] \cdot \mathbb{1}[i = a]$$

Therefore, we can compute the transition kernel of CVP MDP by a constant layer MLP with polynomial hidden dimension.

Optimal Policy of CVP MDP. We prove that the MLP can implement the optimal policy, which is specified in the proof of Theorem 4.2 (Appendix C.1). For the convenience of reading, we present the optimal policy here again. Given a state $s = (\mathbf{c}, \mathbf{v})$, denoting $\mathbf{c}[i] = (\mathbf{c}[i][1], \mathbf{c}[i][2], g_i)$, we define $\mathcal{G}(s)$

$$\begin{aligned} \mathcal{G}(s) &= \{i \in [n] \mid g_i \in \{\wedge, \vee\}, \mathbf{v}[\mathbf{c}[i][1]], \mathbf{v}[\mathbf{c}[i][2]] \in \{0, 1\}, \mathbf{v}[i] = \mathbf{Unknown}\} \\ &\cup \{i \in [n] \mid g_i \in \{\neg\}, \mathbf{v}[\mathbf{c}[i][1]] \in \{0, 1\}, \mathbf{v}[i] = \mathbf{Unknown}\} \\ &\cup \{i \in [n] \mid g_i \in \{0, 1\}, \mathbf{v}[i] = \mathbf{Unknown}\}. \end{aligned} \tag{D.3}$$

The set $\mathcal{G}(s)$ defined in (D.3) denotes the indices for which inputs have been computed, and the output has not been computed. Consequently, the optimal policy $\pi^*(s)$ is expressed as $\pi^*(s) = \min \mathcal{G}(s)$. Subsequently, we aim to demonstrate that a constant-layer MLP with polynomial hidden dimension can compute the optimal policy π^* . Let $\Upsilon[i]$ denote the indicator of whether $i \in \mathcal{G}(s)$, i.e., $\Upsilon[i] = 1$ signifies that $i \in \mathcal{G}(s)$, while $\Upsilon[i] = 0$ denotes that $i \notin \mathcal{G}(s)$. According to (D.3), we can compute $\Upsilon[i]$ depends on the i -th node $\mathbf{c}[i]$, its inputs and output, therefore, can be computed

by a constant-layer MLP with polynomial hidden dimension. Then we can express the optimal policy π^* as:

$$\pi^*(s) = \text{ReLU}\left(\sum_{i \in [n]} \Upsilon'[i]\right), \quad \text{where } \Upsilon'[i] = \text{ReLU}\left(1 - \sum_{j < i} \Upsilon[j]\right).$$

Therefore, we can compute the optimal policy by a constant-layer MLP with polynomial size.

Reward Function of P MDP. Denote the input

$$\mathbf{e}_0 = (\mathbf{e}_s, a) = ((\mathbf{x}, \mathbf{e}_c, \mathbf{v}), a),$$

which embeds the state $s = (\mathbf{x}, c, \mathbf{v})$ and the action a and denote the size of the circuit c as $P(n)$. According to the definition, we have

$$r(s, a) = \mathbb{1}[\mathbf{v}[P(n)] = 1].$$

Owing to Lemma F.5, we can compute the reward function of P MDP by a constant layer MLP with polynomial hidden dimension.

Transition Kernel of P MDP. Denote the input

$$\mathbf{e}_0 = (\mathbf{e}_s, a) = ((\mathbf{x}, \mathbf{e}_c, \mathbf{v}), a),$$

which embeds the state $s = (\mathbf{x}, \mathbf{c}, \mathbf{v})$ and the action a . We can fetch the node i and its value by (D.2). Then we compute the output of node i and denote it as $\mathbf{o}[i]$, where $\mathbf{o}[i]$ is determined by the i -th node $\mathbf{c}[i]$ and its inputs. Hence, by Lemma F.5, $\mathbf{o}[i]$ can be computed by a constant-layer MLP with polynomial hidden dimension. Denoting the output as $(\mathbf{x}', \mathbf{e}'_c, \mathbf{v}')$, together with the definition of the transition kernel in (4.3), we have

$$\mathbf{x}' = \mathbf{x}, \quad \mathbf{e}'_c = \mathbf{e}_c, \quad \mathbf{v}'[i] = \mathbf{v}[i] \cdot \mathbb{1}[i \neq a] + \mathbf{v}[i] \cdot \mathbb{1}[i = a].$$

Therefore, we can compute the transition kernel of P MDP by a constant layer MLP with polynomial hidden dimension.

Optimal Policy of P MDP. We prove that the MLP can efficiently implement the optimal policy in the proof of Theorem 4.4 (Appendix C.2). For completeness, we present the definition of optimal policy here. Given a state $s = (\mathbf{x}, \mathbf{c}, \mathbf{v})$, denoting $\mathbf{c}[i] = (\mathbf{c}[i][1], \mathbf{c}[i][2], g_i)$, let $\tilde{\mathcal{G}}(s)$ be a set defined by:

$$\begin{aligned} \tilde{\mathcal{G}}(s) = & \{i \in [P(n)] \mid g_i \in \{\wedge, \vee\}, \mathbf{v}[\mathbf{c}[i][1]], \mathbf{v}[\mathbf{c}[i][2]] \in \{0, 1\}, \mathbf{v}[i] = \text{Unknown}\} \\ & \cup \{i \in [P(n)] \mid g_i = \neg, \mathbf{v}[\mathbf{c}[i][1]] \in \{0, 1\}, \mathbf{v}[i] = \text{Unknown}\} \\ & \cup \{i \in [P(n)] \mid g_i = \text{Input}, \mathbf{v}[i] = \text{Unknown}\}. \end{aligned} \quad (\text{D.4})$$

The set $\tilde{\mathcal{G}}(s)$ defined in (D.4) denotes the indices for which inputs have been computed, and the output has not been computed. With this set, the optimal policy $\pi^*(s)$ is expressed as $\pi^*(s) = \min \tilde{\mathcal{G}}(s)$. Subsequently, we aim to demonstrate that a constant-layer MLP with polynomial hidden

dimension can compute the optimal policy π^* . Let $\tilde{\Upsilon}[i]$ denote the indicator of whether $i \in \tilde{\mathcal{G}}(s)$, i.e., $\tilde{\Upsilon}[i] = 1$ signifies that $i \in \tilde{\mathcal{G}}(s)$, while $\tilde{\Upsilon}[i] = 0$ denotes that $i \notin \tilde{\mathcal{G}}(s)$. Using (D.4), the computation of $\tilde{\Upsilon}[i]$ depends on the i -th node c_i , its inputs, and output. This observation, together with Lemma F.5, allows for the computation through a constant-layer MLP with polynomial hidden dimension. Employing this notation, we can formulate the following MLP expression for the optimal policy π^* :

$$\pi^*(s) = \text{ReLU}\left(\sum_{i \in [P(n)]} \tilde{\Upsilon}'[i]\right), \quad \text{where } \tilde{\Upsilon}'[i] = \text{ReLU}\left(1 - \sum_{j < i} \tilde{\Upsilon}[j]\right).$$

Therefore, the optimal policy of P MDP can be represented by a constant-layer MLP with polynomial hidden dimension. \square

D.5 Proof of Theorem 5.5

Proof of Theorem 5.5. By Lemma F.7, we have that the computational complexity of MLP with constant layer, polynomial hidden dimension (in n), and ReLU as the activation function is upper-bounded by TC^0 . On the other hand, by Theorem 4.2 and 4.4, the computation of the optimal value Function of CVP MDP and P MDP is P-complete. Therefore, we conclude the proof under the assumption of $\text{TC}^0 \neq \text{P}$. \square

E Extension to Stochastic MDPs

In this section, we demonstrate how our construction of the 3-SAT MDP, NP MDP, CVP MDP, and P MDP can be seamlessly extended to their stochastic counterparts. We offer a detailed extension of the 3-SAT MDP to its stochastic version and outline the conceptual approach for extending other types of MDPs to their stochastic counterparts.

Stochastic 3-SAT MDP. First, we add some randomness to the transition kernel and reward function. Moreover, to maintain the properties in Theorem 3.3, Theorem 5.3, and Theorem 5.2 of 3-SAT MDP, we slightly modify the action space and extend the planning horizon.

Definition E.1 (Stochastic 3-SAT MDP). For any $n \in \mathbb{N}_+$, let $\mathcal{V} = \{u_1, \neg u_1, \dots, u_n, \neg u_n\}$ be the set of literals. An n -dimensional stochastic 3-SAT MDP $(\mathcal{S}, \mathcal{A}, H, \mathcal{P}, r)$ is defined as follows. The state space \mathcal{S} is defined by $\mathcal{S} = \mathcal{V}^{3n} \times \{0, 1, \text{Next}\}^n \times (\{0\} \cup [n + 2])$, where each state s can be denoted as $s = (\psi, \mathbf{v}, k)$. In this representation, ψ is a 3-CNF formula consisting of n clauses and represented by its $3n$ literals, $\mathbf{v} \in \{0, 1\}^n$ can be viewed as an assignment of the n variables and k is an integer recording the number of actions performed. The action space is $\mathcal{A} = \{0, 1\}$ and the planning horizon is $H = n^2 + n + 2$. Given a state $s = (\psi, \mathbf{v}, k)$, for any $a \in \mathcal{A}$, the reward $r(s, a)$ is defined by:

$$r(s, a) = \begin{cases} 1 & \text{If } \mathbf{v} \text{ is a satisfiable assignment of } \psi, k = n + 1 \text{ and } a = \text{Next}, \\ \frac{1}{2} & \text{If } k = n^2 + 2n + 2, \\ 0 & \text{Otherwise.} \end{cases} \quad (\text{E.1})$$

Moreover, the transition kernel is stochastic and takes the following form:

$$\mathcal{P}((\psi, \mathbf{v}, k), a) = \begin{cases} (\psi, \mathbf{v}, n+2) & \text{If } a = k = 0, \\ (\psi, \mathbf{v}, 1) & \text{If } a = 1 \text{ and } k = 0, \\ (\psi, \mathbf{v}, k+1) & \text{If } a = \text{Next}, \\ (\psi, \mathbf{v}', k) & \text{If } k \in [n] \text{ and } a \in \{0, 1\} \\ (\psi, \mathbf{v}, k) & \text{If } k > n \text{ and } a \in \{0, 1\}, \end{cases} \quad (\text{E.2})$$

where \mathbf{v}' is obtained from \mathbf{v} by setting the k -th bit as a with probability $\frac{2}{3}$ and as $1 - a$ with probability $\frac{1}{3}$, and leaving other bits unchanged, i.e.,

$$\mathbf{v}'[k] = \begin{cases} a & \text{with probability } \frac{2}{3} \\ 1 - a & \text{with probability } \frac{1}{3} \end{cases} \quad \mathbf{v}'[k'] = \mathbf{v}[k'] \text{ for } k' \neq k.$$

Given a 3-CNF formula ψ , the initial state of the 3-SAT MDP is $(\psi, \mathbf{0}_n, 0)$.

Theorem E.2 (Representation complexity of Stochastic 3-SAT MDP). Let \mathcal{M}_n be the n -dimensional stochastic 3-SAT MDP in Definition E.1. The transition kernel \mathcal{P} and the reward function r of \mathcal{M}_n can be computed by circuits with polynomial size (in n) and constant depth, falling within the circuit complexity class AC^0 . However, computing the optimal value function Q_1^* and the optimal policy π^* of \mathcal{M}_n are both NP-hard under the polynomial time reduction.

Proof of Theorem E.2. We investigate the representation complexity of the reward function, transition kernel, optimal value function, and optimal policy in sequence.

Reward Function. The reward function is the same as the deterministic version, therefore, we can apply the proof of Theorem 3.3 and conclude that the complexity of the reward function falls in AC^0 .

Transition Kernel. Then, we will implement the transition kernel by AC^0 circuits. Slightly different from the deterministic version, in this case, the input of the transition kernel \mathcal{P} are two states $s = (\psi, \mathbf{v}, k), s' = (\psi', \mathbf{v}', k')$ and action a , and the output is the probability of transition from s to s' . Given the input $\mathbf{v}, k, \mathbf{v}', k'$ and a , we have the output as follows:

- The output is 1 if the input satisfies the following four equations:

$$\begin{aligned} a = \text{Next}, \quad \mathbf{v} = \mathbf{v}', \quad \psi = \psi', \\ k' = (k+1) \cdot \mathbb{1}[k \geq 1] + \mathbb{1}[k = 0 \wedge a = 1] + (n+2) \cdot \mathbb{1}[a = k = 0]. \end{aligned}$$

- The output is $\frac{2}{3}$ if the input satisfies the following four equations:

$$a \in \{0, 1\}, \quad k = k', \quad \psi = \psi', \quad \mathbf{v}'[i] = (\mathbf{v}[i] \wedge \mathbb{1}[i \neq k]) \vee (a \wedge \mathbb{1}[i = k]).$$

- The output is $\frac{1}{3}$ if the input satisfies the following four equations:

$$a \in \{0, 1\}, \quad k = k', \quad \psi = \psi', \quad \mathbf{v}'[i] = \neg(\mathbf{v}[i] \wedge \mathbb{1}[i \neq k]) \vee (a \wedge \mathbb{1}[i = k]).$$

- The output is 0 otherwise.

It is noted that each element in the previous equations is determined by at most $O(\log n)$ bits. Therefore, according to Lemma F.4, the condition judgments can be computed by two-layer circuits of polynomial size, and the overall output can be computed by AC^0 circuits.

Optimal Value Function. Next, we will prove the NP-hardness of computing the optimal value function. Similar to the optimal value function part of the proof of Theorem 3.3, we formulate a simpler decision version of this problem: given a state $s = (\psi, \mathbf{v}, k)$, an action a and a number γ as input, and the goal is to determine whether $Q_1^*(s, a) > \frac{1}{2}$. According to the well-known Cook-Levin theorem (Lemma F.1), the 3-SAT problem is NP-complete. Thus, our objective is to provide a polynomial time reduction from the 3-SAT problem to the computation of the optimal value function for the 3-SAT MDP. Given a Boolean formula of length n , the number of variables is at most n . Then, we can pad several meaningless clauses such as $(u_1 \vee \neg u_1 \vee u_1)$ to obtain the 3-CNF Boolean formula ψ' with n clauses. When the Boolean formula ψ is not satisfiable, the value of $Q_1^*((\psi', \mathbf{0}_n), 1)$ is 0. When the Boolean formula ψ is satisfiable, we will prove that the probability of the reward 1 is higher than $\frac{1}{2}$. Note that, when ψ is satisfiable, we only need to modify the values of the variables at most n times to get a satisfiable assignment in the deterministic case. In the stochastic case, we have n^2 chances to modify the value of a variable with a success probability of $\frac{2}{3}$, and to get the reward, we only need n times success. Therefore, we can compute the probability of getting the reward as

$$\Pr(n \text{ times success in } n^2 \text{ chances}) \geq \left(\Pr(\text{one success in } n \text{ chances}) \right)^n = \left(1 - \frac{1}{3^n} \right)^n > \frac{1}{2}. \quad (\text{E.3})$$

Therefore, ψ is satisfiable if and only if $Q_1^*((\psi', \mathbf{0}_n), 1) > \frac{1}{2}$, we can conclude that computing the optimal value function is NP-hard.

Optimal Policy. Finally, we will prove that the problem of computing the optimal policy is NP-hard. According to the well-known Cook-Levin theorem (Lemma F.1), the 3-SAT problem is NP-complete. Thus, our objective is to provide a polynomial time reduction from the 3-SAT problem to the problem of computing the optimal policy of 3-SAT MDP. Given a Boolean formula of length n , the number of variables is at most n . Then, we can pad several meaningless clauses such as $(u_1 \vee \neg u_1 \vee u_1)$ to obtain the 3-CNF Boolean formula ψ' with n clauses. When the Boolean formula ψ is satisfiable, according to (E.3), we have

$$Q_1^*((\psi', \mathbf{0}_n), 1) > 0.7 > Q_1^*((\psi', \mathbf{0}_n), 0),$$

which gives that $\pi^*(\psi', \mathbf{0}_n, 0) = 1$. When the Boolean formula ψ is not satisfiable, we have

$$Q_1^*((\psi', \mathbf{0}_n), 1) = 0 < Q_1^*((\psi', \mathbf{0}_n), 0),$$

which implies that $\pi^*(\psi', \mathbf{0}_n, 0) = 0$. So the Boolean formula ψ is satisfiable if and only if $\pi^*(\psi', \mathbf{0}_n, 0) = 1$, which concludes that the problem of computing the optimal policy is NP-hard. \square

Almost the same as the stochastic version of 3-SAT MDP, we can construct the stochastic version NP MDP. And under the assumption of $\mathcal{L} \in \text{NP}$, the same theorem as Theorem E.2 will

hold. More exactly, the complexity of the transition kernel and the reward function of the MDP based on \mathcal{L} fall in AC^0 , and the complexity of the optimal policy and optimal value function are NP-hard. Moreover, similar to the case of the stochastic version of 3-SAT MDP, we add some randomness to the transition function of CVP MDP and P MDP. In the deterministic version of the transition function, given the action i , we will compute the value of the i -th node. In contrast, the computation of the value of i -th node will be correct with the probability of $\frac{2}{3}$ and will be incorrect with the probability of $\frac{1}{3}$. And we extend the planning horizon to $O(n^2)$ or $O(P(n)^2)$. Then we can get similar conclusions as Theorems 4.2 and 4.4. To avoid repetition, we only provide the construction and corresponding theorem of stochastic CVP and omit the proof and the detailed extension to stochastic P MDPs.

Definition E.3 (Stochastic CVP MDP). An n -dimensional Stochastic CVP MDP is defined as follows. Let \mathcal{C} be the set of all circuits of size n . The state space \mathcal{S} is defined by $\mathcal{S} = \mathcal{C} \times \{0, 1, \text{Unknown}\}^n$, where each state s can be represented as $s = (\mathbf{c}, \mathbf{v})$. Here, \mathbf{c} is a circuit consisting of n nodes with $\mathbf{c}[i] = (\mathbf{c}[i][1], \mathbf{c}[i][2], g_i)$ describing the i -th node, where $\mathbf{c}[i][1]$ and $\mathbf{c}[i][2]$ indicate the input node and g_i denotes the type of gate (including $\wedge, \vee, \neg, 0, 1$). When $g_i \in \{\wedge, \vee\}$, the outputs of $\mathbf{c}[i][1]$ -th node and $\mathbf{c}[i][2]$ -th node serve as the inputs; and when $g_i = \neg$, the output of $\mathbf{c}[i][1]$ -th node serves as the input and $\mathbf{c}[i][2]$ is meaningless. Moreover, the node type of 0 or 1 denotes that the corresponding node is a leaf node with a value of 0 or 1, respectively, and therefore, $\mathbf{c}[i][1], \mathbf{c}[i][2]$ are both meaningless. The vector $\mathbf{v} \in \{0, 1, \text{Unknown}\}^n$ represents the value of the n nodes, where the value **Unknown** indicates that the value of this node has not been computed and is presently unknown. The action space is $\mathcal{A} = [n]$ and the planning horizon is $H = n + 1$. Given a state-action pair $(s = (\mathbf{c}, \mathbf{v}), a)$, its reward $r(s, a)$ is given by:

$$r(s, a) = \begin{cases} 1 & \text{If } \mathbf{v} \text{ contains correct value of the } n \text{ gates and the value of the output gate } \mathbf{v}[n] = 1, \\ 0 & \text{Otherwise.} \end{cases}$$

Moreover, the transition kernel is deterministic and can be defined as follows:

$$\mathcal{P}((\mathbf{c}, \mathbf{v}), a) = (\mathbf{c}, \mathbf{v}').$$

Here, \mathbf{v}' is obtained from \mathbf{v} by computing and substituting the value of node a with the probability of $\frac{2}{3}$. More exactly, if the inputs of node a have been computed, we can compute the output of the node a and denote it as $\mathbf{o}[a]$. Let $\tilde{\mathbf{o}}[a]$ be a random variable getting value of $\mathbf{o}[a]$ with probability of $\frac{2}{3}$ and getting value of **Unknown** with probability of $\frac{1}{3}$. Then we have

$$\mathbf{v}'[j] = \begin{cases} \mathbf{v}[j] & \text{If } a \neq j, \\ \tilde{\mathbf{o}}[a] & \text{If } a = j \text{ and the inputs of node } a \text{ have been computed,} \\ \text{Unknown} & \text{If } a = j \text{ and the inputs of node } a \text{ have not been computed.} \end{cases}$$

Given a circuit \mathbf{c} , the initial state of CVP MDP is $(\mathbf{c}, \mathbf{v}_{\text{unknown}})$ where $\mathbf{v}_{\text{unknown}}$ denotes the vector containing n **Unknown** values.

Theorem E.4 (Representation complexity of Stochastic CVP MDP). Let \mathcal{M}_n be the n -dimensional stochastic CVP MDP in Definition E.1. The transition kernel \mathcal{P} , the reward function r , and the optimal policy π^* of \mathcal{M}_n can be computed by circuits with polynomial size (in n) and constant depth, falling within the circuit complexity class AC^0 . However, computing the optimal value function Q_1^* of \mathcal{M}_n are P-hard under the log space reduction.

F Auxiliary Lemmas

Lemma F.1 (Cook-Levin Theorem (Cook, 1971; Levin, 1973)). The 3-SAT problem is NP-complete.

Lemma F.2 (P-completeness of CVP (Ladner, 1975)). The CVP is P-complete.

Lemma F.3 (Theorem 6.5 in Arora and Barak (2009)). A language has log-space-uniform circuits of polynomial size if and only if it is in P.

Lemma F.4 (Implement Any Boolean Function). For every Boolean function $f : \{0, 1\}^l \rightarrow \{0, 1\}$, there exists a two layer circuit \mathbf{c} of size $\mathcal{O}(l \cdot 2^l)$ such that $\mathbf{c}(\mathbf{u}) = f(\mathbf{u})$ for all $\mathbf{u} \in \{0, 1\}^l$.

Proof. For every $\mathbf{v} \in \{0, 1\}^l$, let

$$\mathbf{c}_{\mathbf{v}}(\mathbf{u}) = \bigwedge_{i \in [n]} g_{\mathbf{v}[i]}(\mathbf{u}_i),$$

where $g_0(\mathbf{u}[i]) = \neg \mathbf{u}[i]$ and $g_1(\mathbf{u}[i]) = \mathbf{u}[i]$. Then we have $\mathbf{c}_{\mathbf{v}}(\mathbf{u}) = 1$ if and only if $\mathbf{u} = \mathbf{v}$. When there exists $\mathbf{u} \in \{0, 1\}^l$ such that $f(\mathbf{u}) = 1$, we can construct the two-layer circuit as

$$\mathbf{c}(\mathbf{u}) = \bigvee_{\mathbf{v} \in \{\mathbf{v} | f(\mathbf{v})=1\}} (\mathbf{c}_{\mathbf{v}}(\mathbf{u})).$$

By definition, we can verify that $f(\mathbf{u}) = \mathbf{c}(\mathbf{u})$ for any $\mathbf{u} \in \{0, 1\}^l$. When $f(\mathbf{u}) = 0$ for all $\mathbf{u} \in \{0, 1\}^l$, we can construct the circuit as $\mathbf{c}(\mathbf{u}) = 0$. Therefore, for every Boolean function $f : \{0, 1\}^l \rightarrow \{0, 1\}$, there exists a two-layer circuit \mathbf{c} of size $\mathcal{O}(l \cdot 2^l)$ such that $\mathbf{c}(\mathbf{u}) = f(\mathbf{u})$ for all $\mathbf{u} \in \{0, 1\}^l$, which concludes the proof of Lemma F.4. \square

Lemma F.5 (Looking-up Table for MLP). For any function $f : \mathcal{X} \rightarrow \mathbb{R}$, where \mathcal{X} is a finite subset of \mathbb{R}^l , there exists a constant-layer MLP f_{MLP} with hidden dimension $\mathcal{O}(l \cdot |\mathcal{X}|)$ such that $f_M(\mathbf{x}) = f(\mathbf{x})$ for all $\mathbf{x} \in \mathcal{X}$.

Proof. Denote the minimum gap between each pair of elements in \mathcal{X} by δ_{\min} , i.e.,

$$\delta_{\min} = \min_{\mathbf{u}, \mathbf{v} \in \mathcal{X}} \|\mathbf{u} - \mathbf{v}\|_{\infty}.$$

For each $\mathbf{u} \in \mathcal{X}$, we can construct an MLP as

$$f_{\mathbf{u}}(\mathbf{x}) = \text{ReLU}\left(\sum_{i \in [l]} f_{\mathbf{u}, i}(\mathbf{x}) - (l - 1) \cdot \delta_{\min}\right),$$

where

$$f_{\mathbf{u},i}(\mathbf{x}) = \text{ReLU}\left(2\delta_{\min} - 2 \cdot \text{ReLU}(\mathbf{x}[i] - \mathbf{u}[i]) - \text{ReLU}(\mathbf{u}[i] - \mathbf{x}[i] + \delta_{\min})\right).$$

We have

$$f_{\mathbf{u}}(\mathbf{x}) = \begin{cases} \delta_{\min} & \text{If } \mathbf{x} = \mathbf{u}, \\ 0 & \text{If } \mathbf{x} \in \mathcal{X} \setminus \{\mathbf{u}\}. \end{cases}$$

Then we can construct the MLP f_{MLP} as

$$f_{\text{MLP}}(\mathbf{x}) = \sum_{\mathbf{u} \in \mathcal{S}} \left(\frac{f_{\mathbf{u}}(\mathbf{x})}{\delta_{\min}} \cdot f(\mathbf{u}) \right).$$

It is easy to verify that $f_{\text{MLP}}(\mathbf{x}) = f(\mathbf{x})$ for all $\mathbf{x} \in \mathcal{X}$, which concludes the proof of Lemma F.5. \square

Lemma F.6 (MLP can Implement Basic Gates in TC^0). Given $\mathbf{x} \in \{0, 1\}^n$ as input, constant-layer MLPs can implement the following basic operation functions:

- AND: $f_{\text{AND}}(\mathbf{x}) = \bigwedge_{i \in [n]} \mathbf{x}[i]$;
- OR: $f_{\text{OR}}(\mathbf{x}) = \bigvee_{i \in [n]} \mathbf{x}[i]$;
- NOT: $f_{\text{NOT}}(\mathbf{x}[1]) = 1 - \mathbf{x}[1]$;
- Majority: $f_{\text{MAJ}}(\mathbf{x}) = \mathbb{1}[\sum_{i \in [n]} \mathbf{x}[i] > \frac{n}{2}]$.

Proof. We express the four functions in the MLP forms as follows:

- $f_{\text{AND}}(\mathbf{x}) = \text{ReLU}(\sum_{i \in [n]} \mathbf{x}[i] - n + 1)$;
- $f_{\text{OR}}(\mathbf{x}) = 1 - \text{ReLU}(1 - \sum_{i \in [n]} \mathbf{x}[i])$;
- $f_{\text{NOT}}(\mathbf{x}[1]) = 1 - \mathbf{x}[1]$;
- $f_{\text{MAJ}}(\mathbf{x}) = \text{ReLU}(2 \cdot \sum_{i \in [n]} \mathbf{x}[i] - n) - \text{ReLU}(2 \cdot \sum_{i \in [n]} \mathbf{x}[i] - n - 1)$.

Therefore, the basic gates of TC^0 can be implemented by constant-layer MLPs with ReLU as the activation function. \square

Lemma F.7 (Upper Bound of Expressive Power for MLP). Any log-precision MLP with constant layers, polynomial hidden dimension (in the input dimension), and ReLU as the activation function can be simulated by a L -uniform TC^0 circuits.

Proof. In the previous work by Merrill and Sabharwal (2023), it was demonstrated that a Transformer with logarithmic precision, a fixed number of layers, and a polynomial hidden dimension can be simulated by a L -uniform TC^0 circuit. The proof presented by Merrill and Sabharwal (2023) established the validity of this result specifically when the Transformer employs standard activation functions (e.g., ReLU, GeLU, and ELU) in the MLP. Considering that the MLP can be perceived as a submodule of the Transformer, it follows that a log-precision MLP with a consistent number of layers, polynomial hidden dimension, and ReLU as the activation function can be simulated by a L -uniform TC^0 circuit. \square