

# CRNNet: Copy Recurrent Neural Network Structure Network

Xiaofan Zhou<sup>1</sup> and Xunzhu Tang<sup>2</sup>

<sup>1</sup> Worcester Polytechnic Institute, Worcester MA 01609, USA

<sup>2</sup> University of Luxembourg, Luxembourg

**Abstract.** The target of Electronic Health Record (EHR) coding is to find the diagnostic codes according to the EHRs. In previous research, researchers have preferred to do multi-classification on the EHR coding task; most of them encode the EHR first and then process it to get the probability of each code based on the EHR representation. However, the question of complicating diseases is neglected among all these methods. In this paper, we propose a novel EHR coding framework, which is the first attempt at detecting complicating diseases, called Copy Recurrent Neural Network Structure Network (CRNNet). This method refers to the idea of adversarial learning; a Path Generator and a Path Discriminator are designed to more efficiently finish the task of EHR coding. We propose a copy module to detect complicating diseases; by the proposed copy module and the adversarial learning strategy, we identify complicating diseases efficiently. Extensive experiments show that our method achieves a 57.30% ratio of complicating diseases in predictions, demonstrating the effectiveness of our proposed model. According to the ablation study, the proposed copy mechanism plays a crucial role in detecting complicating diseases.

**Keywords:** EHR coding· Path generation· Adversarial learning· Recurrent Neural Networks.

## 1 Introduction

In the contemporary era of healthcare, the abundance of biomedical data has increasingly become crucial, making coding for Electronic Health Records (EHR) a significant task [19]. EHR coding is a classification task that generates International Classification of Diseases (ICD) codes for EHRs, which plays a crucial role in various areas, e.g., search, data mining, billing, epidemiology, and disease detection for healthcare manufacturers [1,6]. Deep learning methods for EHR coding are popular due to their higher accuracy and ability to handle large volumes of data efficiently within a short time frame.

EHR coding remains a challenging task today, and multi-label classification has been the main trend in recent years' research on the EHR coding task [13,22]. Among these methods, deep learning techniques, e.g., multilayer perceptron (MLP) [23], and sequential models like long short-term memory and

recurrent neural networks [18,10], generate probabilities for each code. Codes with probabilities higher than a threshold are then used as labels for the EHRs. However, these methods face several shortcomings. Firstly, codes exist in a very high-dimensional space; in ICD-9-CM, there are more than 18,000 codes, and these codes have a severely unbalanced distribution. Secondly, existing methods often neglect the fact that some codes may form a group of complications; their only target is to classify the codes directly. For example, people with diabetes mellitus may also have diabetic retinopathy and cataracts caused by diabetes. Moreover, determining the appropriate threshold in these methods is challenging. A second family of EHR coding methods generates a path where the code in this path is treated as the classification result for the EHR. This approach, called RPGNet, reduces the candidate space of ICD codes and uses each node as a prediction result for EHRs [26]. However, this method still cannot effectively address the problem of identifying complicating diseases.

In this paper, we concentrate on EHR coding methods aimed at identifying groups of complicating diseases. To detect these complicating diseases, our new method generates ICD codes using Recurrent Neural Networks (RNNs). We employ the odds ratio to evaluate whether two nodes might be complications. Subsequently, we use existing ICD codes to generate new ICD codes based on their complication information. This formulation allows for the discovery of ICD codes that are based on complication information. Furthermore, each output in the RNN can be considered as a prediction result, enabling the RNN method to be used for multi-label prediction without the need to determine a threshold for labels.

## 2 RELATED WORK

### 2.1 Automatic EHRs coding

Deep learning has been proven efficient in various fields. The field of automatic EHR coding has recently seen a surge in publications, encompassing a range of approaches and techniques. Several recent studies address this question using sequential models. Li and Yu leverage a residual structure and a series of convolutional layers to extract more efficient representations for EHRs [16]. [6] and [3] used recurrent neural networks (RNNs) to extract the representation of EHRs.

Other works introduce medical knowledge into EHR coding. To utilize the information from the ICD code definitions, they encode the descriptions provided by medical workers for the ICD codes for more efficient representation through CNNs and RNNs [22,20]. Additionally, [27] proposed a tree-of-sequences LSTM model that can capture both the semantics of each code and the hierarchical relationships of codes. [24] introduced various methods to leverage the hierarchical knowledge of ICD codes by adding refined loss functions.

Recently, the RAC model [14] proposed a Read, Attend, and Code (RAC) framework that can predict ICD codes more efficiently, greatly improving the task. In JointLAAT [25], a developed label-aware attention mechanism is leveraged

in a bidirectional LSTM. Hypercore [4] considers the hierarchical structure as a hyperbolic space and leverages a graph-based neural network to capture co-occurrences of codes. ISD [31] proposes a self-distillation learning mechanism to alleviate the long-tail code distribution and uses shared representation extraction for codes of different frequencies. EffectiveCAN [17] developed a network with a squeeze-and-excitation (SE) mechanism connected by residual connections and extracted representations from all encoder layers for label attention. They also introduced focal loss to address data imbalance issues. However, these recent models aim to find the relationship between EHR representations and code representations. In contrast, our work emphasizes the relationship between the codes, applying a copy module to identify complicating diseases.

## 2.2 Adversarial learning in healthcare

Generative Adversarial Networks (GANs) have demonstrated impressive results in generative tasks, especially in computer vision. A GAN comprises a discriminator and a generator, where the generator creates outputs to deceive the discriminator, and the discriminator is designed to classify which outputs are from the generator and which are from the ground truth. In the healthcare domain, various GAN models have excelled in Electronic Health Record (EHR) tasks. RGAN and RCGAN [8] generate realistic time-series data, while medGAN [7] and mtGAN [11] produce convincing EHRs. Furthermore, [29] deals with rare disease detection using semi-supervised GANs.

Distinct from previous research, our approach employs seqGAN concepts [30], integrating GAN with LSTM to generate multi-label outputs and calculate rewards for every generated path. The discriminator evaluates the legitimacy of the path, using the outcomes as rewards for each generated path, thereby guiding our model’s learning process.

## 3 METHOD

The aim of this study is to formulate a series of diagnostic codes, denoted as  $Y = [c^1, c^2, \dots, c^j, \dots]$ , which correspond to Electronic Health Records (EHRs). Each  $c^i$  in this series signifies an International Classification of Diseases (ICD) code and where  $i$  means the position of code in the path, and  $c^i \in C$ , where  $C$  represents code dictionary. For the sake of simplification, we treat an EHR, denoted as  $x$ , as unstructured text. In mathematical terms,  $x = [w_1, w_2, \dots, w_i, \dots]$ , where  $w_i \in W$ ,  $W$  is the words token dictionary. The methods we propose to achieve this objective will be elaborated in the subsequent sections of this paper.

### 3.1 Overview

In CRNNet, there are two crucial parts, the first part is a path generator  $G_\theta$ , the path generator is used to generate a list of ICD paths, the ICD paths will be seen as the classification result for the given EHR  $x$ , in the path generator  $G_\theta$ ,

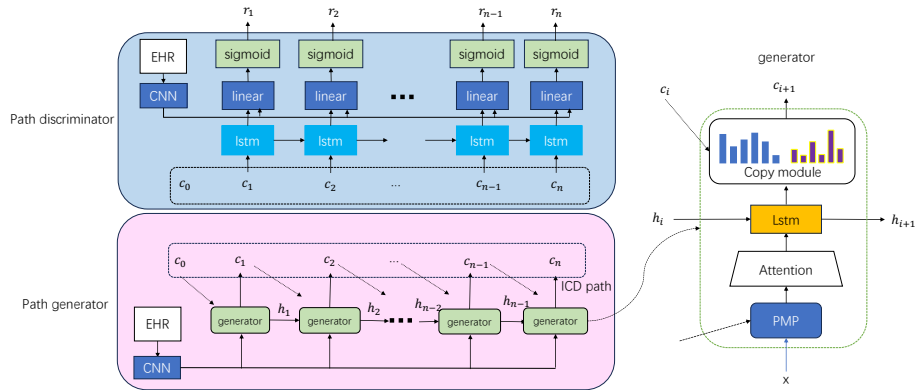

**Fig. 1.** Overview of CRNNet

firstly, a EHR encoder generate a feature representation using convolutional neural network and a token embedding matrix  $I^{n \times d}$  where  $n$  represents the count of the token while  $d$  represents embedding matrix's dimension. Then, we propose a EHR-ICD fusion module, to combine the information of previous generated code, EHR embedding. To consider the long-short term relation, we leverage LSTM module to generate the probability of every code at each timestamp and choose the code with largest probability as the code at each timestamp, finally, a copy module is used to help with finding the complication disease based on the preceding code  $c_{t-1}$ . We use the probability given by LSTM and copy module as the classification result. The length of LSTM is a preset hyper-parameter.

To classify whether the code path generated by the path generator  $G_\theta$  is a feasible code path, we apply the idea of GAN to design a path discriminator  $D_\phi$ , which output a probability score  $r_t$ ,  $r_t$  means the probability of truth of the generated path. The input of  $D_\phi$  is the embedding of EHR  $x$ , and the ICD path is generated by path generator  $G_\theta$ . By the way, we split the ICD path generated by path generator  $G_\theta$  into  $t$  parts, where  $t$  is the valid codes number in the path, so that we can enlarge the sample number fed into the  $D_\phi$ . This path discriminator helps to better train the path generator, and updated in a certain round.

### 3.2 Long Short Term Memory Networks (LSTM)

Recurrent Neural Network (RNN) architecture the main part of the path generator, specialized for processing sequential data. Unlike traditional feedforward neural networks, RNNs are designed with interconnected hidden states that allow them to capture dynamic temporal patterns within sequences. Conceptually, they can be thought of as an advancement over hidden Markov models, but with the incorporation of nonlinear transition functions. This structure makes RNNs particularly adept at identifying long-range temporal dependencies. Compared

to other RNNs, Long Short-Term Memory (LSTM) networks is special. Each neuron in LSTMs contains three gates: input  $i$ , forget  $f$ , and output  $o$ . These gating mechanisms bestow LSTMs with three distinct advantages: firstly, they excel in learning long-term sequence dependencies; secondly, they facilitate easier optimization, as the gates effectively route the input signal through recurrent hidden states  $r(t)$  without causing undesired alterations in the output; and thirdly, they mitigate the well-known exploding and vanishing gradient encountered during the training of conventional RNNs.

The mathematical representation of the LSTM is given by:

$$\begin{aligned}
 f_t &= \sigma(W_f \cdot [h_{t-1}, c_t] + b_f) \\
 i_t &= \sigma(W_i \cdot [h_{t-1}, c_t] + b_i) \\
 \tilde{C}_t &= \text{relu}(W_C \cdot [h_{t-1}, c_t] + b_C) \\
 C_t &= f_t \times C_{t-1} + i_t \times \tilde{C}_t \\
 o_t &= \sigma(W_o \cdot [h_{t-1}, c_t] + b_o) \\
 h_t &= o_t \times \tanh(C_t)
 \end{aligned} \tag{1}$$

$\sigma$  denotes sigmoid function,  $\cdot$  represents element-wise product, and the  $W_*$  matrix is weight matrix,  $b_*$  is bias vector,  $h_{t-1}$  represents hidden representation before. In this paper, rectified linear units (ReLU) us used for activation function.

### 3.3 Path generator $G_\theta$

The path generator is contituted by four parts: we first get the representation  $x$  by multichannel CNN encoder from raw text, then we use PMP to consider the connection between the codes in the path and get  $v$  as representation, after put the  $v$  into lstm, then we use the former code in the path  $c$  and  $o$  into the copy module to get the final codes which can help with finding the complications. We will introduce this progress step by step.

**EHR-ICD fusion module** We use the EHR-ICD fusion module to process the hidden state  $h_t$  obtained from LSTM by considering the relationship between EHR  $x$  and the generated Codes path, the relationship between the current code and all other codes. Next, we will talk about how EHR-ICD fusion module is used to address the question.

*relationship between EHR and the generated Codes path* In this step, we fuse the representation of EHR  $x$  and the representation of generated code path, and we represent the result in this step as  $o_t$ , which is shown below:

$$o_t = \tanh(W_o(u_t)) \tag{2}$$

where  $W_o$  is weight matrix and  $u_t$  is calculated by a series of operation on the representation of  $x$  and  $o_t$ , such operation is shown below:

$$u_t = x \oplus c_t \oplus (x \odot c_t) \oplus (x + c_t) \oplus (x - c_t) \oplus (c_t - x) \tag{3}$$

The  $\oplus$  represents concatenation operation,  $\odot$  represents product.

*Former-to-later code relationship* This part aims to capture the relationship of previous ICD codes  $c_{t-1}$  and subsequent ICD codes  $c_t$ . To find the how generated code and all codes in relation, we use the  $u_t$  generated by considering the relationship between an EHR and the generated Codes path as input, we use the representation of all codes to do the task before:

$$v_t = o_t \cdot c_t^c \quad (4)$$

$c_t^c$  is the representation of each code,  $\cdot$  is the element-wise product operation.

**Copy module for complication detection** A code vocabulary  $\mathcal{V}_j = \{v_1, \dots, v_N\}$  is designed for code  $c$  as its potential complication disease and use UNK for any code have low probability to be complication. As  $\mathcal{C}$  is the whole code dictionary, considering code of  $\mathcal{C}$  let this module consider non-complication diseases. Then Given the decoder lstm state  $h_{t-1}$  at time  $t-1$ , we generate the 'mixture' probability of code  $c_t$  as follows:

$$\begin{aligned} p(c_t | \mathbf{h}_t, c_{t-1}) \\ = p(c_t, c | \mathbf{h}_t, c_{t-1}, \mathcal{V}_{\setminus \text{UNK}}) + p(c_t, g | \mathbf{h}_t, c_{t-1}, \mathcal{C}) \end{aligned} \quad (5)$$

where  $g$  represents the generate-mode, and  $c$  denotes the copy mode. The probabilities for these two modes are given respectively by:

$$p(c_t, c | \cdot) = \begin{cases} \frac{1}{Z} e^{\psi_c(h_t)}, & y_t \in \mathcal{V} \\ 0, & y_t \in \mathcal{X} \cap \bar{\mathcal{V}} \end{cases} \quad (6)$$

$$p(c_t, g | \cdot) = \frac{1}{Z} \sum_{j: c_j = y_t} e^{\psi_g(h_j)} \quad (7)$$

$\psi_g(\cdot)$  and  $\psi_c(\cdot)$  are rating methods, and we treat  $Z$  as the normalization term  $Z = \sum_{v \in \mathcal{V} \cup \text{UNK}} e^{\psi_g(v)} + \sum_{x \in \mathcal{X}} e^{\psi_c(x)}$ . Caused by this normalization term, above two modes essentially compete through a softmax function. The score of each mode is calculated:

*Generate-Mode:* The rating function used is same as in the generic RNN encoder-decoder [2],

$$\psi_g(y_t = v_i) = \mathbf{v}_i^\top \mathbf{W}_o \mathbf{h}_t, \quad c_i \in \mathcal{C} \quad (8)$$

where  $\mathbf{W}_o \in \mathbb{R}^{(N+1) \times d_s}$  is a weight matrix and  $v_i$  is one-hot representation of  $c_i$ .

*Copy-Mode:* The rating for copy module is calculated as

$$\psi_c(c_t = x_j) = \sigma(\mathbf{h}_j^\top \mathbf{W}_c) \mathbf{h}_t, \quad x_j \in \mathcal{V} \quad (9)$$

In this equation,  $\mathbf{W}_c \in \mathbb{R}^{d_h \times d_s}$  is the weight matrix, and  $\sigma$  is activation function. Empirically, we discovered that non-linearity activation tanh performs better than other activation function, and we utilize the one-hot complicating disease vector for  $h_t$ .

### 3.4 EHR encoder

In this section, we extract the representation  $x$  of each EHR for the sake of later processing by multi-channel CNN[5]. The first step in this encoder is embedding the tokens in the EHR into a embedding matrix  $X \in I^{n \times d}$   $n$  is the total number of tokens among all EHR and  $d$  is the dimension of the embedding matrix. In the convolutional layers, we apply  $c_i$  different filters to each kernel size  $k_i, 1 \leq i \leq m$ . Each filter  $f_{ij}, 1 \leq j \leq c_i$ , is a matrix  $\in \mathbb{R}^{k_i \times d}$ , and it is used for  $k_i$  words in text to produce a feature map  $\mathbf{F}_{ij} \in \mathbb{R}^{(n-k_i+1) \times 1}$ :

$$\mathbf{F}_{ij}[p] = \text{ReLU}(\mathbf{f}_{ij} \cdot \mathbf{X}_{p:p+k_i-1} + b_{ij}), \quad (10)$$

where  $\cdot$  denotes the dot product,  $\mathbf{X}_{p:p+k_i-1}$  is the  $p$ -th to  $(p+k_i-1)$ -th row of  $\mathbf{X}$ ,  $b_{ij}$  is a bias term, and ReLU is nonlinear activation function.

Next, we utilize max-pooling to each feature map  $\mathbf{F}_{ij}$  to obtain a scalar  $s_{ij}$ :

$$s_{ij} = \max_p \mathbf{F}_{ij}[p]. \quad (11)$$

Finally, we concatenate all the  $s_{ij}$  as the final representation of the text:

$$\mathbf{x} = [s_{11}, s_{12}, \dots, s_{m c_m}]. \quad (12)$$

**Orderless Recurrent Models** As code for each EHR is orderless, we need to find a way to compare our generated code which is in order, we adopt the concept from [28] to align them with the network’s predictions before calculating the loss. We use the predicted label alignment (PLA) to achieve this goal.

The core idea behind PLA is when predicted label is true, we prefer to keep it. Which leads to the following optimization problem:

$$\begin{aligned} \mathcal{L} = & \min_T \text{tr}(T \log(P)) \\ \text{subject to} & \quad T_{tj} \in \{0, 1\}, \sum_j T_{tj} = 1 \\ & \quad T_{tj} = 1 \text{ if } \hat{l}_t \in L \text{ and } j = \hat{c}_t \\ & \quad \sum_t T_{tj} = 1 \quad \forall j \in L \\ & \quad \sum_t T_{tj} = 0 \quad \forall j \notin L \end{aligned} \quad (13)$$

$\hat{c}_t$  represents the model’s predicted label at time step  $t$ . Initially, we secure the elements in matrix  $T$  corresponding to predictions that are verified by the ground truth set  $L$ . Subsequently, we employ the Hungarian algorithm to allocate remaining labels. This approach offers greater alignment with the labels that the LSTM model actually predicts.

### 3.5 Path Discriminator $D_\phi$

For the sake of training the path generator in a more efficient way, we refer from the idea of GAN to design a path discriminator module  $D_\phi$ ,  $D_\phi$  is designed to

generate a reward  $r_t$  for every pairs of EHR representation  $x$  and path representation generated by a path encoder, ICD code path  $y_t = (c_1, c_2, \dots, c_k, \dots, c_t)$  by path generator we generate the path representation by lstm encoder:

$$h_k = LSTM(h_{k-1}, c_k), \quad (14)$$

$h_{k-1}$  is the hidden state at timestamp  $k-1$ ;  $c_k$  is the  $k$ -th ICD code representation. Then the calculation of  $r_t$  is shown below:

$$\begin{aligned} r_t &= R_{(s_t, x), a_t} \\ &= p_D(y_t, \mathbf{x}) \\ &= \sigma(\mathbf{W}_r(\mathbf{h}_t \oplus \mathbf{x})), \end{aligned} \quad (15)$$

$\oplus$  represents concatenation,  $\mathbf{W}_r$  represents weight of a linear layer. The path  $y_t$  is obtained by recurrently applying an LSTM to the ICD code path  $y_t = (c_1, c_2, \dots, c_k, \dots, c_t)$ , and  $\sigma$  represents the sigmoid function.

We train the path discriminator using adversarial training strategy. Here, the paths generated by the path generator are treated as negative samples, the ground truth paths are considered as positive samples. We optimize a cross-entropy function to improve the effectiveness of  $D_\phi$ :

$$\begin{aligned} L_D &= -\sum_{(y_t, x) \in Q^+} \log p_D(y_t, x) \\ &\quad - \sum_{(y_t, x) \in Q^-} \log(1 - p_D(y_t, x)), \end{aligned} \quad (16)$$

$Q^+$  and  $Q^-$  represent a pair of positive and negative samples, respectively;  $p_D(y_t, x)$  is the probability of sample  $(y_t, x)$  belonging to a positive sample.

## 4 Experimental Design

### 4.1 Research Questions

We plan to solve the following research problems:(RQ1)How well CRNNet preform on find the complicating disease. (RQ2) What are the effects of different components? Where do the improvements of CRNNet come from?

### 4.2 Dataset

We use MIMIC-III as the dataset for comparison, which is a large EHR dataset. To further elaborate, we preprocess the EHRs by first removing any personally identifiable information, such as patient and hospital names, as well as other irrelevant information like medications and procedures not related to the patient’s diagnosis. We also tokenize the remaining text and use stopword removal and stemming to preprocess the EHR. To simplify the problem, we use a top-50 label setting to preprocess the dataset.

For the top-50 label setting, we only use the most frequent 50 codes from the dataset and filter out instances that do not contain at least one of these codes.



This results in a subset of the dataset that is more focused and relevant to our task.

The split ratio of the train, test, and validation datasets from the resulting dataset is 4:1:1, with each set containing approximately 80%, 10%, and 10% of the instances, respectively. This allows us to evaluate the performance of our models on unseen data while ensuring the training set is large enough for effective learning.

### 4.3 Baselines

To demonstrate the performance and functionality of CRNNet, several methods are re-implemented for comparison. Specifically, we compare CRNNet with following methods:

*CAML*[20] CAML leverages Text-CNN[5] to generate representations for each Electronic Health Record (EHR). It then employs attention module to learn salient features for coding. This tailored representation forms the basis for binary classification tasks.

*RPGNet*[7] RPGNet approaches EHR coding by employing a dual structure consisting of a Path Generator (PG) and a Path Discriminator (PD). They propose PMP module to encode the path. In addition, the PD component calculates a reward value for every generated path. The network is trained using adversarial learning strategy.

*PLM-ICD*[12] PLM-ICD utilizes Pretrained Language Models to obtain context-rich representations. It use transformer methods the encode the EHR content. It currently stands as the state-of-the-art method for ICD classification.

### 4.4 Metric

In our study, we utilize a comprehensive set of evaluation metrics, frequently employed in related work [20]. Our evaluation framework incorporates both micro- and macro-averaged metrics. The micro-averaged approach treats each instance as a separate prediction during computation, whereas the macro-averaged method averages metrics for each individual label, making it especially relevant for assessing performance on rare labels. More specifically, we examine four primary metrics: Precision, Recall, F1 Score, and the Area Under the Curve (AUC) [9]. The F1 Score is the harmonic mean of Precision and Recall, and the AUC provides a summary of the model’s performance across various thresholds. Additionally, we employ the Jaccard Similarity Coefficient as an overlap measure between the sets of predicted and actual ICD codes [21]. This coefficient is defined as

$$Jaccard = \frac{1}{m} \sum_{i=1}^m \frac{|Y_i \cap \hat{Y}_i|}{|Y_i \cup \hat{Y}_i|},$$

$m$  denotes the number of code in the dataset, while  $Y_i$  is the set of predicted codes, and  $\hat{Y}_i$  represents the set of actual codes. Furthermore, we gauge the models' effectiveness in identifying complications by evaluating the proportion of complications in each disease combination present in the predictions. The formula for computing the complication ratio is as follows:

$$complication = \frac{\sum_{1 \leq i < j \leq n} I(c_i, c_j)}{\binom{2}{n}} \quad (17)$$

where  $I(c_i, c_j)$  represent whether code  $i$  and code  $j$  is a pair of complication,  $n$  represent the number of codes in the prediction.

#### 4.5 Implementation details

We use 300 as the dimension for the representation of EHR and path, and the dimension of the token and code embedding is set as 100(Eq. 3 and Eq. 4). For the EHR encoder, the filter size of convolutional layers is 100, while the kernal size of these layers are 3, 4, 5, respectively. while the the drop ratio of the dropout is 0.5 (Eq. 11). For EHR-ICD fusion module, we set the hidden size of LSTM gate as 300. In training stage, we use 200 as the max train iteration, and the batch size is set as 32. We train path generator and path discriminator in every batch alternately. All model parameters are randomly initialized. Adam optimizer[15] is employed to train the objective function, learning rate chosen as 0.0001 and default momentum parameters of  $\beta_1 = 0.9$  and  $\beta_2 = 0.999$ . The code is implemented in PyTorch and we train it on an NVIDIA T4 Tensor Core GPU.

**Table 1.** Results(%) on dataset, bold face indicates the best result.

Method	Jaccard	Complication	Precision		Recall		F1		AUC	
			Micro	Macro	Micro	Macro	Micro	Macro	Micro	Macro
CAML(CNN)	27.68	24.57	58.59	38.35	40.25	33.50	47.63	33.59	68.31	66.35
RPGNet(CNN)	33.34	36.31	41.20	33.59	56.81	44.51	48.35	35.40	75.14	70.50
CRNNNet(CNN)	<u>33.79</u>	<b>57.30</b>	54.67	34.74	43.59	32.01	<u>48.45</u>	31.31	69.58	65.36
PLM-ICD(Bert)	<b>54.87</b>	42.29	<b>68.26</b>	<b>64.24</b>	<b>71.25</b>	<b>66.74</b>	<b>69.72</b>	<b>65.46</b>	<b>92.64</b>	<b>90.14</b>

**Table 2.** Ablation study

Method	Jaccard	Complication	Precision		Recall		F1		AUC	
			Micro	Macro	Micro	Macro	Micro	Macro	Micro	Macro
CRNNNet	33.79	<b>57.30</b>	54.67	34.74	43.59	32.01	48.45	31.31	69.58	65.36
CRNNNet(no-copy)	35.05	51.86	54.64	35.03	45.39	31.93	49.52	31.28	70.39	65.15
CRNNNet(no-ARL)	34.09	55.80	54.57	34.10	44.73	31.79	49.08	30.94	70.08	65.10

## 5 Experimental Result

### 5.1 RQ1.1

We assessed the performance of various models, including Caml, RPGnet, CRNNet, and PLM-ICD. We evaluated these models using the top-50 label setting and trained the first three models with the same preprocessing method. Additionally, we incorporated a pretrained PLM-ICD (BERT) model in our analysis. The results presented in Table 1 lead to the following observations:

Among the compared models, CRNNet achieved the highest complication ratio. Notably, CRNNet’s complication ratio was 15.01% higher than PLM-ICD, the state-of-the-art method for EHR coding. This indicates that CRNNet effectively identifies complications associated with other codes. This may be attributed to CRNNet’s exploration of ICDs through a sequence of paths, as well as its utilization of information from previous codes to generate new ones.

### 5.2 Ablation study(RQ1.2)

We conducted an ablation study to evaluate the effects of modules in CRNNet, shown in Table 2. Followings are ablation of CRNNet that we considered: (1) No copy represents CRNNet removed the copy module. We removed the copy module and used only the RNN structure model to generate codes. (2) No ARL represents CRNNet removed adversarial learning strategy. We removed the adversarial learning process to train our model. From the results, we obtained the following finding:

First, the ability of CRNNet to identify complication diseases decreased dramatically after removing the copy module. Specifically, the complication ratio in the result of CRNNet(no-copy) dropped by 5.44% respectively. The result shows that copy module plays a significant role in our method to identify complicating diseases. The copy module extracts information related to complicating diseases based on the former ICD in the path, which helps to generate complicating diseases.

Second, the ability of CRNNet to identify complicating diseases is still working better than PLM-ICD when copy module is not used. The complication ratio of PLM-ICD is 42.29% and that of CRNNet(no-copy) is 51.86%, which indicates that the RNN structure is also helpful in identifying complicating diseases, as the ICD on timestamp  $t + 1$  is generated based on the ICD on timestamp  $t$ .

Finally, the adversarial reinforcement learning (ARL) does not significantly improve the performance of CRNNet, but it slightly improves its ability to identify complicating diseases. This is due to adversarial reinforcement learning helps CRNNet generate codes paths similar to the ground truth paths.

## 6 CONCLUSION AND FUTURE WORK

In this paper, we propose an innovative approach for Electronic Health Record (EHR) coding, specifically targeting the identification of complicating diseases.

We frame this as a path generation task and introduce the Copy Recurrent Neural Network Structure Network (CRNNet). CRNNet consists of a EHR-ICD fusion module designed to fuse the representation of EHRs and code path. An adversarial learning framework is used for training stage. Our experimental results on the MIMIC-III dataset reveal that CRNNet surpasses existing methods in detecting complicating diseases, and its performance excels when using the CNN encoder method. The performance improvement is attributed to the implementation of the copy module and the adversarial reinforcement learning mechanisms.

Nonetheless, CRNNet’s limitations lie in its improvement of recall and AUC. While it performs well in detecting complications, it does not focus on enhancing basic performance metrics. Additionally, although it is based on a CNN encoder, transformer methods are now considered a more efficient way to encode EHRs. In future research, we will focus on integrating transformer methods and improving performance with the aid of complication detection, which is a crucial task in the EHR coding area.

## 7 DATA AVAILABILITY

We make our code and dataset publicly available at:

<https://anonymous.4open.science/r/CRNNNet-D780>

## References

1. A. Avati, K. Jung, S. Harman, L. Downing, A. Ng, and N. H. Shah. Improving palliative care with deep learning. *BMC medical informatics and decision making*, 18(4):55–64, 2018.
2. D. Bahdanau, K. Cho, and Y. Bengio. Neural machine translation by jointly learning to align and translate. *arXiv preprint arXiv:1409.0473*, 2014.
3. T. Baumel, J. Nassour-Kassis, R. Cohen, M. Elhadad, and N. Elhadad. Multi-label classification of patient notes a case study on icd code assignment. *arXiv preprint arXiv:1709.09587*, 2017.
4. P. Cao, Y. Chen, K. Liu, J. Zhao, S. Liu, and W. Chong. Hypercore: Hyperbolic and co-graph representation for automatic icd coding. In *Proceedings of the 58th Annual Meeting of the Association for Computational Linguistics*, pages 3105–3114, 2020.
5. Y. Chen. Convolutional neural network for sentence classification. Master’s thesis, University of Waterloo, 2015.
6. E. Choi, M. T. Bahadori, A. Schuetz, W. F. Stewart, and J. Sun. Doctor ai: Predicting clinical events via recurrent neural networks. In *Machine learning for healthcare conference*, pages 301–318. PMLR, 2016.
7. E. Choi, S. Biswal, B. Malin, J. Duke, W. F. Stewart, and J. Sun. Generating multi-label discrete patient records using generative adversarial networks. In *Machine learning for healthcare conference*, pages 286–305. PMLR, 2017.
8. C. Esteban, S. L. Hyland, and G. Rätsch. Real-valued (medical) time series generation with recurrent conditional gans. *arXiv preprint arXiv:1706.02633*, 2017.

9. C. Goutte and E. Gaussier. A probabilistic interpretation of precision, recall and f-score, with implication for evaluation. In *Advances in Information Retrieval: 27th European Conference on IR Research, ECIR 2005, Santiago de Compostela, Spain, March 21-23, 2005. Proceedings 27*, pages 345–359. Springer, 2005.
10. A. Graves and A. Graves. Long short-term memory. *Supervised sequence labelling with recurrent neural networks*, pages 37–45, 2012.
11. J. Guan, R. Li, S. Yu, and X. Zhang. Generation of synthetic electronic medical record text. In *2018 IEEE International Conference on Bioinformatics and Biomedicine (BIBM)*, pages 374–380. IEEE, 2018.
12. C.-W. Huang, S.-C. Tsai, and Y.-N. Chen. Plm-icd: automatic icd coding with pretrained language models. *arXiv preprint arXiv:2207.05289*, 2022.
13. R. Kavuluru, A. Rios, and Y. Lu. An empirical evaluation of supervised learning approaches in assigning diagnosis codes to electronic medical records. *Artificial intelligence in medicine*, 65(2):155–166, 2015.
14. B.-H. Kim and V. Ganapathi. Read, attend, and code: pushing the limits of medical codes prediction from clinical notes by machines. In *Machine Learning for Healthcare Conference*, pages 196–208. PMLR, 2021.
15. D. P. Kingma and J. Ba. Adam: A method for stochastic optimization, 2017.
16. F. Li and H. Yu. Icd coding from clinical text using multi-filter residual convolutional neural network. In *proceedings of the AAAI conference on artificial intelligence*, volume 34, pages 8180–8187, 2020.
17. Y. Liu, H. Cheng, R. Klopfer, M. R. Gormley, and T. Schaaf. Effective convolutional attention network for multi-label clinical document classification. In *Proceedings of the 2021 Conference on Empirical Methods in Natural Language Processing*, pages 5941–5953, 2021.
18. L. R. Medsker and L. Jain. Recurrent neural networks. *Design and Applications*, 5(64-67):2, 2001.
19. R. Miotto, F. Wang, S. Wang, X. Jiang, and J. T. Dudley. Deep learning for healthcare: review, opportunities and challenges. *Briefings in bioinformatics*, 19(6):1236–1246, 2018.
20. J. Mullenbach, S. Wiegrefe, J. Duke, J. Sun, and J. Eisenstein. Explainable prediction of medical codes from clinical text. *arXiv preprint arXiv:1802.05695*, 2018.
21. S. Niwattanakul, J. Singthongchai, E. Naenudorn, and S. Wanapu. Using of jaccard coefficient for keywords similarity. In *Proceedings of the international multiconference of engineers and computer scientists*, volume 1, pages 380–384, 2013.
22. H. Shi, P. Xie, Z. Hu, M. Zhang, and E. P. Xing. Towards automated icd coding using deep learning. *arXiv preprint arXiv:1711.04075*, 2017.
23. H. Taud and J. Mas. Multilayer perceptron (mlp). *Geomatic approaches for modeling land change scenarios*, pages 451–455, 2018.
24. S.-C. Tsai, T.-Y. Chang, and Y.-N. Chen. Leveraging hierarchical category knowledge for data-imbalanced multi-label diagnostic text understanding. In *Proceedings of the Tenth International Workshop on Health Text Mining and Information Analysis (LOUHI 2019)*, pages 39–43, 2019.
25. T. Vu, D. Q. Nguyen, and A. Nguyen. A label attention model for icd coding from clinical text. *arXiv preprint arXiv:2007.06351*, 2020.
26. S. Wang, P. Ren, Z. Chen, Z. Ren, J.-Y. Nie, J. Ma, and M. de Rijke. Coding electronic health records with adversarial reinforcement path generation. In *Proceedings of the 43rd International ACM SIGIR conference on research and development in Information Retrieval*, pages 801–810, 2020.

27. X. Xie, Y. Xiong, P. S. Yu, and Y. Zhu. Ehr coding with multi-scale feature attention and structured knowledge graph propagation. In *Proceedings of the 28th ACM international conference on information and knowledge management*, pages 649–658, 2019.
28. V. O. Yazici, A. Gonzalez-Garcia, A. Ramisa, B. Twardowski, and J. v. d. Weijer. Orderless recurrent models for multi-label classification. In *Proceedings of the IEEE/CVF Conference on Computer Vision and Pattern Recognition*, pages 13440–13449, 2020.
29. K. Yu, Y. Wang, Y. Cai, C. Xiao, E. Zhao, L. Glass, and J. Sun. Rare disease detection by sequence modeling with generative adversarial networks. *arXiv preprint arXiv:1907.01022*, 2019.
30. L. Yu, W. Zhang, J. Wang, and Y. Yu. Seqgan: Sequence generative adversarial nets with policy gradient. In *Proceedings of the AAAI conference on artificial intelligence*, volume 31, 2017.
31. T. Zhou, P. Cao, Y. Chen, K. Liu, J. Zhao, K. Niu, W. Chong, and S. Liu. Automatic icd coding via interactive shared representation networks with self-distillation mechanism. In *Proceedings of the 59th Annual Meeting of the Association for Computational Linguistics and the 11th International Joint Conference on Natural Language Processing (Volume 1: Long Papers)*, pages 5948–5957, 2021.