

---

# CHECKPOINT-BASED ROLLBACK RECOVERY IN SESSION-BASED PROGRAMMING

CLAUDIO ANTARES MEZZINA <sup>a</sup>, FRANCESCO TIEZZI <sup>b</sup>, AND NOBUKO YOSHIDA <sup>c</sup>

<sup>a</sup> Dipartimento di Scienze Pure e Applicate, Università di Urbino, Italy

<sup>b</sup> Università degli Studi di Firenze, Italy

<sup>c</sup> University of Oxford, United Kingdom

---

**ABSTRACT.** To react to unforeseen circumstances or amend abnormal situations in communication-centric systems, programmers are in charge of “undoing” the interactions which led to an undesired state. To assist this task, session-based languages can be endowed with reversibility mechanisms. In this paper we propose a language enriched with programming facilities to *commit* session interactions, to *roll back* the computation to a previous commit point, and to *abort* the session. Rollbacks in our language always bring the system to previous visited states and a rollback cannot bring the system back to a point prior to the last commit. Programmers are relieved from the burden of ensuring that a rollback never restores a checkpoint imposed by a session participant different from the rollback requester. Such undesired situations are prevented at design-time (statically) by relying on a decidable *compliance* check at the type level, implemented in MAUDE. We show that the language satisfies error-freedom and progress of a session.

## 1. INTRODUCTION

Reversible computing [ACG<sup>+</sup>20, MSG<sup>+</sup>20] has gained interest for its application to different fields: from modelling biological/chemical phenomena [KU18], to simulation [PP13], debugging [Eng12, GLM14, LSU22] and modelling fault-tolerant systems [DK05, LLM<sup>+</sup>13, VS18]. Our interest focuses on this latter application and stems from the fact that reversibility can be used to rigorously model, implement and revisit programming abstractions for reliable software systems.

Recent works [BLd17, MP17, MP21, CDG17, TY15] have studied the effect of reversibility in communication-centric scenarios, as a way to correct faulty computations by bringing back the system to a previous consistent state. In this setting, processes’ behaviours are strongly disciplined by their types, prescribing the actions they have to perform within a *session*. A session consists of a structured series of message exchanges, whose flow can be controlled via conditional choices, branching and recursion. Correctness of communication is statically guaranteed by a framework

---

This research was funded in whole, or in part, by EPSRC EP/T006544/2, EP/K011715/1, EP/K034413/1, EP/L00058X/1, EP/N027833/2, EP/N028201/1, EP/T014709/2, EP/V000462/1, EP/X015955/1, NCSS/EP SRC VeTSS and Horizon EU TaRDIS 101093006. by MIUR PRIN project NiRvAna, by French ANR project DCore ANR-18-CE25-0007, by INdAM – GNCS 2022 project *Proprietà qualitative e quantitative di sistemi reversibili*, and the project SERICS (PE00000014) under the NRRP MUR program funded by the EU - NextGenerationEU.

based on a (session) type discipline [HLV<sup>+</sup>16]. None of the aforementioned works addresses systems in which the participants can *explicitly* abort the session, commit a computation and roll it back to a previous checkpoint. In this paper, we aim at filling this gap. We explain below the distinctive aspects of our checkpoint-based rollback recovery approach.

**Linguistic primitives to explicitly program reversible sessions.** We introduce three primitives to: (i) *commit* a session, preventing undoing the interactions performed so far along the session; (ii) *roll back* a session, restoring the last saved process checkpoints; (iii) *abort* a session, to discard the session, and hence all interactions already performed in it, thus allowing another session of the same protocol to start with possible different participants. Notice that most proposals in the literature (e.g., [BDd14, BDLd16, BLd17]) only consider an abstract view, as they focus on reversible contracts (i.e., types). Instead, we focus on programming primitives at process level, and use types for guaranteeing a safe and consistent system evolution.

**Asynchronous commits.** Our commit primitive does not require a session-wide synchronisation among all participants, as it is a local decision. However, its effect is on the whole session, as it affects the other session participants. This means that each participant can independently decide when to commit. Such flexibility comes at the cost of being error-prone, especially considering that the programmer has not only to deal with the usual forward executions, but also with the backward ones. Our type discipline allows for ruling out programs which may lead to these errors. The key idea of our approach is that *a session participant executing a rollback action is interested in restoring the last checkpoint he/she has committed*. For the success of the rollback recovery it is irrelevant whether the ‘passive’ participants go back to their own last checkpoints. Instead, if the ‘active’ participant is unable to restore the last checkpoint he/she has created, because it has been replaced by a checkpoint imposed by another participant, the rollback recovery is considered unsatisfactory.

In our framework, programmers are relieved from the burden of ensuring the satisfaction of rollbacks, since undesired situations are prevented at design time (statically) by relying on a *compliance* check at the type level. To this end, we introduce *cherry- $\pi$*  (checkpoint-based rollback recovery  $\pi$ -calculus), a variant of the session-based  $\pi$ -calculus [YV07] enriched with rollback recovery primitives. A key difference with respect to the standard binary type discipline is the *relaxation* of the duality requirement. The types of two session participants are not required to be dual, but they will be compared with respect to a compliance relation (as in [BLd18]), which also takes into account the effects of commit and rollback actions. Such relaxation also involves the requirements concerning selection and branching types, and those concerning branches of conditional choices. The *cherry- $\pi$*  type system is used to infer types of session participants, which are then combined together for the compliance check.

Reversibility in *cherry- $\pi$*  is *controlled* via two specific primitives: a rollback one telling when a reverse computation has to take place, and a commit one limiting the scope of a potential reverse computation. This implies that the calculus is not fully reversible (i.e., backward computations are not always enabled), leading to have properties that are relaxed and different with respect to other reversible calculi [DK04, CKV13, LMS10, TY15]. We prove that *cherry- $\pi$*  satisfies the following properties: (i) a rollback always brings back the system to a previous visited state and (ii) it is not possible to bring the computation back to a point prior to the last checkpoint, which implies that our commits have a persistent effect. Concerning soundness properties, we prove that (a) our compliance check is decidable, (b) compliance-checked *cherry- $\pi$*  specifications never lead to communication errors (e.g., a blocked communication where there is a receiver without the corresponding sender), and (c) compliance-checked *cherry- $\pi$*  specifications never activate undesirable rollbacks (according to

our notion of rollback recovery mentioned above). Property (b) resembles the type safety property of session-based calculi (see, e.g., [YV07]), while property (c) is a new property specifically defined for `cherry-pi`. The technical development of property proofs turns out to be more intricate than that of standard properties of session-based calculi, due to the combined use of type and compliance checking. To demonstrate feasibility and effectiveness of our rollback recovery approach, we have concretely implemented the compliance check using the MAUDE [CDE<sup>+</sup>07] framework (the code is available at <https://github.com/tiezzi/cherry-pi>).

**Outline.** Sec. 2 illustrates the key idea of our rollback recovery approach. Sec. 3 introduces the `cherry-pi` calculus. Sec. 4 introduces typing and compliance checking. Sec. 5 illustrates the MAUDE implementation of the compliance checking. Sec. 6 presents the properties satisfied by `cherry-pi`. Sec. 7 show the application of the `cherry-pi` approach to a speculative execution scenario. Sec. 8 discusses related work. Finally, Sec. 9 concludes the paper with future work. The appendix reports on the omitted proofs.

This paper is a revised and enhanced version of [MTY23]. In particular:

- Sec. 3 has been extended with rules in Fig. 4 and 5, which are omitted in [MTY23], to provide a complete account of the `cherry-pi` semantics.
- Sec. 4 has been extended with omitted rules (Fig. 7 and 10 are new, while Fig. 9 and 11 have been extended), to provide a full account of the `cherry-pi` typing discipline. Moreover, the section includes the proof of Theorem 4.2.
- Sec. 6 has been extended by including full proofs of the results regarding the properties of `cherry-pi`.
- Sec. 7 is new. It shows the `cherry-pi` approach at work on a new scenario to provide a better understanding of the practical application of `cherry-pi` and, in particular, of the MAUDE implementation of its type semantics.
- Sec. 8 has been revised and expanded, including the discussion of more recent related work and a table (Tab. 1) providing a comparison of the related approaches in the literature.
- Finally, more commentary and explanations have been added throughout the paper, and the whole presentation has been carefully refined.

## 2. A REVERSIBLE VIDEO ON DEMAND SERVICE EXAMPLE

We discuss the motivations underlying our work by introducing our running example, a Video on Demand (VOD) scenario. The key idea is that a rollback requester is satisfied only if her restored checkpoint was set by herself. In Fig. 1(a), a service ( $S$ ) offers to a user ( $U$ ) videos with two different quality levels, namely high definition (HD) and standard definition (SD). After the *login*,  $U$  sends her video *request*, and receives the corresponding *price* and *metadata* (actors, directors, description, etc.) from  $S$ . According to this information,  $U$  selects the video quality. Then, she receives, first, a short *test* video (to check the audio and video quality in her device) and, finally, the requested *video*. If the vision of the HD test video is not satisfactory,  $U$  can roll back to her last checkpoint to possibly change the video quality, instead in the SD case  $U$  can abort the session.

Let us now add commit actions as in the run shown in Fig. 1(b). After receiving the price,  $U$  commits, while  $S$  commits after the quality selection. In this scenario, however, if  $U$  activates the rollback, she is unable to go back to the checkpoint she set with her commit action because the actual effect of rollback is to restore the checkpoint set by the commit action performed by  $S$ . Hence,  $U$  cannot use the rollback mechanism to undo her video quality choice and select the SD video.

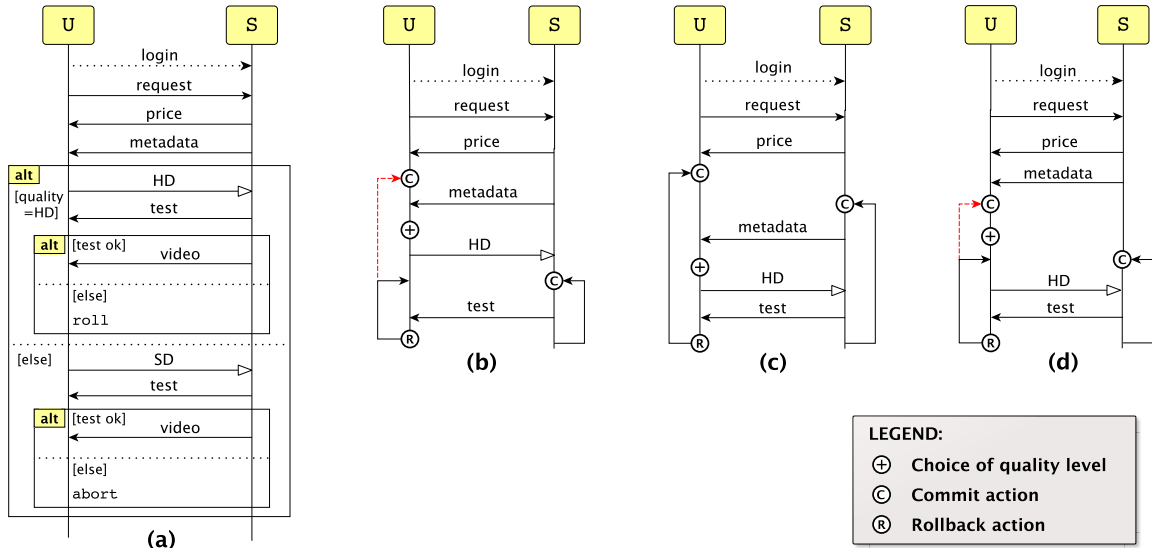

Figure 1: VOD example: (a) a full description without commit actions; (b,d) runs with undesired rollback; (c) a run with satisfactory rollback.

In the scenario in Fig. 1(c), instead,  $S$  commits after sending the price to  $U$ . In this case, no matter who first performed the commit action, the rollback results to be satisfactory. Also if  $S$  commits later, the checkpoint of  $U$  remains unchanged, as  $U$  performed no other action between the two commits. This would not be the case if both  $U$  and  $S$  committed after the communication of the metadata, as in Fig. 1(d). If  $S$  commits before  $U$ , no rollback issue arises, but if  $U$  commits first it may happen that her internal decision is taken before  $S$  commits. In this case,  $U$  would not be able to go back to the checkpoint set by herself, and she would be unable to change the video quality.

These undesired rollbacks are caused by bad choices of commit points. We propose a compliance check that identifies these situations at design time.

### 3. THE cherry- $\pi$ CALCULUS

In this section, we introduce *cherry- $\pi$* , a calculus (extending that in [YV07]) devised for studying sessions equipped with our checkpoint-based rollback recovery mechanism.

**3.1. Syntax.** The syntax of the *cherry- $\pi$*  calculus relies on the following base sets: *shared channels* (ranged over by  $a$ ), used to initiate sessions; *session channels* (ranged over by  $s$ ), consisting of pairs of *endpoints* (ranged over, with a slight abuse of notation, by  $s, \bar{s}$ ) used by the two parties to interact within an established session; *labels* (ranged over by  $l$ ), used to select and offer branching choices; *values* (ranged over by  $v$ ), including booleans, integers and strings (whose *sorts*, ranged over by  $S$ , are `bool`, `int` and `str`, respectively), which are exchanged within a session; *variables* (ranged over by  $x, y, z$ ), storing values and session endpoints; *process variables* (ranged over by  $X$ ), used for recursion.

*Collaborations*, ranged over by  $C$ , are given by the grammar in Fig. 2. The key ingredient of the calculus is the set of actions for controlling the session rollback. Actions `commit`, `roll` and `abort` are used, respectively, to commit a session (producing a checkpoint for each session participant), to

$C ::=$ $\bar{a}(x).P \mid a(x).P \mid C_1 \mid C_2$	<b>Collaborations</b> request, accept, parallel
$P ::=$ $x!\langle e \rangle.P \mid x?(y : S).P$ $\mid x \triangleleft l.P \mid x \triangleright \{l_1 : P_1, \dots, l_n : P_n\}$ $\mid \text{if } e \text{ then } P_1 \text{ else } P_2 \mid X \mid \mu X.P \mid \mathbf{0}$ $\mid \text{commit}.P \mid \text{roll} \mid \text{abort}$	<b>Processes</b> output, input selection, branching choice, recursion, inact commit, roll, abort
$e ::= v \mid +(e_1, e_2) \mid \wedge(e_1, e_2) \mid \dots$	<b>Expressions</b>

---

Figure 2: cherry-pi syntax.

trigger the session rollback (restoring the last committed checkpoints) or to abort the whole session. We discuss below the other constructs of the calculus, which are those typically used for session-based programming [HVK98]. A *cherry-pi* collaboration is a collection of *session initiators*, i.e. terms ready to initiate sessions by synchronising on shared channels. A synchronisation of two initiators  $\bar{a}(x).P$  and  $a(y).Q$  causes the generation of a fresh session channel, whose endpoints replace variables  $x$  and  $y$  in order to be used by the triggered processes  $P$  and  $Q$ , respectively, for later communications. No subordinate sessions can be initiated within a running session.

When a session is started, each participant executes a *process*. Processes are built up from the empty process  $\mathbf{0}$  and basic actions by means of action prefix  $_.$ , conditional choice  $\text{if } e \text{ then } _ \text{ else } _$ , and recursion  $\mu X._$ . Actions  $x!\langle e \rangle$  and  $y?(z : S)$  denote output and input via session endpoints replacing  $x$  and  $y$ , respectively. These communication primitives realise the standard synchronous message passing, where messages result from the evaluation of *expressions*, which are defined by means of standard operators on boolean, integer and string values. Variables that are arguments of input actions are (statically) typed by sorts. There is no need for statically typing the variables occurring as arguments of session initiating actions, as they are always replaced by session endpoints. Notice that in *cherry-pi* the exchanged values cannot be endpoints, meaning that session delegation (i.e., channel-passing) is not considered. Actions  $x \triangleleft l$  and  $x \triangleright \{l_1 : P_1, \dots, l_n : P_n\}$  denote selection and branching respectively (where  $l_1, \dots, l_n$  are pairwise distinct).

**Example 3.1.** Let us consider the VOD example informally introduced in Sec. 2. The scenario described in Fig. 1(a) with commit actions placed as in Fig. 1(b) is rendered in *cherry-pi* as  $C_{\text{US}} = \overline{\text{login}}(x).P_{\text{U}} \mid \text{login}(y).P_{\text{S}}$ , where:

$$\begin{aligned}
 P_{\text{U}} &= x!\langle v_{\text{req}} \rangle. x?(x_{\text{price}} : \text{int}). \text{commit}. x?(x_{\text{meta}} : \text{str}). \text{if } (f_{\text{eval}}(x_{\text{price}}, x_{\text{meta}})) \\
 &\quad \text{then } x \triangleleft l_{\text{HD}}. x?(x_{\text{testHD}} : \text{str}). \\
 &\quad \quad (\text{if } (f_{\text{HD}}(x_{\text{testHD}})) \text{ then } x?(x_{\text{videoHD}} : \text{str}). \mathbf{0} \text{ else roll}) \\
 &\quad \text{else } x \triangleleft l_{\text{SD}}. x?(x_{\text{testSD}} : \text{str}). \\
 &\quad \quad (\text{if } (f_{\text{SD}}(x_{\text{testSD}})) \text{ then } x?(x_{\text{videoSD}} : \text{str}). \mathbf{0} \text{ else abort}) \\
 \\
 P_{\text{S}} &= y?(y_{\text{req}} : \text{str}). y!\langle f_{\text{price}}(y_{\text{req}}) \rangle. y!\langle f_{\text{meta}}(y_{\text{req}}) \rangle. \\
 &\quad y \triangleright \{ l_{\text{HD}} : \text{commit}. y!\langle f_{\text{testHD}}(y_{\text{req}}) \rangle. y!\langle f_{\text{videoHD}}(y_{\text{req}}) \rangle. \mathbf{0} , \\
 &\quad \quad l_{\text{SD}} : \text{commit}. y!\langle f_{\text{testSD}}(y_{\text{req}}) \rangle. y!\langle f_{\text{videoSD}}(y_{\text{req}}) \rangle. \mathbf{0} \}
 \end{aligned}$$

Notice that expressions used for decisions and computations are abstracted by relations  $f_n(\cdot)$ , whose definitions are left unspecified. Considering the placement of commit actions depicted in Fig. 1(c),

$$\begin{array}{l}
C ::= \bar{a}(x).P \mid a(x).P \mid C_1 \mid C_2 \mid (\nu s : C_1) C_2 \mid \langle P_1 \rangle \blacktriangleright P_2 \quad \text{Collaborations} \\
P ::= r!\langle e \rangle.P \mid r?(y : S).P \mid r \triangleleft l.P \mid r \triangleright \{l_1 : P_1, \dots, l_n : P_n\} \mid \dots \quad \text{Processes}
\end{array}$$

Figure 3: cherry-pi runtime syntax (the rest of processes  $P$  and expressions  $e$  are as in Fig. 2).

the cherry-pi specification of the service's process becomes:

$$\begin{aligned}
& y?(y_{req} : \mathbf{str}). y!\langle f_{price}(y_{req}) \rangle. \mathbf{commit}. y!\langle f_{meta}(y_{req}) \rangle. \\
& y \triangleright \{ l_{HD} : y!\langle f_{testHD}(y_{req}) \rangle. y!\langle f_{videoHD}(y_{req}) \rangle. \mathbf{0} , \\
& \quad l_{SD} : y!\langle f_{testSD}(y_{req}) \rangle. y!\langle f_{videoSD}(y_{req}) \rangle. \mathbf{0} \}
\end{aligned}$$

Finally, considering the placement of commit actions depicted in Fig. 1(d), the cherry-pi specification of the user's process becomes:

$$x!\langle v_{req} \rangle. x?(x_{price} : \mathbf{int}). x?(x_{meta} : \mathbf{str}). \mathbf{commit}. \mathbf{if} (f_{eval}(x_{price}, x_{meta})) \mathbf{then} \dots$$

**3.2. Semantics.** The operational semantics of cherry-pi is defined for *runtime* terms, generated by the extended syntax of the calculus in Fig. 3 (new constructs are highlighted by a grey background). We use  $r$  to denote *session identifiers*, i.e. session endpoints and variables. Those runtime terms that can be also generated by the grammar in Fig. 2 are called *initial collaborations*.

At collaboration level, two constructs are introduced:  $(\nu s : C_1) C_2$  represents a *session* along the channel  $s$  with associated starting checkpoint  $C_1$  (corresponding to the collaboration that has initialised the session) and code  $C_2$ ;  $\langle P_1 \rangle \blacktriangleright P_2$  represents a *log* storing the checkpoint  $P_1$  associated to the code  $P_2$ . At process level, the only difference is that session identifiers  $r$  are used as first argument of communicating actions. We extend the standard notion of binders to take into account  $(\nu s : C_1) C_2$ , which binds session endpoints  $s$  and  $\bar{s}$  in  $C_2$  (in this respect, it acts similarly to the restriction of  $\pi$ -calculus, but its scope cannot be extended in order to avoid involving processes that do not belong to the session in the rollback effect). The derived notions of bound and free names (where *names* stand for variables, process variables and session endpoints), alpha-equivalence (denoted by  $\equiv_\alpha$ ), and substitution are standard and we assume that bound names are pairwise distinct. The semantics of the calculus is defined for *closed* terms, i.e. terms without free variables and process variables.

Not all processes allowed by the extended syntax correspond to meaningful collaborations. In a general term the processes stored in logs may not be consistent with the computation that has taken place. We get rid of such malformed terms, as we will only consider those runtime terms, called *reachable* collaborations, obtained by means of reductions from initial collaborations.

The operational semantics of cherry-pi is given in terms of a standard *structural congruence*  $\equiv$  (given in Fig. 5) and a *reduction* relation  $\rightarrow$  given as the union of the *forward reduction* relation  $\rightarrow$  and *backward reduction* relation  $\rightsquigarrow$ . The definition of the relation  $\rightarrow$  over closed collaborations relies on an auxiliary labelled relation  $\xrightarrow{\ell}$  over processes that specifies the actions that processes can initially perform and the continuation process obtained after each such action. We consider all reduction relations closed under structural congruence. Given a reduction relation  $\mathcal{R}$ , we will indicate with  $\mathcal{R}^+$  and  $\mathcal{R}^*$  respectively the *transitive* and the *reflexive-transitive* closure of  $\mathcal{R}$ .

The operational rules defining the auxiliary labelled relation are in Fig. 4. We use  $k$  to denote *generic session endpoints* ( $s$  or  $\bar{s}$ ). Action label  $\ell$  stands for either  $k!\langle v \rangle$ ,  $k?(x)$ ,  $k \triangleleft l$ ,  $k \triangleright l$ , *cmt*, *roll*, *abt*, or  $\tau$ . The meaning of the rules is straightforward, as they just produce as labels the actions currently enabled in the process. In doing that, expressions of sending actions and conditional choices are evaluated (auxiliary function  $e \downarrow v$  says that closed expression  $e$  evaluates to value  $v$ ).

$$\begin{array}{l}
k!\langle e \rangle.P \xrightarrow{k!\langle v \rangle} P \quad (e \downarrow v) \quad [\text{P-SND}] \qquad k?(x : S).P \xrightarrow{k?(x)} P \quad [\text{P-RCV}] \\
k \triangleleft l.P \xrightarrow{k \triangleleft l} P \quad [\text{P-SEL}] \qquad k \triangleright \{l_1 : P_1, \dots, l_n : P_n\} \xrightarrow{k \triangleright l_i} P_i \quad (1 \leq i \leq n) \quad [\text{P-BRN}] \\
\text{if } e \text{ then } P_1 \text{ else } P_2 \xrightarrow{\tau} P_1 \quad (e \downarrow \text{true}) \quad [\text{P-IFT}] \\
\text{if } e \text{ then } P_1 \text{ else } P_2 \xrightarrow{\tau} P_2 \quad (e \downarrow \text{false}) \quad [\text{P-IFF}] \\
\text{commit}.P \xrightarrow{\text{cmt}} P \quad [\text{P-CMT}] \qquad \text{roll} \xrightarrow{\text{roll}} \mathbf{0} \quad [\text{P-RLL}] \qquad \text{abort} \xrightarrow{\text{abt}} \mathbf{0} \quad [\text{P-ABT}]
\end{array}$$

Figure 4: cherry-pi semantics: auxiliary labelled relation.

$$\begin{array}{l}
C_1 \mid C_2 \equiv C_2 \mid C_1 \qquad (C_1 \mid C_2) \mid C_3 \equiv C_1 \mid (C_2 \mid C_3) \\
P \equiv_{\alpha} Q \qquad \mu X.P \equiv P[\mu X.P/X]
\end{array}$$

Figure 5: Structural congruence for cherry-pi

The operational rules defining the reduction relation  $\mapsto$  are reported in Fig. 6. We comment on salient points. Once a session is created, its initiating collaboration is stored in the session construct (rule [F-CON]). Communication, branching selection and internal conditional choices proceed as usual, without affecting logs (rules [F-COM], [F-LAB] and [F-IF]). A commit action updates the checkpoint of a session, by replacing the processes stored in the logs of the two involved parties (rule [F-CMT]). Notably, this form of commit is asynchronous as it does not require the passive participant to explicitly synchronise with the active participant by means of a primitive for accepting the commit. On the other hand, under the hood, a low-level implementation of this mechanism would synchronously update the logs of the involved parties. Conversely, a rollback action restores the processes in the two logs (rule [B-RLL]). The abort action (rule [B-ABT]), instead, kills the session and restores the collaboration stored in the session construct formed by the two initiators that have started the session; this allows the initiators to be involved in new sessions. The other rules simply extend the standard parallel and restriction rules to forward and backward relations.

**Example 3.2.** Consider the first cherry-pi specification of the VOD scenario given in Ex. 3.1. In the initial state  $C_{US}$  of the collaboration, U and S can synchronise in order to initialise the session, thus evolving to  $C_{US}^1 = (\nu s : C_{US}) (\langle P_U[\bar{s}/x] \rangle \blacktriangleright P_U[\bar{s}/x] \mid \langle P_S[s/y] \rangle \blacktriangleright P_S[s/y])$ .

Let us consider now a possible run of the session. After three reduction steps, U executes the commit action, obtaining the following runtime term:

$$\begin{array}{l}
C_{US}^2 = (\nu s : C_{US}) (\langle P'_U \rangle \blacktriangleright P'_U \mid \langle P'_S \rangle \blacktriangleright P'_S) \\
P'_U = \bar{s}?(x_{\text{meta}} : \text{str}). \text{if } (f_{\text{eval}}(v_{\text{price}}, x_{\text{meta}})) \text{ then } \dots \quad P'_S = s!\langle f_{\text{meta}}(v_{\text{req}}) \rangle.y \triangleright \{ \dots \}
\end{array}$$

After four further reduction steps, U chooses the HD video quality and S commits as well; the resulting runtime collaboration is as follows:

$$\begin{array}{l}
C_{US}^3 = (\nu s : C_{US}) (\langle P''_U \rangle \blacktriangleright P''_U \mid \langle P''_S \rangle \blacktriangleright P''_S) \\
P''_U = \bar{s}?(x_{\text{testHD}} : \text{str}). \text{if } (f_{\text{HD}}(x_{\text{testHD}})) \text{ then } \bar{s}?(x_{\text{videoHD}} : \text{str}).\mathbf{0} \text{ else roll} \\
P''_S = s!\langle f_{\text{testHD}}(v_{\text{req}}) \rangle.s!\langle f_{\text{videoHD}}(v_{\text{req}}) \rangle.\mathbf{0}
\end{array}$$

$$\begin{array}{c}
\bar{a}(x_1).P_1 \mid a(x_2).P_2 \rightarrow (\nu s : (\bar{a}(x_1).P_1 \mid a(x_2).P_2)) \\
\quad (\langle P_1[\bar{s}/x_1] \rangle \blacktriangleright P_1[\bar{s}/x_1] \mid \langle P_2[s/x_2] \rangle \blacktriangleright P_2[s/x_2]) \quad \text{[F-CON]} \\
\\
\frac{P_1 \xrightarrow{\bar{k}!\langle v \rangle} P'_1 \quad P_2 \xrightarrow{k?(x)} P'_2}{\langle Q_1 \rangle \blacktriangleright P_1 \mid \langle Q_2 \rangle \blacktriangleright P_2 \rightarrow \langle Q_1 \rangle \blacktriangleright P'_1 \mid \langle Q_2 \rangle \blacktriangleright P'_2[v/x]} \quad \text{[F-COM]} \quad \frac{C_1 \rightarrow C'_1}{C_1 \mid C_2 \rightarrow C'_1 \mid C_2} \quad \text{[F-PAR]} \\
\\
\frac{P_1 \xrightarrow{\bar{k}\triangleleft l} P'_1 \quad P_2 \xrightarrow{k\triangleright l} P'_2}{\langle Q_1 \rangle \blacktriangleright P_1 \mid \langle Q_2 \rangle \blacktriangleright P_2 \rightarrow \langle Q_1 \rangle \blacktriangleright P'_1 \mid \langle Q_2 \rangle \blacktriangleright P'_2} \quad \text{[F-LAB]} \quad \frac{C_2 \rightarrow C'_2}{(\nu s : C_1) C_2 \rightarrow (\nu s : C_1) C'_2} \quad \text{[F-RES]} \\
\\
\frac{P_1 \xrightarrow{cmt} P'_1}{\langle Q_1 \rangle \blacktriangleright P_1 \mid \langle Q_2 \rangle \blacktriangleright P_2 \rightarrow \langle P'_1 \rangle \blacktriangleright P'_1 \mid \langle P_2 \rangle \blacktriangleright P_2} \quad \text{[F-CMT]} \quad \frac{P \xrightarrow{\tau} P'}{\langle Q \rangle \blacktriangleright P \rightarrow \langle Q \rangle \blacktriangleright P'} \quad \text{[F-IF]} \\
\\
\frac{P_1 \xrightarrow{roll} P'_1}{\langle Q_1 \rangle \blacktriangleright P_1 \mid \langle Q_2 \rangle \blacktriangleright P_2 \rightsquigarrow \langle Q_1 \rangle \blacktriangleright Q_1 \mid \langle Q_2 \rangle \blacktriangleright Q_2} \quad \text{[B-RLL]} \quad \frac{C_1 \rightsquigarrow C'_1}{C_1 \mid C_2 \rightsquigarrow C'_1 \mid C_2} \quad \text{[B-PAR]} \\
\\
\frac{P_1 \xrightarrow{abt} P'_1}{(\nu s : C)(\langle Q_1 \rangle \blacktriangleright P_1 \mid \langle Q_2 \rangle \blacktriangleright P_2) \rightsquigarrow C} \quad \text{[B-ABT]} \quad \frac{C_2 \rightsquigarrow C'_2}{(\nu s : C_1) C_2 \rightsquigarrow (\nu s : C_1) C'_2} \quad \text{[B-RES]}
\end{array}$$

Figure 6: cherry-pi semantics: forward and backward reduction relations.

$S ::= \text{bool} \mid \text{int} \mid \text{str}$	<b>Sorts</b>
$T ::= ![S].T \mid ?[S].T \mid \triangleleft[l].T \mid \triangleright[l_1 : T_1, \dots, l_n : T_n]$	<b>Session types</b>
$\mid T_1 \oplus T_2 \mid t \mid \mu t.T \mid \text{end} \mid \text{err} \mid \text{cmt}.T \mid \text{roll} \mid \text{abt}$	

Figure 7: cherry-pi type syntax.

In the next reductions,  $U$  evaluates the test video and decides to revert the session execution, resulting in  $C_{\text{US}}^4 = (\nu s : C_{\text{US}}) (\langle P''_U \rangle \blacktriangleright \text{roll} \mid \langle P''_S \rangle \blacktriangleright s!\langle f_{\text{videoHD}}(v_{\text{req}}) \rangle. \mathbf{0})$ . The execution of the roll action restores the checkpoints  $P''_U$  and  $P''_S$ , that is  $C_{\text{US}}^4 \rightsquigarrow C_{\text{US}}^3$ . After the rollback,  $U$  is not able to change the video quality as her own commit point would have permitted; in fact, it holds  $C_{\text{US}}^4 \not\rightsquigarrow C_{\text{US}}^2$ .

#### 4. ROLLBACK SAFETY

The operational semantics of cherry-pi provides a description of the functioning of the primitives for programming the checkpoint-based rollback recovery in a session-based language. However, as shown in Ex. 3.2, it does not guarantee high-level properties about the safe execution of the rollback. To prevent such undesired rollbacks, we propose the use of *compliance checking*, to be performed at design time. This check is not done on the full system specification, but only at the level of session types.

**4.1. Session types and typing.** The syntax of the cherry-pi *session types*  $T$  is defined in Fig. 7. Type  $![S].T$  represents the behaviour of first outputting a value of sort  $S$  (i.e., `bool`, `int` or `str`), then performing the actions prescribed by type  $T$ . Type  $?[S].T$  is the dual one, where a value is received instead of sent. Type  $\triangleleft[l].T$  represents the behaviour that selects the label  $l$  and then behaves as  $T$ . Type  $\triangleright[l_1 : T_1, \dots, l_n : T_n]$  describes a branching behaviour: it waits for one of the  $n$  options to be selected, and behaves as type  $T_i$  if the  $i$ -th label is selected (external choice). Type  $T_1 \oplus T_2$  behaves as either  $T_1$  or  $T_2$  (internal choice). Type  $\mu t.T$  represents a recursive behaviour



$$\frac{\emptyset; \emptyset \vdash P \triangleright x : T}{\bar{a}(x).P \triangleright \{\bar{a} : T\}} \text{[T-REQ]} \quad \frac{\emptyset; \emptyset \vdash P \triangleright x : T}{a(x).P \triangleright \{a : T\}} \text{[T-ACC]} \quad \frac{C_1 \triangleright A_1 \quad C_2 \triangleright A_2}{C_1 \mid C_2 \triangleright A_1 \cup A_2} \text{[T-PAR]}$$

Figure 8: Typing system for cherry-pi collaborations.

that starts by doing  $T$  and, when variable  $t$  is encountered, recurs to  $T$  again. Types `end` and `err` represent inaction and faulty termination, respectively. Type `cmt.T` represents a commit action followed by the actions prescribed by type  $T$ . Finally, types `roll` and `abt` represent rollback and abort actions.

The cherry-pi type system does not perform compliance checks, but only infers the types of collaboration participants, which will be then checked together according to the compliance relation. *Typing judgements* are of the form  $C \triangleright A$ , where  $A$ , called *type associations*, is a set of session type associations of the form  $\hat{a} : T$ , where  $\hat{a}$  stands for either  $\bar{a}$  or  $a$ . Intuitively,  $C \triangleright A$  indicates that from the collaboration  $C$  the type associations in  $A$  are inferred. The definition of the type system for these judgements relies on auxiliary typing judgements for processes, of the form  $\Theta; \Gamma \vdash P \triangleright \Delta$ , where  $\Theta$ ,  $\Gamma$  and  $\Delta$ , called *basis*, *sorting* and *typing* respectively, are finite partial maps from process variables to type variables, from variables to sorts, and from variables to types, respectively. Updates of basis and sorting are denoted, respectively, by  $\Theta \cdot X : t$  and  $\Gamma \cdot y : S$ , where  $X \notin \text{dom}(\Theta)$ ,  $t \notin \text{cod}(\Theta)$  and  $y \notin \text{dom}(\Gamma)$ . The judgement  $\Theta; \Gamma \vdash P \triangleright \Delta$  stands for “under the environment  $\Theta; \Gamma$ , process  $P$  has typing  $\Delta$ ”. In its own turn, the typing of processes relies on auxiliary judgments for expressions, of the form  $\Gamma \vdash e \triangleright S$ . The axioms and rules defining the typing system for cherry-pi collaborations, processes and expressions are given in Fig. 8, 9, and 10, respectively. The type system is defined only for initial collaborations, i.e. for terms generated by the grammar in Fig. 2. Other runtime collaborations are not considered here, as no check will be performed at runtime. We comment on salient points. Typing rules at collaboration level simply collect the type associations of session initiators in the collaboration. Rules at process level instead determine the session type corresponding to each process, by mapping each process operator to the corresponding type operator. Data and expression used in communication actions are abstracted as sorts, and a conditional choice is rendered as an internal non-deterministic choice. Typing rules for expressions are standard.

**4.2. Compliance checking.** To check compliance between pairs of session parties, we consider *type configurations* of the form  $(T, T') : \langle \tilde{T}_1 \rangle \triangleright T_2 \parallel \langle \tilde{T}_3 \rangle \triangleright T_4$ , consisting in a pair  $(T, T')$  of session types, corresponding to the types of the parties at the initiation of the session, and in the parallel composition of two pairs  $\langle \tilde{T}_c \rangle \triangleright T$ , where  $T$  is the session type of a party and  $\tilde{T}_c$  is the type of the party’s checkpoint. We use  $\tilde{T}$  to denote either a type  $T$ , representing a checkpoint committed by the party, or  $\underline{T}$ , representing a checkpoint imposed by the other party. The semantics of type configurations, necessary for the definition of the compliance relation, is given in Fig. 11, where label  $\lambda$  stands for either  $![S]$ ,  $?[S]$ ,  $\triangleleft l$ ,  $\triangleright l$ ,  $\tau$ , `cmt`, `roll`, or `abt`. We comment on the relevant rules. In case of a commit action, the checkpoints of both parties are updated, and the one of the passive party (i.e., the party that has not performed the commit) is marked as ‘imposed’ (rule [TS-CMT<sub>1</sub>]). However, if the passive party did not perform any action from its current checkpoint, this checkpoint is not overwritten by the active party (rule [TS-CMT<sub>2</sub>]), as discussed in Sec. 2 (Fig. 1(c)). In case of a roll action (rule [TS-RLL<sub>1</sub>]), the reduction step is performed only if the active party (i.e., the party that has performed the rollback action) has a non-imposed checkpoint; otherwise, the configuration cannot proceed with the rollback and reduces to an erroneous configuration (rule [TS-RLL<sub>2</sub>]). Finally,

$$\begin{array}{c}
\frac{\Gamma \vdash e \blacktriangleright S \quad \Theta; \Gamma \vdash P \blacktriangleright x : T}{\Theta; \Gamma \vdash x! \langle e \rangle . P \blacktriangleright x : ! [S]. T} \text{ [T-SND]} \quad \frac{\Theta; \Gamma \cdot y : S \vdash P \blacktriangleright x : T}{\Theta; \Gamma \vdash x?(y : S). P \blacktriangleright x : ? [S]. T} \text{ [T-RCV]} \\
\Theta; \Gamma \vdash \mathbf{0} \blacktriangleright x : \text{end} \text{ [T-INACT]} \quad \frac{\Theta; \Gamma \vdash P \blacktriangleright x : T}{\Theta; \Gamma \vdash x \triangleleft l . P \blacktriangleright x : \triangleleft [l]. T} \text{ [T-SEL]} \\
\frac{\Theta; \Gamma \vdash P_1 \blacktriangleright x : T_1 \quad \dots \quad \Theta; \Gamma \vdash P_n \blacktriangleright x : T_n}{\Theta; \Gamma \vdash x \triangleright \{l_1 : P_1, \dots, l_n : P_n\} \blacktriangleright x : \triangleright [l_1 : T_1, \dots, l_n : T_n]} \text{ [T-BR]} \\
\frac{\Gamma \vdash e \blacktriangleright \text{bool} \quad \Theta; \Gamma \vdash P_1 \blacktriangleright x : T_1 \quad \Theta; \Gamma \vdash P_2 \blacktriangleright x : T_2}{\Theta; \Gamma \vdash \text{if } e \text{ then } P_1 \text{ else } P_2 \blacktriangleright x : T_1 \oplus T_2} \text{ [T-IF]} \\
\Theta \cdot X : t; \Gamma \vdash X \blacktriangleright t \text{ [T-PVAR]} \quad \frac{\Theta \cdot X : t; \Gamma \vdash P \blacktriangleright T}{\Theta; \Gamma \vdash \mu X . P \blacktriangleright \mu t . T} \text{ [T-REC]} \\
\frac{\Theta; \Gamma \vdash P \blacktriangleright x : T}{\Theta; \Gamma \vdash \text{commit} . P \blacktriangleright x : \text{cmt} . T} \text{ [T-CMT]} \\
\Theta; \Gamma \vdash \text{roll} \blacktriangleright x : \text{roll} \text{ [T-RLL]} \quad \Theta; \Gamma \vdash \text{abort} \blacktriangleright x : \text{abt} \text{ [T-ABT]}
\end{array}$$

---

Figure 9: Typing system for cherry-pi processes.

$$\begin{array}{c}
\Gamma \vdash \text{true} \blacktriangleright \text{bool} \text{ [T-BOOL}_{tt}] \quad \Gamma \vdash \text{false} \blacktriangleright \text{bool} \text{ [T-BOOL}_{ff}] \\
\Gamma \cdot x : S \vdash x \blacktriangleright S \text{ [T-VAR]} \quad \Gamma \vdash 1 \blacktriangleright \text{int} \text{ [T-INT]} \quad \Gamma \vdash "a" \blacktriangleright \text{str} \text{ [T-STR]} \\
\frac{\Gamma \vdash e_1 \blacktriangleright \text{int} \quad \Gamma \vdash e_2 \blacktriangleright \text{int}}{\Gamma \vdash +(e_1, e_2) \blacktriangleright \text{int}} \text{ [T-SUM]} \quad \frac{\Gamma \vdash e_1 \blacktriangleright \text{bool} \quad \Gamma \vdash e_2 \blacktriangleright \text{bool}}{\Gamma \vdash \wedge(e_1, e_2) \blacktriangleright \text{bool}} \text{ [T-AND]}
\end{array}$$

---

Figure 10: Typing system for cherry-pi expressions (excerpt of rules).

in case of abort (rule [TS-ABT<sub>1</sub>]), the configuration goes back to the initial state; this allows the type computation to proceed, in order not to affect the compliance check between the two parties.

On top of the above type semantics, we define the compliance relation, inspired by the relation in [BDLd16], and prove its decidability.

**Definition 4.1** (Compliance). Relation  $\dashv\!\!\dashv$  on configurations is defined as follows:  $(T, T') : \langle \tilde{U}_1 \rangle \blacktriangleright T_1 \dashv\!\!\dashv \langle \tilde{U}_2 \rangle \blacktriangleright T_2$  holds if for all  $U'_1, T'_1, U'_2, T'_2$  such that  $(T, T') : \langle \tilde{U}_1 \rangle \blacktriangleright T_1 \parallel \langle \tilde{U}_2 \rangle \blacktriangleright T_2 \mapsto^* (T, T') : \langle \tilde{U}'_1 \rangle \blacktriangleright T'_1 \parallel \langle \tilde{U}'_2 \rangle \blacktriangleright T'_2 \not\mapsto$  we have that  $T'_1 = T'_2 = \text{end}$ . Two types  $T_1$  and  $T_2$  are *compliant*, written  $T_1 \dashv\!\!\dashv T_2$ , if  $(T_1, T_2) : \langle T_1 \rangle \blacktriangleright T_1 \dashv\!\!\dashv \langle T_2 \rangle \blacktriangleright T_2$ .

**Theorem 4.2.** *Let  $T_1$  and  $T_2$  be two session types, checking if  $T_1 \dashv\!\!\dashv T_2$  holds is decidable.*

*Proof.* By Def. 4.1, checking  $T_1 \dashv\!\!\dashv T_2$  consists in checking that types  $T'_1$  and  $T'_2$  of each configuration  $(T_1, T_2) : \langle \tilde{U}'_1 \rangle \blacktriangleright T'_1 \parallel \langle \tilde{U}'_2 \rangle \blacktriangleright T'_2$  such that  $(T_1, T_2) : \langle T_1 \rangle \blacktriangleright T_1 \parallel \langle T_2 \rangle \blacktriangleright T_2 \mapsto^* (T_1, T_2) : \langle \tilde{U}'_1 \rangle \blacktriangleright T'_1 \parallel \langle \tilde{U}'_2 \rangle \blacktriangleright T'_2 \not\mapsto$  (i.e., type configurations that are reachable from the initial one and that cannot further evolve) are end types. Thus, to prove that the compliance check is decidable we have to show that the number of these reachable configurations is finite. Let us consider the transition system  $TS = \langle \mathcal{S}, \mathcal{R} \rangle$  associated to the type configuration  $t = (T_1, T_2) : \langle T_1 \rangle \blacktriangleright T_1 \parallel \langle T_2 \rangle \blacktriangleright T_2$  by the reduction semantics of types (Fig. 11): the set  $\mathcal{S}$  of states corresponds to the set of type configurations reachable from  $t$ , i.e.  $\mathcal{S} = \{t' \mid t \mapsto^* t'\}$ , while the set  $\mathcal{R}$  of system transitions corresponds

$$\begin{array}{c}
! [S].T \xrightarrow{! [S]} T \text{ [TS-SND]} \quad ? [S].T \xrightarrow{? [S]} T \text{ [TS-RCV]} \quad \triangleleft [l].T \xrightarrow{\triangleleft l} T \text{ [TS-SEL]} \\
\triangleright [l_1 : T_1, \dots, l_n : T_n] \xrightarrow{\triangleright l_i} T_i \quad (1 \leq i \leq n) \text{ [TS-BR]} \quad \frac{T[\mu t.T/t] \xrightarrow{\lambda} T'}{\mu t.T \xrightarrow{\lambda} T'} \text{ [TS-REC]} \\
T_1 \oplus T_2 \xrightarrow{\tau} T_1 \text{ [TS-IF}_1\text{]} \quad T_1 \oplus T_2 \xrightarrow{\tau} T_2 \text{ [TS-IF}_2\text{]} \\
\text{cmt}.T \xrightarrow{\text{cmt}} T \text{ [TS-CMT]} \quad \text{roll} \xrightarrow{\text{roll}} \text{end} \text{ [TS-RLL]} \quad \text{abt} \xrightarrow{\text{abt}} \text{end} \text{ [TS-ABT]} \\
\frac{T_1 \xrightarrow{\tau} T'_1}{(T, T') : \langle \tilde{U}_1 \rangle \blacktriangleright T_1 \parallel \langle \tilde{U}_2 \rangle \blacktriangleright T_2 \mapsto (T, T') : \langle \tilde{U}_1 \rangle \blacktriangleright T'_1 \parallel \langle \tilde{U}_2 \rangle \blacktriangleright T_2} \text{ [TS-TAU]} \\
\frac{T_1 \xrightarrow{! [S]} T'_1 \quad T_2 \xrightarrow{? [S]} T'_2}{(T, T') : \langle \tilde{U}_1 \rangle \blacktriangleright T_1 \parallel \langle \tilde{U}_2 \rangle \blacktriangleright T_2 \mapsto (T, T') : \langle \tilde{U}_1 \rangle \blacktriangleright T'_1 \parallel \langle \tilde{U}_2 \rangle \blacktriangleright T'_2} \text{ [TS-COM]} \\
\frac{T_1 \xrightarrow{\triangleleft l} T'_1 \quad T_2 \xrightarrow{\triangleright l} T'_2}{(T, T') : \langle \tilde{U}_1 \rangle \blacktriangleright T_1 \parallel \langle \tilde{U}_2 \rangle \blacktriangleright T_2 \mapsto (T, T') : \langle \tilde{U}_1 \rangle \blacktriangleright T'_1 \parallel \langle \tilde{U}_2 \rangle \blacktriangleright T'_2} \text{ [TS-LAB]} \\
\frac{T_1 \xrightarrow{\text{cmt}} T'_1 \quad \tilde{U}_2 \neq T_2}{(T, T') : \langle \tilde{U}_1 \rangle \blacktriangleright T_1 \parallel \langle \tilde{U}_2 \rangle \blacktriangleright T_2 \mapsto (T, T') : \langle \tilde{U}_1 \rangle \blacktriangleright T'_1 \parallel \langle \tilde{U}_2 \rangle \blacktriangleright T_2} \text{ [TS-CMT}_1\text{]} \\
\frac{T_1 \xrightarrow{\text{cmt}} T'_1 \quad \tilde{U}_2 = T_2}{(T, T') : \langle \tilde{U}_1 \rangle \blacktriangleright T_1 \parallel \langle \tilde{U}_2 \rangle \blacktriangleright T_2 \mapsto (T, T') : \langle \tilde{U}_1 \rangle \blacktriangleright T'_1 \parallel \langle \tilde{U}_2 \rangle \blacktriangleright T_2} \text{ [TS-CMT}_2\text{]} \\
\frac{T_1 \xrightarrow{\text{roll}} T'_1}{(T, T') : \langle \underline{U}_1 \rangle \blacktriangleright T_1 \parallel \langle \tilde{U}_2 \rangle \blacktriangleright T_2 \mapsto (T, T') : \langle \underline{U}_1 \rangle \blacktriangleright U_1 \parallel \langle \tilde{U}_2 \rangle \blacktriangleright U_2} \text{ [TS-RLL}_1\text{]} \\
\frac{T_1 \xrightarrow{\text{roll}} T'_1}{(T, T') : \langle \underline{U}_1 \rangle \blacktriangleright T_1 \parallel \langle \tilde{U}_2 \rangle \blacktriangleright T_2 \mapsto (T, T') : \langle \underline{U}_1 \rangle \blacktriangleright \text{err} \parallel \langle \tilde{U}_2 \rangle \blacktriangleright \text{err}} \text{ [TS-RLL}_2\text{]} \\
\frac{T_1 \xrightarrow{\text{abt}} T'_1}{(T, T') : \langle \tilde{U}_1 \rangle \blacktriangleright T_1 \parallel \langle \tilde{U}_2 \rangle \blacktriangleright T_2 \mapsto (T, T') : \langle \tilde{U}_1 \rangle \blacktriangleright T' \parallel \langle \tilde{U}_2 \rangle \blacktriangleright T'} \text{ [TS-ABT}_1\text{]}
\end{array}$$

Figure 11: Semantics of types and type configurations (symmetric rules for configurations are omitted).

to set of the type reductions involving configurations in  $\mathcal{S}$ , i.e.  $\mathcal{R} = \{(t', t'') \in \mathcal{S} \times \mathcal{S} \mid t' \mapsto t''\}$ . Hence, checking  $T_1 \dashv\vdash T_2$  boils down to check the type configurations corresponding to the leaves (i.e., states without outgoing transitions) of  $TS$ . Specifically, given a leaf of  $TS$  corresponding to  $(T_1, T_2) : \langle \tilde{V}_1 \rangle \blacktriangleright V_2 \parallel \langle \tilde{V}_3 \rangle \blacktriangleright V_4$ , we have to check if  $V_2 = V_4 = \text{end}$ . The decidability of this check therefore depends on the finiteness of  $TS$ . This result is ensured by the fact that: (i) backward reductions connect states of  $TS$  only to previously visited states of  $TS$  (Theorem 6.5), and (ii) our language of types (Fig. 7) corresponds to a CCS-like process algebra without static operators (i.e., parallel and restriction operators) within recursion (see [Mil89, Sec. 7.5]).  $\square$

The compliance relation is used to define the notion of *rollback safety*.

**Definition 4.3** (Rollback safety). Let  $C$  be an initial collaboration, then  $C$  is *rollback safe* (shortened *roll-safe*) if  $C \triangleright A$  and for all pairs  $\bar{a} : T_1$  and  $a : T_2$  in  $A$  we have  $T_1 \dashv\vdash T_2$ .

**Example 4.4.** Let us consider again the VOD example. As expected, the first cherry-pi collaboration defined in Ex. 3.1, corresponding to the scenario described in Fig. 1(b), is not rollback safe, because the types of the two parties are not compliant. Indeed, the session types  $T_U$  and  $T_S$  associated by the type system to the user and the service processes, respectively, are as follows:

$$\begin{aligned} T_U &= ![\text{str}].?[\text{int}].\text{cmt}.?[\text{str}].(\langle [l_{HD}].?[\text{str}].(?[\text{str}].\text{end} \oplus \text{roll}) \\ &\quad \oplus \langle [l_{SD}].?[\text{str}].(?[\text{str}].\text{end} \oplus \text{abt}) \rangle) \\ T_S &= ?[\text{str}].![\text{int}].![\text{str}].\triangleright [l_{HD} : \text{cmt}.![\text{str}].![\text{str}].\text{end}, \\ &\quad l_{SD} : \text{cmt}.![\text{str}].![\text{str}].\text{end}] \end{aligned}$$

Thus, the resulting initial configuration is  $(T_U, T_S) : \langle T_U \rangle \triangleright T_U \parallel \langle T_S \rangle \triangleright T_S$ , which can evolve to the configuration  $(T_U, T_S) : \langle T \rangle \triangleright \text{roll} \parallel \langle U \rangle \triangleright ![\text{str}].\text{end}$ , with  $T = ?[\text{str}].(?[\text{str}].\text{end} \oplus \text{roll})$  and  $U = ![\text{str}].![\text{str}].\text{end}$ . This configuration evolves to  $(T_U, T_S) : \langle T \rangle \triangleright \text{err} \parallel \langle U \rangle \triangleright \text{err}$ , which cannot further evolve and is not in a completed state (in fact, type `err` is different from `end`), meaning that  $T_U$  and  $T_S$  are not compliant.

In the scenario described in Fig. 1(c), instead, the type of the server process is as follows:  $T'_S = ?[\text{str}].![\text{int}].\text{cmt}.![\text{str}].\triangleright [l_{HD} : ![\text{str}].![\text{str}].\text{end}, l_{SD} : ![\text{str}].![\text{str}].\text{end}]$  and we have  $T_U \dashv\vdash T'_S$ . Finally, the types of the processes depicted in Fig. 1(d) are:

$$\begin{aligned} T'_U &= ![\text{str}].?[\text{int}].?[\text{str}].\text{cmt}.(\langle [l_{HD}]. \dots \oplus \langle [l_{SD}]. \dots \rangle) \\ T''_S &= ?[\text{str}].![\text{int}].![\text{str}].\text{cmt}. \triangleright [l_{HD} : ![\text{str}].![\text{str}].\text{end}, l_{SD} : ![\text{str}].![\text{str}].\text{end}] \end{aligned}$$

and we have  $T'_U \dashv\vdash T''_S$ . Indeed, the corresponding initial configuration can evolve to the configuration  $(T'_U, T''_S) : \langle \langle [l_{HD}]. \dots \rangle \triangleright \text{roll} \parallel \langle \triangleright [l_{HD} : \dots, l_{SD} : \dots] \rangle \triangleright ![\text{str}].\text{end}$ , which again evolves to a configuration that is not in a completed state.

## 5. MAUDE IMPLEMENTATION.

To show the feasibility of our approach, we have implemented the semantics of type configurations in Fig. 11 in the MAUDE framework [CDE<sup>+</sup>07]. MAUDE provides an instantiation of rewriting logic [Mes92] and it has been used to implement the semantics of several formal languages [Mes12].

The syntax of cherry-pi types and type configurations is specified by defining algebraic data types, while transitions and reductions are rendered as rewrites and, hence, inference rules are given in terms of (conditional) rewrite rules. Since MAUDE specifications are executable, we have obtained in this way an interpreter for cherry-pi type configurations, which permits to explore the reductions arising from the initial configuration of two given session types.

Our implementation consists of two MAUDE modules. The CHERRY-TYPES-SYNTAX module provides the definition of the sorts that characterise the syntax of cherry-pi types, such as session types, selection/branching labels, type variables and type configurations. In particular, basic terms of session types are rendered as constant *operations* on the sort `Type`; e.g., the `roll` type is defined as

<code>op roll : -&gt; Type .</code>
-------------------------------------

The other syntactic operators are instead defined as operations with one or more arguments; e.g., the output type takes as input a `Sort` and a continuation type:

```
op ![_]._ : Sort Type -> Type [frozen prec 25] .
```

To prevent undesired rewrites inside operator arguments, following the approach in [VMO02], we have declared these operations as `frozen`. The `prec` attribute has been used to define the precedence among operators.

The CHERRY-TYPES-SEMANTICS module provides *rewrite rules*, and additional operators and equations, to define the `cherry-pi` type semantics. For example, the operational rule [TS-SND] is rendered as follows:

```
rl [TS-Snd] : ![S].T => {![S]}T .
```

The correspondence between the operational rule and the rewrite rule is one-to-one; the only peculiarity is the fact that, since rewrites have no labels, we have made the transition label part of the resulting term. Reduction rules for type configurations are instead rendered in terms of conditional rewrite rules with rewrites in their conditions. For example, the [TS-COM] rule is rendered as:

```
cr1 [TS-Com] :
  init(T,T') CT1 > T1 || CT2 > T2 => init(T,T') CT1 > T1' || CT2 > T2'
  if T1 => {![S]}T1' /\ T2 => {?[S]}T2' .
```

Again, there is a close correspondence between the operational rule and the rewrite one.

The compliance check between two session types can be then conveniently realised on top of the implementation described above by resorting to the MAUDE command `search`. This permits indeed to explore the state space of the configurations reachable from an initial configuration. Specifically, the compliance check between types  $T_1$  and  $T_2$  is rendered as follows:

```
search
  init(T1,T2) ckp(T1) > T1 || ckp(T2) > T2
  =>!
  init(T:Type,T':Type) CT1:CkpType > T1':Type || CT2:CkpType > T2':Type
  such that T1' /= end or T2' /= end .
```

This command searches for all terminal states ( $=>!$ ), i.e. states that cannot be rewritten any more (see  $\dashv\rightarrow$  in Def. 4.1), and checks if at least one of the two session types in the corresponding configurations ( $T_1'$  and  $T_2'$ ) is different from the `end` type. Thus, if this search has no solution,  $T_1$  and  $T_2$  are compliant; otherwise, they are not compliant and a violating configuration is returned.

**Example 5.1.** Let us consider the `cherry-pi` types defined in Ex. 4.4 for the scenario described in Fig. 1(b). In our MAUDE implementation of the type syntax, the session types  $T_U$  and  $T_S$ , and the corresponding initial type configuration, are rendered as follows:

```
eq Tuser = ![str]. ?[int]. cmt. ?[str].
           ((sel['hd']. ?[str]. ((?[str]. end) (+) roll))
            (+) (sel['sd']. ?[str]. ((?[str]. end) (+) abt))) .

eq Tservice = ?[str]. ![int]. ![str].
              brn[brnEl('hd, cmt. ![str]. ![str]. end);
               brnEl('sd, cmt. ![str]. ![str]. end)] .

eq InitConfig = init(Tuser,Tservice)
               ckp(Tuser) > Tuser || ckp(Tservice) > Tservice .
```

where `(+)` represents the internal choice operator, `sel` the selection operator, `brn` the branching operator, `brnEl` an option offered in a branching, and `ckp` a non-imposed checkpoint. The compliance between the two session types can be checked by loading the two modules of our MAUDE implementation, and executing the following command:

```

search InitConfig
  =>!
  init(T:Type,T':Type) CT1:CkpType > T1:Type || CT2:CkpType > T2:Type
such that T1 != end or T2 != end .

```

This search command returns the following solution:

```

CT1 --> ickp(?[str]. ((?[str]. end)(+)roll))
T1 --> err
CT2 --> ckp(![str]. ![str]. end)
T2 --> err

```

As explained in Ex. 4.4, the two types are not compliant. Indeed, the configuration above is a terminal state, and T1 and T2 are clearly different from end.

The scenario in Fig. 1(c) is rendered by the following implementation of the service type:

```

eq Tservice' = ?[str]. ![int]. cmt. ![str].
  brn[brnEl('hd, ![str]. ![str]. end);
  brnEl('sd, ![str]. ![str]. end)] .

```

In this case, as expected, the search command returns:

```

No solution.

```

meaning that types Tuser and Tservice' are compliant. Finally, the search command applied to the type configuration related to the scenario depicted in Fig. 1(d) returns a solution, meaning that in that case the user and service types are not compliant.

## 6. PROPERTIES OF cherry-pi

This section presents the results regarding the properties of cherry-pi. The statement of some properties exploits labelled transitions that permit to easily distinguish the execution of commit and rollback actions from the other ones. To this end, we can instrument the reduction semantics of collaborations by means of labels of the form *cmt s*, *roll s* and *abt s*, indicating the rule used to derive the reduction and the session on which such operation has been done. When we do not want to distinguish the applied rule we will write  $C \xrightarrow{s} C'$  to indicate that a reduction is taking place on session *s*.

**6.1. Useful lemmata.** We now introduce a couple of results that will allow us to focus on one session per time, even if there could be multiple concurrent sessions running together. The first of such results tells us that reductions taking place on different sessions can be swapped. Formally:

**Lemma 6.1** (Swap Lemma). *Let  $C$  be a collaboration and  $s$  and  $r$  two sessions. If  $C \xrightarrow{s} C_1 \xrightarrow{r} C_2$  then there exists a collaboration  $C_3$  such that  $C \xrightarrow{r} C_3 \xrightarrow{s} C_2$ .*

*Proof.* By case analysis on the reductions  $\xrightarrow{s}$  and  $\xrightarrow{r}$ . □

All the reductions taking place on a session *s* can be put all together in sequence. Formally:

**Lemma 6.2.** *Let  $C$  be a collaboration. If  $C \xrightarrow{*} C_1$ , then for any session  $s$  in  $C_1$  there exists a collaboration  $C_0$  such that  $C \xrightarrow{*} C_0 \xrightarrow{s} C_1$  and  $s$  is never used in the trace  $C \xrightarrow{*} C_0$ .*

*Proof.* By induction on the number  $n$  of reduction on  $s$ . If there are no reductions then the thesis trivially holds. Otherwise, we can take the very last reduction on  $s$ , that is the closest one to  $C_1$  and iteratively apply Lemma 6.1 in order to bring it to the very end. Then we can conclude by induction on a trace with less occurrences of reductions on  $s$ .  $\square$

Thanks to Lemma 6.2 we can rearrange any trace as a sequence of *independent* sessions. Moreover, given an initial collaboration  $C$ , for any reachable collaboration  $C_1$  and session  $s$  such that  $C \rightarrow^* C_1 \xrightarrow{s}^*$  and  $s \notin \rightarrow^*$ , we indicate  $C_1$  as the *initial* collaboration for  $s$ . This will allow us to focus just on a single session, say  $s$ , and to consider collaboration initial for  $s$  without losing of generality.

**6.2. Rollback properties.** We show some properties concerning the reversible behaviour of cherry-pi related to the interplay between rollback and commit primitives. Notably, Theorem 6.5 and Lemma 6.6, are an adaptation of typical properties of reversible calculi, while Lemma 6.7 and Lemma 6.8 are brand new.

The following two lemmata are the key ingredients for proving Theorem 6.5. Specifically, the former lemma states that an abort leads back to the initial collaboration, while the latter one states that a rollback leads back to the last committed checkpoint.

**Lemma 6.3.** *Let  $C$  be an initial collaboration such that  $C \rightarrow^* C_1$ . If  $C_1 \xrightarrow{abt} C_2$  then  $C_2 \equiv C$ .*

*Proof.* Since  $C$  is *initial*, without losing of generality we can assume  $C \equiv \bar{a}(x_1).P_1 \mid a(x_2).P_2$ . The first reduction of  $C \rightarrow^* C_1$  has to be an application of rule [F-CON], that is

$$\begin{aligned} C &\rightarrow (\nu s : (\bar{a}(x_1).P_1 \mid a(x_2).P_2)) \\ &\quad (\langle P_1[\bar{s}/x_1] \rangle \blacktriangleright P_1[\bar{s}/x_1] \mid \langle P_2[s/x_2] \rangle \blacktriangleright P_2[s/x_2]) = C' \end{aligned}$$

and, by hypothesis,  $C' \rightarrow^* C_1$ . Now, no matter the shape of processes in  $C_1$ , by applying rule [B-ABT], we will go back to  $C$ , that is  $C_1 \xrightarrow{abt} C$ , as desired.  $\square$

**Lemma 6.4.** *Let  $C$  be a reachable collaboration, such that  $C \xrightarrow{cmt} C_1$ . If  $C_1 \rightarrow^* C_2 \xrightarrow{roll} C_3$  and there is no commit in  $C_1 \rightarrow^* C_2$ , then  $C_3 \equiv C_1$ .*

*Proof.* Since  $C$  is a reachable collaboration, this implies it has been generated from an initial collaboration  $C_0$ . Without losing of generality, similarly to the Lemma 6.3's proof, we can assume  $C \equiv (\nu s : C_0)(\langle P_1 \rangle \blacktriangleright P_2 \mid \langle Q_1 \rangle \blacktriangleright Q_2)$ . Therefore, assuming w.l.o.g. that  $P_2$  is the committing process (i.e.,  $P_2 \xrightarrow{cmt} P'_2$ ), we have that  $C_1 = (\nu s : C_0)(\langle P'_2 \rangle \blacktriangleright P'_2 \mid \langle Q_2 \rangle \blacktriangleright Q_2)$ . By hypothesis, there is no commits in  $C_1 \rightarrow^* C_2$ , and this implies that the log part of  $C_1$  will never change. Hence, we have that  $C_2 \equiv (\nu s : C_0)(\langle P'_2 \rangle \blacktriangleright P \mid \langle Q_2 \rangle \blacktriangleright Q)$  for some processes  $P$  and  $Q$ . By applying [B-RLL] we have that  $C_2 \xrightarrow{roll} (\nu s : C_0)(\langle P'_2 \rangle \blacktriangleright P'_2 \mid \langle Q_2 \rangle \blacktriangleright Q_2) \equiv C_1$ , as desired.  $\square$

The following theorem states that any reachable collaboration is also a *forward only* reachable collaboration. This means that all the states a collaboration reaches via mixed executions (also involving backward reductions) are states that we can reach from the initial configuration with just forward reductions. This assures us that if the system goes back it will reach previous visited states.

**Theorem 6.5.** *Let  $C_0$  be an initial collaboration. If  $C_0 \rightarrow^* C_1$  then  $C_0 \rightarrow^* C_1$ .*

*Proof.* By induction on the number  $n$  of backward reductions contained into  $C_0 \rightsquigarrow^* C_1$ . The base case ( $n = 0$ ) trivially holds. In the inductive case, let us take the backward reduction which is the nearest to  $C_0$ . That is:

$$C_0 \rightsquigarrow^* C' \rightsquigarrow C'' \rightsquigarrow^* C_1$$

Depending whether it is an  $\rightsquigarrow^{abt}$  or a  $\rightsquigarrow^{roll}$  we can apply respectively Lemma 6.3 or Lemma 6.4 to obtain a forward trace of the form

$$C_0 \rightsquigarrow^* C'' \rightsquigarrow^* C_1$$

and we can conclude by applying the inductive hypothesis on the obtained trace which contains less backward moves with respect to the original one.  $\square$

We now show a variant of the so-called Loop Lemma [DK04]. In a fully reversible calculus this lemma states that each computational step, either forward or backward, can be undone. Since reversibility in `cherry-pi` is controlled, we have to state that if a reversible step is possible (e.g., a rollback is *enabled*) then the effects of the rollback can be undone.

**Lemma 6.6** (Safe rollback). *Let  $C_1$  and  $C_2$  be reachable collaborations. If  $C_1 \rightsquigarrow C_2$  then  $C_2 \rightsquigarrow^* C_1$ .*

*Proof.* Since  $C_1$  is a reachable collaboration, we have that there exists an initial collaboration  $C_0$  such that  $C_0 \rightsquigarrow^* C_1$ . By applying Theorem 6.5 we can rearrange the trace such that it contains just forward transitions as follows

$$C_0 \rightsquigarrow^* C_1$$

If the backward reduction is obtained by applying [B-ABT], by Lemma 6.3 we have  $C_2 \equiv C_0$ , from which the thesis trivially follows. Instead, if the backward reduction is obtained by applying [B-RLL], we proceed by case analysis depending on the presence of commit reductions in the trace. If they are present, we select the last of such commit, that is we can decompose the trace in the following way:

$$C_0 \rightsquigarrow^* \xrightarrow{cmt} C_{cmt} \rightsquigarrow^* C_1 \rightsquigarrow^{roll} C_2$$

and by applying Lemma 6.4 we have that  $C_2 \rightsquigarrow^* \equiv C_1$  as desired.

In the case there is no commit in the trace, without losing of generality we can assume  $C_0 \equiv \bar{a}(x_1).P_1 \mid a(x_2).P_2$  and we have:

$$C_0 \rightsquigarrow (\nu s : C_0)(\langle P'_1 \rangle \blacktriangleright P'_1 \mid \langle P'_2 \rangle \blacktriangleright P'_2) \rightsquigarrow^* (\nu s : C_0)(\langle P''_1 \rangle \blacktriangleright P''_1 \mid \langle P''_2 \rangle \blacktriangleright P''_2) \equiv C_1$$

By rule [B-RLL], we have  $C_2 \equiv (\nu s : C_0)(\langle P'_1 \rangle \blacktriangleright P'_1 \mid \langle P'_2 \rangle \blacktriangleright P'_2)$ . Thus, we can conclude by noticing that  $C_0 \rightsquigarrow C_2$  is the first reduction in  $C_0 \rightsquigarrow^* C_1$ .  $\square$

A rollback always brings the system to the last taken checkpoint. We recall that, since there may be sessions running in parallel, a collaboration may be able to do different rollbacks within different sessions. Thus, determinism only holds relative to a given session, and rollback within one session has no effect on any other parallel session.

**Lemma 6.7** (Determinism). *Let  $C$  be a reachable collaboration. If  $C \rightsquigarrow^{rolls} C'$  and  $C \rightsquigarrow^{rolls} C''$  then  $C' \equiv C''$ .*

*Proof.* Since  $C$  is a reachable collaboration, it is has been generated by an initial collaboration  $C_0$  of the form  $C_0 = \bar{a}(x).P_1 \mid a(x).P_2$ , and by Theorem 6.5 we have that  $C_0 \rightsquigarrow^* C$ . We distinguish two cases, whether in the trace there has been at least one commit or not. In the first case, we can decompose the trace in such a way to single out the last commit as follows:

$$C_0 \rightsquigarrow^* C_{cmt} \rightsquigarrow^* C$$



so that in the reduction  $C_{cmt} \rightarrow^* C$  there is no commit. If from  $C$  the rollbacks  $C \xrightarrow{\text{roll}s} C'$  and  $C \xrightarrow{\text{roll}s} C''$  are triggered by the same process, the thesis trivially follows. In the other case, we have that:

$$C \equiv (\nu s : C_0)(\langle Q_1 \rangle \blacktriangleright Q'_1 \mid \langle Q_2 \rangle \blacktriangleright Q'_2)$$

with both  $Q'_1$  and  $Q'_2$  able to trigger a rollback. If the roll action is executed by  $Q'_1$ , by applying rule [B-RLL] we have that

$$(\nu s : C_0)(\langle Q_1 \rangle \blacktriangleright Q'_1 \mid \langle Q_2 \rangle \blacktriangleright Q'_2) \xrightarrow{\text{roll}} (\nu s : C_0)(\langle Q_1 \rangle \blacktriangleright Q_1 \mid \langle Q_2 \rangle \blacktriangleright Q_2) \equiv C'$$

If the roll is triggered by  $Q'_2$ , by applying rule [B-RLL] up to structural congruence we have that

$$(\nu s : C_0)(\langle Q_1 \rangle \blacktriangleright Q'_1 \mid \langle Q_2 \rangle \blacktriangleright Q'_2) \xrightarrow{\text{roll}} (\nu s : C_0)(\langle Q_1 \rangle \blacktriangleright Q_1 \mid \langle Q_2 \rangle \blacktriangleright Q_2) \equiv C''$$

We can conclude by noticing that  $C' \equiv C''$ , as desired.  $\square$

The last rollback property states that a collaboration cannot go back to a state prior to the execution of a commit action, that is commits have a persistent effect. Let us note that recursion does not affect this theorem, since at the beginning of a collaboration computation there is always a new session establishment, leading to a stack of past configurations. Hence it is never the case that from a collaboration  $C$  you can reach again  $C$  via forward steps.

**Theorem 6.8** (Commit persistency). *Let  $C$  be a reachable collaboration. If  $C \xrightarrow{\text{cmt}s} C'$  then there exists no  $C''$  such that  $C' \xrightarrow{\text{roll}s} C''$  and  $C'' \rightarrow^+ C$ .*

*Proof.* We proceed by contradiction. Suppose that there exists  $C''$  such that  $C' \xrightarrow{\text{roll}s} C''$  and  $C'' \rightarrow^+ C$ . Since  $C$  is a reachable collaboration, thanks to Theorem 6.5 we have that there exists an initial collaboration  $C_0$  such that  $C_0 \rightarrow^* C \xrightarrow{\text{cmt}s} C'$ . Since a rollback brings back the collaboration to a point before a commit, this means it has been restored a checkpoint committed before the last one (by [B-RLL], indeed, only processes stored in logs can be restored). This implies that there exist at least two different commits in the trace such that

$$C_0 \rightarrow^* \xrightarrow{\text{cmt}s} C_{cmt} \rightarrow^* C \xrightarrow{\text{cmt}s} C' \rightarrow^* C_{rl} \xrightarrow{\text{roll}s} C''$$

with  $C'' = C_{cmt}$ . Now, consider the commit performed by  $C$ , supposing that it is triggered by  $P_c$  evolving to  $P'_c$  in doing that, we have that:

$$C \equiv (\nu s : C_0)(\langle P \rangle \blacktriangleright P_c \mid \langle Q \rangle \blacktriangleright Q_c) \text{ and } C' = (\nu s : C_0)(\langle P'_c \rangle \blacktriangleright P'_c \mid \langle Q_c \rangle \blacktriangleright Q_c)$$

Now, let us consider the case where  $C' \rightarrow^* C_{rl}$  without any commit being present in the trace, hence:

$$C_{rl} \equiv (\nu s : C_0)(\langle P'_c \rangle \blacktriangleright P_{rl} \mid \langle Q_c \rangle \blacktriangleright Q_{rl})$$

By hypothesis, from  $C_{rl}$  a rollback is possible. Regardless the rollback is triggered by  $P_{rl}$  or  $Q_{rl}$ , we have that  $C_{rl} \xrightarrow{\text{roll}} C'$ , hence  $C' \equiv C''$ . Now, from  $C'$  we cannot reach  $C$  (i.e.,  $C' \not\rightarrow^+ C$ ), as  $C'$  is derived from  $C$  and the rollback can only bring the collaboration back to  $C'$ . Therefore, we have  $C'' \not\rightarrow^+ C$ , which violates the initial hypothesis.

Let us consider, instead, the case where  $C' \rightarrow^* C_{rl}$  with at least a commit being present in the trace. By applying rule [B-RLL], from  $C_{rl}$  the rollback will lead to the last committed collaboration  $C'_{cmt}$  such that  $C' \rightarrow^* \xrightarrow{\text{cmt}s} C'_{cmt} \rightarrow^* C_{rl}$ . Hence,  $C'_{cmt} \equiv C''$  and, like in the previous case, from  $C'_{cmt}$  we cannot reach  $C$ . Again we have  $C'' \not\rightarrow^+ C$ , which violates the initial hypothesis. Therefore, in each case the initial hypothesis is violated, and hence we conclude.  $\square$

$$\begin{array}{c}
\frac{P_1 \xrightarrow{k!(v)} P'_1 \quad \neg P_2 \Downarrow_{k?} \quad \neg P_2 \Downarrow_{roll}}{\langle \tilde{Q}_1 \rangle \blacktriangleright P_1 \mid \langle \tilde{Q}_2 \rangle \blacktriangleright P_2 \rightarrow \text{com\_error}} \quad [\text{E-COM}_1] \quad \frac{P_1 \xrightarrow{k?(x)} P'_1 \quad \neg P_2 \Downarrow_{k!} \quad \neg P_2 \Downarrow_{roll}}{\langle \tilde{Q}_1 \rangle \blacktriangleright P_1 \mid \langle \tilde{Q}_2 \rangle \blacktriangleright P_2 \rightarrow \text{com\_error}} \quad [\text{E-COM}_2] \\
\frac{P_1 \xrightarrow{k<l} P'_1 \quad \neg P_2 \Downarrow_{k>l} \quad \neg P_2 \Downarrow_{roll}}{\langle \tilde{Q}_1 \rangle \blacktriangleright P_1 \mid \langle \tilde{Q}_2 \rangle \blacktriangleright P_2 \rightarrow \text{com\_error}} \quad [\text{E-LAB}_1] \quad \frac{P_1 \xrightarrow{k>l} P'_1 \quad \neg P_2 \Downarrow_{k<l} \quad \neg P_2 \Downarrow_{roll}}{\langle \tilde{Q}_1 \rangle \blacktriangleright P_1 \mid \langle \tilde{Q}_2 \rangle \blacktriangleright P_2 \rightarrow \text{com\_error}} \quad [\text{E-LAB}_2] \\
\frac{P_1 \xrightarrow{cmt} P'_1 \quad \tilde{Q}_2 \neq P_2}{\langle \tilde{Q}_1 \rangle \blacktriangleright P_1 \mid \langle \tilde{Q}_2 \rangle \blacktriangleright P_2 \rightarrow \langle P'_1 \rangle \blacktriangleright P'_1 \mid \langle P_2 \rangle \blacktriangleright P_2} \quad [\text{E-CMT}_1] \\
\frac{P_1 \xrightarrow{cmt} P'_1 \quad \tilde{Q}_2 = P_2}{\langle \tilde{Q}_1 \rangle \blacktriangleright P_1 \mid \langle \tilde{Q}_2 \rangle \blacktriangleright P_2 \rightarrow \langle P'_1 \rangle \blacktriangleright P'_1 \mid \langle \tilde{Q}_2 \rangle \blacktriangleright P_2} \quad [\text{E-CMT}_2] \\
\frac{P_1 \xrightarrow{roll} P'_1}{\langle \tilde{Q}_1 \rangle \blacktriangleright P_1 \mid \langle \tilde{Q}_2 \rangle \blacktriangleright P_2 \rightsquigarrow \langle Q_1 \rangle \blacktriangleright Q_1 \mid \langle \tilde{Q}_2 \rangle \blacktriangleright Q_2} \quad [\text{E-RLL}_1] \\
\frac{P_1 \xrightarrow{roll} P'_1}{\langle \tilde{Q}_1 \rangle \blacktriangleright P_1 \mid \langle \tilde{Q}_2 \rangle \blacktriangleright P_2 \rightarrow \text{roll\_error}} \quad [\text{E-RLL}_2]
\end{array}$$

---

Figure 12: cherry-pi semantics: error reductions.

**6.3. Soundness properties.** The second group of properties concerns soundness guarantees. The definition of these properties requires formally characterising the errors that may occur in the execution of an unsound collaboration. We rely on error reduction (as in [CDSY17]) rather than on the usual static characterisation of errors (as, e.g., in [YV07]), since rollback errors cannot be easily detected statically. In particular, we extend the syntax of cherry-pi collaborations with the `roll_error` and `com_error` terms, denoting respectively collaborations in rollback and communication error states:

$$C ::= \dots \mid \langle \tilde{P}_1 \rangle \blacktriangleright P_2 \mid \text{roll\_error} \mid \text{com\_error}$$

where  $\tilde{P}$  denotes either a checkpoint  $P$  committed by the party or a checkpoint  $\underline{P}$  imposed by the other party of the session.

The semantics of cherry-pi is extended as well by the additional error reduction rules in Fig. 12, where [E-CMT<sub>1</sub>] and [E-CMT<sub>2</sub>] replace [F-CMT], and [E-RLL<sub>1</sub>] replaces [B-RLL]; moreover,  $\tilde{\cdot}$  is used in the checkpoints of the other rules. The error semantics does not affect the normal behaviour of cherry-pi specifications, but it is crucial for stating our soundness theorems. Its definition is based on the notion of *barb* predicate:  $P \Downarrow_\mu$  holds if there exists  $P'$  such that  $P \Rightarrow P'$  and  $P'$  can perform an action  $\mu$ , where  $\mu$  stands for  $k?$ ,  $k!$ ,  $k < l$ ,  $k > l$ , or *roll* (i.e., input, output, select, branching action along session channel  $k$ , or roll action);  $\Rightarrow$  is the reflexive and transitive closure of  $\xrightarrow{\tau}$ . The meaning of the error semantics rules is as follows. A *communication error* takes place in a collaboration when a session participant is willing to perform an output but the other participant is ready to perform neither the corresponding input nor a roll back (rule [E-COM<sub>1</sub>]) or vice versa (rule [E-COM<sub>2</sub>]), or one participant is willing to perform a selection but the corresponding branching is not available on the other side (rule [E-LAB<sub>1</sub>]) or viceversa (rule [E-LAB<sub>2</sub>]). Instead, a *rollback error* takes place in a collaboration when a participant is willing to perform a rollback action but her checkpoint has been imposed by the other participant (rule [E-RLL<sub>2</sub>]). To enable this error check, the rules for commit and rollback (rules [E-CMT<sub>1</sub>], [E-CMT<sub>2</sub>], and [E-RLL<sub>1</sub>]) have been modified

to keep track of imposed overwriting of checkpoints. This information is not relevant for the runtime execution of processes, but it is necessary for characterising the rollback errors that our type-based approach prevents.

Besides defining the error semantics, we also need to define erroneous collaborations, based on the following notion of context:  $\mathbb{C} ::= [\cdot] \mid \mathbb{C} \mid C \mid (\nu s : C) \mathbb{C}$ .

**Definition 6.9** (Erroneous collaborations). A collaboration  $C$  is *communication* (resp. *rollback*) *erroneous* if  $C = \mathbb{C}[\text{com\_error}]$  (resp.  $C = \mathbb{C}[\text{roll\_error}]$ ).

The key soundness results follow: a rollback safe collaboration never reduces to either a rollback erroneous collaboration (Theorem 6.10) or a communication erroneous collaboration (Theorem 6.11).

**Theorem 6.10** (Rollback soundness). *If  $C$  is a roll-safe collaboration, then we have that  $C \not\rightarrow^* \mathbb{C}[\text{roll\_error}]$ .*

*Proof (sketch).* The proof proceeds by contradiction (the full proof is reported in Appendix A).

**Theorem 6.11** (Communication soundness). *If  $C$  is a roll-safe collaboration, then we have that  $C \not\rightarrow^* \mathbb{C}[\text{com\_error}]$ .*

*Proof (sketch).* The proof proceeds by contradiction (the full proof is reported in Appendix A).

We conclude with a progress property of cherry-pi sessions: given a rollback safe collaboration that can initiate a session, each collaboration reachable from it either is able to progress on the session with a forward/backward reduction step or has correctly reached the end of the session. This result follows from Theorems 6.10 and 6.11, and from the fact that we consider binary sessions without delegation and subordinate sessions.

**Theorem 6.12** (Session progress). *Let  $C = (\bar{a}(x_1).P_1 \mid a(x_2).P_2)$  be a roll-safe collaboration. If  $C \rightarrow^* C'$  then either  $C' \rightarrow C''$  for some  $C''$  or  $C' \equiv (\nu s : C)(\langle \tilde{Q}_1 \rangle \blacktriangleright \mathbf{0} \mid \langle \tilde{Q}_2 \rangle \blacktriangleright \mathbf{0})$  for some  $\tilde{Q}_1$  and  $\tilde{Q}_2$ .*

*Proof.* The proof proceeds by contradiction. Suppose that  $C$  is rollback safe and  $C \rightarrow^* C'$  with  $C' \not\rightarrow$  and  $C' \not\equiv (\nu s : C)(\langle \tilde{Q}_1 \rangle \blacktriangleright \mathbf{0} \mid \langle \tilde{Q}_2 \rangle \blacktriangleright \mathbf{0})$  for any  $\tilde{Q}_1$  and  $\tilde{Q}_2$ . The only situations that prevents  $C'$  from progressing are  $C' = \mathbb{C}[\text{roll\_error}]$  or  $C' = \mathbb{C}[\text{com\_error}]$ . However, from Theorems 6.10 and 6.11, respectively, we have  $C' \neq \mathbb{C}[\text{roll\_error}]$  and  $C' \neq \mathbb{C}[\text{com\_error}]$ , which is a contradiction.  $\square$

## 7. cherry-pi AT WORK ON A SPECULATIVE PARALLELISM SCENARIO

To shed light on the practical effectiveness of cherry-pi and the related notion of rollback safety, we consider in this section a simple, yet realistic, scenario concerning a form of speculative execution borrowed from [PRV10]. In this scenario, *value speculation* is used as a mechanism for increasing parallelism, hence system performance, by predicting values of data dependencies between tasks. Whenever a value prediction is incorrect, corrective actions must be taken in order to re-execute the data consumer code with the correct data value. In this regard, as shown in [GLMT17] for a shared-memory setting, reversible execution can permit to relieve programmers from the burden of properly undoing the actions subsequent to an incorrect prediction. Here, we tailor the scenario to the channel-based communication model of session-based programming, and show how our rollback safety checking supports programmers in identifying erroneous rollback recovery settings.

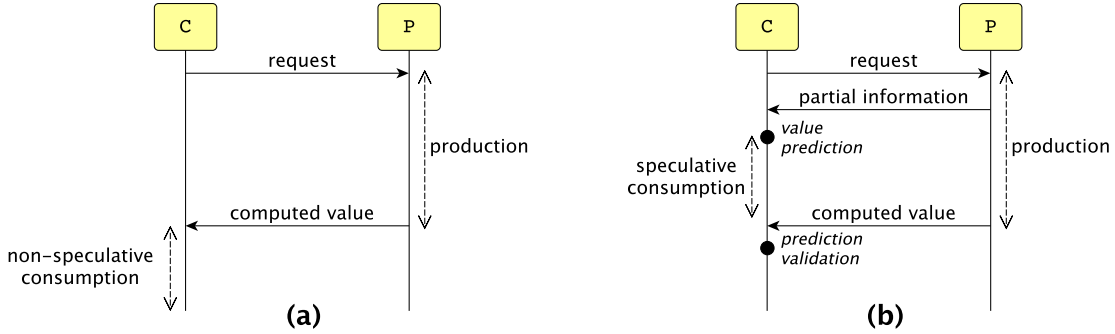

Figure 13: Producer-consumer scenario with non-speculative (a) and speculative (b) consumers.

In the producer-consumer scenario depicted in Fig. 13(a) the session participant  $P$  produces a value and the participant  $C$  consumes it. The data dependence between  $P$  and  $C$  serialises their executions, thus forcing  $C$  to wait for the completion of the value production that requires a fairly long time. In the scenario in Fig. 13(b), instead,  $C$  enacts a speculative behaviour, as it predicts ahead of time the value computed by  $P$  from a partial information. By using the predicted value,  $C$  can execute speculatively and concurrently with  $P$ . When  $P$  completes the production,  $C$  validates the prediction by comparing the actual value computed by  $P$  and the predicted one; if the prediction is precise, we gain performance because the execution of  $C$  and  $P$  overlapped in time, otherwise rollback is used to move  $C$  and  $P$  back to a state that precedes the speculative behaviour, in order to re-execute  $C$  using the correct value. The behaviours of  $C$  and  $P$  can be recursively defined in order to repeat the overall execution once a value is correctly consumed.

The scenario informally described above is rendered in *cherry-pi* as

$$\overline{start}(x).P_C \mid start(y).P_P$$

where the consumer and producer processes are:

$$P_C = \mu X. x! \langle f_{req}() \rangle. x \triangleright \{ l_{spec} : x?(x_{partial} : \text{str}). x?(x_{final} : \text{str}). \\ \text{if } (f_{compare}(x_{partial}, x_{final})) \text{ then roll else commit. } X, \\ l_{nonSpec} : x?(x_{computed} : \text{str}). \text{commit. } X \}$$

$$P_P = \mu Y. y?(y_{req} : \text{str}). \\ \text{if } (f_{eval}(y_{req})) \text{ then } y \triangleleft l_{spec}. y! \langle f_{partial}(y_{req}) \rangle. y! \langle f_{final}(y_{req}) \rangle. Y \\ \text{else } y \triangleleft l_{nonSpec}. y! \langle f_{compute}(y_{req}) \rangle. Y$$

The producer evaluates each consumer's request in order to establish whether to provide directly the produced value or the partial information for the prediction. In the former case the consumer commits the session and both participants restart, while in the latter one the consumer commits or rolls back depending on the result of the comparison between the predicted value and the produced one.

To check whether the above collaboration is rollback safe, we have to check compliance between the session types of the two parties. The session types  $T_C$  and  $T_P$  associated by the type system to the consumer and the producer processes, respectively, and the corresponding initial type configuration are as follows (hereafter we use the MAUDE implementation of the *cherry-pi* type syntax):

```

eq Tc = mu X . ![str]. brn[brnEl('spec', ?[str]. ?[str]. (roll (+) (cmt. X)));
      brnEl('nonSpec', ?[str]. cmt. X)] .

```

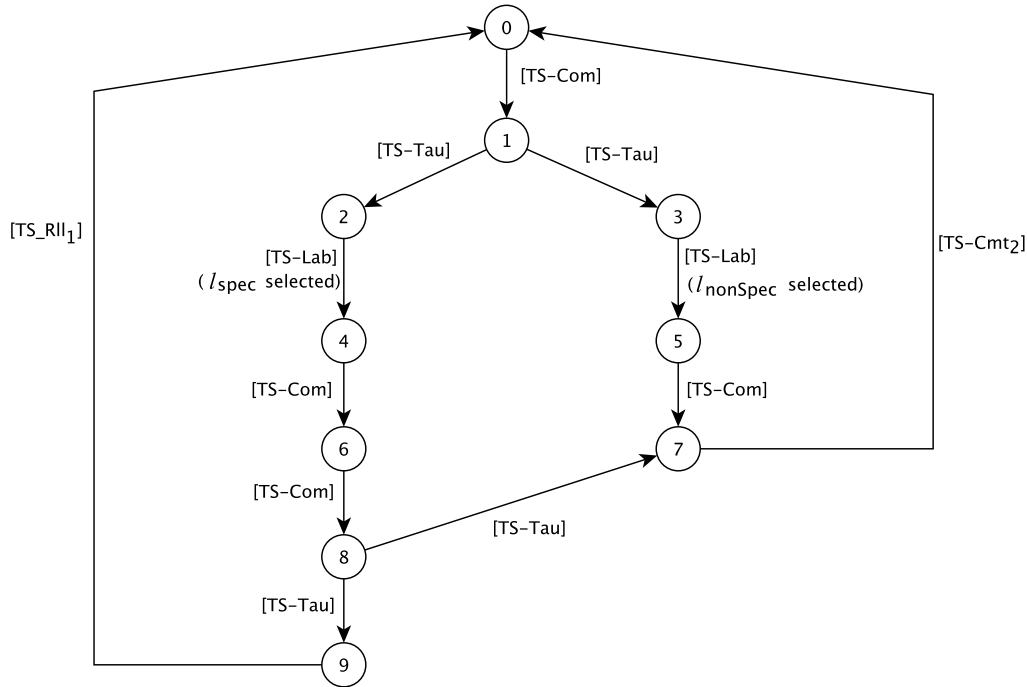

Figure 14: Transition system of the type configuration `CPInitConfig`.

```

eq Tp = mu Y . ?[str]. ((sel['spec']. ![str]. ![str]. Y) (+) (sel['nonSpec']. ![str]. Y)) .
eq CPInitConfig = init(Tc,Tp) ckp(Tc) > Tc || ckp(Tp) > Tp .
  
```

As discussed in Sec. 5, the compliance check for the above type specification is performed by resorting to the MAUDE command `search` as follows:

```

search
  CPInitConfig
  =>!
  init(T:Type,T':Type) CT1:CkpType > T1:Type || CT2:CkpType > T2:Type
  such that T1 != end or T2 != end .
  
```

The above command returns:

```
No solution.
```

meaning that the producer-consumer collaboration is rollback safe. To investigate more in detail the behaviour of this collaboration, we can generate the transition system associated to the type configuration `CPInitConfig` by using the following MAUDE commands:

```

search CPInitConfig =>* C:Configuration .
show search graph .
  
```

The first command searches for all states of the transition, reachable in none, one, or more steps, while the second command returns the current search graph generated by the previous search command. A graphical representation of the generated graph is reported in Fig. 14, where states represent the reachable type configurations (state 0 corresponds to `CPInitConfig`) and transitions are labelled by the applied rules (from Figure 11). Notably, in case a value is correctly consumed, since the

commit action is performed at the end of the recursive step, the type configuration resulting from the commit coincides with the initial one (see transition from state 7 to state 0 in the graph), as both consumer and producer are ready to repeat their interactions for a new value. In case of incorrect prediction (transition from state 8 to state 9), instead, the session execution is moved back to the last checkpoint (transition from state 9 to state 0), corresponding to the successfully consumption of the previous requested value that, at type level, correspond again to the initial type configuration. Indeed, as previously discussed, no commit occurs during the speculative consumption, hence no checkpoint has been created after the one recorded at the end of the previous recursive step. It is worth noticing that in case the prediction of the first produced value is wrong, and hence no commit action is performed by the consumer yet, according to the *cherry-pi* semantics the checkpoint corresponds to the beginning of the session.

Let us consider now a variant of the above scenario where the producer commits each time a value production is completed, which could apparently seem a reasonable behaviour from the producer side. The session type  $T_{p'}$  of such a producer process and the corresponding initial type configuration are as follows:

```

eq Tp' = mu Y . ?[str]. ((sel['spec']. ![str]. ![str]. cmt. Y)
                        (+) (sel['nonSpec']. ![str]. cmt. Y)) .
eq CPInitConfig' = init(Tc, Tp') ckp(Tc) > Tc || ckp(Tp') > Tp' .

```

This time the collaboration is not rollback safe. Indeed, the compliance check returns two solutions:

```

Solution 1 (state 16)
CT1 --> ickp(roll)
T1 --> err
CT2 --> ckp(mu Y . ?[str]. ((sel['spec']. ![str]. ![str]. cmt. Y)
                        (+) sel['nonSpec']. ![str]. cmt. Y))
T2 --> err

Solution 2 (state 17)
CT1 --> ickp(roll(+)cmt. mu X . ![str]. brn[brnEl('nonSpec, ?[str]. cmt. X);
                        brnEl('spec, ?[str]. ?[str]. (roll(+)cmt. X))])
T1 --> err
CT2 --> ckp(mu Y . ?[str]. ((sel['spec']. ![str]. ![str]. cmt. Y)
                        (+) sel['nonSpec']. ![str]. cmt. Y))
T2 --> err

```

corresponding to two erroneous configurations. The overall behaviour is graphically depicted by the transition system in Fig. 15, where state 0 corresponds to  $CPInitConfig'$  and states 16 and 17 are the two erroneous configurations above. While the commit action in the non-speculative case (transitions from state 7 to state 10, and from state 9 to state 0), does not affect the compliance between the two session participants, the other commit action (transitions from state 8 to state 12, and from state 11 to state 13), overwrites the checkpoint set by the consumer, making it impossible to re-execute the consumer with the correct value. This situation, undesirable for the consumer, is detected by our compliance check.

## 8. RELATED WORK

In the literature we can distinguish two ways of dealing with rollback: either using explicit rollbacks and implicit commits [LMSS11], or by using explicit commits and spontaneous aborts [DK05, dVKH10]. Differently from these works, we have introduced a way to control reversibility by both *triggering* it and *limiting* its scope. Reversibility is triggered via an explicit rollback primitive (as

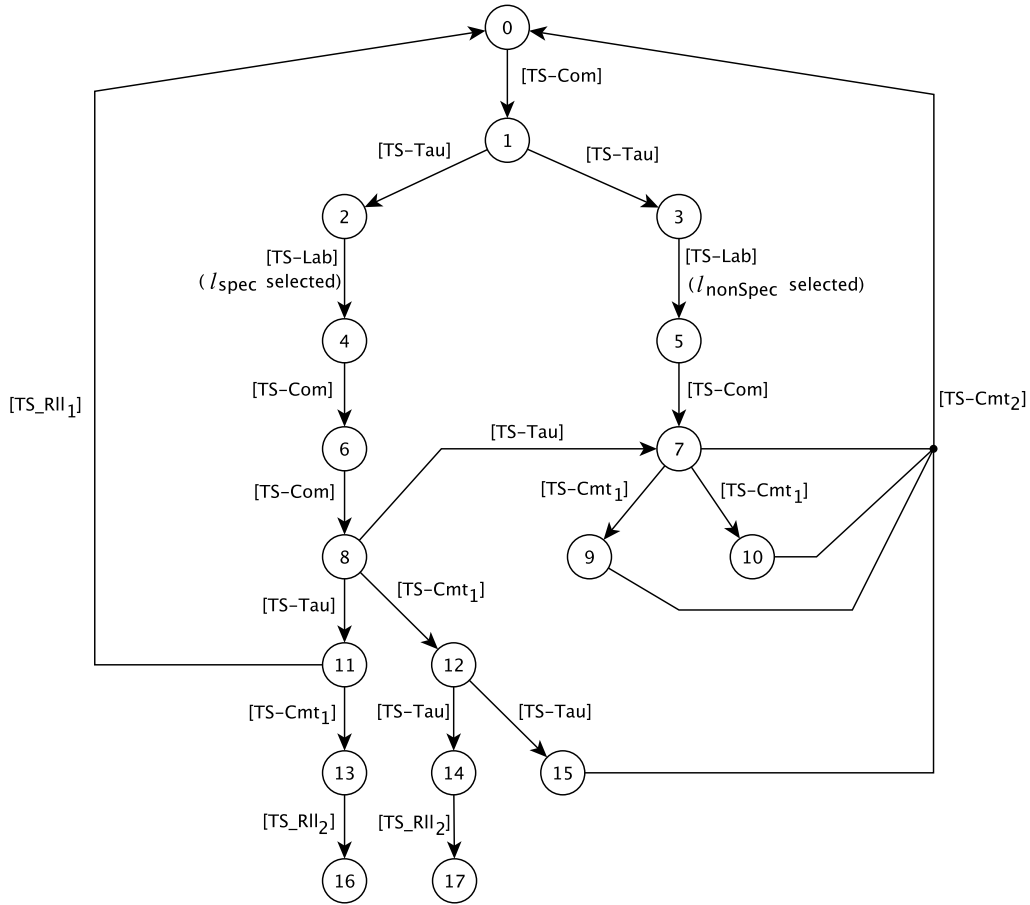

Figure 15: Transition system of the type configuration  $CPInitConfig'$ .

in [LMSS11]), while explicit commits limit the scope of potential future reverse executions (as in [DK05, dVKH10]). Differently from [DK05, dVKH10], commit does not require any synchronisation, as it is a local decision. This could lead to run-time misbehaviours where a process willing to roll back to its last checkpoint reaches a point which has been imposed by another participant of the session. Our type discipline rules out such cases.

Reversibility in behavioural types has been studied in different formalisms: *contracts* [BDd14, BLd17], *binary session types* [MP17], *multiparty session types* [MP21, CDG17, TY15, TY16], and *global graphs* [MT17, FMT18]. In [BDd14, BLd17] choices can be seen as *implicit checkpoints* and the system can go back to a previous choice and try another branch. In [BDd14] rollback is triggered non-deterministically (e.g., it may happen at any time during the execution), while in [BLd17] it is triggered by the system only when the computation is stuck (e.g., the client cannot further continue). In both works reversibility (and rollbacks) is used to achieve a relaxed variant of client-server compliance: if there exists an execution in which the client is able to terminate then the client and server are compliant. Hence, reversibility is used as a means to explore different branches if the current one leads to a deadlock. In [MP17] reversibility is studied in the context of binary session types. Types information is used at run-time by monitors, for binary [MP17] and multiparty [MP21] settings, to keep track of the computational history of the system. allowing to

Work	Formalism	Commit	Rollback	Confined
[LMSS11]	Process Calculi	I	E	N
[DK05]	Process Calculi	E	I	Y
[dVKH10]	Process Calculi	E	I	N
[BDd14, BLd17]	Contracts	I	I	Y
[MP17, MP21]	Session Types	I	I	N
[CDG17]	Session Types	I	I	Y
[MT17, FMT18, FMT20]	Global Graphs	I	E	Y
[Vid23]	Process Calculi	E	E	N
<i>Our work</i>	Process Calculi & Session Types	E	E	N

Table 1: Approaches in the literature; commits and rollbacks can be either implicit (I) or explicit (E); reversibility can be confined (Y) or not (N).

revert any computational step. where global types are enriched with computational history. There, reversibility is uncontrolled, and each computational step can be undone. In [CDG17] global types are enriched with history information, and choices are seen as labelled checkpoints. The information about checkpoints is projected into local types. At any moment, the party who decided which branch to take in a choice may decide to revert it, forcing the entire system to go back to a point prior to the choice. Hence, rollback is confined inside choices and it is spontaneous meaning that the former can be programmed while the latter cannot. Checkpoints are not seen as commits, and a rollback can bring the system to a state prior to several checkpoints. In [TY15] an *uncontrolled* reversible variant of session  $\pi$ -calculus is presented, while [TY16] studies different notions of reversibility for both binary and multiparty single sessions. In [MT17, FMT18, FMT20] global graphs are extended with conditions on branches. These conditions at runtime can trigger coordinated rollbacks to revert a distributed choice. Reversibility is confined into branches of a distributed choice and not all the computational steps are reversible; inputs, in fact, are irreversible unless they are inside an ongoing loop. to trigger a rollback several conditions and constraints about loops have to be satisfied. Hence, in order to trigger a rollback a runtime condition should be satisfied.

The closest work in the literature to ours is [Vid23] where a checkpoint rollback facility is studied on top a reversible actor bases language. Here, checkpoint and rollbacks primitives are explicit, as in our approach. Also, the proposed approach scales with dynamically created processes (e.g., spawning), while we do not deal with this issue. On the other hand, [Vid23] does not deal with ruling out undesired behaviours.

Table 1 summarises all the approaches in the literature. We detach from these works in several ways. Our checkpoint facility is explicit and checkpointing is not confined to choices: the programmer can decide at any point when to commit. This is because the programmer may be interested in committing, besides choice points, a series of interactions (e.g., to make a payment irreversible). Once a commit is taken, the system cannot revert to a state prior to it. Our rollback is explicit, meaning that it is the programmer who deliberately triggers a rollback. Our compliance check, which is decidable, resembles those of [BDd14, BDLd16, BLd17], which are defined for different rollback recovery approaches based on implicit checkpoints.

Concerning the MAUDE implementation of the compliance check, we have followed the approach of the seminal work by Verdejo and Martí-Oliet [VMO02], providing the state-of-the-art implementation of CCS in MAUDE. Along the same line, many other MAUDE implementations of formalisms and languages have been proposed, such as BPMN [CFP<sup>+</sup>18], Twitlang [MPST17], SCEL [BDVW14], and QFLan [VtBLL18].



## 9. CONCLUDING REMARKS

This paper proposes rollback recovery primitives for session-based programming. These primitives come together with session typing, enabling a design time compliance check which ensures checkpoint persistency properties (Lemma 6.6 and Theorem 6.8) and session soundness (Theorems 6.10 and 6.11). Our compliance check has been implemented in MAUDE.

As future work, we plan to extend our approach to deal with sessions where parties can interleave interactions performed along different sessions. This requires to deal with subordinate sessions, which may affect enclosing sessions by performing, e.g., commit actions that make some interaction of the enclosing sessions irreversible, similarly to nested transactions [WS92]. To tackle this issue it would be necessary to extend the notion of compliance relation to take into account possible partial commits (in case of nested sub-sessions) that could be undone at the top level if a rollback is performed. Also, the way our checkpoints are taken resembles the Communication Induced Checkpoints (CIC) approach [EAWJ02]; we leave as future work a thoughtful comparison between these two mechanisms.

We leave as future work the extension of the proposed approach to the multiparty realm, possibly considering fine-grained committing strategies when several parties are involved.

## REFERENCES

- [ACG<sup>+</sup>20] Bogdan Aman, Gabriel Ciobanu, Robert Glück, Robin Kaarsgaard, Jarkko Kari, Martin Kutrib, Ivan Lanese, Claudio Antares Mezzina, Lukasz Mikulski, Rajagopal Nagarajan, Iain C. C. Phillips, G. Michele Pinna, Luca Prigioniero, Irek Ulidowski, and Germán Vidal. Foundations of reversible computation. In Irek Ulidowski, Ivan Lanese, Ulrik Pagh Schultz, and Carla Ferreira, editors, *Reversible Computation: Extending Horizons of Computing - Selected Results of the COST Action IC1405*, volume 12070 of *Lecture Notes in Computer Science*, pages 1–40. Springer, 2020.
- [BDd14] Franco Barbanera, Mariangiola Dezani-Ciancaglini, and Ugo de’Liguoro. Compliance for reversible client/server interactions. In *BEAT*, volume 162 of *EPTCS*, pages 35–42, 2014.
- [BDLd16] Franco Barbanera, Mariangiola Dezani-Ciancaglini, Ivan Lanese, and Ugo de’Liguoro. Retractable contracts. In *PLACES 2015*, volume 203 of *EPTCS*, pages 61–72, 2016.
- [BDVW14] Lenz Belzner, Rocco De Nicola, Andrea Vandin, and Martin Wirsing. Reasoning (on) service component ensembles in rewriting logic. In *Specification, Algebra, and Software*, volume 8373 of *LNCS*, pages 188–211. Springer, 2014.
- [BLd17] Franco Barbanera, Ivan Lanese, and Ugo de’Liguoro. Retractable and speculative contracts. In *COORDINATION*, volume 10319 of *LNCS*, pages 119–137. Springer, 2017.
- [BLd18] Franco Barbanera, Ivan Lanese, and Ugo de’Liguoro. A theory of retractable and speculative contracts. *Sci. Comput. Program.*, 167:25–50, 2018.
- [CDE<sup>+</sup>07] Manuel Clavel, Francisco Durán, Steven Eker, Patrick Lincoln, Narciso Martí-Oliet, José Meseguer, and Carolyn L. Talcott, editors. *All About Maude - A High-Performance Logical Framework, How to Specify, Program and Verify Systems in Rewriting Logic*, volume 4350 of *LNCS*. Springer, 2007.
- [CDG17] Ilaria Castellani, Mariangiola Dezani-Ciancaglini, and Paola Giannini. Concurrent reversible sessions. In *CONCUR*, volume 85 of *LIPICs*, pages 30:1–30:17. Schloss Dagstuhl - Leibniz-Zentrum fuer Informatik, 2017.
- [CDSY17] Tzu-Chun Chen, Mariangiola Dezani-Ciancaglini, Alceste Scalas, and Nobuko Yoshida. On the preciseness of subtyping in session types. *Logical Methods in Computer Science*, 13(2), 2017.
- [CFP<sup>+</sup>18] Flavio Corradini, Fabrizio Fornari, Andrea Polini, Barbara Re, and Francesco Tiezzi. A formal approach to modeling and verification of business process collaborations. *Sci. Comput. Program.*, 166:35–70, 2018.
- [CKV13] Ioana Cristescu, Jean Krivine, and Daniele Varacca. A Compositional Semantics for the Reversible p-Calculus. In *LICS*, pages 388–397. IEEE, 2013.
- [DK04] Vincent Danos and Jean Krivine. Reversible communicating systems. In *CONCUR*, volume 3170 of *LNCS*, pages 292–307. Springer, 2004.
- [DK05] Vincent Danos and Jean Krivine. Transactions in rccs. In *CONCUR*, volume 3653 of *LNCS*, pages 398–412. Springer, 2005.

- [dVKH10] Edsko de Vries, Vasileios Koutavas, and Matthew Hennessy. Communicating transactions - (extended abstract). In Paul Gastin and François Laroussinie, editors, *CONCUR*, volume 6269 of *LNCS*. Springer, 2010.
- [EAWJ02] E. N. Elnozahy, Lorenzo Alvisi, Yi-Min Wang, and David B. Johnson. A survey of rollback-recovery protocols in message-passing systems. *ACM Comput. Surv.*, 34(3):375–408, 2002.
- [Eng12] J. Engblom. A review of reverse debugging. In *System, Software, SoC and Silicon Debug Conference (S4D)*, pages 1–6, Sept 2012.
- [FMT18] Adrian Francalanza, Claudio Antares Mezzina, and Emilio Tuosto. Reversible choreographies via monitoring in erlang. In Silvia Bonomi and Etienne Rivière, editors, *Distributed Applications and Interoperable Systems - 18th IFIP WG 6.1 International Conference, DAIS 2018*, volume 10853 of *Lecture Notes in Computer Science*, pages 75–92. Springer, 2018.
- [FMT20] Adrian Francalanza, Claudio Antares Mezzina, and Emilio Tuosto. Towards choreographic-based monitoring. In *Reversible Computation: Extending Horizons of Computing - Selected Results of the COST Action IC1405*, volume 12070 of *Lecture Notes in Computer Science*, pages 128–150. Springer, 2020. doi:10.1007/978-3-030-47361-7\_6.
- [GLM14] Elena Giachino, Ivan Lanese, and Claudio Antares Mezzina. Causal-consistent reversible debugging. In Stefania Gnesi and Arend Rensink, editors, *Fundamental Approaches to Software Engineering - 17th International Conference, FASE 2014*, volume 8411 of *Lecture Notes in Computer Science*, pages 370–384. Springer, 2014. doi:10.1007/978-3-642-54804-8\_26.
- [GLMT17] Elena Giachino, Ivan Lanese, Claudio Antares Mezzina, and Francesco Tiezzi. Causal-consistent rollback in a tuple-based language. *J. Log. Algebr. Meth. Program.*, 88:99–120, 2017.
- [HLV<sup>+</sup>16] Hans Hüttel, Ivan Lanese, Vasco T. Vasconcelos, Luís Caires, Marco Carbone, Pierre-Malo Deniérou, Dimitris Mostros, Luca Padovani, António Ravara, Emilio Tuosto, Hugo Torres Vieira, and Gianluigi Zavattaro. Foundations of session types and behavioural contracts. *ACM Comput. Surv.*, 49(1):3:1–3:36, 2016.
- [HVK98] Kohei Honda, Vasco Thudichum Vasconcelos, and Makoto Kubo. Language primitives and type discipline for structured communication-based programming. In *ESOP*, volume 1381 of *LNCS*, pages 122–138. Springer, 1998.
- [KU18] Stefan Kuhn and Irek Ulidowski. Local reversibility in a calculus of covalent bonding. *Sci. Comput. Program.*, 151:18–47, 2018.
- [LLM<sup>+</sup>13] Ivan Lanese, Michael Lienhardt, Claudio Antares Mezzina, Alan Schmitt, and Jean-Bernard Stefani. Concurrent flexible reversibility. In *ESOP*, volume 7792 of *LNCS*, pages 370–390. Springer, 2013.
- [LMS10] Ivan Lanese, Claudio Antares Mezzina, and Jean-Bernard Stefani. Reversing higher-order pi. In *CONCUR*, volume 6269 of *LNCS*, pages 478–493. Springer, 2010.
- [LMSS11] Ivan Lanese, Claudio Antares Mezzina, Alan Schmitt, and Jean-Bernard Stefani. Controlling Reversibility in Higher-Order Pi. In *CONCUR*, volume 6901 of *LNCS*, pages 297–311. Springer, 2011.
- [LSU22] Ivan Lanese, Ulrik Pagh Schultz, and Irek Ulidowski. Reversible computing in debugging of erlang programs. *IT Prof.*, 24(1):74–80, 2022. doi:10.1109/MITP.2021.3117920.
- [Mes92] José Meseguer. Conditional rewriting logic as a unified model of concurrency. *Theoretical Computer Science*, 96(1):73–155, 1992.
- [Mes12] José Meseguer. Twenty years of rewriting logic. *J. Log. Algebr. Program.*, 81(7-8):721–781, 2012.
- [Mil89] R. Milner. *Communication and concurrency*. Prentice-Hall, 1989.
- [MP17] Claudio Antares Mezzina and Jorge A. Pérez. Reversibility in session-based concurrency: A fresh look. *J. Log. Algebr. Meth. Program.*, 90:2–30, 2017.
- [MP21] Claudio Antares Mezzina and Jorge A. Pérez. Causal consistency for reversible multiparty protocols. *Log. Methods Comput. Sci.*, 17(4), 2021.
- [MPST17] Alessandro Maggi, Marinella Petrocchi, Angelo Spognardi, and Francesco Tiezzi. A language-based approach to modelling and analysis of twitter interactions. *J. Log. Algebr. Meth. Program.*, 87:67–91, 2017.
- [MSG<sup>+</sup>20] Claudio Antares Mezzina, Rudolf Schlatte, Robert Glück, Tue Haulund, James Hoey, Martin Holm Cservenka, Ivan Lanese, Torben A. Mogensen, Harun Siljak, Ulrik Pagh Schultz, and Irek Ulidowski. Software and reversible systems: A survey of recent activities. In *Reversible Computation: Extending Horizons of Computing - Selected Results of the COST Action IC1405*, volume 12070 of *Lecture Notes in Computer Science*, pages 41–59. Springer, 2020.
- [MT17] Claudio Antares Mezzina and Emilio Tuosto. Choreographies for automatic recovery. *CoRR*, abs/1705.09525, 2017. URL: <http://arxiv.org/abs/1705.09525>, arXiv:1705.09525.
- [MTY23] Claudio Antares Mezzina, Francesco Tiezzi, and Nobuko Yoshida. Rollback recovery in session-based programming. In Sung-Shik Jongmans and Antónia Lopes, editors, *Coordination Models and Languages*

- *25th IFIP WG 6.1 International Conference, COORDINATION 2023*, volume 13908 of *Lecture Notes in Computer Science*, pages 195–213. Springer, 2023. doi:10.1007/978-3-031-35361-1\_11.
- [PP13] Kalyan S. Perumalla and Vladimir A. Protopopescu. Reversible simulations of elastic collisions. *ACM Trans. Model. Comput. Simul.*, 23(2):12:1–12:25, 2013.
- [PRV10] Prakash Prabhu, Ganesan Ramalingam, and Kapil Vaswani. Safe programmable speculative parallelism. In Benjamin G. Zorn and Alexander Aiken, editors, *PLDI*, pages 50–61. ACM, 2010.
- [TY15] Francesco Tiezzi and Nobuko Yoshida. Reversible session-based pi-calculus. *J. Log. Algebr. Meth. Program.*, 84(5):684–707, 2015.
- [TY16] Francesco Tiezzi and Nobuko Yoshida. Reversing single sessions. In *RC*, volume 9720 of *LNCS*, pages 52–69. Springer, 2016.
- [Vid23] Germán Vidal. From reversible computation to checkpoint-based rollback recovery for message-passing concurrent programs. In *19th International Conference on Formal Aspects of Component Software FACS 2023*, volume 13908 of *Lecture Notes in Computer Science*. Springer, 2023. to appear.
- [VMO02] Alberto Verdejo and Narciso Martí-Oliet. Implementing CCS in Maude 2. In *WRLA*, volume 71 of *ENTCS*, pages 239–257. Elsevier, 2002.
- [VS18] Martin Vassor and Jean-Bernard Stefani. Checkpoint/rollback vs causally-consistent reversibility. In *Reversible Computation - 10th International Conference, RC 2018*, volume 11106 of *Lecture Notes in Computer Science*, pages 286–303. Springer, 2018.
- [VtBLL18] Andrea Vandin, Maurice H. ter Beek, Axel Legay, and Alberto Lluch-Lafuente. Qflan: A tool for the quantitative analysis of highly reconfigurable systems. In *FM*, volume 10951 of *LNCS*, pages 329–337. Springer, 2018.
- [WS92] Gerhard Weikum and Hans-J. Schek. Concepts and applications of multilevel transactions and open nested transactions. In *Database Transaction Models for Advanced Applications*, pages 515–553. Morgan Kaufmann, 1992.
- [YV07] Nobuko Yoshida and Vasco Thudichum Vasconcelos. Language Primitives and Type Discipline for Structured Communication-Based Programming Revisited: Two Systems for Higher-Order Session Communication. *Electr. Notes Theor. Comp. Sci.*, 171(4):73–93, 2007.

## APPENDIX A. PROOFS

The auxiliary lemmata required to prove the soundness results rely on the following definitions:

- a process  $\tilde{P}$  and a type  $\tilde{T}$  are in *checkpoint accordance* if  $\tilde{P} = P$  implies  $\tilde{T} = T$ , and  $\tilde{P} = \underline{P}$  implies  $\tilde{T} = \underline{T}$ ;
- let  $\ell$  a process label, its *dual label*  $\bar{\ell}$  is defined as follows:  $\overline{k!\langle v \rangle} = k?(x)$  for some  $x$ ,  $\overline{k?(x)} = k!\langle v \rangle$  for some  $v$ ,  $\overline{k \triangleleft l} = k \triangleright l$ ,  $\overline{k \triangleright l} = k \triangleleft l$ ; this notion of duality straightforwardly extends to type labels;
- the function  $tl_\Gamma(\cdot)$ , mapping process labels to type labels under sorting  $\Gamma$ , is defined as follows:  $tl_\Gamma(k!\langle v \rangle) = ![S]$  with  $\Gamma \vdash v \triangleright S$ ,  $tl_\Gamma(k?(x)) = ?[S]$  with  $\Gamma \vdash x \triangleright S$ ,  $tl_\Gamma(k \triangleleft l) = \triangleleft l$ ,  $tl_\Gamma(k \triangleright l) = \triangleright l$ ,  $tl_\Gamma(\text{cmt}) = \text{cmt}$ ,  $tl_\Gamma(\text{roll}) = \text{roll}$ ,  $tl_\Gamma(\text{abt}) = \text{abt}$ , and  $tl_\Gamma(\tau) = \tau$ .

The following lemma states that each reduction of a reachable collaboration corresponds to a reduction of its configuration types.

**Lemma A.1.** *Let  $C = (\nu s : C')(\langle \tilde{P}_1 \rangle \triangleright P_2 \mid \langle \tilde{Q}_1 \rangle \triangleright Q_2)$  be a reachable collaboration, with  $C' = (\bar{a}(x).P \mid a(y).Q)$ ,  $(\emptyset; \emptyset \vdash P \triangleright x : T)$ ,  $(\emptyset; \emptyset \vdash Q \triangleright y : T')$ ,  $T \dashv\vdash T'$ ,  $(\Theta_1; \Gamma_1 \vdash P_1[x/\bar{s}] \triangleright x : T_1)$ ,  $(\Theta_2; \Gamma_2 \vdash P_2[x/\bar{s}] \triangleright x : T_2)$ ,  $(\Theta'_1; \Gamma'_1 \vdash Q_1[y/\bar{s}] \triangleright y : U_1)$ , and  $(\Theta'_2; \Gamma'_2 \vdash Q_2[y/\bar{s}] \triangleright y : U_2)$ . If  $C \mapsto (\nu s : C')(\langle \tilde{P}'_1 \rangle \triangleright P'_2 \mid \langle \tilde{Q}'_1 \rangle \triangleright Q'_2)$  then there exist  $T'_1, T'_2, U'_1, U'_2$  such that  $(T, T') : \langle \tilde{T}_1 \rangle \triangleright T_2 \parallel \langle \tilde{U}_1 \rangle \triangleright U_2 \mapsto (T, T') : \langle \tilde{T}'_1 \rangle \triangleright T'_2 \parallel \langle \tilde{U}'_1 \rangle \triangleright U'_2$  with  $\tilde{P}'_1$  (resp.  $\tilde{Q}'_1$ ) in checkpoint accordance with  $\tilde{T}'_1$  (resp.  $\tilde{U}'_1$ ),  $(\hat{\Theta}_1; \hat{\Gamma}_1 \vdash P'_1[x/\bar{s}] \triangleright x : T'_1)$ ,  $(\hat{\Theta}_2; \hat{\Gamma}_2 \vdash P'_2[x/\bar{s}] \triangleright x : T'_2)$ ,  $(\hat{\Theta}'_1; \hat{\Gamma}'_1 \vdash Q'_1[y/\bar{s}] \triangleright y : U'_1)$ , and  $(\hat{\Theta}'_2; \hat{\Gamma}'_2 \vdash Q'_2[y/\bar{s}] \triangleright y : U'_2)$ .*

*Proof.* We have two cases depending whether the reduction  $\mapsto$  has forward or backward direction.

$(\mapsto = \Rightarrow)$ : From rule [F-RES], we have  $\langle \tilde{P}_1 \rangle \triangleright P_2 \mid \langle \tilde{Q}_1 \rangle \triangleright Q_2 \mapsto \langle \tilde{P}'_1 \rangle \triangleright P'_2 \mid \langle \tilde{Q}'_1 \rangle \triangleright Q'_2$ . We prove the result by case analysis on the last rule applied in the inference of the above reduction.

- [F-COM]. In this case we have  $P_2 \xrightarrow{\bar{s}\langle v \rangle} P'_2$ ,  $Q_2 \xrightarrow{s?(z)} Q'_2$ , with  $Q'_2 = Q''_2[v/z]$ ,  $\tilde{P}'_1 = \tilde{P}_1$  and  $\tilde{Q}'_1 = \tilde{Q}_1$ . Thus,  $P_2[x/\bar{s}] = x!\langle e \rangle.P'_2[x/\bar{s}]$  for some  $e$  such that  $e \downarrow v$ , and  $Q_2[y/\bar{s}] = y?(z : S').Q'_2[y/\bar{s}]$ . By rule [T-SND], we have that  $T_2 = ![S].T'_2$ , with  $\Gamma_2 \vdash e \triangleright S$ , (hence  $\Gamma_2 \vdash v \triangleright S$ ), and  $\Theta_2; \Gamma_2 \vdash P'_2[x/\bar{s}] \triangleright x : T'_2$  (hence  $\hat{\Theta}_2 = \Theta_2$  and  $\hat{\Gamma}_2 = \Gamma_2$ ). Similarly, by rule [T-RCV], we have that  $U_2 = ?[S'].U'_2$  and  $\Theta'_2; \Gamma'_2 \cdot z : S' \vdash Q''_2[y/\bar{s}] \triangleright y : U'_2$  (hence  $\hat{\Theta}'_2 = \Theta'_2$  and  $\hat{\Gamma}'_2 = \Gamma'_2 \cdot z : S'$ ). By rules [TS-SND] and [TS-RCV], we get  $T_2 \xrightarrow{![S]} T'_2$  and  $U_2 \xrightarrow{?[S']} U'_2$ . Now, reasoning by contradiction, let us suppose that  $S \neq S'$ . Thus, the term  $(T, T') : \langle \tilde{T}_1 \rangle \triangleright T_2 \parallel \langle \tilde{U}_1 \rangle \triangleright U_2 \not\mapsto$ , since no rule in Fig. 11 can be applied. However, since  $C$  is a reachable collaboration, this type configuration is originated from  $(T, T') : \langle T \rangle \triangleright T \parallel \langle T' \rangle \triangleright T'$ . By Def. 4.1,  $T \dashv\vdash T'$  implies  $T_2 = U_2 = \text{end}$ , which is a contradiction. Therefore, it holds that  $S = S'$ . Hence, by applying rule [TS-COM] we can conclude.

- [F-LAB], [E-CMT<sub>1</sub>] and [E-CMT<sub>2</sub>]. Similar to the previous case.
- [F-PAR]. In this case we have that  $\langle \tilde{P}_1 \rangle \triangleright P_2 \mapsto \langle \tilde{P}'_1 \rangle \triangleright P'_2$ . Since this transition involves only one log term, it can be inferred only by applying rule [F-IF], from which we have  $P_2 \xrightarrow{\tau} P'_2$  and  $\tilde{P}'_1 = \tilde{P}_1$ . By rule [P-IFT] (the case of rule [P-IFF] is similar), we have  $P_2[x/\bar{s}] = \text{if } e \text{ then } P'_2[x/\bar{s}] \text{ else } R$  with  $e \downarrow \text{true}$ . By rule [T-IF] we get  $T_2 = T'_2 \oplus V$  and  $\Theta_2; \Gamma_2 \vdash P'_2[x/\bar{s}] \triangleright x : T'_2$ . By rule [TS-IF<sub>1</sub>],  $T_2 \xrightarrow{\tau} T'_2$ . By applying rule [TS-TAU] we can conclude.

$(\mapsto = \rightsquigarrow)$ : The reduction can be inferred by applying rule [B-RES] or rule [B-ABT]. Let us consider the former case, the latter is similar. From rule [B-RES], we have  $\langle \tilde{P}_1 \rangle \triangleright P_2 \mid$

$\langle \tilde{Q}_1 \rangle \blacktriangleright Q_2 \rightsquigarrow \langle \tilde{P}'_1 \rangle \blacktriangleright P'_2 \mid \langle \tilde{Q}'_1 \rangle \blacktriangleright Q'_2$ . We prove the result by case analysis on the last rule applied in the inference of the above reduction.

- [B-RLL]. In this case  $P_2 \xrightarrow{\text{roll}} P'_2$ ,  $\tilde{P}'_1 = \tilde{P}_1$ ,  $\tilde{Q}'_1 = \tilde{Q}_1$  and  $Q'_2 = Q_1$ . By rule [P-RLL], we have  $P_2[x/\bar{s}] = \text{roll}$  and  $P'_2[x/\bar{s}] = \mathbf{0}$ . By rule [T-RLL] we get  $T_2 = \text{roll}$ . By hypothesis  $T \dashv\!\!\dashv T'$ , which implies that rule [TS-RLL<sub>2</sub>] is not applicable, because by Def. 4.1 an erroneous type configuration cannot be reached. Hence, by rule [TS-RLL<sub>1</sub>],  $T_2 \xrightarrow{\text{roll}} T'_2$ , with  $T'_2 = \text{end}$ . By rule [T-INACT], we have  $\Theta_2; \Gamma_2 \vdash P'_2[x/\bar{s}] \blacktriangleright x : T'_2$ . Finally, by applying rule [TS-RLL<sub>1</sub>] we can conclude.
- [B-PAR]. Similarly to the forward case. □

The following lemma relates collaboration reductions to type reductions when a `roll_error` is produced.

**Lemma A.2.** *Let  $C = (\bar{a}(x).P \mid a(y).Q)$  such that  $C \blacktriangleright \{\bar{a} : T_1, a : T_2\}$  and  $T_1 \dashv\!\!\dashv T_2$ . If  $C \rightsquigarrow^* (\nu s : C)(\langle \tilde{P}_1 \rangle \blacktriangleright P_2 \mid \langle \tilde{Q}_1 \rangle \blacktriangleright Q_2)$  and  $P_2 \xrightarrow{\text{roll}} P'_2$ , then there exist  $U_1, U_2, U'_1, U'_2, U''_1$  such that  $(T_1, T_2) : \langle \tilde{T}_1 \rangle \blacktriangleright T_1 \parallel \langle \tilde{T}_2 \rangle \blacktriangleright T_2 \longmapsto^* (T_1, T_2) : \langle \tilde{U}_1 \rangle \blacktriangleright U'_1 \parallel \langle \tilde{U}_2 \rangle \blacktriangleright U'_2$  and  $U'_1 \xrightarrow{\text{roll}} U''_1$ .*

*Proof.* From  $C \blacktriangleright \{\bar{a} : T_1, a : T_2\}$ , by applying [T-PAR], [T-ACC] and [T-REQ], we have that  $\emptyset; \emptyset \vdash P \blacktriangleright x : T_1$  and  $\emptyset; \emptyset \vdash Q \blacktriangleright x : T_2$ . By applying rule [F-CON] to the collaboration  $C$ , we obtain  $C \rightarrow (\nu s : C)(\langle P[\bar{s}/x] \rangle \blacktriangleright P[\bar{s}/x] \mid \langle Q[s/y] \rangle \blacktriangleright Q[s/y]) = C'$ . Now, by repeatedly applying Lemma A.1, from  $C' \rightsquigarrow^* (\nu s : C)(\langle \tilde{P}_1 \rangle \blacktriangleright P_2 \mid \langle \tilde{Q}_1 \rangle \blacktriangleright Q_2)$  we get  $(T_1, T_2) : \langle \tilde{T}_1 \rangle \blacktriangleright T_1 \parallel \langle \tilde{T}_2 \rangle \blacktriangleright T_2 \longmapsto^* (T_1, T_2) : \langle \tilde{U}_1 \rangle \blacktriangleright U'_1 \parallel \langle \tilde{U}_2 \rangle \blacktriangleright U'_2$  for some  $U_1, U_2, U'_1, U'_2$ , with  $\Theta_2; \Gamma_2 \vdash P_2[x/\bar{s}] \blacktriangleright x : U'_1$ . Now, let us consider the transition  $P_2 \xrightarrow{\text{roll}} P'_2$ . This can be derived only by the application of rules [P-RLL]. Thus,  $P_2 = \text{roll}$ , from which we have  $P_2[x/\bar{s}] = \text{roll}$ . From  $\Theta_2; \Gamma_2 \vdash \text{roll} \blacktriangleright x : U'_1$ , by rule [T-RLL], we get  $U'_1 = \text{roll}$ . Therefore, by rule [TS-RLL<sub>2</sub>], we can conclude  $U'_1 \xrightarrow{\text{roll}} U''_1$  with  $U''_1 = \text{end}$ . □

The following lemma relates collaboration reductions to type reductions when a `com_error` is produced.

**Lemma A.3.** *Let  $C = (\bar{a}(x).P \mid a(y).Q)$  such that  $C \blacktriangleright \{\bar{a} : T_1, a : T_2\}$  and  $T_1 \dashv\!\!\dashv T_2$ . If  $C \rightsquigarrow^* (\nu s : C)(\langle \tilde{P}_1 \rangle \blacktriangleright P_2 \mid \langle \tilde{Q}_1 \rangle \blacktriangleright Q_2)$ ,  $P_2 \xrightarrow{\ell} P'_2$  and  $\neg Q_2 \Downarrow_{\bar{\ell}}$  with  $\ell$  of the form  $k!\langle v \rangle$ ,  $k?(x)$ ,  $k \triangleleft l$  or  $k \triangleright l$ , then there exist  $U_1, U_2, U'_1, U'_2, U''_1$  such that  $(T_1, T_2) : \langle \tilde{T}_1 \rangle \blacktriangleright T_1 \parallel \langle \tilde{T}_2 \rangle \blacktriangleright T_2 \longmapsto^* (T_1, T_2) : \langle \tilde{U}_1 \rangle \blacktriangleright U'_1 \parallel \langle \tilde{U}_2 \rangle \blacktriangleright U'_2$  with  $\tilde{P}_1$  (resp.  $\tilde{Q}_1$ ) in checkpoint accordance with  $\tilde{U}_1$  (resp.  $\tilde{U}_2$ ),  $U'_1 \xrightarrow{\text{tl}_\Gamma(\ell)} U''_1$ , with  $\Gamma$  sorting for typing  $P'_2$ , and for all  $U''_2$  such that  $U'_2 \xrightarrow{\tau} U''_2$  we have  $U''_2 \xrightarrow{\text{tl}_\Gamma(\ell)}$ .*

*Proof.* From  $C \blacktriangleright \{\bar{a} : T_1, a : T_2\}$ , by applying [T-PAR], [T-ACC] and [T-REQ], we have that  $\emptyset; \emptyset \vdash P \blacktriangleright x : T_1$  and  $\emptyset; \emptyset \vdash Q \blacktriangleright x : T_2$ . By applying rule [F-CON] to the collaboration  $C$ , we obtain  $C \rightarrow (\nu s : C)(\langle P[\bar{s}/x] \rangle \blacktriangleright P[\bar{s}/x] \mid \langle Q[s/y] \rangle \blacktriangleright Q[s/y]) = C'$ . Now, by repeatedly applying Lemma A.1, from  $C' \rightsquigarrow^* (\nu s : C)(\langle \tilde{P}_1 \rangle \blacktriangleright P_2 \mid \langle \tilde{Q}_1 \rangle \blacktriangleright Q_2)$  we get  $(T_1, T_2) : \langle \tilde{T}_1 \rangle \blacktriangleright T_1 \parallel \langle \tilde{T}_2 \rangle \blacktriangleright T_2 \longmapsto^* (T_1, T_2) : \langle \tilde{U}_1 \rangle \blacktriangleright U'_1 \parallel \langle \tilde{U}_2 \rangle \blacktriangleright U'_2$  for some  $U_1, U_2, U'_1, U'_2$ , with  $\Theta_2; \Gamma_2 \vdash P_2[x/\bar{s}] \blacktriangleright x : U'_1$  and  $\Theta'_2; \Gamma'_2 \vdash Q_2[y/s] \blacktriangleright y : U'_2$ . Now, let us reason by case analysis on the rule for deriving the transition  $P_2 \xrightarrow{\ell} P'_2$ .

**Rule [P-SND]:** Thus,  $P_2 = \bar{s}!\langle e \rangle.P'_2$  and  $\ell = \bar{s}!\langle v \rangle$  with  $e \downarrow v$ . From  $\Theta_2; \Gamma_2 \vdash P_2[x/\bar{s}] \blacktriangleright x : U'_1$ , by rule [T-SND], we get  $U'_1 = ![S].U''_1$  with  $\Gamma \vdash e \blacktriangleright S$ . Therefore, by rule [TS-SND], we get  $U'_1 \xrightarrow{![S]} U''_1$ .

**Rule [P-RCV]:** Thus,  $P_2 = \bar{s}?(y : S).P'_2$  and  $\ell = \bar{s}?(y)$ . From  $\Theta_2; \Gamma_2 \vdash P_2[x/\bar{s}] \blacktriangleright x : U'_1$ , by rule [T-RCV], we get  $U'_1 = ?[S].U''_1$ . Therefore, by rule [TS-RCV], we get  $U'_1 \xrightarrow{?[S]} U''_1$ .

**Rules [P-SEL] and [P-BRN]:** Similar to the previous cases.

Finally, from  $\neg Q_2 \Downarrow_{\bar{\ell}}$ , following a similarly reasoning, we can conclude  $U'_2 \xrightarrow{\tau} \frac{\tau}{\text{tlr}(\bar{\ell})}$ .  $\square$

The soundness results are as follows.

**Theorem 6.10.** If  $C$  is a roll-safe collaboration, then we have that  $C \not\rightarrow^* \mathbb{C}[\text{roll\_error}]$ .

*Proof.* The proof proceeds by contradiction. Suppose that there exists an initial collaboration  $C$  that is rollback safe and such that  $C \rightarrow^* \mathbb{C}[\text{roll\_error}]$ . The erroneous collaboration `roll_error` can be only produced by applying rule [E-RLL<sub>2</sub>]. Thus, to infer at least one reduction of the sequence  $C \rightarrow^* \mathbb{C}[\text{roll\_error}]$ , rule [E-RLL<sub>2</sub>] must be used. From this, we have that there exists a runtime collaboration  $C' \equiv \mathbb{C}[C'']$ , with  $C'' = (\langle \underline{Q}_1 \rangle \blacktriangleright P_1 \mid \langle \tilde{Q}_2 \rangle \blacktriangleright P_2)$ , such that  $C \rightarrow^* C'$ ,  $P_1 \xrightarrow{\text{roll}} P'_1$ , and  $C' \rightarrow \mathbb{C}'[\text{roll\_error}] \rightarrow^* \mathbb{C}[\text{roll\_error}]$ . By rules [F-CON], [F-RES] and [B-RES], and the fact that the scope of operator  $(\nu s : \_)$  is statically defined (i.e., neither the operational rules nor  $\equiv$  allow scope extension), the term  $C''$  can only be the argument of the operator  $(\nu s : C_1)$ , i.e.  $C' = C_2 \mid (\nu s : C_1)[\_]$ , with  $C_1 = \bar{a}(x).P \mid a(y).Q$  for some  $a, x, y, P$  and  $Q$ . In its own turn, the term  $(\nu s : C_1)C''$  can only be generated by applying rule [F-CON] from  $C_1$ , which must be a subterm of  $C$ , i.e.  $C \equiv C_1 \mid C'_2$  for some  $C'_2$ . Since the scope of  $(\nu s : \_)$  operator cannot be extended, all reductions performed by terms in parallel with it by applying rules [F-PAR] and [B-PAR] do not affect the argument of such operator. Therefore, focussing on the subterm  $C_1$  of  $C$ , by exploiting rules [F-PAR] and [B-PAR] we can set apart the reductions in  $C \rightarrow^* \mathbb{C}[\text{roll\_error}]$  involving  $C_1$  and its derivatives, thus obtaining  $C_1 \rightarrow^* (\nu s : C_1)C'' \rightarrow (\nu s : C_1)\text{roll\_error}$ .

Now, since  $C$  is rollback safe, by Def. 4.3 we have that  $C \blacktriangleright A$  and for all pairs  $\bar{b} : V_1$  and  $b : V_2$  in  $A$  we have  $V_1 \dashv\vdash V_2$ . Since  $C \equiv C_1 \mid C'_2$ , by rule [T-PAR] we obtain  $C_1 \blacktriangleright A_1$  with  $A_1 \subseteq A$ . By rules [T-REQ] and [T-ACC], we have  $A_1 = \{\bar{a} : T_1, a : T_2\}$ . Since  $A_1$  is a subset of  $A$ , we have that  $T_1 \dashv\vdash T_2$ .

By Lemma A.2, we have that there exist  $U_1, U_2, U'_1, U'_2, U''_1$  such that  $(T_1, T_2) : \langle T_1 \rangle \blacktriangleright T_1 \parallel \langle T_2 \rangle \blacktriangleright T_2 \xrightarrow{*} (T_1, T_2) : \langle \underline{U}_1 \rangle \blacktriangleright U'_1 \parallel \langle \tilde{U}_2 \rangle \blacktriangleright U'_2 = t$  and  $U'_1 \xrightarrow{\text{roll}} U''_1$ . Since  $U'_1$  can only perform *roll*, the only rules that can be applied are [TS-RLL<sub>1</sub>] and [TS-RLL<sub>2</sub>]. However, rule [TS-RLL<sub>1</sub>] cannot be applied due to the imposed checkpoint  $\underline{U}_1$ . Therefore, the only rule that can be applied is [TS-RLL<sub>2</sub>], leading to the configuration  $t' = (T_1, T_2) : \langle \underline{U}_1 \rangle \blacktriangleright U''_1 \parallel \langle \tilde{U}_2 \rangle \blacktriangleright U''_2$  with  $U''_1 = U''_2 = \text{err}$ . Now, no rule in Fig. 11 allows the term  $t'$  to evolve, i.e.  $t' \not\rightarrow$ . Since  $T_1 \dashv\vdash T_2$ , by Def. 4.1 it must hold that  $U''_1 = U''_2 = \text{end}$ . However,  $U''_1 = \text{err} \neq \text{end}$  and  $U''_2 = \text{err} \neq \text{end}$ , which is a contradiction.  $\square$

**Theorem 6.11.** If  $C$  is a roll-safe collaboration, then we have that  $C \not\rightarrow^* \mathbb{C}[\text{com\_error}]$ .

*Proof.* The proof proceeds by contradiction. Suppose that there exists an initial collaboration  $C$  that is rollback safe and such that  $C \rightarrow^* \mathbb{C}[\text{com\_error}]$ . The erroneous collaboration `com_error` can be produced by applying one of the rules [E-COM1], [E-COM2], [E-LAB1] and [E-LAB2]. Let us consider the case [E-COM1], the other cases are similar. Proceeding as in the proof of Theorem 6.10, without loss of generality we can focus on the subterm  $C_1 = (\bar{a}(x).P \mid a(y).Q)$  of  $C$ , such that  $C_1 \rightarrow^* (\nu s : C_1)C'' \rightarrow (\nu s : C_1)\text{com\_error}$ , with  $C'' = (\langle \tilde{Q}_1 \rangle \blacktriangleright P_1 \mid \langle \tilde{Q}_2 \rangle \blacktriangleright P_2)$ , and  $C_1 \blacktriangleright \{\bar{a} : T_1, a : T_2\}$ , with  $T_1 \dashv\vdash T_2$ .

By Lemma A.3, we have that there exist  $U_1, U_2, U'_1, U'_2, U''_1$  such that  $(T_1, T_2) : \langle T_1 \rangle \blacktriangleright T_1 \parallel \langle T_2 \rangle \blacktriangleright T_2 \mapsto^* (T_1, T_2) : \langle \tilde{U}_1 \rangle \blacktriangleright U'_1 \parallel \langle \tilde{U}_2 \rangle \blacktriangleright U'_2 = t$  with  $\tilde{Q}_1$  (resp.  $\tilde{Q}_2$ ) in checkpoint accordance with  $\tilde{U}_1$  (resp.  $\tilde{U}_2$ ),  $U'_1 \xrightarrow{![S]} U''_1$ , and for all  $U''_2$  such that  $U'_2 \xrightarrow{\tau}^* U''_2$  we have  $U''_2 \xrightarrow{?[S]}$ . Thus, for all  $U''_2$  as above, we have  $t \mapsto^* (T_1, T_2) : \langle \tilde{U}_1 \rangle \blacktriangleright U'_1 \parallel \langle \tilde{U}_2 \rangle \blacktriangleright U''_2 = t'$ . No rule in Fig. 11 allows the term  $t'$  to evolve, i.e.  $t' \not\mapsto$ , because  $U'_1$  can only perform  $![S]$  and rule [TS-COM] cannot be applied since  $U''_2 \xrightarrow{?[S]}$ . Since  $T_1 \dashv\vdash T_2$ , by Def. 4.1 it must hold that  $U'_1 = \text{end}$ . However, since  $U'_1$  is able to perform an action (as it holds that  $U'_1 \xrightarrow{![S]} U''_1$ ), we get that it cannot be an end type, i.e.  $U'_1 \neq \text{end}$ , which is a contradiction.  $\square$