

# Managing Large Enclaves in a Data Center

Sandeep Kumar

School of Information Technology  
IIT Delhi  
New Delhi, India  
sandeep.kumar@cse.iitd.ac.in

Abhisek Panda

Department of Computer Science and  
Engineering, IIT Delhi  
New Delhi, India  
abhisek.panda@cse.iitd.ac.in

Smruti R. Sarangi

Department of Computer Science and  
Engineering, IIT Delhi  
New Delhi, India  
srsarangi@cse.iitd.ac.in

## Abstract

Trusted execution environments, or TEEs, provide hardware-guaranteed security to an application executing on remote, untrusted clouds, even from the operating system or hypervisor. Migration of applications in data centers is an old and quintessential problem – with standard solutions. However, migrating a TEE-based workload is still done using the decade-old stop-and-copy-based method, where the entire application’s execution is stopped, and the state is collected and transferred.

We show this approach has a large downtime for secure applications with large memory footprints using Intel SGX, a TEE solution from Intel. We also highlight the challenges in adopting the existing, well-established migration solutions for SGX-based applications because of the security limitations TEE imposes. Essentially, implementing a traditional migration scheme for SGX-based requires giving untrusted entities access to the secure portion of the application – a complete breakdown of TEE’s security guarantees. We propose a new technique, ConstMig, to circumvent these limitations and implement secure enclave live migration with a near-zero downtime while maintaining the security guarantees of SGX. We propose two novel ways to implement live migration: first, implementation is based on page table bits, and second, based on a compiler pass. Our optimizations reduce the total downtime by 77-96% for a suite of SGX applications with multi-GB memory footprints. We show results for our system on a real cloud and in settings that use containers, VMs, and microVMs.

## 1 Introduction

Cloud services are widely utilized for hosting web applications, training ML/AI workloads, data analytics, and a multitude of other purposes. These applications many times handle sensitive data, such as from that medical and finance domain [29, 78, 87]. Hence, in the past few years, data and applications’ security has become a prime design criterion. Recognizing this requirement, leading cloud service providers like Microsoft and Google offer hardware-assisted *trusted execution environments*, or TEEs, such as Intel SGX [60], Intel TDX [38], AMD SEV [64], ARM Trustzone [24], and RISC-V Keystone [69]. In a TEE, the hardware ensures the application’s security and the execution is free of snooping, even from privileged entities, such as the operating system, the hypervisor, and the cloud administrator.

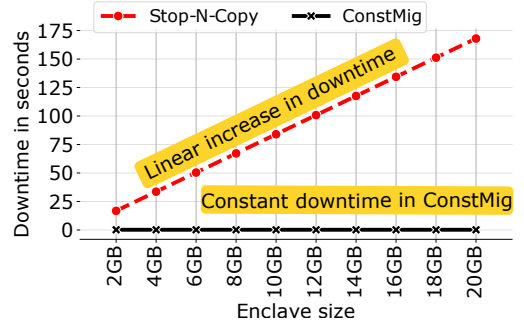

**Figure 1.** ConstMig ensures a constant total downtime while migrating an SGX-based application, irrespective of its size

TEE-based secure applications are extensively used in domains such as databases, networking, peer-to-peer systems, cloud services, data analytics, and training AI/ML models. They are particularly suited for processing sensitive data, such as healthcare records and customer feedback, which often span multiple gigabytes and demand significant secure memory resources [27, 30, 48, 79, 99]. Recently, TEEs are also being adopted to securely train AI/ML models where it is critical to protect either the data or the generated model or both [8, 44, 54, 85, 94].

However, the use of TEE solutions creates a challenge for data center management. In a data center, migration of an application or a virtual machine from one machine to another is arguably one of the most common and important operations in modern data centers [28, 31, 47, 63, 65, 72, 90, 95, 97, 102]. Cloud service providers rely on efficient *migration* to provide high availability, load balancing, efficient resource management, and failure tolerance. Moreover, migration is crucial when vulnerabilities in the hypervisor, kernel, or VM manager introduce security risks, such as zero-day exploits that threaten the entire system.

Traditional migration schemes, in a non-TEE setting, utilize efficient page access tracking mechanisms provided by modern hardware and operating systems to achieve a near-zero downtime during migration [40, 52]. This is also known as *live migration*, and there are two primary ways to achieve this – pre-copy [40] and post-copy [52] migration methods. In the former, the application’s state is transferred in the background while it is still running on the source machine. Once the transfer is complete, pages modified are transferred

again (expected to be far fewer than the overall memory footprint). The migration method leverages the *dirty bits* in the page table entries, which are automatically set by the hardware upon a write operation, to track the modified pages [4]. In the latter approach, a minimal amount of additional state along with the application is migrated to the destination machine and resumed there. The rest of the state is pulled in the background (known as post-copy [52]). Here, the migration method uses *userfaultfd*, a mechanism that allows page faults to be handled in the user space, to prevent the restored application from accessing a page that has not been transferred yet.

However, our experiments show that on the latest version of Intel Xeon processors, both of the requirements – dirty page tracking and user space fault handling – do not work (§ 3.4). As a result, traditional migration operations cannot be directly applied to TEEs. Hence, Intel TDX and AMD SEV, two new TEE solutions from Intel and AMD, have hardware support to enable live migration [25, 98] – a feature missing from Intel SGX [75]. There are some fundamental differences between TDX and SGX. TDX provides confidential virtual machines (CVM) [71] to securely execute applications. SGX, on the other hand, provides secure enclaves where a portion of an application (typically a sensitive portion) executes and the rest executes in the traditional manner. Due to this difference in programming and execution model, SGX provides much more flexibility in terms of execution, which can lower the overhead performance. Furthermore, the trusted computing base, or TCB, of Intel SGX is much smaller compared to that of Intel TDX, which is a crucial requirement to strengthen the security of sensitive applications (more details in Section 3.5). Prior work in enabling migration for SGX relied on the classical stop-and-copy method for migrating the SGX enclave state [23, 50, 70, 75, 88] from one machine to another. Here, an executing application is stopped, a checkpoint is taken, and the checkpoint is transferred to the destination machine. This approach has a large downtime, which grows as the memory footprint of the secure application increases (see Figure 1).

In this paper, we propose a new live migration scheme *ConstMig* for Intel SGX, which uses a novel strategy to transfer both secure and unsecure pages – it has a near-zero downtime and far lower performance overheads than the state-of-the-art (see Figure 1.) Our migration method follows a hybrid approach: at the beginning of migration, we initially use the pre-copy method to send a small part of the application’s runtime state to the destination machine. Second, the information about the active memory regions is used on the destination machine to enable an on-demand (post-copy) migration of the complete state of the application. A post-copy approach requires fine-grained tracking of memory accesses on the destination machine to ensure that the restored application reads valid data from the source machine (instead of an invalid, all-zero page). We propose two

access tracking mechanisms: ❶ based on fine-grained page fault tracking and ❷ based on fine-grained pointer access tracking. In addition to adhering to all the security guarantees of SGX, ConstMig also adds a freshness guarantee to the migration process, which ensures that an attacker cannot replay old encrypted enclave data during migration. Our approach has been tested on real cloud settings and even works with containers, VMs, and microVM-based settings.

**Contributions:** Our key contributions are as follows:

1. We thoroughly characterize SGX and identify the key challenges faced while adopting modern migration schemes for enclaves (with minimal downtime).
2. We propose a novel migration scheme that addresses these challenges and enables near-constant downtime while migrating large-sized SGX applications. To our knowledge, **we are the first to implement this and show its benefits.**
3. We propose novel optimizations during the migration process that reduce the total migration time and reduce the cost of migration.
4. We evaluate our solution using a set of widely used SGX benchmarks. Our scheme outperforms the current state-of-the-art [75] by 77-96% for a suite of Intel SGX applications that have multi-GB memory footprints.

The rest of the paper is organized as follows. We present the necessary background for the paper in Section 2, motivate the work in Section 3, and present the design in Section 4. We discuss our novel access tracking mechanism in Section 5. We present a security analysis in Section 6. We show the evaluation results in Section 7. A brief discussion of related work follows in Section 8, and we finally conclude in Section 9.

## 2 Background

### 2.1 Migration Methods

The performance of a migration operation is measured using two metrics: *total downtime (DT)* – total time the application is not running, and *total migration time (MT)* – total time elapsed from the start of the migration to its finish [75, 91]. Apart from these, we also evaluate the overhead of ConstMig on an application’s performance when *not* migrating.

**Stop-and-Copy Migration** In a stop-and-copy migration approach [40], the application being migrated is frozen or “paused” at the beginning of the migration and is kept paused during the state transfer from the source machine to the destination machine. It is resumed only after the transfer is complete. Here, the total migration time and total downtime are proportional to the size of the heap, as in modern applications, the size of the “total state” is dominated by the size of the heap [21].

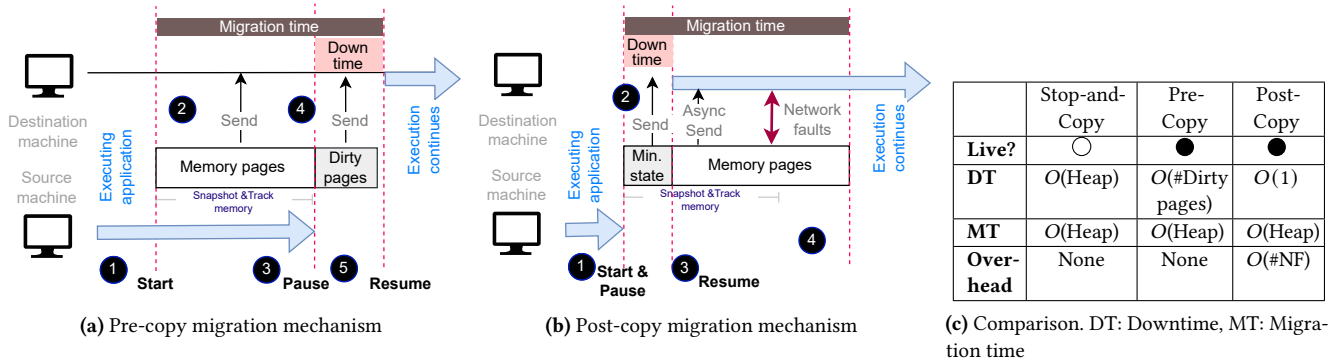

**Figure 2.** Working of the pre-copy and post-copy migration mechanisms. The total downtime is independent of the memory footprint. **Start** indicates the start of migration, **Pause** and **Resume** indicate pausing and resuming the application, resp.

**Pre-copy Migration:** In a pre-copy migration scheme, ❶ the first step is to save the state of an application and start *tracking* the application’s memory for any write operation. ❷ Second, transfer the complete state to the destination machine. ❸ Calculate modified data in terms of 4KB pages – *dirty pages*. If the number of dirty pages is less than a threshold, the application is paused, ❹ the dirty pages are transferred to the destination machine, and ❺ the application is resumed on the destination machine (see Figure 2a). However, if the number of dirty pages exceeds a threshold, only the dirty pages are saved and transferred, and the process resumes from step 3. Here, the total migration time is proportional to the heap size, and the total downtime is proportional to the number of dirty pages in the final tranche of pages that are sent.

**Post-Copy Migration:** Here, ❶ an application is paused on the source machine, a minimal amount of the state (CPU state, registers, and non-pageable memory [40, 52]) is sent to the destination machine, ❷ and the application is resumed on the destination machine. Once the application has resumed, ❸ a background thread starts the transfer of its memory state from the source to the destination machine. During the state transfer, the migration method tracks the memory usage of the application on the destination machine. ❹ Any request to use the data that is still on the source machine results in a *network page fault* and is transparently handled by the migration mechanism and OS (see Figure 2b). Here, the total migration time is proportional to the heap size, but the total downtime is constant. However, the application might slow down during the migration due to expensive network faults. Figure 2c shows a brief overview of the migration methods.

## 2.2 Intel Software Guard eXtensions

Intel Software Guard eXtension, or SGX, provides a secure way to execute an application on a remote, untrusted machine by creating a secure sandbox called an *enclave*. At boot time, SGX reserves a part of the main memory for its

operation called the *processor reserved memory* (PRM). The PRM is managed by the hardware and is encrypted using a hardware key that is not accessible to any entity, including the OS, hypervisor, SGX driver, and the SGX application. The PRM is divided into two parts: the *enclave page cache* (EPC) and the *metadata region*. The EPC is used to allocate pages to the enclave. The metadata region is used to store the metadata of the enclaves. The enclave is executed as a part of an application that also has an unsecure component. The unsecure component can call a function inside an enclave using a mechanism called an *enclave call* or ECALL. Similarly, an enclave can also call functions in the unsecure components using a mechanism called *outside call*, or OCALL [43].

**Scalable SGX** In the previous generation of SGX, referred to as SGXv1 in this paper, the size of the usable EPC was limited to 92 MB [58, 66, 68], which limited the use case of SGX for large memory footprint workloads. To mitigate the issue of the limited size of the EPC, Intel has announced a new generation of SGX, called scalable SGX, which can support an EPC up to 512 GB [11, 15].

SGX guarantees that the enclave being executed has not been tampered with. In order to do so, in SGXv1, before executing the enclave, SGX loads the entire memory of the enclave in the EPC and calculates the signature of the loaded enclave (including any statically defined fields). The signature verification serves as an integrity check. Although secure, the initialization time of a large memory footprint enclave can be quite large as it requires all the pages to be added to the enclave upfront. As per our measurements, initializing an enclave of 20 GB takes around  $\approx 30$  seconds. In order to solve the issue, Intel introduced (*Enclave Dynamic Memory Management* or EDMM in SGX [53]). EDMM allows the user to configure what amount of memory that must be added during the enclave’s initialization, hereby referred to as *committed pages*, and the amount of memory that can be added later. We refer to the latter as *uncommitted pages*.

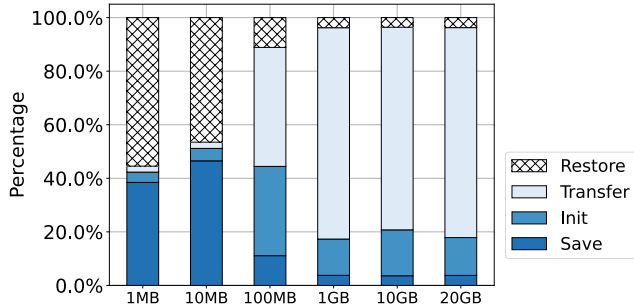

**Figure 3.** For large enclaves, the total migration time is dominated by the enclave initialization time on the destination machine and the total transfer time.

In principle, this allows an enclave with a 512GB memory requirement to start with a single committed 4K page.

### 3 Motivation and Characterization

In this section, we discuss the motivation for the paper.

#### 3.1 Microbenchmark

For the experiments in this section, we use a microbenchmark that performs a fixed number of ECALLs to an enclave. For each ECALL, it allocates a temporary buffer on the heap, performs sequential write and then read operations on the buffer, and then frees it. We measure the time to finish a fixed number of ECALL operations. The configuration of the systems used for experiments in this section is listed in Section 7.

#### 3.2 Breakdown of the Total Downtime

As seen in Section 2, the design used by prior work to migrate an SGX enclave is based on *stop and copy* [40] migration method. This mechanism has a scaling issue. In our experiments, we observed that the total time to migrate an enclave of size (mostly heap size) 1GB is  $\approx 8$  seconds, which increases to  $\approx 160$  seconds when the enclave size is 20 GB, an increase of 20 $\times$ . This is because in stop-and-copy the downtime is proportional to the size of the enclave. This is a significant issue as the size of the enclave is bound to increase in the future with the advent of new processors with larger EPC memory. The current generation of Intel SGX already has an EPC of 512 GB.

The total migration time of an enclave can be broken down into four phases: save, transfer, initialize, and restore. As shown in Figure 3, for small enclave sizes ( $\approx 10$  MB), the total migration time is dominated by the save and restore phases. However, for larger enclave sizes ( $>100$  MB), the network transfer phase dominates the total migration time (up to 96% for 10 GB+ enclaves).

**Insight:** *There is a requirement for efficient migration schemes where the total downtime is independent of the enclave size.*

#### 3.3 Enclave Initialization & Down Time

As seen in Figure 3, after network transfer time, the time to initialize an enclave affects the migration time the most (17%). This is because the initialization time of an enclave is proportional to the number of committed pages (§2).

In SGX, the pages can be added in a deferred state or “pending” state [53] and, when required, can be added to the enclave later on. This significantly improves the initialization time of the enclave. An enclave with 1 MB of committed memory can start in less than 1 ms, whereas with 1 GB of committed memory, the enclave takes  $\approx 2$  seconds to start. However, doing so negatively affects the application’s performance in the enclave. A `free()` operation on the committed pages just marks the page free [53]. However, a `free()` operation on uncommitted pages returns the pages to the EPC pool. They must be added back to the enclave using EAUG and EACCEPT instructions.

**Insight:** An SGX workload with frequent memory allocations and deallocations should be initialized with more committed memory pages to reduce the overhead from EREMOVE and EAUG instructions. Conversely, workloads with fewer allocations can start with fewer committed pages. *This insight helps minimize enclave initialization time, contributing to reduced overall downtime (see §7).*

#### 3.4 Challenges in Adopting Live Migration for SGX

**3.4.1 Challenges in Pre-Copy Migration:** As discussed before (§2.1), tracking an application’s address space for dirty pages is a key requirement for a pre-copy migration method. Current migration methods use the SOFT\_DIRTY [4] or *dirty* bit of the page table entry of every 4 KB data page to track dirty pages [16, 17]. In order to do so, the first step is to clear the dirty bit of all the pages by writing 4 to `/proc/<pid>/clear_refs` of the process. After this, any write operation to data pages will set the dirty bits in the corresponding page table entries pages, which can be read from `/proc/<pid>/pagemap`.

**Challenges with dirty bits in SGX:** Prior work [34, 35] reported that the dirty bits are set even for SGX-backed pages and can be used to track write operations inside an enclave without causing page faults, as clearing *dirty bits* does not cause a page fault. However, their experiments were conducted on the Intel Skylake i7-6700 processor [55], a desktop-class CPU released nine years ago. Since then, Intel has phased out SGX support on desktop CPUs, limiting SGX functionality to server-class processors [93]. Also, Intel has incorporated multiple mitigation techniques to thwart attacks against Intel SGX [45, 57, 81].

Although none of the countermeasures explicitly mention that the dirty bits will not be set for SGX-backed address spaces, we have observed in our experiments with Xeon-6354 [3], a server-class CPU that was launched in 2021, that dirty bits are **not** set for SGX-backed addresses even after

multiple write operations. *We have also written to Intel to confirm this. We are yet to receive a reply on this.* To test and validate this claim, we have provided the steps to run our micro-benchmark along with an anonymized link to the source code in Appendix A. Hence, the standard page table-based access tracking method will not work for an SGX application, preventing a pre-copy migration.

**3.4.2 Challenges in Post-Copy Migration.** As discussed before (§2.1), tracking the memory accesses of a restored application is a key requirement for a post-copy method. The migration manager relies on capturing the application page faults to track these accesses. If the application tries to access a missing page on the destination machine, it will trigger a page fault. The OS provides a way to handle these faults in user space via a mechanism called *userfaultfd* [14]. Here, the faults are delivered to the migration manager, which fetches the data from the source machine and serves the fault. This is called a network page fault and is an expensive operation.

As of now, the *userfaultfd* mechanism only supports anonymous pages, huge pages, or shared memory [13]. However, the secure memory of SGX enclaves is mapped onto the device `/dev/i sgx`. The *userfaultfd* mechanism, at the moment, does not support such device-backed memory regions [10, 12, 13, 42]. Hence, a post-copy migration based on *userfaultfd* will not work for SGX enclaves.

### 3.5 Intel SGX vs Intel TDX

Intel TDX introduces the concept of hardware-protected confidential virtual machines (CVMs) [71] or a trusted domain (or TD) as referred to in Intel’s documentation. A CVM allows users to execute unmodified applications with the protection of the TEE environment. However, the guest kernel must be modified as per TDX guidelines [39]. Here, all the data and code of the application are encrypted and beyond the reach of the host operating system or the hypervisor. Intel TDX allows for the live migration of a CVM with hardware support. However, there are some drawbacks in terms of performance and the size of the trusted computing base (TCB) [71].

**3.5.1 Size of the Trusted Computing Base (TCB).** Intel TDX has a significantly larger TCB compared as it secures the entire CVM. The TCB includes the TDX-enabled processor with Virtualization Technology (VT), Multi-key Total Memory Encryption (MKTME), and SGX [39]. TDX relies on SGX for remote attestation [39]. The TCB also contains the TDX Module, which contains 20,000 lines of code [61], and the entire guest operating system with any other software stacks running within the CVM [39].

Such a large TCB provides a wide attack surface and makes Intel TDX inherently susceptible to errors and vulnerabilities. The complexity of the TDX Module and its interactions with the hardware and guest OS increases the likelihood of

Entity	Trusted?	Access
Operating system	✗	Page fault sequence
Migration manager (CRIU)	✗	Page fault sequence
Trusted Library (ConstMigLib)	✓	Everything

**Table 1.** Entities involved in migration and their trust level

errors and vulnerabilities. 54% of the identified vulnerabilities related to Intel TDX are associated with the underlying firmware [71].

SGX’s TCB primarily encompasses the processor, the microcode and the firmware supporting security guarantees, the SGX driver and libraries, and the secure portion of an application code. The untrusted code of the application and the host operating system are *not* part of the TCB.

**3.5.2 Performance overhead comparison.** In a TEE solution, frequent transitions between secure and insecure worlds and memory encryption are the main causes of performance overheads. Intel SGX provides execution flexibility by partitioning an application into trusted and untrusted regions. The trusted part executes in a secure enclave within SGX. The untrusted part executes in a traditional manner with no performance loss. The performance overhead is observed only when the execution occurs inside SGX.

However, applications executing in a CVM pay the full cost of performance overhead due to complete memory encryption and VM exits [71]. As per [41], PyTorch inference executed on SGX with the LibOS Gramine [36] demonstrates improvements in performance by up to 78.6% compared to Intel TDX and 32.25% compared to AMD SEV-SNP. Furthermore, [67] illustrates that programs executing natively on SGX, after the partition of secure and insecure code, outperform the performance of those using LibOS Gramine by up to 3%.

**Overhead due to memory encryption:** Applications executing inside a CVM must encrypt all their data, regardless of whether it is sensitive or not, resulting in performance overhead [56]. Applications executing outside of a CVM can bypass the memory encryption using the "TME-Bypass" mode.

**Overhead due to VM Exits:** [71] show that workloads that require frequent VM exits can suffer performance slowdowns of up to 240% and 472% on AMD SEV and Intel TDX, respectively, compared to traditional VMs. The additional overhead in TDX is mainly due to the involvement of the TDX module in handling VM exits, which adds extra processing steps [71].

## 4 Design

In this section, we discuss the design of ConstMig. The primary design goals of ConstMig are as follows:

1. Enable live migration for large SGX enclaves with minimal total downtime
2. Minimize performance degradation (reciprocal of execution time) due to migration
3. Maintain confidentiality, freshness, and integrity of the data at all points of time, including the migration process.

We primarily focus on the heap memory, as it dominates the overall memory footprint of an application [21]. The size of the other segments, such as *data* and *BSS*, range from a few KBs to MBs. They are *always* sent synchronously (as a part of the minimal state transfer process) during migration. Furthermore, we do not discuss migration of *sealed data*. SGX provides a way to seal data using a hardware-bound key. Alder et al. [23] proposed a method to migrate sealed data by encrypting all the sealed data with a software-generated key on the source machine and resealing it on the destination machine after transfer and decryption. This solution can be easily incorporated into ConstMig.

#### 4.1 Threat Model

We make the same security assumptions as Intel SGX and prior work in this area (see Table 1). The operating system and the unsecure migration manager (CRIU) are *not* trusted. They never see the enclave’s data in plaintext, or have access to the keys used during migration.

For SGX, the OS handles the page table of a secure application. A malicious OS can manipulate the PRESENT bit in the page table entries (PTEs) to capture the complete page-access pattern of an application [100]. Additionally, it has been shown that SGX is vulnerable to Prime+Probe attacks [84], and speculative execution-based side-channel attacks [37]. Such attacks are not in the purview of SGX, and are out of the scope of this work (see §6). The community has proposed defense mechanisms against such attacks in SGX (see [33]). Any of them can be used to protect against such attacks. They are complementary schemes.

We maintain the following invariants during the migration operation:

1. **Invariant 1:** It is never possible that a page fault with virtual address  $V$  on the destination machine is served with the data of a page with virtual address  $V'$ .
2. **Invariant 2:** We only consider the heap’s data pages; the rest of the pages are sent a priori.
3. **Invariant 3:** Once the migration key is transferred, the source *cannot* be resumed.
4. **Invariant 4:** A single page is “saved” and “restored”, at most once.
5. **Invariant 5:** The migration key ( $M_k$ ) is a function of the PUF of the source machine, boot time, current time, and the output of a TRNG. A replay attack is thus not possible (§ 6).

If any security violation is detected at any point in time during migration, we abort the migration, and both instances of the enclave (original and restored) are lost.

#### 4.2 Overview

There are two main components in ConstMig: the *migration manager* that orchestrates the whole migration process and a trusted SGX library (*ConstMigLib*), which is linked to the secure application. Its routines have access to the secure memory space of the application running in the enclave.

**4.2.1 Migration Manager.** We use the widely popular *Checkpoint/Restore In Userspace* or CRIU [2, 75, 91, 96] package as our migration manager. CRIU is *not* a part of the trusted codebase and never sees the migrating enclave data in plaintext. CRIU supports both pre-copy and post-copy live migration methods. However, it does not support the migration of a complete SGX application. An application running on SGX has two components: an unsecure component that executes outside SGX and a secure component that executes within an enclave. CRIU can handle the migration of the unsecure component. We modify CRIU to handle the SGX enclave migration as follows.

1. **Communication between CRIU and the enclave:** A save signal to an enclave triggers a state save process at the beginning of the migration. A restore signal triggers restoration when resumed on the destination machine. The signals are captured and processed by ConstMigLib.
2. **Encrypted buffers:** We use two data buffers: a backup buffer (BBuff) and a metadata buffer (MBuffer) allocated in the untrusted memory region (outside the SGX enclave). The enclave uses BBuffer to save its heap content and MBuffer to store metadata after encryption. We also use MBuffer buffer to store the BSS and data segments.
3. **Buffer transfer:** We employ different transfer techniques to send the two buffers.
  - a. **MBuffer** Due to its relatively small size, MBuffer is transferred using the pre-copy approach and sent synchronously to the destination at the beginning of the migration. Its contents are immediately restored after a fresh enclave is initialized on the destination machine.
  - b. **BBuffer** We use the post-copy approach to transfer the larger BBuffer. CRIU enables the *userfaultfd* mechanism for BBuffer. A read operation on this buffer on the destination machine will always read the data as it is on the source machine – either the data has already been transferred, or it is pulled synchronously via a network page fault [52].
4. **A consistency checker:** CRIU handles the restoration of BBuffer on the destination machine. However, CRIU is not SGX migration aware. We need to ensure that BBuffer

is transferred only after the enclave state has been successfully saved on it. Furthermore, we must ensure that the restored enclave only reads restored data. Our consistency checker ensures this by maintaining three bit-vectors: `save_vec`, `internal save_vec`, and `restore_vec` of size equal to the number of 4KB pages in `BBuff`. These vectors indicate when a page is ready to be transferred and when a page has been restored successfully. `save_vec` is maintained in the untrusted region as it is required by CRIU, and `internal save_vec` is stored in the trusted region of the source machine to track the pages that are saved securely. Both are updated by `save_th`.

### 4.3 ConstMig library (ConstMigLib)

We statically link each SGX application with a trusted library (ConstMigLib). The library implements three main components:

1. **Memory manager:** We implement a memory manager (OptMgr) to handle memory (de)allocation requests within an enclave. Specifically, We create overloaded implementations of `malloc()` and `free()` to handle all the allocation and free requests. For every allocation request, we store the address of the allocated region, its size, and a unique id in an array-like structure (MemArr). A free call updates the MemArr by deleting any freed region. During migration, MemArr is encrypted and stored in `MBuff` and sent synchronously along with the data and bss segments of the enclave to the destination machine.
2. **Save thread:** A save thread (`save_th`) handles the save command initiated by CRIU and starts saving the heap content on `BBuff`. The thread operates at a granularity of 4KB pages. Upon saving a page, it sets the corresponding bit in `save_vec` to indicate that the particular page in `BBuff` is ready to be transferred to the destination machine.
3. **Restoring thread:** A restore thread (`restore_th`) handles the restore command initiated by CRIU and starts restoring the heap contents from `BBuff`. It also operates at the granularity of 4KB pages. Upon restoring a particular page, it sets the corresponding bit in the `restore_vec` to indicate that it has been restored.

### 4.4 High-level Operation

**Start migration:** As shown in Figure 4, at the beginning of the migration, ❶ CRIU pauses the application and sends the save signal to ConstMigLib. We modified CRIU to resume a single thread for ConstMigLib to work. ❷ ConstMigLib generates a master key  $M_k$  that is used to encrypt data before saving in the untrusted region. ConstMigLib then saves the data segment, BSS segment, and OptMgr metadata (information about the allocated regions) in `MBuff`. ❸ `save_th` starts saving heap data on `BBuff`.

**Handshake:** ❹ CRIU sends a signal to spawn a fresh enclave on the destination machine after the start of the migration operation. Once the enclave is initialized, ConstMig first performs a remote attestation [26] to verify that only a valid enclave with a ConstMigLib is running on the machine, thereby establishing the “chain of trust” on the destination machine. Once the enclave is validated, ConstMig transfers  $M_k$  to the destination machine using a secure key transfer protocol that ensures that the key is only transferred to the intended destination machine [26]. The original enclave cannot be resumed after this (see Invariant 3). ❺ Following this, the destination machine receives a minimal version of the application’s state and the contents of `MBuff`, which are encrypted using  $M_k$ , from the source machine.

**Start Restore:** ❻ The trusted library on the destination machine reads the encrypted bss segment, data segment, and memory manager’s metadata from `MBuff`, and restores it using  $M_k$ . CRIU on the source machine starts sending `BBuff` to the destination machine. ❼ CRIU on the destination machine sends the restore signal to ConstMigLib. ❽ `restore_th` starts reading data from `BBuff` and starts restoring. Since `BBuff` is protected by `userfaultfd`, `restore_th` is guaranteed to read valid pages. We modify CRIU to send a page only if the corresponding bit in the `save_vec` is set – indicating that `save_th` has saved the data in the page.

**Cleanup:** Once the restoration is done (indicated by `save_vec` and `restore_vec`), ConstMigLib zeros all the allocated pages on the source machine and kills the application. At any given time, *an application runs on only one system*.

---

#### Algorithm 1 Prepare Encrypt Packet

---

```

1: procedure PREPAREENCRYPTPACKET( $P, VAp, M_k$ )
2:   Check(internal save_vec)
3:    $H \leftarrow \text{Hash}(PC(P) \parallel VAp)$       ▶ Link the page content with its
      address
4:    $C \leftarrow \text{Encrypt}(PC(P) \parallel H, M_k)$ 
5:   Update (save_vec, internal save_vec)
6:   return  $C$ 
7: end procedure

```

---

### 4.5 Save and Restore details

**4.5.1 Saving Data.** ConstMigLib employs a post-copy-based technique to transfer heap data between the source and destination machines. On the source machine, as shown in Figure 5a, ConstMigLib stores heap data using `save_th` that maintains three data structures: `BBuff`, `save_vec`, and `internal save_vec`. `BBuff` contains the contents of each page along with a hash value. `save_vec` and `internal save_vec` are two bit vectors that indicate the presence of a page in `BBuff`. Note that `save_vec` is stored in the unsecured memory as it is required by CRIU while serving a network page fault. `Internal save_vec` is stored in the trusted memory region, and is used to track the pages that have been saved to

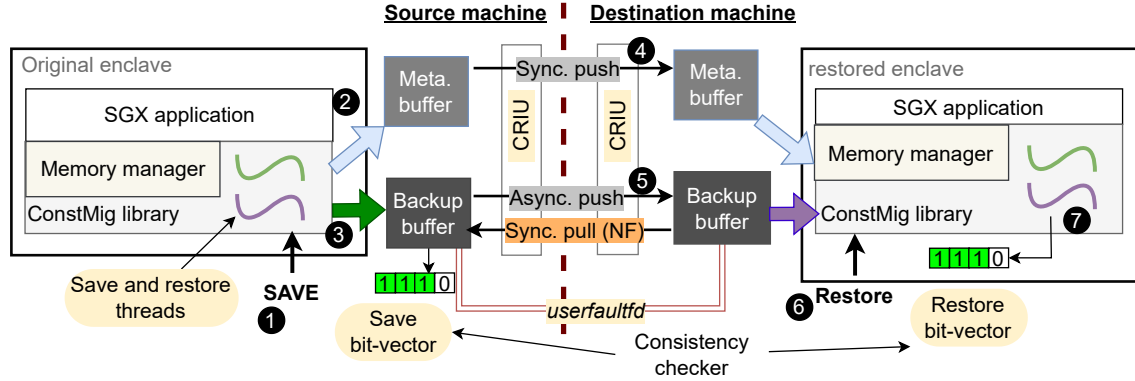
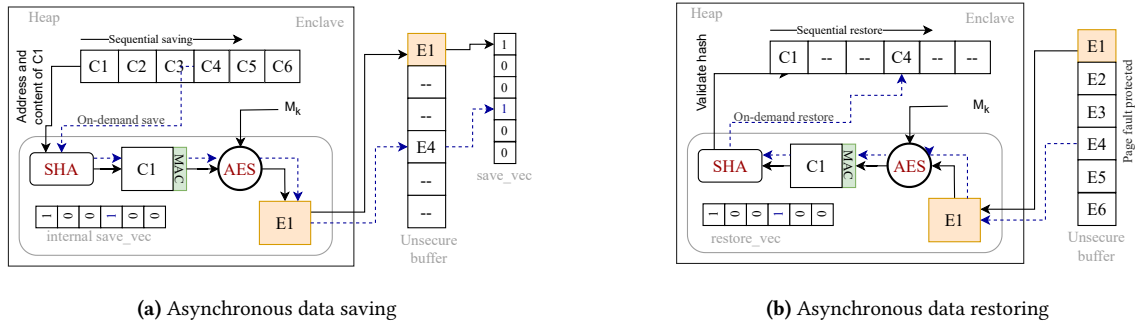

Figure 4. A high-level overview of the working of ConstMig.



(a) Asynchronous data saving

(b) Asynchronous data restoring

Figure 5. Key components involved in saving the pages on the source machine and restoring them on the destination machine. Note that `save_vec` is allocated in the untrusted memory region so that CRIU can read it while servicing a network fault. However, `restore_vec` is allocated inside an enclave as there is no need on the destination machine for CRIU to read it.

BBuffer. All entries in `save_vec` and `internal save_vec` are initially set to zero.

Right before encrypting a packet, the corresponding bit in the `internal save_vec` is checked. If the bit is already set, it indicates that the page has already been restored. This is a security violation, and the migration has to be aborted. If the bit was not set, then we proceed further. As shown in Algorithm 1, for each page  $P$  at virtual address  $VA_p$ , `save_th` performs the following actions: concatenates the page contents ( $PC(P)$ ) with the address ( $PC(P)||VA_p$ ) and calculates its hash ( $H$ ). It then concatenates  $PC(P)$  with the hash and encrypts both using  $M_k$ . The encrypted packet is stored in BBuffer and the corresponding bits in `save_vec` and `internal save_vec` are updated.

**4.5.2 Restoring Data.** At the destination node, ConstMigLib restores data using `restore_th` (see Figure 5b). This thread retrieves encrypted data from the BBuffer, decrypts it within SGX using  $M_k$ , and extracts the page contents ( $PC(P)$ ) and hash ( $H$ ). It then calculates the expected hash ( $H'$ ) and validates that  $H == H'$ . If validation is successful, it stores the data on the corresponding page; otherwise, a security violation will be reported, and migration will be aborted

#### Algorithm 2 Validate Encrypt Packet

```

1: procedure VALIDATEENCRYPTPACKET( $C, VA, M_k$ )
2:   Check(restore_vec)
3:    $PC(P)||H \leftarrow \text{Decrypt}(C, M_k)$ 
4:    $H' \leftarrow \text{Hash}(PC(P)||VA)$ 
5:   if  $H = H'$  then Update(restore_vec)
6:     return true
7:   else
8:     return false
9:   end if
10: end procedure

```

(see Algorithm 2). Similar to `save_th`, `restore_th` maintains `restore_vec`, which tracks the restoration status of each page. After restoration, `restore_th` also sets the corresponding bit in `restore_vec`, marking the page that has been restored. If the bit in `restore_vec` was already set, a security violation is reported, and migration is aborted (see Invariant 4).

**Network page fault:** If the requested page is not available in BBuffer, CRIU issues a network page fault request to the source machine to retrieve the page, and `restore_th` enters



a blocked state. Upon receiving the request, the source machine’s CRIU signals `save_th` to save the page into `BBuff`. `save_th` first checks the internal `save_vec` data structure for the availability of the page in `BBuff`. A security violation occurs if the page is already saved and migration is aborted. `save_th` then encrypts the page using Algorithm 1 and stores it in `BBuff`. The encrypted page is then sent to the destination machine by CRIU. Upon receipt, `ConstMigLib` validates the encrypted content using Algorithm 2.

## 5 Fine-grained Access Tracking

A key challenge in migration is that the restored enclave and the SGX hardware are *not* migration-aware. The restored SGX enclave on the destination machine can access any memory region within its address space. If it attempts to access a memory location that is yet to be restored by `restore_th`, the enclave will fault and will be allocated a fresh zeroed data page by the fault handler instead of the page from the source machine (present in the encrypted form in a page on `BBuff`). We call this issue as *use-before-restore*. As discussed in Section 3, the `userfaultfd` mechanism that ensures that the data in `BBuff` is consistent *does not work for a memory region inside an enclave*. Page faults in the SGX secure region cannot be serviced using `userfaultfd` as it does not support device-backed memory pages (SGX pages are backed in device “`dev\isgx`” using out-of-tree SGX driver) in the Linux kernel [9, 10, 12, 13, 42].

**Two approaches:** To address this issue, we propose two novel schemes, namely, the `ConstMig` fault tracker and the `ConstMig` access tracker, that ensure a restored enclave reads valid data instead of a fresh all-zero page. The choice between the two depends on the extent of changes a vendor is able to implement in their system. The `ConstMig` fault tracker requires access to the page table, the ability to modify PTE entries, and the ability to issue TLB shootdowns. In contrast, the `ConstMig` access tracker requires access to the enclave’s source code and does not involve page table modifications.

### 5.1 ConstMig Fault Tracker

The first approach extends the SGX page fault handler to serve restored data instead of a fresh page on the destination machine. It leverages the fact that the operating system manages the page table of an enclave. A page fault is triggered if the application attempts to access a page that is yet to be allocated. The SGX fault handler services the fault and returns a zeroed page to the enclave. We modify the SGX fault handler to return a “restored” page instead of a zeroed page. Note that the SGX fault handler executes as a kernel module and can only read the encrypted data stored in `BBuff`. To write to a page resident inside an enclave with restored data, the enclave must decrypt, validate, and write the data.

As shown in Figure 6a, we modify the SGX driver ❶ to send a signal to the application on a fault. ❷ Upon receiving

the signal, the application makes an ECALL into the `ConstMigLib` enclave with the faulting address. `ConstMigLib` then checks if `restore_th` is currently restoring this page and if the fault is due to that. ❸ If the fault is not due to `restore_th`, `ConstMigLib` reads the encrypted page from `BBuff` (this, in turn, may cause a network page fault that is then transparently handled by CRIU), it then decrypts the page, validates its integrity, and ❹ writes the decrypted data to the faulting address. Now, the original faulting thread will see the restored data instead of all zeros. Note that there will be exactly one signal for every page in the enclave (either due to `restore_th` or a page fault in the enclave itself).

**Implementation:** We modify the `sgx_do_fault` function in the SGX driver to send a signal to the corresponding application upon a fault. The signal is sent *after* the fault is handled so that the page table has valid entries. In order to make the ECALL from the application to `ConstMigLib` upon receiving the signal, we implement a dedicated trusted thread in SGX SDK called `constmig_fault_thread` to service the page fault signals. This is *crucial* as the trusted thread, which caused the page fault earlier, is still waiting for the fault to be resolved and *cannot* be used to make an ECALL (we tested it, using this thread causes the enclave to crash).

Note that page faults are only generated for a fresh page allocation. There are no faults for “committed” pages as they are allocated during the enclave initialization itself. In order to ensure that there is a fault when the enclave accesses any of the committed pages for the first time, we set the `PROT_NONE` bit for all the committed pages using the `mprotect` [6] call. An `mprotect` call is allowed from outside the enclave for pages inside the enclave since it just updates the page table entries. In the current implementation, accessing a page with `PROT_NONE` set from within the enclave will cause the enclave to crash. We modify the function `sig_handler` in the trusted part of the SGX SDK (called `PSW` [58]) to handle these faults and send a signal to the application. The rest of the steps to handle the signal remain the same as before.

---

```

1 void traverseList(){
2   struct Node* pos = head;
3   __process_access(pos, sizeof(struct Node));
4   while(pos!=NULL){
5     __process_access(pos, sizeof(struct Node));
6     // use pos->val
7     pos = pos->next;
8   }
9 }

```

---

**Listing 1.** List traversal showing the added heap pointer access checks

### 5.2 ConstMig Access Tracker

The second approach is based on the idea of adding a “check” before every heap pointer access in the restored enclave (see

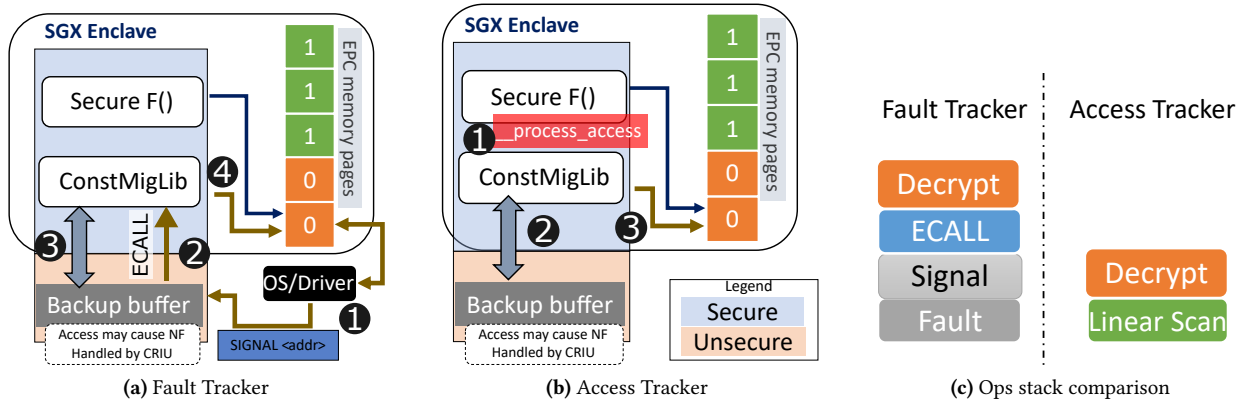

**Figure 6.** Figure showing two different approaches for fine-grained access tracking using page faults (a) or automatically added access checks (b) and the comparison of the steps required by both approaches. NF: Network faults.

Figure 6b). The check uses the information stored in MemArr to ensure that the pages about to be accessed by the enclave have been restored from BBuf. A sample code that shows the added check to restore a page using a function called `__process_access()` is shown in Listing 1. Note that the check is executing within the enclave and hence, requires no ECALL.

The function `__process_access()` takes two arguments: the pointer address from which the access will start and the access size. It does a linear scan of MemArr to find the memory region to which the current access request belongs. A linear scan is suitable when there are only a few allocated regions. However, for a large number of memory regions, a radix tree-like structure can be used for efficient lookups. Upon finding the correct memory region, it finds the pages on BBuf that must be restored to service the request using the location of the memory region on the BBuf, address, and the access size.

It then checks `restore_vec` to see if all the required pages have already been restored. If all of them have been restored, it returns; otherwise, it reads the encrypted pages from BBuf and restores the missing pages. Note that reading the encrypted pages on BBuf might raise network faults, which are transparently handled by CRIU. Once the restoration of all the pages is done (indicated by a global flag), the memory check is replaced with a `return 0;` statement.

**Implementation:** In order to add additional memory checks, we implement a Clang-based source-to-source transformer [5, 32]. This is a common approach to ensure the validity of a pointer before dereferencing it and has been used extensively [73, 74, 82, 82, 83]. Our transformer extends the `RecursiveASTVisitor` class in Clang to traverse the *abstract syntax tree* (AST) [1]. An AST is a tree representation of the constructs (variables, functions, etc.) in the source code. We use the AST tree to get information about heap variable usage. The `RecursiveASTVisitor` class in Clang offers standard APIs to process different kinds of nodes on the AST.

For example, the heap variable `pos` in Listing 1 shows up as a `DeclRefExpr` node in the AST. `DeclRefExpr` contains the name of the variable and also its type. Our transformer uses this information to add the `__process_access()` checks before accessing a variable.

### 5.3 Discussion

Both the approaches, Fault Tracker and Access Tracker, have their pros and cons (see Figure 6c). A Fault Tracker requires no enclave source code modification (apart from adding a signal handler in the untrusted part of the application); however, it is expensive because it involves sending a signal and making an ECALL. On the other hand, Access Tracker, although it requires enclave source code modification, is less overhead-prone because it does not require any signals or ECALLs (as the checks are done inside the enclave). The cost to restore a page (read from BBuf and decryption) is the same for both the approaches.

**5.3.1 Application to other TEE.** ConstMig can be applied to any TEE solution that supports remote attestation. Remote attestation is the key to ensuring that the new enclave spawned on the destination machine has not been tampered with and can be trusted with sensitive data from the enclave on the source machine.

## 6 Security Analysis

ConstMig prevents the following attacks during the migration process:

**Replay attack:** An adversary might intercept messages transmitted during migration and attempt to replay them to migrate the application to a compromised destination. However, at the start of the migration process, the source and destination nodes perform a remote attestation and the  $M_k$  (migration key) is securely transferred to the intended destination only.  $M_k$  is then used to encrypt the data during

transmission (see Invariant 5). While an adversary could replay the messages, they would be unable to decrypt the data without  $M_k$ , leading to migration failure. Moreover, ConstMig stops the secure application on the source machine after the key transfer, preventing re-migration to any other destination (see Invariant 3).

**Forking attack:** In a forking attack, the application is maliciously *forked* during a migration. However, the new instance will be unable to decrypt the pages without  $M_k$ , effectively preventing the attack. Additionally, the adversary cannot request the same data pages again, as ConstMigLib monitors all pages sent or received during migration and blocks any repeated requests (see Invariant 4). As a result, a forking attack is not feasible.

**Changing the Fault Address:** A malicious OS might attempt to leak data or disrupt execution by changing the faulting address. Suppose the restored enclave encounters a fault at address A, but the malicious OS on the destination machine maliciously reports the address as B (which has not yet been retrieved). Subsequently, the address B is sent in an encrypted message, and the contents of page B are retrieved from the source machine. Note that in this process, B cannot be changed (after it is reported to code running within SGX). Subsequently, the destination shall receive the contents of page B, which are guaranteed to be genuine (Invariant 1). The destination will write B’s contents to address B, which is correct. Of course, this does not service the network page fault and will immediately lead to a fault on the same address; however, the point to note is that the integrity of the process image is not compromised. This can lead to a delay but will not cause a security failure.

## 7 Evaluation

In this section, we compare ConstMig with the current state-of-the-art *MigSGX* [75]. All the other prior work is based on a similar migration scheme [50, 70, 76, 88]. We evaluate two configurations of ConstMig: ConstMig-V1, where an enclave is initialized with the maximum required memory and ConstMig-V2, where we leverage the EDMM capabilities of SGX and initialize an enclave with a smaller memory footprint; we add pages later as required (see §2). Table 4 shows the amount of committed memory used with *MigSGX*, ConstMig-V1, and ConstMig-V2.

Most of the workloads in our evaluation setup either do not issue a lot of `free()` calls or do so only for temporary buffers. Hence, we allocate most of the workloads with  $\approx 100$  MB to 200 MB of committed memory with the exception of OpenSSL. OpenSSL performs encryption of a file inside the enclave and frees the structure after finishing, and repeats the process. Hence, it is initialized with a 458 MB of committed pages. We saw no benefits in the performance for more than 458 MB of committed memory.

**Table 2.** Description of the workloads and the specific settings.

Workloads	Description	Input/Setting
BFS [86]	Traverse graphs generated by web crawlers. Use breadth-first search.	Nodes 150 K Edges 1.9 M
B-Tree [19]	Create a B-Tree and perform lookup operations on it.	Elements: 16 M
HashJoin [20]	Probe a hash-table (used to implement equijoin in DBs)	Look ups: 20 M
Key-Value [89]	Read and write operations on a key-value store.	Elements: 90 M
OpenSSL [77]	Encryption-decryption library.	File size: 1.1 GB
PageRank [86]	Assign ranks to pages based on popularity (used by search engines).	Nodes 5000 Edges 12.5 M
SVM [51]	Popular ML algorithm (application: text and hypertext categorization)	Rows 10000 Features 128

**Table 3.** Table comparing the cost of serving a page fault in the restored enclave using Fault Tracker and Access Tracker. All times are in  $\mu s$ .

	4KB		4MB	
	Fault Tracker	Access Tracker	Fault Tracker	Access Tracker
Decrypt	33	33	33,792	3,629
ECALL	8	–	8,192	–
Signal	8	–	8,397	–
Fault	2	–	2,253	–
<b>Total</b>	51	33	52,634	3,629

### 7.1 Experimental Setup

We use two 2-socket systems, each with two Intel Xeon Gold 6354 CPUs (72 cores), 1TB of memory, 512GB of SSD, 1 TB of HDD, and running Linux kernel 5.15. The systems are connected via a 1Gbps network. Both systems support scalable SGX with an EPC up to 64GB. We use Intel SGX SDX v2.13 and SGX driver [59] for our SGX setup. We use CRUI (Checkpoint and Restore In Userspace) [2], v3.16.1, as our migration manager. We use Clang 10 for the compiler pass. Table 2 shows the workloads used to evaluate ConstMig. Our changes are mainly limited to the SGX driver and SDK.

### 7.2 Fault Tracker v.s. Access Tracker

Table 3, shows the time taken by each step in Fault and Access Tracker for 4 KB data and 4 MB data, respectively. For 4 KB and 4 MB data, Access Tracker outperforms Fault Tracker by 35% and 93%, respectively. The performance improvement for Access Tracker grows with an increase in the size of the data to be restored. Fault Tracker operates at 4 KB granularity; hence, restoring 4 MB data will require  $\approx 1,000$  faults, signals, and ECALLs. Whereas, Access Tracker can potentially use the MemArr to restore the complete 4 MB region using a single ECALL. Since Access Tracker outperforms Fault Tracker, we use it for the rest of the experiments.

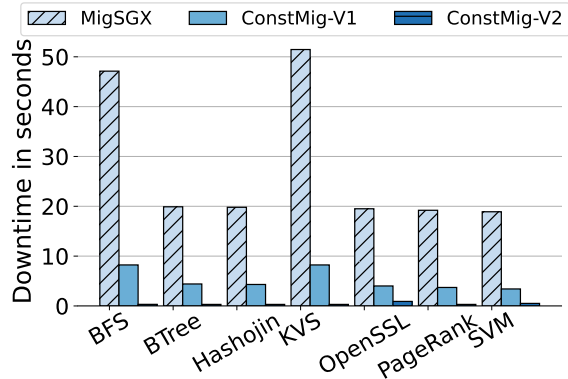

**Figure 7.** Total downtime using *MigSGX*, *ConstMig-V1*, and *ConstMig-V2* across workloads. The main cause of downtime in *MigSGX* is the transfer time, but in *ConstMig-V1*, it is the enclave *init* time.

### 7.3 Improvement in the Total Downtime

The asynchronous heap migration in *ConstMig*, which removes it from the critical path, translates to a significant reduction in the total downtime of an enclave. *ConstMig-V1* reduces the total downtime when compared with *MigSGX* by up to 84%. *ConstMig-V2* outperforms *ConstMig-V1* by up to 96%. The additional performance gains in *ConstMig-V2* are due to a reduction in the time of initialization of a fresh enclave on the destination machine (low amount of committed memory). Figure 7 shows an overview of the improvement in downtime of *ConstMig-V1* and *ConstMig-V2* compared to *MigSGX*.

### 7.4 End-to-End Performance (Single Migration)

Efficient migration also helps in improving the end-to-end performance, as the application is resumed almost instantly on the destination. In terms of the total end-to-end performance of the application being migrated (see Table 4). *ConstMig-V1* outperforms *MigSGX* by up to  $\approx 12.61\%$ . *ConstMig-V2* outperforms *MigSGX* by up to  $\approx 12.95\%$ . The end-to-end performance gain is due to a quick resumption of the application on the destination machine for *ConstMig-V1* and *ConstMig-V2*. Note that in *MigSGX*, once data restoration is complete, the application runs without any overhead. However, in *ConstMig*, even though the application starts responding almost immediately, there are performance overheads due to a background data restore and network page faults. In spite of this, *ConstMig* outperforms in terms of end-to-end performance.

### 7.5 Performance w.r.t. No Migration

In order to ensure that the enclave memory remains valid and consistent, we use a Clang compiler pass to add checks before accessing heap memory buffers. The check ensures that the page is present in the destination machine’s memory.

**Table 4.** Performance evaluation with *MigSGX*, *ConstMig-V1* (OM-v1), and *ConstMig-V2* (OM-v2). The performance improvement is for an end-to-end run.

	Setting	Committed Mem.	Init. Time	Total Exec. time	Perf. Imp. vs. MigSGX
BFS	<b>MigSGX</b>	5 GB	$\approx 8.1s$	293.4s	–
	<b>OM-v1</b>	5 GB	$\approx 8.1s$	256.4s	12.61%
	<b>OM-v2</b>	105 MB	$\approx 0.2s$	255.4s	12.95%
B-Tree	<b>MigSGX</b>	2 GB	$\approx 4.3s$	89.2s	–
	<b>OM-v1</b>	2 GB	$\approx 4.3s$	82.5s	7.51%
	<b>OM-v2</b>	105 MB	$\approx 0.2s$	80.5s	9.75%
Hash-Join	<b>MigSGX</b>	2 GB	$\approx 4.3s$	352.2s	–
	<b>OM-v1</b>	2 GB	$\approx 4.3s$	320.2s	9.09%
	<b>OM-v2</b>	105 MB	$\approx 0.2s$	318.2s	9.65%
Key-Value	<b>MigSGX</b>	5.3 GB	$\approx 8.3s$	448.2s	–
	<b>OM-v1</b>	5.3 GB	$\approx 8.3s$	416.1s	7.16%
	<b>OM-v2</b>	105 MB	$\approx 0.2s$	413.6s	7.72%
Open-SSL	<b>MigSGX</b>	2 GB	$\approx 4.3s$	122.1s	–
	<b>OM-v1</b>	2 GB	$\approx 4.3s$	114.3s	6.39%
	<b>OM-v2</b>	458 MB	$\approx 1s$	110.7s	9.34%
Page-Rank	<b>MigSGX</b>	2 GB	$\approx 4.3s$	183.2s	–
	<b>OM-v1</b>	2 GB	$\approx 4.3s$	176.4s	3.71%
	<b>OM-v2</b>	105 MB	$\approx 0.2s$	169.1s	7.70%
SVM	<b>MigSGX</b>	2 GB	$\approx 4.3s$	406.2s	–
	<b>OM-v1</b>	2 GB	$\approx 4.3s$	361.7s	10.96%
	<b>OM-v2</b>	205 MB	$\approx 0.4s$	358.1s	11.84%

If they are restored, it returns true; otherwise, it starts reading those pages from the source machine. Note that if the restoration is done or the application is not yet migrated, the checks return immediately after accounting for memory use. There is undoubtedly a small overhead involved; however, a lot of this gets hidden because of the predictability of the branch and the unused resources of out-of-order Intel CPUs. The counter increment and the *call/ret* pair of instructions can thus be easily accommodated. The *call/ret* pair is also a predictable sequence and this leads to hits in the RAS and BTB. The total overhead of doing so is limited to a maximum of 1.86% (see Table 5).

There are different works in the security domain where every pointer is validated before use. The validation process involves calculating the MAC of the pointer or other similar cryptographic operations [18, 104]. The overhead reported by them is around 4.29% for all SPECint benchmarks and 5% for gzip. Furthermore, it has been shown that these overheads can be brought down to less than  $< 1\%$  using hardware support [103].

Table 5 compares the performance overheads in *MigSGX*, *ConstMig-V1*, and *ConstMig-V2* compared to baseline execution (application executing in SGX, but no migration). Compared to the baseline setting, *ConstMig-V2* causes an average performance overhead of 34% in our testing setting. *MigSGX* causes a performance overhead of 49% over the baseline setting.

**Table 5.** Table showing end-to-end performance overhead due to: (i) additional memory checks only (no migration) (ii) with migration (*MigSGX*, *ConstMig-V1* (OM-v1), and *ConstMig-V2* (OM-v2)), vs no-migration.

	BFS	BTree	Hash Join	KVS	Open SSL	Page Rank	SVM
<b>Slowdown (in %) w.r.t Baseline (SGX + No migration). Lower is better</b>							
<i>MigSGX</i>	76.75	33.13	49.36	62.39	21.73	52.67	50.44
OM-v1	54.46	23.13	35.79	50.76	13.96	47.00	33.96
OM-v2	53.86	20.15	34.94	49.86	10.37	40.92	32.63
<b>+Mem Checks</b>	1.86	1.31	1.4	.6	.73	1.22	0.12

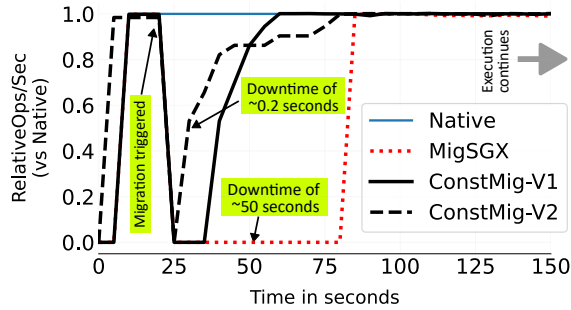

**Figure 8.** Figure showing the drop in the throughput of Key-Value when migrating the application with three different techniques: *MigSGX*, *ConstMig-V1*, and *ConstMig-V2*.

## 7.6 Throughput Results (Key-Value Store)

We use a key-value store (or KVS) workload [75] to report the observed throughput before, during, and post-migration (*MigSGX* has done the same). We compare the throughput of *ConstMig* with state-of-the-art. The KVS workload performs a fixed number of *set* and *get* operations in a single thread with a value of size 10KB. It reports the throughput that it observed. We report the throughput observed before, while, and after the migration. As shown in Figure 8, the throughput goes to zero when the application is frozen. However, the total downtime is much lower in *ConstMig* than in *MigSGX* (84% and 96% for *ConstMig-V1* and *ConstMig-V2*, respectively). Furthermore, we observe that post-migration, the observed throughput for *ConstMig-V2* is the same as that of native execution, whereas *ConstMig-V1* suffers a nominal overhead of 0.1%.

## 7.7 Network Page Faults

A network fault is issued if the restored application tries to access not-yet-migrated data pages. We measure the latency of a single network fault to be around 4-10 $\mu$ s. Table 6 shows the total network faults for three workloads: BFS, HashJoin, and SVM, with the highest network fault count. For the rest of the workloads, there are zero network page faults. The absence of any network page faults indicates that when

**Table 6.** Total number of network faults in different workloads with a *naive* placement of memory regions.

Workload	BFS	HashJoin	SVM	Rest
#NF	10,064	1,874	12,308	< 1000

the application tries to read a data page, the *save\_th* has already restored it. This pattern is common in workloads that sequentially access the data or have a tightly compressed organization of data (adjacent nodes of a tree are present in the same 4K page or nearby pages).

However, for workloads that can access data randomly or the data is not packed so tightly, there will be network page faults as the application accesses are scattered across the allocated address space. BFS, a graph search algorithm can reach any node in the tree with few hops. Similarly, in HashJoin, the hash table can be randomly indexed based on the key and the hash value. In SVM, the organization of the trained model is such that it needs to access different addresses scattered in the address space.

**Worst-case scenario:** In the worst-case scenario, during migration, every page access on the destination machine causes a network fault. In this case, the total migration time for *ConstMig* would exceed that of *MigSGX*. However, the total downtime for *MigSGX* will depend on data size, while for *ConstMig*, it will remain nearly constant.

## 7.8 Migration in Virtualized Environments

With the advent of lightweight virtualization techniques, customers deploy their stateful applications on docker containers and microVMs instead of standalone applications [62, 92]. We evaluate the performance of *ConstMig* using three different types of sandbox environments: Docker containers [46], Firecracker’s microVMs [22], and Qemu VM [80]. Our aim is to show the improvement in migrating a secure portion of the containers. Hence, we configure our benchmarks with a small untrusted memory footprint. Using a large amount of unsecure memory will overshadow the cost of migrating SGX enclave in the presence of sandboxes with high memory footprints.

Table 7 shows the total downtime of an application during migration from one machine to another in the cloud. A Docker container and a Firecracker’s microVM officially support the stop-and-copy migration technique [7]. In the case of Docker, we only transfer the anonymous memory pages over the network; therefore, the downtime is proportional to the input size. On the other hand, the downtime of a microVM is almost the same for all the benchmarks. This is because a microVM’s snapshot contains a memory file whose size is equal to the amount of memory that has been configured for the microVM. As a result, the cost of transferring the memory file over the network is the same for all benchmarks. The downtime for a VM increases by up to

**Table 7.** Performance evaluation of total downtime (DT) for ConstMig on an academic cloud setup. Here, DT includes downtime due to sandbox transfer and SGX enclave transfer. Memory in MB. We perform *live* VM migration.

Benchmark	Input Size (MB)	Downtime (seconds)		
		Docker	MicroVM	VM
BFS	9	4.81	12.56	16.4
B-Tree	64	12.98	12.56	28.69
Hash-Join	50	11.01	12.56	28.05
Key-Value	80	15.08	12.59	29.26
OpenSSL	80	15.08	12.59	29.26
Pagerank	80	15.08	12.59	29.26
SVM	24	7.32	12.56	27.05

**Table 8.** A summary of related work

Name	SDK	Method	Memory size
CloudMig [49]	Custom	Stop-and-Copy	≈32MB
Plinius [101]	Simulation	Stop-and-Copy & NVMM	MBs
MigGSX [75]	Intel	Stop-and-Copy & Pipeline	GBs
CTR [76]	Open Enclave	Stop-and-Copy & Pipeline	GBs
<i>ConstMig</i>	Intel	Post Copy	GBs

3.7× compared to other sandbox environments because the resident memory size increases by 14.25×. If these workloads are executed in a non-virtualized setting, the total downtime in ConstMig-V1 is ≈ 1s and in ConstMig-V2 is ≈ 0.2s, as the downtime is not impacted by the additional overheads due to the virtualization.

## 8 Related Work

Table 8 presents an overview of the prior work in this area. Gu et al. [49] and Yuhala et al. [101] use the stop-and-copy method to migrate SGX applications from one machine to another. The former focused on the efficient transfer of keys using a remote attestation process, while the latter focused on resuming machine learning applications in case of an application crash. Nakashima and Kourai [75] and Nakatsuka et al. [76], in their work *MigGSX* and *CTR*, respectively, do point out that the enclave size can be in GBs, and using the stop-and-copy method might require a large amount of memory. However, their main contribution is reducing the size of the unsecure buffer required to transfer the enclave data from one machine to another by employing pipelined memory transfer.

## 9 Conclusion

In this paper, we presented ConstMig— an efficient migration mechanism for large SGX enclaves. We showed the limitations of the current approaches that still use the decade-old

stop-and-copy migration mechanism for migrating SGX enclaves. Although suitable for small enclaves, this technique results in an unacceptable latency for large SGX enclaves. The main cause is a synchronous save and restore process. We presented an efficient and secure saving and restoring mechanism that enables asynchronous migration of enclave data. This essentially makes the downtime of an enclave constant during the migration, *irrespective of its size*.

Furthermore, we proposed two novel techniques to prevent the *use-before-restore issue in a restored enclave*. One technique overloads the SGX page fault handler and the second augments each memory access with an additional check. We implemented ConstMig and evaluated it on real-world applications. Our results show that ConstMig reduces the total downtime by 96% as compared to the state-of-the-art.

## References

- [1] Abstract syntax tree - wikipedia. [https://en.wikipedia.org/wiki/Abstract\\_syntax\\_tree](https://en.wikipedia.org/wiki/Abstract_syntax_tree). (Accessed on 06/29/2023).
- [2] Criu. [https://criu.org/Main\\_Page](https://criu.org/Main_Page). (Accessed on 02/03/2022).
- [3] Intel® xeon® gold 6354 processor. [Online; accessed 2025-01-16].
- [4] kernel.org/doc/documentation/vm/soft-dirty.txt. <https://www.kernel.org/doc/Documentation/vm/soft-dirty.txt>. (Accessed on 06/27/2023).
- [5] Modern source-to-source transformation with clang and libtooling - eli bendersky’s website. <https://tyny.to/sf1e87>. (Accessed on 06/19/2023).
- [6] mprotect(2) - linux manual page. <https://man7.org/linux/man-pages/man2/mprotect.2.html>. (Accessed on 05/21/2024).
- [7] Step-by-step guide to migrate docker containers | linuxandubuntu. <https://www.linuxandubuntu.com/home/migrate-docker-containers-to-new-server>. (Accessed on 11/16/2023).
- [8] tf-encrypted/tf-encrypted: A framework for encrypted machine learning in tensorflow. [Online; accessed 2025-01-13].
- [9] userfaultfd.h - include/uapi/linux/userfaultfd.h - linux source code (v6.3.7) - bootlin. <https://elixir.bootlin.com/linux/latest/source/include/uapi/linux/userfaultfd.h>. (Accessed on 06/11/2023).
- [10] userfaultfd\_k.h - include/linux/userfaultfd\_k.h - linux source code (v6.3) - bootlin. [https://elixir.bootlin.com/linux/v6.3/source/include/linux/userfaultfd\\_k.h](https://elixir.bootlin.com/linux/v6.3/source/include/linux/userfaultfd_k.h). (Accessed on 06/11/2023).
- [11] Intel Xeon Gold 5317 Processor 18M Cache 3.00 GHz Product Specifications. <https://ark.intel.com/content/www/us/en/ark/products/215272/intel-xeon-gold-5317-processor-18m-cache-3-00-ghz.html>, 2022. (Accessed on 01/29/2022).
- [12] The next steps for userfaultfd(). <https://lwn.net/Articles/718198/>, 2022. (Accessed on 02/03/2022).
- [13] Userfaultfd the linux kernel documentation. <https://www.kernel.org/doc/html/v6.3/admin-guide/mm/userfaultfd.html>, 2022. (Accessed on 06/11/2023).
- [14] Userfaultfd — the linux kernel documentation. <https://www.kernel.org/doc/html/latest/admin-guide/mm/userfaultfd.html>, 2022. (Accessed on 02/03/2022).
- [15] What Technology Change Enables 1 Terabyte (TB) Enclave Page Cache. <https://www.intel.com/content/www/us/en/support/articles/000059614/software/intel-security-products.html>, 2022. (Accessed on 01/29/2022).
- [16] Memory changes tracking - criu. [https://criu.org/Memory\\_changes\\_tracking](https://criu.org/Memory_changes_tracking), 2023. (Accessed on 06/27/2023).
- [17] mm: Ability to monitor task memory changes (v3) [lwn.net]. <https://lwn.net/Articles/546966/>, 2023. (Accessed on 06/27/2023).
- [18] Martín Abadi, Mihai Budiu, Úlfar Erlingsson, and Jay Ligatti. Control-flow integrity principles, implementations, and applications. *ACM*

- Trans. Inf. Syst. Secur.*, 13:4:1–4:40, 2009.
- [19] Reto Achermann. mitosis-project/mitosis-workload-btree: The btree workload used for evaluation. <https://github.com/mitosis-project/mitosis-workload-btree>, September 2020. (Accessed on 10/03/2020).
- [20] Reto Achermann. mitosis-project/mitosis-workload-hashjoin: The hashjoin workload used for evaluation. <https://github.com/mitosis-project/mitosis-workload-hashjoin>, September 2020. (Accessed on 10/03/2020).
- [21] Shaizeen Aga and Satish Narayanasamy. Invisipage: Oblivious demand paging for secure enclaves. In *Proceedings of the 46th International Symposium on Computer Architecture, ISCA '19*, page 372–384, New York, NY, USA, 2019. Association for Computing Machinery.
- [22] Alexandru Agache, Marc Brooker, Andreea Florescu, Alexandra Iordache, Anthony Liguori, Rolf Neugebauer, Phil Piwonka, and Diana-Maria Popa. Firecracker: Lightweight virtualization for serverless applications. In *Proceedings of the 17th Usenix Conference on Networked Systems Design and Implementation, NSDI'20*, page 419–434, USA, 2020. USENIX Association.
- [23] Fritz Alder, Arseny Kurnikov, Andrew Paverd, and N. Asokan. Migrating sgx enclaves with persistent state. In *2018 48th Annual IEEE/IFIP International Conference on Dependable Systems and Networks (DSN)*, pages 195–206, 2018.
- [24] Tiago Alves and Don Felton. Trustzone: Integrated hardware and software security. *ARM white paper* 3, 2004.
- [25] AMD. Confidential Guest Services with SVSM on SEV-SNP. *KVM Forum*, 2022.
- [26] Anati, Shay Gueron, Steven M. Johnson, and Vincent Scarlata. Innovative technology for cpu based attestation and sealing ittai. 2013.
- [27] Panagiotis Antonopoulos, Arvind Arasu, Kunal D. Singh, Ken Eguro, Nitish Gupta, Rajat Jain, Raghav Kaushik, Hanuma Kodavalla, Donald Kossman, Nikolas Ogg, Ravi Ramamurthy, Jakub Szymaszek, Jeffrey Trimmer, Kapil Vaswani, Ramarathnam Venkatesan, and Mike Zwilling. Azure sql database always encrypted. In *Proceedings of the 2020 ACM SIGMOD International Conference on Management of Data, SIGMOD '20*, page 1511–1525, New York, NY, USA, 2020. Association for Computing Machinery.
- [28] Emmanuel Arzuaga and David R Kaeli. Quantifying load imbalance on virtualized enterprise servers. In *Proceedings of the first joint WOSP/SIPEW international conference on Performance engineering*, pages 235–242, 2010.
- [29] Jean Bacon, David Evans, David M Eyers, Matteo Migliavacca, Peter Pietzuch, and Brian Shand. Enforcing end-to-end application security in the cloud: (big ideas paper). In *Middleware 2010: ACM/IFIP/USENIX 11th International Middleware Conference, Bangalore, India, November 29-December 3, 2010. Proceedings 11*, pages 293–312. Springer, 2010.
- [30] Andrew Baumann, Marcus Peinado, and Galen C. Hunt. Shielding applications from an untrusted cloud with haven. In *11th {USENIX} Symposium on Operating Systems Design and Implementation ({OSDI} 14)*, volume 33, pages 8:1–8:26, Broomfield, CO, oct 2014. {USENIX} Association.
- [31] Anton Beloglazov and Rajkumar Buyya. Energy efficient resource management in virtualized cloud data centers. In *2010 10th IEEE/ACM International Conference on Cluster, Cloud and Grid Computing*, pages 826–831. IEEE, 2010.
- [32] Eli Bendersky. Basic source-to-source transformation with clang - eli bendersky's website. <https://eli.thegreenplace.net/2012/06/08/basic-source-to-source-transformation-with-clang>. (Accessed on 06/19/2023).
- [33] Ferdinand Brasser, Srdjan Capkun, Alexandra Dmitrienko, Tommaso Frassetto, Kari Kostiaainen, and Ahmad-Reza Sadeghi. Dr. sgx: Automated and adjustable side-channel protection for sgx using data location randomization. In *Proceedings of the 35th Annual Computer Security Applications Conference*, pages 788–800, 2019.
- [34] Jo Van Bulck, Nico Weichbrodt, Rüdiger Kapitza, Frank Piessens, and Raoul Strackx. Telling your secrets without page faults: Stealthy page Table-Based attacks on enclaved execution. In *26th USENIX Security Symposium (USENIX Security 17)*, pages 1041–1056, Vancouver, BC, August 2017. USENIX Association.
- [35] Jo Van Bulck, Nico Weichbrodt, Rüdiger Kapitza, Frank Piessens, and Raoul Strackx. Telling your secrets without page faults: Stealthy page Table-Based attacks on enclaved execution. In *26th USENIX Security Symposium (USENIX Security 17)*, pages 1041–1056, Vancouver, BC, August 2017. USENIX Association.
- [36] Chia che Tsai, Donald E. Porter, and Mona Vij. Graphene-SGX: A practical library OS for unmodified applications on SGX. In *2017 USENIX Annual Technical Conference (USENIX ATC 17)*, pages 645–658, Santa Clara, CA, July 2017. USENIX Association.
- [37] Guoxing Chen, Sanchuan Chen, Yuan Xiao, Yinqian Zhang, Zhiqiang Lin, and Ten H Lai. Sgxpectre: Stealing intel secrets from sgx enclaves via speculative execution. In *2019 IEEE European Symposium on Security and Privacy (EuroS&P)*, pages 142–157. IEEE, 2019.
- [38] Pau-Chen Cheng, Wojciech Ozga, Enrique Valdez, Salman Ahmed, Zhongshu Gu, Hani Jamjoom, Hubertus Franke, and James Bottomley. Intel tdx demystified: A top-down approach. *ACM Comput. Surv.*, 56(9), apr 2024.
- [39] Pau-Chen Cheng, Wojciech Ozga, Enrique Valdez, Salman Ahmed, Zhongshu Gu, Hani Jamjoom, Hubertus Franke, and James Bottomley. Intel tdx demystified: A top-down approach. *ACM Comput. Surv.*, 56(9), April 2024.
- [40] Christopher Clark, Keir Fraser, Steven Hand, Jacob Gorm Hansen, Eric Jul, Christian Limpach, Ian Pratt, and Andrew Warfield. Live Migration of Virtual Machines. In *Proceedings of the 2nd Conference on Symposium on Networked Systems Design & Implementation - Volume 2, NSDI'05*, page 273–286, USA, 2005. USENIX Association.
- [41] Luigi Coppolino, Salvatore D'Antonio, Davide Iasio, Giovanni Mazzeo, and Luigi Romano. An experimental evaluation of tee technology evolution: Benchmarking transparent approaches based on sgx, sev, and tdx, 2024.
- [42] Jonathan Corbet. Improving page-fault scalability [lwn.net]. <https://lwn.net/Articles/932298/>, 2023. (Accessed on 06/21/2023).
- [43] Victor Costan and Srinivas Devadas. Intel sgx explained. *IACR Cryptology ePrint Archive*, 2016:86, 2016.
- [44] Morten Dahl, Jason Mancuso, Yann Dupis, Ben Decoste, Morgan Giraud, Ian Livingstone, Justin Patriquin, and Gavin Uhma. Private machine learning in tensorflow using secure computation, 2018.
- [45] Shufan Fei, Zheng Yan, Wenxiu Ding, and Haomeng Xie. Security vulnerabilities of sgx and countermeasures: A survey. *ACM Comput. Surv.*, 54(6), July 2021.
- [46] Developerschosen By Fortune. Docker: Accelerated container application development. 2023.
- [47] Song Fu. Failure-aware construction and reconfiguration of distributed virtual machines for high availability computing. In *2009 9th IEEE/ACM International Symposium on Cluster Computing and the Grid*, pages 372–379. IEEE, 2009.
- [48] Alexey Gribov, Dhinakaran Vinayagamurthy, and Sergey Gorbunov. Stealthdb: a scalable encrypted database with full SQL query support. *CoRR*, abs/1711.02279, 2017.
- [49] Jinyu Gu, Zhichao Hua, Yubin Xia, Haibo Chen, Binyu Zang, Haibing Guan, and Jinming Li. Secure Live Migration of SGX Enclaves on Untrusted Cloud. In *2017 47th Annual IEEE/IFIP International Conference on Dependable Systems and Networks (DSN)*, pages 225–236, 2017.
- [50] João Guerreiro, Rui Moura, and João Nuno Silva. TEEnd: SGX enclave migration using HSMs. *Computers & Security*, 96:101874, 2020.
- [51] Marti A. Hearst. Support vector machines. *IEEE Intelligent Systems*, 13(4):18–28, July 1998.

- [52] Michael R. Hines, Umesh Deshpande, and Kartik Gopalan. Post-copy live migration of virtual machines. *SIGOPS Oper. Syst. Rev.*, 43(3):14–26, jul 2009.
- [53] Matthew Hoekstra, Reshma Lal, and Pradeep Pappachan. Using innovative instructions to create trustworthy software solutions.
- [54] Cheng Hong, Zhicong Huang, Wen jie Lu, Hunter Qu, Li Ma, Morten Dahl, and Jason Mancuso. Privacy-preserving collaborative machine learning on genomic data using tensorflow, 2020.
- [55] Intel. Intel core i7-6700 processor. [Online; accessed 2025-01-15].
- [56] Intel. Performance considerations of hardware-isolated partitioned vms. [Online; accessed 2025-01-15].
- [57] Intel. White paper: Asynchronous enclave exit notify and the edecssa user leaf function. [Online; accessed 2025-01-15].
- [58] Intel. Intel sgx for linux\*. <https://github.com/intel/linux-sgx>, 2019. (Accessed on 09/23/2019).
- [59] Intel. Intel sgx linux\* driver. <https://github.com/intel/linux-sgx-driver>, 2019. (Accessed on 09/23/2019).
- [60] Intel. Intel software guard extensions | intel software. <https://software.intel.com/en-us/sgx>, 2019. (Accessed on 12/14/2019).
- [61] Intel. Intel trust domain extensions security research and assurance, aug 2024. [Online; accessed 2025-01-09].
- [62] Zhipeng Jia and Emmett Witchel. Boki: Stateful serverless computing with shared logs. In *Proceedings of the ACM SIGOPS 28th Symposium on Operating Systems Principles, SOSP '21*, page 691–707, New York, NY, USA, 2021. Association for Computing Machinery.
- [63] Hai Jin, Wei Gao, Song Wu, Xuanhua Shi, Xiaoxin Wu, and Fan Zhou. Optimizing the live migration of virtual machine by cpu scheduling. *Journal of Network and Computer Applications*, 34(4):1088–1096, 2011.
- [64] David Kaplan, Jeremy Powell, and Tom Woller. Amd memory encryption. *White paper*, page 13, 2016.
- [65] Gunjan Khanna, Kirk Beaty, Gautam Kar, and Andrzej Kochut. Application performance management in virtualized server environments. In *2006 IEEE/IFIP Network Operations and Management Symposium NOMS 2006*, pages 373–381. IEEE, 2006.
- [66] Sandeep Kumar, Abhisek Panda, and Smruti R. Sarangi. Securelease: Maintaining execution control in the wild using intel sgx. In *Proceedings of the 23rd ACM/IFIP International Middleware Conference, Middleware '22*, page 29–42, New York, NY, USA, 2022. Association for Computing Machinery.
- [67] Sandeep Kumar, Abhisek Panda, and Smruti R. Sarangi. Sgxxgauge: A comprehensive benchmark suite for intel sgx. In *2022 IEEE International Symposium on Performance Analysis of Systems and Software (ISPASS)*, pages 135–137, 2022.
- [68] Sandeep Kumar and Smruti R. Sarangi. Securefs: A secure file system for intel sgx. In *Proceedings of the 24th International Symposium on Research in Attacks, Intrusions and Defenses, RAID '21*, page 91–102, New York, NY, USA, 2021. Association for Computing Machinery.
- [69] Dayeol Lee, David Kohlbrenner, Shweta Shinde, Krste Asanović, and Dawn Song. Keystone: An open framework for architecting trusted execution environments. In *Proceedings of the Fifteenth European Conference on Computer Systems*, pages 1–16, 2020.
- [70] Hongliang Liang, Qiong Zhang, Mingyu Li, and Jianqiang Li. Toward Migration of SGX-Enabled Containers. In *2019 IEEE Symposium on Computers and Communications (ISCC)*, pages 1–6, 2019.
- [71] Masanori Misono, Dimitrios Stavrakakis, Nuno Santos, and Pramod Bhatotia. Confidential vms explained: An empirical analysis of amd sev-snp and intel tdx. *Proc. ACM Meas. Anal. Comput. Syst.*, 8(3), December 2024.
- [72] Arun Babu Nagarajan, Frank Mueller, Christian Engelmann, and Stephen L Scott. Proactive fault tolerance for hpc with xen virtualization. In *Proceedings of the 21st annual international conference on Supercomputing*, pages 23–32, 2007.
- [73] Santosh Nagarakatte, Milo M. K. Martin, and Steve Zdancewic. Everything you want to know about pointer-based checking. In *Summit on Advances in Programming Languages*, 2015.
- [74] Santosh Nagarakatte, Jianzhou Zhao, Milo M.K. Martin, and Steve Zdancewic. Softbound: Highly compatible and complete spatial memory safety for c. In *Proceedings of the 30th ACM SIGPLAN Conference on Programming Language Design and Implementation, PLDI '09*, page 245–258, New York, NY, USA, 2009. Association for Computing Machinery.
- [75] Kenji Nakashima and Kenichi Kourai. MigSGX: A Migration Mechanism for Containers Including SGX Applications. In *Proceedings of the 14th IEEE/ACM International Conference on Utility and Cloud Computing, UCC '21*, New York, NY, USA, 2021. Association for Computing Machinery.
- [76] Yoshimichi Nakatsuka, Ercan Ozturk, Alex Shamis, Andrew Paverd, and Peter Pietzuch. Ctr: Checkpoint, transfer, and restore for secure enclaves, 2022.
- [77] OpenSSL. Openssl. <https://www.openssl.org/>, 2019. (Accessed on 12/07/2019).
- [78] Alabi Orobosade, Thompson Aderonke Favour-Bethy, Alese Boniface Kayode, and Arome J Gabriel. Cloud application security using hybrid encryption. *Communications on Applied Electronics*, 7(33):25–31, 2020.
- [79] Christian Priebe, Kapil Vaswani, and Manuel Costa. Enclavedb: A secure database using sgx. In *2018 IEEE Symposium on Security and Privacy (SP)*, pages 264–278, 2018.
- [80] qemu. Qemu: A generic and open source machine emulator and virtualizer. 2023.
- [81] Jaak Randmets. An overview of vulnerabilities and mitigations of intel sgx applications. URL: <https://cyber.ee/research/reports/D-2-116-An-Overview-of-Vulnerabilities-and-Mitigations-of-Intel-SGX-Applications.pdf>, 2021.
- [82] Alexander Richardson. Complete spatial safety for c and c++ using cheri capabilities. 2020.
- [83] Gururaj Saileshwar, Richard H. Boivie, Tong Chen, Benjamin Segal, and Alper Buyuktosunoglu. Heapcheck: Low-cost hardware support for memory safety. *ACM Transactions on Architecture and Code Optimization (TACO)*, 19:1 – 24, 2022.
- [84] Michael Schwarz, Samuel Weiser, Daniel Gruss, Clémentine Maurice, and Stefan Mangard. Malware guard extension: Using sgx to conceal cache attacks. In *Detection of Intrusions and Malware, and Vulnerability Assessment: 14th International Conference, DIMVA 2017, Bonn, Germany, July 6-7, 2017, Proceedings 14*, pages 3–24. Springer, 2017.
- [85] Avital Shafran, Gil Segev, Shmuel Peleg, and Yedid Hoshen. Crypto-oriented neural architecture design, 2021.
- [86] Julian Shun and Guy E. Blelloch. Ligma: A lightweight graph processing framework for shared memory. *SIGPLAN Not.*, 48(8):135–146, February 2013.
- [87] Ashish Singh and Kakali Chatterjee. Cloud security issues and challenges: A survey. *Journal of Network and Computer Applications*, 79:88–115, 2017.
- [88] Claudio Soriente, Ghassan Karame, Wenting Li, and Sergey Fedorov. ReplicaTEE: Enabling Seamless Replication of SGX Enclaves in the Cloud. In *2019 IEEE European Symposium on Security and Privacy (EuroSP)*, pages 158–171, 2019.
- [89] Vikram Sreekanti, Chenggang Wu, Xiayue Charles Lin, Johann Schleier-Smith, Joseph E. Gonzalez, Joseph M. Hellerstein, and Alexey Tumanov. Cloudburst: Stateful Functions-as-a-Service. *Proc. VLDB Endow.*, 13(12):2438–2452, jul 2020.
- [90] Alexander Stage and Thomas Setzer. Network-aware migration control and scheduling of differentiated virtual machine workloads. In *2009 ICSE Workshop on Software Engineering Challenges of Cloud Computing*, pages 9–14. IEEE, 2009.
- [91] Radostin Stoyanov and Martin Kollingbaum. Efficient live migration of linux containers. 06 2018.
- [92] Joe Stubbs, Walter Moreira, and Rion Dooley. Distributed systems of microservices using docker and serfnode. In *2015 7th International*



- Workshop on Science Gateways*, pages 34–39. IEEE, 2015.
- [93] Contributors to Wikimedia projects. Software guard extensions - wikipedia, 4 2015. [Online; accessed 2025-01-15].
  - [94] Florian Tramer and Dan Boneh. Slalom: Fast, verifiable and private execution of neural networks in trusted hardware. In *International Conference on Learning Representations*, 2019.
  - [95] P Troger and F Salfner. Timely virtual machine migration for proactive fault tolerance. In *14th IEEE International Symposium*, 2011.
  - [96] Ranjan Sarvangala Venkatesh, Till Smejkal, Dejan S. Milojevic, and Ada Gavrilovska. Fast in-memory criu for docker containers. In *Proceedings of the International Symposium on Memory Systems, MEMSYS '19*, page 53–65, New York, NY, USA, 2019. Association for Computing Machinery.
  - [97] William Voorsluys, James Broberg, Srikumar Venugopal, and Rajkumar Buyya. Cost of virtual machine live migration in clouds: A performance evaluation. In *Cloud Computing: First International Conference, CloudCom 2009, Beijing, China, December 1-4, 2009. Proceedings 1*, pages 254–265. Springer, 2009.
  - [98] Wei Wang, Isaku Yamahata, Ravi Sahita, Jun Nakajima, Dror Caspi, Jiewen Yao, and Haidong Xia. TDX Live Migration. *Linux Plumbers Conference*, 2021.
  - [99] Yongzhi Wang, Yulong Shen, Cuicui Su, Jiawen Ma, Lingtong Liu, and Xuewen Dong. Cryptsqlite: Sqlite with high data security. *IEEE Transactions on Computers*, 69(5):666–678, 2020.
  - [100] Yuanzhong Xu, Weidong Cui, and Marcus Peinado. Controlled-channel attacks: Deterministic side channels for untrusted operating systems. In *Proceedings - IEEE Symposium on Security and Privacy*, volume 2015-July, 2015.
  - [101] Peterson Jr Yuhala, Pascal Felber, Valerio Schiavoni, and Alain Tchana. Plinius: Secure and Persistent Machine Learning Model Training. pages 52–62, 06 2021.
  - [102] Ei Phyu Zaw and Ni Lar Thein. Improved live vm migration using lru and splay tree algorithm. *International journal of computer science and telecommunications*, 3(3):1–7, 2012.
  - [103] Jiliang Zhang, Binhang Qi, Zheng Qin, and Gang Qu. Hcic: Hardware-assisted control-flow integrity checking. *IEEE Internet of Things Journal*, 6(1):458–471, 2019.
  - [104] Mingwei Zhang and R. Sekar. Control flow integrity for COTS binaries. In *22nd USENIX Security Symposium (USENIX Security 13)*, pages 337–352, Washington, D.C., August 2013. USENIX Association.

## A Artifact for dirty bit evaluation

The source code for evaluation can be downloaded from here: <https://zenodo.org/records/14677356>.

### A.1 Pre-Requirement

The system should satisfy the following hardware and software requirements:

1. An Intel SGX machine with Intel SGX SDK and Intel SGX platform software installed.
2. Python
3. Root privileges to access the pagemap.

### A.2 Code structure

The evaluation code base consists of the following files:

1. `py_tracker.cpp`: Tracks the dirty bits of a given pid and address ranges using the pagemap interface.
2. `normal_app.cpp`: Traditional non-SGX application.

3. `SecureApp/`: A directory that contains an SGX-based application.

To run the `py_tracker.cpp` file in the background, the user must have root permissions. When executing the `normal_app.cpp` file, the user should observe that the tracker successfully tracks the dirty memory pages. However, when the secure application is executed, the tracker will be unable to detect dirty memory pages.

### A.3 How to run

Please see the README file in the code.

### A.4 Monitoring PageMap

The code in Listing 2 shows the code that opens the pagemap file from the proc interface for a given pid and reads the dirty bits from the specified address range.

---

```

...
pagemap_path = f'/proc/{pid}/pagemap'
with open(pagemap_path, 'rb') as f:
    f.seek(start_page * 8) # Each entry is 8
    bytes
    for page in range(start_page, end_page):
        entry = f.read(8)
        if not entry:
            break
        pte = struct.unpack('Q', entry)[0]
        soft_dirty = (pte >> 55) & 1 # Check
            bit 55
...

```

---

**Listing 2.** Reading of dirty bit given a pid and address range.