

Towards Quantum-Native Communication Systems: New Developments, Trends, and Challenges

Xiaolin Zhou, *Member, IEEE*, Anqi Shen, Shuyan Hu, Wei Ni, *Senior Member, IEEE*, Xin Wang, *Fellow, IEEE*, Ekram Hossain, *Fellow, IEEE*, and Lajos Hanzo, *Life Fellow, IEEE*

Abstract—The potential synergy between quantum communications and future wireless communication systems is explored. By proposing a quantum-native or quantum-by-design philosophy, the survey examines technologies such as quantum-domain multiple access (NOMA), quantum secure direct communication (QSDC), quantum resource allocation, quantum routing, and quantum artificial intelligence (AI). The recent research advances in these areas are summarized. Given the behavior of photonic and particle-like Terahertz (THz) systems, a comprehensive system-oriented perspective is adopted to assess the feasibility of using quantum communications in future systems. This survey also reviews quantum optimization algorithms and quantum neural networks to explore the potential integration of quantum communication and quantum computing in future systems. Additionally, the current status of quantum sensing, quantum radar, and quantum timing is briefly reviewed in support of future applications. The associated research gaps and future directions are identified, including extending the entanglement coherence time, developing THz quantum communications devices, addressing challenges in channel estimation and tracking, and establishing the theoretical bounds and performance trade-offs of quantum communication, computing, and sensing. This survey offers a unique perspective on the potential for quantum communications to revolutionize future systems and pave the way for even more advanced technologies.

Index Terms—Quantum communications, future wireless communication system, quantum-native, quantum-by-design architecture

I. INTRODUCTION

A. Background

The growing demand for high-quality, confidential information services is driving the rapid development of wireless communication systems and inspiring transformative innovation in information technologies. Following the global roll-out of the fifth-generation (5G) wireless systems, the community’s research efforts are becoming refocussed towards future wireless systems, including the sixth-generation (6G) systems and beyond [2], [3]. For example, according to the schedule of

X. Zhou, A. Shen, S. Hu, and X. Wang are with the Key Laboratory for Information Science of Electromagnetic Waves, School of Information Science and Technology, Fudan University, Shanghai 200433, China (E-mail: zhouxiaolin@fudan.edu.cn; 21110720067@m.fudan.edu.cn; syhu14@fudan.edu.cn; xwang11@fudan.edu.cn).

W. Ni is with Data61, Commonwealth Scientific and Industrial Research Organization (CSIRO), Sydney, NSW 2122, Australia (E-mail: wei.ni@csiro.au).

E. Hossain is with the University of Manitoba, Winnipeg, MB R3T 2N2, Canada (E-mail: ekram.hossain@umanitoba.ca).

L. Hanzo is with Communications, Signal Processing and Control Group, School of ECS, University of Southampton, Southampton SO17 1BJ, U.K. (E-mail: lh@ecs.soton.ac.uk).

TABLE I
ACRONYMS AND ABBREVIATIONS

Acronym	Full form
AI	Artificial Intelligence
AP	Access Point
CVQKD	Continuous-Variable Quantum Key Distribution
FSO	Free-Space Optical
HAP	High-Altitude Platform
HL	Helstrom Limit
IDMA	Interleave Division Multiple Access
IoT	Internet of Things
ISAC	Integrated Sensing and Communications
LEO	Low-Earth-Orbit
MCF	Multi-Core Fiber
MIMO	Multi-Input Multi-Output
MmWave	Millimeter Wave
NFV	Network Functions Virtualization
NG	Next-Generation
NISQ	Noisy Intermediate-Scale Quantum
NOMA	Non-Orthogonal Multiple Access
POVM	Positive Operator-Valued Measure
QBER	Quantum Bit Error Rate
QCL	Quantum Cascade Laser
QECC	Quantum Error Correction Code
QEM	Quantum Error Mitigation
Qinternet	Quantum Internet
QKD	Quantum Key Distribution
QMAN	Quantum Metropolitan Area Network
QoS	Quality-of-Service
QRNG	Quantum Random Number Generators
QSDC	Quantum Secure Direct Communication
QSIC	Quantum Secure Indirect Communication
QTC	Quantum Turbo Code
Qubit	Quantum Bit
RCWA	Routing, Core, and Wavelength Allocation
SDN	Software-Defined Networking
SIC	Successive Interference Cancellation
SQL	Standard Quantum Limit
SRM	Square-Root Measurement
THz	Terahertz
UAV	Unmanned Aerial Vehicle
VLC	Visible Light Communication
VNF	Virtual Network Function
VR/AR	Virtual/Augmented Reality

the Third Generation Partnership Project (3GPP), it will start standardizing 6G technology in the second half of 2025 [4], and the technology is expected to be commercially available globally around 2030. The capabilities of 6G communications will exceed the communication requirements of 5G and accelerate the digital transformation of society and economy [5], facilitating a quantum-leap from the connected things of the 5G era to connected intelligence [6] and realizing the vision of “intelligent connection of everything and digital twin” [7]–[10]. 6G networks are also expected to provide an integrated

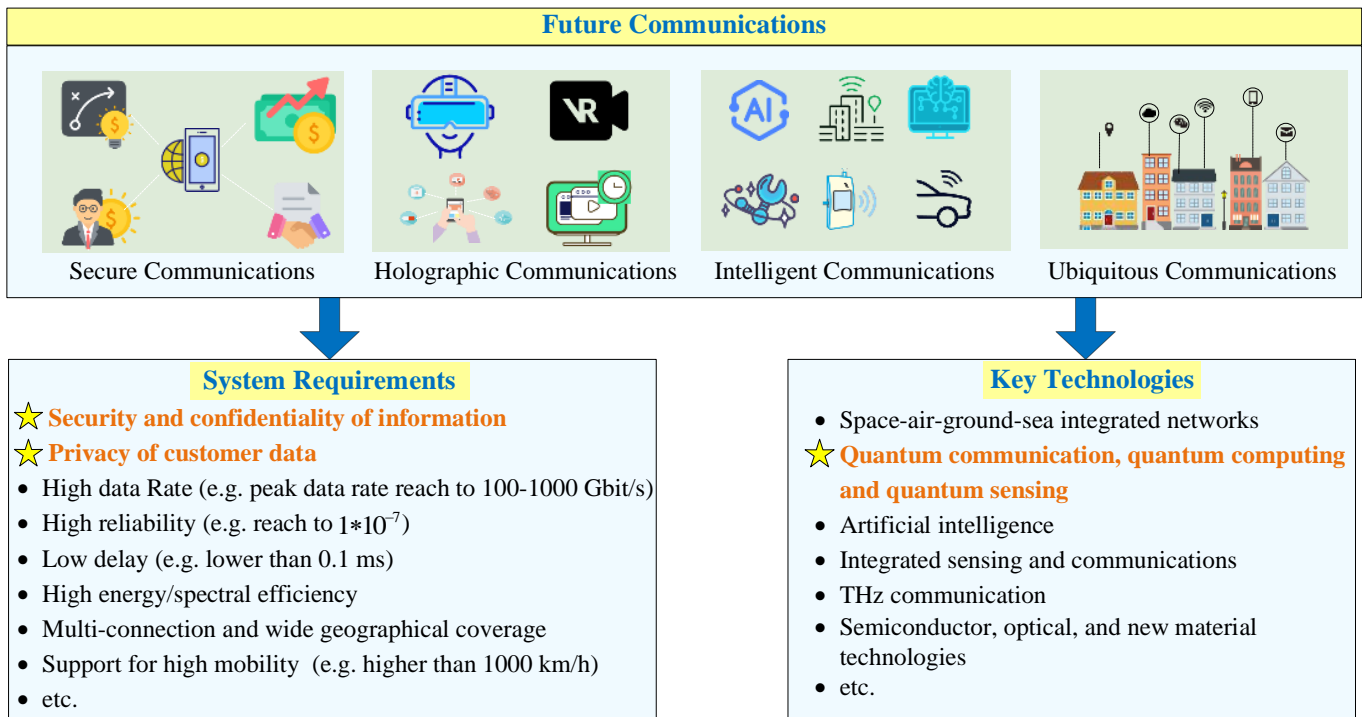

Fig. 1. A communication vision, the related system requirements, and key technologies. With the rapid development of communication technology, future communications will pay more attention to the security of information and the privacy of customer data. By utilizing quantum communication, quantum computing, quantum sensing, AI, and other new technologies, future communication networks are expected to offer secure, holographic, intelligent, and ubiquitous communication services [1].

space, air, ground, and sea network with unlimited coverage in support of high-speed user mobility [11], [12].

Immersive, intelligent, and multi-domain operation is expected to be the key features of future communications [11], [13], with some critical application scenarios including, but not limited to:

- Smart cities with intelligent super-connectivity and stringent security requirements [14], [15];
- Holographic communication supporting extremely high throughput and ultra-low latency as well as immersive extended reality (XR) experience [16];
- Near-real-time digital twin with ultra-high reliability [8];
- Seamless and ubiquitous high-speed Internet access in the air at high velocity [17];
- Networked unmanned driving support based on artificial intelligence (AI) for autonomous vehicles [18];
- Support of intelligent industry with the aid of ultra-high bandwidth, ultra-low delay and ultra-reliability [19];
- Universal emergency communication for rescue with full coverage [20].

As shown in Fig. 1, future systems are expected to offer secure, holographic, intelligent, and ubiquitous communication coverage [1]. It is anticipated that future communication systems are expected to pay more attention to communication security and to the protection of user privacy. Potential key technologies, such as quantum communication, will provide improved security in future communication networks. Furthermore, quantum technologies can also play an important role in improving transmission data rate and reliability, etc.

In more detail, for future networks, some important quantum-related research topics are included as:

- Quantum communications is a field of engineering that involves the exchange of quantum states representing quantum keys, for example [21]. This involves the use of quantum mechanical phenomena such as superposition and entanglement to transport quantum states from one place to another. To fully exploit these resources, the transferred state must remain unobserved during transmission, which prohibits copying or amplification during transmission [22].
- Quantum computing relies on quantum bits (Qubits) as the basic unit of information, rather than classical bits. Quantum computers operate by harnessing the laws of quantum mechanics [23] and are able to perform specific types of calculations much faster than classical computers. The potential for quantum computers to solve specific problems that are intractable for classical computers has led to considerable research [24].
- Quantum sensing relies on the principles of quantum mechanics to measure and transform physical quantities. These sensors take advantage of the unique phenomena that occur at the quantum level, such as quantum entanglement [25], quantum coherence [26], and quantum state squeezing [27]. Quantum sensors can be much more sensitive and accurate than classical sensors [6], [28].
- Quantum circuitry comprises interconnected quantum gates that manipulate qubits, which are arranged in a specific pattern for mitigating the avalanche-line prolif-

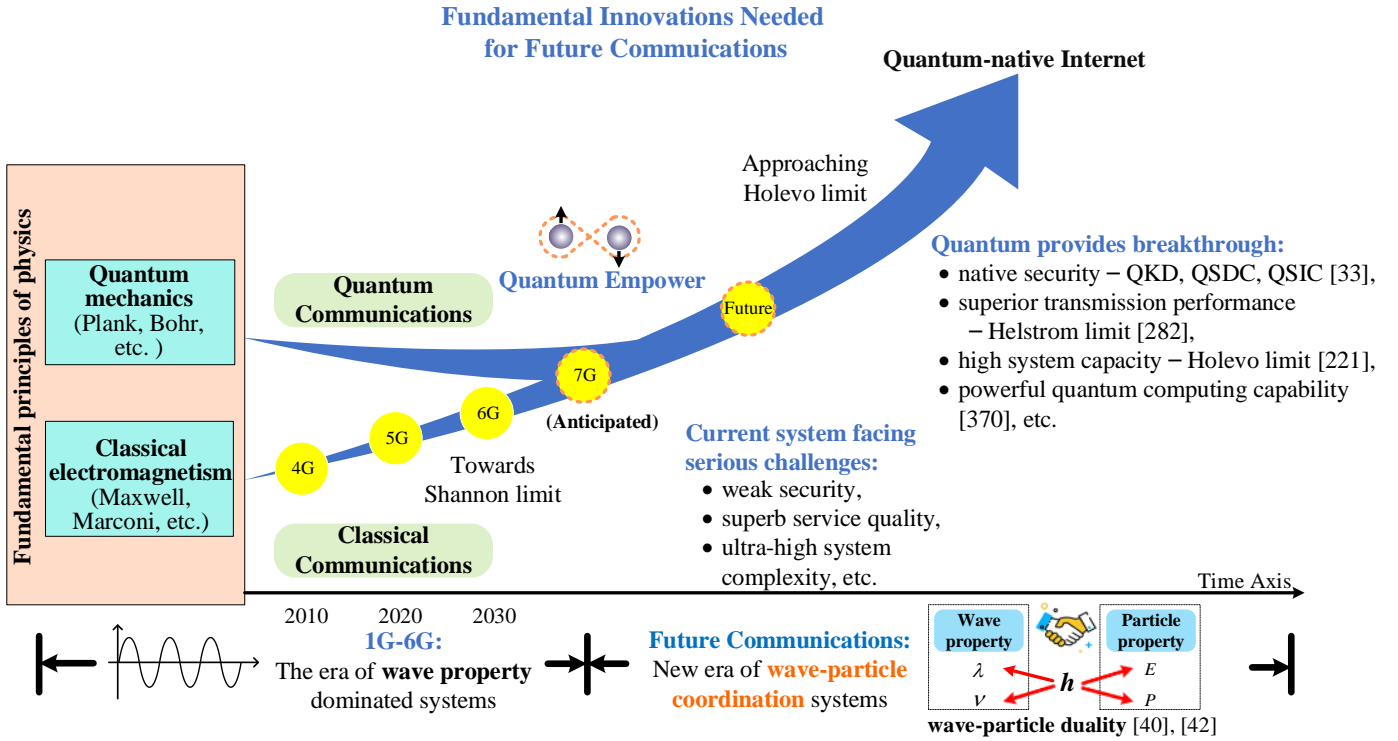

Fig. 2. Quantum communication boosts communication development and evolves to the future. In future communication systems, quantum communication can play an increasingly important role. In the future, the communication network can evolve into a quantum network to achieve a high degree of unity of the wave-particle duality physical law in the communication system. And with the development of classical and quantum communications, the deep integration of these two systems will be realized in the future, and finally, the Qinternet. In this figure, $E = h\nu$, $P = h/c\lambda$, where E represents energy, P represents momentum, h is the Planck's constant, ν denotes frequency, and λ denotes wavelength.

eration of qubit errors imposed by the deleterious effects of quantum decoherence [29].

- Quantum teleportation is a process that enables the transfer of quantum information, in the form of qubits, from one location to another, while relying on classical-domain (CD) assistance. This is made possible through the use of quantum entanglement, a phenomenon in which two or more particles become connected in such a way that the quantum state of one particle can influence that of the other, even if they are far apart. Quantum entanglement allows the qubits to be transferred from one location to another instantaneously, as if they were teleported [30]. But again, because of the reliance on CD operations, the speed of light cannot be exceeded.
- Quantum communication protocols are methods conceived for transmitting information carried by quantum states by exploiting the principles of quantum mechanics [31]–[33]. Some examples are quantum key distribution (QKD) and quantum secure direct communication (QSDC). Quantum communication protocols provide secure communication with applications in areas, e.g., cryptography, networking, and computing. However, QKD only represents the negotiation of secret keys, which are then used in a similar way to its classical encryption counterpart by taking the module-two connection of the data and the key. By contrast, QSDC constitutes a fully-fledged quantum communication protocol originally pro-

posed by Long and Liu [34]. This protocol has rapidly evolved in recent years [35].

B. Synergy of Quantum and Classical Systems

As shown in Fig. 2, it is anticipated that quantum communications and classical communications will co-evolve, providing candidate technologies for future networks [36], [37]. To be more specific, quantum communications will empower classical communications. For example, the natural security of quantum communications can support the demanding security requirements of future classical communications (e.g., financial stock trading) [38].

In general, the nano-scale world may be viewed as being governed by quantum theory. Hence, the laws of quantum mechanics prevail. By contrast, the physical phenomena of the classical world may be described by classical Newtonian theory. The classical world is characterized by the fact that the physical quantities and states of objects are completely determined at any given moment. By contrast, in the quantum world, the states are probabilistic, and the associated uncertainty has nothing to do with experimental technology. This feature is embodied in the principle of superposition of quantum states. Therefore, our discussions will cover both quantum-domain (QD) and CD signals, and we will consistently make a distinction between them.

The CD signal processing methods of the first-generation (1G) to 5G systems have been designed to mitigate the impair-

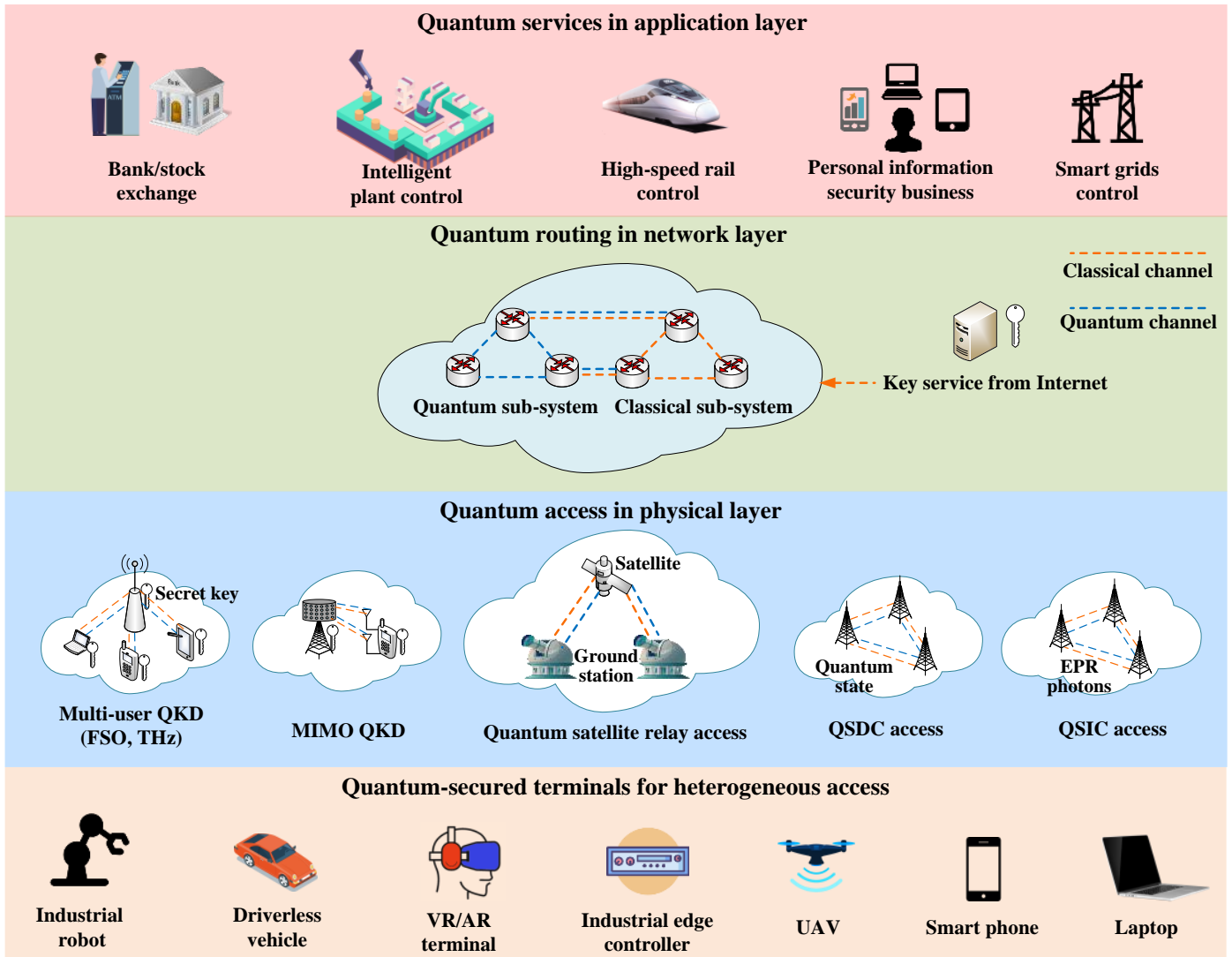

Fig. 3. A quantum secure communication system structure. The integration of quantum information technology and future networks will be a long-term development process. In the future, there will appear quantum-secured terminals for heterogeneous access. Quantum-secured technologies, such as QKD, QSDC, and QSIC, can be used for quantum access in the physical layer. In the network layer, quantum AI and quantum computing can be applied for quantum routing. And with the development of quantum technology, it will take full advantage of the application layer.

ment of electromagnetic waves. However, in future communication systems, quantum communication is expected to play an increasingly important role by exploiting the wave-particle duality of physics [39], [40] in practical communication systems. As illustrated in Fig. 2, the confluence of classical and quantum communications is expected to illuminate the conception of the quantum Internet (Qinternet).

Compared to the operational 4G and 5G communication systems, future systems are expected to adopt a more open framework. In this spirit, both wireless optical communications and visible light communications are conducive to the employment of quantum communications in higher frequency bands [41], where the particle-like characteristics of electromagnetic waves are more pronounced according to quantum physics [42]. In this context, the Terahertz (THz) band [43], ranging from 0.3 THz to 3 THz, exhibits strong quantum-like behaviors and particle characteristics.

There are increasing discussions in the quantum research community about exploiting the THz band for supporting quantum communications [44]. The quantum behavior of THz signals in silicon has also been investigated [45]. Existing experiments and engineering implementations of quantum communications have typically been dedicated to optical fibers [46], wireless laser channels [47] and the THz band [44]. Another reason for considering quantum communications in future systems, especially in the context of optical links, is the benefit of the relative maturity and cost efficiency of optical quantum devices, which is important for the larger-scale deployment and roll-out of future networks in a cost-effective way [48].

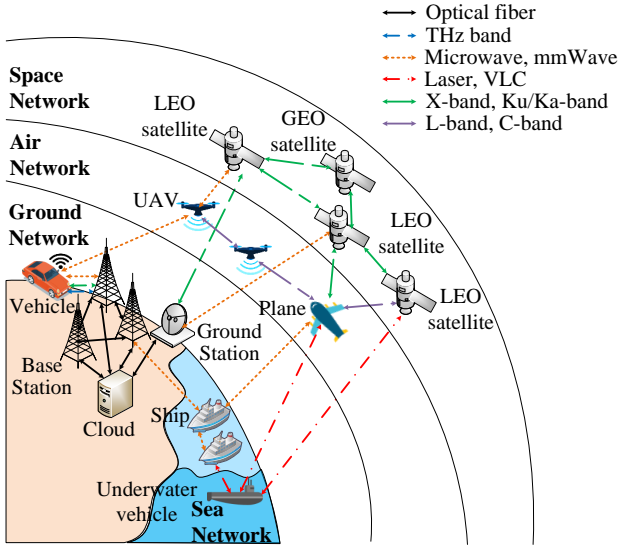

Fig. 4. Future space-air-ground-sea integrated secure communication network model. The future full-band communication network will cover different interface media, such as optical fiber, THz, microwave and mmWave, laser and VLC, X-band and Ku/Ka-band, L-band and C-band. They will provide the security, connectivity, reliability and throughput needed for future communication systems [49]–[51].

C. Security of Quantum Encryption and Eavesdropping Prevention

Fig. 3 portrays a quantum-secured technologies-based communication system architecture. Quantum-secured technologies, such as QKD, QSDC, and quantum secure indirect communication (QSIC), can be used for quantum access in the physical layer and realize secure communication. Their quantum-secured terminals will appear for heterogeneous access, such as industrial robots, driverless vehicles, industrial edge controllers, virtual/augmented reality (VR/AR) terminals, and even smartphones and laptops. Subsequently, with the emergence of room-temperature quantum computing devices, quantum AI and quantum computing can be applied to form the network layer for resource scheduling and quantum routing [6]. Finally, with the development of quantum technology, it will take full advantage in the application layer. For example, it can service bank/stock exchange, intelligent plant control, high-speed rail control, personal information security business, smart grid control and other scenarios with high-security requirements.

Quantum cryptography offers a high level of security in communication systems by exploiting the principles of quantum physics and statistical theory. One of its most significant advantages is its ability to detect eavesdropping using quantum technology, making it an ideal choice for confidential data communication [52]. QKD, a technique used in quantum cryptography, allows for the secure exchange of cryptographic keys that are distributed unconditionally. Compared to classical cryptography, quantum cryptography significantly reduces the likelihood of data interception and tampering, making it a superior option for secure communication [52].

To elaborate on the anti-eavesdropping capability of QKD

protocols, Lee *et al.* [53] analyzed the reliability of eavesdropping detection in the Bennett-Brassard-84 (BB84) QKD protocol using Hoeffding’s inequality. The study found a trade-off between the accuracy of eavesdropping detection and the frugality in the quantum resources used by the BB84 protocol. Nevertheless, the ability of quantum technology to detect eavesdropping is a beneficial feature of classical methods.

The secure exchange of cryptographic keys is crucial in communication systems, and QKD provides an exceptional means of ensuring unconditional security in key exchange. Any unauthorized tampering with legitimate communication on a QKD link directly increases the error rate, alerting both the transmitter and receiver. This becomes possible by exploiting the principles of quantum mechanics, making QKD a superior option for secure data communication [54]. Kamran *et al.* [54] demonstrated the advantages of using dynamic spatial modes in QKD systems through the design and implementation of the KMB09 protocol using Laguerre-Gaussian orbital angular momentum (OAM) based techniques. The protocol’s error rate is analyzed in detail, considering two different types of eavesdropping error rates. This protocol demonstrates the ability of quantum technology to detect and prevent eavesdropping, making it an ideal choice for secure communication. As a further advance, Castro *et al.* [55] proposed a modified BB84 QKD protocol that relies on the disentropy of the autocorrelation function for detecting eavesdropping. The randomness of the bit sequence obtained by Bob after the basis reconciliation stage is calculated in order to detect eavesdropping. This protocol offers an additional layer of security to the already secure quantum communication system, making it a beneficial design option for secure data communication.

QSDC is a branch of quantum communication that enables the direct transmission of secret messages over a quantum channel using single photons [56]. QSDC is characterized by theoretically perfect information security. However, in practice, the imperfections of optical devices can leave loopholes for quantum attacks. To address this, Liu *et al.* [57] carried out the associated quantum bit error rate (QBER) analysis and decoy-state photon transmission rate analysis. As a further development, Pan *et al.* [56] proposed a new single-photon-memory QSDC scheme based on a two-step QSDC protocol. They also carried out the security analysis of their scheme in the face of both direct measurement attacks, intercept-resend attacks, and opaque attack strategies. They demonstrated that none of these constitute a threat.

Numerous researchers have proposed various QSDC protocols that can resist multiple external attacks to improve security. To elaborate, Zhou *et al.* [58] proposed a three-party QSDC protocol associated with hyperentanglement under polarization and two spatial longitudinal momentum degrees of freedom. Their analysis indicates that inserting decoy photons for eavesdropping detection lends the proposed protocol improved security and can resist multiple external attacks. Deterministic secure quantum communication (DSQC) is another branch of QSDC that uses classical bits to transmit secret messages. In this context, Guo *et al.* [59] proposed a bidirectional multi-party DSQC scheme based on d-dimensional

k-particle Greenberger-Horne-Zeilinger (GHZ) states. They use added d-dimensional single photons for eavesdropping detection and extend the scheme to a network in support of high-rate communication of secret messages across regions.

Based on eight entangled quantum states, Jiang *et al.* [60] proposed a verifiable quantum secret-sharing protocol of three parties. Their security analysis shows that the quantum secret-sharing protocol advocated is secure against both internal and external attacks, which is an explicit benefit of using decoy states and of the randomness of the message. Finally, Gong *et al.* [61] presented a method for in-service optical, physical layer security monitoring, which is achieved by sending a QD signal consisting of continuously variable quantum states. This quantum-based method of eavesdropping detection is potentially more compatible with the operational optical infrastructure, since it mitigates the system requirements and potentially supports improved classical data rates for link lengths of up to 100 km.

Fig. 4 shows a potential future quantum-secured communication concept, which incorporates a space-air-ground-sea integrated network model that can achieve high-rate, reliable and secure connectivity across broad coverage ranges [62]. A number of aerial facilities, including low-Earth-orbit (LEO) and geostationary-Earth-orbit (GEO) satellites, planes and unmanned aerial vehicles (UAVs), ground stations and vehicles, as well as ships and underwater vehicles will be integrated. As a result of recent breakthroughs in nanotechnology, quantum systems have been reported to harness highly directional antennas in the THz, infrared, and optical bands [63]. As illustrated in Fig. 4, different propagation media, including optical fiber, THz, microwave and millimeter wave (mmWave), laser and visible light communication (VLC), X-band and Ku/Ka-band, L-band and C-band, will have to be critically appraised in support of seamless connectivity, reliability, and high throughput [49]. For example, optical fibers are extensively harnessed for connecting network entities in the core networks [64]. Lasers are used for connecting different satellites and individual satellites with ground stations [65]. Furthermore, the X-band, Ku/Ka-band, and THz bands have great potential in inter-satellite connections. The THz band has also been considered for providing local coverage on the ground [66]. These propagation media can potentially support quantum communications in the future.

In a nutshell, quantum communication provides a high level of security by harnessing quantum technology to detect eavesdropping attempts. QKD protocols rely on the statistical detection of eavesdropping and detect unauthorized tampering with the information, making quantum cryptography a compelling design option for secure data communication. Numerous QSDC protocols have been proposed for improving security, for example, by harnessing decoy photons and entangled states to prevent attacks. These protocols demonstrate the benefits of quantum technology in detecting and preventing eavesdropping, making it an ideal choice for secure communication.

D. High Sensitivity of Quantum Sensing

Quantum sensing can significantly increase the accuracy of traditional sensing and detection techniques [67]. This can play a critical role in future application scenarios, such as smart cities, smart industries, telemedicine, driverless cars, and other emerging technologies. Quantum sensors [68], which are based on continuous-variable (CV) systems [69], exploit the unique characteristics of quantum mechanics, including quantum entanglement [25], quantum coherence [26], and quantum state squeezing [27], to achieve high levels of precision. These properties of quantum mechanics have been specifically optimized for use in quantum sensors. The next generation of quantum sensors has the potential to surpass the capabilities of current sensor technology.

Quantum radars operate using entangled photons, which allows them to operate at extremely low power levels [70]. This makes them useful for a range of applications, including biomedical [71] and security applications [72], since they can effectively hide behind background noise as exemplified by the microwave-based system of [73]. This technology has the potential of creating stealthy radar systems that emit minimal detectable electromagnetic radiation.

The future network infrastructure is envisioned to be optimized for an integrated space, air, ground, and underwater network to ensure full global coverage and high-speed user mobility [11], [12]. All these aerial, terrestrial, and underwater network devices can have quantum-based clocks and are precisely synchronized to nanoseconds. Therefore, it can enhance communication capacity and sensing accuracy. Moreover, integrated sensing and communications (ISAC) [74], [75] will be a key differentiating technique of future systems in support of new applications, such as autonomous driving, intelligent industrialization, remote medical care, and holographic communications [76]. All these new applications require ultra-reliable communication and high-resolution sensing capabilities that cannot be fully satisfied by traditional communication and/or sensing techniques. With the development and realization of quantum technologies, accurate quantum sensing and high-speed quantum communications have the potential to contribute to the deep integration of the real physical and virtual digital worlds.

E. Emerging Quantum Use Cases and Standardization

On February 17, 2022, JPMorgan Chase announced the joint launch of a QKD network with Toshiba and the U.S. telecom system provider Ciena, demonstrating the full feasibility of a metropolitan QKD network for securing its payment network link in the face of steganographic attacks [100]. In 2019, researchers from Singapore's Nanyang Technological University reported in an article published in Nature Photonics [101] that the first millimeter-scale quantum communication chip was fabricated to provide outstanding quantum security with the aid of compact devices, e.g., smartphones, tablets, and smartwatches.

In 2007, the Defense Advanced Research Projects Agency (DARPA) initiated a research program to examine the benefits of optical quantum sensors [102]. These sensors aim

TABLE II
QUANTUM TECHNOLOGY FOR FUTURE COMMUNICATION VISION AND USE CASES [7]

Future communication vision	Scenario and use case	Corresponding quantum technology
Intelligent connectivity	Industrial robot, AI cameras, 4K UAV, bank/stock exchange, intelligent plant control	Quantum AI, quantum error correction, quantum cryptography, quantum machine learning (ML), etc.
Deep connectivity	Driverless vehicle, high-speed rail control, tactile Internet, deep data mining, industrial edge controller	Quantum AI, quantum error correction, quantum deep data mining, etc.
Holographic connectivity	Holographic communication, high fidelity VR/AR	Quantum dense access, quantum multiple access, quantum entanglement multiple access, quantum computing, etc.
Ubiquitous connectivity	Internet of Things (IoT), space-air-ground-sea integrated network	Entangled quantum, QKD, continuous-variable QKD (CVQKD), quantum metropolitan area network (QMAN), distributed quantum applications, etc.

to improve the accuracy of lidar and other optical sensors through techniques such as quantum lithography, as detailed in [102]. These sensors are expected to find applications, including in defense [67], navigation [103], and mapping of contour [104]. Quantum sensing is considered the most mature quantum technology for gas-sensing [105] and deep space exploration [106].

Quantum technologies have already found some future real-world use cases, such as the provision of ultimate communication security for smartphones, banking and the broader financial industry, sensitive data protection and defense, as well as holographic communication aided VR/AR [107]. A number of examples are provided in Fig. 2 and Tab. II, including bank/stock exchange, intelligent plant and smart grid control, high-speed rail control, and personal information security business.

Some other important use cases are authentication, digital signatures, and secure access control keys, which can all be generated by ID Quantique (IDQ) using its quantum random number generators (QRNG) [108]. As a benefit, the customer encryption keys and mission-critical data remain in the hands of customers despite third-party management of the banking networks. Credit cards can be encrypted with the aid of quantum communications and hence remain protected from fraudulent use [79].

As opposed to magnetic stripes or embedded computer chips, quantum-secured authentication uses nanoparticles attached to a credit card to create a unique pattern with the aid of a laser beam directed at the nanoparticles, which cannot be replicated. Even if the attacker obtained the encoding key, the sensitive information on the credit card would remain unusable [109]. IDQ provides long-term data protection from future quantum computer attacks as well, when large-scale quantum computers become available. Anecdotally, during the election process in Geneva, IDQ implemented an Ethernet encryption system with QKD as a pivotal component of ensuring the integrity and security of the voting process. Games and virtual conferences can be enhanced by holographic communication [110]. The randomness of online gaming must be ensured to secure a uniform winning probability. QRNG is used by several companies worldwide to generate highly

unpredictable, repeatable numbers.

To address the pre-standardization aspects of networked quantum information technology (QIT), the International Telecommunication Union's (ITU's) Telecommunication Standardization Sector formed a Focus Group on Quantum Information Technology for Networks (FG QIT4N) [111]. In November 2021, the group delivered nine technical reports to specify the general QIT terminologies [112], use cases [78], standardization outlook and technology maturity [113]. Furthermore, they also considered QKD networks [114] and their user cases [115], protocols [116], control and management [117], network transport technologies [118], and standardization prospects [119]. An evolutionary roadmap for quantum-empowered future systems is provided in Tab. III.

F. Contribution and Organization

This survey advocates the radical frontier research, quantum-by-design notion, where the potential synergy between quantum communications and future systems is discussed. The family of candidates quantum communication technologies, such as quantum multi-input multi-output (MIMO), quantum non-orthogonal multiple access (NOMA), QSDC/QSIC, quantum AI, quantum sensing and timing for future systems, are explored in the light of the relevant recent research breakthroughs.

The key contributions of the survey are as follows.

- We highlight a wide range of quantum technologies in line with the future communication vision and application scenarios. In contrast to existing surveys heavily focused on QKD, we also provide a broader perspective on QSDC and QSIC. (Sections I, II and VI)
- We explore a new perspective, namely for future high-frequency communication, where the particle effect is strong. Hence, the feasibility of quantum communications is improved. It is promising to exploit the wave-particle duality of quantum systems for improving the communication performance in future systems. (Section I)
- A new networking perspective is adopted for assessing the synergy between quantum techniques and different segments of future communication systems, including multi-band quantum access, quantum relays, quantum

TABLE III
STAGES OF QUANTUM-EMPOWERED COMMUNICATION SYSTEMS [77], [78].

Involved field	Key technologies	Near-term objectives	Long-term objectives
Quantum communication	<ul style="list-style-type: none"> • Quantum cryptography [52]; • QRNG [79]; • Quantum key distribution; • Photon detection technologies; • Quantum repeaters; • Quantum memory techniques [80]; • Quantum entanglement distribution devices; • Distributed quantum processors. 	<ul style="list-style-type: none"> • Advances in QKD, QRNG, and quantum-secure authentication systems [81]; • Develop trusted node network functionality [82]; • Develop global secret key distribution [83]; • Demonstrate a basic link as a building block for future quantum repeater; • Develop network performance, application, protocol, and software test suites. 	<ul style="list-style-type: none"> • Demonstrate a chain of quantum repeaters [84] at physical distances; • Demonstrate a quantum network node of at least 20 qubits connected to a quantum network; • Demonstrate device-independent-inspired QRNG and QKD; • Using satellite-based links to demonstrate entanglement generation [85];
Quantum computing	<ul style="list-style-type: none"> • Scalable quantum computing [86]; • Quantum error correction and fault-tolerant quantum computing [87]; • Quantum computing chip or device; • Quantum algorithm; • Classical networking enhancement for quantum computing; • Quantum networking interconnection of quantum computers [88]. 	<ul style="list-style-type: none"> • Demonstrate practical strategies for fault-tolerant universal quantum computer [89]; • Identify algorithms and use cases with quantum advantages; • Enhance the noisy intermediate-scale quantum (NISQ) processing mechanism with error mitigation [90]; • Initiate research in quantum device physics, qubits, and gate control; • Liaise with standards bodies. 	<ul style="list-style-type: none"> • Demonstrate quantum processors equipped with quantum error correction [91] and robust qubits with a general gate set; • Demonstrate quantum algorithms with quantum advantages; • Coordinate research, development and integration in quantum device physics, qubit and gate control, quantum memory; • Extended suite of quantum algorithms, such as digital error correction systems, optimization compilers [92] and libraries.
Quantum sensing	<ul style="list-style-type: none"> • Quantum clocks [93]; • Improved optical sensing and imaging; • New space-based time and frequency transfer techniques; • Improved single-photon detectors and arrays [94]; • Spin-based sensors and entanglement-based sensors [25]; • Quantum-enhanced radio frequency, microwave and optical signal processing and detection; 	<ul style="list-style-type: none"> • Laboratory demonstrations of engineering quantum states in real-world applications. • Develop prototypes of quantum-enhanced, super-resolved, and sub-shot noise microscopy, spectroscopy [95], interferometry, quantum lidar and radar [96]; • Develop chips that integrate photonics, electronics and atoms, miniaturized lasers; • Establish standardization, calibration, and traceability for new sensor technologies; 	<ul style="list-style-type: none"> • Integrate quantum measurement [97] standard for self-calibration of instrumentation; • Develop magnetometers for improved magnetic resonance imaging, high-performance optical clocks, and atomic interferometers [98]; • Develop quantum sensor networks as well as space-borne quantum-enhanced sensors, including optical clocks atomic and optical inertial sensors [99].

resource allocation, and quantum routing in support of future quantum-native systems. (Sections V and VI)

- We review quantum optimization algorithms and neural networks to explore the new research direction for the potential integration of quantum technologies and AI. (Section VII)
- We highlight the status quo of quantum sensing, quantum radar, and quantum timing, which are important research areas and can potentially extend the sensing capability for ISAC. (Section VIII)
- Research gaps and future directions are identified in each network segment of future systems in support of quantum-native design. In particular, (Section X)
 - The entanglement coherence time severely limits the effective generation and distribution of entangled qubits. Therefore, it is urgent to develop new technologies to extend the entanglement coherence time.
 - The design of THz quantum communications devices is in its infancy. Challenges, including noise suppression techniques, high-gain antennas, and accurate parameter estimation algorithms, are yet to be

addressed.

- The high mobility of quantum communication nodes, such as satellites and UAVs, can lead to rapid propagation channel fluctuations, leading to new challenges in channel estimation and tracking. The Doppler shift will also affect the measurement of quantum states.
- A joint design of quantum communication and quantum computing based on quantum superposition, entanglement, and coherence constitutes a critical step toward quantum-native designs. Yet, little to no effort has been documented in the open literature.
- Quantum error correction [120] will be critical in a potential joint design of quantum communications and computing. However, its technical maturity is low.
- The fundamental relationships, theoretical bounds, and performance trade-offs of quantum communication, quantum computing, and quantum sensing have to be established in support of quantum-native designs.

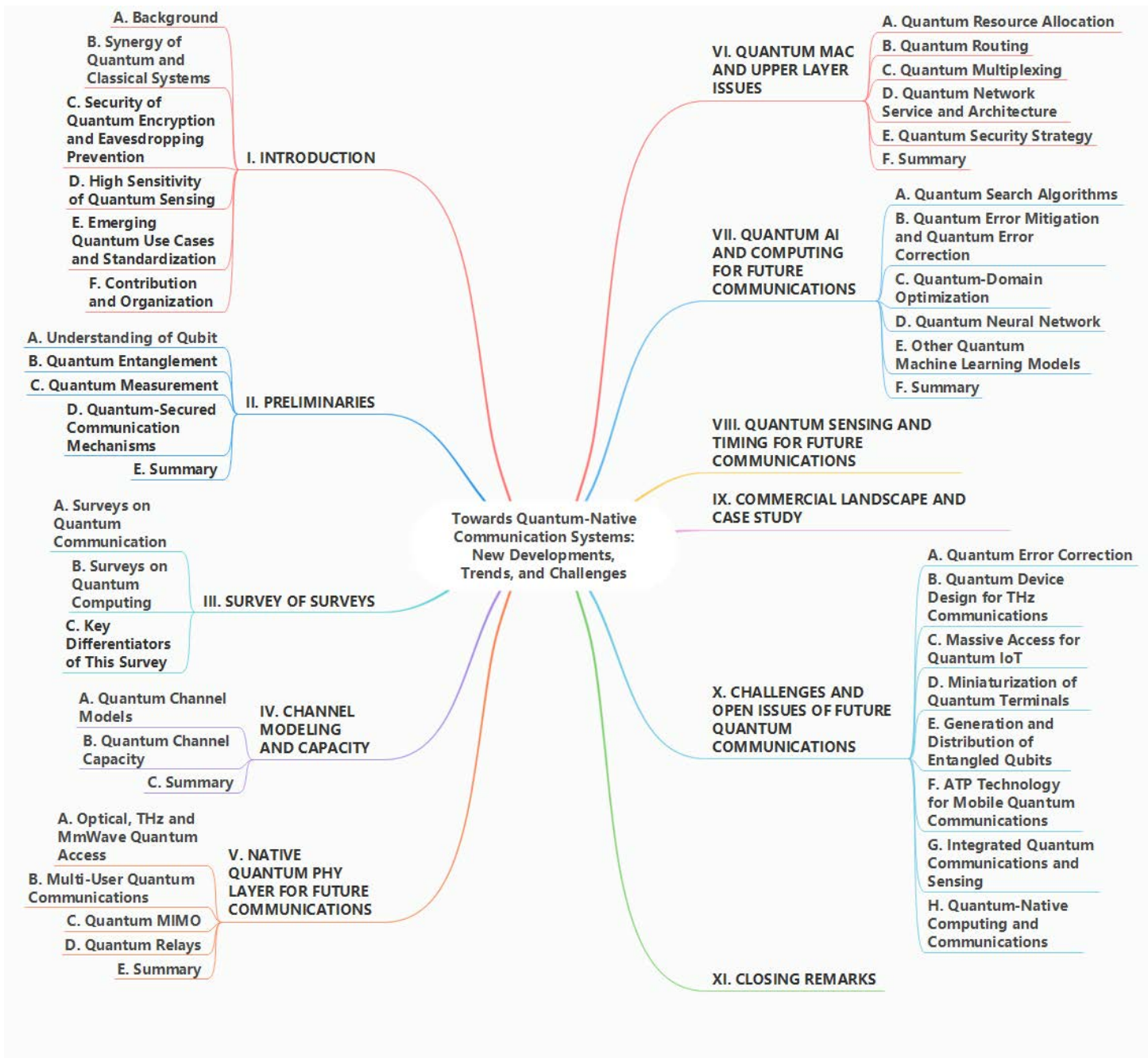

Fig. 5. The outline of this survey.

The rest of this survey is structured as depicted in Fig. 5. Section II introduces the fundamental concepts of quantum mechanics and quantum-secured communication schemes. Section III reviews the existing surveys on quantum communication and computing. In Section IV, we summarize the family of quantum channel models. Section V summarizes the latest research on quantum communication technologies, including some facets of multi-user, MIMO, and relaying techniques in the quantum context. Section VI analyzes resource allocation, routing protocols/algorithms, multiplexing techniques, and quantum-secured network service in the potential networking context. Quantum AI and computing are discussed in

Section VII. In Section VIII, quantum sensing and quantum timing are appraised in the potential context of next-generation (NG) applications. In Section XI, the commercialization efforts of quantum technologies are summarized, and the open challenges of future quantum-aided systems are discussed in Section X, followed by our concluding remarks in Section XI. Tab. I lists the acronyms and abbreviations used.

II. PRELIMINARIES

A quantum communication system uses the quantum states as the information carrier. The propagation of the quantum states in a quantum channel follows the law of quantum

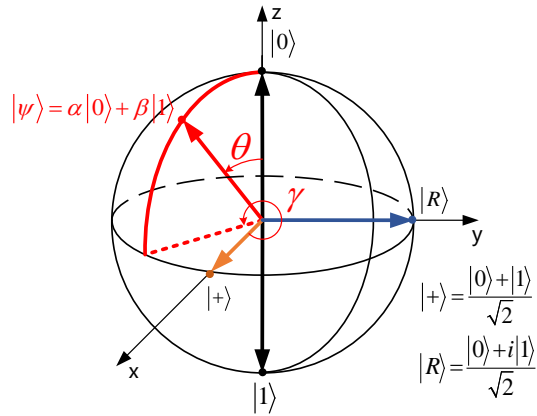

Fig. 6. Bloch sphere. Any point on the Bloch sphere represents a qubit, which can be represented by the angle parameters θ and γ . A qubit can be expressed as $|\psi\rangle = \alpha|0\rangle + \beta|1\rangle$, where $\alpha = \cos\frac{\theta}{2}$, and $\beta = e^{i\gamma}\sin\frac{\theta}{2}$ [130].

mechanics [121]. This section provides some rudimentary preliminaries on quantum mechanics, including the concepts of qubits, quantum entanglement, and quantum measurement. Three popular quantum communications techniques, namely, QKD, QSDC and QSIC, are briefly introduced and compared.

A. Understanding of Qubit

In classical communications, a classical bit is the basic unit of transmission and storage. Each bit can represent one of the binary symbols from the set $\{0, 1\}$. However, in the quantum communication field, information is represented by a qubit [30]. For example, the basis vectors in a two-dimensional Hilbert space are $|0\rangle$ and $|1\rangle$, where $|\cdot\rangle$ is the so-called ket operator derived from the word bra-ket. A qubit can be expressed as

$$|\psi\rangle = \alpha|0\rangle + \beta|1\rangle. \quad (1)$$

The qubit may be in the state $|0\rangle$, or in the state $|1\rangle$, or in the superposition state $\alpha|0\rangle + \beta|1\rangle$, where $\alpha = \cos\frac{\theta}{2}$, and $\beta = e^{i\gamma}\sin\frac{\theta}{2}$. Here, $i = \sqrt{-1}$. As shown in Fig. 6, any point on the Bloch sphere represents a qubit [130], which can be uniquely identified by the angle parameters θ and γ . As it transpires from this figure, there can be an infinite number of qubits on the Bloch sphere.

Using a so-called density operator constitutes an efficient method of describing the quantum system by a series of probabilistic superpositions based on their states [33], which is formulated as $\rho = \sum_j p_j |\psi_j\rangle \langle\psi_j|$, where $|\psi_j\rangle$ indicates a legitimate state of the system, and p_j represents the probability of the state. The density operator contains all the state information of a quantum system.

B. Quantum Entanglement

Schrödinger introduced the concept of quantum entanglement into quantum mechanics in 1935, which became a unique resource for quantum communications [131]. In the two-qubit composite system, $A \otimes B$, if the entangled state cannot be

expressed in the form of a direct so-called tensor product $|\psi\rangle_{AB} = |\psi\rangle_A \otimes |\psi\rangle_B$, the composite state is said to be a common two-qubit Bell entangled state. There are four Bell states, namely [33],

$$|\psi^+\rangle_{AB} = \frac{1}{\sqrt{2}} (|0\rangle_A |1\rangle_B + |1\rangle_A |0\rangle_B), \quad (2)$$

$$|\psi^-\rangle_{AB} = \frac{1}{\sqrt{2}} (|0\rangle_A |1\rangle_B - |1\rangle_A |0\rangle_B), \quad (3)$$

$$|\phi^+\rangle_{AB} = \frac{1}{\sqrt{2}} (|0\rangle_A |0\rangle_B + |1\rangle_A |1\rangle_B), \quad (4)$$

$$|\phi^-\rangle_{AB} = \frac{1}{\sqrt{2}} (|0\rangle_A |0\rangle_B - |1\rangle_A |1\rangle_B). \quad (5)$$

A specific property of the Bell state is that both A and B are uncertain before observing or synonymously measuring them. After the measurement of one of the states, the state of the other also becomes known. For example, for $|\phi^+\rangle_{AB}$, if the observed state of A is $|0\rangle$, then the state of B must be $|0\rangle$; and if the observed state of A is $|1\rangle$, then the state of B must be $|1\rangle$.

C. Quantum Measurement

Quantum measurement is a key concept in quantum mechanics, which is one of the salient operations in quantum communication and quantum computing. These techniques have no direct counterpart in classical systems. The receiver then observes the quantum states using a quantum measurement operator, selects the relevant observations from a finite set, and restores the classical information. This process is vital for the utilization of quantum technologies [132].

In quantum mechanics, the measurement of an arbitrary quantum state $|\psi\rangle$ in the Hilbert space \mathcal{H} is performed using a set of measurement operators $\{\Pi_m\}$. These operators must satisfy the completeness condition of $\sum_m \Pi_m^\dagger \Pi_m = I_{\mathcal{H}}$, where $(\cdot)^\dagger$ denotes conjugate transpose, and $I_{\mathcal{H}}$ is the identity operator in the Hilbert space. The index m denotes the measurement result obtained after the measurement of the quantum state $|\psi\rangle$ with the aid of the measurement operator Π_m . The probability of obtaining the specific result m is formulated as:

$$p(m) = \langle\psi|\Pi_m^\dagger \Pi_m|\psi\rangle, \quad (6)$$

which must satisfy the normalization condition $\sum_m p(m) = 1$ since all probabilities must sum to unity. After the measurement, the quantum state of the system collapses onto the state $\frac{\Pi_m|\psi\rangle}{\sqrt{\langle\psi|\Pi_m^\dagger \Pi_m|\psi\rangle}}$.

For measurements of non-orthogonal quantum states having known probability distributions, the positive operator-valued measure (POVM) technique of [133] may be used. Assuming that the quantum state is a pure state $|\psi\rangle$, having a density operator $\rho = |\psi\rangle \langle\psi|$, and the measurement operator is $\Pi_m = |\mu_m\rangle \langle\mu_m|$, the probability of correctly detecting this quantum state can be expressed as $P_c = \sum_m |\langle\mu_m|\psi\rangle|^2$, where $|\mu_m\rangle$ is a vector of measurement operator. This expression represents the probability of obtaining the correct measurement result m , given the quantum state $|\psi\rangle$ and the measurement operator Π_m . Some other measurements, such as the projective measurement of [134], is a special case of POVM measurement.

TABLE IV
A COMPARISON OF QSDC, QSIC AND QKD

	QSDC	QSIC	QKD
Information carrier	<ul style="list-style-type: none"> Quantum state [33] 	<ul style="list-style-type: none"> Einstein-Podolsky-Rosen (EPR) photons [122] 	<ul style="list-style-type: none"> Quantum state [38]
Basic principles	<ul style="list-style-type: none"> Based on the relevant principles of quantum mechanics and quantum properties [35]. 	<ul style="list-style-type: none"> Remote association of quantum entanglement pairs [123] 	<ul style="list-style-type: none"> Heisenberg uncertainty principle [124] and quantum no-cloning theorem [125].
Whether to generate a secret key	<ul style="list-style-type: none"> It does not need to generate a secret key and does not depend on the encryption and decryption algorithms [33]. 	<ul style="list-style-type: none"> Do not need to generate a secret key [33], [126]. 	<ul style="list-style-type: none"> Quantum key distribution is only used to generate and distribute secret keys without transmitting any actual messages [127].
Advantages	<ul style="list-style-type: none"> It can directly and safely transmit secret information in the quantum channel with the characteristics of simplicity, convenience and real-time. It has higher security requirements than quantum key distribution, which not only requires the discovery of eavesdropping but also guarantees the security of the data transmitted before the discovery of eavesdropping [56]. 	<ul style="list-style-type: none"> Quantum teleportation is the simplest form of quantum communication [128]. It does not transmit any matter or energy. 	<ul style="list-style-type: none"> The research on QKD is the earliest, the fastest, the most mature theory and has been applied in practice [129].
Shortcomings	<ul style="list-style-type: none"> It is not conducive to the implementation of eavesdropping detection, error correction, privacy amplification and other steps in the protocol process. 	<ul style="list-style-type: none"> Cannot be used on faster than optical communications. 	<ul style="list-style-type: none"> The trusted trunk security problem is encountered.
Transmission channel	<ul style="list-style-type: none"> Optical fiber, free space channel 	<ul style="list-style-type: none"> Optical fiber, free space channel 	<ul style="list-style-type: none"> Optical fiber, free space channel

D. Quantum-Secured Communication Mechanisms

The family of quantum-secured communications protocols includes QSDC [34], [35], QSIC [123], and QKD [38], [101]. In addition to these three forms of quantum communications, there are also other techniques, such as quantum secret sharing [135], quantum private key encryption [136], quantum public-key encryption [137], quantum authentication [138], and quantum signature [139] based regimes. The following briefly describes the predominant quantum communication techniques, i.e., QSDC, QSIC, and QKD. Tab. IV summarizes the basic features of QSDC, QSIC, and QKD.

1) *QSDC*: This technique allows for the direct transmission of a secret message from Alice to Bob without the need for classical ciphertext communication as an intermediary [33]. As shown in Fig. 7, Bob generates a sequence of qubits and sends them to Alice through a quantum channel. Alice selects a subset of these qubits (known as control qubits) at random for detecting potential eavesdropping, which is essentially based on estimating the QBER. Explicitly, if an eavesdropper observes a qubit, it collapses back into the CD. This causes a qubit error. After this, Alice sends the positions of the selected qubits, as well as the measurement basis used, and the measurement results to Bob through a classical channel. Bob

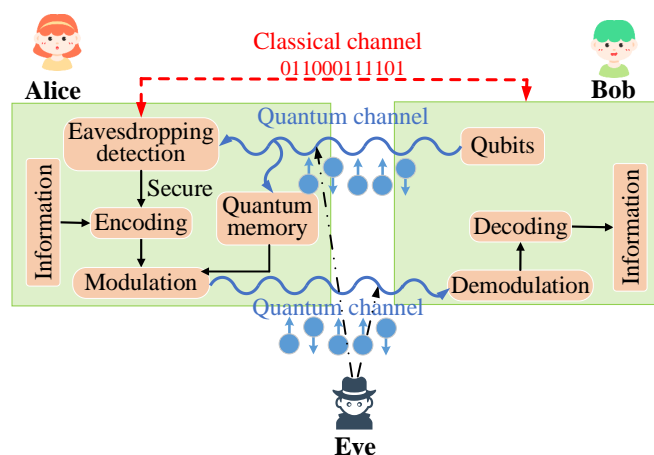

Fig. 7. Schematic diagram of QSDC. Bob prepares a sequence of qubits and sends it to Alice through the quantum channel. Alice randomly selects a sequence (control qubits) from the received sequence for eavesdropping detection. After that, Alice sends the selected sequence position, measurement basis and measurement results to Bob through the classical channel, and Bob performs security evaluation [33].

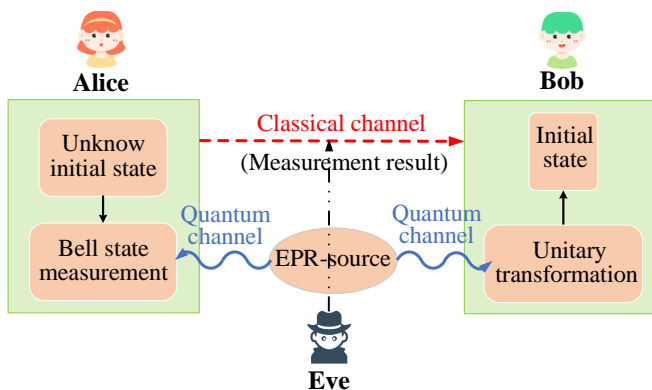

Fig. 8. Schematic diagram of QSDC. A pair of EPR photons are first distributed to Alice and Bob, and then Alice performs a joint Bell state measurement on the unknown initial quantum state to be transmitted with the EPR photons. Then Alice transmits the measured classical results to Bob through classical channels. Bob uses the EPR photon and the received classical information to perform the corresponding unitary transformation. Thus, Bob turns the EPR photon into the initial quantum state, which Alice wants to send [33].

then performs a security evaluation based on this information, again by estimating the QBER. After the evaluation, if the channel is considered safe without eavesdropping, Alice will encode the information sequence to be transmitted through the agreed encoding method, map it to the remaining qubits and send it to Bob through the quantum channel. Bob will obtain the information sequence after demodulation and decoding. As a benefit, QSDC does not have to generate any secret key, nor does it need any decryption algorithm, so even if there are eavesdroppers, it will not lead to information leakage [56].

2) *QSDC*: In contrast to other quantum-secured communication methods, QSDC does not have to transmit quantum states directly. Instead, it uses state entanglement to transmit information [33], [126]. A popular quantum-secured indirect communication technique is quantum teleportation [128]. The QSDC mode based on EPR photon pairs is shown in Fig. 8 [122]: a pair of EPR photons are first provided both for the transmitter Alice as well as for the receiver Bob. Then Alice applies joint Bell state measurement to the unknown initial quantum state (including the information encoded in the quantum state) to be transmitted with the aid of the EPR photons. Then Alice transmits the measured classical results to Bob through classical channels. Bob uses the EPR photon and the received classical information to perform the corresponding unitary transformation [140]. Thus, Bob turns the EPR photon into the initial quantum state that Alice wants to send. This method does not directly transmit quantum states but nonetheless completes the transmission of quantum states, so it is called quantum teleportation.

Another approach to QSDC is constituted by quantum dense coding [141], where the transmitter applies a unitary transformation to one of two entangled particles and then sends both particles to the receiver [141]. The receiver jointly measures the pair of particles and determines the type of transformation conducted by the transmitter based on the measurement results.

3) *QKD*: This is a specific key-negotiation protocol of quantum-secured communication relying on secret keys pro-

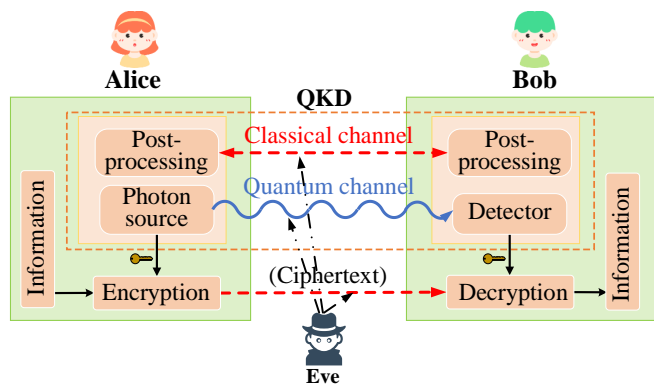

Fig. 9. Schematic diagram of QKD. The transmitter, Alice, uses the secret key allocated by the QKD system to encrypt the classical information sequence and sends it to the receiver, Bob, through the classical channel. After receiving the ciphertext, Bob decrypts it with his own key to get the classical information. The third-party eavesdropper Eve is unable to crack the ciphertext because it is impossible to obtain the secret key generated by the QKD system [33].

vided for both parties, which are then used for encrypting and transmitting data via a classical communication system. The QKD system is also capable of detecting the presence of an eavesdropper (Eve). It generates an absolutely secure quantum key, thanks to the no-cloning theorem, which implies that qubits cannot be copied because, upon observation, they fall back to the CD [63]. The basic structure of a QKD-based quantum-secured communication system is shown in Fig. 9. In this system, both the transmitter (Alice) and the receiver (Bob) have a classical secure communication system and a QKD system.

The QKD system generates and stores a key, and the system has two communication channels: a quantum channel for transmitting the photons used in QKD (assuming the use of optical quantum communication) and a classical channel for transmitting the encrypted data and auxiliary information generated during the QKD process, as detailed in [142]. Alice uses the secret key provided by the QKD system to encrypt a classical information sequence and send it to Bob via the classical channel. Upon receipt of the ciphertext, Bob uses his own key to decrypt it and retrieve the original classical information [127]. QKD-based quantum-secured communication has been the most rapidly developing practical quantum information technology to date [38], but in recent years QSDC has progressed even faster [143].

E. Summary

This section has touched upon the fundamentals of quantum communication, including qubits, quantum entanglement, and quantum measurement, as well as various quantum-secured communication protocols, such as QKD, QSDC, and QSDC. While much of the research has focused on QKD, this survey covers QKD, QSDC, and QSDC. We compare these methods and highlight the advantages of QSDC and QSDC. For example, QSDC allows for direct data communication without the need for key distribution, eliminating potential security vulnerabilities related to key storage and ciphertext

TABLE V
COMPARISON OF THIS SURVEY WITH OTHER RELATED SURVEYS, WHERE ✓ INDICATES THAT THE SURVEY HAS THE CORRESPONDING TOPICS, AND A
BLANK SPACE INDICATES OTHERWISE

Paper	Year	Quantum channels	Quantum physical (PHY)	Quantum media access control (MAC) and upper layer	Quantum AI and computing	Quantum sensing and timing	Commercial landscape
This survey		✓	✓	✓	✓	✓	✓
[144]	2023		✓	✓	✓		
[145]	2023		✓	✓			
[146]	2023					✓	
[147]	2023	✓	✓	✓			
[148]	2023		✓	✓	✓		
[149]	2023		✓	✓			✓
[150]	2023		✓	✓			
[151]	2023		✓	✓			
[152]	2022	✓					
[153]	2022		✓	✓			
[142]	2022	✓	✓	✓			
[154]	2022		✓	✓			
[155]	2022				✓		
[156]	2021		✓	✓			
[157]	2021		✓				
[158]	2021	✓	✓	✓	✓	✓	
[159]	2021				✓		
[160]	2020				✓		
[161]	2020				✓		
[162]	2020				✓		
[163]	2020		✓		✓	✓	
[79]	2020	✓	✓	✓			
[30]	2020	✓					
[164]	2019		✓	✓			
[165]	2019			✓			
[109]	2019				✓		
[24]	2019				✓		
[110]	2019		✓		✓		
[166]	2019	✓					
[21]	2019	✓	✓				
[167]	2018				✓		
[168]	2018		✓				
[129]	2018		✓				
[169]	2018	✓	✓	✓	✓		
[170]	2018	✓					
[38]	2018		✓				
[126]	2018		✓				
[31]	2018		✓				
[171]	2017				✓		

attacks [172]. Moreover, QSDC uses quantum mechanical principles to quantify the amount of data that an eavesdropper could potentially steal, offering unparalleled practical security [35]. Quantum teleportation, a type of QSIC, is a pivotal communication function in the proposed Qinternet. It allows for the “transmission” of qubits without physically transferring the particles that store them or without violating quantum mechanical principles [30].

III. SURVEY OF SURVEYS

The existing surveys on quantum information technology can be divided into quantum communication and quantum computing. The surveys typically focus on a limited number of aspects related to quantum communication networks, such as quantum key distribution, channel modeling, optimization algorithms, quantum circuits, and coding without a systematic, holistic picture of techniques and architectures of quantum-aided next-generation (NG) networks. By contrast, this survey endeavors to deliver a comprehensive perspective of the potential applications of quantum communication techniques for critically appraising their pros and cons in NG systems. Tab. V compared this survey against the existing surveys.

A. Surveys on Quantum Communication

There has been a significant focus on QKD in previous surveys of quantum communication due to the rapid advances [38], [79], [142], [164], [165]. Recent contributions have summarized practical QKD implementations and commercial QKD systems [21], [129], [154], [168]. For example, Zhang *et al.* [164] reviewed various branches of quantum cryptography, including QKD, quantum secret sharing, and QSDC. They also highlighted ongoing research in areas such as quantum-secured multi-party summation, quantum public key cryptosystems, quantum key agreement, quantum identity authentication, and other theoretical research topics. Sharma *et al.* [165] reviewed quantum public key encryption, QKD, and quantum authentication and provided a summary of QKD protocols. Zhang *et al.* [38] classified the salient experimental studies of global QKD into categories, such as the security level of QKD with imperfect devices, fiber-based QKD in metro networks, trusted relay-based backbone networks, and satellite-borne QKD in free space. Lai *et al.* [150] briefly reviewed the advances and trends in QKD research and the applications of QKD-based communications in China. Furthermore, they summarized the standardization of QKD and discussed the test and verification practices of quantum products and networks.

Cao *et al.* [142] provided an overview of QKD networks, including short-range, metropolitan, and long-haul networks from an engineering perspective. They described the architecture, components, interfaces, and protocols of QKD networks. They analyzed various enabling technologies, such as co-fiber transmission, relaying, satellite-borne and on-chip QKD at the physical layer. They also elaborated on key pooling, resource allocation, routing, cost minimization, and multi-user QKD at the network layer and the related standardization activities and application scenarios. Xu *et al.* [79] examined the

security risks of practical QKD, including the security proof and implementation of practical QKD, its vulnerabilities, and the latest progress of other quantum cryptographic protocols. They also addressed common concerns and considerations about QKD in practice, offering insights on how to overcome these issues while providing a long-term perspective on QKD. Pljonkin *et al.* [129] reviewed existing commercial QKD systems and discussed the development trends of QKD systems and quantum cryptographic protocols. Trinh *et al.* [168] reviewed the applications of QKD protocols in free space optical channels, with a focus on the associated system requirements in engineering design. They also discuss the potential integration of QKD and physical layer encryption in UAV deployments. Kong *et al.* [154] reviewed the use of QKD protocols in smart grids. Hosseinidehaj *et al.* [21] examined recent advances in CV quantum communication designed for LEO satellites, highlighting their potential to significantly improve confidentiality while paving the way for the global Qinternet. Casariego *et al.* [146] underlined the importance of handling both continuous and discrete variables in the context of microwave QKD. Furthermore, they highlighted the challenges in the field of quantum-domain microwave propagation.

There is a wealth of research on various aspects of quantum communication, including photonic quantum networks [126], optical fiber-based quantum communication systems [31], and quantum communication devices [157]. Flamini *et al.* [126] provided an overview of photonic quantum information technologies, summarizing the manipulation and detection techniques conceived for single-photon states. They also reviewed a whole suite of theoretical tools designed for simulating quantum communication, such as quantum repeaters and distributed blind quantum computing protocols conceived for photonic quantum networks, as well as long-distance QKD communication and photon quantum simulation. Pinto *et al.* [31] analyzed different quantum state encoding methods suitable for optical fiber quantum communication systems and discussed the realization of quantum protocols, including QKD, with a focus on quantum independent transport. Slattery *et al.* [157] reviewed quantum communication, quantum repeaters, and quantum communication devices available from the Information Technology Laboratory of the National Institute of Standards and Technology (NIST), and introduced metering tools and testbeds constructed for quantum networks.

There are several surveys that focus on different aspects of quantum communication, such as quantum channels [170], quantum teleportation [30], high-dimensional quantum communication [166], and the Qinternet [169]. For example, Gyongyosi *et al.* [170] provided an overview of quantum communication channels, including their characteristics, capacity metrics and practical implementations. A profound property of quantum communications has recently been revealed, namely that the channel’s capability of delivering information is also influenced by the superadditivity, superactivation and causal activation phenomena. In this context, Koudia *et al.* [152] offered valuable insights by presenting a comprehensive overview of the relevant literature from an insightful communication engineering perspective. Caccia-

puoti *et al.* [30] reviewed quantum teleportation processes, including the use of a communication system model for noiseless quantum teleportation and the defects of the model, such as decoherence caused by the environment. Cozzolino *et al.* [166] discussed the generation, propagation, and measurement of high-dimensional quantum states and the benefits of using high-dimensional quantum states in communication. They also presented existing experimental sources of qudits, which are multi-level computing units and offer larger state spaces for information storage and processing than qubits, for high-dimensional quantum communication experiments in different channels. Wehner *et al.* [169] presented a roadmap for a full-fledged Qinternet, and provided examples of known application protocols for each stage, along with the associated experimental and theoretical requirements. Botsinis *et al.* [109] devoted their efforts to highlighting the benefits of quantum search algorithms in the context of classical communication systems for solving a whole suite of optimization problems looking ahead to the era when large-scale quantum computing becomes available. For example, diverse multi-user detection [173], channel estimation [174], and transmit precoding [175] solutions were characterized in [109]. Singh *et al.* [158] provided a survey of research on the Qinternet, outlining its history and its functionalities, potential applications, enabling technologies, and open challenges. They discuss all the components of the Qinternet required for constructing a global quantum network. Jenet *et al.* [163] provided a comprehensive report on the standardization of quantum technology. The report introduces how standardization can support the deployment of quantum technologies in industrial applications, particularly in the areas of quantum security, confidential communications, measurement, sensing, and imaging. Standardization in these fields can ensure future interoperability and facilitate the integration of quantum technology into existing systems, as well as promote innovation and growth in the quantum industry.

Hasan *et al.* [147] surveyed the fundamentals of quantum communication, including its vision, design goals, information processing, and protocols. They also introduced a quantum communication system model and discussed a suite of prospective quantum technology applications beyond the existing technological landscape. In their contribution, Illiano *et al.* [153] focused their attention on the quantum Internet protocol stack. They emphasized the need for concerted efforts to design an efficient quantum Internet protocol stack. Rastogi *et al.* [156] provided an introduction to quantum communication, with an emphasis on polarization and entanglement, followed by a brief survey of its applications, including quantum teleportation, quantum key distribution, QSDC, and quantum memories. On the other hand, Ali *et al.* [148] highlighted the fundamentals of quantum computing and the evolution of quantum communication as well as its applications. They delved into the subject of quantum interconnects, quantum repeaters, and quantum security, offering insightful discussions on these topics. Their study also outlined the challenges that quantum-enabled 6G networks may face, complemented by potential future research ideas. In their treatise Paudel *et al.* [149] presented a comprehensive review of the latest

advancements in quantum networking and communications within the energy sector. Their focus encompassed platforms, devices, and protocols, including the popular topics of quantum teleportation and QKD. Furthermore, Purohit *et al.* [151] presented the current status of quantum technologies and emphasized the need for a quantum-ready ecosystem. Standard quantum technology readiness levels were formulated, and innovative models as well as tools were defined for assessing the readiness level of specific quantum technologies.

B. Surveys on Quantum Computing

Quantum computing relies on algorithms and circuits designed for quantum computers. Numerous researchers are working on developing quantum algorithms [161], [171] for a variety of applications, including quantum-aided classical communication systems [109]. For example, Li *et al.* [161] harnessed quantum algorithms for optimization and learning with the objective of improving the efficiency of traditional intelligent algorithms. Singh *et al.* [171] explored the evolution of quantum computing. Overall, the use of quantum algorithms and quantum computers has the potential to revolutionize a wide range of industries and applications.

Yang *et al.* [144] categorized and surveyed four crucial aspects of quantum computing: Quantum computers, quantum networks, quantum cryptography, and quantum machine learning. They conducted a comprehensive review of significant milestones as well as recent developments in quantum computing. They also highlighted the primary obstacles, major research directions, and emerging trends in these domains. On the other hand, Chawla *et al.* [145] offered a survey with an emphasis on the fundamental principles of quantum computing and assessed its implications for security in the Internet of Things (IoT). Their analysis encompassed diverse security aspects concerning smart IoT applications and explored quantum-based techniques for mitigating these challenges.

Huang *et al.* [155] provided a comprehensive overview of near-term quantum computing techniques, covering variational quantum algorithms surveyed in [188], [189], quantum error mitigation (QEM) [190], quantum circuit compilation [191], benchmarking protocols [192], and classical simulation [193]. These techniques hold great potential for advancing quantum computing in the near term, with practical applications in fields such as optimization, cryptography, and chemistry. However, challenges remain, and the authors identify areas where further research is needed, including developing more efficient algorithms, improved error mitigation techniques, and more robust hardware. By addressing these challenges, researchers can help pave the way for the development of practical and scalable quantum computing technologies that can benefit a wide range of fields.

A significant amount of research has focused on quantum computing [24] and quantum ML [110], [167]. Gyongyosi *et al.* [24] examined the basic hardware modules required for building quantum computers, the requirements for large-scale quantum computers, and the latest investigations on the physical implementation of quantum devices, computers, and algorithms. Nawaz *et al.* [110] provided a comprehensive

TABLE VI
A SUMMARY OF QUANTUM CHANNELS

Quantum channel	Feature	Application	Limitation	Reference	Remark
Depolarizing channel	<ul style="list-style-type: none"> Adapt to quantum systems with dimensions greater than 2. 	<ul style="list-style-type: none"> Simulate failures in quantum hardware, including qubit flipping and quantum gate errors resulting from quantum decoherence. Simulate the flipping of quantum states caused by actual transmission media, including wireless channels through free-space and optical fiber links. 	<ul style="list-style-type: none"> The classical capacity of the depolarizing channel is subject to the Holevo information of the channel. No quantum effect, e.g., entanglement, can be exploited to increase the transmission rate of the channel further. 	[176]–[179]	Free-space wireless channel & optical fiber link
Bosonic Gaussian channel	<ul style="list-style-type: none"> Arise whenever a harmonic system interacts linearly with a number of inaccessible Bosonic modes. 	<ul style="list-style-type: none"> The optical fiber quantum channel can be approximated as a Bosonic Gaussian channel for CV quantum information transmission. 	<ul style="list-style-type: none"> If the input is a Gaussian state, then the output state after passing through the channel is a Gaussian state. 	[180], [181]	optical fiber link
Free-space quantum channel	<ul style="list-style-type: none"> The performance of this system is heavily impacted by weather conditions, which tend to be variable and unstable. Factors such as fog, rain, wind, and atmospheric turbulence can all affect the system's performance. 	<ul style="list-style-type: none"> Potentially utilized in various communication situations where the received optical signal may be very weak, such as satellite-ground communication, deep-space communication, and underwater communication 	<ul style="list-style-type: none"> Susceptible to atmospheric effects such as absorption, aerosol scattering and turbulence. 	[182]–[187]	Free-space wireless channel

review of quantum computing and quantum ML in comparison to classical ML techniques. They also proposed a 6G communication framework based on quantum computing and quantum ML, discussing the challenges and promises of the associated network infrastructure. Dunjko *et al.* [167] outlined the basic concepts related to quantum data processing, ML, as well as AI, and explored the role of ML as well as AI in quantum physics.

Computationally intensive applications, such as ML, chemical simulations, and financial modeling, may be well-suited for noisy intermediate-scale quantum (NISQ) computers [159]. A major challenge in this context is the task of mapping quantum circuits onto NISQ hardware while also taking into account the physical constraints of the underlying quantum architecture. Li *et al.* [159] explored the challenges involved in this process through compelling examples and proposed quantum circuit compilation methods based on AI and heuristic methods for quantum circuit synthesis and mapping. They also evaluated the performance and potential limitations of different methods. Tiago *et al.* [194] reviewed the family of post-quantum public key encryption and digital signature schemes [195], as well as their applications in blockchain [196], followed by an overview of post-quantum cryptographic IoT systems designed for protecting IoT systems from known quantum computing attacks.

C. Key Differentiators of This Survey

The surveys discussed above have provided insights into a range of specific aspects, but they do not consider next-generation wireless systems. However, the employment of quantum technology in NG communications has the potential to revolutionize the way data is transmitted and processed. It may lead to significant advances in a variety of fields. Further study of these topics will be necessary to fully understand the potential of quantum technology and develop effective strategies for incorporating them into NG communication systems.

Hence, we examined how different quantum communication techniques can be applied at the different communication interfaces in the different layers of NG systems. For example, we summarize the latest research on multi-band quantum access [197]–[207], multi-user quantum communications [183], [208]–[212], quantum MIMO [44], [185], [213], quantum resource allocation [214]–[217], and quantum routing [218]. We also highlight the practical considerations of implementing these technologies in the real world. Overall, this review intends to offer a comprehensive overview of the potential of quantum communication technology in the context of NG communication systems and to identify areas for further research and development.

IV. CHANNEL MODELING AND CAPACITY

The study of quantum channel theory can provide the theoretical basis for the application of quantum information in communication and signal processing. In particular, the establishment of the mathematical models of the quantum channels is essential in deriving the capacities of quantum channels and can be distinctively different from that of classic channels. In this section, we exemplify several quantum channel models and discuss the quantum channel capacity.

A. Quantum Channel Models

Specific types of quantum channel models are listed below. Tab. VI summarizes the features of the depolarizing channel, Bosonic Gaussian channel, and free-space quantum channel.

1) *Depolarizing Channel*: Depolarizing channel includes three basic forms: bit-flip, phase-flip, and bit-phase-flip channels. The depolarization channel in the Hilbert space \mathcal{H} is characterized by:

$$\rho_{out} = \mathcal{N}_d(\rho_{in}) = \frac{pI_{\mathcal{H}}}{2} + (1-p)\rho_{in}, \quad (7)$$

where ρ_{out} and ρ_{in} represent the density operators of the output and input quantum state, respectively. Furthermore, \mathcal{N}_d refers to the channel's mapping action that transforms the input density operator to the output density operator in a depolarizing channel, where p is the depolarizing probability, while $I_{\mathcal{H}}$ is defined as

$$I_{\mathcal{H}} = \frac{1}{2}(\rho_{in} + \sigma_x \rho_{in} \sigma_x + \sigma_y \rho_{in} \sigma_y + \sigma_z \rho_{in} \sigma_z). \quad (8)$$

Here, σ_x , σ_y and σ_z are the Pauli matrices, denoted by $\sigma_x = \begin{pmatrix} 0 & 1 \\ 1 & 0 \end{pmatrix}$, $\sigma_y = \begin{pmatrix} 0 & -i \\ i & 0 \end{pmatrix}$, and $\sigma_z = \begin{pmatrix} 1 & 0 \\ 0 & -1 \end{pmatrix}$ representing the above-mentioned bit-flip, phase-flip as well as bit-plus-phase-flip actions.

2) *Bosonic Gaussian channel*: The Bosonic Gaussian channel is a widely used quantum channel. Holevo [219] established the expression characterizing it as:

$$\rho'_{out} = \mathcal{N}_b(\rho'_{in}) = \int_{\mathcal{N}_b} D(\xi) \rho'_{in} D^\dagger(\xi) p(\xi) d^2\xi. \quad (9)$$

Here, ρ'_{out} stands for the density operator of the output quantum state, \mathcal{N}_b denotes the channel's mapping action of the input density operator to the output density operator in Bosonic Gaussian channels, ξ is the complex amplitude, and ρ'_{in} is the density operator of the input quantum state, denoted as

$$\rho'_{in} = \frac{1}{\pi N_c} \int_{\mathcal{N}_b} e^{-\frac{|\psi|^2}{N_c}} |\psi\rangle \langle \psi| d^2\psi. \quad (10)$$

In (9), $D(\xi) = e^{\xi a^\dagger - \xi^* a}$ is the displacement operator, while ξ^* is the conjugate of ξ . Here, a^\dagger and a are the creation operator and annihilation operator of the input state $|\psi\rangle$, respectively. Still referring to (9), we have $p(\xi) = \frac{1}{\pi N_c} e^{-\frac{|\xi|^2}{N_c}}$ and N_c is the variance of channel noise (i.e. the average photon number).

3) *Free-space quantum channel*: In free-space quantum communication systems [21], atmospheric turbulence can affect the quantum states and can be modeled using various probability distributions, e.g., a log-normal, Gamma-Gamma, or negative exponential model. In physical terms, atmospheric turbulence is due to temperature and pressure fluctuations in ether. The Gamma-Gamma model is widely used to accurately describe turbulence, which has the following probability distribution [220]:

$$f(\eta) = \frac{2(uv)^{\frac{u+v}{2}}}{\Gamma(u) \cdot \Gamma(v)} \cdot \eta^{\frac{u+v}{2}-1} \cdot K_{u-v}(2\sqrt{uv\eta}), \quad (11)$$

where $K_{u-v}(\cdot)$ stands for the modified Bessel function of the second kind of order $u-v$, η stands for the intensity of the turbulence strength, $\Gamma(\cdot)$ denotes the Gamma function, while u and v are scintillation parameters, as defined in [220].

B. Quantum Channel Capacity

In contrast to classical channels, quantum channels have the ability to transmit not only classical information but quantum information as well. As a result, quantum channels possess both classical and quantum capacities. The classical capacity of a quantum channel represents the maximum amount of classical information that can be transmitted by the channel. It can be calculated by considering the upper bound on the amount of information accessible at the receiver through quantum measurement operators, as proposed by Holevo in [221], [222]. This upper bound is expressed as:

$$I(X; Y) \leq S(\rho_x) - \sum_k p_k S(\rho_k) = \chi, \quad (12)$$

where (12) is referred to as the Holevo bound, while χ is called the Holevo quantity. Furthermore, $I(X; Y)$ is the mutual information, X denotes the set of source information symbols at the transmitter, and Y denotes the measurement results at the receiver. Still referring to (12), ρ_k provides the density operator corresponding to the input quantum state with probability p_k , $1 \leq k \leq n$, while ρ_x gives the average density operator formulated as $\rho_x = \sum_k p_k \rho_k$.

The von Neumann entropy, denoted by $S(\rho_x)$, is a measure of information contained in a quantum state, as defined in quantum information theory [33] as:

$$S(\rho_x) = -\text{Tr}[\rho_x \log(\rho_x)], \quad (13)$$

where $\text{Tr}[\cdot]$ represents the trace operation.

In classical information theory, we assume that the source X sends classical messages x_ω ($\omega = 1, 2, \dots, \Omega$) with corresponding probabilities $p(x_\omega)$, and the classical Shannon entropy is expressed as $H(X) = -\sum_\omega p(x_\omega) \log p(x_\omega)$. Here, $S(\rho_x)$ can be expressed by the entropy of the probability distribution of the eigenvalues, i.e.,

$$S(\rho_x) = H(\{\lambda_\kappa\}) = -\sum_\kappa \lambda_\kappa \log(\lambda_\kappa), \quad (14)$$

where λ_κ are the eigenvalues of the density operator ρ_x .

In classical communication systems, the source entropy $H(X)$ is the bound of the mutual information $I(X; Y)$, hence

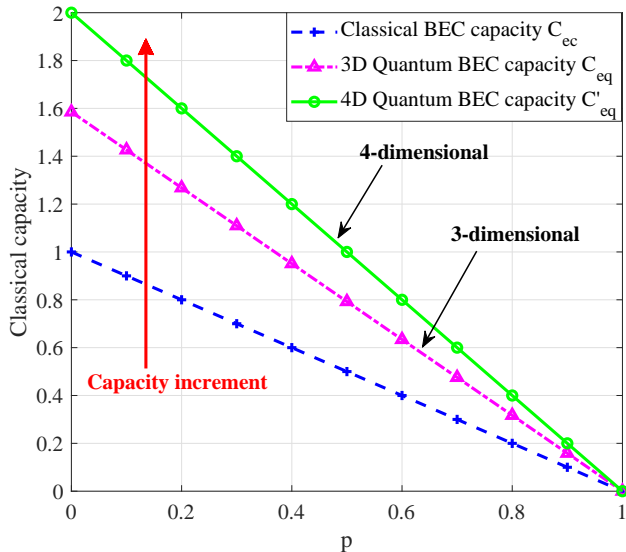

Fig. 10. Comparison of the classical BEC capacity and of the quantum BEC capacity vs. the erasure probability p . Compared to current classical communications, quantum communications have the powerful capability to transmit more information due to the increased Hilbert space dimension of the quantum channel [170].

$I(X; Y) \leq H(X)$. In quantum communication systems, the maximum amount of accessible information can be obtained when the states are orthogonal pure states, as visualized by the Bloch sphere of Fig. 6, and $\chi = H(X)$. For mixed states inside the Bloch sphere or non-orthogonal pure states, $\chi < H(X)$. Therefore, we have:

$$I(X; Y) \leq \chi \leq H(X). \quad (15)$$

In addition to the classical capacity, the quantum capacity of a quantum channel represents the maximum volume of quantum information that may be transmitted over the channel. This is measured by the maximum amount of quantum coherent information [223], denoted by C , which can be calculated using the following expression:

$$\begin{aligned} C &= \max I[\rho_x; \mathcal{N}(\rho_x)] \\ &= \max [S(\mathcal{N}(\rho_x)) - S(\rho_x; \mathcal{N}(\rho_x))], \end{aligned} \quad (16)$$

where $S(\cdot)$ stands for the von Neumann entropy, \mathcal{N} denotes the channel's mapping action of the input density operator to the output density operator gleaned from the channel, and $I[\rho_x; \mathcal{N}(\rho_x)]$ is the quantum coherent information.

Compared to classical communications, quantum communications have the potential to transmit more information due to the increased Hilbert space dimension d of the quantum channel [166], [170]. More explicitly, as shown in Fig. 10 through a specific example, the classical capacity of a quantum channel exceeds that of a classical channel, where C_{ec} is the classical binary erasure channel (BEC) capacity, C_{eq} is the classical capacity of a quantum BEC, p is the erasure probability, and d is the dimension of the input quantum system [170], [224]. Explicitly, we have $C_{ec} = 1 - p$, and $C_{eq} = (1 - p) \log d$. The classical channel can be viewed as a special case of the quantum channel associated with

$d = 2$. Indeed, it is plausible that a quantum superposition state, which is the linear combination of different quantum states, can help the quantum channel transmit more classical information bits than the classical channel [170].

In the d -dimensional Hilbert space, there are at most d pairwise distinguishable quantum states [170]. The options of increasing the number of photonic degrees of freedom have been reviewed in [166] with the objective of generating high-dimensional quantum states. In this context, the authors of [166] discussed the representation of quantum information in the increased Hilbert spaces of high-dimensional quantum systems relying on qudits [166]. Briefly, a qudit is a quantum system that is not constrained to a 2D space. In principle, it can have any integer number d of levels. A physical embodiment of d -dimensional systems is constituted by a photon. The authors of [166] also pointed out that different numbers of photonic degrees of freedom or their combinations can help expand the Hilbert space. For example, the OAM of light is one of the most frequently exploited photonic properties harnessed for generating high-dimensional quantum states. An arbitrarily large Hilbert space can be created since the number of dimensions can be any positive integer.

C. Summary

Channel modeling is indispensable for wireless communication system design and performance evaluation, as well as for network planning and deployment. This section has introduced several basic quantum channel models and discussed the capacity of quantum channels. Nevertheless, significantly more efforts have to be invested into developing versatile channel models for all quantum communication channels, such as THz and visible light quantum channels, as well as ISAC quantum channels.

V. NATIVE QUANTUM PHY LAYER FOR FUTURE COMMUNICATIONS

This section reviews a suite of technologies that might find their way into NG quantum-enabled PHY layers, such as multi-band quantum access, multi-user quantum communications, quantum MIMO, and quantum relays. We extend the point-to-point quantum communications philosophy to multipoint-to-multipoint scenarios that are suitable for ultra-dense NG scenarios.

A. Optical, THz and MmWave Quantum Access

In high-frequency spectra, including both optical and THz band, as well as mmWave band, quantum phenomena have been observed in [198], [207], [262]. The carrier frequency of THz waves is between that of mmWaves and infrared light waves, and they have attracted attention as a benefit of their abundance of bandwidth [263]. More explicitly, one of the promising NG technologies, the THz transmission, has a high capacity, high directionality and beneficial noise immunity [204]. Hence, it is worth exploring in support of quantum communication [206]. Studies on mmWave and THz quantum communication typically focus on the distribution of

TABLE VII
A SUMMARY OF CORRESPONDING RESEARCH ON MULTI-BAND ACCESS TECHNOLOGIES IN QUANTUM COMMUNICATIONS

	Wireless	Wireless-fiber hybrid	Material and Tx/Rx manufacturing
Optical frequency band	<ul style="list-style-type: none"> • Quantum key distribution: [187], [197]–[200] • Tracking system in wireless quantum communication networks: [201] • Multiple-quantum-well photodetector: [225], [226] 	<ul style="list-style-type: none"> • Quantum (shot) noise: [227] 	<ul style="list-style-type: none"> • The focal patterns of hyperbolic-cosine-Gaussian beam: [228]
THz band	<ul style="list-style-type: none"> • Quantum secret sharing: [202] • Quantum key distribution: [203]–[206] 	<ul style="list-style-type: none"> • Quantum-dash laser diode: [229] 	<ul style="list-style-type: none"> • Waveguide: [230] • Quantum cascade laser (QCL): [231]–[236] • Photodetectors: [237]–[244] • Other techniques: [245]–[252]
MmWave band	<ul style="list-style-type: none"> • Distribution of quantum entanglement over communication channels: [207] • Quantum-dash laser source: [253], [254] • Single flux quantum superconducting digital technology: [255] • Quasi-tunable millimeter-wave frequency synthesizer: [256] 	<ul style="list-style-type: none"> • Beamformer: [257] • Quantum-dash laser diode: [229] • Quantum-dash laser comb source: [258], [259] • Quantum dot coherent comb laser: [260] 	<ul style="list-style-type: none"> • Injection-locked quantum-dash laser: [261]

quantum keys in indoor environments and satellite-to-satellite wireless communications. The research of new materials in support of THz communications is also an active subject area [264], [265]. Tab. VII summarizes multi-band access technologies conceived for quantum communications.

1) **Optical Quantum Access:** Researchers are exploring the potential of the optical frequency band to exploit quantum phenomena and the potential techniques relying on it. The existing QKD systems typically use photons to transmit information through optical fiber or free-space optical (FSO) channels [204]. Compared to optical fiber, the FSO links are more hostile, but they are capable of distributing quantum keys worldwide [198]. QKD is commercially available at the time of writing [142], but given the lack of global standards, it is important to conceive QKD protocol converters for long-distance relaying across heterogeneous QKD networks [266]. The QKD field is hence further cultivated by various groups. For example, Pirandola *et al.* [197] and Zhao *et al.* [198] studied the fundamental ingredients of CVQKD systems and characterized QKD over free-space optical links in different scenarios. Sea salt particles in the atmosphere have also been used for CVQKD in [199]. The feasibility of QKD is also being investigated in short-range wireless quantum communication networks [201].

In addition to QKD, researchers are also exploring other applications of the optical frequency band, such as tracking systems [201] and multiple-quantum-well-based photodetectors [225], [226]. Alkhazragi *et al.* [225] achieved a record data speed of 7.4-Gbits/s using a selective-wavelength semi-polar InGaN/GaN-based multiple-quantum-well micro-photodetector in visible light communication. In [226], the fabrication of a multi-functional ultraviolet-C micro-LED having a monolithically integrated photodetector was characterized. Tanizawa *et al.* [227] conceived a technique for securing

both optical and microwave signals directly in the PHY layer. Finally, the tunable focusing properties of wireless and fiber-optic communications based on hyperbolic cosine Gaussian beams modulated by spiral optical vortices were analyzed in [228].

2) **THz Quantum Access:** Song *et al.* [263] reviewed the field of THz quantum communications, focusing on channel modeling, front-end devices, and prototyping to test the feasibility of THz communications. The concept of short-range quantum communication at THz frequencies was discussed in [205]. In contrast to pure optical quantum communication, such a THz-based scenario will allow for the direct integration of quantum communication into emerging wireless networks without complex optical-microwave interfaces [207]. Furthermore, THz frequency bands have the advantage of less delicate pointing, acquisition and tracking than optical bands. They are also less affected by ambient light, atmospheric turbulence, scintillation, clouds, and dust [267], [268]. More importantly, a non-zero secret key rate can be achieved at room temperature as a benefit of the relatively low thermal noise at THz frequencies [205], [269]. Pioneering studies have been conducted in THz communications, including QKD, quantum optimization algorithms, and satellite-to-satellite quantum communication systems. Liu *et al.* [202] developed a satellite-to-satellite communication system that involved CV quantum secret sharing [270]. They also proposed the use of multi-carrier multiplexing techniques for the distribution of CV quantum keys in the THz bands [204]. He *et al.* [203] demonstrated that hybrid linear amplifier-based detection of a thermal state-based CVQKD scheme operating in both the near- and mid-infrared bands, as well as in the THz bands is capable of improving the security. In [205], a promising physical hardware architecture was designed for implementing a QKD system in the THz band. Furthermore, the authors of [205]

provided a specific example of implementing such a system. A feasibility study of LEO-based quantum communications between micro-satellites relying on THz links was carried out in [206]. Mallick *et al.* [229] described the application of an OFDM-based 5G fronthaul in both the THz and the mmWave band. The THz and mmWave signals were generated with the assistance of L and C band quantum dash laser diodes.

The research community of materials and manufacturing processes invented for THz devices used in quantum-related applications - such as waveguides, quantum cascade lasers (QCLs), and photodetectors - has also made significant progress in recent years [230], [271]–[273]. QCLs constitute a crucial component of nanotechnology and have compelling applications in the THz and mid-infrared bands in the context of free-space communication [231]. The use of quantum-compatible materials has also been studied at THz, millimeter wave, and other radio frequencies [232]–[236]. These papers studied sophisticated modulation and manipulation methods, such as chiral metamaterial arrays designed for modulating QCL polarization [234], harmonic injection and mode-locking for modulating round-trip frequencies [235], and scanning near-field optical microscopy designed for the simultaneous measurement of the associated transport and scattering properties [236].

Photodetectors constitute another crucial component of quantum communication systems and have become a rapidly evolving research area during the past few decades [237]–[244]. Sophisticated techniques have been developed for uncooled THz photodetectors, such as quantum dot single-electron transistor-based photodetectors [238], quantum-dot nanowirenanodetectors [240], and sub-THz photodiodes [239]. Recent studies have analyzed popular implementations of THz quantum-well photodetectors designed for high-speed detection, imaging, and communications [243].

Resonators have also been conceived for modulating and decelerating THz light [274]. Additionally, the manipulation of OAM particles and high-capacity data transmission operations using vortex beams has been explored in [245]. More specifically, the authors of [245] have described techniques designed for generating OAM patterns that can be controlled by polarization [245]. The popular QD composite pulse control technique has been harnessed for the design of a THz half-wave plate by relying on multi-layered metamaterials [246].

3) **MmWave Quantum Access:** Generally, optical frequencies have been preferred for the implementation of quantum communication protocols, such as quantum teleportation and QKD [168], [278]. This is partly due to their low background black-body radiation [207]. As a further advance, the feasibility of direct QKD in the mmWave regime was also considered [279] with the ambitious objective of supporting quantum entanglement [207] without any need for integrating additional optical hardware into the transceiver.

To elaborate a little further, the research community has made significant progress in quantum entanglement distribution [207], quantum-dash laser sources [253], [254], single flux quantum superconductors [255], and quasi-tunable mmWave frequency synthesizers [256]. In this context, Hosseinidehaj *et al.* [207] analyzed quantum entanglement distribution for

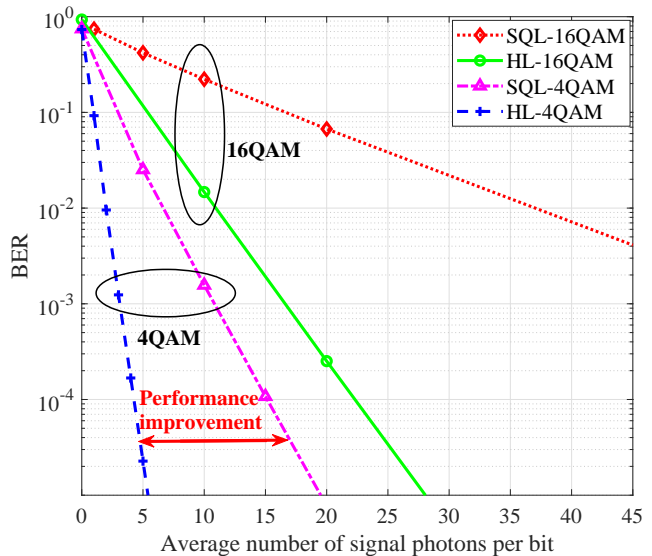

Fig. 11. Comparison of SQL [280] and HL [281]. HL of quantum systems represents better error probability than the SQL of classical systems. Hence, the quantum systems approaching the HL can potentially support new NG applications [282].

transmission over communication channels in the mmWave regime and quantified the expected communication transmission requirements. In [253], a wireless quadrature phase shift keying (QPSK) transmission scheme relying on quantum-dash lasers operating in the 28 GHz mmWave was examined. As a further development, an L-band quantum-dash laser suitable for mmWave signals was presented in [254]. A programmable Josephson-junction-based reference source covering the entire radio frequency spectrum spanning from 20 to 300 GHz was reported in [255]. Liu *et al.* [256] proposed a low-cost tunable ultra-wideband electro-optic frequency comb-based mmWave synthesizer. They used a quasi-tunable frequency in their experiments to generate mmWave signals.

Constructing a quantum fronthaul and backhaul at mmWave frequency requires significant receiver improvements, which might become feasible with phased arrays with narrow beam widths. A zero-energy integrated circuit was designed in [257] for a self-steering beamformer relying on four antenna elements. The authors of [257] also demonstrated that a concatenated fiber-wireless QPSK transmission system relying on a dual-wavelength InAs/InP quantum-dash laser source is capable of transmitting 28 and 30 GHz millimeter wave signals. Furthermore, they developed a quantum dot-based comb laser that supports the convergence of optical and wireless wavelength division multiplexing (WDM) techniques in the access network [258]–[260]. Tareq *et al.* [261] reported the establishment of a 2 Gbps QPSK wireless transmission system using a 28 GHz millimeter wave carrier relying on a so-called injection-locked quantum-dash technique.

4) **Other Technical Enhancements:** In order to harmonize the heterogeneous frequency bands and technologies of the electromagnetic waves and the particle-oriented photonic carriers, Xu *et al.* [283] introduced a Petahertz (PHz) communi-

TABLE VIII
A SUMMARY OF QUANTUM MULTIPLE ACCESS

Multiple access type	Scene	Examples	Short description
OMA	Quantum OFDMA	[208] , [209]	An alternative active setup for OFDM decoding; Subcarrier multiplexing technique with OFDM-QKD system
	Quantum TDMA	[211], [275]	On fair secure rate maximization; Passive star QKD networks using TDMA
NOMA	Quantum CDMA	[275]–[277]	Passive star QKD networks based on CDMA; A novel quantum CDMA technique that involves the spectrally encoding and decoding of continuous-mode quantum light pulses; CDMA-based QKD links with a single photon
	Quantum IDMA	[183], [212]	IDMA-QKD system over a Poisson atmospheric channel; quantum space coupling NOMA scheme

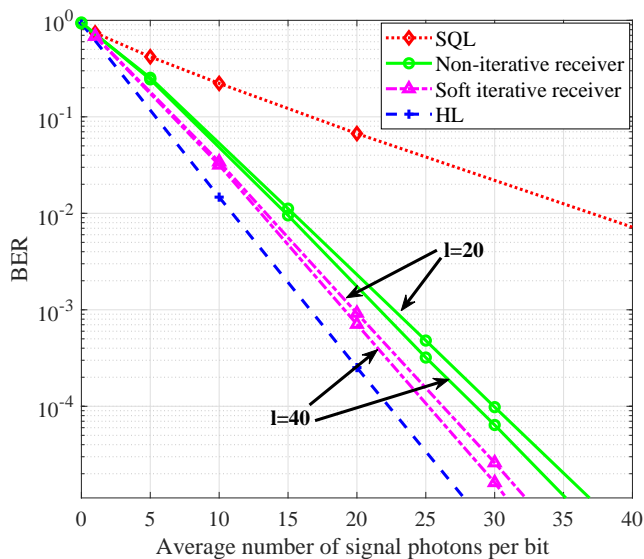

Fig. 12. Comparison of the error probabilities of the soft iterative receiver and non-iterative receiver for 16QAM. The soft iterative receiver achieves a significant performance improvement over its non-iterative counterpart and is close to the HL [282].

communication framework for wireless communication. Explicitly, the authors of [283] unified the existing infrared, visible light, and ultraviolet subbands and explored the potential of the PHz band for extremely bandwidth-thirsty applications. Furthermore, they discussed scenario-dependent channel models, modulation schemes, the expected system performance, as well as a suite of multiple access and networking techniques. The Helstrom limit (HL) [281] represents the ultimate error probability limit of quantum communication systems, which can be approached by using optimal measurement strategies and advanced devices. The quantum systems approaching the HL have to exhibit ultra-high receiver sensitivity. Hence, approaching the HL in practice is challenging. Fig. 11 compares the HL of quantum receivers to the standard quantum limit (SQL) [280] of classical receivers. Observe that the HL shows about three orders of magnitude bit error rate (BER) improvement over the SQL at five signal photons/bit for a 4QAM scheme. Wei *et al.* [282] developed an advanced method

for distinguishing QD signals with the radical objective of approaching the performance of the HL [281]. Their method utilizes beam splitters and iterative receiver techniques. As a benefit, it outperforms its non-iterative counterpart at the cost of an increased receiver complexity [284], [285]. Specifically, the received 16QAM QD signals are divided into l identical quantum states by $(l - 1)$ beam splitters. In the iterative quantum state observation process of the receiver, the optimal measurement operator and the decoding results are updated to gradually improve the soft log-likelihood ratio (LLR) of each information bit. The results of Fig. 12 show that, when $l = 40$ iterations are used, the proposed 16QAM soft iterative receiver achieves a significant performance improvement over its non-iterative counterpart and approaches the HL. In fact, the iterative quantum receiver exhibits an excellent performance even for fewer iterative measurement steps (say when $l = 20$). In [35], [286], polarization states [35] and polarization entanglement of photons [286] are utilized to create QSDC schemes. By contrast, the authors of [282] focus their attention on CV Gaussian coherent states and, therefore, enjoy the benefit of high information capacity, high signal strength, flexible high-order modulation, and convenient implementation. Moreover, the employment of CV Gaussian coherent states provides inherent compatibility with existing classical optical communication networks because CV systems can be readily implemented with the aid of off-the-shelf lasers and homodyne or heterodyne detectors [21]. Nevertheless, the CV Gaussian coherent states discussed in [282] can be incorporated into the QSDC schemes developed in [35], [286] to bring the above benefits into the QSDC system.

Sharma *et al.* [178] investigated the behavior of entangled states under various noise influences and observed the sudden disappearance and reappearance of entanglement in the presence of specific noise types and parameter values. Harraz *et al.* [287], [288] proposed advanced techniques for protecting two-qubit states from amplitude damping to ensure high-accuracy restoration of the original states. This method can be used for any mixed/entangled state, and it is robust to significant amounts of noise. Rahman *et al.* [289] explored the impact of channel impairments on the similarity between the initial and final quantum states, while the authors of [290] compared different channels in the context of single qubit mes-

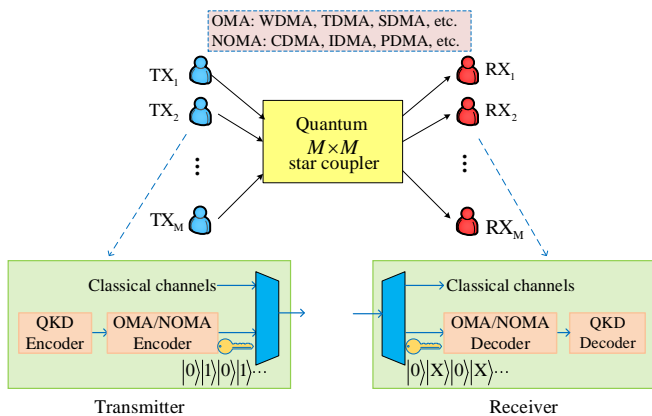

Fig. 13. Quantum-domain multiple access systems, including WDMA, TDMA, CDMA, IDMA, etc. All of the quantum users can be connected to each other via a quantum star coupler, which is modeled as a sequence of beam splitters that broadcasts all transmitters' QD signals to all receivers [275].

sage transmission and identified amplitude damping as well as depolarization noise as the main impairments [290]. The authors of [291] evaluated different communication systems in the face of white quantum noise and related their quantum-domain metrics - such as the conveyed number of bits per photon pair - to conventional measures like spectral efficiency and error correction performance. The results indicated a capacity of approximately 20 bits per photon pair (10 bits per photon) for Shannon's capacity, while single photon transmission per channel only reached 3 bits per photon pair. Chitambar *et al.* [179] provided a mathematical expression for both the family of Werner-Holevo channels defined in [292], [293] and for arbitrary qubit channels. They also revealed substantial differences in terms of the channel's ability to establish and sustain entanglement. These differences also manifested themselves in terms of the probability of successfully transmitting a randomly selected classical message over the channel.

B. Multi-User Quantum Communications

In recent years, there has been a rise in the adoption of point-to-point quantum communication systems due to their increasing commercial variability [142]. The next milestone will be the conception of multi-user quantum communication to provide quantum-secured communications over NG systems, as shown in Fig. 13. A diverse range of QD multiple access methods has been proposed (as shown in Tab. VIII), including quantum TDMA [211], [275], quantum OFDMA [208], [209], quantum code division multiple access (CDMA) [275]–[277], and quantum interleave division multiple access (IDMA) [183], [212].

1) **Quantum TDMA**: In TDMA systems, each user communicates with the base station in different time slots. Yang *et al.* [211] aimed to achieve max-min fairness in the downlink of a single-cell QKD system, where a base station supported the communication of several users in the presence of a single eavesdropper. They proposed combining TDMA QKD with the NOMA philosophy in order to increase the system's throughput without jeopardizing its security. A secret key was first generated and negotiated between the base station and

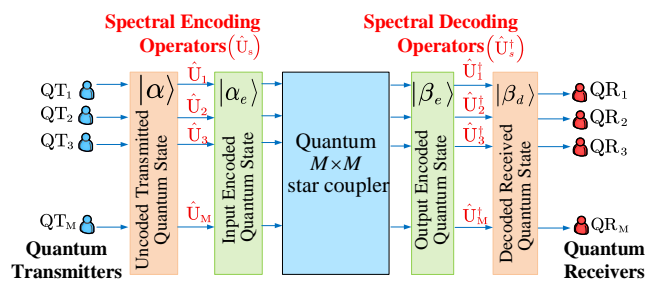

Fig. 14. Quantum CDMA. Each transmitter sends a pure quantum state, e.g., a coherent state or a Fock state, through a quantum CDMA spectral encoding unit \hat{U}_e . The star coupler broadcasts each transmitter's spectrally encoded QD signal to all the receivers. The quantum receiver, modeled by an ideal photodetector, performs the decoding operation through the spectral decoding unit \hat{U}_s^\dagger to recover the original quantum state [276].

users as part of the QKD protocol, followed by NOMA-based CD data transmission. They also proposed an iterative method for solving the resultant non-convex max-min problem that maximizes the minimal secure rate in the set of all users. Razavi *et al.* [275] proposed a multi-user QKD network that allows any pair of users to exchange a secret key without having to trust any other nodes in the network. To do this, they considered a passive star-topology QKD network in which TDMA was used to enable multi-access among quantum users, as shown in Fig. 13. In such a network, all users can securely communicate with each other by relying on TDMA QKD, enabling them to distinguish between different users' QD signals. Their simulation results demonstrated that TDMA QKD is capable of secure communication in multi-user environments.

2) **Quantum OFDMA**: OFDMA maps multi-user data streams to different time- and frequency-domain resource slots. Its core physical-layer element is OFDM, which is capable of combatting the inter-symbol interference imposed by dispersive channels and has been standardized for both the classical 4G and 5G systems. QKD may indeed be integrated with OFDM if an all-optical OFDM transmitter and receiver pair are used in quantum communication channels. In this context Bahrani *et al.* [208] characterized QKD over all-optical OFDM links. The QKD encoder generates QD signals in the form of pulses that carry information about the encoded key bits in each subchannel. The resultant optical pulses are simultaneously mapped to the OFDM subcarriers. A pair of OFDM-QKD schemes were considered in [208] for quantum-secured communication in the face of realistic system imperfections. One of the transmitter designs was based on frequency-offset-locked lasers, while the other utilized a mode-locked laser relying on an optical splitter. Anandan *et al.* [209] proposed OFDM for improving the key rate vs. secure link length of a QKD system.

3) **Quantum CDMA**: In addition to the above-mentioned quantum TDMA system, Razavi [275] also presented a CDMA-based multi-user star-topology-based QKD network that is capable of mitigating the interference effects. They also found the average lower bounds of the secret key generation rates when decoy-state protocols were used. As shown in

Fig. 13, all of the quantum users are connected to each other via a QD star coupler, which can be modeled as a sequence of beam splitters that broadcast all transmitters' QD signals to all receivers. The transmitter includes a QKD encoder and a CDMA transmitter for supporting the access of multiple quantum users. The CD and QD signals are assigned two different bands and combined by a band multiplexer. The receiver includes a band demultiplexer, which separates the quantum and the classical channels, and a CDMA receiver, followed by the necessary QKD measurements. Rezai *et al.* [276] proposed a new quantum CDMA technique based on continuous-mode quantum light pulse spectral encoding and decoding, as depicted in Fig. 14. Observe that in quantum CDMA, each transmitter sends a pure quantum state, e.g., a coherent state or a Fock state, through a quantum CDMA spectral encoding unit \hat{U} . The star coupler broadcasts each transmitter's spectrally encoded QD signal to all the receivers. The quantum receiver, modeled by an ideal photodetector, carries out detection within the spectral decoding unit \hat{U}^\dagger to recover the original quantum state. As a further advance, Sharma and Banerjee [277] considered a single optical fiber as a transmission channel and studied spread spectrum techniques in which multiple users transmitted their qubits. They improved the performance of CDMA-based QKD links relying on single photons without any amplifiers and modulators. They also used receiver filters for mitigating the spectral overlaps, thereby improving the signal-to-noise ratio (SNR).

4) **Quantum IDMA**: IDMA inherits many of the benefits of CDMA, which may be viewed as a chip-interleaved CDMA system, where the users are distinguished by their unique, user-specific interleavers. An iterative IDMA-based NOMA-QKD multi-user system operating in the presence of Poisson shot noise was proposed for FSO communication in [183], which is depicted in Fig. 15. To support multi-user information transmission, their quantum transmitter was designed to support NOMA. The authors considered atmospheric turbulence channels and a single-photon FSO detector. More explicitly, as shown in Fig. 15(a), the IDMA-based iterative multi-user NOMA-QKD system harnesses an iterative detector that detects photons exhibiting different polarization states, once the quantum measurement was completed. The *a-priori* and *a-posteriori* LLRs were processed iteratively using a sophisticated multi-user detection method, see Fig. 15(b). The simulation results of [183] confirmed that despite the presence of atmospheric turbulence and polarization mismatch noise, the proposed IDMA multi-user NOMA-QKD scheme exhibited rapid convergence and robust performance. As a system-level benefit, it significantly improved the secure key rate compared to traditional wavelength division multiple access (WDMA) based QKD systems. Shen *et al.* [212] proposed a new IDMA iterative detection aided quantum spatial coupling NOMA scheme, which relied upon exploiting the intrinsic non-orthogonal characteristics of coherent state multi-user communications. This system exhibited high robustness against different practical QD imperfections, such as mode mismatch and dark counts.

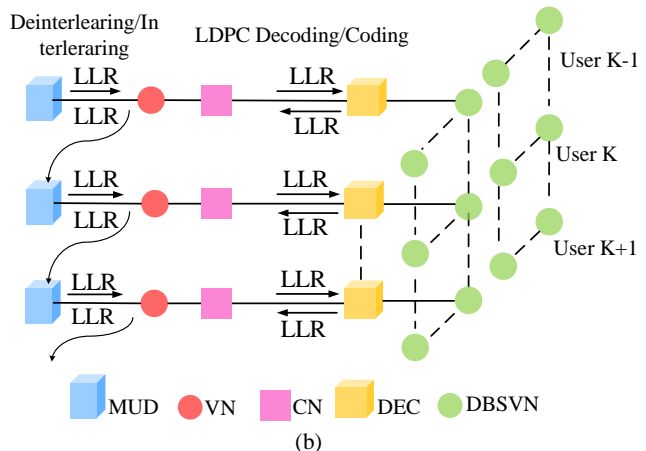
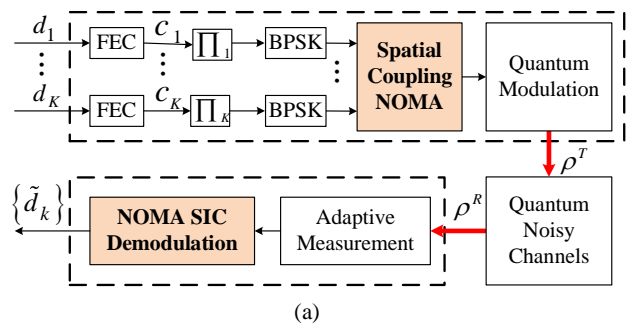

MUD: Multi-user Detection, CN: Check Node, VN: Variable Node, DEC: Detector, DBSVN: Decoded Bit Sequence Variable Node, LLR: Log-Likelihood Ratio

Fig. 15. The schematic of an IDMA-based iterative multi-user NOMA-QKD system. The proposed system is designed with an iterative detector that detects photons having different polarization states once the quantum measurement is completed. Then, the *a-priori* and *a-posteriori* LLRs of the QD signals are exchanged iteratively using an iterative multi-user detection method [183], [212].

C. Quantum MIMO

The classical MIMO technique aims to improve the BER and/or increase its channel capacity by harnessing multiple transmission channels created by multiple antennas within the system. Quantum communications were also shown to benefit from the employment of MIMO techniques [44], [184], [185], [213], [269] relying on the architecture of Fig. 16 by exploiting that quantum states can be transmitted over several quantum channels. The MIMO diversity beneficially can be exploited to effectively reduce the deleterious impact of quantum channel impairments, such as quantum noise, depolarization and atmospheric turbulence imposed on the fragile quantum states. Furthermore, QD MIMO multichannel multiplexing has the potential to increase the quantum system's capacity significantly. For quantum MIMO systems, the entanglement effect can provide a unique information channel, potentially increasing the degree of freedom in the quantum system. Tab. IX lists some of the salient research contributions on quantum MIMO solutions at a glance.

Yuan *et al.* [184] proposed a FSO quantum communication system relying on receiver diversity using an optical combining technique [294] and a generalized Kennedy receiver [295].

TABLE IX
A SUMMARY OF QUANTUM MIMO, WHERE \checkmark INDICATES THAT THE SYSTEM BRINGS CORRESPONDING GAIN EFFECT, AND A BLANK SPACE INDICATES OTHERWISE

Remark	Spatial diversity	Spatial multiplexing	Short description
[184]	\checkmark		A receiving diversity FSO quantum communication system in turbulent channels
[185]	\checkmark	\checkmark	A non-orthogonal coherent-state MIMO uplink scheme over noisy quantum atmospheric turbulence channels
[269]		\checkmark	The MIMO CVQKD scheme based on the application of THz frequencies at room temperature
[44]		\checkmark	A channel estimation scheme for THz MIMO CVQKD systems
[213]		\checkmark	A new mathematical model to analyze the effect of crosstalk and interference on the performance of the MIMO QKD system

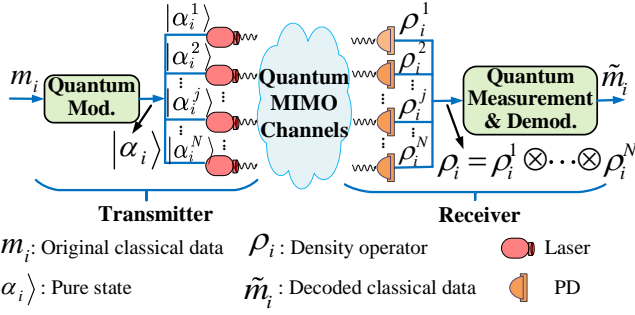

Fig. 16. Quantum MIMO. Quantum states can be transmitted over several quantum channels. The MIMO diversity effect can effectively reduce the impact of quantum states from quantum channel impairments, such as quantum noise, depolarization, and atmospheric turbulence. Furthermore, quantum MIMO multichannel multiplexing can significantly increase the quantum system's capacity [44].

Specifically, a threshold-detection-based Kennedy receiver was harnessed to mitigate the influence of both turbulence and thermal noise. Their simulations confirmed that the proposed threshold-detection-based receiver outperformed the SQL given by the homodyne receiver. As a further advance, Kundu *et al.* [269] explored the employment of multiple antennas in the THz band for a MIMO CVQKD scheme. They proposed a transmit-receive beamforming scheme using singular value decomposition (SVD) and derived an analytical expression for the secret key rate of the proposed MIMO CVQKD system. Their simulations demonstrated that the MIMO CVQKD scheme outperforms a traditional single-input single-output (SISO) system in terms of its secret key rate vs. the transmission distance. Additionally, multiple antennas applied in the THz have the potential to mitigate path loss. Kundu *et al.* [44] also conceived a channel estimation scheme for the THz MIMO CVQKD system considered. This system utilized optical-to-THz and THz-to-optical converters for QD signal transmission and detection, and again, an SVD-based beamforming method was employed at both the transmitter and receiver. During the key generation phase, the input-output relationship between Alice and Bob was characterized by

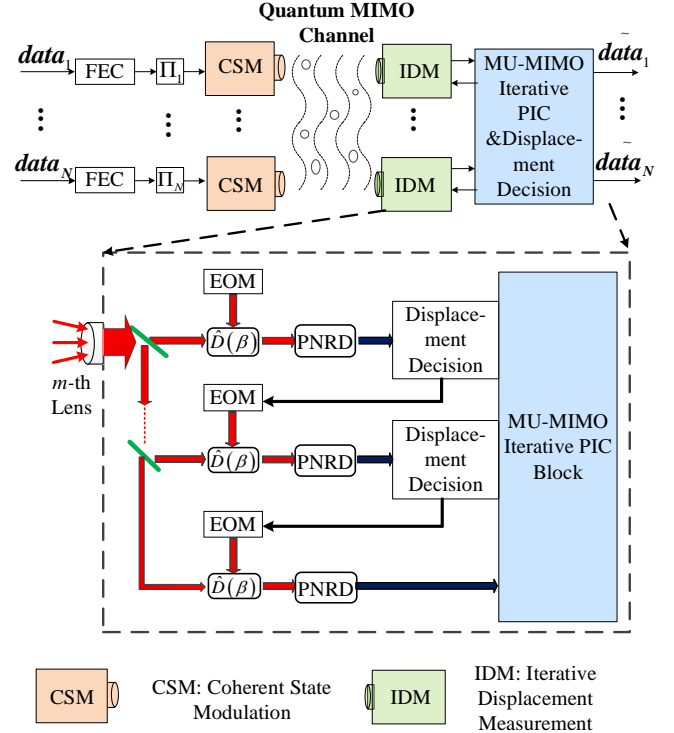

Fig. 17. A non-orthogonal coherent-state MIMO uplink system over noisy quantum atmospheric turbulence channel. At the transmitter, the information bit sequences are borne by the coherent state optical QD signals presented on the infinite-dimensional orthogonal basis of Hilbert space. The receiver's detection scheme relies on the iterative displacement quantum measurement and the iterative massive MIMO PIC detection [185].

incorporating the channel estimation overhead, the additional noise arising from the channel estimation error, and detector noise. Furthermore, the effect of both the channel estimation error and of the pilot overhead on the secret key rate of the system was analyzed.

A communication system relying on MIMO QKD based on the BB84 protocol [296] was devised in [213] for increasing the secret key rate. This was achieved by harnessing

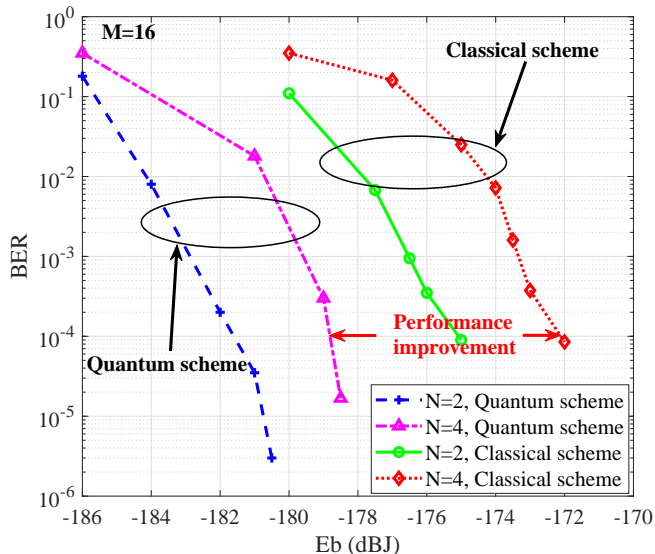

Fig. 18. Comparison of the proposed quantum MIMO scheme and the classical scheme under strong turbulence fading. In the case of $N \times M = 4 \times 16$, the proposed quantum scheme is able to achieve an improvement of 6.25 dBJ per bit in performance at a BER of 10^{-4} for a Gamma-Gamma fading link [185].

multiple receivers to communicate concurrently with multiple transmitter elements. However, this technique is proven to have interference effects due to scattering and turbulence in atmospheric channels, which reduces the secret key rate of the system and increases the QBER. Hence, the authors put forward a new mathematical model for analyzing the effects of crosstalk and interference on the performance of MIMO QKD systems.

To elaborate further, Zhou *et al.* [185] proposed a non-orthogonal coherent-state MIMO uplink system for transmission over noisy quantum atmospheric turbulence channels. As seen in Fig. 17, this system comprises N transmitters and a base station having M receivers. The information bit sequences are conveyed by the coherent state optical QD signals spanning the infinite-dimensional orthogonal basis of Hilbert space from the transmitter to the receiver. The atmospheric turbulence fading channel encountered is modeled by the Gamma-Gamma distribution. Then, the received QD signals' statistical model is established. The receiver's detection scheme relies on the iterative displacement-based quantum measurement philosophy and on iterative massive MIMO-based parallel interference cancellation (PIC) aided detection. This iterative massive MIMO PIC detector realizes interference cancellation through iteratively exchanging the *a-priori* and *a-posteriori* LLR information. Fig.18 compares the BER performance of this quantum multi-user MIMO scheme [185] to that of a classical scheme [297]. In the case of $N \times M = 4 \times 16$, this quantum scheme was shown to achieve an improvement of 6.25 dBJ per bit at a BER of 10^{-4} for a Gamma-Gamma fading link. In conclusion, this quantum scheme exploited the multi-dimensional nature of the QD signal by relying on the above-mentioned multi-stage displacement measurements.

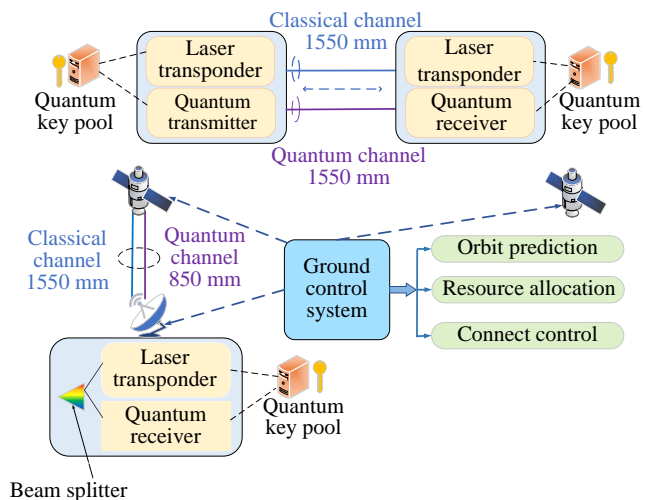

Fig. 19. The basic structure of the QKD satellite system enabled by the quantum key pool. Each node has a quantum transceiver, a laser transceiver, and a quantum key pool. Routing selection and key distribution are determined by the control system. Satellites and controllers can be connected via radio or optical links [298].

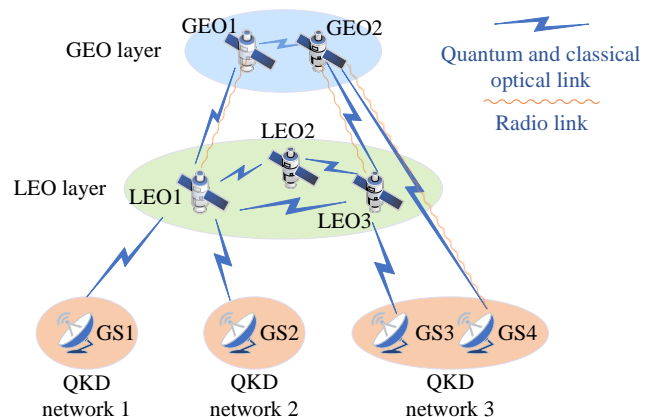

Fig. 20. Network architecture for double-layer quantum satellites. Quantum satellite nodes are composed of LEO and GEO satellite layers. Satellites in the same orbital layer are connected by inter-satellite links, and a satellite can communicate with another satellite in a different orbit layer via an inter-orbital link [298].

D. Quantum Relays

Long-distance QKD requires sophisticated quantum relaying techniques [186], [300]. Quantum relays have been harnessed by LEO satellites, high-altitude platforms (HAPs), and terrestrial quantum network nodes on the ground [186], [300]. Relay-aided QKD networks tend to ensure secure encryption of each link by a dedicated secret key and facilitate end-to-end global key exchange between the source and destination. Routing algorithms meeting specific quality-of-service (QoS) considerations have also been studied in QD relay networks [218]. Furthermore, experimental progress has shown the feasibility of QD relay techniques across multiple countries and even continents [301].

To elaborate further, Wang *et al.* [300] proposed a QKD network harnessing LEO satellites for relaying long-distance QKD requests and for achieving intercontinental QKD. Huang

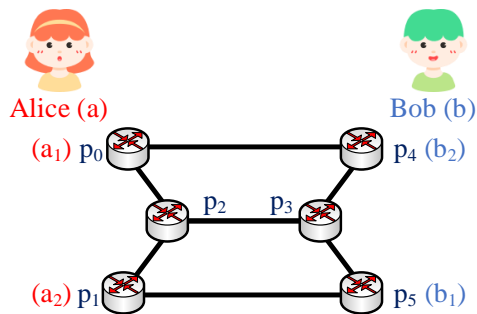

Fig. 21. Butterfly quantum network. Multipath networking utilizing the endpoints as relays in a network allows multiple messages to be transmitted concurrently [299].

et al. [298] developed a new architecture for global quantum-domain satellite networks, overcoming the limitations of single-layer satellite networks. Their architecture includes a trusted-repeater layer and a second layer that employs a quantum key pool for supplying secret keys to ground stations. As shown in Fig. 19, the system consists of nodes having quantum transceivers, and each node is assigned a secret key for its routing selection. The architecture enables communication between satellites in different orbital layers, forming a global QKD network [298], as shown in Fig. 20.

HAPs, such as airships, balloons, or manned/unmanned aircraft, can serve as auxiliary relays between LEO satellites and mobile stations [186]. In FSO/QKD systems, typically, a dual-threshold/direct detection scheme is used while considering realistic scenarios of misaligned transceivers, receiver noise, and atmospheric turbulence [186]. The effects of system parameters such as the intensity modulation depth, optical amplifier gain, and the dual-threshold scaling factor on the level of communication security were also evaluated [186].

For characterizing long-distance quantum communication, Pirandola *et al.* [299], [302], [303] investigated the pros and cons of quantum repeaters in multi-hop quantum networks in terms of the transmission of quantum information, entanglement distribution and secret key generation. As shown in Fig. 21, multipath networking utilizing the endpoints as relays in a network allows multiple messages to be transmitted concurrently [299]. Additionally, tailor-made coding schemes may be designed for classical-quantum relay channels, including multihop, coherent multihop, decode-forward, and partial decode-forward relaying schemes [304], [305].

E. Summary

In this section, we briefly highlight some of the technologies that could be utilized for quantum-enabled PHY in future native quantum systems. These technologies encompass multi-band quantum access, multi-user quantum communications, quantum MIMO, and quantum relays. By comparing the performance of quantum systems and the theoretical limits of classical systems, we observe that quantum communication is potentially capable of outperforming classical communication in terms of its error probability, as seen in Fig. 11. This capability might facilitate the support of new applications such as

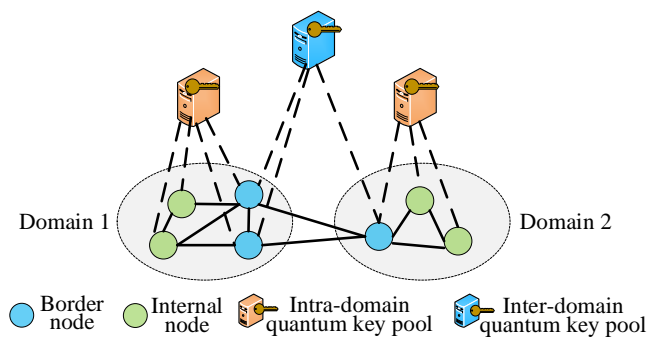

Fig. 22. Multi-domain QKD optical network. In the case of a multi-domain QKD optical network, the intra-domain quantum key pool of every intra-domain quantum key pool node and the inter-QKP of every boundary node is indispensable. Service allocation will be determined by how key resources generated on direct and non-direct links are used to supplement key pools [217].

holographic communications and the metaverse. Moreover, a community effort is required to extend point-to-point quantum communications to multipoint-to-multipoint scenarios suitable for ultra-dense connections in the future, such as multi-user quantum communication for the quantum IoT and quantum MIMO systems that exhibit resistance to atmospheric turbulence.

However, achieving QD multiple access in support of multiple users sharing entangled quantum states poses significant challenges. The fragility of entangled states and their susceptibility to environmental impairments and noise over long distances hinder the maintenance of coherence. Distributing entangled states among multiple users requires specialized equipment and presents substantial practical implementational challenges.

Furthermore, the computational complexity of quantum communication systems in the face of multi-user access presents another hurdle. The limited availability of quantum computing hardware poses a significant practical barrier, as quantum computers are still in their infancy and not yet widely accessible. This limitation restricts the performance of multi-user quantum communication systems and presents challenges in realizing such systems in real-world settings.

VI. QUANTUM MAC AND UPPER LAYER ISSUES

In this section, we investigate the key technologies of the native quantum MAC layer, touching upon quantum resource allocation, quantum routing, quantum multiplexing and quantum-secured network services as a whole.

A. Quantum Resource Allocation

Compared to classical communications, quantum information transmission relies on more complex resource allocation. Researchers have dedicated significant efforts to developing resource allocation algorithms for QKD networks, such as the wavelength, fiber core, and time slot allocations within WDM-based QKD architectures. Furthermore, QKD has been integrated both with classical software-defined networking (SDN) [308] and network function virtualization (NFV) [309]

TABLE X
A SUMMARY OF QUANTUM RESOURCE ALLOCATION

Scenario	Technique	Examples
Quantum and classical channels coexisting in a dense WDM system	Channel allocation strategy for both QD and CD signals	[214]
Elastic optical networks with MCFs	Resource allocation for QChs and CChs of QKD and DChs	[215]
Satellite-based QKD systems	LDPC code-based, rate-adaptive reconciliation schemes	[306]
Joint QKD-post-quantum cryptosystems	A scalable spatially coupled LDPC code	[182]
Optical networks secured by QKD	Two key-volume protection schemes considering key-updating and key-volume routing	[216]
Multi-domain QKD optical networks	Multi-domain quantum key pool capacity adaptive supplement scheme based on the balance of key resources and route hops	[217]
Multi-core optical networks	Routing, core, and wavelength allocation algorithms	[307]

to provide flexible supervision and uninterrupted secret key provision [309], [310]. The challenge is that the generation of secret keys is a painstakingly slow and tedious process, which must supply new keys as frequently as possible. In recent years, quantum-domain techniques, such as quantum games, have been shown to exhibit promise in resource allocation, supplementing traditional game theory and convex optimization methods [217]. Tab. X lists some research on quantum resource allocation.

To achieve seamless global connectivity, future core networks are expected to be multi-domain networks where autonomous systems collaborate. As the network scale and flawless connection requirements between different equipment manufacturers escalate, multi-domain optical networks become a practical area of study. In such networks, the adjacent nodes within a single domain must mutually endorse the negotiation and generation of key resources. However, having both intra-domain and inter-domain quantum key pools becomes indispensable in multi-domain QKD optical networks. Quantum key resources are valuable, and excessive service requests may quickly deplete the key pool. Wang *et al.* [217] proposed an adaptive scheme for multi-domain QKD in optical networks, which carefully balances the demand for the number of hops, improving both the service-blocking probability and the key resource utilization, as shown in Fig. 22.

Wang *et al.* [216] developed a pair of schemes for controlling the key volumes in optical networks using QKD. These schemes incorporate key-volume-dependent adaptive routing and a key update mechanism, offering a reliable solution for allocating and protecting resources. Their simulation results demonstrated that shared key-volume-dependent adaptive algorithms outperform their non-shared counterparts in terms of both blocking probability, time-slot utilization efficiency, and proportion of secret key “consumption”. Notably, both of their key-volume-dependent adaptive protection schemes

provide robustness against link failures.

In the context of multi-core optical networks, Yu and colleagues [307] proposed a set of four routing, core, and wavelength allocation (RCWA) algorithms. These RCWA algorithms, namely RCWA using spectrum perception (RCWA-SP), RCWA employing crosstalk perception (RCWA-XTP), RCWA operating without perception (RCWA-WP), and RCWA with core perception (RCWA-CP), relied on different core-allocation schemes. Specifically, RCWA-SP selects the channel having the least busy wavelength to optimize network resource utilization. RCWA-XTP preserves cores to prevent interference between the quantum core channel and other types of requests. RCWA-WP and RCWA-CP impose reduced complexity but may exhibit eroded performance. The authors of [307] compared the blocking probability of service requests, the utilization efficiency of secret keys, and the average crosstalk intensity of QD signals in RCWA-based optical QKD networks. Numerical results demonstrated that RCWA-SP reduces the blocking probability, while RCWA-XTP minimizes inter-core crosstalk [307].

B. Quantum Routing

Yang *et al.* [218] proposed a QKD connection protocol associated with key-rate-aware routing, aiming for finding the optimal relay path for secure key exchange. They introduced a dynamic model that predicts the quality of the remaining local keys, taking into account link loss and relay path considerations. By using a cost function, the model automatically steers the relay to route to a faster key generation link since links having higher generation rates incur lower costs. The algorithm also considers the impact of previous key exchanges on the current exchange, capturing the correlation between the local key generation and its cost over time. Their routing approach aims for increasing the success rate of key exchanges, promoting equal participation of all QKD links

TABLE XI
 QUANTUM MULTIPLEXING AND RESOURCE ALLOCATION AND THEIR POTENTIAL APPLICATIONS IN FUTURE COMMUNICATIONS, WHERE \checkmark INDICATES THAT THE PAPER COVERS THE CORRESPONDING TECHNIQUE, AND A BLANK SPACE INDICATES OTHERWISE

Tech. Paper	Key distribution	Multiplexing	Routing	Wavelength allocation	Time allocation	Potential use case in the future
[214]	\checkmark	\checkmark		\checkmark		Optical fibre communication network
[215]	\checkmark	\checkmark				Elastic optical network
[217]	\checkmark		\checkmark			Multi-domain optical core network
[216]	\checkmark		\checkmark			Optical network
[306]	\checkmark					Space-based implementations of single-photon QKD
[182]	\checkmark					Optical network
[311]	\checkmark	\checkmark		\checkmark		Optical fiber network
[312]	\checkmark	\checkmark				Optical fiber network
[313]	\checkmark	\checkmark				Optical telecommunication system
[314]	\checkmark	\checkmark		\checkmark		QMAN
[315]	\checkmark	\checkmark		\checkmark		Optical fiber network
[310]	\checkmark	\checkmark	\checkmark	\checkmark	\checkmark	Optical network
[316]	\checkmark	\checkmark	\checkmark	\checkmark	\checkmark	Optical network
[307]	\checkmark	\checkmark	\checkmark	\checkmark		Multi-core optical network

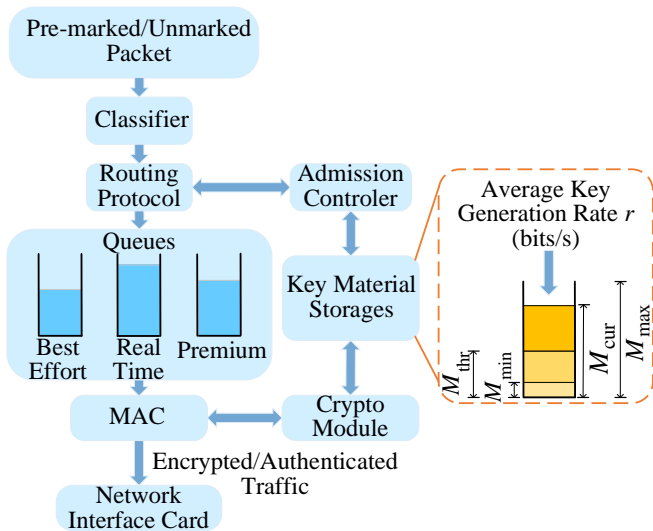

Fig. 23. Flexible QoS model for QKD networks and traffic processing. The flexible QoS model distinguishes three traffic classes with the corresponding differentiated services, namely, best-effort, real-time, and premium classes [317].

in the exchange process and balancing the load, local key generation, and cost among the QKD links.

In support of multi-relay scenarios, the node structure can be optimized [318]. By incorporating the concept of multi-relay nodes in [318], a new multi-point key-relaying scheme was designed, which can be further extended to multi-relay schemes and key-relay trees. Additionally, a routing and key assignment algorithm based on the key-relay tree was developed and evaluated in both dynamic and static scenarios [318]. Their simulation results demonstrated that the key-relay-tree-based routing and key assignment approach outperforms its counterparts in terms of securing multicast services, reducing overflow probability, and minimizing the average number of keys used per secure multicast service.

Mehic *et al.* [317] discussed a wide range of challenges faced by QKD networks, including their low key rates, limited link distances, and vulnerability to passive eavesdropping. They conceived a distributed approach to manage traffic loads without relying on any flow or session information. Additionally, they proposed a greedy routing policy relying on a classifier, a queue, a controller, a crypto module, and dynamic admissions regulation, as seen in Fig. 23. Their flexible QoS model differentiates three traffic classes: best-effort, real-time,

and premium. The performance of their greedy routing policy is evaluated by simulations, considering the routing protocol overhead, packet delivery ratio, and path length. The resultant QKD network – which exploits QKD’s provably secure nature and ability to create private key bits over a public channel – exhibits superior performance over traditional QKD networks.

C. Quantum Multiplexing

WDM offers several benefits in addition to supporting clustered BS deployments, including the extension of radio access networks (RANs) to decentralized and heterogeneous RANs, while enhancing communication network flexibility and transparency. It enables the reuse of passive optical networks or metro rings for transporting various types of traffic, and facilitating multi-modal data transmission in future wireless communication systems. Furthermore, WDM-based QKD networks can be employed for secure communications. However, it is crucial to investigate the allocation of frequencies, time, power, and wavelengths in WDM-based quantum networks. Tab. XI collates the salient examples of quantum multiplexing and resource allocation.

In this context, Patel *et al.* demonstrated the employment of dense WDM for QKD, while supporting 10 Gb/s bidirectional classical channels in a single fiber [311]. Urena *et al.* [312] evaluated a multi-core fiber (MCF) based QKD link constructed using spatial division multiplexing (SDM). Their analysis explored the feasibility of stand-alone QKD transmission for QKD-only channels and the simultaneous transmission of QKD and classical channels. Their simulation results using the net key rate as a performance measure showed that a typical homogeneous MCF having low inter-core crosstalk can support multiple quantum channels. However, the presence of both quantum and classical channels can lead to excessive crosstalk between the cores, necessitating the use of a heterogeneous fiber to reduce crosstalk and enhance the feasibility of SDM-QKD transmission.

The compatibility of QKD with classical communication in SDM transmission was also investigated by Lin *et al.* [313], who conceived analytical models of noise sources in QKD links for transmission over heterogeneous MCFs. Their analysis focused on intra-core crosstalk and intra-core spontaneous Raman scattering. They obtained lower bounds for the secret key rates and the QBER, considering different core and wavelength allocations. In another study, Cai *et al.* [314] demonstrated QKD using CD signals over a seven-core fiber and developed a wavelength-space division multiplexing (WSDM) strategy for the simultaneous transmission of QD and CD signals in an MCF optical system. By appropriately allocating cores and wavelengths, they efficiently mitigated the inter-core crosstalk. Eriksson *et al.* [315] showcased the co-propagation of QKD signal with a large number of WDM-based coherent classical data channels, achieving a data rate of 18.3 Tbits/s when a CVQKD channel was jointly transmitted with 100 classical WDM channels. Their experimental validation demonstrated significant improvements in the number of WDM channels and bit rate compared to previous co-propagation results.

Zhao *et al.* [310] conducted a study of resource allocation in QKD-secured WDM-based optical networks. They proposed a QKD-enabled network architecture, where an SDN controller is responsible for allocating different wavelengths to the classical data channel, the QD signal channel, and the public interaction channel using WDM. To address this allocation problem, they designed a new routing, wavelength, and time-slot allocation (RWTA) algorithm. This algorithm integrated classical routing algorithms, such as the K -shortest path and Dijkstra’s algorithms, as well as classical channel allocation algorithms such as first-fit wavelength allocation [310]. Their simulation results revealed that the key updating period significantly affects the blocking probability of the QD signal channel. The blocking probability increases as the key updating periods decrease, while the security performance improves.

Cao *et al.* [316] proposed a QKD-over-WDM architecture for decoupling the secret keys from the infrastructure and for ensuring the timely provision of secret keys. This paper presented the first-ever time-scheduled QKD scheme specifically designed for WDM networks. The authors introduced the RWTA problem, which involves subproblems such as persistent or dynamic secret key consumption, even or uneven time-slot allocation, and continuous or discrete quantum key provision. To tackle these challenges, they developed a computationally efficient heuristic RWTA algorithm. Their simulation results demonstrated the efficiency of this algorithm in implementing QKD scheduling for transmission over WDM networks.

These latest studies highlight the potential of WDM-based techniques in enabling high-capacity and secure quantum communication and emphasize the importance of optimizing the system parameters in the allocation of resources for QKD in WDM networks.

D. Quantum Network Service and Architecture

As discussed in [12], NG networks are envisioned to support various intelligent services and applications, including autonomous driving, virtual reality, space-air-ground integration, and smart cities. The increasing number of connected quantum user equipment (UE) and IoT devices may require different QoS from the core network, such as data rate and delay, which traditional RANs struggle to satisfy. To address this challenge, open RAN (O-RAN) has emerged as a promising technique that can simultaneously meet the diverse demands of different applications by treating services separately. In an O-RAN, some applications can connect directly to the core network, while others are diverted through various stages of radio control functions.

However, O-RANs are computationally complex and prone to security attacks in different layers [12]. It is critical to investigate and integrate techniques that can reduce system complexity and enhance the security level, such as NFV, mobile edge computing (MEC), and encryption by QKD [12]. Tab. XII summarizes the key technologies in quantum networking.

The use of GHZ states in a quantum wireless network communication was demonstrated in [320]. The study proposed a

TABLE XII
A SUMMARY OF QUANTUM-SECURED NETWORK SERVICE

Scenario	Technique	Examples
QKD over optical backbone networks	Hybrid trusted/untrusted relay based QKD deployment	[319]
Multi-user quantum communication system	A self-organized bilayer network	[320]
Dynamic quantum-secured optical network	Link distributed VNFs in an optical network	[309]
Layered and flex-grid fiber network	Flex-grid entanglement distribution	[321]
A new network paradigm with the QKD-generated keys integrated with IPsec sessions	Key synchronization and information transmission for an encrypted channel	[322]
Integration of SDN and QKD	A monitoring SDN for the real-time secret key rate and QBER	[323]
Multi-tenant QKD network	A multi-tenant QKD network design utilizing SDN and QKD for secure distribution of keys to tenants within the network.	[308]

generic expression for the final qubit state within a multi-user network architecture, reducing computational complexity and resource consumption [320]. The authors suggested that the multi-qubit GHZ state is more suitable for constructing the network architecture due to its characteristic of multiple particles [320]. Accordingly, they proposed an architecture with a flexible self-organized bilayer network generating GHZ states and a corresponding communication protocol [320]. The communication efficiency and security of the scheme were analyzed. In [309], a quantum-secured optical network was proposed using a network of virtual network functions (VNFs) linked across multiple network domains. The study combined dynamic and flexible optical networking with an SDN-enabled optical control plane and NFV orchestration to make VNFs quantum-aware and chainable on-demand [309]. The proposed framework allowed both the dynamic establishment of new network services and the reconfiguration of existing ones [309]. Experimental results verified the independent and dynamic routing of quantum and classical data channels over a shared optical fiber link [309].

Aguado *et al.* [322] considered the scenario of combining QKD systems with secure end-to-end services between remote premises. They conceived control plane workflows and protocol extensions for supporting quantum encryption services to operate in conjunction with multi-protocol label switching [322]. The integration of QKD-generated keys in IPsec sessions allowed major control plane protocols like OpenFlow and NETCONF to be integrated into novel network paradigms [322]. By intrinsically combining the QKD infrastructure layers, SDN, and applications, it became possible to support uninterruptible key service provision in the face of link-level attacks with the aid of flexible supervision [323].

Real-time monitoring of quantum parameters allows the deployment of an SDN framework with a quantum-aware network control application in a QKD-enabled optical network [323]. This framework minimizes delay associated with the

identification and reallocation of secure quantum paths to avoid link failures [323]. A multi-tenant QKD network architecture utilizing SDN and quantum key pool techniques was proposed by Cao *et al.* in their work [308]. The architecture incorporates a heuristic algorithm and a secret-key rate-sharing scheme to facilitate multi-tenant secret key assignment. This approach enables efficient and secure key management for multiple tenants within the network. Furthermore, Cao *et al.* [319] introduced a QKD network architecture specifically designed for optical backbone networks, employing a combination of trusted and untrusted relays. The authors carefully considered the node structures of these relays and formulated corresponding network, cost, and security models. To optimize the deployment cost, they developed an integer linear programming model along with a heuristic algorithm.

E. Quantum Security Strategy

Li *et al.* [324] proposed a security strategy for QSDC using an improved Ping-Pong protocol, as shown in Fig.24(a). Hyper-entangled states were utilized as decoy states [325] to enhance eavesdropping detection probability. The protocol involved the formation of data sequence D by inserting a hyper-entangled state-checking sequence C into sequence A, which was prepared by Bob using ordered EPR pairs. Alice performed measurements on the sequences, encoded the secret messages, and inserted new hyper-entangled states into sequence A for transmission. The security level of the channel was confirmed through Bell measurements performed by Bob.

In a different approach, Yang *et al.* [286] proposed a QSDC protocol utilizing entangled photon pairs, as shown in Fig.24(b). Unlike existing protocols, this method involved measuring one photon of the entangled pair after the entanglement distribution. Alice generated EPR pairs and collected particles for transmission while keeping a pair for herself, and Bob measured the received photons and informed Alice about their non-vanishing positions. Through measurements and

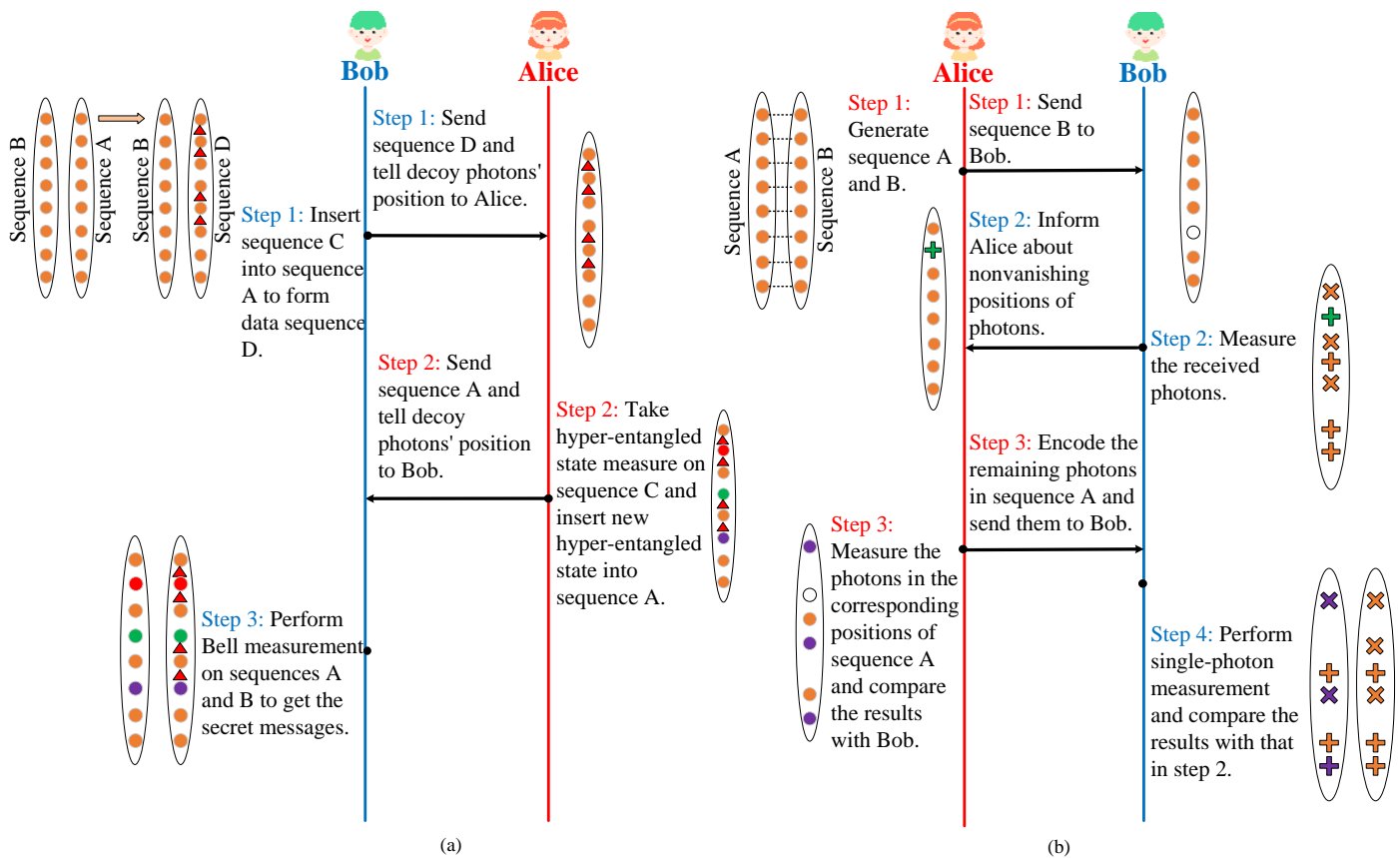

Fig. 24. QSDC protocols. (a) A new security strategy for QSDC using an improved Ping-Pong protocol. The red triangles represent the particles in hyper-entangled state $|\Phi^+\rangle_{ps}$, the orange circles represent the EPR pairs in state $|\psi^-\rangle$, the green, purple and red circles represent EPR pairs in states $|\psi^+\rangle$, $|\varphi^-\rangle$ and $|\varphi^+\rangle$ respectively [324]. (b) A QSDC protocol utilizing entangled photon pairs. The orange circles connected by the dotted lines are entangled photons, and the white circles indicate the photons lost in transmission. The symbols + (Z-basis) and × (X-basis) indicate the single-photon measurement results. The remaining photons in step 3 represent Alice encoding the secret message through unitary operations I (orange) and σ_y (purple), respectively [286].

comparisons, Alice ensured the secrecy of the communication. The remaining photons in sequence A were encoded by Alice, and the encoded photon was sent to Bob after inserting check bits. Bob performed single-photon measurements, and the results were compared with previous measurements. Simulation results demonstrated increased secrecy capacity due to the heralding function of the entangled photons.

Rong *et al.* [326] presented a semi-QSDC protocol enabling bi-directional information transfer between a quantum-capable Alice and a classical Bob using single-photon transmission and Bell states. The protocol allowed the legitimate user to directly read the message upon receiving the quantum state and prevented encoded messages from being leaked to eavesdroppers, even if they controlled the channel. By employing GHZ states and quantum networks, the protocol showed potential for secure and efficient communication in various applications, including private query systems involving third parties. Furthermore, a controlled bidirectional QSDC protocol was proposed in [327] utilizing six-qubit entangled states, where Bell basis measurements and single-particle measurements were performed. The protocol was controlled by a third party named Charlie, who generated the six-qubit states and ensured security by inserting decoy states into the sequence sent to Bob.

In space-based QKD systems utilizing entanglement-based protocols like the BB84 protocol, Ai *et al.* [306] investigated LDPC code-based rate-adaptive reconciliation schemes. They compared adaptive-rate LDPC codes to fixed-rate non-adaptive LDPC codes in a setup, where Alice and Bob are located at the ground stations 1000 km apart, and a LEO satellite generates and distributes entangled pairs of photons at an altitude of 500 km. The results show that adaptive-rate LDPC codes significantly improve the key rates for space-based QKD applications, offering higher flexibility compared to fixed-rate reconciliation schemes.

Djordjevic *et al.* [182] proposed a joint QKD-post-quantum cryptosystem in their work for enhancing the key rate vs. transmission distance trade-off. This cryptosystem combines a post-quantum cryptography-based subsystem associated with QKD to improve the reconciliation of information. By incorporating the QKD subsystem, the cryptosystem reliably prevents information leakage and detects eavesdroppers. This method significantly increases the transmission distance, which is a benefit of minimizing information leakage during reconciliation. Additionally, Djordjevic and his colleagues [182] also developed a scalable spatially coupled LDPC code that can be configured in real time. Their simulation results demonstrated that a twin-field-QKD-McEliece cryptosystem achieves

a distance of 1238 km over ultra-low-loss fiber, assuming an eavesdropper employing a quantum information set decoding attack.

F. Summary

This section explored the critical technologies of quantum-native MAC and of the upper layers. Future networks may be expected to integrate multiple domains, necessitating efficient resource allocation algorithms for quantum information transmission. Some studies have extended mobile ad-hoc networking concepts to address the QoS of QKD networks. Additionally, quantum communication systems can leverage WDM, SDM, and WSDM technologies to enable secure communications. Real-time monitoring of key rates and QBERs can be achieved with the aid of SDN and NFV.

However, it is important to consider the limitations of quantum protocols. Quantum information transmission is susceptible to losses and noise, which can restrict the distance over which quantum communication is viable. Furthermore, the creation and manipulation of quantum states require specialized equipment, presenting challenges in practical implementations of quantum protocols. Additionally, quantum protocols tend to be more intricate than classical protocols, posing difficulties in analytical and conceptual challenges. These limitations contribute to the complexities associated with developing and implementing quantum protocols in real-world scenarios, such as the quantum Internet of the future.

VII. QUANTUM AI AND COMPUTING FOR FUTURE COMMUNICATIONS

Quantum information and AI constitute a pair of pivotal technologies in future communications. Integrating quantum technology with AI offers significant advantages, capitalizing on the rapid advancements in both fields. A compelling application is found in the domain of quantum edge computing, which can provide an integrated and secure edge cloud platform for users in various industries such as banking, insurance, public security, e-commerce, and mobile communications [328].

This section delves into several key areas, including quantum search algorithms, quantum error mitigation techniques, quantum optimization algorithms, quantum neural networks, and other quantum machine learning models. Through this exploration, we aim to uncover novel avenues for leveraging the potential integration of quantum technologies and AI, opening up new possibilities for future advances in communication systems.

A. Quantum Search Algorithms

A quantum search algorithm relies on quantum mechanics to search through a database or other data structures, which can be substantially faster than classical search algorithms. A celebrated quantum search algorithm is Grover's algorithm [329], which can search through a database of N items in $\mathcal{O}(\sqrt{N})$ time [330]. By contrast, the best classical algorithm, i.e., the iterative interval-halving based search algorithm of [331],

would take on the order of $\mathcal{O}(N)$ time [109]. The applications of quantum search algorithms include searching through large databases, finding a specific item in an unsorted list, and solving optimization problems.

A research study conducted by Botsinis *et al.* [109] investigated the potential of quantum algorithms to solve large-scale search problems encountered in classical wireless communication systems, especially in the physical and network layers. The authors considered a suite of optimization problems, such as multi-user detection, channel estimation, and finding optimal transmit precoding weights and routes, for example. They compared the performance of quantum-assisted solutions to traditional methods and found that quantum algorithms can offer improved performance at a given level of complexity. As a further development, Chandra *et al.* [332] surveyed a suite of wireless problems, where quantum search algorithms require a substantially reduced number of cost-function evaluations compared to their classical counterparts. The authors of [332] argued that quantum technologies are promising to improve communication systems in speed, security, and efficiency. Mondal *et al.* [333] proposed a semi-quantum framework to reduce the query complexity of both the Durr-Hoyer algorithm [334] and of the Boyer-Brassard-Høyer-Tapp [335] algorithm. Their simulation results characterizing a MIMO-OFDM system showed that the symbol error rate performance of the proposed algorithm was close to that of the classical maximum likelihood search. However, these algorithms require specialized quantum computing hardware, which in turn calls for radical further research in order to solve the above-mentioned problems on the practical scale of realistic wireless systems.

B. Quantum Error Mitigation and Quantum Error Correction

The interaction of the delicate quantum systems with the environment inevitably results in decoherence, which has to be mitigated with the aid of quantum error control techniques. The two main categories of quantum error control are constituted by quantum error correction coding (QECC) and quantum error mitigation (QEM) [336]–[339] techniques relying on diverse quantum signal processing methods, but excluding quantum correction codes.

As for the family of QECCs, Babar *et al.* [340] provided a detailed tutorial on the duality between classical and quantum coding theory and offered a step-by-step guide on creating stabilizer-based quantum error correction codes (QECCs). They also conceived in-depth design examples relying on the classical vs. quantum Bose-Chaudhuri-Hocquenghem and convolutional code families.

However, since the implementation of quantum hardware is still in its infancy, in a series of studies [341]–[344], Chandra *et al.* explored the performance of low-complexity quantum codes having modest hardware requirements. To elaborate briefly, in [341], they quantified a number of quantum coding bounds and derived closed-form approximations of the minimum distance vs. coding rate relationship of quantum codes. Naturally, longer codes tend to exhibit higher minimum distance than their shorter counterparts, hence they normalized

the minimum distance by the code length for the sake of fair comparison of different-length codes.

In another intriguing study Nguyen *et al.* [342] investigated the hypothesis of whether it is feasible to harness network-coding principles in the quantum domain and in this context conceived a relatively large-scale quantum network coding scheme for disseminating entangled qubits via teleportation and QKD. They described the process of encoding and decoding entangled qubits to pairs of users connected through multiple intermediate nodes. Nguyen *et al.* [343] also studied the Hashing bound of entanglement-based quantum channels and paved the way for harnessing the powerful design tool of Extrinsic Information Transfer Charts (EXIT) for improving the normalized throughput of realistic quantum devices.

In [344] Chandra *et al.* revisited the family of classical topological error correction codes having codeword bits arranged in a lattice structure and exploited the so-called “classical-to-quantum isomorphism” to construct their quantum dual pairs. To demystify this concept, please refer to Babar *et al.* [340], where it is unveiled, how to create the QD counterpart of a classical QECC. They also analyzed the QBER and fidelity of these codes when exposed to a quantum depolarizing channel and quantified the specific depolarizing probability, below which the QECCs considered were capable of mitigating the QBER under the conditions considered. As another ingenious solution, Cuvelier *et al.* [345] proposed a general framework for harnessing QECCs in the context of classical non-coherent detection-aided space-time block codes.

Since the depolarizing probability of quantum circuits is time-variant, Chandra *et al.* [346] conceived a family of computationally efficient variable-rate concatenated QECC designs relying on combining short block codes and unity-rate codes as outer and inner codes, respectively. More explicitly, this scheme was reconfigurable in terms of its coding rate, which can be conveniently reconfigured for accommodating different depolarizing probabilities. This scheme results in a relatively high quantum coding rate, because the unity-rate coding component clearly does not reduce the code rate and yet it succeeds in approaching the hashing-bound under the idealized simplifying assumption of having flawless QECC hardware. In [347] Chandra *et al.* demonstrated the benefits of using topological QECCs for improving the performance of Clifford gates.

However, the popular memoryless channel assumption routinely stipulated in QECC studies does not always hold in realistic hardware, because the previous error events tend to influence future errors. Hence Izhar *et al.* [348] examined quantum turbo codes (QTCs) in the face of depolarizing channels exhibiting memory and proposed a QTC scheme capable of exploiting error correlation during decoding. But again, radical new research is required for designing QECCs relying on realistic decoherence-infested hardware.

C. Quantum-Domain Optimization

Quantum game theory extends the philosophy of classical game theory by combining the principles of quantum mechanics and quantum computation with conventional games.

In this context, Xu *et al.* [360] designed a pair of quantum game models to deal with the mission assignment and quality optimization of existing crowdsourcing platforms relying on homogeneous workers. A quota-oriented crowdsourcing game was first constructed, only to reveal that no optimal strategy exists to maximize the payoffs of the workers. Then, a quantum game model was proposed to address the issue. Furthermore, the authors of [360] studied a quantum-based quality-aware crowdsourcing game using a density matrix-based method. The merits of the quantum strategy were proved by comparing the game performances of the proposed quantum version with its classical counterpart, such as the zero-sum game, for example. However, naturally, the quantum games will be relegated to their classical versions without entanglement. Their analysis showed that – as expected – entanglement is capable of enhancing the performances of all participants. As a further advance, Alanis *et al.* [361] proposed an evolutionary quantum-domain Pareto optimization algorithm for finding “almost all” of the best paths at near-polynomial complexity in wireless multi-hop networks.

Having a low delay and near-uniform tele-traffic load distribution constitute critical problems encountered in real-time vehicular communication relying on edge servers [362]. With the aim of solving this problem, a quantitative edge server deployment strategy was put forth in [362] for reducing the system delay and for balancing the workload of the edge servers. The strategy included the following steps: Firstly, the location of the edge servers was simulated. Secondly, a tailor-made fitness function was conceived and the associated distribution optimization problem of the edge servers was formulated. Finally, it was optimized by the Pareto genetic algorithm II. As a further development, Matteo *et al.* [363] studied the cost of fault-tolerant quantum random-access memory. They embedded a surface code in a circuit serving as quantum random-access memory and they also discussed the associated trade-offs in terms of the number of qubits vs. the associated run-time, and estimated the associated resource requirements.

In [364] a new MIMO-aided wireless physical layer was implemented by leveraging sophisticated quantum annealing. The associated experimental results showed that binary phase shift keying (BPSK) based communication supporting 48 users with the aid of 48 access point (AP) antennas can be achieved within a computation time of 10 μ s run on the 2,031 qubit quantum annealer, where the SNR is 20 dB and the BER is 10^{-6} . As a further advance, Kasi *et al.* [365] proposed a novel processing architecture for large-scale MIMO systems in order to solve the downlink vector perturbation-based transmit precoding problem relying on quantum annealing. El-Latif *et al.* [366] proposed new symmetric key distribution algorithms for secure encryption by exploiting the properties of quantum walks. Quantum walks constitute a popular quantum computing architecture exhibiting reliable cryptographic characteristics, which have been harnessed for 5G-IoT applications by the authors. As a further advance, the authors of [366] designed a robust video encryption system and characterized it using MATLAB R2017a.

Feng *et al.* [367] addressed the problem of maximizing

TABLE XIII
A SUMMARY OF QUANTUM NEURAL NETWORK AND OTHER QUANTUM MACHINE LEARNING MODELS

Quantum learning technique	Application	Examples
Variational quantum unsampling	Deep learning	[349]
Variational quantum circuit	Deep reinforcement learning, supervised learning	[350], [351]
Continuous-variable quantum neural network	Convolutional, recurrent, and residual networks	[352], [353]
Quantum transfer learning	Image recognition	[354]
Density-based spatial clustering	Continuous-variable quantum key distribution	[355]
Quantum circuit learning	Neural networks in near-term, low-depth quantum circuits	[356]
Quantum circuit for arbitrary unitary transformation	Data classification in quantum states	[357]
Quantum tensor network circuit	Discriminative and generative learning	[358]
Quantum generative model	Data correlation characterization	[359]

the energy efficiency of vehicular networks operating in the THz frequency band. An algorithm using particle swarms exhibiting quantum behaviour was used to create a near-optimal solution to the problem. As a further contribution, Luo *et al.* [368] determined the complex permittivities of various materials at mm-wave frequencies. Kim *et al.* [369] developed a quantum optimization algorithm to minimize the overlap between observation satellite constellations in the mmWave band. Kakaraparty *et al.* [370] discussed AI and quantum computing in the context of mmWave communication systems designed for UAVs. In the innovative contribution [371] the complexity of sparse code-based multiple access was reduced by an efficient quantum-search algorithm harnessed for multi-user detection. In an Internet-of-vehicles system supporting multiple users, a new algorithm was developed for dynamic resource scheduling [372]. This algorithm relied on a quantum-behaved particle swarm optimization (PSO) scheme designed for finding the globally optimal solution. Based on the traditional PSO algorithm, the quantum-behaved PSO algorithm was harnessed for solving potentially intractable global optimization problems. Zhang *et al.* [373] developed a network architecture relying on a combination of time and wavelength division multiplexed passive optical principles and heterogeneous cloud RAN technologies. A quantum-behaved PSO was used to solve the wavelength assignment problem in the resultant network architecture.

Li *et al.* [374] developed a quantum algorithm for MIMO systems relying on bacterial foraging optimization. The proposed algorithm outperforms both its classical bacterial foraging optimization counterpart [375] and the quantum genetic algorithm developed for solving combinatorial optimization problems. Xu and Ren [376] conceived a pilot encoding method based on quantum learning, which is capable of

operating in the face of malicious attacks. Specifically, the multi-user pilots are encoded as so-called diacritical subcarrier activation patterns. The base station then decodes the pilots from the observed subcarrier activation patterns by relying on the joint detection of the attack mode and the user activity with the help of a quantum learning network. Stollenwerk *et al.* [377] studied the popular quantum approximate optimization algorithm [378] and its generalization to problems subject to hard constraints [379].

D. Quantum Neural Network

Neural network-based ML has been increasingly recognized as an effective solution to complex problems ranging from image processing to accurate medication. Nevertheless, the exponentially escalating complexity of large-scale many-body networks makes its integration with quantum physics challenging. In the past decade, quantum computing and ML have enjoyed swift advances and have the potential to revolutionize the way information technology is used and implemented. The rapidly developing area of quantum ML may be expected to support the further evolution of quantum computing.

The state-of-the-art ML methods rely on the classical von Neumann computation frameworks and are already extensively employed both in large-scale industrial and academic applications [380]. However, the existing quantum computing architectures are unsuitable for classical deep learning frameworks. A more viable solution is to develop deep-learning algorithms for quantum circuits. Tab. XIII summarizes the key technologies in quantum learning and their applications at a glance.

To elaborate, Tacchino *et al.* [349] provided an overview of the recent literature, with an emphasis on implementing neural networks on quantum platforms. They proposed a novel

approach in which separate quantum nodes rely on the novel technique of variational unsampling policies. In [381], the probability distribution is estimated by sampling the output of a quantum circuit, while relying on a specific initial state. In this context, sampling techniques tend to assume prior knowledge of the unitary operation performed by the quantum circuit and focus either on the output or on the final state. By contrast, the family of unsampling techniques aims for extracting as much information as possible about the unitary operation of a circuit using a polynomially increasing number of outputs, while relying on a given initial state. The authors analyze and validate a host of results gleaned from near-term quantum circuits by leveraging variational quantum unsampling, which belongs to the family of non-linear quantum machine learning schemes. This scheme supports the training and refinement of a QD action to unveil the effect of unknown unitary operations on a given input state.

With the objective of conceiving deep reinforcement learning, Chen *et al.* [350] investigated variational quantum circuits. Mixed quantum-classical computing circuits were employed in the constituent system investigated [382]. This type of quantum circuit has tunable parameters that can be optimized iteratively by a classical computer. It is possible to view the corresponding parameters as artificial neural network coefficients. The robustness to noise and circuit depth adaptations was also demonstrated for variational quantum circuits. Chen *et al.* [350] reshaped classical deep reinforcement learning algorithms, including the functions of experience replay and training networks into variational quantum circuits.

Killoran *et al.* [352] developed a technique for building neural networks based on quantum computers. In quantum ML, a variational quantum circuit relying on a CV framework encrypts quantum data in the continuous-valued space, such as the phases in electromagnetic fields. Their quantum computing networks relied on layered structures having CV parameters. Quantum networks employing both Gaussian and non-Gaussian gates constitute a pair of essential elements in conventional neural networks, namely affine transformations and nonlinear activation functions. Based on the construction of the CV framework, CV quantum neural networks are capable of encrypting strongly nonlinear manipulations and maintaining strict unitarity. Killoran *et al.* [352] also demonstrated how to integrate a classical system into a quantum architecture and developed quantum-based models for several training frameworks, including convolutional, recurrent, and residual models. The Strawberry Fields software platform [383] was used for constructing training experiments. In addition to implementing a fraud detection classifier and a classical quantum auto-encryption system, the experiments demonstrated the generalizability of CV quantum ML architectures.

Mari *et al.* [354] applied the popular transfer learning technique in a mixed neural network having both classical and quantum components. Specifically, they relied on a pre-learned classical system revised and enhanced by a variational quantum circuit. Their proposed method facilitates the processing of high-dimensional data (e.g., pictures) in advance by a classical method and integrates an appropriately selected group of critical characteristics with a quantum operator. A

system-oriented software library, namely PennyLane [384], was used for examining a high-definition image classifier using two distinguishable quantum computing machines provided by IBM [385] and Rigetti [386], respectively.

Inspired by the recent developments in quantum data analyzers, Cong *et al.* [353] examined a quantum circuit inspired by the philosophy of convolutional neural networks (CNNs). The extension of CNNs to the QD is constituted by quantum convolutional neural networks (QCNNs) [353]. By using on the order of $\mathcal{O}(\log(N))$ variational coefficients on N qubits, QCNN enables real-world quantum equipment to be applied effectively. To clearly illustrate the functionalities of QCNN, Cong *et al.* [353] applied them to recognize quantum states in a group of one-dimensional many-body systems and demonstrated that QCNNs are capable of confidently distinguishing quantum states. Furthermore, Cong *et al.* [353] demonstrated that quantum error control methods can be designed using QCNNs to outperform known QD methods. Mitarai *et al.* [356] proposed a new classical-quantum hybrid ML framework, termed quantum circuit learning, for implementing neural networks in near-term, realizable, low-depth quantum circuits. Their solution iteratively refines the circuit parameters based on the input data until the circuits provide the expected outputs.

E. Other Quantum Machine Learning Models

Support vector machines (SVMs) constitute one of the most popular techniques designed for classification tasks widely used in pattern recognition, for example [387]. However, they may become excessively complex in large-scale classification tasks when the feature space is huge [388]. In this context, the quantum computation techniques are capable of enhancing both the traditional deep learning and reinforcement learning models, as well as the generative and discriminative learning models often used for data classification, as discussed below.

Havlicek *et al.* [351] conceived and experimentally implemented a pair of QD techniques on a superconductive processor for supervised learning, which involved constructing either a classifier or an estimator. Their first algorithm, which uses a variational quantum circuit, categorizes data similarly to traditional SVMs by constructing a classifier function in the feature space. The second algorithm, namely a quantum kernel approximator, approximates the kernel function on a quantum computer and achieves the same results as the best classical SVM. Both of these quantum algorithms rely on using the quantum state space as their feature space, which can only be recognized by a quantum computer. Their methods facilitate the implementation of ML on NISQ computers.

Chen *et al.* [357] also attempted to classify data stored in the form of quantum states by training quantum circuits. This is an extension of the well-established quantum state discrimination technique designed to address the specific challenge that it is impossible to discriminate against non-orthogonal quantum states deterministically. A so-called quantum circuit ansatz was designed to perform arbitrary unitary transformations, which was trained to attain maximum generalization capability. The loss function was the average absolute difference between the

desired and measured probabilities of quantum states. The training was conducted using the Adam optimization algorithm [389]. It was shown that quantum circuits can be trained, and quantum data can be discriminated non-deterministically by balancing the errors and the inconclusiveness of classification tasks. This approach is capable of addressing challenges in both quantum ML and quantum computing.

Huggins *et al.* [358] designed a quantum tensor network circuit for processing large numbers of samples and components in real-world data. The geometry of the tensor-network-equivalent quantum circuits was specified, and the parameters of unitary operations were optimized individually for specific ML tasks. By relying on their circuits, quantum ML, including discriminative and generative learning can be implemented in a unified theoretical and algorithmic framework that harnesses both classical and quantum computing. Tests of discriminative and generative tensor network models were carried out based on the MNIST dataset through supervised learning, and the gradient of the loss function was estimated through simultaneous perturbation-based stochastic approximation.

To model the probability distribution of any natural data, Gao *et al.* [359] proposed a quantum generative model (QGM), which uses the probability of entangling many-body states for modeling correlations within the data. QGMs are more generalizable than classical factor graphs, since they constitute quantum realizations of factor graphs. Statistical function divergences between the generative model and the given sample data set can be minimized with the help of the Kullback-Leibler divergence [390]. The QGM offers substantial improvements in representational power in the runtime of learning and the runtime of inference. Furthermore, it is capable of representing almost any factor graph. Zhang *et al.* [355] presented a modulation constellation format identification scheme that utilizes density-based spatial clustering relying on ML. This modulation format identification process was implemented at the receiver of a CVQKD system and demonstrated good identification performance in this specific application.

F. Summary

One of the advantages of quantum computing over classical computing is its ability to provide exponential or even super-exponential acceleration in solving complex computing problems. In this section, we have introduced the relevant research advances in quantum computing and explored the combination of quantum computing and AI. However, quantum computing and communication research has been following relatively independent tracks. Only limited efforts have been invested in their joint design. The lack of research on the joint design of quantum computing and quantum communication stifles further progress in the quantum information field. One of the main limitations of quantum AI is the unavailability of quantum computing hardware. Quantum computers are still in the early stages of development and are not widely available. As a result, it is expensive to perform large-scale quantum computing, thereby limiting the capabilities of quantum AI.

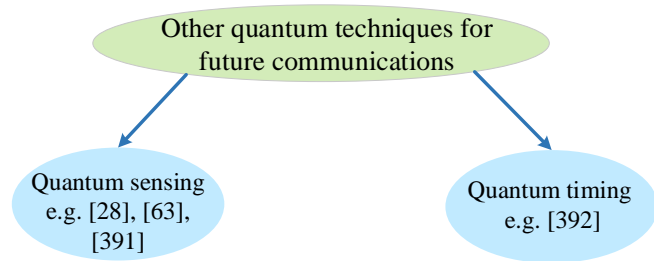

Fig. 25. Other quantum techniques for future communications. The integration of accurate quantum sensing and quantum communication can realize high-quality holographic communication. Quantum timing can provide high timing accuracy and high-precision positioning services for future networks. The combination of quantum sensing and quantum communication can significantly enhance the information security hardware efficiency of the network and obtain an integration gain.

VIII. QUANTUM SENSING AND TIMING FOR FUTURE COMMUNICATIONS

In this section, we briefly discuss quantum sensing as well as quantum timing, and point out the benefits of quantum technologies in these fields, as shown in Fig. 25. ISAC is one of the key technologies for future communications. In the QD, sensing and communication can be beneficially combined, giving birth to numerous new quantum services and enabling future networks. For example, the amalgam of high-resolution quantum sensing and quantum communication is capable of supporting holographic communication for promoting the deep integration of the real physical world and the virtual digital world. Quantum timing is capable of providing excellent timing accuracy and high-precision positioning services for future networks.

An emerging application is quantum remote sensing. In this context, the authors of [63] examined quantum remote sensing, where the client assigns a measurement mission to a distant server relying on a quantum sensor, and the eavesdropper intercepts all the classical information on the server. The authors of [63] compared the information gleaned both by the client and by an eavesdropper when considering the effects of both dephasing and state preparation errors.

Quantum radar, as a specific branch of quantum sensing, will exploit the particle-based nature of light to achieve target detection. In this context, Bourassa *et al.* [391] compared the application of quantum radar and classical radar. As expected, their results demonstrated that the cost of a quantum radar is substantially higher than that of a classical radar. However, the effective SNR of a quantum radar was claimed to be better than that of a classical radar at the same transmit power and bandwidth. Salmanoglu *et al.* [28] described the principle of entanglement conservation, and critical components of the quantum sensors were designed.

Quantum sensing is also useful in time stamp transmission. Dai *et al.* [392] developed a satellite-based quantum-secured time stamp transfer method relying on bidirectional QKD techniques. The authors of [392] investigated both the timestamp transmission of individual photons from a satellite to the terrestrial system, as well as the production of security keys through QKD, and the safe delivery of quantum-ciphered

information. They achieve a QBER of less than 1% and a time stamp transfer accuracy of 30 ps. Based on the Micius quantum satellite, the authors of [392] verified the feasibility of quantum-secured time stamp transfer in sub-nanosecond precision over satellite-to-ground links. The other application scenarios of quantum sensing in future networks include space-air-ground network integration [393], joint communication, navigation, and remote sensing [13], as well as holographic interaction [30]. By jointly designing the timing and sensing, future networks could benefit from precise localization and synchronization [63].

Summary: Quantum sensing and timing are promising directions in the field of quantum information technology. These sensors have the potential to improve the performance of current sensor technologies. However, the relationships, theoretical boundaries, and performance trade-offs between quantum communication, quantum sensing, and quantum computing require substantial further research.

IX. COMMERCIAL LANDSCAPE AND CASE STUDY

Apart from theoretical academic studies and scientific demonstrations, significant progress in developing and commercializing quantum technologies is underway, see Tab. XIV. China, the US, UK, and Canada are among the most active players in this field. While most industrial progress has been made in encryption, attention has also been increasingly drawn to the chip design of quantum systems (see Figs. 26 and 27).

The United States and China started early in the research of quantum communications. Through cooperation with scientific research institutes, the industry carried out a series of field trials in quantum communication networks, leading to the establishment of global quantum communication networks. In addition to its two research and development centers in Hefei and Wuhu, Qasky is a subsidiary of the key quantum information laboratory of the Chinese Academy of Sciences. Additionally, the company has built quantum information research and development platforms, including the quantum security engineering technology research center. The company's technical support team has achieved impressive experimental results. Boaron *et al.* [425] constructed a QKD system. Superconducting single-photon detectors and ultra-low-loss fiber were used to attain a secret key rate of 6.5 bps over a distance of 405 km. In 2018, Liao *et al.* [301] experimented with a long-distance QKD network by using LEO satellites as relays. In this scenario, QKD was performed among three distant locations using the Micius satellite, namely Xinglong and Nanshan in China and Graz in Europe, see Fig. 28.

Before the publication of [410], the longest quantum communication distance on the ground without relaying was around 100 km. In order to extend the distance without using quantum repeaters, researchers constructed a satellite-based QKD network. The network consists of a satellite, and a pair of ground stations located in Nanshan and Delingha in China, respectively. The distance between the two ground stations is 1,120 km. Both ground stations receive polarized-entangled photon pairs generated in the satellite. Yin *et al.* [410] increased the collection efficiency of the photons,

and succeeded in reducing the QBER to 4.5%, which can support a satellite-based QKD link, operating at a secret key rate of 0.12 bps. In [411], a large-scale quantum network was described, which is seen in Fig. 29. This experimental quantum network consists of four quantum metropolitan area networks (QMANs) situated in Beijing, Jinan, Hefei, and Shanghai, plus a long-distance fiber backbone network, and a satellite-to-ground network associated with two ground stations and a quantum communication satellite – the Micius satellite. These two ground stations are 2,600 km apart and the backbone network covers over 2,000 km. This network consists of over 700 fiber QKD links and two satellite-to-ground QKD links. The satellite-to-ground QKD scheme achieved a secret-key rate of 47.8 kbps on average and a peak rate of 462 kbps.

In [412], an investigation of the coexistence of classical data and QKD over fiber at a maximum launch power of 21 dBm over a 66 km fiber backbone was presented. Eight nodes and 800 km of optical fiber were used for the China Unicom backbone loop network in Shandong province, which relied on a decoy-state BB84 encoding system. In [413], successful implementation of an end-to-end “key on-demand” QKD service was demonstrated using SDN.

Summary: In this section, we presented a comprehensive survey of quantum technology companies worldwide, shedding light on their diverse research endeavors. Furthermore, we highlighted some of the field experiments carried out by these companies. Quantum technology companies primarily focus their research efforts on algorithms, cryptography, software development, chip design, and platform development. Additionally, several companies have ventured into field experiments involving quantum communication networks, leveraging collaborative partnerships with scientific research institutions. While quantum technology continues to experience rapid growth, there remains a need to expedite the transformative application of quantum technology. This necessitates the integration of quantum communication, quantum computing, big data, cloud computing, and a range of other cutting-edge technologies in the interest of architecting the Qinternet.

X. CHALLENGES AND OPEN ISSUES OF FUTURE QUANTUM COMMUNICATIONS

Quantum communications have witnessed remarkable advances, yet the integration of quantum technologies into commercial networks to ensure secure communications presents a hitherto unexplored research frontier. Addressing this requires dedicated community efforts. Tab. XV provides an overview of the challenges and open issues that require urgent research attention.

A. Quantum Error Correction

Enhancing the quantum error correction capabilities is crucial for mitigating the deleterious effects of decoherence [12], [110]. Quantum computing faces unique challenges due to the no-cloning theorem, requiring novel techniques for mitigating the errors resulting from interactions with the environment [426]. Existing quantum error correction methods are still unable to clean up all the errors inflicted by the low-fidelity

TABLE XIV

A SUMMARY OF SOME MAJOR QUANTUM COMPANIES, WHERE ✓ INDICATES THAT THE COMPANY IS ENGAGED IN THE CORRESPONDING RESEARCH AREA, AND A BLANK SPACE INDICATES OTHERWISE (“C.A” REFERS TO COMMERCIALY AVAILABLE, AND “U.D” REFERS TO UNDER DEVELOPMENT [394])

Company	Headquarter location	Key research area					Status
		Algorithm	Crypto	Software	Chip	Platform	
ArQit [395]	U.K		✓			✓	C.A
Cambridge Space Technologies [396]	U.K	✓		✓		✓	U.D
Crypto Quantique [397]	U.K				✓		C.A
CryptoNext Security [398]	France	✓	✓				C.A
Entangled Networks [399]	Canada			✓			U.D
EYL [400]	Korea		✓		✓		U.D
ID Quantique [108]	Switzerland	✓	✓			✓	C.A
ISARA [401]	Canada		✓	✓			C.A
KETS Quantum Security [402]	U.K				✓	✓	C.A
Magiq [403]	U.S		✓	✓			C.A
Nu Quantum [404]	U.K	✓			✓		U.D
PQ Solutions [405]	U.K			✓		✓	C.A
PQShield [406]	U.K	✓	✓	✓			U.D
Qabacus [407]	U.S	✓		✓			U.D
Qaisec [408]	Bulgaria	✓	✓	✓			U.D
Qasky [301], [409]–[413]	China			✓	✓		C.A
QEYnet [414]	Canada	✓				✓	U.D
Qike Quantum [415]	China				✓	✓	C.A
QuantiCor Security [416]	Germany	✓	✓				U.D
Quantropi [417]	Canada		✓	✓		✓	C.A
Quantum Bridge Technologies [418]	Canada					✓	U.D
Quantum Trilogy [419]	U.S	✓	✓				C.A
Qubitekk [420]	U.S				✓	✓	U.D
Quintessence Labs [421]	Australia		✓		✓		C.A
QuSecure [422]	U.S		✓	✓			C.A
SpeQtra [423]	Singapore		✓		✓	✓	C.A
VeriQloud [424]	France	✓	✓	✓			C.A

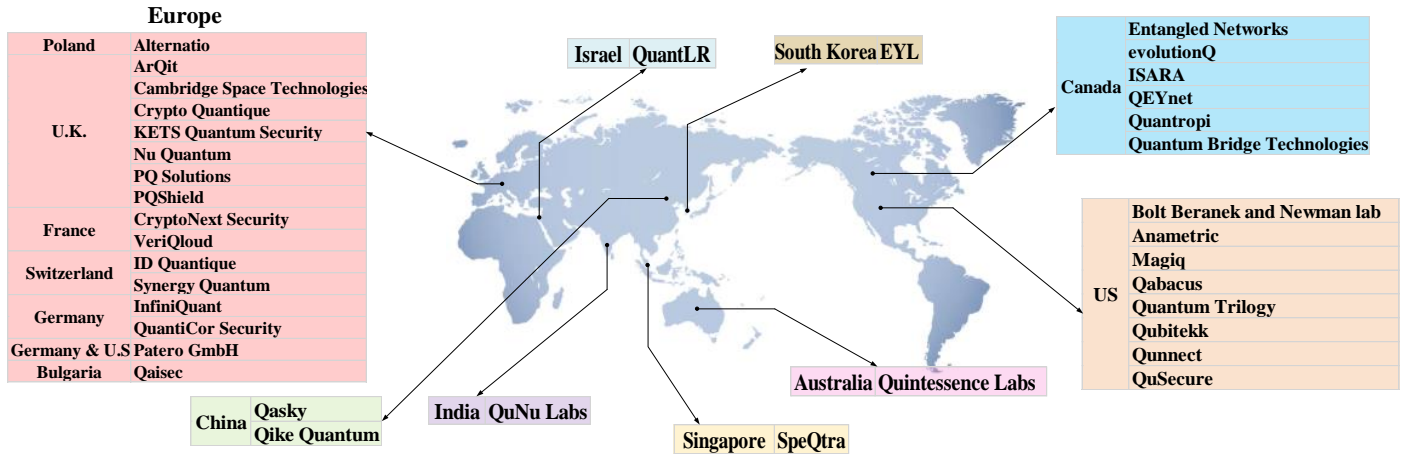

Fig. 26. Company location. Apart from academic and scientific demonstrations, significant progress in developing and commercializing quantum technologies is underway. The US, UK, and Canada are among the biggest and most active players in this field. Quantum communication technology companies have also been established in other countries around the world [394].

TABLE XV
A SUMMARY QUANTUM FUTURE CHALLENGES AND OPEN ISSUES

Quantum enabled future communication Visions	Challenges and open issues
Intelligent Connectivity	<ul style="list-style-type: none"> • The number of qubits in auxiliary entangled quantum codes cannot be freely altered, non-additive quantum codes can only correct local errors, and asymmetric QECCs are too complex to implement (see Sec. X-B); • Developing new methods for quantum error correction; (see Sec. X-B) • Integrate AI techniques for easier and less complex quantum error correction (see Sec. X-B)';
Deep Connectivity	<ul style="list-style-type: none"> • Realizing quantum (entanglement) multiple access and coping with the huge computational complexity of densely connected quantum communication systems (see Sec. X-D); • Developing the necessary hardware and software to make integration of quantum computing and communications a reality (see Sec. X-H);
Holographic Connectivity	<ul style="list-style-type: none"> • Components for THz quantum communications, such as QCLs, modulators, and quantum cascade detectors, are not yet widely available (see Sec. X-C); • High-performance THz detectors have limitations such as a small energy spacing between bound and continuous states and low doping in quantum wells, which reduce their dark current performance and absorption efficiency (see Sec. X-C); • Transferring classical antenna knowledge to the design and fabrication of quantum antennas is challenging (see Sec. X-E); • Solving nonlinear problems, such as designing antenna geometry, interaction strengths, and initial quantum states, is difficult (see Sec. X-E);
Ubiquitous Connectivity	<ul style="list-style-type: none"> • Developing new technologies to extend the entanglement coherence time and reduce the entanglement consumption rate to improve the coverage of space-air-ground integrated network (SAGIN) (see Sec. X-A); • Efficiently generate entangled qubits and assign them to quantum nodes (see Sec. X-A); • The relationships, theoretical boundaries, and performance trade-offs between communication, sensing, and quantum computing need to be further investigated (see Sec. X-F); • Commercial systems and future communication perception may be impacted by privacy and billing schemes (see Sec. X-F); • Rapid construction of quantum channels between high mobility nodes remains a challenge (see Sec. X-G); • To realize the construction of a space quantum communication network, more medium and high-orbit quantum satellites are needed as relays, posing a greater challenge to the acquisition, tracking, and pointing (ATP) tracking system (see Sec. X-G).

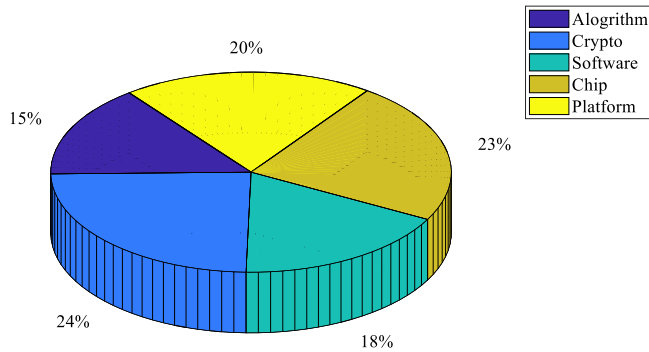

Fig. 27. Key research areas. The areas of research involved in quantum computing companies include algorithms, crypto, software, chips, and platforms. While most industrial progress has been made in encryption, attention has been increasingly drawn to the uptake of chip design for quantum systems.

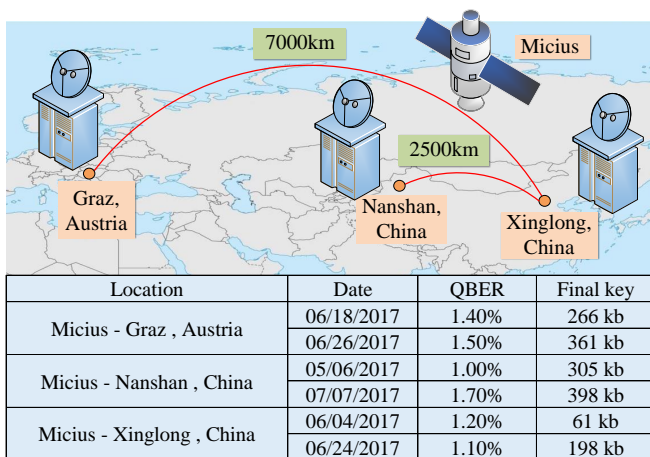

Fig. 28. Illustration of the three cooperating ground stations. Micius satellite is a trusted relay to perform QKD among three distant locations, i.e., Xinglong and Nanshan in China and Graz in Europe [301].

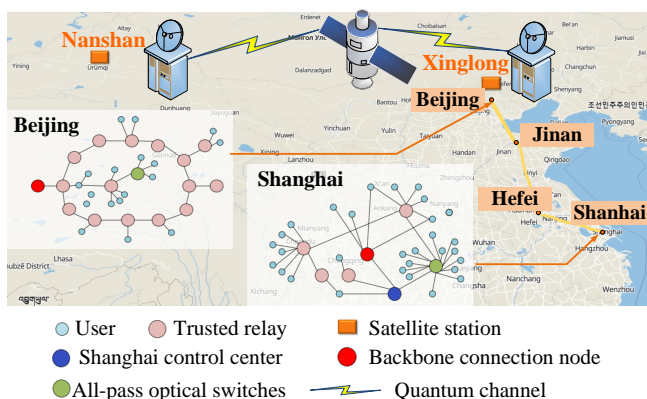

Fig. 29. An illustration of a space-to-ground quantum network. This experimental network consists of four QMANs in Hefei, Shanghai, Jinan, and Beijing. A backbone network communicates these four QMANs and a satellite-to-ground network with two ground stations and a quantum communication satellite—Micius satellite [411].

quantum circuits [427], [428]. Therefore, developing new techniques for efficient quantum error correction is essential.

One of the most popular quantum code design principles hinges on exploiting the so-called symplectic condition, which allows the creation of the quantum coding counterpart of classical codes. However, since these codes treat the bit-flip and phase-flip qubit errors independently, they result in a relatively low coding rate. Future research has to explore the creation of new codes, which dispense with the symplectic condition in the interest of achieving high coding rates and hence requiring fewer qubits. These codes should also be intrinsically amalgamated with quantum error mitigation techniques.

Integrating QD solutions with AI has the potential to revolutionize error correction and enhance the fidelity of quantum computing [429], [430]. This synergy can create more powerful machine learning algorithms in support of quantum cryptography [429], [430].

B. Quantum Device Design for THz Communications

The integration of THz technology with quantum communications holds great potential for enhancing the connectivity and coverage of future networks [1], because at these frequencies inching closer to the photonic domain the particle-like nature of the propagation medium starts to prevail. However, the performance of THz-CVQKD systems is constrained by hostile impairments [203]. The vacuum noise resulting from channel loss reduces the correlation between the communicating parties owing to having a low SNR. To overcome this limitation, a potential THz-CVQKD system requires frontier research in noise suppression techniques, high-gain antennas, efficient detectors, and accurate parameter estimation algorithms [204]. However, high-quality THz components, such as QCLs, modulators, and quantum cascade detectors, are not yet widely available for quantum communications [206].

Inspired by the above-mentioned potential, there have been developments in high-performance THz detectors utilizing quantum wells [431], carbon nanotubes [432], and two-dimensional nanomaterials [433]. However, these detectors face limitations in terms of their dark current performance and absorption efficiency [242], [243]. Furthermore, there have been only theoretical studies on quantum well infrared detectors, but experimental validations are scarce. Addressing these challenges will be crucial for unlocking the full potential of THz technology in quantum communication.

C. Massive Access for Quantum IoT

In recent years, technologies related to IoT have become more mature, and the proliferation of IoT systems has been explosive. This massive access has its own challenges in future quantum communication systems.

Entanglement is a valuable resource in quantum systems and it is of pivotal importance in multi-user systems. Quantum multi-user access and detection techniques can theoretically encode and transmit multiple data streams [130], [434]. This is crucial when there is a massive number of users to support, as already witnessed in 5G systems [435]. However, there are

challenges both in realizing entanglement-based QD multi-access and in coping with the complexity of densely connected quantum communication systems [6]. Accurate detection of quantum states at the receiver also requires the study of new quantum multi-user algorithms such as quantum POVM [436] and square-root measurement (SRM) [437]. By combining these quantum measurement methods with quantum multi-access relying on iterative detection techniques [438] and QD diversity detection technology [212], a combination of existing quantum reception technologies can be realized to support the access of quantum users in the turbulent outdoor channels of the quantum IoT [184].

D. Miniaturization of Quantum Terminals

The miniaturization of quantum devices, e.g., quantum communication chips and quantum antennas, is in the focus of intensive current research. Quantum communication chips provide quantum security that can be used in compact devices such as smartphones, tablets, and smart-watches for improving their communication security [101]. High-gain quantum antennas are required in applications such as far-field sensing [367], [439], quantum communication [440], quantum imaging [441], and energy harvesting [442].

These radical advances require the improvement of antenna configuration and their matching with feeds or detectors, potentially using new metamaterials and nanotechnology. However, the manufacturing and feeding of antennas require delicate processing due to the fragility of entangled states [63]. Transferring the knowledge gathered in the design and fabrication of classical antennas to antennas employed in quantum systems is challenging. Solving problems, such as designing the antenna geometry and the initial quantum states is also a promising future research item.

E. Generation and Distribution of Entangled Qubits

The efficient generation and distribution of entangled qubits is crucial, since they directly impact communication distance. Factors such as entanglement coherence time [443] and entanglement consumption rate [444] play significant roles in determining the effective quantum communication distance. Both a shorter entanglement coherence time and higher entanglement consumption rate result in a reduced communication distance [6], [177]. Therefore, developing novel technologies to extend the entanglement coherence time and reduce the entanglement consumption rate becomes paramount for increasing the quantum communication distance.

F. ATP Technology for Mobile Quantum Communications

The expansion of both air- and space-based networks results in new communication nodes with the objective of improving the network coverage [445]. However, the high mobility of these nodes poses challenges for future quantum communication networks, owing to a plethora of hostile propagation effects [445]. Airborne quantum key distribution technology has the ambitious objective of supporting mobile terminal access in quantum networks [445]. Establishing reliable quantum communication links between UAVs is crucial for various

quantum applications [445]. Ensuring accurate alignment between the transmitter and receiver devices faces challenges due to the non-uniform distribution of electromagnetic fields and geographical variations [446]. Building a space-based quantum communication network harnessing multiple satellites as relays requires advanced ATP systems [447], [448].

G. Integrated Quantum Communications and Sensing

The future quantum ISAC systems exhibit great potential in a variety of fields, including healthcare [449] and automatic driving [450]. Quantum sensors can help detect environmental changes, such as changes in gravity or temperature, despite relying on a modest number of qubits [6]. A particular challenge in integrated quantum sensing and communication is the lack of having unified evaluation criteria. The sensing accuracy may also be affected by measurement error caused by non-ideal hardware factors [6]. The existing communication-oriented channel models do not distinguish between sensing and non-sensing targets. As part of the future integrated quantum sensing and communication scenario [451], it is necessary to distinguish the multi-path echos of perceived targets and clutter, where the existing communication-oriented channel models cannot be directly applied [76]. Furthermore, the relationships, theoretical boundaries, and performance trade-offs between communication, sensing, and quantum computing have to be further investigated.

H. Quantum-Native Computing and Communications

Integrating quantum computing and communications into a joint design gives birth to quantum-native computing and communications, offering new capabilities and applications. It facilitates secure communication by relying on the distribution of quantum states among users and enables the employment of quantum computing algorithms for communication tasks [452], [453]. This fusion has the potential of revolutionizing secure communication networks, distributed computing, and a range of other domains [452], [453]. However, further research is required for exploring its benefits as well as limitations plus the development of the hardware and software necessary for practical implementations [452], [453]. Additionally, integrating quantum computing and communications with other technologies, such as MEC, presents further opportunities for secure and efficient information systems [454].

XI. CLOSING REMARKS

This survey explored the potential benefits of incorporating quantum communications into future systems. By proposing a quantum-native or quantum-by-design architecture, we examined technologies such as QD MIMO, QD relaying, QD resource allocation, QD routing, QD multiplexing, as well as quantum AI and computing. We critically appraised a whole suite of recent research breakthroughs in these areas and adopted a comprehensive system-oriented view to evaluate the feasibility of using quantum communications in future applications.

The survey also identified research gaps and future directions, including the need to extend the entanglement's

coherence time, reduce the entanglement consumption rate, explore new approaches for efficient quantum error correction, develop THz quantum communications devices, and address challenges in the miniaturization of quantum terminals.

Valued colleagues, our hope is that you would feel inspired to join this community effort in exploring this fascinating multi-disciplinary frontier in research, where a plethora of open questions may be solved by scientists from the entire electronics, mathematics, physics, computer science and material science community...

REFERENCES

- [1] X. You, C. Wang, J. Huang, X. Gao, Z. Zhang, M. Wang, Y. Huang, C. Zhang, Y. Jiang, J. Wang, M. Zhu, B. Sheng, D. Wang, Z. Pan, P. Zhu, Y. Yang, Z. Liu, P. Zhang, and L. Hanzo, "Towards 6G wireless communication networks: Vision, enabling technologies, and new paradigm shifts," *Science China-Information Sciences*, vol. 64, no. 1, pp. 1–74, 2021.
- [2] L. Bariah, L. Mohjazi, S. Muhaidat, P. C. Sofotasios, G. K. Kurt, H. Yanikomeroglu, and O. A. Dobre, "A prospective look: Key enabling technologies, applications and open research topics in 6G networks," *IEEE Access*, vol. 8, pp. 174 792–174 820, 2020.
- [3] "ITU Meeting on 6G: Highlights and Key Points," Jul. 4 2022. [Online]. Available: <https://www.6gworld.com/exclusives/itu-meeting-on-6g-highlights-and-key-points/>
- [4] S. Kukliński, L. Tomaszewski, R. Kołakowski, and P. Chemouil, "6G-LEGO: A framework for 6G network slices," *Journal of Communications and Networks*, vol. 23, no. 6, pp. 442–453, 2021.
- [5] V. Ziegler and S. Yrjölä, "How to make 6G a general purpose technology: Prerequisites and value creation paradigm shift," in *Proc. Joint European Conference on Networks and Communications & 6G Summit (EuCNC/6G Summit)*, 2021, pp. 586–591.
- [6] C. Wang and A. Rahman, "Quantum-enabled 6G wireless networks: Opportunities and challenges," *IEEE Wireless Communications*, vol. 29, no. 1, pp. 58–69, 2022.
- [7] Y. Zhao, G. Yu, and H. Xu, "6G mobile communication networks: Vision, challenges, and key technologies," *Scientia Sinica Informationis*, vol. 49, no. 8, pp. 963–987, 2019.
- [8] L. U. Khan, W. Saad, D. Niyato, Z. Han, and C. S. Hong, "Digital-twin-enabled 6G: Vision, architectural trends, and future directions," *IEEE Communications Magazine*, vol. 60, no. 1, pp. 74–80, Jan. 2022.
- [9] H. A. Ahmet Yazar, Seda Dogan Tusha, "6G vision: An ultra-flexible perspective," *ITU Journal on Future and Evolving Technologies*, vol. 1, 2020.
- [10] Z. Wang, Y. Du, K. Wei, K. Han, X. Xu, G. Wei, W. Tong, P. Zhu, J. Ma, J. Wang *et al.*, "Vision, application scenarios, and key technology trends for 6G mobile communications," *Science China Information Sciences*, vol. 65, no. 5, p. 151301, 2022.
- [11] F. Tariq, M. R. Khandaker, K. K. Wong, M. A. Imran, M. Bennis, and M. Debbah, "A speculative study on 6G," *IEEE Wireless Communications*, vol. 27, no. 4, pp. 118–125, 2020.
- [12] Z. Zhang, Y. Xiao, Z. Ma, M. Xiao, and P. Fan, "6G wireless networks: Vision, requirements, architecture, and key technologies," *IEEE Vehicular Technology Magazine*, vol. PP, no. 99, pp. 1–1, 2019.
- [13] M. Z. Chowdhury, M. Shahjalal, S. Ahmed, and Y. M. Jang, "6G wireless communication systems: Applications, requirements, technologies, challenges, and research directions," *IEEE Open Journal of the Communications Society*, vol. 1, pp. 957–975, 2020.
- [14] E. Yaacoub and M.-S. Alouini, "A key 6G challenge and opportunity—connecting the base of the pyramid: A survey on rural connectivity," *Proceedings of the IEEE*, vol. 108, no. 4, pp. 533–582, 2020.
- [15] M. S. Farooq, R. M. Nadir, F. Rustam, S. Hur, Y. Park, and I. Ashraf, "Nested Bee Hive: A conceptual multilayer architecture for 6G in futuristic sustainable smart cities," *Sensors*, vol. 22, no. 16, Aug. 2022.
- [16] Z. Wang, K. Han, J. Jiang, Z. Wei, G. Zhu, Z. Feng, J. Lu, and C. Meng, "Symbiotic sensing and communications towards 6G: Vision, applications, and technology trends," in *Proc. IEEE 94th Vehicular Technology Conference (VTC2021-Fall)*, 2021, pp. 1–5.
- [17] R. Su, M. Zhang, F. Ding, G. Hu, and Q. Qi, "Scenario-based configuration refinement for high-load cellular networks: An operator view," *Applied Sciences*, vol. 12, no. 3, p. 1483, Feb. 2022.
- [18] D. C. Nguyen, M. Ding, P. N. Pathirana, A. Seneviratne, J. Li, D. Niyato, O. Dobre, and H. V. Poor, "6G Internet of Things: A comprehensive survey," *IEEE Internet of Things Journal*, vol. 9, no. 1, pp. 359–383, Jan. 2022.
- [19] C. J. Vaca-Rubio, P. Ramirez-Espinosa, K. Kansanen, Z. Tan, E. De Carvalho, and P. Popovski, "Assessing wireless sensing potential with large intelligent surfaces," *IEEE Open Journal of the Communications Society*, vol. 2, pp. 934–947, 2021.
- [20] K. M. S. Huq, I. E. Otung, and J. Rodriguez, "A study of coverage probability-based energy-efficiency analysis for UAV-aided THz-enabled 6G networks," *IEEE Transactions on Intelligent Transportation Systems*, vol. 24, no. 7, pp. 7404–7411, Jul. 2023.
- [21] N. Hosseinidehaj, Z. Babar, R. Malaney, S. X. Ng, and L. Hanzo, "Satellite-based continuous-variable quantum communications: State-of-the-art and a predictive outlook," *IEEE Communications Surveys & Tutorials*, vol. 21, no. 1, pp. 881–919, 2019.
- [22] A. N. Pinto, N. A. Silva, A. J. Almeida, and N. J. Muga, "Using quantum technologies to improve fiber optic communication systems," *IEEE Communications Magazine*, vol. 51, no. 8, pp. 42–48, 2013.
- [23] L. Hanzo, H. Haas, S. Imre, D. O'Brien, M. Rupp, and L. Gyongyosi, "Prolog to the section on wireless communications technology," *Proceedings of the IEEE*, vol. 100, no. 13, pp. 1849–1852, 2012.
- [24] L. Gyongyosi and S. Imre, "A survey on quantum computing technology," *Computer Science Review*, vol. 31, pp. 51–71, 2019.
- [25] Y. Xia, Q. Zhuang, W. Clark, and Z. Zhang, "Entanglement-based distributed quantum sensing enhanced by quantum relays," in *Proc. Conference on Lasers and Electro-Optics (CLEO)*, 2019, pp. 1–2.
- [26] K. Luo, M. Santandrea, M. Stefszky, J. Sperling, M. Massaro, A. Ferreri, P. R. Sharapova, H. Herrmann, and C. Silberhorn, "Quantum optical coherence: From linear to nonlinear interferometers," in *Proc. Conference on Lasers and Electro-Optics Europe & European Quantum Electronics Conference (CLEO/Europe-EQEC)*, 2021, pp. 1–1.
- [27] G. Puentes and A. Benerji, "Generation of high-order vortex states from two-mode photon-number squeezed states," in *Proc. Photonics North (PN)*, 2022, pp. 1–2.
- [28] A. Salmanoglu, D. Gokcen, and H. S. Gecim, "Entanglement sustainability in quantum radar," *IEEE Journal of Selected Topics in Quantum Electronics*, vol. 26, no. 6, pp. 1–11, 2020.
- [29] M. Swathi and B. Rudra, "Experimental analysis of a quantum encoder in various quantum systems," in *Proc. IEEE 13th Annual Ubiquitous Computing, Electronics & Mobile Communication Conference (UEMCON)*, 2022, pp. 0138–0143.
- [30] A. S. Cacciapuoti, M. Caleffi, R. Van Meter, and L. Hanzo, "When entanglement meets classical communications: Quantum teleportation for the quantum Internet," *IEEE Transactions on Communications*, vol. 68, no. 6, pp. 3808–3833, 2020.
- [31] A. N. Pinto, N. A. Silva, N. J. Muga, A. J. Almeida, and D. F. Pereira, "Quantum communications: An engineering approach," in *Proc. International Conference on Transparent Optical Networks*, 2017, pp. 1–4.
- [32] J. Franson, "Quantum communications," in *Proc. Technical Digest. Summaries of papers presented at the Quantum Electronics and Laser Science Conference. Postconference Technical Digest (IEEE Cat. No. 01CH37172)*, 2001, p. 171.
- [33] C. Pei, C. Zhu, M. Nie, Y. Yan, and D. Quan, *Quantum Communication (Chinese version)*. Xidian University Press, 2013.
- [34] G. Long and X. Liu, "Theoretically efficient high-capacity quantum-key-distribution scheme," *Physical Review A*, vol. 65, no. 3, Mar. 2002.
- [35] Z. Sun, L. Song, Q. Huang, L. Yin, G. Long, J. Lu, and L. Hanzo, "Toward practical quantum secure direct communication: A quantum-memory-free protocol and code design," *IEEE Transactions on Communications*, vol. 68, no. 9, pp. 5778–5792, 2020.
- [36] S. Bahrani, O. Elmabrok, G. C. Lorenzo, M. Ghalaii, and M. Razavi, "Quantum and classical communications on shared infrastructure," in *Proc. 21st International Conference on Transparent Optical Networks (ICTON)*, 2019, pp. 1–2.
- [37] S. K. Borah and S. Bitragunta, "An intelligent link selection mechanism for hybrid classical-quantum communication systems," *IEEE Communications Letters*, vol. 26, no. 2, pp. 301–305, 2022.
- [38] Q. Zhang, F. Xu, Y. Chen, C. Peng, and J. Pan, "Large scale quantum key distribution: Challenges and solutions," *Optics Express*, vol. 26, no. 18, pp. 24 260–24 273, 2018.
- [39] W. Greiner, *Quantum Mechanics: An Introduction*. Springer Science & Business Media, 2000, vol. 1.
- [40] D. Zu, "The classical structure model of single photon and classical point of view with regard to wave-particle duality of photon," *Progress in Electromagnetics Research Letters*, vol. 1, pp. 109–118, 2008.

- [41] L. Hanzo, H. Haas, S. Imre, D. O'Brien, M. Rupp, and L. Gyongyosi, "Wireless myths, realities, and futures: From 3G/4G to optical and quantum wireless," *Proc. IEEE*, vol. 100, no. Special Centennial Issue, pp. 1853–1888, 2012.
- [42] B. A. Sus and B. B. Sus, "Wave-particle nature of radio waves," in *Proc. 13th International Conference on Modern Problems of Radio Engineering, Telecommunications and Computer Science (TCSET)*, 2016, pp. 30–32.
- [43] M. Yu, A. Tang, X. Wang, and C. Han, "Joint scheduling and power allocation for 6G Terahertz mesh networks," in *Proc. International Conference on Computing, Networking and Communications (ICNC)*, 2020, pp. 631–635.
- [44] N. K. Kundu, S. P. Dash, M. R. McKay, and R. K. Mallik, "Channel estimation and secret key rate analysis of MIMO Terahertz quantum key distribution," *IEEE Transactions on Communications*, vol. 70, no. 5, pp. 3350–3363, 2022.
- [45] V. Pushkarev, T. Ostatnický, H. Němec, T. Chlouba, F. Trojánek, P. Malý, M. Zacharias, S. Gutsch, D. Hiller, and P. Kužel, "Quantum behavior of Terahertz photoconductivity in silicon nanocrystals networks," *Physical Review B*, vol. 95, no. 12, p. 125424, Mar. 2017.
- [46] B. Ren, Y. Zhang, T. Niu, H. Ge, and J. Wang, "Simulation modeling and software implementation of optical fiber and space channel in quantum secure communication," in *Proc. IEEE 10th Joint International Information Technology and Artificial Intelligence Conference (ITAIC)*, vol. 10, 2022, pp. 87–94.
- [47] F. Graffitti, C. Morrison, M. Rambach, Z. X. Koong, F. Thorburn, Y. Ma, S. I. Park, J. D. Song, A. K. Kar, A. Fedrizzi, and B. D. Gerardot, "Coherent frequency-conversion of quantum dot photons to the telecommunication C-band for quantum communication applications," in *Proc. Conference on Lasers and Electro-Optics (CLEO)*, 2021, pp. 1–2.
- [48] G. Mélen, T. Vogl, M. Rau, G. Corrielli, A. Crespi, R. Osellame, and H. Weinfurter, "Integrated quantum key distribution sender unit for daily-life implementations," in *Proc. Advances in Photonics of Quantum Computing, Memory, and Communication IX*, vol. 9762, 2016, pp. 31–36.
- [49] V. L. Nguyen, P. C. Lin, B. C. Cheng, R. H. Hwang, and Y. D. Lin, "Security and privacy for 6G: A survey on prospective technologies and challenges," *IEEE Communications Surveys & Tutorials*, vol. 23, no. 4, pp. 2384–2428, 2021.
- [50] X. Huang, J. A. Zhang, R. P. Liu, Y. J. Guo, and L. Hanzo, "Airplane-aided integrated networking for 6G wireless: Will it work?" *IEEE Vehicular Technology Magazine*, vol. 14, no. 3, pp. 84–91, 2019.
- [51] S. Wan, J. Hu, C. Chen, A. Jolfaei, S. Mumtaz, and Q. Pei, "Fair-hierarchical scheduling for diversified services in space, air and ground for 6G-dense Internet of Things," *IEEE Transactions on Network Science and Engineering*, vol. 8, no. 4, pp. 2837–2848, 2021.
- [52] S. Subramani, M. Selvi, A. Kannan, and S. K. Svn, "Review of security methods based on classical cryptography and quantum cryptography," *Cybernetics and Systems*, pp. 1–19, Jan. 2023.
- [53] C. Lee, I. Sohn, and W. Lee, "Eavesdropping detection in BB84 quantum key distribution protocols," *IEEE Transactions on Network and Service Management*, vol. 19, no. 3, pp. 2689–2701, Sep. 2022.
- [54] M. Kamran, T. Malik, and M. M. Khan, "Evaluation of eavesdropping error-rates in higher-dimensional QKD system implemented using dynamic spatial modes," *International Journal of Quantum Information*, vol. 19, no. 06, Sep. 2021.
- [55] G. S. Castro and R. Ramos, V, "Enhancing eavesdropping detection in quantum key distribution using disentropy measure of randomness," *Quantum Information Processing*, vol. 21, no. 2, Feb. 2022.
- [56] D. Pan, K. Li, D. Ruan, S. X. Ng, and L. Hanzo, "Single-photon-memory two-step quantum secure direct communication relying on Einstein-Podolsky-Rosen pairs," *IEEE Access*, vol. 8, pp. 121 146–121 161, 2020.
- [57] J. Liu, Z. Yang, and Z. Wu, "Attacks detection method based on free space quantum secure direct communication," in *Proc. Communications, Signal Processing, and Systems: Proceedings of the 2018 CSPS Volume III: Systems 7th*, 2020, pp. 1109–1116.
- [58] Y. Zhou, Z. Chen, Y. Yang, W. Shi, and Y. Xu, "Three-party quantum secure direct communication protocol with adaptive capacity," *International Journal of Theoretical Physics*, vol. 61, no. 3, Mar. 2022.
- [59] H. Guo, Y. Li, J. Wei, J. Tang, and Y. Cao, "Multi-party deterministic secure quantum communication using d-dimension GHZ state," *Modern Physics Letters B*, vol. 36, no. 24, Aug. 2022.
- [60] S. Jiang, Z. Liu, X. Lou, Z. Fan, S. Wang, and J. Shi, "Efficient verifiable quantum secret sharing schemes via eight-quantum-entangled states," *International Journal of Theoretical Physics*, vol. 60, no. 5, pp. 1757–1766, May 2021.
- [61] Y. Gong, A. Wonfor, J. H. Hunt, I. H. White, and R. Pentyl, V, "Experimental demonstration of confidential communication with quantum security monitoring," *Scientific Reports*, vol. 11, no. 1, Nov. 2021.
- [62] H. Guo, J. Li, J. Liu, N. Tian, and N. Kato, "A survey on space-air-ground-sea integrated network security in 6G," *IEEE Communications Surveys & Tutorials*, vol. 24, no. 1, pp. 53–87, 2022.
- [63] H. Okane, H. Hakoshima, Y. Takeuchi, Y. Seki, and Y. Matsuzaki, "Quantum remote sensing under the effect of dephasing," *Physical Review A*, vol. 104, no. 6, Dec. 2021.
- [64] D. T. Hai, "Network coding in photonicland: Three commandments for future-proof optical core networks," in *Proc. IEEE Microwave Theory and Techniques in Wireless Communications (MTTW)*, 2021, pp. 165–170.
- [65] E. Erdogan, I. Altunbas, G. K. Kurt, M. Bellemare, G. Lamontagne, and H. Yanikomeroğlu, "Site diversity in downlink optical satellite networks through ground station selection," *IEEE Access*, vol. 9, pp. 31 179–31 190, 2021.
- [66] O. Maraqa, A. S. Rajasekaran, H. U. Sokun, S. Al-Ahmadi, H. Yanikomeroğlu, and S. M. Sait, "Energy-efficient coverage enhancement of indoor THz-MISO systems: An FD-NOMA approach," in *Proc. IEEE 32nd Annual International Symposium on Personal, Indoor and Mobile Radio Communications (PIMRC)*, 2021, pp. 483–489.
- [67] N. Fabbri, P. De Natale, and F. S. Cataliotti, "Quantum sensing technologies for defence applications: The project QUANDO," in *Proc. 23rd International Radar Symposium (IRS)*, 2022, pp. 294–299.
- [68] G. Gilbert, M. Hamrick, Y. S. Weinstein, S. P. Pappas, and A. Donadio, "Quantum sensor miniaturization," *IEEE Photonics Technology Letters*, vol. 19, no. 22, pp. 1798–1800, 2007.
- [69] Q. Zhuang, Z. Zhang, and J. H. Shapiro, "Distributed quantum sensing using continuous-variable multipartite entanglement," in *Proc. Conference on Lasers and Electro-Optics (CLEO)*, 2018, pp. 1–2.
- [70] W. Wang, J. Li, R. Wei, and Q. Guo, "Entangled photons based particle-level temporal-spatial matching processing in quantum radar," in *Proc. CIE International Conference on Radar (Radar)*, 2021, pp. 2821–2824.
- [71] D. Luong, B. Balaji, and S. Rajan, "Biomedical sensing using quantum radars based on Josephson parametric amplifiers," in *Proc. International Applied Computational Electromagnetics Society Symposium (ACES)*, 2021, pp. 1–4.
- [72] C. Fang, X. Shi, Q. Liu, F. Lei, and D. Wang, "Scattering environment analysis of quantum radar for the typical 2D target," in *Proc. IEEE MTT-S International Conference on Numerical Electromagnetic and Multiphysics Modeling and Optimization (NEMO)*, 2020, pp. 1–3.
- [73] S. Barzanjeh, S. Pirandola, D. Vitali, and J. M. Fink, "Microwave quantum illumination using a digital receiver," *Science Advances*, vol. 6, no. 19, May 2020.
- [74] F. Liu, C. Masouros, A. P. Petropulu, H. Griffiths, and L. Hanzo, "Joint radar and communication design: Applications, state-of-the-art, and the road ahead," *IEEE Transactions on Communications*, vol. 68, no. 6, pp. 3834–3862, 2020.
- [75] Q. Zhang, H. Sun, Z. Wei, and Z. Feng, "Sensing and communication integrated system for autonomous driving vehicles," in *Proc. IEEE Conference on Computer Communications Workshops (INFOCOM WKSHPS)*, 2020, pp. 1278–1279.
- [76] Z. Feng, Z. Wei, X. Chen, H. Yang, Q. Zhang, and P. Zhang, "Joint communication, sensing, and computation enabled 6G intelligent machine system," *IEEE Network*, vol. 35, no. 6, pp. 34–42, 2021.
- [77] R. Thew and S. Randall, "Strategic research agenda," European Quantum Flagship, Brussels, Düsseldorf, Tech. Rep., Mar. 2020.
- [78] Y. Gu, J. Xu, and M. Zhang, "Quantum information technology for networks use cases: Network aspects of quantum information technologies," ITU-T FG QIT4N, Tech. Rep. D1.2, 2021.
- [79] F. Xu, X. Ma, Q. Zhang, H.-K. Lo, and J.-W. Pan, "Secure quantum key distribution with realistic devices," *Reviews of Modern Physics*, vol. 92, p. 025002, May 2020.
- [80] Y.-W. Cho, G. T. Campbell, J. L. Everett, J. Bernu, D. B. Higginbottom, M. T. Cao, J. Geng, N. P. Robins, P. K. Lam, and B. C. Buchler, "Highly efficient and long-lived optical quantum memory with cold atoms," in *Proc. Conference on Lasers and Electro-Optics (CLEO)*, 2017, pp. 1–2.
- [81] M. Oya, N. Namekat, J. Nishikaw, and S. Inoue, "Quantum secure authentication system experiment using adaptive optics," in *Proc. Conference on Lasers and Electro-Optics Pacific Rim (CLEO-PR)*, 2017, pp. 1–3.
- [82] A. Poppe, M. Gunkel, F. Wissel, P. Schilder, D. Witt, and M. Peev, "Simulation of a telecom-provider driven reference QKD-network," in *Proc. Conference on Lasers and Electro-Optics Europe & European*

- Quantum Electronics Conference (CLEO/Europe-EQEC)*, 2019, pp. 1–1.
- [83] A. Mamiya, K. Tanaka, S. Yokote, M. Sasaki, M. Fujiwara, M. Tanaka, H. Sato, and Y. Katagiri, “Satellite-based QKD for global quantum cryptographic network construction,” in *Proc. IEEE International Conference on Space Optical Systems and Applications (ICSOS)*, 2022, pp. 47–50.
- [84] W. J. Munro and K. Nemoto, “Routing on quantum repeater networks,” in *Proc. Conference on Lasers and Electro-Optics (CLEO)*, 2020, pp. 1–2.
- [85] H. Song, G. Zhang, and H. Yonezawa, “Entanglement generation with Schrödinger kitten states,” in *Proc. Asia Communications and Photonics Conference (ACP)*, 2022, pp. 2135–2136.
- [86] E. A. Sete, W. J. Zeng, and C. T. Rigetti, “A functional architecture for scalable quantum computing,” in *Proc. IEEE International Conference on Rebooting Computing (ICRC)*, 2016, pp. 1–6.
- [87] I. K. Sohn and J. Heo, “An introduction to fault-tolerant quantum computation and its overhead reduction schemes,” in *Proc. 10th International Conference on Ubiquitous and Future Networks (ICUFN)*, 2018, pp. 44–46.
- [88] N. Isailovic, Y. Patel, M. Whitney, and J. Kubiawicz, “Interconnection networks for scalable quantum computers,” in *Proc. 33rd International Symposium on Computer Architecture (ISCA’06)*, 2006, pp. 366–377.
- [89] M. Grassl and M. Roetteler, “Leveraging automorphisms of quantum codes for fault-tolerant quantum computation,” in *Proc. IEEE International Symposium on Information Theory*, 2013, pp. 534–538.
- [90] G. Acampora, M. Grossi, and A. Vitiello, “Genetic algorithms for error mitigation in quantum measurement,” in *Proc. IEEE Congress on Evolutionary Computation (CEC)*, 2021, pp. 1826–1832.
- [91] M. Senekane, M. Mafu, M. Maseli, and B. M. Taelle, “A quantum algorithm for single parity check code,” in *Proc. IEEE Africon*, 2021, pp. 1–6.
- [92] K. N. Smith and M. A. Thornton, “A quantum computational compiler and design tool for technology-specific targets,” in *Proc. ACM/IEEE 46th Annual International Symposium on Computer Architecture (ISCA)*, 2019, pp. 579–588.
- [93] R. Quan, R. Dong, Y. Zhai, T. Liu, and S. Zhang, “Experimental demonstration of femtosecond-level quantum clock synchronization,” in *Proc. Conference on Lasers and Electro-Optics Pacific Rim (CLEO-PR)*, 2018, pp. 1–2.
- [94] A. Casaburi, A. Pizzone, and R. H. Hadfield, “Large area superconducting nanowire single photon detector arrays,” in *Proc. Fotonica AEIT Italian Conference on Photonics Technologies*, 2014, pp. 1–4.
- [95] Y. Israel, R. Tenne, D. Oron, and Y. Silberberg, “Single-photon fiber bundle cameras (SFICAMs) for quantum enhanced superresolution microscopy,” in *Proc. Conference on Lasers and Electro-Optics (CLEO)*, 2017, pp. 1–1.
- [96] G. Slepian, S. Vlasenko, D. Mogilevtsev, and A. Boag, “Quantum radars and lidars: Concepts, realizations, and perspectives,” *IEEE Antennas and Propagation Magazine*, vol. 64, no. 1, pp. 16–26, 2022.
- [97] M. Rossi, D. Mason, J. Chen, Y. Tsaturyan, and A. Schliesser, “Quantum measurement of a mechanical resonator at and below the standard quantum limit,” in *Proc. Conference on Lasers and Electro-Optics Europe & European Quantum Electronics Conference (CLEO/Europe-EQEC)*, 2019, pp. 1–1.
- [98] G. M. Tino, “Gravitational physics with atomic quantum sensors,” in *Proc. Conference on Lasers and Electro-Optics Europe & European Quantum Electronics Conference (CLEO/Europe-EQEC)*, 2019, pp. 1–1.
- [99] A. M. Kasten, W. A. Challener, M. Wang, Y. Lin, L. Tsakalagos, T. F. Miller, and S. A. Zotov, “Optical self-excitation and detection for inertial MEMS sensors,” in *Proc. IEEE International Symposium on Inertial Sensors and Systems (INERTIAL)*, 2017, pp. 66–69.
- [100] M. Pistoia, O. Amer, M. R. Behera, J. A. Dolphin, J. F. Dynes, B. John, P. A. Haigh, Y. Kawakura, D. H. Kramer, J. Lyon *et al.*, “Paving the way towards 800 Gbps quantum-secured optical channel deployment in mission-critical environments,” *arXiv preprint arXiv:2202.07764*, 2022.
- [101] G. Zhang, J. Y. Haw, H. Cai, F. Xu, S. M. Assad, J. F. Fitzsimons, X. Zhou, Y. Zhang, S. Yu, J. Wu, W. Ser, L. C. Kwek, and A. Q. Liu, “An integrated silicon photonic chip platform for continuous-variable quantum key distribution,” *Nature Photonics*, vol. 13, no. 12, pp. 839–842, Dec. 2019.
- [102] G. Burdge, G. Deibner, J. Shaprio, F. Wong, P. Kumar, H. Yuen, M. Vasilyev, N. Stelmakh, Z. Dutton, S. Guha, and J. Habif, “Quantum sensors program,” Harris Corporation, Tech. Rep., 2009.
- [103] M. Everitt, M. J. De C. Henshaw, and V. M. Dwyer, “Quantum systems engineering: A structured approach to accelerating the development of a quantum technology industry,” in *Proc. 18th International Conference on Transparent Optical Networks (ICTON)*, 2016, pp. 1–4.
- [104] M. Li and Y. Liu, “ISO-MAP: Energy-efficient contour mapping in wireless sensor networks,” *IEEE Transactions on Knowledge and Data Engineering*, vol. 22, no. 5, pp. 699–710, 2010.
- [105] X. Liu, Z. Tang, X. An, Y. Huang, Z. Liu, Z. Tao, and J. Pan, “Infrared trace gas sensing with a fast perovskite nano-structure laser photodetector,” *IEEE Photonics Technology Letters*, vol. 35, no. 1, pp. 19–22, 2023.
- [106] Z. Fu, D. Shao, W. Wan, Z. Tan, Z. Zhang, L. Gu, and J. Cao, “Terahertz imaging with a quantum cascade laser and a pixelless imaging chip,” in *Proc. IEEE International Conference on Plasma Science (ICOPS)*, 2020, pp. 531–531.
- [107] N. A. Arshinov and N. G. Butakova, “Vulnerability research of confidential information transmitted over quantum channels in bank infrastructure,” in *Proc. 2019 IEEE Conference of Russian Young Researchers in Electrical and Electronic Engineering (EICoRus)*, 2019, pp. 1726–1730.
- [108] ID Quantique. [Online]. Available: <https://www.idquantique.com>
- [109] P. Botsinis, D. Alanis, Z. Babar, H. V. Nguyen, D. Chandra, S. X. Ng, and L. Hanzo, “Quantum search algorithms for wireless communications,” *IEEE Communications Surveys & Tutorials*, vol. 21, no. 2, pp. 1209–1242, 2019.
- [110] S. J. Nawaz, S. K. Sharma, S. Wyne, M. N. Patwary, and M. Asaduzzaman, “Quantum machine learning for 6G communication networks: State-of-the-art and vision for the future,” *IEEE Access*, pp. 46317–46350, 2019.
- [111] ITU-T Focus Group on Quantum Information Technology for Networks (FG-QIT4N). [Online]. Available: <https://www.itu.int/en/ITU-T/focusgroups/qit4n/Pages/default.aspx>
- [112] M. Li, “Quantum information technology for networks terminology: Network aspects of quantum information technologies,” ITU-T FG QIT4N, Tech. Rep. D1.1, 2021.
- [113] B. Goldstein and B. Lv, “Standardization outlook and technology maturity: Network aspects of quantum information technologies,” ITU-T FG QIT4N, Tech. Rep. D1.4, 2021.
- [114] K. Karunaratne and Y. Jiang, “Quantum information technology for networks terminology: Quantum key distribution network,” ITU-T FG QIT4N, Tech. Rep. D2.1, 2021.
- [115] Z. Ma, T. Frantz, T. Laenger, A. Poppe, and D. Sim, “Quantum information technology for networks use cases: Quantum key distribution network,” ITU-T FG QIT4N, Tech. Rep. D2.2, 2021.
- [116] H. Qin, P. Huang, and H. Wu, “Quantum key distribution network protocols: Quantum layer,” ITU-T FG QIT4N, Tech. Rep. D2.3, 2021.
- [117] H. Wu, H. Qin, P. Huang, K. Kenyoshi, and E. Gayfudtinov, “Quantum key distribution network protocols: Key management layer, QKDN control layer and QKDN management layer,” ITU-T FG QIT4N, Tech. Rep. D2.3, 2021.
- [118] Y. Li, C. Zhao, M. Cheng, J. Lai, Y. Zhou, and Y. Qian, “Quantum key distribution network transport technologies,” ITU-T FG QIT4N, Tech. Rep. D2.4, 2021.
- [119] J. Lai, Z. Ma, and Y. Qian, “Standardization outlook and technology maturity: Quantum key distribution network,” ITU-T FG QIT4N, Tech. Rep. D2.5, 2021.
- [120] M. J. Biercuk and T. M. Stace, “Quantum error correction at the threshold: If technologists don’t get beyond it, quantum computers will never be big,” *IEEE Spectrum*, vol. 59, no. 7, pp. 28–46, 2022.
- [121] P. Namdar, I. A. Calafell, A. Trenti, M. Radonjic, B. Dakic, P. Walther, and L. A. Rozema, “Experimental higher-order interference in quantum mechanics induced by optical nonlinearities,” in *Proc. Conference on Lasers and Electro-Optics Europe & European Quantum Electronics Conference (CLEO/EUROPE-EQEC)*, 2021.
- [122] S. Pirandola, J. Eisert, C. Weedbrook, A. Furusawa, and S. L. Braunstein, “Advances in quantum teleportation,” *Nature Photonics*, vol. 9, no. 10, pp. 641–652, 2015.
- [123] T.-S. Lin, I.-M. Tsai, and S.-Y. Kuo, “Quantum transmission integrity mechanism for indirect communication,” in *Proc. 18th International Conference on Computer Communications and Networks*. IEEE, 2009, pp. 1–6.
- [124] I. Barukčić, “Heisenberg’s uncertainty principle,” *Applied mathematics and applied physics*, vol. 4, no. 5, p. 7, 2016.
- [125] Masato, Koashi, Nobuyuki, and Imoto, “No-cloning theorem of entangled states,” *Physical Review Letters*, vol. 81, no. 19, p. 4264–4267, 1998.
- [126] F. Flamini, N. Spagnolo, and F. Sciarrino, “Photonic quantum information processing: A review,” *Reports on Progress in Physics*, vol. 82, no. 1, p. 016001, Nov. 2018.

- [127] L. Oesterling, D. Hayford, and G. Friend, "Comparison of commercial and next generation quantum key distribution: Technologies for secure communication of information," in *Proc. IEEE Conference on Technologies for Homeland Security (HST)*, 2012, pp. 156–161.
- [128] D. Barral and J. Linares, "Engineering continuous variable and coherent state Bell-like states in a reconfigurable photonic chip," *IEEE Journal of Quantum Electronics*, vol. 53, no. 1, pp. 1–10, 2017.
- [129] A. Pljonkin and P. K. Singh, "The review of the commercial quantum key distribution system," in *Proc. 5th International Conference on Parallel, Distributed and Grid Computing (PDGC)*, 2018, pp. 795–799.
- [130] M. A. Nielsen, I. Chuang, and L. K. Grover, "Quantum computation and quantum information," *American Journal of Physics*, vol. 70, no. 5, pp. 558–559, 2002.
- [131] E. Schrödinger, "Discussion of probability relations between separated systems," *Mathematical Proceedings of the Cambridge Philosophical Society*, vol. 31, no. 4, p. 555–563, 1935.
- [132] A. S. Holevo, "Statistical decision theory for quantum systems," *Journal of Multivariate Analysis*, vol. 3, no. 4, pp. 337–394, 1973.
- [133] R. A. Somaraju, A. Sarlette, and H. Thienpont, "Quantum filtering using POVM measurements," in *Proc. 52nd IEEE Conference on Decision and Control*, 2013, pp. 1259–1264.
- [134] M. Lukac and M. Perkowski, "Projective measurement-based logic synthesis of quantum circuits," in *Proc. 38th International Symposium on Multiple Valued Logic (ismvl 2008)*, 2008, pp. 191–196.
- [135] B. Fortesque and G. Gour, "Reducing the quantum communication cost of quantum secret sharing," *IEEE Transactions on Information Theory*, vol. 58, no. 10, pp. 6659–6666, 2012.
- [136] H. Wang, T. S. Lin, I. M. Tsai, and S. Y. Kuo, "Protocol and applications for sharing quantum private keys," in *Proc. 39th Annual 2005 International Carnahan Conference on Security Technology*, 2005, pp. 204–207.
- [137] T. Shang, R. Chen, and Q. Lei, "Quantum random oracle model for quantum public-key encryption," *IEEE Access*, vol. 7, pp. 130024–130031, 2019.
- [138] E. O. Kiktenko, A. O. Malyshev, M. A. Gavreev, A. A. Bozhedarov, N. O. Pozhar, M. N. Anufriev, and A. K. Fedorov, "Lightweight authentication for quantum key distribution," *IEEE Transactions on Information Theory*, vol. 66, no. 10, pp. 6354–6368, 2020.
- [139] H. Wang, G. Yao, and B. Wang, "A quantum concurrent signature scheme based on the quantum finite automata signature scheme," in *Proc. IEEE 14th International Conference on Anti-counterfeiting, Security, and Identification (ASID)*, 2020, pp. 125–129.
- [140] A. Anderson, "Quantum canonical transformations and integrability: Beyond unitary transformations," *Physics Letters B*, vol. 319, no. 1, pp. 157–162, 1993.
- [141] M. Ban, "Reliability function of quantum dense coding of continuous variables," *Optics Communications*, vol. 189, no. 1, pp. 97–102, 2001.
- [142] Y. Cao, Y. Zhao, Q. Wang, J. Zhang, S. X. Ng, and L. Hanzo, "The evolution of quantum key distribution networks: On the road to the Qinternet," *IEEE Communications Surveys & Tutorials*, vol. 24, no. 2, pp. 839–894, 2022.
- [143] D. Pan, S. X. Ng, D. Ruan, L. Yin, G. Long, and L. Hanzo, "Simultaneous two-way classical communication and measurement-device-independent quantum key distribution with coherent states," *Physical Review A*, vol. 101, no. 1, 2019.
- [144] Z. Yang, M. Zolanvari, and R. Jain, "A survey of important issues in quantum computing and communications," *IEEE Communications Surveys & Tutorials*, vol. 25, no. 2, pp. 1059–1094, 2023.
- [145] D. Chawla and P. S. Mehra, "A survey on quantum computing for Internet of Things security," *Procedia Computer Science*, vol. 218, pp. 2191–2200, 2023.
- [146] M. Casariego, E. Z. Cruzeiro, S. Gherardini, T. Gonzalez-Raya, R. André, G. Frazão, G. Catto, M. Möttönen, D. Datta, K. Viisanen *et al.*, "Propagating quantum microwaves: Towards applications in communication and sensing," *Quantum Science and Technology*, vol. 8, no. 2, p. 023001, Apr. 2023.
- [147] S. R. Hasan, M. Z. Chowdhury, M. Saiani, and Y. M. Jang, "Quantum communication systems: Vision, protocols, applications, and challenges," *IEEE Access*, vol. 11, pp. 15 855–15 877, 2023.
- [148] M. Z. Ali, A. Abohmra, M. Usman, A. Zahid, H. Heidari, M. A. Imran, and Q. H. Abbasi, "Quantum for 6G communication: A perspective," *IET Quantum Communication*, vol. 4, no. 3, pp. 112–124, Sep. 2023.
- [149] H. P. Paudel, S. E. Crawford, Y.-L. Lee, R. A. Shugayev, M. N. Leuenberger, M. Syamlal, P. R. Ohodnicki, P. Lu, D. Mollot, and Y. Duan, "Quantum communication networks for energy applications: Review and perspective," *Advanced Quantum Technologies*, vol. 6, no. 10, Oct. 2023.
- [150] J. Lai, F. Yao, J. Wang, M. Zhang, F. Li, W. Zhao, and H. Zhang, "Application and development of QKD-based quantum secure communication," *Entropy*, vol. 25, no. 4, Apr. 2023.
- [151] A. Purohit, M. Kaur, Z. C. Seskir, M. T. Posner, and A. Venegas-Gomez, "Building a quantum-ready ecosystem," *IET Quantum Communication*, Sep. 2023.
- [152] S. Koudia, A. S. Cacciapuoti, K. Simonov, and M. Caleffi, "How deep the theory of quantum communications goes: Superadditivity, superactivation and causal activation," *IEEE Communications Surveys & Tutorials*, vol. 24, no. 4, pp. 1926–1956, 2022.
- [153] J. Illiano, M. Caleffi, A. Manzalini, and A. S. Cacciapuoti, "Quantum Internet protocol stack: A comprehensive survey," *Computer Networks*, vol. 213, p. 109092, 2022.
- [154] P. Y. Kong, "A review of quantum key distribution protocols in the perspective of smart grid communication security," *IEEE Systems Journal*, vol. 16, no. 1, pp. 41–54, 2022.
- [155] H. Huang, X. Xu, C. Guo, G. Tian, S. Wei, X. Sun, W. Bao, and G. Long, "Near-term quantum computing techniques: Variational quantum algorithms, error mitigation, circuit compilation, benchmarking and classical simulation," *Science China Physics Mechanics & Astronomy*, vol. 66, no. 5, May 2023.
- [156] T. Rastogi, V. Hassija, and V. Saxena, "Quantum communication: Concept, applications, and future outlook," in *Proc. 3th International Conference on Contemporary Computing (IC3-2021)*, 2021, pp. 51–56.
- [157] O. Slattery, X. Tang, L. Ma, T. Gerrits, A. Rahmouni, and S. Bhushan, "The quantum communications and networking project at the information technology laboratory of NIST," in *Proc. IEEE Conference on Communications and Network Security (CNS)*, 2021, pp. 1–6.
- [158] A. Singh, K. Dev, H. Siljak, H. D. Joshi, and M. Magarini, "Quantum Internet—Applications, functionalities, enabling technologies, challenges, and research directions," *IEEE Communications Surveys & Tutorials*, vol. 23, no. 4, pp. 2218–2247, 2021.
- [159] J. Kusyk, S. M. Saeed, and M. U. Uyar, "Survey on quantum circuit compilation for noisy intermediate-scale quantum computers: Artificial intelligence to heuristics," *IEEE Transactions on Quantum Engineering*, vol. 2, pp. 1–16, 2021.
- [160] S. Chakraborty, T. Das, S. Sutradhar, M. Das, and S. Deb, "An analytical review of quantum neural network models and relevant research," in *Proc. 5th International Conference on Communication and Electronics Systems (ICCES)*, 2020, pp. 1395–1400.
- [161] Y. Li, M. Tian, G. Liu, C. Peng, and L. Jiao, "Quantum optimization and quantum learning: A survey," *IEEE Access*, vol. 8, pp. 23 568–23 593, 2020.
- [162] T. M. Fernández-Caramés, "From pre-quantum to post-quantum IoT security: A survey on quantum-resistant cryptosystems for the Internet of Things," *IEEE Internet of Things Journal*, vol. 7, no. 7, pp. 6457–6480, 2020.
- [163] A. Jenet, C. Trefzger, A. Lewis, F. Taucer, L. Van Den Berghe, A. Tüchler, M. Loeffler, and S. Nik, "Standards4Quantum: Making quantum technology ready for industry: Putting science into standards," Joint Research Centre (JRC), Luxembourg, Tech. Rep., 2020.
- [164] H. Zhang, Z. Ji, H. Wang, and W. Wu, "Survey on quantum information security," *China Communications*, vol. 16, no. 10, pp. 1–36, 2019.
- [165] A. Sharma and A. Kumar, "A survey on quantum key distribution," in *Proc. International Conference on Issues and Challenges in Intelligent Computing Techniques (ICICT)*, vol. 1, 2019, pp. 1–4.
- [166] D. Cozzolino, B. Da Lio, D. Bacco, and L. K. Oxenløwe, "High-dimensional quantum communication: Benefits, progress, and future challenges," *Advanced Quantum Technologies*, vol. 2, no. 12, p. 1900038, 2019.
- [167] V. Dunjko and H. J. Briegel, "Machine learning & artificial intelligence in the quantum domain: A review of recent progress," *Reports on Progress in Physics*, vol. 81, no. 7, p. 074001, Jun. 2018.
- [168] P. V. Trinh, A. T. Pham, A. Carrasco-Casado, and M. Toyoshima, "Quantum key distribution over FSO: Current development and future perspectives," in *Proc. Progress in Electromagnetics Research Symposium (PIERS-Toyama)*, 2018, pp. 1672–1679.
- [169] S. Wehner, D. Elkouss, and R. Hanson, "Quantum Internet: A vision for the road ahead," *Science*, vol. 362, no. 6412, 2018.
- [170] L. Gyongyosi, S. Imre, and H. V. Nguyen, "A survey on quantum channel capacities," *IEEE Communications Surveys & Tutorials*, vol. 20, no. 2, pp. 1149–1205, 2018.
- [171] J. Singh and M. Singh, "Evolution in quantum computing," in *Proc. International Conference System Modeling & Advancement in Research Trends (SMART)*, 2016, pp. 267–270.

- [172] R. Qi, Z. Sun, Z. Lin, P. Niu, W. Hao, L. Song, Q. Huang, J. Gao, L. Yin, and G. Long, "Implementation and security analysis of practical quantum secure direct communication," *Light: Science and Applications*, vol. 8, no. 1, pp. 183–190, 2019.
- [173] P. Botsinis, S. X. Ng, and L. Hanzo, "Quantum search algorithms, quantum wireless, and a low-complexity maximum likelihood iterative quantum multi-user detector design," *IEEE Access*, vol. 1, pp. 94–122, 2013.
- [174] P. Botsinis, D. Alanis, Z. Babar, S. X. Ng, and L. Hanzo, "Joint quantum-assisted channel estimation and data detection," *IEEE Access*, vol. 4, pp. 7658–7681, 2019.
- [175] C. B. Peel, B. M. Hochwald, and A. L. Swindlehurst, "A vector-perturbation technique for near-capacity multi-antenna multiuser communication—Part I: Channel inversion and regularization," *IEEE Transactions on Communications*, vol. 53, no. 1, pp. 195–202, 2005.
- [176] Y. Xie, J. Li, R. Malaney, and J. Yuan, "Improved quantum LDPC decoding strategies for the misidentified quantum depolarization channel," in *Proc. 24th European Signal Processing Conference (EUSIPCO)*, 2016, pp. 493–497.
- [177] I. F. Akyildiz, A. Kak, and S. Nie, "6G and beyond: The future of wireless communications systems," *IEEE Access*, vol. 8, pp. 133 995–134 030, 2020.
- [178] K. K. Sharma and V. P. Gerdt, "Entanglement sudden death and birth effects in two qubits maximally entangled mixed states under quantum channels," *International Journal of Theoretical Physics*, vol. 59, no. 2, pp. 403–414, 2020.
- [179] E. Chitambar, I. George, B. Doolittle, and M. Junge, "The communication value of a quantum channel," *IEEE Transactions on Information Theory*, vol. 69, no. 3, pp. 1660–1679, Mar. 2023.
- [180] C. Bennett, P. Shor, J. Smolin, and A. Thapliyal, "Entanglement-assisted capacity of a quantum channel and the reverse Shannon theorem," *IEEE Transactions on Information Theory*, vol. 48, no. 10, pp. 2637–2655, 2002.
- [181] R. Laurenza, S. Tserkis, L. Banchi, S. L. Braunstein, T. C. Ralph, and S. Pirandola, "Tight bounds for private communication over bosonic gaussian channels based on teleportation simulation with optimal finite resources," *Physical Review A*, vol. 100, no. 4, p. 042301, 2019.
- [182] I. B. Djordjevic, "Joint QKD-post-quantum cryptosystems," *IEEE Access*, vol. 8, pp. 154 708–154 712, 2020.
- [183] X. Yu, X. Zhou, C. Xu, L. Wang, D. Shen, and H. Zhou, "A NOMA-based quantum key distribution system over Poisson atmospheric channels," in *Proc. IEEE Global Communications Conference (GLOBECOM)*, 2019, pp. 1–6.
- [184] R. Yuan and J. Cheng, "Free-space optical quantum communications in turbulent channels with receiver diversity," *IEEE Transactions on Communications*, vol. 68, no. 9, pp. 5706–5717, 2020.
- [185] X. Zhou, C. Wei, D. Shen, C. Xu, L. Wang, and X. Yu, "A shot noise limited quantum iterative massive MIMO system over Poisson atmospheric channels," in *Proc. IEEE International Conference on Communications (ICC)*, 2019, pp. 1–6.
- [186] M. Q. Vu, T. V. Pham, N. T. Dang, and A. T. Pham, "Design and performance of relay-assisted satellite free-space optical quantum key distribution systems," *IEEE Access*, vol. 8, pp. 122 498–122 510, 2020.
- [187] X. Y. Wang, T. Y. Wu, C. Dong, S. H. Zhao, and Y. Sun, "Prefixed-threshold real-time selection for correlated turbulent channel model for quantum key distribution with modulating retro-reflectors," *Quantum Information Processing*, vol. 20, no. 1, pp. 1–9, 2021.
- [188] K. Bharti, A. Cervera-Lierta, T. H. Kyaw, T. Haug, S. Alperin-Lea, A. Anand, M. Degroote, H. Heimonen, J. S. Kottmann, T. Menke *et al.*, "Noisy intermediate-scale quantum algorithms," *Reviews of Modern Physics*, vol. 94, p. 015004, Feb. 2022.
- [189] M. Cerezo, A. Arrasmith, R. Babbush, S. C. Benjamin, S. Endo, K. Fujii, J. R. McClean, K. Mitarai, X. Yuan, L. Cincio, and P. J. Coles, "Variational quantum algorithms," *Nature Reviews Physics*, vol. 3, pp. 625–644, 2021.
- [190] Z. Cai, R. Babbush, S. C. Benjamin, S. Endo, W. J. Huggins, Y. Li, J. R. McClean, and T. E. O'Brien, "Quantum error mitigation," *arXiv preprint arXiv:2210.00921*, 2022.
- [191] A. Botea, A. Kishimoto, and R. Marinescu, "On the complexity of quantum circuit compilation," in *Proc. 11th International Symposium on Combinatorial Search*, vol. 9, no. 1, 2018, pp. 138–142.
- [192] J. Eisert, D. Hangleiter, N. Walk, I. Roth, D. Markham, R. Parekh, U. Chabaud, and E. Kashefi, "Quantum certification and benchmarking," *Nature Reviews Physics*, vol. 2, pp. 382–390, 2020.
- [193] C. Guo, Y. Zhao, and H.-L. Huang, "Verifying random quantum circuits with arbitrary geometry using tensor network states algorithm," *Physical Review Letters*, vol. 126, no. 7, p. 070502, Feb. 2021.
- [194] T. M. Fernandez-Carames and P. Fraga-Lamas, "Towards post-quantum blockchain: A review on blockchain cryptography resistant to quantum computing attacks," *IEEE Access*, vol. 8, pp. 21 091–21 116, 2020.
- [195] J. Liu, Y. Yu, K. Li, and L. Gao, "Post-quantum secure ring signatures for security and privacy in the cybertwin-driven 6G," *IEEE Internet of Things Journal*, vol. 8, no. 22, pp. 16 290–16 300, 2021.
- [196] S. Rathore, J. H. Park, and H. Chang, "Deep learning and blockchain-empowered security framework for intelligent 5G-enabled IoT," *IEEE Access*, vol. 9, pp. 90 075–90 083, 2021.
- [197] S. Pirandola, "Composable security for continuous variable quantum key distribution: Trust levels and practical key rates in wired and wireless networks," *Physical Review Research*, vol. 3, p. 043014, Oct. 2021.
- [198] H. Zhao and M.-S. Alouini, "On the transmission probabilities in quantum key distribution systems over FSO links," *IEEE Transactions on Communications*, vol. 69, no. 1, pp. 429–442, 2021.
- [199] S. Zhang, C. Xiao, C. Zhou, X. Wang, J. Yao, H. Zhang, and W. Bao, "Performance analysis of the shore-to-reef atmospheric continuous-variable quantum key distribution," *Applied Sciences*, vol. 9, no. 24, 2019.
- [200] M. Li and T. Wang, "Continuous-variable quantum key distribution over air quantum channel with phase shift," *IEEE Access*, vol. 8, pp. 39 672–39 677, 2020.
- [201] A. Ocampos-Guillén, N. Denisenko, and V. Fernández-Mármol, "Optimising the interconnection of free-space to fibre quantum networks," in *Proc. EPJ Web of Conferences*, vol. 198, 2019, p. 00007.
- [202] C. Liu, C. Zhu, Z. Li, M. Nie, H. Yang, and C. Pei, "Continuous-variable quantum secret sharing based on thermal Terahertz sources in inter-satellite wireless links," *Entropy*, vol. 23, no. 9, 2021.
- [203] Y. He, Y. Mao, H. Zhong, D. Huang, and Y. Guo, "Hybrid linear amplifier-involved detection for continuous variable quantum key distribution with thermal states," *Chinese Physics B*, vol. 29, no. 5, 2020.
- [204] C. Liu, C. Zhu, X. Liu, M. Nie, H. Yang, and C. Pei, "Multicarrier multiplexing continuous-variable quantum key distribution at Terahertz bands under indoor environment and in inter-satellite links communication," *IEEE Photonics Journal*, vol. 13, no. 4, pp. 1–13, 2021.
- [205] C. Ottaviani, M. J. Woolley, M. Erementchouk, J. F. Federici, P. Mazumder, S. Pirandola, and C. Weedbrook, "Terahertz quantum cryptography," *IEEE Journal on Selected Areas in Communications*, vol. 38, no. 3, pp. 483–495, 2020.
- [206] Z. Wang, R. Malaney, and J. Green, "Inter-satellite quantum key distribution at Terahertz frequencies," in *Proc. IEEE International Conference on Communications (ICC)*, 2019, pp. 1–7.
- [207] N. Hosseini-dehaj and R. Malaney, "Quantum entanglement distribution in next-generation wireless communication systems," in *Proc. IEEE 85th Vehicular Technology Conference (VTC Spring)*, 2017, pp. 1–7.
- [208] S. Bahrani, M. Razavi, and J. A. Salehi, "Orthogonal frequency-division multiplexed quantum key distribution," *Journal of Lightwave Technology*, vol. 33, no. 23, pp. 4687–4698, 2015.
- [209] M. Anandan, S. Choudhary, and K. Pradeep Kumar, "OFDM for frequency coded quantum key distribution," in *Proc. International Conference on Fiber Optics and Photonics (PHOTONICS)*, 2012, pp. 1–3.
- [210] U. Pereg, C. Deppe, and H. Boche, "Quantum channel state masking," *IEEE Transactions on Information Theory*, vol. 67, no. 4, pp. 2245–2268, 2021.
- [211] Z. Yang, J. Hou, W. Xu, and M. Shikh-Bahaei, "On fair secure rate maximization for NOMA downlinks using quantum key distribution," in *Proc. IEEE International Conference on Communications Workshops (ICC Workshops)*, 2019, pp. 1–6.
- [212] D. Shen, C. Wei, X. Zhou, L. Wang, and C. Xu, "Photon counting based iterative quantum non-orthogonal multiple access with spatial coupling," in *Proc. IEEE Global Communications Conference (GLOBECOM)*, 2018, pp. 1–6.
- [213] M. Gabay and S. Arnon, "Quantum key distribution by a free-space MIMO system," *Journal of lightwave technology*, vol. 24, no. 8, p. 3114, 2006.
- [214] R. Lin and J. Chen, "Modeling and minimizing spontaneous Raman scattering for QKD secured DWDM networks," *IEEE Communications Letters*, vol. 25, no. 12, pp. 3918–3921, 2021.
- [215] E. E. Moghaddam, H. Beyranvand, and J. A. Salehi, "Resource allocation in space division multiplexed elastic optical networks secured with quantum key distribution," *IEEE Journal on Selected Areas in Communications*, vol. 39, no. 9, pp. 2688–2700, Sep. 2021.
- [216] H. Wang, Y. Zhao, X. Yu, Z. Ma, J. Wang, A. Nag, L. Yi, and J. Zhang, "Protection schemes for key service in optical networks secured by

- quantum key distribution (QKD)," *Journal of Optical Communications and Networking*, vol. 11, no. 3, pp. 67–78, 2019.
- [217] Q. Wang, X. Yu, Q. Zhu, Y. Zhao, and J. Zhang, "Quantum key pool construction and key distribution scheme in multi-domain QKD optical networks (QKD-ON)," in *4th Optics Young Scientist Summit (OYSS 2020)*, vol. 11781. SPIE, 2021, pp. 509–512.
- [218] C. Yang, H. Zhang, and J. Su, "Quantum key distribution network: Optimal secret-key-aware routing method for trust relaying," *China Communications*, vol. 15, no. 2, pp. 33–45, 2018.
- [219] A. S. Holevo, "One-mode quantum Gaussian channels: Structure and quantum capacity," *Problems of Information Transmission*, vol. 43, pp. 1–11, 2007.
- [220] M. Uysal, L. Jing, and M. Yu, "Error rate performance analysis of coded free-space optical links over Gamma-Gamma atmospheric turbulence channels," *IEEE Transactions on Wireless Communications*, vol. 5, no. 6, pp. 1229–1233, 2006.
- [221] A. S. Holevo, "Bounds for the quantity of information transmitted by a quantum communication channel," *Problemy Peredachi Informatsii*, vol. 9, no. 3, pp. 3–11, 1973.
- [222] K. Banaszek, L. Kunz, M. Jachura, and M. Jarzyna, "Quantum limits in optical communications," *Journal of Lightwave Technology*, vol. 38, no. 10, pp. 2741–2754, 2020.
- [223] N. Ramakrishnan, R. Iten, V. B. Scholz, and M. Berta, "Computing quantum channel capacities," *IEEE Transactions on Information Theory*, vol. 67, no. 2, pp. 946–960, Feb. 2021.
- [224] C. H. Bennett, P. W. Shor, J. A. Smolin, and A. V. Thapliyal, "Entanglement-assisted classical capacity of noisy quantum channels," *Physical Review Letters*, vol. 83, no. 15, pp. 3081–3084, 1999.
- [225] O. Alkhazragi, C. Kang, M. Kong, G. Liu, C. Lee, K. Li, H. Zhang, J. M. Wagstaff, F. Alhawaj *et al.*, "7.4-Gbit/s visible-light communication utilizing wavelength-selective semipolar micro-photodetector," *IEEE Photonics Technology Letters*, vol. 32, no. 13, pp. 767–770, 2020.
- [226] X. Shan, S. Zhu, P. Qiu, Z. Qian, R. Lin, Z. Wang, X. Cui, R. Liu, and P. Tian, "Multifunctional ultraviolet-C micro-LED with monolithically integrated photodetector for optical wireless communication," *Journal of Lightwave Technology*, vol. 40, no. 2, pp. 490–498, 2022.
- [227] K. Tanizawa and F. Futami, "Quantum noise-assisted coherent radio-over-fiber cipher system for secure optical fronthaul and microwave wireless links," *Journal of Lightwave Technology*, vol. 38, no. 16, pp. 4244–4249, 2020.
- [228] J. Lan, X. Zeng, S. Ubaid, X. Gao, and S. Zhuang, "Focusing properties of linearly polarized high order hyperbolic-cosine-Gaussian beam with sine-azimuthal wavefront modulated by multiple spiral optical vortices," *Optik*, vol. 183, pp. 65–72, 2019.
- [229] K. Mallick, P. Mandal, B. Dutta, B. Kuiri, S. Santra, R. Mukherjee, and A. S. Patra, "Bidirectional OFDM based MMW/THzW over fiber system for next generation communication," *IEEE Photonics Journal*, vol. 13, no. 4, pp. 1–7, 2021.
- [230] Z. Wang, Q. Tan, Y. Liang, X. Zhou, W. Zhou, and X. Huang, "Active manipulation of the spin and orbital angular momentums in a Terahertz graphene-based hybrid plasmonic waveguide," *Nanomaterials*, vol. 10, no. 12, p. 2436, 2020.
- [231] X. Pang, O. Ozolins, L. Zhang, R. Schatz, A. Udalcovs, X. Yu, G. Jacobsen, S. Popov, J. Chen, and S. Loududoss, "Free-space communications enabled by quantum cascade lasers," *physica status solidi (a)*, vol. 218, no. 3, p. 2000407, 2021.
- [232] S. Nagano, M. Kumagai, H. Ito, Y. Hanado, and T. Ido, "Development of a carbon-monoxide rotational-transition-stabilized 3.1THz quantum cascade laser for Terahertz frequency standard," in *Proc. 45th International Conference on Infrared, Millimeter, and Terahertz Waves (IRMMW-THz)*, 2020, pp. 1–2.
- [233] W. J. Wan, K. Zhou, Z. P. Li, X. Y. Liao, J. C. Cao, and H. Li, "Dispersion and ridge width effect in Terahertz quantum cascade laser combs," in *Proc. International Conference on Infrared, Millimeter, and Terahertz Waves (IRMMW-THz)*, 2019, pp. 1–2.
- [234] S. J. Kindness, N. W. Almond, W. Michailow, B. Wei, L. A. Jakob, K. Delfanzari, P. Braeuninger-Weimer, S. Hofmann, H. E. Beere, D. A. Ritchie, and R. Degl'Innocenti, "Graphene-integrated metamaterial device for all-electrical polarization control of Terahertz quantum cascade lasers," *ACS Photonics*, vol. 6, no. 6, pp. 1547–1555, Jun. 2019.
- [235] F. Wang, V. Pistore, M. Riesch, H. Nong, P.-B. Vigneron, R. Colombelli, O. Parillaud, J. Mangeney, J. Tignon, C. Jirauschek *et al.*, "Ultrafast response of harmonic modelocked THz lasers," *Light: Science & Applications*, vol. 9, no. 1, p. 51, 2020.
- [236] E. A. A. Pogna, M. Asgari, V. Zannier, L. Sorba, L. Vitiello, and M. S. Vitiello, "Unveiling the detection dynamics of semiconductor nanowire photodetectors by Terahertz near-field nanoscopy," *Light: Science & Applications*, vol. 9, no. 189, p. 12, 2020.
- [237] L. Viti, D. G. Purdie, A. Lombardo, A. C. Ferrari, and M. S. Vitiello, "HBN-encapsulated, graphene-based, room-temperature Terahertz receivers, with high speed and low noise," *Nano Letters*, vol. 20, no. 5, pp. 3169–3177, 2020.
- [238] M. Asgari, D. Coquillat, G. Menichetti, V. Zannier, N. Dyakonova, W. Knap, L. Sorba, L. Viti, and M. Serena Vitiello, "Highly sensitive photodetectors at 0.6 THz based on quantum dot single electron transistors," in *Proc. 46th International Conference on Infrared, Millimeter and Terahertz Waves (IRMMW-THz)*, 2021, pp. 1–2.
- [239] T. Liu, Y. Huang, Q. Wei, K. Liu, X. Duan, and X. Ren, "Optimized uni-traveling carrier photodiode and mushroom-mesa structure for high-power and sub-Terahertz bandwidth under zero-and low-bias operation," *Journal of Physics Communications*, vol. 3, no. 9, p. 095004, 2019.
- [240] M. Asgari, D. Coquillat, G. Menichetti, V. Zannier, N. Diakonova, W. Knap, L. Sorba, L. Viti, and M. S. Vitiello, "Quantum-dot single-electron transistors as thermoelectric quantum detectors at Terahertz frequencies," *Nano Letters*, vol. 21, no. 20, pp. 8587–8594, 2021.
- [241] A. E. Yachmenev, R. A. Khabibullin, and D. S. Ponomarev, "Recent advances in THz detectors based on semiconductor structures with quantum confinement: A review," *Journal of Physics D: Applied Physics*, vol. 55, no. 19, p. 193001, 2022.
- [242] Z. Zhang, Z. Fu, C. Wang, and J. Cao, "Research on Terahertz quantum well photodetector," *Journal of Infrared and Millimeter Waves*, vol. 41, no. 1, pp. 103–109, 2022.
- [243] D. Shao, Z. Fu, Z. Tan, C. Wang, F. Qiu, L. Gu, W. Wan, and J. Cao, "Research progress on terahertz quantum-well photodetector and its application," *Frontiers in Physics*, vol. 9, p. 581, 2021.
- [244] L. Viti, A. R. Cadore, X. Yang, A. Vorobiev, J. E. Muench, K. Watanabe, T. Taniguchi, J. Stake, A. C. Ferrari, and M. S. Vitiello, "Thermoelectric graphene photodetectors with sub-nanosecond response times at Terahertz frequencies," *Nanophotonics*, vol. 10, no. 1, pp. 89–98, 2020.
- [245] C. Zheng, G. Wang, J. Li, J. Li, S. Wang, H. Zhao, M. Li, Z. Yue, Y. Zhang, Y. Zhang, and J. Yao, "All-dielectric metasurface for manipulating the superpositions of orbital angular momentum via spin-decoupling," *Advanced Optical Materials*, vol. 9, no. 10, p. 2002007, May 2021.
- [246] W. Huang, X. Hao, Y. Cheng, S. Yin, J. Han, and W. Zhang, "Broadband Terahertz half-wave plate with multi-layered metamaterials designed via quantum engineering," *Journal of Lightwave Technology*, vol. 39, no. 24, pp. 7925–7929, 2021.
- [247] X. Chen, H. Wang, H. Liu, C. Wang, G. Wei, C. Fang, H. Wang, C. Geng, S. Liu, P. Li, H. Yu, W. Zhao, J. Miao, Y. Li, L. Wang, T. Nie, J. Zhao, and X. Wu, "Generation and control of Terahertz spin currents in topology-induced 2D ferromagnetic Fe_3GeTe_2 – Bi_2Te_3 heterostructures," *Advanced Materials*, vol. 34, no. 9, p. 2106172, 2022.
- [248] F. Yue, V. Aglieri, R. Piccoli, R. Macaluso, A. Toma, R. Morandotti, and L. Razzari, "Highly sensitive polarization rotation measurement through a high-order vector beam generated by a metasurface," *Advanced Materials Technologies*, vol. 5, no. 5, p. 1901008, May 2020.
- [249] X. Zang, Y. Zhu, C. Mao, W. Xu, H. Ding, J. Xie, Q. Cheng, L. Chen, Y. Peng, Q. Hu, M. Gu, and S. Zhuang, "Manipulating Terahertz plasmonic vortex based on geometric and dynamic phase," *Advanced Optical Materials*, vol. 7, no. 3, p. 1801328, 2019.
- [250] G. Y. Slepian, S. Vlasenko, and D. Mogilevtsev, "Quantum antennas," *Advanced Quantum Technologies*, vol. 3, no. 4, p. 1900120, 2020.
- [251] X. Liao, J. Cao, and H. Li, "Research progress of Terahertz semiconductor optical frequency combs," *Acta Physica Sinica*, vol. 69, no. 18, p. 189501, 2020.
- [252] V. P. Georgiev, A. Sengupta, P. Maciazek, O. Badami, and A. Asenov, "Simulation of gated GaAs-AlGaAs resonant tunneling diodes for tunable Terahertz communication applications," in *Proc. International Conference on Simulation of Semiconductor Processes and Devices (SISPAD)*, 2020, pp. 241–244.
- [253] Q. Tareq, A. Ragheb, M. Esmail, S. Alshebeili, and M. Z. M. Khan, "Investigation of InAs/InP quantum-dash laser as a source in 28 GHz MMW wireless QPSK transmission," in *Proc. IEEE 6th Optoelectronics Global Conference (OGC)*, 2021, pp. 61–62.
- [254] Q. Tareq, E. Alkhazraji, A. Ragheb, M. Esmail, H. Fathallah, S. Alshebeili, and M. Z. M. Khan, "Tunable 28-60 GHz millimeter wave signal generation using L-band quantum-dash laser," in *Proc. 14th Pacific Rim Conference on Lasers and Electro-Optics (CLEO PR 2020)*, 2020, pp. 1–3.

- [255] P. F. Hopkins, J. A. Brevik, M. Castellanos-Beltran, C. A. Donnelly, N. E. Flowers-Jacobs, A. E. Fox, D. Olaya, P. D. Dresselhaus, and S. P. Benz, "RF waveform synthesizers with quantum-based voltage accuracy for communications metrology," *IEEE Transactions on Applied Superconductivity*, vol. 29, no. 5, pp. 1–5, 2019.
- [256] L. Liu, Y. Liu, X.-Z. Gao, and X. Zhang, "Flexible ultra-wide electro-optic frequency combs for a high-capacity tunable 5G+ millimeter-wave frequency synthesizer," *Applied Sciences*, vol. 11, no. 22, p. 10742, 2021.
- [257] M. Huang, Y. Chen, P. Peng, H. Wang, and G. Chang, "A full field-of-view self-steering beamformer for 5G mm-wave fiber-wireless mobile fronthaul," *Journal of Lightwave Technology*, vol. 38, no. 6, pp. 1221–1229, 2020.
- [258] Q. Tareq, A. Ragheb, E. Alkhazraji, M. Esmail, S. Alshebeili, and M. Khan, "Hybrid 28 GHz MMW over fiber-wireless QPSK transmission system based on mid L-band external injection-locked quantum-dash laser comb source," *Optical Fiber Technology*, vol. 64, p. 102553, 2021.
- [259] Q. Tareq, A. M. Ragheb, M. A. Esmail, S. A. Alshebeili, and M. Z. M. Khan, "Performance of injection-locked quantum-dash MMW source under clear and dusty weather conditions," *IEEE Photonics Journal*, vol. 13, no. 3, pp. 1–9, 2021.
- [260] H. Zhang, M. Xu, Z. Jia, L. A. Campos, Z. Lu, C.-Y. Song, P. Barrios, M. Rahim, P. Zhao, and P. J. Poole, "Quantum dot coherent comb laser source for converged optical-wireless access networks," *IEEE Photonics Journal*, vol. 13, no. 3, pp. 1–9, 2021.
- [261] Q. Tareq, A. M. Ragheb, M. A. Esmail, S. Alshebeili, and M. Z. M. Khan, "2 Gbit/s QPSK wireless transmission system with injection-locked quantum-dash laser 28 GHz MMW source at 1610 nm," in *Proc. Conference on Lasers and Electro-Optics Europe & European Quantum Electronics Conference (CLEO/Europe-EQEC)*, 2021, pp. 1–1.
- [262] F. Alimohammadi, R. Yadipour, K. Abbasian, and H. Baghban, "THz-assisted instantaneous gain switching in quantum dot semiconductor optical amplifiers," *IEEE Photonics Technology Letters*, vol. 27, no. 3, pp. 288–291, 2015.
- [263] H. J. Song and T. Nagatsuma, "Present and future of Terahertz communications," *IEEE Transactions on Terahertz Science & Technology*, vol. 1, no. 1, pp. 256–263, 2011.
- [264] R. Singh, "Silicon THz topological photonics for 6G communications," in *Proc. 47th International Conference on Infrared, Millimeter and Terahertz Waves (IRMMW-THz)*, 2022, pp. 1–1.
- [265] J. C. Balzer, C. J. Saraceno, M. Koch, P. Kaurav, U. R. Pfeiffer, W. Withayachumnankul, T. Kürner, A. Stöhr, M. El-Absi, A. A.-H. Abbas, T. Kaiser, and A. Czyliwlik, "THz systems exploiting photonics and communications technologies," *IEEE Journal of Microwaves*, vol. 3, no. 1, pp. 268–288, 2023.
- [266] Y. Cao, Y. Zhao, J. Zhang, Q. Wang, D. Niyato, and L. Hanzo, "From single-protocol to large-scale multi-protocol quantum networks," *IEEE Network*, vol. 36, no. 5, pp. 14–22, 2022.
- [267] H. Elayan, O. Amin, B. Shihada, R. M. Shubair, and M. S. Alouini, "Terahertz band: The last piece of RF spectrum puzzle for communication systems," *IEEE Open Journal of the Communications Society*, vol. 1, pp. 1–32, 2020.
- [268] T. S. Rappaport, Y. Xing, O. Kanhere, S. Ju, A. Madanayake, S. Mandal, A. Alkhateeb, and G. C. Trichopoulos, "Wireless communications and applications above 100 GHz: Opportunities and challenges for 6G and beyond," *IEEE Access*, vol. 7, pp. 78 729–78 757, 2019.
- [269] N. K. Kundu, S. P. Dash, M. R. McKay, and R. K. Mallik, "MIMO Terahertz quantum key distribution," *IEEE Communications Letters*, vol. 25, no. 10, pp. 3345–3349, 2021.
- [270] K. Senthoo and P. K. Sarvepalli, "Theory of communication efficient quantum secret sharing," *IEEE Transactions on Information Theory*, vol. 68, no. 5, pp. 3164–3186, 2022.
- [271] I. B. Djordjevic, "Integrated optics modules based proposal for quantum information processing, teleportation, QKD, and quantum error correction employing photon angular momentum," *IEEE Photonics Journal*, vol. 8, no. 1, pp. 1–12, 2016.
- [272] X. Cai, "Photonic integrated devices for exploiting the orbital angular momentum of light in optical communications," in *Progress in Electromagnetic Research Symposium (PIERS)*, 2016, pp. 3164–3164.
- [273] Z. Lin, X. Pan, J. Yao, Y. Wu, Z. Wang, D. Zhang, C. Ye, S. Xu, F. Yang, and X. Wang, "Characterization of orbital angular momentum applying single-sensor compressive imaging based on a microwave spatial wave modulator," *IEEE Transactions on Antennas and Propagation*, vol. 69, no. 10, pp. 6870–6880, 2021.
- [274] M. Tsubouchi, K. Nagashima, F. Yoshida, Y. Ochi, and M. Maruyama, "Compact device for intense THz light generation: Contact grating with Fabry-Perot resonator," in *Proc. 41st International Conference on Infrared, Millimeter, and Terahertz waves (IRMMW-THz)*, 2016, pp. 1–2.
- [275] M. Razavi, "Multiple-access quantum key distribution networks," *IEEE Transactions on Communications*, vol. 60, no. 10, pp. 3071–3079, 2012.
- [276] M. Rezaei and J. A. Salehi, "Quantum CDMA communication systems," *IEEE Transactions on Information Theory*, vol. 67, no. 8, pp. 5526–5547, 2021.
- [277] V. Sharma and S. Banerjee, "Quantum communication using code division multiple access network," *Optical and Quantum Electronics*, vol. 52, no. 8, pp. 1–22, 2020.
- [278] R. Ursin, F. Tiefenbacher, T. Schmitt-Manderbach, H. Weier, and A. Zeilinger, "Entanglement-based quantum communication over 144 km," *Nature Physics*, vol. 3, no. 7, pp. 481–486, 2007.
- [279] C. Weedbrook, S. Pirandola, and T. C. Ralph, "Continuous-variable quantum key distribution using thermal states," *Physical Review A*, vol. 86, no. 2, pp. 94–101, 2011.
- [280] F. E. Becerra, J. Fan, G. Baumgartner, J. Goldhar, J. T. Kosloski, and A. Migdall, "Experimental demonstration of a receiver beating the standard quantum limit for multiple nonorthogonal state discrimination," *Nature Photonics*, vol. 7, no. 2, pp. 147–152, Feb. 2013.
- [281] C. W. Helstrom, "Quantum detection and estimation theory," *Journal of Statistical Physics*, vol. 1, pp. 231–252, 1969.
- [282] C. Wei, X. Zhou, L. Wang, P. Tian, and L. Hanzo, "Soft iterative quantum receivers approaching the Helstrom limit using realistic quantum devices," *IEEE Access*, vol. 6, pp. 10 197–10 207, 2018.
- [283] Z. Xu, W. Liu, Z. Wang, and L. Hanzo, "Petahertz communication: Harmonizing optical spectra for wireless communications," *Digital Communications and Networks*, vol. 7, no. 4, pp. 605–614, 2021.
- [284] K. Li, Y. Zuo, and B. Zhu, "Suppressing the errors due to mode mismatch for M -ary PSK quantum receivers using photon-number-resolving detector," *IEEE Photonics Technology Letters*, vol. 25, no. 22, pp. 2182–2184, 2013.
- [285] Y. Zuo, K. Li, and B. Zhu, "16-QAM quantum receiver with hybrid structure outperforming the standard quantum limit," *arXiv preprint arXiv:1412.4486*, 2014.
- [286] L. Yang, J. Wu, Z. Lin, L. Yin, and G. Long, "Quantum secure direct communication with entanglement source and single-photon measurement," *Science China Physics, Mechanics & Astronomy*, vol. 63, no. 11, pp. 1–8, 2020.
- [287] S. Harraz, S. Cong, and K. Li, "Two-qubit state recovery from amplitude damping based on weak measurement. eprint," *arXiv preprint arXiv:1808.03094*, 2018.
- [288] S. Harraz and S. Cong, " N -qubit state protection against amplitude damping by quantum feed-forward control and its reversal," *IEEE Journal of Selected Topics in Quantum Electronics*, vol. 26, no. 3, pp. 1–8, 2020.
- [289] A. U. Rahman, S. Haddadi, M. R. Pourkarimi, and M. Ghominejad, "Fidelity of quantum states in a correlated dephasing channel," *Laser Physics Letters*, vol. 19, no. 3, p. 035204, 2022.
- [290] D. Singh, S. Kumar, and B. K. Behera, "Complexity analysis of quantum teleportation via different entangled channels in the presence of noise," *arXiv preprint arXiv:2108.02641*, 2021.
- [291] W. C. Lindsey, "Transmission of classical information over noisy quantum channels—A spectrum approach," *IEEE Journal on Selected Areas in Communications*, vol. 38, no. 3, pp. 427–438, 2020.
- [292] R. F. Werner and A. S. Holevo, "Counterexample to an additivity conjecture for output purity of quantum channels," *Journal of Mathematical Physics*, vol. 43, no. 9, pp. 4353–4357, 2002.
- [293] D. Leung and W. Matthews, "On the power of PPT-preserving and non-signalling codes," *IEEE Transactions on Information Theory*, vol. 61, no. 8, pp. 4486–4499, 2014.
- [294] Y. Yang, C. Geng, F. Li, G. Huang, and X. Li, "Multi-aperture all-fiber active coherent beam combining for free-space optical communication receivers," *Optics Express*, vol. 25, no. 22, p. 27519, 2017.
- [295] M. Takeoka and M. Sasaki, "Discrimination of the binary coherent signal: Gaussian-operation limit and simple non-Gaussian near-optimal receivers," *Physical Review A*, vol. 78, no. 2, pp. 3674–3690, 2007.
- [296] N. C. Huber, "Modeling the bit error rate for accessing hybrid: Quantum and classical networks in scenarios of the Internet of Things in middle-size smart cities," in *Proc. IEEE Biennial Congress of Argentina (ARGENCON)*, 2018, pp. 1–4.

- [297] X. Zhou, D. Zhang, R. Zhang, and L. Hanzo, "A photon-counting spatial-diversity-and-multiplexing MIMO scheme for Poisson atmospheric channels relying on Q -ary PPM," *Optics express*, vol. 20, pp. 26 379–93, 11 2012.
- [298] D. Huang, Y. Zhao, T. Yang, S. Rahman, X. Yu, X. He, and J. Zhang, "Quantum key distribution over double-layer quantum satellite networks," *IEEE Access*, vol. 8, pp. 16 087–16 098, 2020.
- [299] S. Pirandola, "Bounds for multi-end communication over quantum networks," *Quantum Science and Technology*, vol. 4, no. 4, pp. 045 006–, 2019.
- [300] Y. Wang, Y. Zhao, W. Chen, K. Dong, X. Yu, and J. Zhang, "Routing and key resource allocation in SDN-based quantum satellite networks," in *Proc. International Wireless Communications and Mobile Computing (IWCMC)*, Limassol, Cyprus, 2020, pp. 2016–2021.
- [301] S. Liao, W. Cai, J. Handsteiner, B. Liu, J. Yin, L. Zhang, D. Rauch, M. Fink, J. Ren, W. Liu *et al.*, "Satellite-relayed intercontinental quantum network," *Physical Review Letters*, vol. 120, no. 3, 2018.
- [302] S. Pirandola, "End-to-end capacities of a quantum communication network," *Communications Physics*, vol. 2, no. 1, p. 51, 2019.
- [303] R. Laurenza and S. Pirandola, "General bounds for sender-receiver capacities in multipoint quantum communications," *Physical Review A*, vol. 96, p. 032318, Sep. 2017.
- [304] D. Ding, H. Gharibyan, P. Hayden, and M. Walter, "A quantum multipartite packing lemma and the relay channel," *IEEE Transactions on Information Theory*, vol. 66, no. 6, pp. 3500–3519, 2019.
- [305] T. M. Cover and A. Gamal, "Capacity theorems for the relay channel," *IEEE Transactions on Information Theory*, vol. 25, no. 5, pp. 572–584, 1979.
- [306] X. Ai, R. Malaney, and S. X. Ng, "Quantum key reconciliation for satellite-based communications," in *Proc. IEEE Global Communications Conference (GLOBECOM)*, 2018, pp. 1–6.
- [307] X. Yu, S. Li, Y. Zhao, Y. Cao, A. Nag, and J. Zhang, "Routing, core and wavelength allocation in multi-core-fiber-based quantum-key-distribution-enabled optical networks," *IEEE Access*, vol. 9, pp. 99 842–99 852, 2021.
- [308] Y. Cao, Y. Zhao, R. Lin, X. Yu, J. Zhang, and J. Chen, "Multi-tenant secret-key assignment over quantum key distribution networks," *Optics Express*, vol. 27, no. 3, pp. 2544–2561, 2019.
- [309] R. Wang, R. S. Tessinari, E. Hugues-Salas, A. Bravalheri, N. Uniyal, A. S. Muqaddas, R. S. Guimaraes, T. Diallo, S. Moazzeni, Q. Wang *et al.*, "End-to-end quantum secured inter-domain 5G service orchestration over dynamically switched flex-grid optical networks enabled by a q-ROADM," *Journal of Lightwave Technology*, vol. 38, no. 1, pp. 139–149, 2019.
- [310] Y. Zhao, Y. Cao, W. Wang, H. Wang, X. Yu, J. Zhang, M. Tornatore, Y. Wu, and B. Mukherjee, "Resource allocation in optical networks secured by quantum key distribution," *IEEE Communications Magazine*, vol. 56, no. 8, pp. 130–137, 2018.
- [311] K. A. Patel, J. F. Dynes, M. Lucamarini, I. Choi, A. W. Sharpe, Z. L. Yuan, R. V. Penty, and A. J. Shields, "Quantum key distribution for 10 Gb/s dense wavelength division multiplexing networks," *Applied Physics Letters*, vol. 104, no. 5, pp. 175–179, 2014.
- [312] M. Ureña, I. Gasulla, F. J. Fraile, and J. Capmany, "Modeling optical fiber space division multiplexed quantum key distribution systems," *Optics Express*, vol. 27, no. 5, pp. 7047–7063, 2019.
- [313] R. Lin, A. Udalcovs, O. Ozolins, X. Pang, L. Gan, M. Tang, S. Fu, S. Popov, T. F. Da Silva, G. B. Xavier *et al.*, "Telecommunication compatibility evaluation for co-existing quantum key distribution in homogenous multicore fiber," *IEEE Access*, vol. 8, pp. 78 836–78 846, 2020.
- [314] C. Cai, Y. Sun, Y. Zhang, P. Zhang, J. Niu, and Y. Ji, "Experimental wavelength-space division multiplexing of quantum key distribution with classical optical communication over multicore fiber," *Optics express*, vol. 27, no. 4, pp. 5125–5135, 2019.
- [315] T. A. Eriksson, T. Hirano, B. J. Puttnam, G. Rademacher, R. S. Luís, M. Fujiwara, R. Namiki, Y. Awaji, M. Takeoka, N. Wada *et al.*, "Wavelength division multiplexing of continuous variable quantum key distribution and 18.3 Tbit/s data channels," *Communications Physics*, vol. 2, no. 1, pp. 1–8, 2019.
- [316] Y. Cao, Y. Zhao, Y. Wu, X. Yu, and J. Zhang, "Time-scheduled quantum key distribution (QKD) over WDM networks," *Journal of Lightwave Technology*, vol. 36, no. 16, pp. 3382–3395, 2018.
- [317] M. Mehic, P. Fazio, S. Rass, O. Maurhart, M. Peev, A. Poppe, J. Rozhon, M. Niemiec, and M. Voznak, "A novel approach to quality-of-service provisioning in trusted relay quantum key distribution networks," *IEEE/ACM Transactions on Networking*, vol. 28, no. 1, pp. 168–181, 2020.
- [318] Y. Zhao, K. Dong, T. Yang, Y. Li, and J. Zhang, "Tree-topology-based quantum-key-relay strategy for secure multicast services," *Journal of Optical Communications and Networking*, vol. 12, no. 5, pp. 120–132, 2020.
- [319] Y. Cao, Y. Zhao, J. Li, R. Lin, J. Zhang, and J. Chen, "Hybrid trusted/untrusted relay-based quantum key distribution over optical backbone networks," *IEEE Journal on Selected Areas in Communications*, vol. 39, no. 9, pp. 2701–2718, 2021.
- [320] Z. Li, G. Xu, X. Chen, X. Sun, and Y. Yang, "Multi-user quantum wireless communication based on multi-qubit GHZ state," *IEEE Communications Letters*, vol. 20, no. 12, pp. 2470–2473, 2016.
- [321] M. Alshowkan, B. P. Williams, P. G. Evans, N. S. Rao, E. M. Simmerman, H. H. Lu, N. B. Lingaraju, A. M. Weiner, C. E. Marvinney, Y. Y. Pai, B. J. Lawrie, N. A. Peters, and J. M. Lukens, "Reconfigurable quantum local area network over deployed fiber," *PRX Quantum*, vol. 2, p. 040304, Oct. 2021.
- [322] A. Aguado, V. Lopez, J. Martinez-Mateo, M. Peev, D. Lopez, and V. Martin, "Virtual network function deployment and service automation to provide end-to-end quantum encryption," *Journal of Optical Communications and Networking*, vol. 10, no. 4, pp. 421–430, 2018.
- [323] E. Hugues-Salas, F. Ntavou, D. Gkounis, G. T. Kanellos, R. Nejabati, and D. Simeonidou, "Monitoring and physical-layer attack mitigation in SDN-controlled quantum key distribution networks," *Optical Communications & Networking*, vol. 11, no. 2, pp. 209–218, 2019.
- [324] J. Li, Z. Zhou, N. Wang, Y. Tian, Y. Yang, and Y. Zheng, "Deterministic quantum secure direct communication protocol based on hyper-entangled state," *IEEE Access*, vol. 7, pp. 43 948–43 955, 2019.
- [325] Z. Zhang, X. Yuan, Z. Cao, and X. Ma., "Practical round-robin differential-phase-shift quantum key distribution," *New Journal of Physics*, vol. 19, no. 3, p. 033013, 2017.
- [326] Z. Rong, D. Qiu, and X. Zou, "Semi-quantum secure direct communication using entanglement," *International Journal of Theoretical Physics*, vol. 59, no. 6, pp. 1807–1819, 2020.
- [327] H. Pan, "Controlled bidirectional quantum secure direct communication with six-qubit entangled states," *International Journal of Theoretical Physics*, vol. 60, no. 8, pp. 2943–2950, 2021.
- [328] S. F. Ahmad, M. Y. Ferjani, and K. Kasliwal, "Enhancing security in the industrial IoT sector using quantum computing," in *Proc. 28th IEEE International Conference on Electronics, Circuits, and Systems (ICECS)*, 2021, pp. 1–5.
- [329] L. K. Grover, "Quantum mechanics helps in searching for a needle in a haystack," *Physical Review Letters*, vol. 79, no. 2, 1997.
- [330] L. K. Grover, "A fast quantum mechanical algorithm for database search," in *Proc. the 28th annual ACM symposium on Theory of computing*, 1996, pp. 212–219.
- [331] D. E. Knut, "The art of computer programming. 3 Sorting and searching," *Addison-Wesley, Reading, MA, USA.*, vol. 3, p. 736, 1973.
- [332] D. Chandra, P. Botsinis, D. Alanis, Z. Babar, S.-X. Ng, and L. Hanzo, "On the road to quantum communications," *Infocommunications Journal*, vol. 14, no. 3, pp. 2–8, 2022.
- [333] S. Mondal, M. R. Laskar, and A. K. Dutta, "ML criterion based signal detection of a MIMO-OFDM system using quantum and semi-quantum assisted modified DHA/BBHT search algorithm," *IEEE Transactions on Vehicular Technology*, vol. 70, no. 2, pp. 1688–1698, 2021.
- [334] C. Durr and P. Hoyer, "A quantum algorithm for finding the minimum," *arXiv preprint quant-ph/9607014*, 1996.
- [335] M. Boyer, G. Brassard, P. Høyer, and A. Tapp, "Tight bounds on quantum searching," *Fortschritte der Physik: Progress of Physics*, vol. 46, no. 4-5, pp. 493–505, 1998.
- [336] S. Endo, Y. Suzuki, K. Tsubouchi, R. Asaoka, K. Yamamoto, Y. Matsuzaki, and Y. Tokunaga, "Quantum error mitigation for rotation symmetric bosonic codes with symmetry expansion," *arXiv preprint arXiv:2211.06164*, 2022.
- [337] Y. Xiong, D. Chandra, S. X. Ng, and L. Hanzo, "Sampling overhead analysis of quantum error mitigation: Uncoded vs. coded systems," *IEEE Access*, vol. 8, pp. 228 967–228 991, 2020.
- [338] Y. Xiong, S. X. Ng, and L. Hanzo, "Quantum error mitigation relying on permutation filtering," *IEEE Transactions on Communications*, vol. 70, no. 3, pp. 1927–1942, 2022.
- [339] Y. Xiong, S. X. Ng, and L. Hanzo, "The accuracy vs. sampling overhead trade-off in quantum error mitigation using Monte Carlo-based channel inversion," *IEEE Transactions on Communications*, vol. 70, no. 3, pp. 1943–1956, 2022.
- [340] Z. Babar, D. Chandra, H. V. Nguyen, P. Botsinis, D. Alanis, S. X. Ng, and L. Hanzo, "Duality of quantum and classical error correction codes: Design principles and examples," *IEEE Communications Surveys & Tutorials*, vol. 21, no. 1, pp. 970–1010, 2019.

- [341] D. Chandra, Z. Babar, H. V. Nguyen, D. Alanis, P. Botsinis, S. X. Ng, and L. Hanzo, "Quantum coding bounds and a closed-form approximation of the minimum distance versus quantum coding rate," *IEEE Access*, vol. 5, pp. 11557–11581, 2017.
- [342] H. V. Nguyen, Z. Babar, D. Alanis, P. Botsinis, D. Chandra, M. A. Mohd Izhar, S. X. Ng, and L. Hanzo, "Towards the quantum Internet: Generalised quantum network coding for large-scale quantum communication networks," *IEEE Access*, vol. 5, pp. 17288–17308, 2017.
- [343] H. V. Nguyen, Z. Babar, D. Alanis, P. Botsinis, D. Chandra, S. X. Ng, and L. Hanzo, "EXIT-chart aided quantum code design improves the normalised throughput of realistic quantum devices," *IEEE Access*, vol. 4, pp. 10194–10209, 2016.
- [344] D. Chandra, Z. Babar, H. V. Nguyen, D. Alanis, P. Botsinis, S. X. Ng, and L. Hanzo, "Quantum topological error correction codes: The classical-to-quantum isomorphism perspective," *IEEE Access*, vol. 6, pp. 13729–13757, 2018.
- [345] T. C. Cuvelier, S. A. Lanham, B. R. L. Cour, and R. W. Heath, "Quantum codes in classical communication: A space-time block code from quantum error correction," *IEEE Open Journal of the Communications Society*, vol. 2, pp. 2383–2412, 2021.
- [346] D. Chandra, Z. Babar, S. X. Ng, and L. Hanzo, "Near-hashing-bound multiple-rate quantum turbo short-block codes," *IEEE Access*, vol. 7, pp. 52712–52730, 2019.
- [347] D. Chandra, Z. Babar, H. V. Nguyen, D. Alanis, P. Botsinis, S. X. Ng, and L. Hanzo, "Quantum topological error correction codes are capable of improving the performance of Clifford gates," *IEEE Access*, vol. 7, pp. 121501–121529, 2019.
- [348] M. A. Mohd Izhar, Z. Babar, H. V. Nguyen, P. Botsinis, D. Alanis, D. Chandra, S. X. Ng, and L. Hanzo, "Quantum turbo decoding for quantum channels exhibiting memory," *IEEE Access*, vol. 6, pp. 12369–12381, 2018.
- [349] F. Tacchino, S. Mangini, P. K. Barkoutsos, C. Macchiavello, D. Gerace, I. Tavernelli, and D. Bajoni, "Variational learning for quantum artificial neural networks," *IEEE Transactions on Quantum Engineering*, vol. 2, pp. 1–10, 2021.
- [350] S. Y.-C. Chen, C.-H. H. Yang, J. Qi, P.-Y. Chen, X. Ma, and H.-S. Goan, "Variational quantum circuits for deep reinforcement learning," *IEEE Access*, vol. 8, pp. 141007–141024, 2020.
- [351] V. Havlíček, A. D. Córcoles, K. Temme, A. W. Harrow, A. Kandala, J. M. Chow, and J. M. Gambetta, "Supervised learning with quantum-enhanced feature spaces," *Nature*, vol. 567, no. 7747, pp. 209–212, 2019.
- [352] N. Killoran, T. R. Bromley, J. M. Arrazola, M. Schuld, N. Quesada, and S. Lloyd, "Continuous-variable quantum neural networks," *Physical Review Research*, vol. 1, p. 033063, Oct. 2019.
- [353] I. Cong, S. Choi, and M. D. Lukin, "Quantum convolutional neural networks," *Nature Physics*, vol. 15, no. 12, pp. 1273–1278, 2019.
- [354] A. Mari, T. R. Bromley, J. Izaac, M. Schuld, and N. Killoran, "Transfer learning in hybrid classical-quantum neural networks," *Quantum*, vol. 4, p. 340, 2020.
- [355] H. Zhang, P. Liu, Y. Guo, L. Zhang, and D. Huang, "Blind modulation format identification using the DBSCAN algorithm for continuous-variable quantum key distribution," *Journal of the Optical Society of America B*, vol. 36, no. 3, pp. B51–B58, Mar. 2019.
- [356] K. Mitarai, M. Negoro, M. Kitagawa, and K. Fujii, "Quantum circuit learning," *Physical Review A*, vol. 98, p. 032309, Sep. 2018.
- [357] H. Chen, L. Wossnig, S. Severini, H. Neven, and M. Mohseni, "Universal discriminative quantum neural networks," *Quantum Machine Intelligence*, vol. 3, no. 1, pp. 1–11, 2021.
- [358] W. Huggins, P. Patil, B. Mitchell, K. B. Whaley, and E. M. Stoudenmire, "Towards quantum machine learning with tensor networks," *Quantum Science and Technology*, vol. 4, no. 2, p. 024001, 2019.
- [359] X. Gao, Z. Zhang, and L. Duan, "A quantum machine learning algorithm based on generative models," *Science Advances*, vol. 4, no. 12, p. eaat9004, 2018.
- [360] M. Xu, S. Wang, Q. Hu, H. Sheng, and X. Cheng, "Quantum analysis on task allocation and quality control for crowdsourcing with homogeneous workers," *IEEE Transactions on Network Science and Engineering*, vol. 7, no. 4, pp. 2830–2839, 2020.
- [361] D. Alanis, P. Botsinis, Z. Babar, H. V. Nguyen, D. Chandra, S. X. Ng, and L. Hanzo, "Quantum-aided multi-objective routing optimization using back-tracing-aided dynamic programming," *IEEE Transactions on Vehicular Technology*, vol. 67, no. 8, pp. 7856–7860, 2018.
- [362] J. Zhang, J. Lu, X. Yan, X. Xu, L. Qi, and W. Dou, "Quantified edge server placement with quantum encoding in Internet of vehicles," *IEEE Transactions on Intelligent Transportation Systems*, vol. 23, no. 7, pp. 9370–9379, Jul. 2022.
- [363] O. D. Matteo, V. Gheorghiu, and M. Mosca, "Fault-tolerant resource estimation of quantum random-access memories," *IEEE Transactions on Quantum Engineering*, vol. 1, pp. 1–13, 2020.
- [364] M. Kim, D. Venturelli, and K. Jamieson, "Leveraging quantum annealing for large MIMO processing in centralized radio access networks," in *Proc. the ACM Special Interest Group on Data Communication*, 2019, pp. 241–255.
- [365] S. Kasi, A. K. Singh, D. Venturelli, and K. Jamieson, "Quantum annealing for large MIMO downlink vector perturbation precoding," in *Proc. IEEE International Conference on Communications*, 2021, pp. 1–6.
- [366] A. A. A. El-Latif, B. Abd-El-Atty, W. Mazurczyk, C. Fung, and S. E. Venegas-Andraca, "Secure data encryption based on quantum walks for 5G Internet of Things scenario," *IEEE Transactions on Network and Service Management*, vol. 17, no. 1, pp. 118–131, 2020.
- [367] L. Feng, A. Ali, M. Iqbal, F. Ali, I. Raza, M. H. Siddiqi, M. Shafiq, and S. A. Hussain, "Dynamic wireless information and power transfer scheme for nano-empowered vehicular networks," *IEEE Transactions on Intelligent Transportation Systems*, vol. 22, no. 7, pp. 4088–4099, 2021.
- [368] J. Luo, Y. Shao, X. Liao, J. Liu, and J. Zhang, "Complex permittivity estimation for cloths based on QPSO method over (40 to 50) GHz," *IEEE Transactions on Antennas and Propagation*, vol. 69, no. 1, pp. 600–605, 2021.
- [369] J. Kim, Y. Kwak, S. Jung, and J.-H. Kim, "Quantum scheduling for millimeter-wave observation satellite constellation," in *Proc. IEEE VTS 17th Asia Pacific Wireless Communications Symposium (APWCS)*, 2021, pp. 1–5.
- [370] K. Kakaraparty, E. Muñoz-Coreas, and I. Mahhub, "The future of mm-wave wireless communication systems for unmanned aircraft vehicles in the era of artificial intelligence and quantum computing," in *Proc. IEEE MetroCon*, 2021, pp. 1–8.
- [371] W. Ye, W. Chen, X. Guo, C. Sun, and L. Hanzo, "Quantum search-aided multi-user detection for sparse code multiple access," *IEEE Access*, vol. 7, pp. 52804–52817, 2019.
- [372] C. Huang, J. Cao, S. Wang, and Y. Zhang, "Dynamic resource scheduling optimization with network coding for multi-user services in the Internet of vehicles," *IEEE Access*, vol. 8, pp. 126988–127003, 2020.
- [373] H. Zhang, C. Huang, J. Zhou, and L. Chen, "QoS-aware virtualization resource management mechanism in 5G backhaul heterogeneous networks," *IEEE Access*, vol. 8, pp. 19479–19489, 2020.
- [374] F. Li, W. Ji, S. Tan, Y. Xie, X. Guo, H. Liu, and Y. Yao, "Quantum bacterial foraging optimization: From theory to MIMO system designs," *IEEE Open Journal of the Communications Society*, vol. 1, pp. 1632–1646, 2020.
- [375] Y. Zhou, S. Tan, Y. Song, and F. Li, "Quantum bacterial foraging optimization based interference coordination in 3D-MIMO systems," in *Proc. IEEE Congress on Evolutionary Computation (CEC)*, 2019, pp. 627–633.
- [376] D. Xu and P. Ren, "Quantum learning based nonrandom superimposed coding for secure wireless access in 5G URLLC," *IEEE Transactions on Information Forensics and Security*, vol. 16, pp. 2429–2444, 2021.
- [377] T. Stollenwerk, S. Hadfield, and Z. Wang, "Toward quantum gate-model heuristics for real-world planning problems," *IEEE Transactions on Quantum Engineering*, vol. 1, pp. 1–16, 2020.
- [378] M. P. Harrigan, K. J. Sung, M. Neeley, K. J. Satzinger, F. Arute, K. Arya, J. Atalaya, J. C. Bardin, R. Barends, S. Boixo *et al.*, "Quantum approximate optimization of non-planar graph problems on a planar superconducting processor," *Nature Physics*, vol. 17, no. 3, pp. 332–336, Mar. 2021.
- [379] S. Hadfield, Z. Wang, B. O’gorman, E. G. Rieffel, D. Venturelli, and R. Biswas, "From the quantum approximate optimization algorithm to a quantum alternating operator ansatz," *Algorithms*, vol. 12, no. 2, p. 34, Feb. 2019.
- [380] Y. Zhao, Z. Fan, Z. Du, T. Zhi, L. Li, Q. Guo, S. Liu, Z. Xu, T. Chen, and Y. Chen, "Machine learning computers with fractal von Neumann architecture," *IEEE Transactions on Computers*, vol. 69, no. 7, pp. 998–1014, Jul. 2020.
- [381] J. Carolan, M. Mosheni, J. P. Olson, M. Prabhu, C. Chen, D. Bunandar, N. C. Harris, F. N. Wong, M. Hochberg, S. Lloyd, and D. Englund, "Variational quantum unsampling on a programmable nanophotonic processor," in *Proc. Conference on Lasers and Electro-Optics (CLEO)*, May 2019, pp. 1–2.
- [382] U. Mahadev, "Classical verification of quantum computations," in *Proc. IEEE 59th Annual Symposium on Foundations of Computer Science (FOCS)*, Oct. 2018, pp. 259–267.

- [383] N. Killoran, J. Izaac, N. Quesada, V. Bergholm, M. Amy, and C. Weedbrook, "Strawberry Fields: A software platform for photonic quantum computing," *Quantum*, vol. 3, p. 129, 2019.
- [384] V. Bergholm, J. Izaac, M. Schuld, C. Gogolin, S. Ahmed, V. Ajith, M. S. Alam, G. Alonso-Linaje, B. AkashNarayanan, A. Asadi *et al.*, "PennyLane: Automatic differentiation of hybrid quantum-classical computations," *arXiv preprint arXiv:1811.04968*, 2018.
- [385] A. Zulehner, A. Paler, and R. Wille, "An efficient methodology for mapping quantum circuits to the IBM QX architectures," *IEEE Transactions on Computer-Aided Design of Integrated Circuits and Systems*, vol. 38, no. 7, pp. 1226–1236, Jul. 2019.
- [386] Rigetti Computing. [Online]. Available: <https://www.rigetti.com>.
- [387] M. Avolio and A. Fuduli, "A semiproximal support vector machine approach for binary multiple instance learning," *IEEE Transactions on Neural Networks and Learning Systems*, vol. 32, no. 8, pp. 3566–3577, Aug. 2021.
- [388] Y. Yao, Y. Li, B. Jiang, and H. Chen, "Multiple kernel k -means clustering by selecting representative kernels," *IEEE Transactions on Neural Networks and Learning Systems*, vol. 32, no. 11, pp. 4983–4996, 2021.
- [389] D. P. Kingma and J. Ba, "Adam: A method for stochastic optimization," *arXiv preprint arXiv:1412.6980*, 2014.
- [390] T. Van Erven and P. Harremoës, "Rényi divergence and Kullback-Leibler divergence," *IEEE Transactions on Information Theory*, vol. 60, no. 7, pp. 3797–3820, 2014.
- [391] J. Bourassa and C. M. Wilson, "Progress toward an all-microwave quantum illumination radar," *IEEE Aerospace and Electronic Systems Magazine*, vol. 35, no. 11, pp. 58–69, 2020.
- [392] H. Dai, Q. Shen, C. Wang, S. Li, W. Liu, W. Cai, S. Liao, J. Ren, J. Yin, Y. Chen *et al.*, "Towards satellite-based quantum-secure time transfer," *Nature Physics*, vol. 16, no. 8, pp. 848–852, 2020.
- [393] M. W. Akhtar, S. A. Hassan, R. Ghaffar, H. Jung, S. Garg, and M. S. Hossain, "The shift to 6G communications: Vision and requirements," *Human-centric Computing and Information Sciences*, vol. 10, no. 53, pp. 1–27, 2020.
- [394] Quantum Computing Report. [Online]. Available: <https://quantumcomputingreport.com/privatestartup/>
- [395] Arqit. [Online]. Available: <https://arqit.uk.com>
- [396] "Cambridge Space Technologies," Apr. 2022. [Online]. Available: <https://www.cambridgespacetechnologies.com>
- [397] "Building trust in IoT security through legislation," Aug. 2021. [Online]. Available: <https://www.cryptoquantique.com/wp-content/uploads/2021/08/CQA009-Building-trust-in-IoT-security-through-legislation-v2.pdf>
- [398] CryptoNext Security. [Online]. Available: <https://cryptonext-security.com>
- [399] Entangled Networks. [Online]. Available: <https://www.entanglednetworks.com>
- [400] EYL. [Online]. Available: www.eylpartners.com/ckattempt=2
- [401] Isara. [Online]. Available: <https://www.isara.com/resource-center/managing-cryptographic-and-quantum-risk.html>
- [402] KETS Quantum. [Online]. Available: <https://kets-quantum.com>
- [403] Magiqtech. [Online]. Available: <https://www.magiqtech.com>
- [404] MU QUANTUM. [Online]. Available: <https://nu-quantum.com>
- [405] PQSolutions. [Online]. Available: <https://pqsolutions.us>
- [406] *Quantum Computing Threat: An Overview of Post-Quantum Cryptography*, PQShield, Oxford, OX2 7HT, UK, Aug 2022. [Online]. Available: <https://pqshield.com/whitepapers/an-overview-of-post-quantum-cryptography/>
- [407] Qabacus. [Online]. Available: <https://www.qabacus.com>
- [408] Qaisec. [Online]. Available: <http://www.qaisec.eu/>
- [409] QASKY. [Online]. Available: www.qasky.com
- [410] J. Yin, Y. Li, S. Liao, M. Yang, Y. Cao, L. Zhang, J. Ren, W. Cai, W. Liu, S. Li *et al.*, "Entanglement-based secure quantum cryptography over 1,120 kilometres," *Nature*, vol. 582, no. 7813, pp. 501–505, 2020.
- [411] Y. Chen, Q. Zhang, T. Chen, W. Cai, S. Liao, J. Zhang, K. Chen, J. Yin, J. Ren, Z. Chen *et al.*, "An integrated space-to-ground quantum communication network over 4,600 kilometres," *Nature*, vol. 589, no. 7841, pp. 214–219, Jan. 2021.
- [412] Y. Mao, B. Wang, C. Zhao, G. Wang, R. Wang, H. Wang, F. Zhou, J. Nie, Q. Chen, Y. Zhao *et al.*, "Integrating quantum key distribution with classical communications in backbone fiber network," *Optics Express*, vol. 26, no. 5, pp. 6010–6020, 2018.
- [413] Y. Cao, Y. Zhao, X. Yu, L. Cheng, Z. Li, G. Liu, and J. Zhang, "Experimental demonstration of end-to-end key on demand service provisioning over quantum key distribution networks with software defined networking," in *Proc. Optical Fiber Communication Conference*. Optical Society of America, 2019, pp. Th1G–4.
- [414] QEYnet. [Online]. Available: <https://www.qeynet.com>
- [415] QUDOOR. [Online]. Available: www.qudoor.cn
- [416] Quanticor. [Online]. Available: <https://quanticor-security.de/en/whitepaper-2/>
- [417] R. Kuang, "A deterministic polynomial public key algorithm over a prime Galois field $GF(p)$," in *Proc. 2nd Asia Conference on Computers and Communications (ACCC)*, Sep. 2021, pp. 79–88.
- [418] Quantum Bridge. [Online]. Available: <https://qubridge.io>
- [419] Quantumtrilogy. [Online]. Available: <https://quantumtrilogy.com>
- [420] Qubitkk. [Online]. Available: <https://qubitkk.com>
- [421] Quintessence labs. [Online]. Available: <https://www.quintessencelabs.com/wp-content/uploads/2020/12/QLabs-Advanced-Cybersecurity-Solutions-product-brochure.pdf>
- [422] QuSecure. [Online]. Available: <https://www.qusecure.com>
- [423] SpeQtral. [Online]. Available: <https://speqtral.space/>
- [424] VeriAloud. [Online]. Available: <https://veriquad.com>
- [425] A. Boaron, G. Boso, D. Rusca, C. Vulliez, C. Autebert, M. Caloz, M. Perrenoud, G. Gras, F. Bussi eres, M.-J. Li *et al.*, "Secure quantum key distribution over 421 km of optical fiber," *Physical Review Letters*, vol. 121, no. 19, p. 190502, 2018.
- [426] T. Weber, M. Riebisch, K. Borrass, K. Jansen, and D. Kr ucker, "Modelling for quantum error mitigation," in *Proc. IEEE 18th International Conference on Software Architecture Companion (ICSA-C)*, 2021, pp. 102–105.
- [427] M. Swathi and B. Rudra, "A novel approach for asymmetric quantum error correction with syndrome measurement," *IEEE Access*, vol. 10, pp. 44 669–44 676, 2022.
- [428] Swathi, Mummadi, Rudra, and Bhawana, "Novel encoding method for quantum error correction," in *Proc. IEEE 12th Annual Computing and Communication Workshop and Conference (CCWC)*, 2022, pp. 1001–1005.
- [429] H. Feng, Z. Cui, C. Han, J. Ning, and T. Yang, "Bidirectional green promotion of 6G and AI: Architecture, solutions, and platform," *IEEE Network*, vol. 35, no. 6, pp. 57–63, 2021.
- [430] M. R. Mahmood, M. A. Matin, P. Sarigiannidis, and S. K. Goudos, "A comprehensive review on artificial intelligence/machine learning algorithms for empowering the future IoT toward 6G era," *IEEE Access*, vol. 10, pp. 87 535–87 562, 2022.
- [431] S. Dvoretzky, N. Mikhailov, Y. Sidorov, V. Shvets, S. Danilov, B. Wittman, and S. Ganichev, "Growth of HgTe quantum wells for IR to THz detectors," *Journal of Electronic Materials*, vol. 39, no. 7, pp. 918–923, 2010.
- [432] K. Li, D. Suzuki, Y. Ochiai, and Y. Kawano, "Sensitivity enhancement of photothermoelectric Terahertz detectors with series combination between carbon nanotubes and metals," in *Proc. 43rd International Conference on Infrared, Millimeter, and Terahertz Waves (IRMMW-THZ)*, 2018, pp. 1–2.
- [433] A. Roy, J. Carriere, and R. Heyler, "THz-Raman characterization of graphene and two-dimensional nanomaterials," in *Proc. TechConnect World Innovation Conference & Expo*, 2016.
- [434] M. Zeng, A. Yadav, O. A. Dobre, G. I. Tsiropoulos, and H. V. Poor, "Capacity comparison between MIMO-NOMA and MIMO-OMA with multiple users in a cluster," *IEEE Journal on Selected Areas in Communications*, vol. 35, no. 10, pp. 2413–2424, 2017.
- [435] P. Gao, Z. Liu, P. Xiao, C. H. Foh, and J. Zhang, "Low-complexity block coordinate descend based multiuser detection for uplink grant-free NOMA," *IEEE Transactions on Vehicular Technology*, vol. 71, no. 9, pp. 9532–9543, 2022.
- [436] G. Cariolaro and G. Pierobon, "Performance of quantum data transmission systems in the presence of thermal noise," *IEEE Transactions on Communications*, vol. 58, no. 2, pp. 623–630, 2010.
- [437] Y. C. Eldar and G. D. Forney, "On quantum detection and the square-root measurement," *IEEE Transactions on Information Theory*, vol. 47, no. 3, pp. 858–872, 2002.
- [438] P. Botsinis, D. Alanis, Z. Babar, S. X. Ng, and L. Hanzo, "Iterative quantum-assisted multi-user detection for multi-carrier interleave division multiple access systems," *IEEE Transactions on Communications*, vol. 63, no. 10, pp. 3713–3727, 2015.
- [439] D. Mogilevtsev, I. Peshko, I. Karuseichyk, A. Mikhalychev, A. P. Nizovtsev, G. Y. Slepyan, and A. Boag, "Quantum noise radar: Assessing quantum correlations," in *Proc. IEEE International Conference on Microwaves, Antennas, Communications and Electronic Systems (COMCAS)*, 2019, pp. 1–3.

- [440] S. Mikki, "Quantum antenna theory for secure wireless communications," in *Proc. 14th European Conference on Antennas and Propagation (EuCAP)*, 2020, pp. 1–4.
- [441] Z. Xie, Y. Lefier, M. A. Suarez, M. Mivelle, R. Salut, J. M. Merolla, and T. Grosjean, "Doubly resonant photonic antenna for single infrared quantum dot imaging at telecommunication wavelengths," *Nano Letters*, vol. 17, no. 4, pp. 2152–2158, 2017.
- [442] G. Gil, G. Goldoni, and S. Corni, "Enhanced light-harvesting of protein-pigment complexes assisted by a quantum dot antenna," in *Proc. Nanotechnology for Instrumentation and Measurement (NANOIM)*, 2018, pp. 1–5.
- [443] Y. Lin, D. R. Leibrandt, D. Leibfried, and C. Chou, "Quantum entanglement between an atom and a molecule," *Nature*, vol. 581, no. 7808, pp. 273–277, 2020.
- [444] X. Hu, C. Huang, Y. Sheng, L. Zhou, B. Liu, Y. Guo, C. Zhang, W. Xing, Y. Huang, C. Li *et al.*, "Long-distance entanglement purification for quantum communication," *Physical Review Letters*, vol. 126, no. 1, p. 010503, 2021.
- [445] A. Conrad, S. Isaac, R. Cochran, D. Sanchez-Rosales, B. Wilens, A. Gutha, T. Rezaei, D. J. Gauthier, and P. Kwiat, "Drone-based quantum key distribution (QKD)," in *Proc. Free-space laser communications XXXIII*, vol. 11678, 2021, pp. 177–184.
- [446] M. T. Gruneisen, M. Dusek, J. G. Rarity, M. Mariola, and F. Petruccione, "Free-space optical communication alignment system," in *Proc. Quantum Information Science and Technology II*, vol. 9996, 2016, pp. 113–120.
- [447] Y. Kaymak, R. Rojas Cessa, J. Feng, N. Ansari, M. Zhou, and T. Zhang, "A survey on acquisition, tracking, and pointing mechanisms for mobile free-space optical communications," *IEEE Communications Surveys & Tutorials*, vol. 20, no. 2, pp. 1104–1123, 2018.
- [448] T. Jono, M. Toyoda, K. Nakagawa, A. Yamamoto, K. Shiratama, T. Kurii, and Y. Koyama, "Acquisition, tracking, and pointing systems of OICETS for free space laser communications," in *Proc. Acquisition, tracking, and pointing XIII*, vol. 3692, 1999, pp. 41–50.
- [449] L. Mucchi, S. Jayousi, S. Caputo, E. Paoletti, P. Zoppi, S. Geli, and P. Dioniso, "How 6G technology can change the future wireless healthcare," in *Proc. 2nd 6G Wireless Summit (6G SUMMIT)*, 2020, pp. 1–6.
- [450] F. Liu, Y. Cui, C. Masouros, J. Xu, T. X. Han, Y. C. Eldar, and S. Buzzi, "Integrated sensing and communications: Toward dual-functional wireless networks for 6G and beyond," *IEEE Journal on Selected Areas in Communications*, vol. 40, no. 6, pp. 1728–1767, 2022.
- [451] N. Panunzio, C. Occhiuzzi, and G. Marrocco, "Propagation modeling inside the international space station for radio frequency identification and sensing of astronauts," in *Proc. 23rd General Assembly and Scientific Symposium of the International Union of Radio Science*, 2020, pp. 1–4.
- [452] J. Ma, Y. Zhou, X. Yuan, and X. Ma, "Operational interpretation of coherence in quantum key distribution," *Physical Review A*, vol. 99, no. 6, Jun. 2019.
- [453] K. Wu, Z. Hou, H. Zhong, Y. Yuan, G. Xiang, C. Li, and G. Guo, "Experimentally obtaining maximal coherence via assisted distillation process," *Optica*, vol. 4, no. 4, pp. 454–459, Apr. 2017.
- [454] N. Abbas, Y. Zhang, A. Taherkordi, and T. Skeie, "Mobile edge computing: A survey," *IEEE Internet of Things Journal*, vol. 5, no. 1, pp. 450–465, 2018.