

# Demand-Side Threats to Power Grid Operations from IoT-Enabled Edge

Subhash Lakshminarayana, Carsten Maple, Andrew Larkins, Daryl Flack, Christopher Few, and Anurag. K. Srivastava

**Abstract**—The growing adoption of Internet-of-Things (IoT)-enabled energy smart appliances (ESAs) at the consumer end, such as smart heat pumps, electric vehicle chargers, etc., is seen as key to enabling demand-side response (DSR) services. However, these smart appliances are often poorly engineered from a security point of view and present a new threat to power grid operations. They may become convenient entry points for malicious parties to gain access to the system and disrupt important grid operations by abruptly changing the demand. Unlike utility-side and SCADA assets, ESAs are not monitored continuously due to their large numbers and the lack of extensive monitoring infrastructure at consumer sites. This article presents an in-depth analysis of the demand side threats to power grid operations including (i) an overview of the vulnerabilities in ESAs and the wider risk from the DSR ecosystem and (ii) key factors influencing the attack impact on power grid operations. Finally, it presents measures to improve the cyber-physical resilience of power grids, putting them in the context of ongoing efforts from the industry and regulatory bodies worldwide.

## I. INTRODUCTION

Demand side response (DSR) is seen as a critical element in achieving the net-zero goals set by several nations worldwide. It refers to the ability to shift load away from the peak demand periods and potentially align them with renewable energy generation. Energy smart appliances (ESAs), such as smart heat pumps, electric vehicle charging stations, etc., can offer DSR. The connectivity features of these smart devices can be leveraged to control them remotely. This can enable scheduling their usage during off-peak periods or provide on-demand services (e.g., increase/decrease demand by direct load control) while respecting the consumer’s usage preferences and giving them “override” privileges whenever needed. The penetration of ESAs is expected to grow significantly in the future. In the UK, it is projected that 6.9-11.3 million domestic heat pumps will be installed by 2035 and an uptake of 10 million EVs by 2030.

Fig. 1 shows logical DSR architecture and the entities involved in DSR. Intermediary organisations called “Demand-side response service providers” (DSRSPs) are responsible for providing DSR by directly (e.g., direct load control) or indirectly (e.g., through pricing schemes) controlling ESAs.

S. Lakshminarayana (Corresponding author) and C. Maple are with the University of Warwick, Coventry, CV47AL, UK. (Emails: subhash.lakshminarayana@warwick.ac.uk, cm@warwick.ac.uk). A. Larkins is with Sygensys Ltd, Didcot OX11 0QX. (Email: al@sygensys.com). D. Flack is with BLOCKPHISH, London, W1T 6EB, UK. (Email: Daryl.Flack@BLOCKPHISH.com). C. Few is with National Grid, UK. (Email: christopher.few@nationalgrid.com). A. K. Srivastava is with West Virginia University, USA. (Email: anurag.srivastava@mail.wvu.edu). This work was supported by the PETRAS National Centre of Excellence for IoT Systems Cybersecurity through the U.K. EPSRC under Grant EP/S035362/1.

Customer energy management (CEM) are logical entities used to manage ESAs in order to provide DSR. The entities involved in the DSR ecosystem are connected via communication interfaces (i.e., Interface A and B in Fig. 1).

### A. Cyber Threats from Energy Smart Appliances Against Power Grids

While the benefits of ESAs are undeniable, they also pose cyber security risks. Several security vulnerabilities have been discovered in ESAs and the associated DSR communication interfaces (see Section II for more details). These vulnerabilities can pose a serious threat to consumer’s privacy and security. More importantly, as the ESA penetration levels increase, they may become a new attack surface to target power grids.

The balance between the supply (i.e., generation) and the demand (i.e., loads) is critical for power grid operations. A sudden surge or drop in the demand can lead to severe disruption of power grid operations. This can happen due to (i) cyber attack that compromises ESAs or the ESA-DSRSP communication interfaces and changes the load control settings of a large number of ESAs in a coordinated manner leading to several mega-watts of load change within a short interval [1], [2], (ii) consumers acting in a coordinated but unexpected way, e.g., in response to an external prompt, and or (iii) ESAs responding at scale in a coordinated but unexpected way, e.g., due to misconfiguration, coding errors or an external signal. A pictorial depiction of such attacks is presented in Figure 2.

Real-world instances of cyber-attacks that led to compromising ESAs have already been witnessed [3]. Large-scale changes in demand (amounting to several mega-watts) have also been witnessed due to synchronised actions from a large number of customers (though they did involve cyber-attacks). The notable incidents include the following:

- The “TV pick-up” effect is experienced by the GB grid, which refers to a rapid surge or drop in electricity demand during popular football events. For instance, during England’s victory over Germany in UEFA EURO 2020, National Grid witnessed a “1 GW pick-up in electricity demand at half-time in the match, and around a 1.6 GW pick-up after full-time (equivalent power to around 320 million light bulbs and 888,000 kettles)”.
- The “Pan-India Lights Switch Off Event” on 5 April 2020, in which the Indian government urged citizens to switch off electric lights and light lamps to show their support in the fight against the COVID pandemic, resulted in a nationwide demand drop of 31 GW.
- The heatwave in California in September 2022 severely stressed the power grid. Subsequent SMS messages sent

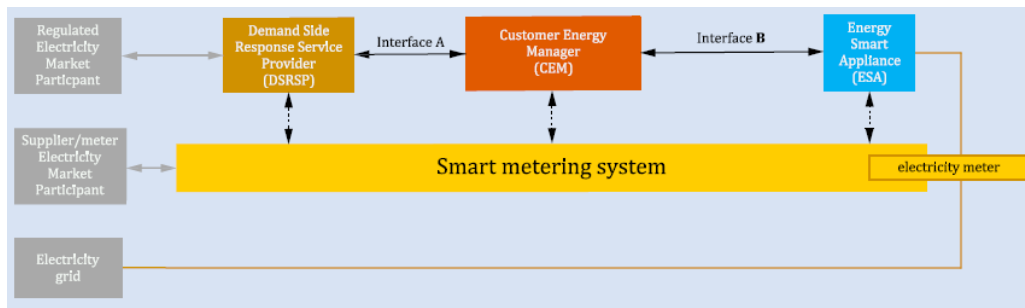

Fig. 1: Logical DSR architecture and communications connections. (Figure source: British Standards Institution)

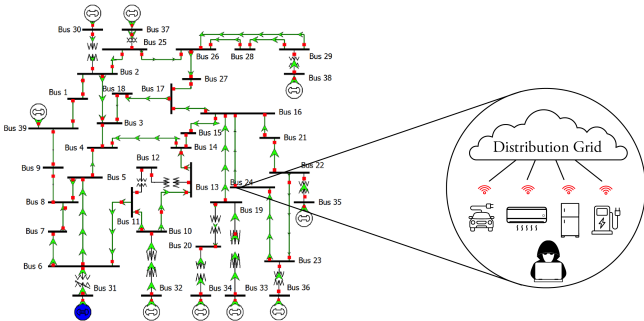

Fig. 2: Load-altering attacks against power grids

by the governor’s office to 27 million residents urging them to turn off non-essential power resulted in a drop of 2GW demand.

Fortunately, power grid operators were able to anticipate the load changes during all the events mentioned above, and suitable generation resources (such as pumped storage hydroelectric power stations) were dispatched to compensate for the power imbalance. However, in case of a cyber event resulting in large-scale load changes, such surges/drops in demand may be completely unanticipated, potentially causing significant disruption. Considering these concerns, several nations are in the process of formulating regulations aimed at minimising cyber risks from ESAs. The most notable ones include the following:

- UK’s Department of Energy Security and Net Zero (DESNZ) recently launched a “Consultation on interoperability and cyber security of energy smart appliances and remote load control”. The consultation includes important proposals to improve the cyber security of the ESA ecosystem, such as requiring ESAs to comply with minimum cyber security standards using the ETSI 303 645 framework and bringing load-controlling organisations under National Information and Systems (NIS) regulations.
- The European Union approved an “action plan for the digitalisation of the energy system”, which includes establishing requirements to facilitate data access for demand response, as well as to support the adoption of ESAs.
- The United States has introduced “Cybersecurity Labeling Program for Smart Devices” with the objective of helping consumers to choose ESAs that are safer and less vulnerable to cyberattacks.

This paper presents an in-depth analysis and insights into demand-side attacks against power grids, including risk and attack impact analysis on power grid operations. It also highlights measures to enhance cyber-physical resilience against such attacks by recommending attack detection and mitigation measures. Finally, it provides key conclusions and recommendations to power grid operators and policymakers in this area.

## II. THREAT AND RISK ANALYSIS

The profound digitisation of power grids and their symbiotic integration with Internet of Things (IoT) technologies presents a complex operational landscape replete with various threats. To effectively navigate this realm, a nuanced understanding of these threats and their inherent risks is essential.

The authors have delved into the extensive IoT honeypot datasets provided by Global Cyber Alliance (GCA), distilling insights from 7 terabytes of data accrued over a span of two years from a diverse cohort of devices [4]. Our focal point spanned the gamut of attacker profiles—including geo-locations, IP addresses, and ports utilised for IoT device incursions. The attack vectors, encompassing the URLs used for downloading the attack mechanisms, the threats implemented, and the commands executed, were also brought under our analytical lens. We summarise the findings in the following.

### A. Key Vulnerabilities in ESAs

First, we enlist the cyber vulnerabilities in ESAs and how they can be exploited to impact power grid operations.

- **Weak Authentication Mechanisms:** A considerable number of IoT devices, such as smart routers and smart home appliances, are hampered by suboptimal authentication frameworks. Weak authentication in ESAs can allow privilege escalation attacks, enabling direct control by unauthorised entities. In smart routers, it could allow load control commands to be diverted, and therefore ESAs not receiving the right commands or receiving spoofed ones. Such attacks can have the capacity to modify the load-controlling settings of IoT devices, thereby causing pronounced load fluctuations.
- **Lack of Security Updates:** Many IoT devices are not privy to regular software enhancements, exposing them to augmented risk from cyber incursions. This is a particular concern for ESAs, which, unlike many other consumer IoT devices, are expected to have a 10-year plus lifetime.

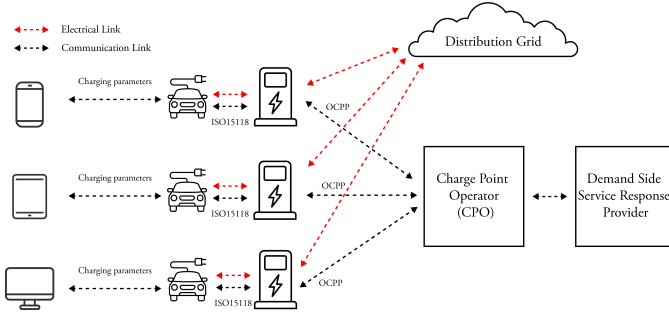

Fig. 3: Electric vehicle charging system. ISO-15118 and OCPP refer to the communication protocols used in EV-EVCS and EVCS-central server communication.

- **Remote Code Execution (RCE):** Alarming, many IoT devices lack stringent access control measures. RCE attacks pose a significant threat, allowing malicious entities to execute arbitrary code on remote machines, potentially leading to further malware deployment or data exfiltration.
- **Restriction Bypass:** This vulnerability can be exploited by adversaries to manipulate or exploit applications. Common avenues for such incursions include the use of hardcoded user accounts and credentials. The vulnerability can be exploited to control load control functions within devices at scale to cause grid instability.
- **Insecure Web Interface:** Devices with inadequately secured web interfaces are vulnerable to unauthorised access, presenting a significant risk. This can lead to remote load control capability at scale potentially leading to grid instability.

While the vulnerabilities listed above are focused specifically on the ESAs, there is a wider risk of access to the load-controlling systems from the communication interfaces involved in DSR operations. Take the example of a smart electric vehicle charging station (EVCS) shown in Fig. 3. They can be targeted in several ways (other than compromising the EVCS themselves), such as

- Compromising the communication interfaces between ESAs, CEMs, and the DSRSP. E.g., the OCPP protocol used for communication between the EVCS to the CS is known to be vulnerable to man-in-the-middle (MitM) attacks [5].
- Compromising smart-phone applications used by consumers to control the charging operation.
- Social-engineering attacks targeting consumers leading to synchronised customer behaviour.

### B. Attack Vectors

The honeypot data analysis also sheds light on potential attack vector, which we enlist in the following.

- **Load-Altering Attacks (LAAs):** A pivotal threat in the domain of IoT, LAAs have the capacity to modify the load-controlling settings of IoT devices, thereby causing pronounced load fluctuations. Such alterations could have a direct bearing on power grid dynamics. For instance, vulnerabilities that allow escalation of user privileges can enable adversaries to remotely control devices, potentially inducing significant instability in the power grid.

- **Denial of Services (DoS & DDoS):** These attacks are meticulously designed to overwhelm target systems. DDoS attacks, in particular, are more dispersed and pose a greater challenge due to their origin from multiple sources. Such attacks can cause disruption to the systems or devices used in load control leading to loss of DSR services which could impact grid operations.

In summation, the potential implications of these vulnerabilities extend beyond mere theoretical constructs. The following segment, discussing the impact of LAAs on power grids, vividly portrays the tangible repercussions of these threats on power grid dynamics. The intricate weave between power grids and IoT devices underscores the imperative for a comprehensive and holistic approach to threat and risk analysis, characterised by persistent vigilance, in-depth scrutiny, and proactive defence mechanisms.

### III. ATTACK IMPACT ANALYSIS

The power grid frequency is an indicator of the balance between the supply (generation) and the demand. Grid operators must ensure the balance at all times and maintain the frequency at a pre-defined set point, e.g., 50 Hz in the UK. Sudden and abrupt manipulation of the power grid demand due to large-scale cyber attacks against ESAs can disrupt this balance and lead to severe effects, such as unsafe frequency excursions, eventually leading to cascading line and generator outages. The August 9, 2019, event involving the UK power grid provides a real-world example of the consequences [6]. On this day, a lightning strike followed by the loss of embedded generation caused a major power imbalance between supply and demand, causing power outages to 1.1 million customers (including a hospital) and significant railway disruptions. In the following, we list some key factors influencing the attack impact.

- **Magnitude of Vulnerable Load:** For LAAs to be impactful, an adversary must be able to alter a significant amount of load since power grid design philosophies, such as N-1 contingency scheduling provide resilience against component loss, such as the loss of a generator or a transmission line as well as large-scale load changes. Our studies suggest that LAA magnitudes in the range of hundreds of megawatts can severely impact the power grid's safety, potentially leading to cascading failures [7]. As grid operators make increased use of DSR to help balance supply and demand on the grid, LAAs of such a large magnitude are in the realm of possibility in the near future. For instance, in the UK, a 300 MW threshold is expected to be applied for load controllers to be considered Operators of Essential Services under the Network and Information Systems Regulations and the licencing framework for this is expected to be introduced during 2025 [8].
- **Duration Over which the Load Changes Occurs:** The smaller the duration over which the load change occurs, the greater the attack impact. For instance, if the entire load change under the LAA is concentrated over a sub-second interval, the grid operator can only rely on the system's

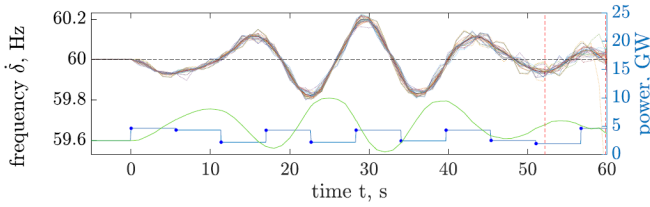

Fig. 4: Example of a one-time step attack (top figure) and oscillatory attack (bottom figure). Network frequency profiles (black), network generation profiles (green), and network load profiles (blue). Load changes are depicted with a blue marker and emergency responses as vertical red dashed lines at the time of their occurrence. (Figure source [7])

inertial response to mitigate the power imbalance. On the other hand, if the load change occurs over a relatively longer duration (tens of seconds to a minute), fast-acting local frequency responses such as battery energy storage systems can be leveraged to correct the imbalance (see Section 6). For slower load changes (those that take more than several minutes), the operator can redispatch the generators to compensate for the load changes (i.e., bring new generation sources online).

- **Spatial Factors:** Another key finding is that the impact of a load-altering attack depends critically on the geographical location of the ESAs that are targeted under a cyber-attack [9]. In other words, an identical magnitude of load change at different locations will impact power grid operations differently. Furthermore, a coordinated attack from multiple locations in the grid can severely threaten the grid's safety.
- **Temporal factors:** The risk factor due to load-altering attacks varies as a function of the diurnal, weekly or seasonal load conditions. For instance, during the peak demand periods (e.g., evening period), the power grid is operating close to its capacity limits, and even a relatively small increase in loads can overwhelm the system and trigger emergency actions such as load shedding (subsequently leading to blackouts). Moreover, strategic attackers can also coordinate their attacks during extreme weather events (such as storms or flood disruptions), during the time when the power grid is already under extreme stress.
- **Sophisticated Attack Patterns:** While a one-time surge or drop in the demand is undesirable, sophisticated attack patterns such as oscillatory load variations (periodic increase and decrease in demand) can seriously threaten the power grid stability (see Fig. 4). Studies have found that such strategic load variations can induce power grid failures by manipulating a lower fraction of the demand as compared to one-time load changes.
- **Renewable Energy Penetration Conditions:** The growing integration of renewable energy resources (RESs) will further exacerbate the vulnerability of power grids to LAAs. Unlike conventional generators (such as those based on fossil fuels) that have large inertia<sup>1</sup>, RESs (such

<sup>1</sup>The generator's inertia, which refers to the kinetic energy stored in the spinning parts of the generators plays a critical role in slowing down the rate-of-change-of-frequency following a disturbance.

as solar and wind energy) do not have the same inherent capability of providing inertia to the power system. Thus, when faced with an IoT-enabled load-altering attack, the grid with a high penetration of RESes will witness a large frequency swing.

#### IV. ENHANCING CYBER-PHYSICAL SYSTEM RESILIENCE

Given the growing penetration of ESAs in the foreseeable future and the lack of a current unified approach to implementing security standards, there is no silver bullet to eliminating demand-side cyber threats. Although regulators, device manufacturers, and operators are in the process of identifying potential LAA threats and introducing appropriate regulations, there will remain a risk of a successful attack. Thus, operators must prepare strategies to counter the adverse effects of such attacks. This can be done in three stages.

- **Protect:** Implement device-level or grid-level protection features to prevent or restrict the LAA risk /impact from occurring.
- **Detect:** If a successful LAA is executed, develop a monitoring framework to detect and localise the compromised regions of the power grid quickly.
- **Respond and Recover:** Develop attack mitigation and isolation techniques.

##### A. Protecting Against Load-Altering Attacks

First, we enlist some approaches that can be designed to protect the system that can prevent the risk and the impact of LAAs.

- Setting randomised offset to device start times or limits to ramping demand within devices would provide the grid more time to accommodate increases and decreases in load.
- Frequency response functionality in the design of load devices could help manage fluctuations with devices modulating their own load if they detect frequency changes. The downside of this approach is that it would mean less control to grid operators, who like to have more of a manual hand on the frequency adjustments.
- An anomaly detection service could be used to correlate the original flexibility requests sent from the transmission grid operator (e.g., National Grid) to the DSRSP, with the requests that the DSRSPs sends to the end devices. This would enable the detection and (where appropriate) blocking of anomalous load control messages from DSRSPs to devices by ensuring that the amount of load control requests sent, correlates broadly with the original instruction. This approach would however, require a central service to correlate and orchestrate all load control commands which may introduce latency and response times.

##### B. Detecting Load-Altering Attacks

LAAs can be detected and localized by deploying a cyber-physical monitoring framework either at the bulk power or distribution grid levels.

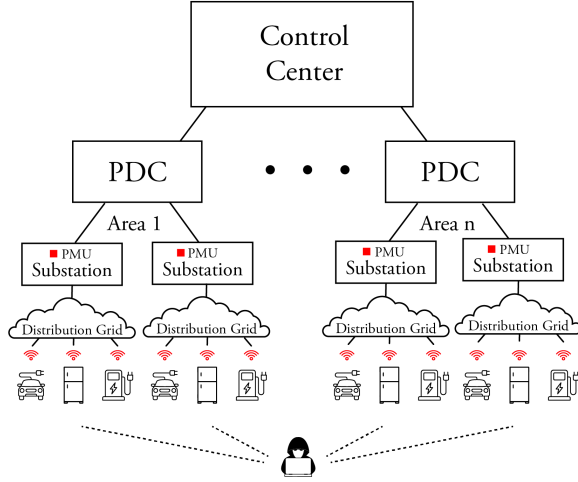

Fig. 5: Monitoring framework at bulk power grid level. PMU - Phasor measurement unit, PDC - Phasor data concentrator.

1) *Monitoring Framework at Bulk Power Grid Level:* At the bulk power grid level, measuring the end-user demand in real-time is not practical. Nevertheless, LAAs can be localized by monitoring the power grid dynamics (i.e., voltage phase angle and frequency fluctuations) and inferring the attack parameters/attack location using machine learning algorithms. Advanced analytic techniques such as multi-dimensional convolutional neural networks can capture the correlations between power grid signals measured at different locations and quickly detect and localize LAA [10]. Such a detection mechanism can be seamlessly integrated into existing wide-area monitoring systems, as shown in Figure 5. However, for practical implementation, the monitoring framework would require upgrades to the existing power grid supervisory and data acquisition (SCADA) systems, since the grid dynamics must be monitored at a fast time scale (typical existing SCADA systems have a refresh rate of 5 -10 seconds, which is not sufficient for quick detection of LAAs). Advanced sensing devices such as phasor measurement units (PMUs) can provide a sub-second measurement update rate, but their deployment in real power systems is limited. The proposed solution also needs a monitoring infrastructure that can collect and process the PMU data, and other high temporal resolution data, in real time.

Furthermore, analysis of SCADA and PMU data can contribute to approximately geolocating the source of an LAA, but it does not help identify the specific ESAs involved in the attack. For example, a LAA may affect 50,000 heat pumps from a specific manufacturer or a set of ESA controlled by one aggregator. Further research is required to identify the data sets, tools and techniques that could be used for post-LAA investigation and root cause analysis. A potential approach could be requiring devices to send their security logs to a central “Security Operations Centre” and correlate that with the bulk grid monitoring. However, this will likely need some consumer consent and privacy notice when signing up for DSRSP services.

2) *Monitoring Framework at the Distribution Grid Level:* A monitoring framework deployed at the distribution grid level

can provide a more fine-grained localisation of LAAs, e.g., identify the compromised ESAs or the distribution network feeders. However, the challenge is that distribution networks are monitored poorly, unlike transmission networks. Moreover, power utilities do not have direct access to all the IoT’s data. Data integrity and customer privacy are significant concerns when it comes to the use of IoT data.

Federated learning can help tackle the data scarcity issue and protect user data privacy by not bringing the raw user data out of the privacy-protected area. In this context, both cyber and physical features from IoT devices can be leveraged, such as source/destination IP, source/destination port, packet length, protocols, intra-packet arrival time, load, temperature setpoint, indoor area, building thermal insulation, power generation, rating, solar irradiance, charging/discharging rate, battery state of charge (SoC), etc. The autoencoder is adept at capturing intricate correlations and interactions among these diverse features by compressing data into a lower-dimensional representation. The autoencoder neural network model can be adapted for use within the federated learning framework. By applying federated learning and incorporating these diverse features, the distribution network operator can calculate an overall IoT trustability score (ITS) while concurrently safeguarding the privacy of IoTs [11].

### C. Respond and Recover

Responding to the attack, i.e., attack mitigation, in turn, involves two phases. In the short term (sub-second to minutes), actions must be taken to prevent the system from destabilising and moving toward cascading failures. At a longer timescale (tens of minutes to hours), the attack must be isolated, and the system must be restored to a safe operational state.

In the short term, power from fast-acting resources (such as battery energy storage systems) can be an effective source to mitigate the imbalance caused by LAAs. Modern-day power grids are already facing significant power imbalances (with or without cyber attacks), for example, instantaneous changes in power balance due to tripping of generation or interconnectors, and minute-by-minute imbalances due to the increasing penetration of renewables. The power grid operators are already introducing several measures to deal with these challenges. (i) The UK’s National Grid is in the process of introducing faster-acting frequency response products, namely, dynamic regulation, dynamic balancing, and dynamic containment. Fig. 6 shows the response characteristics of these services, i.e., power requirements as a function of the grid frequency variation. The aim of these services is to quickly mitigate imbalances and keep the grid frequency around the setpoint of 50Hz. (ii) Use of zero-carbon synchronous compensators to deliver inertia to the grid. (iii) Use of offshore wind and vehicle-to-grid functionality to provide short-term grid balancing and grid stability services.

While these measures can also be applied to stabilise the imbalance created due to load-altering attacks, mitigating cyber attacks will be significantly more challenging. This is because, in the case of cyber attacks, the mitigation responses are tightly coupled with attack detection (e.g., using

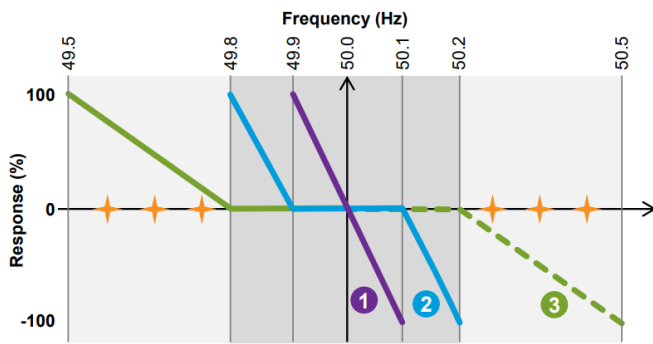

Fig. 6: National Grid's new frequency response services, 1. Dynamic regulation, 2. Dynamic balancing, and 3. Dynamic containment (Source: National Grid ESO)

the monitoring framework described above), which involves significant uncertainties in their detection/localisation results (such as false positives and misdetections) as well as detection delays. Furthermore, the interactions between the cyber and the physical layer need to be considered during the restoration process. Overall, innovative control technologies must be designed to deal with these uncertainties and keep the system stable.

Finally, the long-term attack isolation problem is a challenge that has still not received sufficient attention and much research will be needed in this direction. Looking forward, identifying large loads and having a secure backup communication channel for manual override of ESAs in the event of imminent outages (even if it's devolved to more local areas), may be an option. However, consumer impacts would need to be carefully considered as well as the risk that control itself introduces.

## V. KEY CONCLUSIONS AND RECOMMENDATIONS

We conclude the manuscript by highlighting the key conclusions and recommendations to power grid operators and policy making organisations in this sector.

- The magnitude of the compromised load, as well as spatial and temporal factors of LAAs are important aspects that determine the attack impact. Efforts to regulate load-controlling organizations (e.g., bring them under cyber security regulations) must take these factors into account. Grid operators must perform feasibility studies to determine the "weak points" in the grid from which large-scale load variations have the most impact.
- Sophisticated attacks such as oscillatory load variations can have a more grave impact as compared to a step change in the load, with the potential to induce power grid failures by manipulating a lower fraction of loads.
- Ongoing efforts to decarbonize the power grid by integrating renewable energy resources on a large scale can result in extremely low inertia conditions, further exacerbating the vulnerability of grids to LAAs. The silver lining though is that if these resources are used intelligently (e.g., fast-frequency response, provision of synthetic inertia), they may increase the system's uptime when faced with LAAs (see the final conclusion).
- Power grid physical signals can be an important source of information to detect and localize the attacks (in addition

to the cyber information). However, more research is needed to address the associated practical issues.

- Given that fully preventing cyber attacks can be extremely challenging, operators must prepare reactive strategies to counter the effects of LAAs. Energy storage and fast-acting inverter-based resources can be effective sources to mitigate the destabilizing effects of LAAs and increase the system's uptime. Innovative control techniques need to be developed to adapt existing frequency stabilisation methods to mitigate cyber attacks.

## REFERENCES

- [1] A. Dabrowski, J. Ullrich, and E. R. Weippl, "Grid shock: Coordinated load-changing attacks on power grids: The non-smart power grid is vulnerable to cyber attacks as well," in *Proc. Annual Computer Security Applications Conference*, 2017.
- [2] S. Soltan, P. Mittal, and H. V. Poor, "BlackIoT: IoT botnet of high wattage devices can disrupt the power grid," in *Proc. USENIX Security Symposium*, Aug. 2018, pp. 15–32.
- [3] "Electric car charging points hacked to show porn in isle of wight," <https://news.sky.com/story/isle-of-wight-councils-electric-car-charging-points-hacked-to-show-porn-12584211> - Accessed 15, Oct. 2023.
- [4] "Global cyber alliance launches cybersecurity development platform for internet of things (IoT) devices," <https://www.globalcyberalliance.org/global-cyber-alliance-launches-cybersecurity-development-platform-for-internet-of-things-iot-devices/> - Accessed 15, Oct. 2023.
- [5] C. Alcaraz, J. Lopez, and S. Wolthusen, "OCPP protocol: Security threats and challenges," *IEEE Transactions on Smart Grid*, vol. 8, no. 5, pp. 2452–2459, 2017.
- [6] "Technical report of the events of 9 august, 2019," <https://www.nationalgrideso.com/document/152346/download> - Accessed 15, Oct. 2023.
- [7] M. P. Goodridge, S. Lakshminarayana, and A. Zocca, "Uncovering load-altering attacks against N-1 secure power grids: A rare-event sampling approach." [Online]. Available: <https://arxiv.org/abs/2307.08788v1>
- [8] "Delivering a smart and secure electricity system: the interoperability and cyber security of energy smart appliances and remote load control," <https://www.gov.uk/government/consultations/delivering-a-smart-and-secure-electricity-system-the-interoperability-and-cyber-security-of-energy-smart-appliances-and-remote-load-control> - Accessed 15, Oct. 2023.
- [9] S. Lakshminarayana, S. Adhikari, and C. Maple, "Analysis of IoT-based load altering attacks against power grids using the theory of second-order dynamical systems," *IEEE Trans Smart Grid*, vol. 12, no. 5, pp. 4415–4425, 2021.
- [10] H. Jahangir, S. Lakshminarayana, C. Maple, and G. Epiphaniou, "A deep-learning-based solution for securing the power grid against load altering threats by IoT-enabled devices," *IEEE Internet of Things Journal*, vol. 10, no. 12, pp. 10 687–10 697, 2023.
- [11] P. S. Sarker, S. K. Sadanandan, and A. K. Srivastava, "Resiliency metrics for monitoring and analysis of cyber-power distribution system with IoTs," *IEEE Internet of Things Journal*, vol. 10, no. 9, pp. 7469–7479, 2023.

**Subhash Lakshminarayana** is an associate professor at the University of Warwick, UK. His research interests include cyber-physical system security, power grid optimization/control and wireless communications. He serves as Associate Editor at the IEEE Internet of Things and IET smart grid journal. His works have been selected among the Top 5 papers published in IEEE Transactions on Smart Grid 2021, the Best conference paper candidates at the IEEE PESGM - 2015 and IEEE Globecom 2014 conferences.

**Carsten Maple** is the Principal Investigator of the NCSC–EPSRC Academic Centre of Excellence in Cyber Security Research, University of Warwick, where he is a Professor of Cyber Systems Engineering with Warwick Manufacturing Group. He is also a Fellow of the Alan Turing Institute, the National Institute for Data Science, and AI in the U.K. where he is a Principal Investigator on a \$5 million project developing trustworthy national identity to enable financial inclusion.

**Andrew Larkins** is founder and CEO of Sygensys. He is working with a wide range of industry stakeholders, including grid operators, regulators, and OEMs to maximise the benefits of mass adoption of smart charging, vehicle to grid and other demand side response systems. Key to that activity is a focus on maintaining and enhancing energy system resilience in the presence of these emerging technologies. Previous experience includes developing innovative electronic products and IoT systems across multiple sectors from medical devices to semiconductors.

**Daryl Flack** is an expert in smart energy cyber security and specialises in consulting for the UK Government on large scale Smart Energy, Critical National Infrastructure (CNI) programmes. He is also the co-founder and CISO of BLOCKPHISH, a leading Managed Security Service Provider (MSSP) with a dedicated Energy Security Practice focused exclusively on mitigating cyber risks to organisations in the energy sector. Daryl is a published author, keynote speaker and is certified to the highest level by the National Cyber Security Centre (NCSC) - a part of GCHQ. He is also a Fellow at the Chartered Institute for Information Security (CIISEC) and has been awarded Chartered Cyber Security Professional status by the UK Cyber Security Council (UKCSC).

**Christopher Few** is a cyber risk assessor at National Grid and was previously a cyber researcher at Ofgem. Cyber security has been a theme through his career for over 30 years. His qualifications include membership of the Chartered Institute of Information Security and of the Institution of Engineering and Technology.

**Anurag K. Srivastava** is a Raymond J. Lane Professor and Chairperson of the Computer Science and Electrical Engineering Department at the West Virginia University. He is also an adjunct professor at the Washington State University and senior scientist at the Pacific Northwest National Lab. He received his Ph.D. degree in electrical engineering from the Illinois Institute of Technology in 2005. His research interest includes data-driven algorithms for power system operation and control including cyber-resiliency analysis. He is an IEEE Fellow, IEEE Distinguished lecturer and the author of more than 350 technical publications including a book and 3 patents.