SCALECRAFTER: TUNING-FREE HIGHER-RESOLUTION VISUAL GENERATION WITH DIFFUSION MODELS

Yingqing He^{*1,3}, Shaoshu Yang^{*2,3}, Haoxin Chen³, Xiaodong Cun³, Menghan Xia³,
Yong Zhang^{†3}, Xintao Wang³, Ran He², Qifeng Chen^{†1}, Ying Shan³

¹Hong Kong University of Science and Technology

²Chinese Academy of Sciences

³Tencent AI Lab

ABSTRACT

In this work, we investigate the capability of generating images from pre-trained diffusion models at much higher resolutions than the training image sizes. In addition, the generated images should have arbitrary image aspect ratios. When generating images directly at a higher resolution, 1024×1024 , with the pre-trained Stable Diffusion using training images of resolution 512×512 , we observe persistent problems of object repetition and unreasonable object structures. Existing works for higher-resolution generation, such as attention-based and joint-diffusion approaches, cannot well address these issues. As a new perspective, we examine the structural components of the U-Net in diffusion models and identify the crucial cause as the limited perception field of convolutional kernels. Based on this key observation, we propose a simple yet effective *re-dilation* that can dynamically adjust the convolutional perception field during inference. We further propose the dispersed convolution and noise-damped classifier-free guidance, which can enable *ultra-high-resolution* image generation (*e.g.*, 4096×4096). Notably, our approach *does not require any training or optimization*. Extensive experiments demonstrate that our approach can address the repetition issue well and achieve state-of-the-art performance on higher-resolution image synthesis, especially in texture details. Our work also suggests that a pre-trained diffusion model trained on low-resolution images can be directly used for high-resolution visual generation without further tuning, which may provide insights for future research on ultra-high-resolution image and video synthesis. More results are available at the project website: <https://yingqinghe.github.io/scalecrafter/>.

1 INTRODUCTION

In recent two years, the rapid development of image synthesis has attracted tremendous attention from both academia and industry, especially the most popular text-to-image generation models, such as Stable Diffusion (SD) (Rombach et al., 2022), SD-XL (Podell et al., 2023), Midjourney (Mid), and IF (IF). However, the highest resolution of these models is 1024×1024 , which is far from the demand of applications such as advertisements.

Directly sampling an image with a resolution beyond the training image sizes of those models will encounter severe object repetition issues and unreasonable object structures. As shown in Fig. 1, when using a Stable Diffusion (SD) model trained on images of 512×512 , to sample images of 512×1024 and 1024×1024 resolutions, the object repetition appears. The larger the image size, the more severe the repetition.

A few methods attempt to generate images with a larger size than the training image size of SD, *e.g.*, Multi-Diffusion (Bar-Tal et al., 2023) and SyncDiffusion (Lee et al., 2023). In Multi-Diffusion, images generated from multiple windows are fused using the averaged features across the windows

*Equal Contribution

†Corresponding Authors



Figure 1: Structure repetition issue of higher-resolution generation (Train: 512^2 ; Inference: 512×1024 and 1024^2). Altering the scaling factor of attention (Jin et al., 2023), and joint diffusion approaches including MultiDiffusion (Bar-Tal et al., 2023) and SyncDiffusion (Lee et al., 2023) fails to address this problem. While our simple *re-dilation* successfully solves this problem and yields structure and semantic correct images, and at meanwhile *require no optimization and tuning cost*.

in all the reverse steps. While SyncDiffusion improves the style consistency of Multi-Diffusion by using an anchor window. However, they focus on the smoothness of the overlap region and cannot solve the repetition issue, as shown in Fig. 1. Most recently, (Jin et al., 2023) studies the SD adaptation for variable-sized image generation through the view of attention entropy. However, their method has a negligible effect on the object repetition issue when increasing the inference resolution.

To investigate the pattern repetition, we sample a set of images of 1024^2 and 512^2 from the pre-trained SD model trained with 512^2 images for comparison. Zooming in on the images, we observe that the images of 1024^2 have no blur effects and the image quality does not degenerate like the Bilinear upsampling, though their object structures become worse. It indicates that the pre-trained SD model has the potential to generate higher-resolution images without sacrificing image definition.

We then delve into the structural components of SD to analyze their influence, *e.g.*, convolution, self-attention, cross-attention, etc. Surprisingly, when we change convolution to dilated convolution in the whole U-Net using the pre-trained parameters, the overall structure becomes reasonable, *i.e.*, the object repetition disappears. However, the repetition happens to local edges. We then carefully analyze *where*, *when*, and *how* to apply the dilated convolution, *i.e.*, the influence of U-Net blocks, timesteps, and dilation radius. Based on these studies, we propose a tuning-free dynamic re-dilation strategy to solve the repetition. However, as the resolution further increases (*e.g.*, 16x), the decreased generated quality and denoising ability arise. To tackle it, we then propose novel dispersed convolution and noise-damped classifier-free guidance for ultra-high-resolution generation.

Our main contributions are as follows:

- We observe that the primary cause of the object repetition issue is the limited convolutional receptive field rather than the attention token quantity, providing a new viewpoint compared to the prior works.



Figure 2: Our method can generate 4096×4096 images, $16\times$ higher than the training resolution.

- Based on this observation, we propose the simple yet effective *re-dilation* for dynamically increasing the receptive field during inference time. We also propose *dispersed convolution* and *noise-damped classifier-free guidance* for ultra-high-resolution generation.
- We empirically evaluate our approach on various diffusion models, including different versions of Stable Diffusion, and a text-to-video model, with varying image resolutions and aspect ratios, demonstrating the effectiveness of our model.

2 RELATED WORK

2.1 TEXT-TO-IMAGE SYNTHESIS

Text-to-image synthesis has gained remarkable attention recently due to its impressive generation performance (Saharia et al., 2022; Ramesh et al., 2022; Chang et al., 2023; Ding et al., 2022). Among various generative models, diffusion models are popular for their high-quality generation capabilities (Xing et al., 2023; He et al., 2022b; Ho et al., 2022a). Following the groundbreaking work of DDPM (Ho et al., 2020), numerous studies have focused on diffusion models for image generation (Nichol et al., 2021; Nichol & Dhariwal, 2021; Kingma & Ba, 2014; Ho et al., 2022b; Rombach et al., 2022; Ramesh et al., 2022; Gu et al., 2022). In particular, Latent diffusion models (LDM) (Rombach et al., 2022) have become widely used, as their compact latent space improves model efficiency. Subsequently, a series of Stable Diffusion (SD) models are open-sourced, building upon LDMs and offering high sample quality and creativity. Despite their impressive synthesis capabilities, the

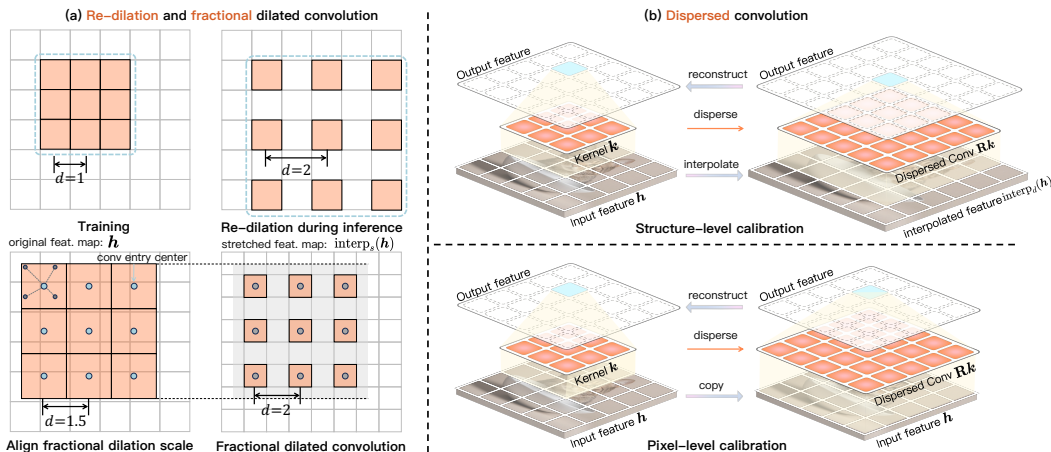

Figure 3: (a) The first row shows re-dilation. Given a pre-trained kernel trained on low-resolution data, we fix the parameters and insert spaces into kernel elements during test time. The second row shows fractional dilated convolution. For each entry of the convolution kernel, we compute the input feature with features near the kernel entry center with bilinear interpolation. This is equivalent to stretch input feature maps and uses a rounded-up dilation scale before the convolution operation. (b) Dispersed convolution can enlarge a pre-trained kernel with a specific scale. We use structure-level calibration to adapt to a new perception field when the input feature dimension is larger and use pixel-level calibration to preserve local information processing ability.

resolution remains limited to the training resolution, *e.g.*, 512^2 for SD 2.1 and 1024^2 for SD XL, necessitating a mechanism for higher resolution generation (*e.g.*, 2K, 4K, etc.).

2.2 HIGH-RESOLUTION SYNTHESIS AND ADAPTATION

High-resolution image synthesis is challenging due to the difficulty of learning from higher-dimensional data and the substantial requirement of computational resources. Prior work can mainly be divided into two categories: *training from scratch* (Teng et al., 2023; Hoogeboom et al., 2023; Chen, 2023) and *fine-tuning* (Zheng et al., 2023; Xie et al., 2023). Most recently, (Jin et al., 2023) studies a training-free approach for variable-sized adaptation. However, it fails to tackle the case of higher-resolution generation. Multi-Diffusion (Bar-Tal et al., 2023) and SyncDiffusion (Lee et al., 2023) focus on smoothing the overlap region to avoid inconsistency between windows. However, object repetition still exists in their results. MultiDiffusion can avoid repetition by using the conditions such as region and text from the user. However, those extra inputs are not available in the scenario of text-to-image generation. Differently, we propose a tuning-free method from the perspective of the network structure that can fundamentally solve the object repetition issue in higher-resolution image synthesis.

3 METHOD

3.1 PROBLEM FORMULATION AND MOTIVATION

Without the loss of generality, the formulation of this paper considers the ϵ -prediction paradigm of diffusion models. Given a base diffusion model $\epsilon_\theta(\cdot)$ parameterized by θ . It is trained on a fixed pre-defined low-resolution image $x \in \mathbb{R}^{3 \times h \times w}$, our goal is to adapt the model to $\tilde{\epsilon}_\theta(\cdot)$ in a training-free manner to synthesize higher resolution images $\tilde{x} \in \mathbb{R}^{3 \times H \times W}$.

A previous work (Jin et al., 2023) attributes the degradation of performance to the change in the number of attention tokens and proposes to scale the features in the self-attention layer according to the input resolution. However, when applying it to generate 1024^2 images, the object repetition is still there (see Fig. 1). We observe that the local structure of each repetitive object seems reasonable

and the unreasonable part is the object number when the resolution increases. This encourages us to investigate whether the receptive field of any network component does not fit the larger resolution.

Hence, we modify the components of the SD U-Net to analyze their influence, such as attention, convolution, normalization, etc. We develop *re-dilation* to dissect the effect of the receptive field of attention and convolution, respectively. Re-dilation aims to adjust the network receptive field on a higher-resolution image to maintain the same as the original lower-resolution generation. For re-dilated attention, we partition the feature map into slices with each slice collected via a feature dilation having the same token quantity as training. Then, these slices are fed into the QKV attention in parallel, after which they are merged into the original arrangement. Details are illustrated in the supplementary. However, maintaining the receptive field of attention yields results with indistinguishable differences compared with direct inference. Differently, when increasing the receptive field of convolution in all blocks of the U-Net, fortunately, we observe that the number of objects is correct though there are many artifacts such as noisy background and repetitive edges. Based on the observation, we then develop a more elaborate re-dilation strategy considering where, when, and how to apply dilated convolution.

3.2 RE-DILATION

Note that we ignore the feature channel dimension and convolution bias for simplicity in the following. Considering a hidden feature $\mathbf{h} \in \mathbb{R}^{m \times n}$ before a convolution layer $f_{\mathbf{k}}(\cdot)$ of the network. Given the convolution kernel $\mathbf{k} \in \mathbb{R}^{r \times r}$ and the dilation operation $\Phi_d(\cdot)$ with factor d . The dilated convolution $f_{\mathbf{k}}^d(\cdot)$ is computed with

$$f_{\mathbf{k}}^d(\mathbf{h}) = \mathbf{h} \otimes \Phi_d(\mathbf{k}), (\mathbf{h} \otimes \Phi_d(\mathbf{k}))(o) = \sum_{s+d \cdot t=p} \mathbf{h}(p) \cdot \mathbf{k}(q), \quad (1)$$

where o, p, q are spatial locations used to index the feature and kernel, \otimes denotes convolution operation. Notably, different from traditional dilated convolutions, which share a common dilation factor during training and inference. Our proposed approach dynamically adjusts the dilation factor *only in inference time*, leading us to term it as *re-dilation*. Since the dilation factor can only be an integer, traditional dilated convolution cannot address a fractional multiple of the perception field (i.e. $1.5 \times$). We propose *fractional dilated convolution*. Without a loss of information, we round up the target scale to an integer dilation factor and stretch the input feature map to a size where the perception field meets the requirement. Specifically, let s denote the stretch scale and let $\text{interp}_s(\cdot)$ denote a resizing interpolation function (i.e., bilinear interpolation) with scale s . We upsample the feature \mathbf{h} with the stretch scale to $\text{interp}_s(\mathbf{h})$. The new re-dilation supporting fractional dilation factors is computed as follows:

$$f_{\mathbf{k}}^d(\mathbf{h}) = \text{interp}_{1/s}(\text{interp}_s(\mathbf{h}) \otimes \Phi_{\lceil d \rceil}(\mathbf{k})), s = \lceil d \rceil / d, \quad (2)$$

where $\lceil \cdot \rceil$ is the round-up operator. A visualization of re-dilated convolution is shown in Fig. 3. Considering the properties of the diffusion model with T timesteps and L layers, we further generalize the re-dilation factor to become layer-and-timestep-aware, yielding $d = D(t, l)$, where $t \in [0, T - 1], l \in [0, L - 1]$, and D is a pre-defined dilation schedule function. Empirically, we find that the re-dilation achieves better synthesis quality when the dilation radius is progressively decreased from deep layers to shallow layers, as well as from noisier steps to less noisy steps, than the fixed dilation factor across all timesteps and layers.

3.3 CONVOLUTION DISPERSION

Unfortunately, re-dilated convolution suffers from the periodic downsampling problem (e.g., grinding artifacts) (Wang & Ji, 2018), i.e., the features will not consider information from a different dilated convolution split. This problem arises when adapting a diffusion model to generate much higher resolution. To alleviate the problem, we propose to increase the receptive field of a pre-trained convolution layer by dispersing its convolution kernel. Our *convolution dispersion* method is shown in Fig. 3. Given a convolution layer with kernel $\mathbf{k} \in \mathbb{R}^{r \times r}$ and a target kernel size r' (if the required perception field multiple is d and r is odd, then $r' = d(r - 1) + 1$), our method applies a linear transform $\mathbf{R} \in \mathbb{R}^{r'^2 \times r^2}$ to get a dispersed kernel $\mathbf{k}' = \mathbf{R}\mathbf{k}$. We apply *structure-level* and *pixel-level calibration* to enlarge the convolution kernel while keeping the capability of the original convolution layer.

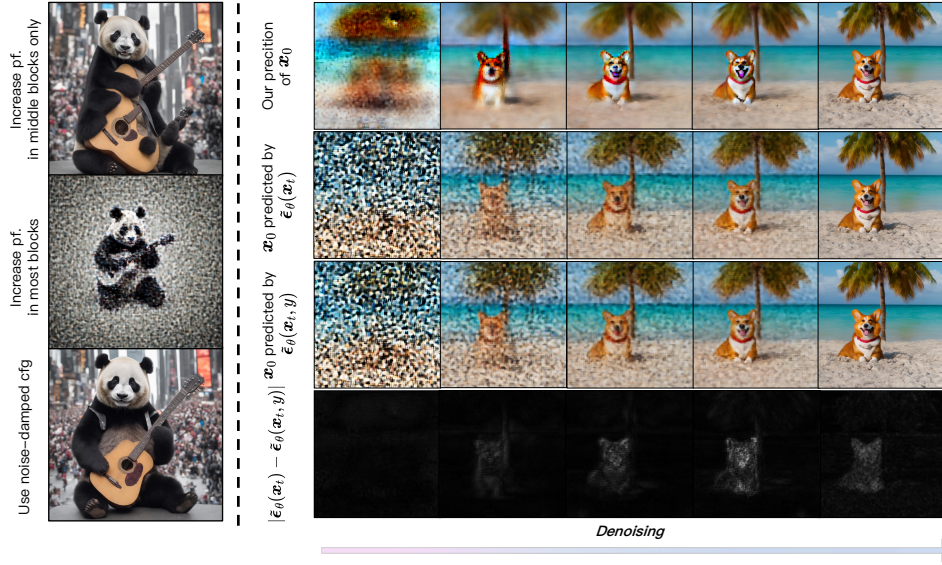

Figure 4: **left**: Samples by increasing perception field in middle blocks and most blocks (middle and outskirt blocks). The middle blocks-only setting fails to produce the correct small object structures. **right**: The first row shows the predicted original sample using noise-damped classifier-free guidance. The second and third rows show the prediction using $\tilde{\epsilon}_\theta(\mathbf{x}_t, y)$ and $\tilde{\epsilon}_\theta(\mathbf{x}_t)$. $\tilde{\epsilon}_\theta(\mathbf{x}_t, y)$ and $\tilde{\epsilon}_\theta(\mathbf{x}_t)$ fails to remove noise during sampling. However, their predictions exhibit a very similar noise pattern. The fourth row illustrates $|\tilde{\epsilon}_\theta(\mathbf{x}_t, y) - \tilde{\epsilon}_\theta(\mathbf{x}_t)|$. The erroneous noise prediction vanishes and we can utilize the remaining useful information.

We use *structure-level calibration* to preserve the performance of a pre-trained convolution layer when the size of the input feature map changes. Consider an arbitrary convolution layer $f_{\mathbf{k}}(\cdot)$ and the input feature map \mathbf{h} . Structure-level calibration requires the following equation:

$$\text{interp}_d(f_{\mathbf{k}}(\mathbf{h})) = f_{\mathbf{k}'}(\text{interp}_d(\mathbf{h})), \mathbf{k}' = \mathbf{R}\mathbf{k} \quad (3)$$

where $f_{\mathbf{k}'}(\cdot)$ receives the interpolated feature map and keeps its output the same as the interpolated original output $\text{interp}_d(f_{\mathbf{k}}(\mathbf{h}))$. Eqn. 3 is underdetermined since the enlarged kernel \mathbf{k}' has more elements than \mathbf{k} . To solve this equation, we introduce *pixel-level calibration* to ensure the enlarged new convolution kernel behaves similarly on the original feature map \mathbf{h} . Mathematically, pixel-level calibration requires $f_{\mathbf{k}}(\mathbf{h}) = f_{\mathbf{k}'}(\mathbf{h})$. Then, we combine this with Eqn. 3 to formulate a linear least square problem:

$$\mathbf{R} = \min_{\mathbf{R}} \|\text{interp}_d(f_{\mathbf{k}}(\mathbf{h})) - f_{\mathbf{k}'}(\text{interp}_d(\mathbf{h}))\|_2^2 + \eta \cdot \|f_{\mathbf{k}}(\mathbf{h}) - f_{\mathbf{k}'}(\mathbf{h})\|_2^2 \quad (4)$$

where η is a weight controlling the focus of dispersed convolution. We derive an enlarged kernel with convolution dispersion by solving the least square problem. Note that \mathbf{R} is not relevant to the exact numerical value of the input feature or the kernel. One can apply it to any convolution kernels to enlarge it from $r \times r$ to $r' \times r'$. Convolution dispersion can be used along with the re-dilation technique to achieve a much larger perceptual field without suffering from the periodic sub-sampling problem. To achieve a fractional perception field scale factor, we replace the dilation operation with convolution dispersion in fractional dilated convolution introduced above.

3.4 NOISE-DAMPED CLASSIFIER-FREE GUIDANCE

To sample at a much higher resolution (*i.e.*, $4\times$ in both height and width), we need to increase the perception field in the outer blocks in the denoising U-Net to generate the correct structure in small objects as shown in Fig. 4. However, we find that the outside block in the U-Net contributes a lot to estimating the noise contained in the input. When we try to increase the convolution perceptual field in these blocks, the denoising capability of the model is damaged. As a result, it is challenging to generate the correct small structures while maintaining the denoising ability of the original model.

Res	Method	SD 1.5				SD 2.1				SD XL 1.0			
		FID _r	KID _r	FID _b	KID _b	FID _r	KID _r	FID _b	KID _b	FID _r	KID _r	FID _b	KID _b
4× 1:1	Direct-Inf	38.50	0.014	29.30	0.008	29.89	0.010	24.21	0.007	67.71	0.029	45.55	0.014
	Attn-SF	38.59	0.013	29.30	0.008	28.95	0.010	22.75	0.007	68.93	0.028	46.07	0.013
	Ours	32.67	0.012	24.93	0.007	20.88	0.008	16.67	0.005	64.75	0.024	28.15	0.009
6.25× 1:1	Direct-Inf	55.47	0.020	48.54	0.015	52.58	0.018	48.13	0.014	93.91	0.041	54.90	0.020
	Attn-SF	55.96	0.020	49.03	0.015	50.62	0.017	45.57	0.014	93.92	0.042	54.89	0.019
	Ours	52.11	0.019	45.86	0.014	33.36	0.010	30.66	0.008	80.72	0.032	47.15	0.015
8× 1:2	Direct-Inf	74.52	0.032	68.98	0.027	69.89	0.029	55.48	0.020	122.41	0.062	82.51	0.037
	Attn-SF	74.42	0.032	68.81	0.027	68.97	0.029	53.97	0.020	122.21	0.062	82.35	0.037
	Ours	58.21	0.022	52.76	0.017	58.57	0.021	49.41	0.015	119.58	0.057	50.70	0.019
16× 1:1	Direct-Inf	111.34	0.046	106.70	0.042	104.70	0.043	104.10	0.040	153.33	0.070	144.99	0.061
	Attn-SF	110.10	0.046	105.42	0.042	104.34	0.043	103.61	0.041	153.68	0.070	144.84	0.061
	Ours	78.22	0.027	65.86	0.023	59.40	0.021	57.26	0.018	131.03	0.063	124.01	0.055

Table 1: Quantitative comparisons among training-free methods.

We propose *noise-damped classifier-free guidance* to address the difficulties. Our method incorporates the two model priors, a model with strong denoising capabilities $\epsilon_\theta(\cdot)$, and a model that uses re-dilated or dispersed convolution in most blocks that generates great image content structures $\tilde{\epsilon}_\theta(\cdot)$. Then, the sampling process is performed using a linear combination of the estimations with guidance scale w :

$$\epsilon_\theta(\mathbf{x}_t) + w \cdot (\tilde{\epsilon}_\theta(\mathbf{x}_t, y) - \tilde{\epsilon}_\theta(\mathbf{x}_t)), \quad (5)$$

where y is the input text prompt. Eqn. 5 includes a base prediction $\epsilon_\theta(\mathbf{x}_t)$ that ensures effective denoising during the sampling process. The guidance term $\tilde{\epsilon}_\theta(\mathbf{x}_t, y) - \tilde{\epsilon}_\theta(\mathbf{x}_t)$ includes two poor noise predictions. However, in Fig. 4, our experiments demonstrate that the erroneous noise predictions in $\tilde{\epsilon}_\theta(\mathbf{x}_t)$ and $\tilde{\epsilon}_\theta(\mathbf{x}_t, y)$ are very similar. Such erroneous noise prediction vanishes in the results of $\tilde{\epsilon}_\theta(\mathbf{x}_t, y) - \tilde{\epsilon}_\theta(\mathbf{x}_t)$, and the remaining information is useful for generating correct object structures.

4 EXPERIMENTS

Experiment setup. We conducted evaluation experiments on text-to-image models, Stable Diffusion (SD), including three prevalent versions: SD 1.5 (Rombach et al., 2022), SD 2.1 (Diffusion, 2022), and SD XL 1.0 (Podell et al., 2023) in inferring four unseen higher resolutions. We experimented with four resolution settings, which are 4 times, 6.25 times, 8 times, and 16 times more pixels than the training. Specifically, for both SD 1.5 and SD 2.1, the training size is 512^2 , and the inference resolutions are 1024^2 , 1280^2 , 2048×1024 , 2048^2 , respectively. For SD XL, the training resolution is 1024^2 , and the inference resolutions are 2048^2 , 2560^2 , 4096×2048 , 4096^2 . We also evaluate our approach on a text-to-video model for 2 times higher resolution generation. Please see our supplementary for the detailed hyperparameter settings.

Testing dataset and evaluation. We evaluate performance on the dataset of Laion-5B (Schuhmann et al., 2022) which contains 5 billion image-caption pairs. When the inference resolution is 1024^2 , we sample 30k images with randomly sampled text prompts from the dataset. Due to massive computation, we sample 10k images when the inference resolution is higher than 1024^2 . In main evaluations, we experiment with a normal higher resolution setting (4×, 1:1), a fractional scaling resolution (6.25, 1:1), a varied aspect ratio (8×, 1:2), and an extreme higher resolution (16×, 1:1). In other experiments, we evaluate the metrics with the aspect ratio of 1:1 unless otherwise specified. Following the standard evaluation protocol, we measure the Frechet Inception Distance (FID) and Kernel Inception Distance (KID) between generated images and real images to evaluate the generated image quality and diversity, referred to as FID_r and KID_r. We adopt the implementation of clean-fid (Parmar et al., 2022) to avoid discrepancies in the image pre-processing steps. Since the pre-trained models have the capability of compositing different concepts that do not appear in the training set, we also measure the metrics between the generated samples under the base training resolution and inference resolution, referred to as FID_b and KID_b. This evaluates how well our method can preserve the model’s original ability when sampling under a new resolution.

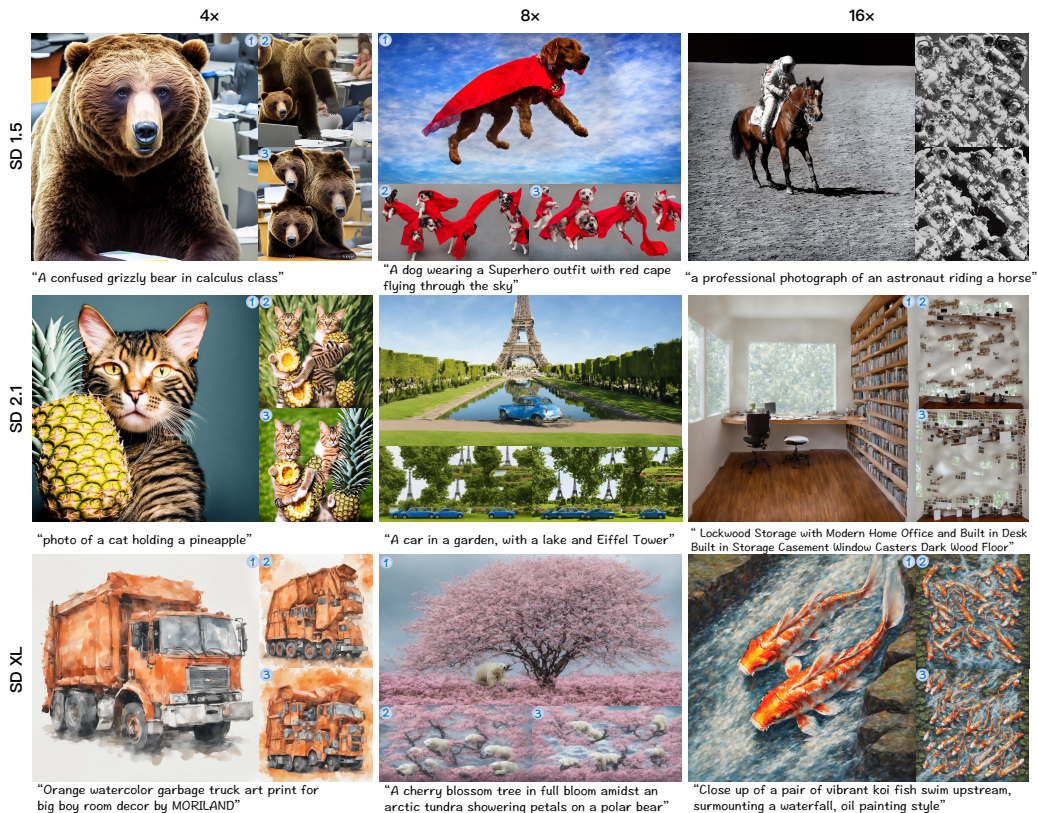

Figure 5: Visual comparisons between ① ours, ② directly inferencing SD and ③ Attn-SF (Jin et al., 2023) in 4x, 8x and 16x settings and three Stable Diffusion models.

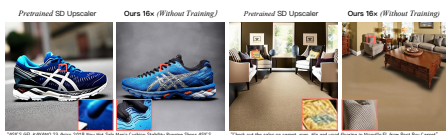

Figure 6: Visual comparisons with SD-SR.

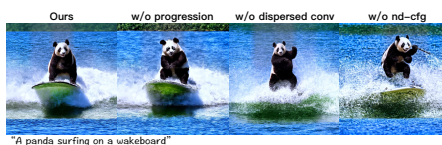

Figure 7: Qualitative ablation results.

4.1 EVALUATION

Comparison with training-free methods. We compare our method with the vanilla text-to-image diffusion model (Direct-Inf) and a tuning-free method (Jin et al., 2023) via altering the attention scaling factor (Attn-SF). As Multi-Diffusion (Bar-Tal et al., 2023) and SyncDiffusion (Lee et al., 2023) cannot alleviate the repetition issue, they are not compared here. Our results are shown in Tab. 1. Compared to baselines, we achieve better metric scores in all experiment settings. It indicates our method preserves the original generation ability of a pre-trained diffusion model much better. Visual comparisons are shown in Fig. 5.

Due to the inappropriate convolution perception field, direct inference and Attn-SF tend to generate small repeated contents, resulting in unnatural image structure. On the contrary, our method can generate plausible structures and highly detailed textures in unseen image resolutions.

Comparison with the diffusion super-resolution model (SR). Although our approach does not require any extra datasets or extensive training efforts. To comprehensively evaluate our performance, we compare our approach with a pre-trained Stable Diffusion super-resolution (SD-SR) model: SD 2.1-upscaler-4x (Ups) at 4x and 16x higher resolution generation. Both our approach and the upscaler are combined with the Stable Diffusion 2.1-512². Qualitative and quantitative results are shown in Fig. 6 and Tab. 2. As seen in Fig. 6, our method synthesizes better fine-grained



Figure 8: Our approach can also be applied to higher-resolution (4x) text-to-video (T2V) generation.

Method	FID _r -4×	KID _r -4×	TD-16×
SD+SR	12.59	0.005	38%
Ours	20.88	0.008	62%

Table 2: Quantitative comparisons with SR.

Method	FVD _r -4×	KVD _r -4×
Direct Inference	674.14	78.31
Ours	418.80	31.78

Table 3: Quantitative results on T2V.

details and textures such as the shoes and cushion. Note that the calculation of FID and KID requires image downsampling to 229×229 which cannot measure the definition of detailed texture. Hence, we perform a user preference study on the $16 \times$ setting to ask users to choose an image with a better texture definition between ours and SD Upscaler. The responses of 300 questions are collected. We summarize the results with the percentage of the user’s choices, referred to as Texture Definition (TD) (4th column in the Tab. 2). Our FID and KID are slightly worse than the pretrained SD-SR; However, our approach synthesizes high-resolution images with a lower-resolution generative model *in a single stage, and without any extra training*, while the SR model requires a large amount of data and computation to train and tends to exhibit *worse texture details*. This demonstrates that the pre-trained Stable Diffusion model already learns the rich texture priors. With proper utilization, we can leverage this prior to synthesizing high-quality and higher-resolution images.

4.2 ABLATION STUDY

Method	FID _r -16×	KID _r -16×
Ours	78.22	0.027
w/o progression	94.90	0.040
w/o conv dispersion	106.18	0.051
w/o nd-cfg	112.15	0.055

Table 4: Ablation study on SD 1.5.

ensures less noise in the final image, and dispersed convolution improves the fidelity of object structures. Tab. 4 shows quantitative results. Without these components, the FID performance dropped by 16.68, 27.96, and 33.93, respectively. Therefore, every technical component of our method brings considerable improvements.

4.3 APPLY ON VIDEO DIFFUSION MODELS

To verify the generalization ability of our method for video generation models, we apply it to a pre-trained text-to-video model, LVDM (He et al., 2022a). As shown in Fig. 8, our method can generate higher-resolution videos without image definition degeneration. The quantitative results are in Tab. 3. Metrics are computed using the video counterpart Frechet Video Distance (FVD) (Unterthiner et al., 2018) and Kernel Video Distance (KVD) (Unterthiner et al., 2019) with 2048 sampled videos and are evaluated on the Webvid-10M (Bain et al., 2021).

5 CONCLUSIONS

We investigate the possibility of sampling images at a much higher resolution than the training resolution of pre-trained diffusion models. Directly sampling a higher resolution image can preserve the image definition but will encounter the severe object repetition issue. We delve into the architecture of the SD U-Net and explore the receptive field of its components. Fortunately, we observe that convolution is critical for sampling higher-resolution images. We then propose an elaborate dynamic re-dilation strategy to remove the repetition and also propose the dispersed convolution and noise-damped classifier-free guidance for ultra-high-resolution generation. Evaluations are conducted to demonstrate the effectiveness of our methods for different text-to-image and text-to-video models.

REFERENCES

- If. URL <https://github.com/deep-floyd/IF>. Accessed: 9 28, 2023.
- Midjourney. URL <https://www.midjourney.com/showcase/recent/>. Accessed: 9 28, 2023.
- Upscaler. URL <https://huggingface.co/stabilityai/stable-diffusion-x4-upscaler>. Accessed: 9 29, 2023.
- Max Bain, Arsha Nagrani, Gül Varol, and Andrew Zisserman. Frozen in time: A joint video and image encoder for end-to-end retrieval. In *Proceedings of the IEEE/CVF International Conference on Computer Vision*, pp. 1728–1738, 2021.
- Omer Bar-Tal, Lior Yariv, Yaron Lipman, and Tali Dekel. Multidiffusion: Fusing diffusion paths for controlled image generation. 2023.
- Huiwen Chang, Han Zhang, Jarred Barber, AJ Maschinot, Jose Lezama, Lu Jiang, Ming-Hsuan Yang, Kevin Murphy, William T Freeman, Michael Rubinstein, et al. Muse: Text-to-image generation via masked generative transformers. *arXiv preprint arXiv:2301.00704*, 2023.
- Ting Chen. On the importance of noise scheduling for diffusion models. *arXiv preprint arXiv:2301.10972*, 2023.
- Stable Diffusion. Stable diffusion 2-1 base. https://huggingface.co/stabilityai/stable-diffusion-2-1-base/blob/main/v2-1_512-ema-pruned.ckpt, 2022.
- Ming Ding, Wendi Zheng, Wenyi Hong, and Jie Tang. Cogview2: Faster and better text-to-image generation via hierarchical transformers. *Advances in Neural Information Processing Systems*, 35:16890–16902, 2022.
- Shuyang Gu, Dong Chen, Jianmin Bao, Fang Wen, Bo Zhang, Dongdong Chen, Lu Yuan, and Baining Guo. Vector quantized diffusion model for text-to-image synthesis. In *Proceedings of the IEEE/CVF Conference on Computer Vision and Pattern Recognition*, pp. 10696–10706, 2022.
- Yingqing He, Tianyu Yang, Yong Zhang, Ying Shan, and Qifeng Chen. Latent video diffusion models for high-fidelity video generation with arbitrary lengths. *arXiv preprint arXiv:2211.13221*, 2022a.
- Yingqing He, Tianyu Yang, Yong Zhang, Ying Shan, and Qifeng Chen. Latent video diffusion models for high-fidelity video generation with arbitrary lengths. *arXiv preprint arXiv:2211.13221*, 2022b.
- Jonathan Ho, Ajay Jain, and Pieter Abbeel. Denoising diffusion probabilistic models. *Advances in Neural Information Processing Systems*, 33:6840–6851, 2020.
- Jonathan Ho, William Chan, Chitwan Saharia, Jay Whang, Ruiqi Gao, Alexey Gritsenko, Diederik P Kingma, Ben Poole, Mohammad Norouzi, David J Fleet, et al. Imagen video: High definition video generation with diffusion models. *arXiv preprint arXiv:2210.02303*, 2022a.

-
- Jonathan Ho, Chitwan Saharia, William Chan, David J Fleet, Mohammad Norouzi, and Tim Salimans. Cascaded diffusion models for high fidelity image generation. *J. Mach. Learn. Res.*, 23: 47–1, 2022b.
- Emiel Hooeboom, Jonathan Heek, and Tim Salimans. simple diffusion: End-to-end diffusion for high resolution images. *arXiv preprint arXiv:2301.11093*, 2023.
- Zhiyu Jin, Xuli Shen, Bin Li, and Xiangyang Xue. Training-free diffusion model adaptation for variable-sized text-to-image synthesis. *arXiv preprint arXiv:2306.08645*, 2023.
- Diederik P Kingma and Jimmy Ba. Adam: A method for stochastic optimization. *arXiv preprint arXiv:1412.6980*, 2014.
- Yuseung Lee, Kunho Kim, Hyunjin Kim, and Minhyuk Sung. Syncdiffusion: Coherent montage via synchronized joint diffusions. *arXiv preprint arXiv:2306.05178*, 2023.
- Alex Nichol, Prafulla Dhariwal, Aditya Ramesh, Pranav Shyam, Pamela Mishkin, Bob McGrew, Ilya Sutskever, and Mark Chen. Glide: Towards photorealistic image generation and editing with text-guided diffusion models. *arXiv preprint arXiv:2112.10741*, 2021.
- Alexander Quinn Nichol and Prafulla Dhariwal. Improved denoising diffusion probabilistic models. In *International Conference on Machine Learning*, pp. 8162–8171. PMLR, 2021.
- Gaurav Parmar, Richard Zhang, and Jun-Yan Zhu. On aliased resizing and surprising subtleties in gan evaluation. In *Proceedings of the IEEE/CVF Conference on Computer Vision and Pattern Recognition*, pp. 11410–11420, 2022.
- Dustin Podell, Zion English, Kyle Lacey, Andreas Blattmann, Tim Dockhorn, Jonas Müller, Joe Penna, and Robin Rombach. Sdxl: improving latent diffusion models for high-resolution image synthesis. *arXiv preprint arXiv:2307.01952*, 2023.
- Aditya Ramesh, Prafulla Dhariwal, Alex Nichol, Casey Chu, and Mark Chen. Hierarchical text-conditional image generation with clip latents. *arXiv preprint arXiv:2204.06125*, 2022.
- Robin Rombach, Andreas Blattmann, Dominik Lorenz, Patrick Esser, and Björn Ommer. High-resolution image synthesis with latent diffusion models. In *Proceedings of the IEEE/CVF Conference on Computer Vision and Pattern Recognition*, pp. 10684–10695, 2022.
- Chitwan Saharia, William Chan, Saurabh Saxena, Lala Li, Jay Whang, Emily Denton, Seyed Kamyar Seyed Ghasemipour, Burcu Karagol Ayan, S Sara Mahdavi, Rapha Gontijo Lopes, et al. Photorealistic text-to-image diffusion models with deep language understanding. *arXiv preprint arXiv:2205.11487*, 2022.
- Christoph Schuhmann, Romain Beaumont, Richard Vencu, Cade Gordon, Ross Wightman, Mehdi Cherti, Theo Coombes, Aarush Katta, Clayton Mullis, Mitchell Wortsman, Patrick Schramowski, Srivatsa Kundurthy, Katherine Crowson, Ludwig Schmidt, Robert Kaczmarczyk, and Jenia Jitsev. Laion-5b: An open large-scale dataset for training next generation image-text models, 2022.
- Jiayan Teng, Wendi Zheng, Ming Ding, Wenyi Hong, Jianqiao Wangni, Zhuoyi Yang, and Jie Tang. Relay diffusion: Unifying diffusion process across resolutions for image synthesis. *arXiv preprint arXiv:2309.03350*, 2023.
- Thomas Unterthiner, Sjoerd van Steenkiste, Karol Kurach, Raphael Marinier, Marcin Michalski, and Sylvain Gelly. Towards accurate generative models of video: A new metric & challenges. *arXiv preprint arXiv:1812.01717*, 2018.
- Thomas Unterthiner, Sjoerd van Steenkiste, Karol Kurach, Raphael Marinier, Marcin Michalski, and Sylvain Gelly. Towards accurate generative models of video: A new metric & challenges. *ICLR*, 2019.
- Zhengyang Wang and Shuiwang Ji. Smoothed dilated convolutions for improved dense prediction. In *Proceedings of the 24th ACM SIGKDD International Conference on Knowledge Discovery & Data Mining*, pp. 2486–2495, 2018.

Enze Xie, Lewei Yao, Han Shi, Zhili Liu, Daquan Zhou, Zhaoqiang Liu, Jiawei Li, and Zhenguo Li. DiffFit: Unlocking transferability of large diffusion models via simple parameter-efficient fine-tuning. *arXiv preprint arXiv:2304.06648*, 2023.

Jinbo Xing, Menghan Xia, Yuxin Liu, Yuechen Zhang, Yong Zhang, Yingqing He, Hanyuan Liu, Haoxin Chen, Xiaodong Cun, Xintao Wang, et al. Make-your-video: Customized video generation using textual and structural guidance. *arXiv preprint arXiv:2306.00943*, 2023.

Qingping Zheng, Yuanfan Guo, Jiankang Deng, Jianhua Han, Ying Li, Songcen Xu, and Hang Xu. Any-size-diffusion: Toward efficient text-driven synthesis for any-size hd images. *arXiv preprint arXiv:2308.16582*, 2023.

A EXPERIMENT DETAILS

A.1 MODEL LAYERS IN OUR METHOD

The U-Net of Stable Diffusion (SD) v1.5, SD 2.1, and SD XL 1.0 share a similar convolution layer layout. We explain which layer to use re-dilated or dispersed convolutions without a loss of generality. We follow the naming of layers in diffusers¹. A list of convolution layers contained in a U-Net block is shown in Tab. 5. The attention projection layers and convolution shortcut layers will not use re-dilation or dispersion since the convolution kernel in these layers is 1×1 . Note that the first and the last convolution in the U-Net (conv_in and conv_out) will not use our method since they do not contribute to generating image contents. Also, the spatial part of the text-to-video model we used shares the same architecture as the SD. Therefore, layers of the following mentioned are also the same as our video experiment.

Layer name	Exist in all blocks	Use our method
attentions.0.proj_in	✓	✗
attentions.0.proj_out	✓	✗
attentions.1.proj_in	✗	✗
attentions.1.proj_out	✗	✗
attentions.2.proj_in	✗	✗
attentions.2.proj_out	✗	✗
resnets.0.conv1	✓	✓
resnets.0.conv2	✓	✓
resnets.0.conv_shortcut	✗	✗
resnets.1.conv1	✓	✓
resnets.1.conv2	✓	✓
downsamplers.0.conv	✗	✓

Table 5: The layers to use our method in a U-Net block. The second column shows the existence condition since some layers cannot be seen in specific U-Net blocks.

A.2 HYPERPARAMETERS

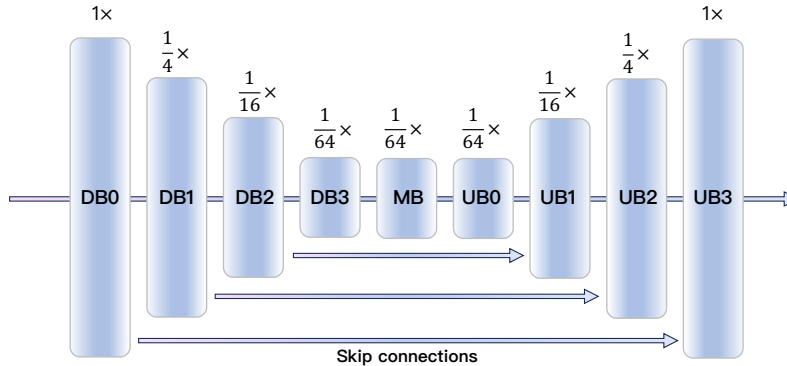

Figure 9: Reference block names in the following experiment details. The fractional multiples above blocks are the spatial size of feature maps within the block compared to the network input. i.e, the input latent has 64^2 spatial dimension, then the size of feature maps in MB3 is 8^2 .

¹<https://github.com/huggingface/diffusers>

We explain our selection for hyperparameters in this section. All samples are generated using the default classifier-free guidance scale of the corresponding pre-trained model (i.e. SD 1.5 and SD 2.1 use 7.5, SD XL 1.0 uses 5.0). Our SD 2.1 experiments use a similar setting to SD 1.5. We list the hyperparameters for SD 1.5 only for brevity. The evaluation settings for SD 1.5 are shown in Tab. 6, 7, 8, 9. The settings for SD XL 1.0 are shown in Fig. 10, 11, 12, 13. A reference for block names and their exact location in the U-Net can be found in Fig. 9. The tables show detailed settings about which block to use re-dilation conv and dispersed conv. Dilation scale rb. means the dilation scale for re-dilated blocks and dilation scale db. defines the dilation scale for dispersed blocks. If the sampling uses noise-damped classifier-free guidance, we construct a $\epsilon_\theta(\cdot)$ with strong denoising capability by turning some outskirts blocks that use re-dilated and dispersed convolution to the original blocks. The chosen ones that become the original blocks are listed in noise-damped blocks.

Params	Values	Params	Values
latent resolution	$4 \times 128 \times 128$	latent resolution	$4 \times 160 \times 160$
re-dilated blocks	[DB3, MB, UB0]	re-dilated blocks	[DB3, MB, UB0]
dilation scale rb.	[2, 2, 2]	dilation scale rb.	[2.5, 2.5, 2.5]
dispersed blocks	\emptyset	dispersed blocks	\emptyset
progressive	\times	progressive	\times
noise-damped cfg.	\times	noise-damped cfg.	\times
inference timesteps	50	inference timesteps	50
τ	30	τ	30

Table 6: 1024^2 SD 1.5 experiment settings.

Table 7: 1280^2 SD 1.5 experiment settings.

Params	Values
latent resolution	$4 \times 128 \times 256$
re-dilated blocks	[DB0, DB1, DB2, DB3, MB, UB0, UB1, UB2, UB3]
dilation scale rb.	[2, 2, 2, 2, 2, 2, 2, 2]
dispersed blocks	\emptyset
progressive	\times
noise-damped cfg.	\checkmark
noise-damped blocks	[DB0, DB1, DB2, UB1, UB2, UB3]
inference timesteps	50
τ	30

Table 8: 2048×1024 SD 1.5 experiment settings.

Params	Values
latent resolution	$4 \times 256 \times 256$
re-dilated blocks	[DB0, DB1, UB2, UB3]
dilation scale rb.	[2, 4, 4, 2]
dispersed blocks	[DB2, DB3, MB, UB0, UB1]
dilation scale db.	[2, 2, 2, 2, 2]
dispersed kernel size	$3 \times 3 \rightarrow 5 \times 5$
progressive	\checkmark
noise-damped cfg.	\checkmark
noise-damped blocks	[DB0, DB1, UB2, UB3]
inference timesteps	50
τ	35

Table 9: 2048^2 SD 1.5 experiment settings.

A.3 SYNCHRONIZE STATISTICS BETWEEN TILES IN GROUPNORM

Params	Values
latent resolution	$4 \times 256 \times 256$
re-dilated blocks	[DB3, MB, UB0]
dilation scale rb.	[2, 2, 2]
dispersed blocks	\emptyset
progressive	✗
noise-damped cfg.	✗
inference timesteps	50
τ	30

Table 10: 2048² SD XL 1.0 settings.

Params	Values
latent resolution	$4 \times 320 \times 320$
re-dilated blocks	[DB1, DB2, DB3, MB, UB0, UB1, UB2]
dilation scale rb.	[2, 2, 2.5, 2.5, 2.5, 2, 2]
dispersed blocks	\emptyset
progressive	✗
noise-damped cfg.	✓
noise-damped blocks	[DB1, DB2, UB1, UB2]
inference timesteps	50
τ	30

Table 11: 2560² SD XL 1.0 experiment settings.

Params	Values
latent resolution	$4 \times 256 \times 512$
re-dilated blocks	[DB1, DB2, DB3, MB, UB0, UB1, UB2]
dilation scale rb.	[2, 2, 2, 2, 2, 2, 2]
dispersed blocks	\emptyset
progressive	✗
noise-damped cfg.	✓
noise-damped blocks	[DB1, DB2, UB1, UB2]
inference timesteps	50
τ	30

Table 12: 4096 \times 2048 SD XL 1.0 experiment settings.

Params	Values
latent resolution	$4 \times 512 \times 512$
re-dilated blocks	[DB2, UB1]
dilation scale rb.	[2, 2]
dispersed blocks	[DB3, MB, UB0]
dilation scale db.	[2, 2]
dispersed kernel size	$3 \times 3 \rightarrow 5 \times 5$
progressive	✓
noise-damped cfg.	✓
noise-damped blocks	[DB2, UB1]
inference timesteps	50
τ	35

Table 13: 4096² SD XL settings.

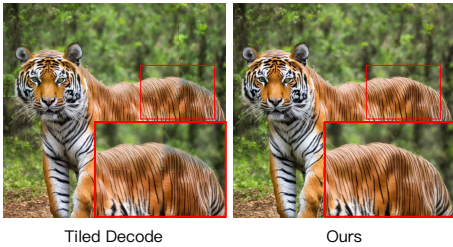

Figure 10: Direct tiled decode causes abrupt changes in tile borders and different color tones in tiles. We synchronize the statistics in VAE GroupNorm between tiles to address this problem.

When the generated image size is large (i.e., $> 2048 \times 2048$), the VAE of SD requires enormous VRAM for decoding and is usually not applicable on a personal GPU. A simple solution is decoding in tiles. However, tiled decoding usually causes abrupt changes between different tiles as shown in Fig. 10. To solve this, one can make overlapped regions between tiles and interpolate on the overlapped regions. However, another problem of tiled decoding is the inconsistent color tone between tiles. We figure out this is caused by the independent computation of GroupNorm (GN) layers in VAE between tiles. We propose to synchronize the feature statistics in GN in different tiles. Specifically, we compute the mean and std using all tiles instead of using only current ones. As shown in Fig. 10, it eliminates the color tone difference efficiently.

B RE-DILATED ATTENTION

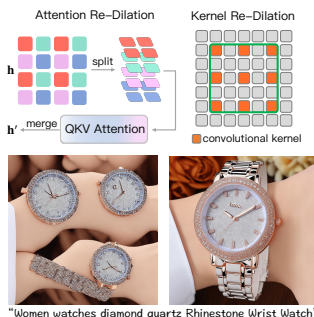

Figure 11: Illustration and results of two re-dilations.

Here, we introduce the experimented re-dilated attention. We aim to keep the original receptive field of attention, e.g., the attention token quantity. Thus, before calculating the attentional features, we first split the input feature map into four slices (the resolution is 4x higher than the training), and for each slice, we flat them into token sequences and feed them into the QKV attention. After the attention calculation, we merge them back to form the original feature arrangement. This operation strictly controls the token length of attention to be the same as training. However, this cannot solve the structure issue of the generated image, as shown in the 2nd row of Fig. 11. However, when applying the redilation on the convolutional kernel, the structure is totally correct. This demonstrates that the key cause of structure repetition lies in convolutional kernels.

C OTHER VISUALIZATIONS

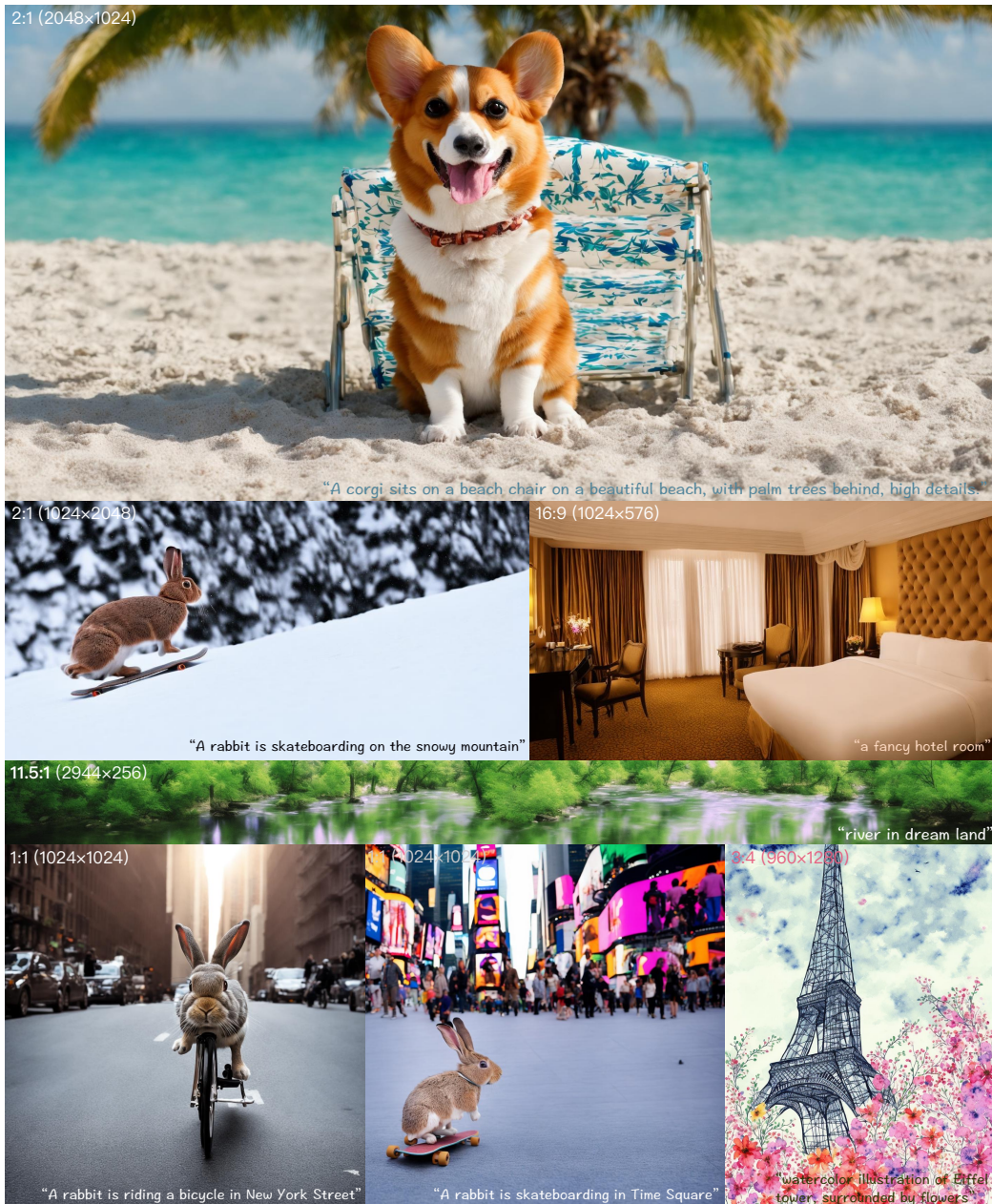

Figure 12: More generated results with our method and SD 2.1 with arbitrary aspect ratios and sizes.



Figure 13: More generated results with our method and SD 1.5 with arbitrary aspect ratios and sizes.



Figure 14: More generated results with our method and SD XL 1.0 with arbitrary aspect ratios and sizes.