

Focal Inferential Infusion Coupled with Tractable Density Discrimination for Implicit Hate Speech Detection

SARAH MASUD*, IIT Delhi, India

ASHUTOSH BAJPAI*, IIT Delhi; Wipro Research, India

TANMOY CHAKRABORTY, IIT Delhi, India

Although pre-trained large language models (PLMs) have achieved state-of-the-art on many NLP tasks, they lack understanding of subtle expressions of *implicit* hate speech. Such nuanced and implicit hate is often misclassified as non-hate. Various attempts have been made to enhance the detection of (implicit) hate content by augmenting external context or enforcing label separation via distance-based metrics. We combine these two approaches and introduce FiADD, a novel Focused Inferential Adaptive Density Discrimination framework. FiADD enhances the PLM finetuning pipeline by bringing the surface form of an implicit hate speech closer to its implied form while increasing the inter-cluster distance among various class labels. We test FiADD on three implicit hate datasets and observe significant improvement in the two-way and three-way hate classification tasks. We further experiment on the generalizability of FiADD on three other tasks, namely detecting sarcasm, irony, and stance, in which surface and implied forms differ, and observe similar performance improvement. We analyze the generated latent space to understand its evolution under FiADD, which corroborates the advantage of employing FiADD for implicit hate speech detection.¹

ACM Reference Format:

Sarah Masud, Ashutosh Bajpai, and Tanmoy Chakraborty. 2018. Focal Inferential Infusion Coupled with Tractable Density Discrimination for Implicit Hate Speech Detection. In . ACM, New York, NY, USA, 21 pages. <https://doi.org/XXXXXXXX.XXXXXXX>

1 INTRODUCTION

The advent of the Internet has led to a proliferation of hateful content [54]. However, what can be considered hate is subjective. According to the United Nations², hate speech is any form of discriminatory content that targets/stereotypes a group or an individual based on identity traits like race, gender, political ideology, etc. Data curators often employ lexicons and identity slurs to increase the coverage of hateful content at the cost of capturing lesser implied hatred [15, 50]. Of the myriad datasets on hate speech³ in English, only three [8, 18, 26] have labels for “implicit” hate.

Why is implicit hate hard to detect? Figure 1 shows two statements – “*Imp1: Black coffee should be banned in America.*” and “*Imp2: Ebola defines African Culture.*” Both Imp1 and Imp2 are statements that (i) do not contain any abusive or slur term, (ii) do not directly mention any target entity, and (iii) make indirect references to the target entity. These statements may not appear harmful for the uninitiated human or machine unless the implied context is provided, i.e., “*Black people are inferior.*” In light of this implied context, the non-hateful surface form now expresses explicit hate

*Both authors contributed equally to this research.

¹**Disclaimer:** The paper contains samples of hate speech, which are only included for contextual understanding. We tried our best to censor and not support these views.

²<https://www.un.org/en/hate-speech/understanding-hate-speech/what-is-hate-speech>

³<https://hatespeechdata.com/>

Permission to make digital or hard copies of all or part of this work for personal or classroom use is granted without fee provided that copies are not made or distributed for profit or commercial advantage and that copies bear this notice and the full citation on the first page. Copyrights for components of this work owned by others than ACM must be honored. Abstracting with credit is permitted. To copy otherwise, or republish, to post on servers or to redistribute to lists, requires prior specific permission and/or a fee. Request permissions from permissions@acm.org.

© 2018 Association for Computing Machinery.

Manuscript submitted to ACM

Fig. 1. Symbolic representation of Focused Inferential Adaptive Density Discrimination (FiADD) as applied to implicit hate speech detection. It combines three distance-metric objectives: (a) adaptive density discrimination to discriminate local clusters (this could be between non-hate and implicit hate, non-hate and explicit hate, or implicit hate and explicit hate), (b) focus on penalizing samples near the discriminant boundary (a.k.a non-uniform weightage to samples in the cluster), and (c) reduce the symbolic difference between the surface and semantic form of the textual content (the distance between implicit hate and implied hate).

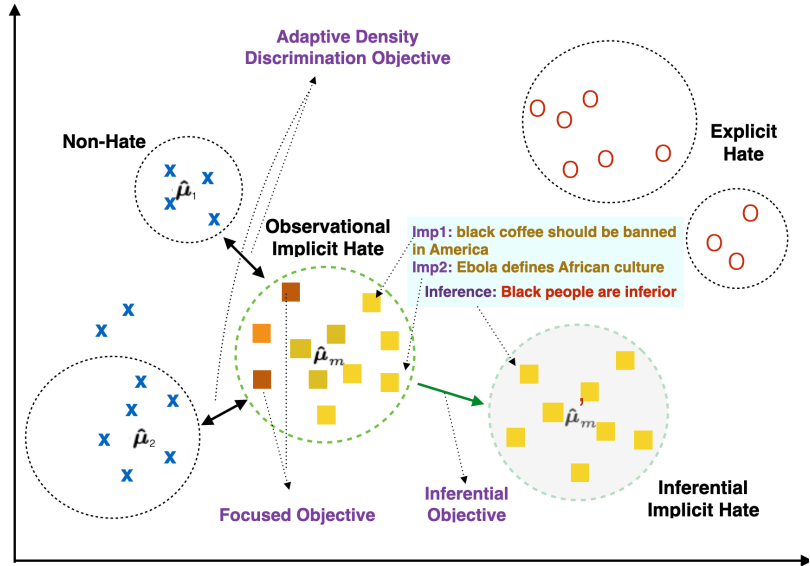

intended as “*Imp1: Black people should not be allowed in America*” and “*Imp2: Black culture is blighted.*” However, for a moderator (human or machine) to reach this inference, it must have a sufficient cultural context or implied knowledge.

Modeling implicit hate. Classifiers can work effectively with direct markers of hate [30]. Although non-contextually, depending on the presence/absence of hateful spans increases misclassification. One way to reduce misclassification is to strengthen the inter-cluster latent space via contrastive or exemplar sampling [27]. The other is to bring the surface meaning closer to its implied meaning, i.e., what is said vs. what is intended [18, 30]. However, contrastive loss operates in a per-sample setting [12], and providing additional information for implicit hate can sometimes increase noisy signals [30]. We, therefore, propose a framework for overcoming these drawbacks.

Proposed framework. To overcome the per-sample greedy approach, Adaptive Density Discrimination (ADD) [42] uses the local neighborhood to balance inter-class similarity and variation. For our use case, this can be employed to improve the local boundaries around implicit and non-hate samples that lie close. As discussed initially, by its nature, implicit hate speech hides behind its context, which, on the surface, appears non-hateful. We hypothesize that additional context provided by the implied explanation can unearth implicit hate [27]. We employ implied/descriptive phrases instead of knowledge tuples or Wikipedia summaries based on empirical findings [30] that the latter tend to be noisy if the tuples are not directly aligned with the entities in the statement. As we observe in Figure 1, this is hardly the case with implicit samples. Our intuition behind FiADD is that implied statements provide sufficient context, which, when combined with distance metric learning, should bring the surface form of implicit hate closer to its implied meaning, thus improving its detection.

We observe that FiADD variants improve overall (implicit) macro-F1 by 1.26% (2.41%), 1.02% (36.87%), and 0.53% (1.11%) on the LatentHate [18], ImpGab [26], and AbuseEval [8] datasets, respectively. We further hypothesize that our framework can generalize to other tasks where surface and implied meanings differ. In this regard, we observe an overall (minority implied class) macro-F1 improvement of 4.25% (23.96%), 2.37% (2.65%), and 3.09% (2.28%) in sarcasm [1], stance [36], and irony [56] detection, respectively. To establish that our results are not BERT [17] specific, we also experiment with HateBERT [7], XLM [10], and LSTM [24], and observe similar trends across setups.

Contributions. In short, we make the following contributions through this study:

- We establish the closeness of implicitly hateful samples from non-hateful ones. We then formulate a novel loss function and propose the FiADD framework to improve the classification of implicit hate (Section 4).
- We manually generate the implied explanations of 798 and 404 samples of implicit hate in AbuseEval and ImpGab, respectively (Section 3). These will serve as useful resources for future research.
- We experiment with multiple base architectures. Our analyses and ablations highlight how FiADD compares with the cross-entropy loss on three datasets. We also extend our analysis to three other tasks to show the generalizability of the model (Section 5 and 5.5).
- We perform error analysis and assess how the latent space evolves under FiADD (Sections 5.6 and 5.4).

Reproducibility. The source code and datasets will be public upon acceptance. A sample code and data are currently provided at <https://github.com/LCS2-IIIITD/FIADD>.

2 RELATED WORK

In this section, we focus on three aspects – (i) hate detection datasets, (ii) modeling of hate speech, and (iii) improvement of the classification task via distance-based metric.

Hate speech datasets in texts. Initially, Waseem and Hovy [62] released a dataset of 16k tweets labeled by experts. Meanwhile, Davidson et al. [15] released a dataset of 25k tweets marked by crowdsourced annotators. Along similar lines, we have hate and offense datasets from diverse online forums like Wikipedia [64], Stormfront [16], Facebook [46], Reddit [37] etc. On the other hand, to overcome the use of hate lexicons in curating the datasets, large-scale neutrally seeded datasets have also been proposed [19, 28, 55]. The initial research in hate speech datasets focused on multi-class text classification assuming English posts. However, to improve coverage, a broader of languages [59] and hate speech-related tasks are now being considered. Datasets in medium and low-resource languages like Arabic [4], German [5], Hindi [13], Indonesian [3], and Urdu [43] to name a few, are publicly available⁴. Meanwhile, tasks such as multi-label classification⁵ [25], hate speech diffusion [34, 45], rationale and span detection [35, 60], target group prediction [66] have been explored. However, most curated datasets are based on topics or keywords favoring explicit forms of hate [63]. In English, only three datasets have a fine-grained label for implicit hate – LatentHate [18] and AbuseEval [8] were curated from Twitter while ImpGab [26] was curated from Gab.

Modeling hate speech in NLP. The task of modeling hateful texts has led to an avalanche of hate detection systems [48, 59]. Initially, the systems employed tf-idf-based logistic regression [15, 62] and vanilla deep learning models [6, 20]. In light of explicit hate speech, the role of hate lexicons [41, 53] and ensemble models [2] has been explored. Following the trend of adopting pre-trained large language models (PLMs) for NLP [57], hate speech has seen a surge in PLM-based systems for hate detection [22, 40]. To better infuse the nature of hateful content and noisy texts on social media, PLMs like HateBERT [7] and BERTweet [38] have also been proposed for improving the performance of toxicity detection. With the recent trend of prompting generative large language models (LLMs), hate speech detection is now being evaluated under zero-shot [39, 40] and few-shot [11] settings. Despite the vast and apt interest in computational methods for hate speech detection, issues with generalizable [65] and biasing [21] are prevalent and active areas of research. Further sister tasks that employ LLMs for proactive mitigation [33], counter-speech generation [23, 44] and implicit explanation [47, 52] underpinned by hate speech detection have also been proposed.

⁴<https://hatespeechdata.com/>

⁵<https://www.kaggle.com/competitions/jigsaw-unintended-bias-in-toxicity-classification>

Table 1. Dataset employed in evaluating the FiADD framework. The statistics enlist the class-wise distributions for (a) Hate classification datasets and (b) SemEval datasets for generalizability testing.

(a)				(b)			
Datasets	Labels			Task	Labels		
AbuseEval	N-OFF	EXP	IMP	Sarcasm	N-SAR	SAR	
	11173	2129	798		3801	1067	
ImpGab	N-OFF	EXP	IMP	Irony	N-IRO	IRO	
	25102	2159	404		1890	1756	
LatentHate	N-OFF	EXP	IMP	Stance	NEU	ANG	FAV
	13291	1089	7100		918	1969	982

Especially within the area of unearthing the context of implicit hate speech, some studies explored leveraging external context in the form of either knowledge-graph tuples [18] or Wikipedia summaries [30]. Contradictory, both works observed that knowledge infusion at the input level lowered the performance on fine-grained implicit categories. We hypothesize that the external knowledge acts as a noisy signal without any context of what is implied. Meanwhile, datasets curated by Sap et al. [47] and Vidgen et al. [61] were also employed by Kim et al. [27] in their study for cross-dataset generalizability of hate. However, both datasets do not have a marker for implicit hate. Extending their analysis to our use case is only feasible with large-scale re-annotation.

Distance-metric learning. Cross-entropy loss (CE) is the most widely used loss function for classification tasks. However, it does not directly influence the clusters of positive and negative classes as it considers only one sample at a time. Hence, it impacts the inter/intra-class clusters sub-optimally [32]. As classification tasks can be modeled as obtaining distant clusters per class label, one can exploit clustering and distance-metric approaches to enhance the boundary among the class labels, leading to improved classification performance. Distance-metric learning-based methods largely employ either deep divergence via distribution [14] or point-wise norm [12]. The most popular deep metric learning is the contrastive loss family [9, 12, 49]. However, like cross-entropy, contrastive loss operates on a per-sample basis. Clustering-inspired methods [42, 51] have sought to overcome this issue by focusing on sub-clusters per class label. ADD *aka* Magnet loss [42] specifically lends a good starting point to operate the shift in the inter-cluster distance to extend to our use case as outlined in Figure 1.

3 DATASET

We focus on hate classification and SemEval⁶ datasets to evaluate the performance of the competing methods under various fine-tuning settings. Hate classification consists of three implicit hate datasets. Meanwhile, SemEval datasets of three tasks are employed to establish generalizability. In these tasks, the surface form of the text varies contextually from its semantic structure. Table 1 provides both sets’ label-wise distribution.

3.1 Hate Classification

We employ three hate datasets – LatentHate [18], AbuseEval [8], and ImpGab [26] with markings for implicit hate (i.e., have a label set as implicit, explicit, and non-hate). For LatentHate, we employ the first level of annotation, which has three classes (non-hate, explicit, and implicit), along with manual annotations of implied hatred for implicit samples.

⁶<https://semeval.github.io/>

Table 2. Some sample posts from AbuseEval and ImpGab along with their implied annotations. We also provide the cross-annotator scores and the cross-annotator remarks.

Dataset	Implicit Post	Implied Annotation	Score	Remarks
AbuseEval	@USER How dare you tell me what Antifa is doing is right. They are not fighting fascism. They are fighting for their own stupid cause. They are further from fixing fascism than the Republicans themselves	Anti-fascists are stupid and good for nothing.	5	Captured explicit target entity and the broader abuse in context
AbuseEval	@USER And this traitor thinks he is?	He thinks highly of himself.	2	Captured explicit target entity but fails to note broader abuse (traitor or anti-national) in context
ImpGab	I said it, and I stand by it! Blacks get almost all of their cultural cues and information from rap and sports. It's not like they're reading books or anything. URL	Black people don't read books. Black people are less intellectual	5	Target is identified correctly. An alternate implication can be: Black people are illiterate.
ImpGab	You missed out on his post saying there are still many Jews on #Gab! And didn't see his followers cuss out kike?! Good that you didn't see he claims himself a "racist capitalist"! I'm glad you missed ALL of them so you can continue to support him. AND excuse me, but he doesn't have much intelligence based on some of his posts. I'm not kike & not stand w/ any sides!	Christian are anti-Jews	3	Could be referring to a specific right-winged politician. Alternative meaning can be: You are as racist and anti-semitic as the leaders you follow.

Meanwhile, AbuseEval and ImpGab do not have implied counterparts. Hence, we manually annotate the implicit hate samples of these datasets with their implied meaning.

3.1.1 Annotation. For AbuseEval and ImpGab, two expert annotators (one male and one female; both of them are social media experts, and their ages range between 25 to 35) were employed to perform the annotations based on the following guidelines:

- Implied meaning should consider the post's author's perspective.
- Implied meaning should emphasize the post's content only.
- Annotations must be explicitly associated with the target entity.
- Annotations must contain a broader abusive context for the given post.
- Annotations should strive to balance lexical diversity and uniformity for a specific abuse on a particular target.

3.1.2 Annotation Agreement. The free text is hard to analyze for agreement scores. After performing annotations, the annotators performed cross-annotation agreement from a random sample of input and annotation pairs. The two annotators exchanged a random sample of 30 annotation pairs. They scored them on a scale of 5 points (1 lower agreement and 5 complete alignments in the annotation) Likert scale [29] to assess how closely the explained annotations match the implicit context. For AbuseEval, we obtain a mean agreement of 4.13 ± 1.13 out of 5 maximum, and 4.07 ± 1.41 for ImpGab. Table 2 lists some sample annotations and their agreement scores.

3.2 Generalizability Testing

We further consider three standard SemEval tasks for our generalizability analysis. We have binary labels for sarcasm [1] and irony [56] detection. Meanwhile, stance detection [36] is a three-way classification. While we have implied annotations for sarcasm, they are missing for the other two datasets. Here, no additional annotations are performed.

4 PROPOSED METHOD

We start with our motivation of employing distance-based metrics and then provide a primer ADD. Finally, we detail our formulation towards developing the novel Focused Inferential Adaptive Density Discrimination (FiADD) framework.

We begin with samples labeled for hate speech (implicit hate, explicit hate, or non-hate) and a set of implied statements for each implicit hate sample. Employing ADD objective, we look into a class's local groups, *aka* sub-clusters, by performing class-wise K-means clustering. Here, we also cluster the implied group. To reduce the distance between the implicit and implied clusters, FiADD measures the average distance of implicit points from implied meaning as a ratio of its distance to clusters of explicit and non-hate subspaces. A lower loss is obtained when the latter is high. Since not all local clusters (and not all samples within a group) contribute equally to the loss, our model penalizes the

Table 3. The inter-cluster distance between non-hate (N) and explicit hate (E), as well as non-hate and implicit hate (I) samples as measured by L1 average linkage distance (ALD) and L1 average centroid linkage distance (ACLD).

Dataset	ALD		ACLD	
	N-E	N-I	N-E	N-I
AbuseEval	132.73	128.81	96.69	94.94
ImpGab	132.32	131.62	97.62	97.08
LatentHate	125.12	122.59	90.86	90.69

samples closer to the class boundary. During the PLM finetuning, our proposed loss plugs into the cross-entropy loss and helps improve the detection of hate. An overview of FiADD’s architecture is shown in Figure 2.

4.1 Motivation

Hypothesis. We hypothesize that non-hate is closer to implicit hate than explicit hate. To establish the same, we measure the inter-cluster distance between non-hate and explicit hate and non-hate and implicit hate in the latent space using BERT. We record the pairwise average linkage distance (ALD) and average centroid linkage distance (ACLD). In pairwise average linkage distance, as the name suggests, the distance between two clusters is obtained as the average distance between all possible pairs (e_1, e_2) of samples where each element of the pair comes from a distinct group ($c(e_1) \neq c(e_2)$). Meanwhile, for the average centroid linkage distance, we first obtain the centroid of each cluster as a mean of all its representative samples and then compute the distance between the centers.

Observation. We note from Table 3 that: a) In the majority of instances (4 out of 6), non-hate is closer to implicit samples than to explicit. b) As expected, we also observe that ALD shows more variability than ACLD. It means while macroscopically/on the surface, implicit hate appears to be closer in syntax to non-hateful samples, at a microscopic level, there is higher variability among the explicit, implicit, and non-hateful samples. It follows from the fact that the mere presence of a keyword/lexicon does not render a sample as hateful. Stemming from these observations, we are motivated to explore distance-based metrics in addition to cross-entropy loss when performing implicit hate detection. We are inspired by the clustering method of ADD which optimizes the inter and intra-clustering around the local neighborhood. This directly maps to our problem of local variability (ALD) among the hateful and non-hateful samples. Further, the second observation motivates us to penalize and pay more attention to samples that contribute the most to misclassification loss. The intuition behind combining different distance-metric is outlined in Figure 1.

Notably, ADD already established its superiority compared to constrastive and triplet losses. Hence, we focus our experiments on combining ADD with cross-entropy and the utility of varying underlying PLMS instead.

4.2 Background

ADD clusters all the data points within a class into K representative local/sub-groups via K -means clustering. This within-label clustering helps capture the inter/intra-label similarity within the local neighborhood. ADD begins by randomly selecting a reference/seed cluster I_s^c representing class C and then picking M imposter clusters from neighborhood $I_{s_1}^{c'}, \dots, I_{s_m}^{c'}$ but from disparate classes ($c \neq c'$) based on their proximity to seed cluster. Intuitively speaking, consider the three-way hate speech classification task with implicit, explicit, and non-hate labels. Suppose implicit hate is chosen as the seed cluster. In this case, its imposter clusters will be from explicit hate or non-hate as these are two labels where implicit hate can be misclassified into, i.e., considered imposter. ADD then samples D points uniformly at random from each cluster. For the d^{th} instance, r_d is its latent vector representation, with $C(\cdot)$ representing the class label for the sample/representation under consideration. Subsequently, r_d^m is the representation for d^{th} sample in m^{th} cluster with $\mu(r)$ as its cluster center. μ_m^o captures the mean representation of m^{th} cluster. For each data point $d \in D$ in sample

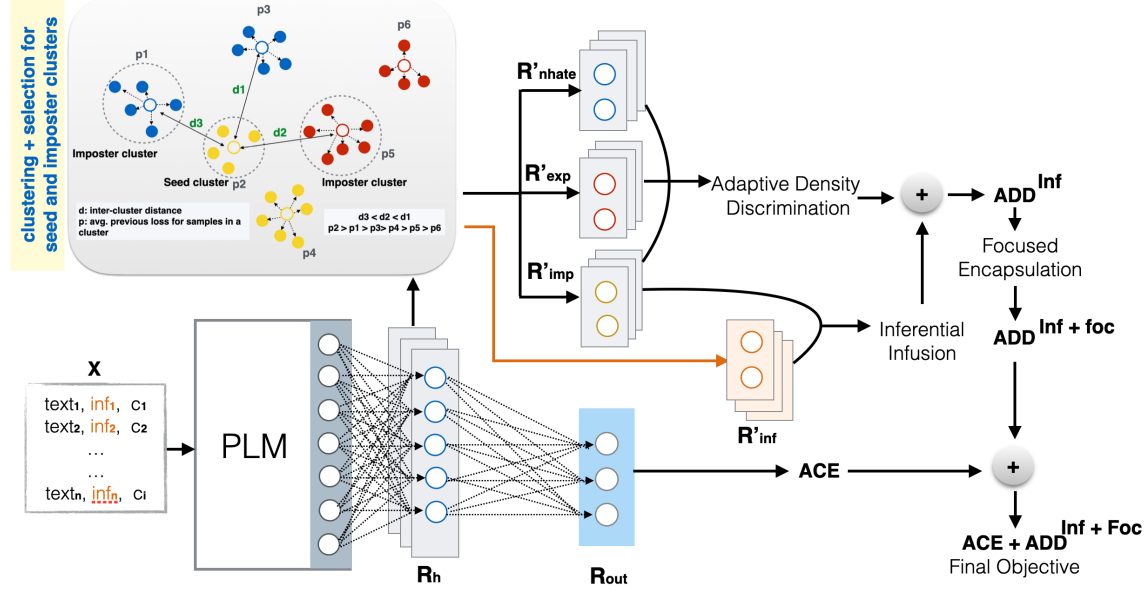

Fig. 2. Architecture for Focused Inferential Adaptive Density Discrimination (FiADD). X : a set of texts, implied annotations (only for implicit class), and class labels, PLM: pre-trained language model (frozen), R_h : hidden layer representation of 128 dimensions, R_{out} : output classification head (CH) with the size of output labels. [R'_{nhate} , R'_{exp} and R'_{imp}]: a subset of R_h representing selected (seed and imposter clusters) local densities of non-hate, explicit and implicit class, respectively. R'_{inf} : representation for respective inferential samples for selected implicit samples. ACE is the alpha cross-entropy (CE with class weights). ADD^{Inf} and $ADD^{Inf+foc}$ are the adaptive density discriminator with inferential only and inferential + focused objective, respectively.

cluster $m \in M$, ADD applies Eq. 1 such that it can discriminate the local distribution of classes (Eq. 2).

$$p^{ADD}(r_d^m) = \frac{e^{-\frac{1}{2\sigma^2} \|r_d^m - \mu_m^o\|_2^2 - \alpha}}{\sum_{\mu^o: C(\mu^o) \neq C(r_d^m)} e^{-\frac{1}{2\sigma^2} \|r_d^m - \mu^o\|_2^2}} \quad (1)$$

$$\ell(\Theta) = \frac{1}{MD} \sum_{m=1}^M \sum_{d=1}^D -\log p^{ADD}(r_d^m) \quad (2)$$

Here, α is a scalar representing the margin for the cluster separation gap, and σ^2 is the variance of all samples away from their respective centers. ADD approximates the overall variance in the dataset as $\sigma^2 = \frac{1}{MD-1} \sum_{m=1}^M \sum_{d=1}^D \|r_d^m - \mu_m^o\|_2^2$ and the mean of a cluster m as $\mu_m = \frac{1}{D} \sum_{d=1}^D r_d^m$.

4.3 Our Formulation

We hypothesize that ADD can help improve the discrimination around local clusters of implicit and non-hate samples that lie close. We begin by building a fine-tuned base model consisting of encoder-only PLMs followed by a projection layer R_h and a classification head (CH). We employ FiADD through the representations obtained from R_h . For each instance $(x_d, y_d) \in X$, we have x_d as the input post to be classified, and y_d is its label. We first obtain the representation of x_d from R_h , $r_d = R_h(x_p)$, where $x_p = PLM(x_d)$. Here $x_p \in \mathbb{R}^{768}$ and $r_d \in \mathbb{R}^{128}$. For each class label $y_d \in c_i$ ($c_i \in C$), we employ the respective embeddings r and offline K-means algorithm to obtain K clusters per class label. As the

current ADD setup fails to capture underlying implied meaning, we infuse this information into the latent space as an implied/inferential cluster. We map the implicit hate sample x_d to its implied counterpart \tilde{x}_d to bring the underlying not-so-subtle contempt closer to its one-to-one mapped implicit hatred via distance minimization between the center of their local densities. The latent representation of \tilde{x}_d is obtained via $\tilde{r}_d = R_h(\tilde{x}_d)$. The ADD setup remains the same as in Eq. 1 for explicit and non-hate. Meanwhile, we incorporate an additional similarity measure for implicit hate to bring it closer to its implied meaning. The updated Inferential Adaptive Density Discrimination (ADD^{inf}) with an additional component to reduce the distance between $(\tilde{r}_d, r_d) \forall d \in \{\text{implicit hate}\}$ is summarised in Eq. 3.

$$p^{ADD^{inf}}(r_d^m) = \left(e^{-\frac{1}{2\sigma^2} \|r_d^m - \mu_m^o\|_2^2 - \alpha} + e^{-\frac{1}{2\tilde{\sigma}^2} \|r_d^m - \mu_m^i\|_2^2 - \alpha} \right) \left/ \left(\sum_{\mu^o: C(\mu^o) \neq C(r_d^m)} -\frac{1}{2\sigma^2} \|r_d^m - \mu^o\|_2^2 \right) \right. \quad (3)$$

If r_1^m, \dots, r_d^m are representations for D samples of m^{th} cluster (implicit), then $\tilde{r}_1^m, \dots, \tilde{r}_d^m$ represent their respective inferential forms. Here, μ_m^o and μ_m^i are the mean representations of the implicit and inferential/implied form for m^{th} cluster, respectively. σ^2 and $\tilde{\sigma}^2$ are the approximations for the overall variance of observational representations from their respective inferential centers. It should be noted that selecting the seed cluster and its subsequent imposter clusters is a random process for initial iterations. We assign the label with the highest loss margin for later iterations as the seed.

Focal weight. So far, the formulation assigns uniform weights for all the samples. In contrast, some instances are closer to the boundary of the imposter clusters and hard to classify (i.e., contribute more to the loss). Inspired by the concept of focal cross-entropy [31], we improve the ADD^{inf} objective by introducing $ADD^{inf+foc}$. Under $ADD^{inf+foc}$, the loss of each sample in the local neighborhood is multiplied by a factor called focused term $(1 - p^{ADD^{inf}}(r_d^m))^\gamma$ in which γ , a hyperparameter, acts as a magnifier. The formulation assigns uniform weights as γ tends to zero, reducing to ADD^{inf} . In contrast, a higher value of γ penalizes the samples at the local boundary that are currently adjudged to neighboring clusters. Analogously, the focal term can be equated with paying ‘‘more attention’’ to specific data points in the context of the current set of neighbors under consideration [58].

We also propose a variant of the FiADD, with only focal encapsulation without inferential infusion. Our novel inclusion of focal ADD can thus be extended to other classification tasks. The overall focal update is enlisted in Eq. 4:

$$\ell^{ADD^*}(\Theta) = \frac{1}{MD} \sum_{m=1}^M \sum_{d=1}^D \left[- (1 - p^{ADD^*}(r_d^m))^\gamma \log(p^{ADD^*}(r_d^m)) \right] \quad (4)$$

Here ℓ^{ADD^*} captures the with and without inferential objective when $\ell^{ADD^{inf+foc}}$ and $\ell^{ADD^{foc}}$ respectively are employed. We utilise $p^{ADD^{inf}}$ for the former and p^{ADD} for the latter. This leads to the formulation of $ADD^{inf+foc}$ and ADD^{foc} variants of FiADD. While ADD^{foc} is a minor update on ADD, we empirically observe that focal infusion improves the ADD objective when tested on LSTMs (Section 5.5.1). Hence, the focal variants of FiADD are employed for our experiments with PLMs.

In a nutshell, for non-hate and explicit hate during training, the intra-cluster minimization is done according to the ADD function encapsulated under only a focused objective (Eq. 1 in Eq. 4). Consequently, for implicit hate during training, Eq. 3 can be broken into two parts that are summed. The first part is equivalent to the ADD function, thus focusing on reducing the intra-cluster minimization. In the second part, we want to bring it closer to the implied meaning cluster. This creates a tradeoff between keeping implicit clusters huddled together and moving implicit clusters near their implied meaning cluster. The overall combination of objectives is not contradictory but works in favor of implicit hate, as highlighted in the latent space analysis presented in Section 5.4. It is also important to point out that this discrimination and tradeoff are being carried out in the local neighborhood, which is aided by the focal loss (Eq. 4).

Table 4. Results for two-way classification task across all three hate-speech datasets using two pre-trained language models, BERT and HateBERT. N-Hate: non-hate and Hate: implicit + explicit hate. For each model under comparison, we report its best performance based on overall macro-F1 out of three random seeds (1, 4, 7). We also highlight the highest Hate class macro-F1 that the respective model can achieve out of the three seeds.

Dataset	Metric (F1)	BERT			HateBERT		
		ACE	ACE+ADD ^{foc}	ACE+ADD ^{inf+foc}	ACE	ACE+ADD ^{foc}	ACE+ADD ^{inf+foc}
LatentHate	Macro	0.6991	0.7049	0.7039	0.7121	0.7135	0.7121
	N-Hate	0.7599	0.7603	0.7638	0.7843	0.7787	0.7791
	Hate	0.6383	0.6495	0.6439	0.6400	0.6484	0.6450
	Highest Hate F1	0.6478	0.6491	0.6548	0.6615	0.6572	0.6630
ImpGab	Macro	0.6709	0.6886	0.6956	0.6889	0.7027	0.6987
	N-Hate	0.9171	0.9313	0.9355	0.9239	0.9398	0.9344
	Hate	0.4247	0.4459	0.4556	0.4538	0.4657	0.4631
	Highest Hate F1	0.4281	0.4494	0.4562	0.4538	0.4663	0.4631
AbuseEval	Macro	0.7075	0.7131	0.7124	0.7189	0.7176	0.7202
	N-Hate	0.8729	0.8779	0.8675	0.8767	0.8711	0.8808
	Hate	0.5420	0.5483	0.5574	0.5610	0.5641	0.5595
	Highest Hate F1	0.5502	0.5583	0.5625	0.5642	0.5710	0.5691

Overall loss. Apart from employing the embedding r_d in ADD^{inf} , it is passed through a classification head $y'_{ce} = CH(r_d)$ in parallel. We then combine cross entropy with the focal inference to obtain the final loss of FiADD (Eq. 5). Here β controls the contribution of the two losses.

$$L(\Theta) = \beta \ell^{CE}(\Theta) + (1 - \beta) \ell^{ADD^{inf+foc}}(\Theta) \quad (5)$$

Inference. During inference, like in the real world, the system does not have access to implied meaning. Once the PLM is trained via FiADD, the classification head performs classification during inference, similar to any PLM fine-tuned model. Here, we rely on the latent space being already modified so that the implicit statements are now closer to their semantic or implied form (Section 5.4).

5 EXPERIMENTAL RESULTS

In this section, we enlist the performance for classifying implicit hate and the model’s generalizability measured via macro-F1. Weighted cross-entropy (ACE) is used as a baseline across different experiments. To further corroborate the effectiveness of FiADD, an in-depth study of the latent space is carried out.

5.1 Experimental Setup

We run all experiments on two Nvidia V100 GPUs. Three random seeds (1, 4, 7) have been used across different experiments presented in this paper. The BERT model used in this paper is referred for ‘bert-base-uncased’, and XLM is referred for ‘xlm-roberta-large’ variants of these PLMs obtained from HuggingFace⁷. We follow an 80-20 split for the dataset across experiments (specific to random seed). This paper defines β value equal to 0.5, assigning equal weightage to cross entropy and the proposed framework. We consider $K = 3$ for all classification experiments. We also consider the number of imposter clusters $M = 2$ in all the experiments. We leave the experiments on β and the number of imposter clusters M for future work. We set 100 as the maximum K-means iterations in each training step. During fine-tuning, each training cycle is executed for a maximum of 5000 epochs.

⁷<https://huggingface.co/>

Table 5. Results for three-way classification tasks across all three hate-speech datasets using two pre-trained language models, BERT and HateBERT. N-Hate: non-hate, EXP: explicit hate, and IMP: implicit hate. For each model under comparison, we report its best performance based on overall macro-F1 out of three random seeds.

Dataset	Metric (F1)	BERT			HateBERT		
		ACE	ACE+ADD ^{loc}	ACE+ADD ^{inf+loc}	ACE	ACE+ADD ^{loc}	ACE+ADD ^{inf+loc}
LatentHate	Macro	0.5327	0.5331	0.5336	0.5537	0.5607	0.5571
	N-Hate	0.7722	0.7609	0.7474	0.7480	0.7654	0.7829
	EXP	0.2682	0.2775	0.2776	0.3403	0.3300	0.3111
	IMP	0.5577	0.5610	0.5759	0.5728	0.5866	0.5774
ImpGab	Macro	0.4621	0.4575	0.4668	0.4797	0.4772	0.4813
	N-Hate	0.9198	0.9197	0.9258	0.9230	0.9434	0.9339
	EXP	0.3775	0.3850	0.3819	0.4055	0.4076	0.4190
	IMP	0.0889	0.0678	0.0928	0.1105	0.0806	0.0909
AbuseEval	Macro	0.5300	0.5328	0.5398	0.5309	0.5311	0.5313
	N-Hate	0.8541	0.8370	0.8867	0.8532	0.8611	0.8606
	EXP	0.5027	0.5256	0.5234	0.5038	0.5138	0.5111
	IMP	0.2333	0.2359	0.2094	0.2357	0.2185	0.2222

5.2 Hate Classification

We evaluate FiADD on hate speech detection using the three implicit hate datasets – LatentHate, AbuseEval, and ImpGab. We experiment with two variants of PLM, namely BERT and HateBERT. While BERT [17] is known to perform well for downstream NLP tasks, HateBERT [7] is a domain-specific offensive content detection model. We compare the macro-F1 score for fine-tuning with only the ACE against FiADD variants, namely ADD^{loc} and $ADD^{inf+loc}$. We report the best of three random seeds used for experiments where the best seed for a system may vary.

While having two-way and three-way classifications, the proposed framework is applied to the last hidden layer, assuming three classes in the dataset. Under both two-way and three-way classification, FiADD variants improve macro-F1 of hate class across all datasets on both PLMs. However, as we observe from Table 4, except for maximizing hate macro-F1, the inferential objective does not significantly impact the final macro-F1 in the case of a two-way classification. It can be explained by the partially conflicting objectives between the final two-way and $ADD^{inf+loc}$:s three-way objective. As reported in Table 4, variants of FiADD outperform their peers by a significant margin in the range of 0.14%-2.45% in macro-F1. We additionally note that FiADD variants improves overall macro-F1 by 0.58% (\uparrow 0.83%), 2.47% (\uparrow 3.68%), and 0.56% (\uparrow 0.79%) in LatentHate, ImpGab, and AbuseEval, respectively using BERT. On the other hand, inferential infusion reasonably impacts the outcome of the three-way classification task (Table 5), outperforming its peers across all three datasets in the range of 0.09%-0.98% in macro-F1. Overall, in 3-way classification, $ADD^{inf+loc}$ provide an improvement of 0.09% (\uparrow 0.17%), 0.47% (\uparrow 1.02%), and 0.98% (\uparrow 1.85%) in macro-F1 for LatentHate, ImpGab, and AbuseEval, respectively, on BERT. *It is noteworthy that we observe that even higher levels of improvement for implicit hate class than overall.* Compared to ACE in two-way classification ADD^{loc} brings up the implicit hate performance by 1.12% (\uparrow 1.75%) in LatentHate. Meanwhile, $ADD^{inf+loc}$ brings up the implicit hate performance by 3.09% (\uparrow 7.28%) and 1.54% (\uparrow 2.84%) in ImpGab and AbuseEval respectively. Similarly, compared to ACE in three-way classification, ADD^{loc} helps AbuseEval with an improvement of 0.26% (\uparrow 1.11%) in implicit hate. Meanwhile, $ADD^{inf+loc}$ helps LatentHate and ImpGab with an improvement of 1.82% (\uparrow 3.26%) and 0.39% (\uparrow 4.39%), respectively, in implicit hate.

FiADD also improves domain-specific HateBERT’s performance across different settings. FiADD variants improve two-way classification by overall 0.14% (\uparrow 0.20%), 1.38% (\uparrow 2.00%) and 0.13% (\uparrow 0.18%) for LatentHate, ImpGab, and

Table 6. Results for two-way classification task across all three hate-speech datasets using two pre-trained language models, BERT and HateBERT. N-Hate: non-hate and Hate: implicit + explicit hate. Here, 1, 4, 7 refers to the seed values employed in this study. Highlighted with green color are the outcomes where one of the variants of FiADD outperforms baseline ACE.

Dataset	Seed	Metric (F1)	BERT			HateBERT		
			ACE	ACE+ADD ^{foc}	ACE+ADD ^{inf + foc}	ACE	ACE+ADD ^{foc}	ACE+ADD ^{inf + foc}
LatentHatred	1	Macro	0.69658	0.70291	0.69780	0.70843	0.69983	0.70143
		N-Hate	0.76353	0.76010	0.76069	0.77514	0.75034	0.76016
		Hate	0.62962	0.64571	0.63492	0.64171	0.64931	0.64271
	4	Macro	0.69388	0.68951	0.69611	0.70720	0.70423	0.70709
		N-Hate	0.75595	0.75246	0.77109	0.76370	0.75511	0.76389
		Hate	0.63182	0.62656	0.62113	0.65070	0.65335	0.65030
	7	Macro	0.69907	0.70490	0.70387	0.71212	0.71353	0.71205
		N-Hate	0.75987	0.76033	0.76384	0.78429	0.77868	0.77907
		Hate	0.63827	0.64946	0.64389	0.63995	0.64838	0.64502
GAB	1	Macro	0.67087	0.68862	0.69557	0.68886	0.69790	0.69872
		N-Hate	0.91708	0.93134	0.93551	0.92391	0.92951	0.93438
		Hate	0.42467	0.44590	0.45563	0.45380	0.46630	0.46307
	4	Macro	0.66411	0.67941	0.67591	0.68248	0.67406	0.68307
		N-Hate	0.91361	0.92403	0.91952	0.92069	0.91105	0.92318
		Hate	0.41461	0.43478	0.43231	0.44428	0.43708	0.44295
	7	Macro	0.66402	0.68237	0.68206	0.68720	0.70271	0.68962
		N-Hate	0.91019	0.92933	0.92782	0.92266	0.93976	0.93049
		Hate	0.41784	0.43541	0.43630	0.45175	0.46565	0.44874
AbuseEval	1	Macro	0.69253	0.70627	0.70502	0.70633	0.71030	0.70699
		N-Hate	0.85193	0.86709	0.87395	0.87774	0.87652	0.88362
		Hate	0.53313	0.54545	0.53609	0.53492	0.54409	0.53035
	4	Macro	0.70748	0.71313	0.71244	0.71885	0.71761	0.72018
		N-Hate	0.87293	0.87792	0.86754	0.87667	0.87112	0.88082
		Hate	0.54204	0.54833	0.55735	0.56103	0.56410	0.55953
	7	Macro	0.67794	0.68587	0.68944	0.69350	0.70146	0.69910
		N-Hate	0.85393	0.86020	0.85694	0.85240	0.85052	0.86129
		Hate	0.67794	0.68587	0.68944	0.69350	0.70146	0.69910

AbuseEval respectively. Similarly, FiADD variants improve three-way classification by overall 0.7% (\uparrow 1.26%), 0.16% (\uparrow 0.33%), 0.04% (\uparrow 0.08%) for LatentHate, ImpGAB, and AbuseEval respectively.

We further detail the classification results in two-way (Table 6) and three-way (Table 7) settings for all random seeds across datasets. We note that FiADD outperforms the baseline across random seeds and datasets, barring a couple of exceptions with domain-specific PLM.

5.3 Generalizability Test

We also explore the generalization capabilities of the proposed framework on other semantically similar tasks. The availability of implied annotations in the sarcasm dataset enables us to access FiADD’s $ADD^{inf+foc}$ variant. The unavailability of such annotations in the other two tasks limits our experiments with only ADD^{foc} variant.

We consider BERT and XLM [10] for this evaluation and report the best of three random seeds. Table 8 (a) and (b) present the results for sarcasm detection and the other two tasks (irony and stance detection), respectively. We observe reasonable improvements in macro-F1 (0.4%-2.4%) across all three tasks using both PLMs. In the case of sarcasm detection $ADD^{inf+foc}$ employing XLM leads to a boost of 2.37% (\uparrow 4.25)% for sarcasm detection. Similarly, in the case of irony detection, ADD^{inf} leads to a performance improvement of 2.13% (\uparrow 3.09%) in BERT and 1.03% (\uparrow 1.55%) in XLM. For stance detection, ADD^{inf} leads to a performance improvement of 0.41% (\uparrow 0.71%) in BERT and 1.32% (\uparrow 2.37%) in XLM. Further, for the minority class considering the best of the BERT and XLM, we observe FiADD variants report an improvement of 6.06% (\uparrow 23.96)%, 1.35% (\uparrow 2.65%) and 3.14% (\uparrow 5.42%) for the respective minority class in sarcasm, stance and irony detection. The outcomes strongly indicate towards FiADD’s generalization capability.

Table 7. Results for three-way classification tasks across all three hate-speech datasets using two pre-trained language models, BERT and HateBERT. N-Hate: non-hate, EXP: explicit hate, and IMP: implicit hate. Here, 1, 4, 7 refers to the seed values employed in this study. Highlighted with green color are the outcomes where one of the variants of FiADD outperforms baseline ACE.

Dataset	Seed	Metric (F1)	BERT			HateBERT			
			ACE	ACE+ADD ^{inf} foc	ACE+ADD ^{inf} +foc	ACE	ACE+ADD ^{inf} foc	ACE+ADD ^{inf} +foc	
LatentHatred	1	Macro	0.50683	0.51872	0.51727	0.53277	0.53023	0.52951	
		N-Hate	0.76214	0.76201	0.74872	0.76216	0.75547	0.76122	
		EXP	0.20159	0.25344	0.25296	0.25575	0.26912	0.26109	
	4	IMP	0.55678	0.54072	0.55013	0.58041	0.56609	0.56622	
		Macro	0.52340	0.52746	0.52819	0.55372	0.56065	0.54937	
		N-Hate	0.77192	0.75288	0.76089	0.74803	0.76535	0.75695	
	7	EXP	0.26631	0.25862	0.28870	0.34032	0.33000	0.32524	
		IMP	0.53196	0.57088	0.53499	0.57281	0.58660	0.56591	
		Macro	0.53267	0.53312	0.53361	0.54265	0.54197	0.55713	
	GAB	1	N-Hate	0.77215	0.76094	0.74736	0.76769	0.77002	0.78290
			EXP	0.26815	0.27748	0.27762	0.29891	0.28428	0.31111
			IMP	0.55772	0.56095	0.57587	0.56136	0.57162	0.57738
4		Macro	0.46284	0.45740	0.47635	0.47448	0.47417	0.47325	
		N-Hate	0.90876	0.91715	0.92309	0.92432	0.92950	0.91882	
		EXP	0.36140	0.38783	0.37983	0.39767	0.40897	0.40336	
7		IMP	0.11834	0.06722	0.12612	0.10144	0.08403	0.09756	
		Macro	0.45289	0.45772	0.43606	0.46788	0.47415	0.44959	
		N-Hate	0.92661	0.91054	0.91243	0.92351	0.92469	0.91982	
4		EXP	0.38078	0.36646	0.37195	0.38563	0.42696	0.40542	
		IMP	0.05128	0.09615	0.02380	0.09448	0.07079	0.02352	
		Macro	0.47048	0.45741	0.46351	0.47969	0.47721	0.48128	
7	N-Hate	0.92416	0.93149	0.93998	0.92302	0.94337	0.93388		
	EXP	0.39033	0.40073	0.38159	0.40554	0.40761	0.41904		
	IMP	0.09696	0.04000	0.06896	0.11049	0.08064	0.09090		
AbuseEval	1	Macro	0.51761	0.52082	0.52249	0.52462	0.52638	0.52559	
		N-Hate	0.84885	0.84862	0.849518	0.86772	0.87497	0.87748	
		EXP	0.49009	0.51483	0.51033	0.53555	0.52680	0.52727	
	4	IMP	0.21390	0.19900	0.20765	0.17058	0.17737	0.17204	
		Macro	0.53002	0.53283	0.53982	0.52609	0.52095	0.52764	
		N-Hate	0.85409	0.83699	0.88670	0.86536	0.86110	0.87867	
	7	EXP	0.50272	0.52564	0.52338	0.52133	0.50485	0.51759	
		IMP	0.23325	0.23587	0.20938	0.19158	0.19689	0.18666	
		Macro	0.51914	0.52951	0.52534	0.53091	0.53110	0.53129	
	4	N-Hate	0.84480	0.85799	0.85942	0.85322	0.86106	0.86060	
		EXP	0.50420	0.51487	0.51041	0.50383	0.51378	0.51106	
		IMP	0.20843	0.21568	0.20618	0.23569	0.21848	0.22222	

Table 8. Comparative performance for two-way classification (sarcasm detection and irony detection) and three-way classification (stance detection) tasks. For each model, we report its best performance based on overall macro-F1 out of three random seeds.

(a)					(b)				
Tasks	Model	Metric (F1)	Objective		Tasks	Model	Metric (F1)	Objective	
			ACE	ACE+ADD ^{inf} +foc				ACE	ACE+ADD ^{inf} +foc
Sarcasm	BERT	Macro	0.5651	0.5610	Stance	BERT	Macro	0.5735	0.5776
		N-SAR	0.8329	0.8501			NEU	0.5009	0.4910
		SAR	0.2974	0.2720			ANG	0.6964	0.7090
	XLM	Macro	0.5577	0.5814		FAV	0.5231	0.5327	
		N-SAR	0.8626	0.8493		Macro	0.5560	0.5692	
		SAR	0.2529	0.3135		NEU	0.4494	0.4637	
Irony	BERT	Macro	0.6886	0.7099	Irony	BERT	N-IRO	0.7379	0.7658
		N-IRO	0.7379	0.7658			IRO	0.6394	0.6540
		IRO	0.6394	0.6540			Macro	0.6637	0.6740
	XLM	Macro	0.6637	0.6740		XLM	N-IRO	0.7482	0.7372
		N-IRO	0.7482	0.7372			IRO	0.5792	0.6106
		IRO	0.5792	0.6106					

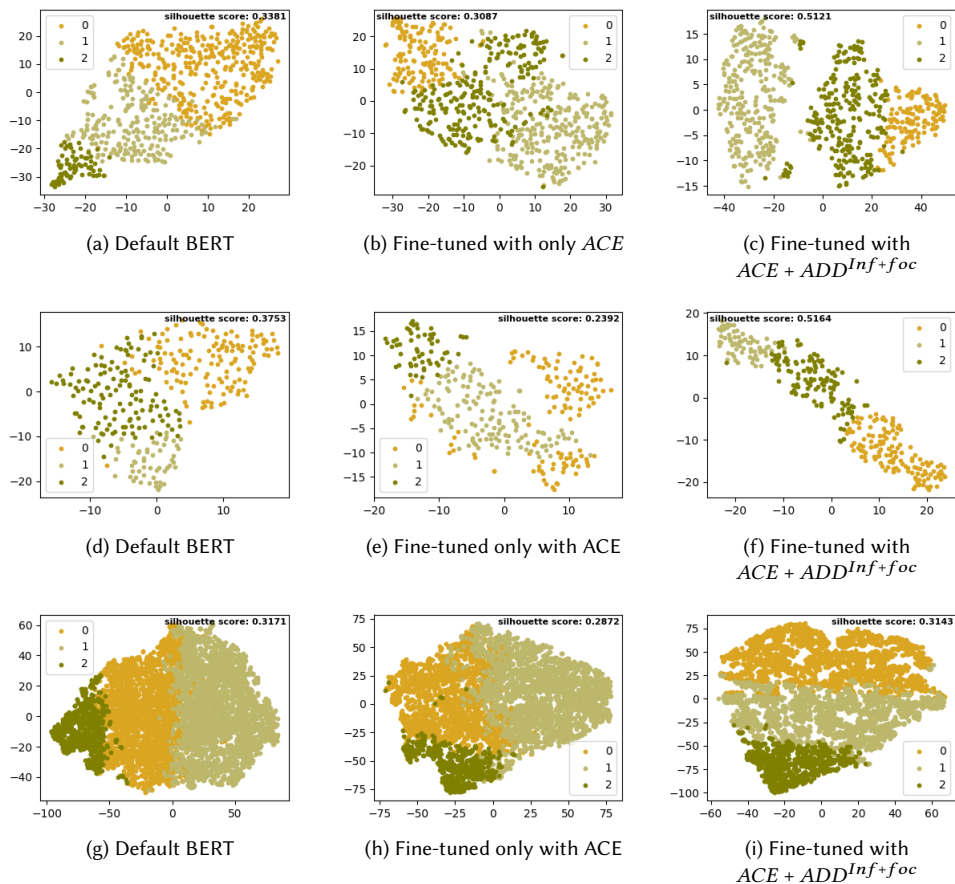

Fig. 3. 2D t-SNE plots of the last hidden representations after applying K-means ($K=3$) on the implicit class for the AbuseEval1 (a,b,c), ImpGab (d,e,f) and LatentHate (g,h,i) datasets. $\{0, 1, 2\}$ are the random cluster ids. 0.34, 0.31, and 0.51 are the silhouette scores for cases (a), (b), and (c), respectively, in AbuseEval1. 0.38, 0.24, and 0.52 are the silhouette scores for cases (d), (e), and (f), respectively, in ImpGab. 0.32, 0.29, and 0.32 are the silhouette scores for cases (d), (e), and (f), respectively, in LatentHate. In all cases, the higher the score, the better discriminated the clusters.

5.4 Latent Space Analysis

ADD^{foc} objective. Employing the ADD-based objective, we aim to differentiate local densities within a class by performing clustering. Silhouette score is one of the standard metrics used to quantify the separation between clusters, where a higher score represents clusters far from each other. Thus, after applying the ADD-based objective, we expect a higher silhouette score for a class's sub-clusters. Figure 3 shows the implicit embedding space of AbuseEval1, ImpGab and LatentHate after applying K-means on the default BERT embedding (a,d,g), BERT fine-tuned with the ACE (b,e,h), and FiADD (c,f,i) on three-way classification. The higher the silhouette score, the better discriminated the clusters. A 0.2, 0.28, and 0.03 points increase in the scores is observed when comparing FiADD with ACE for AbuseEval1, ImpGab, and LatentHate respectively. This increase in the silhouette score validates that the local densities within a class get further refined under $ADD^{inf+foc}$ objective. As expected, ACE treats the implicit class as a single homogeneous cluster.

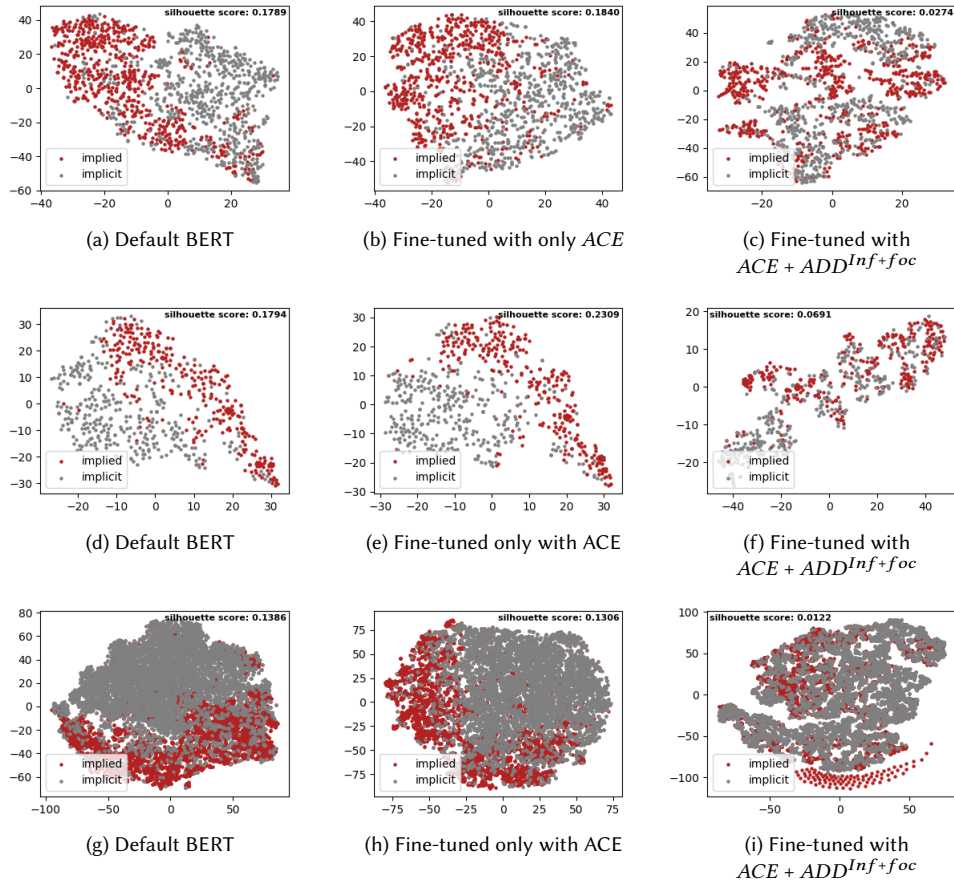

Fig. 4. 2D t-SNE plots of the last hidden representations obtained for the implicit class and its respective inferential (implied) set for the AbuseEval (a,b,c), ImpGab (d,e,f) and LatentHate (g,h,i) datasets. 0.18, 0.18, and 0.03 are the silhouette scores for cases (a), (b), and (c), respectively, in AbuseEval. 0.18, 0.23, and 0.07 are the silhouette scores for cases (d), (e), and (f), respectively, in ImpGab. 0.14, 0.13, and 0.01 are the silhouette scores for cases (g), (h), and (i), respectively, in LatentHate. In all cases, the lower the score, the better the system captures the closeness between the surface form and the implied form of hate.

Interestingly, in the case of LatentHate the silhouette score does not improve over the default BERT, even though it improves over ACE. Many local densities formed are clearly visible in 2D visualization; hence, a deeper analysis with multiple K values will be required to further establish the efficacy of the framework in this case.

Inferential infusion. The inferential objective ($ADD^{Inf+foC}$) brings implicit hate (surface-form) close to its inferential (semantic-form) meaning in embedding space. We again use the silhouette score here to quantify the same. Here, we expect a significant drop in silhouette scores between these clusters under FiADD. Figure 4 visualizes the embedding space of default BERT (a,d,g), BERT fine-tuned with the ACE (b,e,h), and FiADD (c,f,i) on three-way classification for AbuseEval, ImpGab, and LatentHate. A drop of 0.15, 0.16, and 0.12 in silhouette score is observed when comparing BERT+ACE with FiADD for AbuseEval, ImpGab, and LatentHate, respectively. It corroborates that the implicit and implied meaning representations are brought significantly closer to each other by employing the FiADD.

Table 9. Baseline improvements of ADD^{foc} over vanilla ADD for two-way hate speech classification. We report each model’s best performance based on overall macro-F1 out of three random seeds.

Dataset	Metric (F1)	LSTM		
		ADD	α -ADD	ADD^{foc}
LatentHatred	Macro	0.557	0.601	0.665
	N-Hate	0.646	0.695	0.782
	Hate	0.469	0.509	0.629
GAB	Macro	0.554	0.566	0.639
	N-Hate	0.919	0.911	0.927
	Hate	0.189	0.222	0.351
AbuseEval	Macro	0.552	0.554	0.634
	N-Hate	0.820	0.780	0.851
	Hate	0.284	0.327	0.417

5.5 Ablation Study

This section presents an in-depth analysis of the significance of ADD^{foc} over ADD along with the influence of hyperparameters like the number of clusters (k) and focal magnifier (γ).

5.5.1 ADD^{foc} Comparison with Vanilla ADD . In this experiment, we explore the improvement in performance of ADD^{foc} over vanilla ADD (Equation 4) without the combination with cross-entropy. We follow a similar prediction methodology as adopted by [42] in ADD ; a sample gets assigned the label based on the nearest cluster in latent space formed at the end of the training cycle. We avoid any PLMs and choose a simple LSTM [24] model to baseline the comparisons. We compared the basic ADD formulation with ADD with class weights (α - ADD) and ADD with focal encapsulation (ADD^{foc}) across all three hate speech datasets. We observe from Table 9 a significant performance improvement in the range of 8.2-10.8% in overall macro-F1 using ADD^{foc} across all three datasets. Especially for the minority class, we observe an even higher performance improvement in the range of 13.3-16.2% when comparing ADD^{foc} with its base version. We recommend using our ADD^{foc} variant instead of vanilla ADD for future work involving adaptive density discriminant learning. Interestingly, we note that α - ADD does not outperform ADD^{foc} . Rather, its performance lingers closer to vanilla ADD . Hence, it is not employed as a baseline in main experiments.

5.5.2 Significance of Hyper-parameters of the Proposed Framework. We further experiment with the hyper-parameters of the FiADD. The experiments are performed on a two-way hate classification task on the AbuseEval dataset using BERT as a pre-trained model. The limited range for the probe is heuristically defined based on the sample size of categories. We recommend defining the range of values on a case-to-case basis for optimized performance.

Figure 5(a) represents the significance of the number of clusters in the range of [2-4]. We observe the best value of the number of clusters for the AbuseEval dataset is 3. The significance of the γ coefficient used in the focused objective is presented in Figure 5(b). The probe is limited to [1-5] with a unit interval. We observe the best-performing outcome of focused objective at γ equals 2. The value incidentally aligns with the best value identified by Lin et al. [31]. All the experiments presented in this paper use these best values identified for hyper-parameters.

5.6 Error Analysis

We conduct an error analysis to determine the efficacy of FiADD. We consider a positive/negative case where the predicted label for an implicit sample is correctly/incorrectly classified. To explain these two scenarios, we estimate the relative distance of the implicit sample from explicit and non-hate clusters. The motivation for FiADD is that implicit is closer to non-hate than explicit. Employing FiADD should correct the misclassified implicit labels if this hypothesis

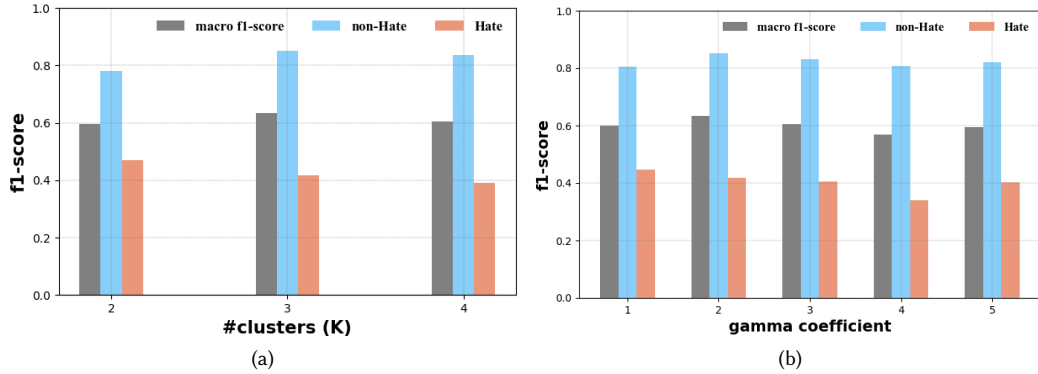

Fig. 5. The variation in performance with changing values of a) number of clusters (k) and b) focal parameter (γ). For both cases, we employ the AbuseEval on an LSTM base model the ADD^{foc} in the two-way classification task.

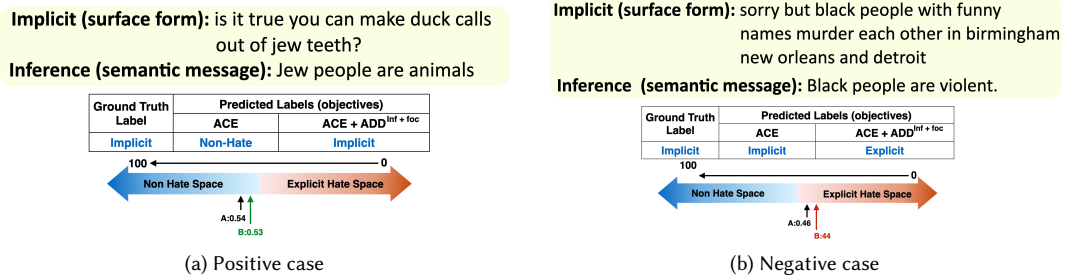

Fig. 6. Error analysis with (a) correctly and (b) incorrectly classified samples in three-way classification on LatentHate. Here [A, B] are the relative positions of implicit sample w.r.t non-hate and explicit space fine-tuned with ACE and $ADD^{inf+foc}$, respectively.

holds. On the other hand, a false-positive may occur if the example is already close to explicit subspace. Further, moving it toward explicit space can cause misclassification. To estimate the relative position of the implicit sample, we first perform K-means clustering on non-hate and explicit latent space to identify the center of local densities. We then calculate the average Manhattan distance between the implicit samples and these local density centers. Finally, we obtain the relative score from explicit space by normalizing the average explicit distance by the sum of average distances from non-hate and explicit spaces.

We highlight a positive and a negative case in Figures 6(a) and (b), respectively. In the positive case, the implicit sample is closer to non-hate space (Point A) under the ACE objective. However, after employing the FiADD, its relative position moves away from non-hate and closer to explicit (point B). In contrast, the hypothesis does not hold for a given negative case where the implicit sample is already close to explicit hate (point A). After applying the proposed framework, it moves towards the explicit cluster, leading to its misclassification. In the future, this problem can be resolved to some extent by introducing a margin or constraint term to keep intact the distance between implicit and explicit. We also like to point out that, by design, the objective helps improve the detection of hate in a two-way classification where implicit is less likely to be misclassified as non-hate (Table 4).

6 CONCLUSION

Equipped with anonymity and the network effect of reaching a wider audience to share one’s opinions has increased the volume and variety of hate speech on the Web. This has put a considerable burden on human content moderators, necessitating automated hate speech detection systems. As part of this study, and in support of hate speech literature in general, we do not recommend completely removing human moderators but instead employing machine learning-based systems to perform the first level of filtering. As machines suffer from understanding nuanced concepts, this paper aims to present **Focused Inferential Adaptive Density Discrimination**, a generalized framework for semantic classification tasks in which the surface form of the source text differs from their implied/inferential, such as implicit hate speech detection. To this end, FiADD achieves three primary objectives jointly – adaptive density discrimination, inferential infusion, and penalizing the sample near the classification boundary. The efficacy of the FiADD’s variants is analyzed over three implicit hate detection datasets (with two of them being manually annotated by us for inferential context), three implicit semantic tasks (sarcasm, irony, and stance detection), and three PLMs (BERT, HateBERT, and XLM). FiADD outperforms the baseline cross-entropy loss on the hate classification task across three implicit hate speech datasets. We also observe its generalization capabilities across three other similar semantic tasks. A closer look at the latent space highlights the impact that FiADD has on the implicit clusters in bringing them near their implied meaning. We conclude our study by performing an error analysis inspired by our inter-cluster distance evaluation that motivated the use of ADD in the first place.

Currently, the setup utilizes manual annotations of implicit meaning to be available for inferential clustering. In the future, we expect an infusion of generative models to help here. Another drawback of this framework is that it requires computationally expensive K-means clustering on each training step on the entire training dataset. One way is to consider representations only for the given batch, starting with stratified sampling so that the batch is representative of the overall dataset. We conjecture that recent advancements in hashing and dictionary techniques can improve computational efficiency. In the future, we aim to make the system more computationally efficient and extend its application to other tasks. It would be especially interesting to review how focal infusion impacts the classification tasks in computer vision in comparison to existing ADD setups.

7 ETHICAL CONCERNS

This work focused on textual features and did not incorporate any personally identifiable metadata. Additionally, no user-specific signals were included. Further, no new dataset was scraped. Instead, existing public datasets were further annotated for our use case. For annotations, the annotators were sensitized about the task at hand and given sufficient compensation for their expert involvement. The annotators worked on 250 samples per day over four days to avoid feeling fatigued. Further, the annotators had access to the web; while annotating, they referred to multiple news sources to understand the context. The dataset of inferential statements for AbuseEval and ImpGab will be available to researchers on request.

REFERENCES

- [1] Ibrahim Abu Farha, Silviu Vlad Oprea, Steven Wilson, and Walid Magdy. 2022. SemEval-2022 Task 6: iSarcasmEval, Intended Sarcasm Detection in English and Arabic. In *Proceedings of the 16th International Workshop on Semantic Evaluation (SemEval-2022)*. Association for Computational Linguistics, Seattle, United States, 802–814. <https://doi.org/10.18653/v1/2022.semeval-1.111>
- [2] Hind S. Alatawi, Areej M. Althohali, and Kawthar M. Moria. 2021. Detecting White Supremacist Hate Speech Using Domain Specific Word Embedding With Deep Learning and BERT. *IEEE Access* 9 (2021), 106363–106374. <https://doi.org/10.1109/ACCESS.2021.3100435>

- [3] Ika Alfina, Rio Mulia, Mohamad Ivan Fanany, and Yudo Ekanata. 2017. Hate speech detection in the Indonesian language: A dataset and preliminary study. In *2017 International Conference on Advanced Computer Science and Information Systems (ICACSIS)*. 233–238. <https://doi.org/10.1109/ICACSIS.2017.8355039>
- [4] Raghad Alshaalan and Hend Al-Khalifa. 2020. Hate Speech Detection in Saudi Twittersphere: A Deep Learning Approach. In *Proceedings of the Fifth Arabic Natural Language Processing Workshop*. Association for Computational Linguistics, Barcelona, Spain (Online), 12–23. <https://aclanthology.org/2020.wanlp-1.2>
- [5] Dennis Assenmacher, Marco Niemann, Kilian Müller, Moritz Seiler, Dennis Riehle, Heike Trautmann, and Heike Trautmann. 2021. RP-Mod & RP-Crowd: Moderator- and Crowd-Annotated German News Comment Datasets. In *Proceedings of the Neural Information Processing Systems Track on Datasets and Benchmarks*, J. Vanschoren and S. Yeung (Eds.), Vol. 1. Curran. https://datasets-benchmarks-proceedings.neurips.cc/paper_files/paper/2021/file/c9e1074f5b3f9fc8ea15d152add07294-Paper-round2.pdf
- [6] Pinkesh Badjatiya, Shashank Gupta, Manish Gupta, and Vasudeva Varma. 2017. Deep Learning for Hate Speech Detection in Tweets. In *WWW*. 759–760.
- [7] Tommaso Caselli, Valerio Basile, Jelena Mitrović, and Michael Granitzer. 2021. HateBERT: Retraining BERT for Abusive Language Detection in English. In *Proceedings of the 5th Workshop on Online Abuse and Harms (WOAH 2021)*. Association for Computational Linguistics, Online, 17–25. <https://doi.org/10.18653/v1/2021.woah-1.3>
- [8] Tommaso Caselli, Valerio Basile, Jelena Mitrović, Inga Kartoziya, and Michael Granitzer. 2020. I Feel Offended, Don't Be Abusive! Implicit/Explicit Messages in Offensive and Abusive Language. In *Proceedings of the Twelfth Language Resources and Evaluation Conference*. European Language Resources Association, Marseille, France, 6193–6202. <https://aclanthology.org/2020.lrec-1.760>
- [9] W. Chen, X. Chen, J. Zhang, and K. Huang. 2017. Beyond Triplet Loss: A Deep Quadruplet Network for Person Re-identification. In *2017 IEEE Conference on Computer Vision and Pattern Recognition (CVPR)*. IEEE Computer Society, Los Alamitos, CA, USA, 1320–1329. <https://doi.org/10.1109/CVPR.2017.145>
- [10] Zewen Chi, Shaohan Huang, Li Dong, Shuming Ma, Bo Zheng, Saksham Singhal, Payal Bajaj, Xia Song, Xian-Ling Mao, Heyan Huang, and Furu Wei. 2022. XLM-E: Cross-lingual Language Model Pre-training via ELECTRA. In *Proceedings of the 60th Annual Meeting of the Association for Computational Linguistics (Volume 1: Long Papers)*. Association for Computational Linguistics, Dublin, Ireland, 6170–6182. <https://doi.org/10.18653/v1/2022.acl-long.427>
- [11] Ke-Li Chiu, Annie Collins, and Rohan Alexander. 2022. Detecting Hate Speech with GPT-3. arXiv:2103.12407 [cs.CL]
- [12] S. Chopra, R. Hadsell, and Y. LeCun. 2005. Learning a similarity metric discriminatively, with application to face verification. In *2005 IEEE Computer Society Conference on Computer Vision and Pattern Recognition (CVPR'05)*, Vol. 1. 539–546 vol. 1. <https://doi.org/10.1109/CVPR.2005.202>
- [13] Shivang Chopra, Ramit Sawhney, Puneet Mathur, and Rajiv Ratn Shah. 2020. Hindi-English Hate Speech Detection: Author Profiling, Debiasing, and Practical Perspectives. *Proceedings of the AAAI Conference on Artificial Intelligence* 34, 01 (Apr. 2020), 386–393. <https://doi.org/10.1609/aaai.v34i01.5374>
- [14] Hatice Kubra Cilingir, Rachel Manzelli, and Brian Kulis. 2020. Deep Divergence Learning. In *Proceedings of the 37th International Conference on Machine Learning (Proceedings of Machine Learning Research, Vol. 119)*, Hal Daumé III and Aarti Singh (Eds.). PMLR, 2027–2037. <https://proceedings.mlr.press/v119/cilingir20a.html>
- [15] Thomas Davidson, Dana Warmusley, Michael Macy, and Ingmar Weber. 2017. Automated Hate Speech Detection and the Problem of Offensive Language. *Proceedings of the International AAAI Conference on Web and Social Media* 11, 1 (May 2017), 512–515. <https://ojs.aaai.org/index.php/ICWSM/article/view/14955>
- [16] Ona de Gibert, Naiara Perez, Aitor García-Pablos, and Montse Cuadros. 2018. Hate Speech Dataset from a White Supremacy Forum. In *Proceedings of the 2nd Workshop on Abusive Language Online (ALW2)*. Association for Computational Linguistics, Brussels, Belgium, 11–20. <https://doi.org/10.18653/v1/W18-5102>
- [17] Jacob Devlin, Ming-Wei Chang, Kenton Lee, and Kristina Toutanova. 2019. BERT: Pre-training of Deep Bidirectional Transformers for Language Understanding. In *Proceedings of the 2019 Conference of the North American Chapter of the Association for Computational Linguistics: Human Language Technologies, Volume 1 (Long and Short Papers)*. Association for Computational Linguistics, Minneapolis, Minnesota, 4171–4186. <https://doi.org/10.18653/v1/N19-1423>
- [18] Mai ElSherief, Caleb Ziems, David Muchlinski, Vaishnavi Anupindi, Jordyn Seybolt, Mumun De Choudhury, and Diyi Yang. 2021. Latent Hatred: A Benchmark for Understanding Implicit Hate Speech. In *EMNLP*.
- [19] Antigoni Founta, Constantinos Djouvas, Despoina Chatzakou, Ilias Leontiadis, Jeremy Blackburn, Gianluca Stringhini, Athena Vakali, Michael Sirivianos, and Nicolas Kourtellis. 2018. Large Scale Crowdsourcing and Characterization of Twitter Abusive Behavior. *Proceedings of the International AAAI Conference on Web and Social Media* 12, 1 (Jun. 2018). <https://ojs.aaai.org/index.php/ICWSM/article/view/14991>
- [20] Antigoni Maria Founta, Despoina Chatzakou, Nicolas Kourtellis, Jeremy Blackburn, Athena Vakali, and Ilias Leontiadis. 2019. A Unified Deep Learning Architecture for Abuse Detection. In *WebSci*. 105–114.
- [21] Tanmay Garg, Sarah Masud, Tharun Suresh, and Tanmoy Chakraborty. 2023. Handling Bias in Toxic Speech Detection: A Survey. *ACM Comput. Surv.* 55, 13s, Article 264 (jul 2023), 32 pages. <https://doi.org/10.1145/3580494>
- [22] Koyel Ghosh and Dr. Apurbalal Senapati. 2022. Hate speech detection: a comparison of mono and multilingual transformer model with cross-language evaluation. In *Proceedings of the 36th Pacific Asia Conference on Language, Information and Computation*. De La Salle University, Manila, Philippines, 853–865. <https://aclanthology.org/2022.paclic-1.94>

- [23] Rishabh Gupta, Shaily Desai, Manvi Goel, Anil Bandhakavi, Tanmoy Chakraborty, and Md. Shad Akhtar. 2023. Counterspeeches up my sleeve! Intent Distribution Learning and Persistent Fusion for Intent-Conditioned Counterspeech Generation. In *Proceedings of the 61st Annual Meeting of the Association for Computational Linguistics (Volume 1: Long Papers)*. Association for Computational Linguistics, Toronto, Canada, 5792–5809. <https://doi.org/10.18653/v1/2023.acl-long.318>
- [24] Sepp Hochreiter and Jürgen Schmidhuber. 1997. Long Short-Term Memory. *Neural Computation* 9, 8 (Nov. 1997), 1735–1780. <https://doi.org/10.1162/neco.1997.9.8.1735>
- [25] Muhammad Okky Ibrohim and Indra Budi. 2019. Multi-label Hate Speech and Abusive Language Detection in Indonesian Twitter. In *Proceedings of the Third Workshop on Abusive Language Online*. Association for Computational Linguistics, Florence, Italy, 46–57. <https://doi.org/10.18653/v1/W19-3506>
- [26] Brendan Kennedy, Mohammad Atari, Aida Davani, Leigh Yeh, Ali Omrani, Yehsong Kim, Kris Coombs, Gwenyth Portillo-Wightman, Shreya Havaladar, Elaine Gonzalez, Joseph Hoover, Aida Azatian, gabriel olmos, Alyzeh Hussain, Austin Lara, Adam Omary, Christina Park, Xin Wang, Clarisa Wijaya, Yong Zhang, Beth Meyerowitz, and Morteza Dehghani. 2022. The Gab Hate Corpus. (2022). <https://doi.org/10.17605/OSF.IO/EDUA3>
- [27] Youngwook Kim, Shinwoo Park, and Yo-Sub Han. 2022. Generalizable Implicit Hate Speech Detection Using Contrastive Learning. In *Proceedings of the 29th International Conference on Computational Linguistics*. International Committee on Computational Linguistics, Gyeongju, Republic of Korea, 6667–6679. <https://aclanthology.org/2022.coling-1.579>
- [28] Atharva Kulkarni, Sarah Masud, Vikram Goyal, and Tanmoy Chakraborty. 2023. Revisiting Hate Speech Benchmarks: From Data Curation to System Deployment. In *Proceedings of the 29th ACM SIGKDD Conference on Knowledge Discovery and Data Mining (Long Beach, CA, USA) (KDD '23)*. Association for Computing Machinery, New York, NY, USA, 4333–4345. <https://doi.org/10.1145/3580305.3599896>
- [29] R. Likert. 1932. A technique for the measurement of attitudes. *Archives of Psychology* 22 140 (1932), 55–55.
- [30] Jessica Lin. 2022. Leveraging World Knowledge in Implicit Hate Speech Detection. In *Proceedings of the Second Workshop on NLP for Positive Impact (NLP4PI)*. Association for Computational Linguistics, Abu Dhabi, United Arab Emirates (Hybrid), 31–39. <https://aclanthology.org/2022.nlp4pi-1.4>
- [31] Tsung-Yi Lin, Priya Goyal, Ross Girshick, Kaiming He, and Piotr Dollár. 2017. Focal Loss for Dense Object Detection. In *2017 IEEE International Conference on Computer Vision (ICCV)*. 2999–3007. <https://doi.org/10.1109/ICCV.2017.324>
- [32] Weiyang Liu, Yandong Wen, Zhiding Yu, and Meng Yang. 2016. Large-Margin Softmax Loss for Convolutional Neural Networks. In *Proceedings of The 33rd International Conference on Machine Learning (Proceedings of Machine Learning Research, Vol. 48)*, Maria Florina Balcan and Kilian Q. Weinberger (Eds.). PMLR, New York, New York, USA, 507–516. <https://proceedings.mlr.press/v48/liud16.html>
- [33] Sarah Masud, Manjot Bedi, Mohammad Aflah Khan, Md Shad Akhtar, and Tanmoy Chakraborty. 2022. Proactively Reducing the Hate Intensity of Online Posts via Hate Speech Normalization. In *Proceedings of the 28th ACM SIGKDD Conference on Knowledge Discovery and Data Mining (Washington DC, USA) (KDD '22)*. Association for Computing Machinery, New York, NY, USA, 3524–3534. <https://doi.org/10.1145/3534678.3539161>
- [34] Sarah Masud, Subhabrata Dutta, Sakshi Makkar, Chhavi Jain, Vikram Goyal, Amitava Das, and Tanmoy Chakraborty. 2021. Hate is the New Infodemic: A Topic-aware Modeling of Hate Speech Diffusion on Twitter. In *2021 IEEE 37th International Conference on Data Engineering (ICDE)*. 504–515. <https://doi.org/10.1109/ICDE51399.2021.00050>
- [35] Binny Mathew, Punyajoy Saha, Seid Muhie Yimam, Chris Biemann, Pawan Goyal, and Animesh Mukherjee. 2021. HateXplain: A Benchmark Dataset for Explainable Hate Speech Detection. In *Proceedings of the AAAI Conference on Artificial Intelligence*, Vol. 35. 14867–14875.
- [36] Saif Mohammad, Svetlana Kiritchenko, Parinaz Sobhani, Xiaodan Zhu, and Colin Cherry. 2016. SemEval-2016 Task 6: Detecting Stance in Tweets. In *Proceedings of the 10th International Workshop on Semantic Evaluation (SemEval-2016)*. Association for Computational Linguistics, San Diego, California, 31–41. <https://doi.org/10.18653/v1/S16-1003>
- [37] Ioannis Mollas, Zoe Chrysopoulou, Stamatis Karlos, and Grigorios Tsoumakas. 2022. ETHOS: a multi-label hate speech detection dataset. *Complex & Intelligent Systems* 8, 6 (01 Dec 2022), 4663–4678. <https://doi.org/10.1007/s40747-021-00608-2>
- [38] Dat Quoc Nguyen, Thanh Vu, and Anh Tuan Nguyen. 2020. BERTweet: A pre-trained language model for English Tweets. In *Proceedings of the 2020 Conference on Empirical Methods in Natural Language Processing: System Demonstrations*. Association for Computational Linguistics, Online, 9–14. <https://doi.org/10.18653/v1/2020.emnlp-demos.2>
- [39] Debora Nozza. 2021. Exposing the limits of Zero-shot Cross-lingual Hate Speech Detection. In *Proceedings of the 59th Annual Meeting of the Association for Computational Linguistics and the 11th International Joint Conference on Natural Language Processing (Volume 2: Short Papers)*. Association for Computational Linguistics, Online, 907–914. <https://doi.org/10.18653/v1/2021.acl-short.114>
- [40] Flor Miriam Plaza-del arco, Debora Nozza, and Dirk Hovy. 2023. Respectful or Toxic? Using Zero-Shot Learning with Language Models to Detect Hate Speech. In *The 7th Workshop on Online Abuse and Harms (WOAH)*. Association for Computational Linguistics, Toronto, Canada, 60–68. <https://doi.org/10.18653/v1/2023.woah-1.6>
- [41] Marco Polignano, Giuseppe Colavito, Cataldo Musto, Marco de Gemmis, and Giovanni Semeraro. 2022. Lexicon Enriched Hybrid Hate Speech Detection with Human-Centered Explanations. In *Adjunct Proceedings of the 30th ACM Conference on User Modeling, Adaptation and Personalization (Barcelona, Spain) (UMAP '22 Adjunct)*. Association for Computing Machinery, New York, NY, USA, 184–191. <https://doi.org/10.1145/3511047.3537688>
- [42] Oren Ripplé, Manohar Paluri, Piotr Dollár, and Lubomir D. Bourdev. 2016. Metric Learning with Adaptive Density Discrimination. In *4th International Conference on Learning Representations, ICLR 2016, San Juan, Puerto Rico, May 2-4, 2016, Conference Track Proceedings*, Yoshua Bengio and Yann LeCun (Eds.). <http://arxiv.org/abs/1511.05939>
- [43] Hammad Rizwan, Muhammad Haroon Shakeel, and Asim Karim. 2020. Hate-Speech and Offensive Language Detection in Roman Urdu. In *Proceedings of the 2020 Conference on Empirical Methods in Natural Language Processing (EMNLP)*. Association for Computational Linguistics, Online, 2512–2522. <https://doi.org/10.18653/v1/2020.emnlp-main.197>

- [44] Punyajoy Saha, Kanishk Singh, Adarsh Kumar, Binny Mathew, and Animesh Mukherjee. 2022. CounterGeDi: A Controllable Approach to Generate Polite, Detoxified and Emotional Counterspeech. In *Proceedings of the Thirty-First International Joint Conference on Artificial Intelligence, IJCAI-22*, Lud De Raedt (Ed.). International Joint Conferences on Artificial Intelligence Organization, 5157–5163. <https://doi.org/10.24963/ijcai.2022/716> AI for Good.
- [45] Dhruv Sahnun, Snehil Dahiya, Vasu Goel, Anil Bandhakavi, and Tannoy Chakraborty. 2021. Better Prevent than React: Deep Stratified Learning to Predict Hate Intensity of Twitter Reply Chains. In *2021 IEEE International Conference on Data Mining (ICDM)*. 549–558. <https://doi.org/10.1109/ICDM51629.2021.00066>
- [46] Joni Salminen, Hind Almerkehi, Milica Milenković, Soon-gyo Jung, Jisun An, Haewoon Kwak, and Bernard Jansen. 2018. Anatomy of Online Hate: Developing a Taxonomy and Machine Learning Models for Identifying and Classifying Hate in Online News Media. *Proceedings of the International AAAI Conference on Web and Social Media* 12, 1 (Jun. 2018). <https://doi.org/10.1609/icwsm.v12i1.15028>
- [47] Maarten Sap, Saadia Gabriel, Lianhui Qin, Dan Jurafsky, Noah A. Smith, and Yejin Choi. 2020. Social Bias Frames: Reasoning about Social and Power Implications of Language. In *Proceedings of the 58th Annual Meeting of the Association for Computational Linguistics*. Association for Computational Linguistics, Online, 5477–5490. <https://doi.org/10.18653/v1/2020.acl-main.486>
- [48] Anna Schmidt and Michael Wiegand. 2017. A Survey on Hate Speech Detection using Natural Language Processing. In *Proceedings of the Fifth International Workshop on Natural Language Processing for Social Media*. Association for Computational Linguistics, Valencia, Spain, 1–10. <https://doi.org/10.18653/v1/W17-1101>
- [49] Florian Schroff, Dmitry Kalenichenko, and James Philbin. 2015. FaceNet: A Unified Embedding for Face Recognition and Clustering. In *Proceedings of the IEEE Conference on Computer Vision and Pattern Recognition (CVPR)*.
- [50] Leandro Silva, Mainack Mondal, Denzil Correa, Fabricio Benevenuto, and Ingmar Weber. 2021. Analyzing the Targets of Hate in Online Social Media. *Proceedings of the International AAAI Conference on Web and Social Media* 10, 1 (Aug. 2021), 687–690. <https://ojs.aaai.org/index.php/ICWSM/article/view/14811>
- [51] Hyun Oh Song, Stefanie Jegelka, Vivek Rathod, and Kevin Murphy. 2017. Deep Metric Learning via Facility Location. In *2017 IEEE Conference on Computer Vision and Pattern Recognition (CVPR)*. 2206–2214. <https://doi.org/10.1109/CVPR.2017.237>
- [52] Rohit Sridhar and Diyi Yang. 2022. Explaining Toxic Text via Knowledge Enhanced Text Generation. In *Proceedings of the 2022 Conference of the North American Chapter of the Association for Computational Linguistics: Human Language Technologies*. Association for Computational Linguistics, Seattle, United States, 811–826. <https://doi.org/10.18653/v1/2022.naacl-main.59>
- [53] Vivian Stamou, Iakovi Alexiou, Antigone Klimi, Eleftheria Molou, Alexandra Saivanidou, and Stella Markantonatou. 2022. Cleansing & expanding the HURTLEX(el) with a multidimensional categorization of offensive words. In *Proceedings of the Sixth Workshop on Online Abuse and Harms (WOAH)*. Association for Computational Linguistics, Seattle, Washington (Hybrid), 102–108. <https://doi.org/10.18653/v1/2022.woah-1.10>
- [54] J. Suler. 2004. The Online Disinhibition Effect. *Cyberpsychology & behavior : the impact of the Internet, multimedia and virtual reality on behavior and society* 7 3 (2004), 321–326.
- [55] Cagri Toraman, Furkan Şahinuç, and Eyup Halit Yilmaz. 2022. Large-Scale Hate Speech Detection with Cross-Domain Transfer. In *Proceedings of the Language Resources and Evaluation Conference*. European Language Resources Association, Marseille, France, 2215–2225. <https://aclanthology.org/2022.lrec-1.238>
- [56] Cynthia Van Hee, Els Lefever, and Véronique Hoste. 2018. SemEval-2018 Task 3: Irony Detection in English Tweets. In *Proceedings of the 12th International Workshop on Semantic Evaluation*. Association for Computational Linguistics, New Orleans, Louisiana, 39–50. <https://doi.org/10.18653/v1/S18-1005>
- [57] Ashish Vaswani, Noam Shazeer, Niki Parmar, Jakob Uszkoreit, Llion Jones, Aidan N Gomez, Ł ukasz Kaiser, and Illia Polosukhin. 2017. Attention is All you Need. In *Advances in Neural Information Processing Systems*, I. Guyon, U. Von Luxburg, S. Bengio, H. Wallach, R. Fergus, S. Vishwanathan, and R. Garnett (Eds.), Vol. 30. Curran Associates, Inc. https://proceedings.neurips.cc/paper_files/paper/2017/file/3f5ee243547dee91fbd053c1c4a845aa-Paper.pdf
- [58] Petar Veličković, Guillem Cucurull, Arantxa Casanova, Adriana Romero, Pietro Liò, and Yoshua Bengio. 2017. Graph Attention Networks. *6th International Conference on Learning Representations* (2017).
- [59] Bertie Vidgen and Leon Derczynski. 2020. Directions in abusive language training data, a systematic review: Garbage in, garbage out. *PLOS ONE* 15, 12 (Dec. 2020), e0243300. <https://doi.org/10.1371/journal.pone.0243300>
- [60] Bertie Vidgen, Dong Nguyen, Helen Margetts, Patricia Rossini, and Rebekah Tromble. 2021. Introducing CAD: the Contextual Abuse Dataset. In *Proceedings of the 2021 Conference of the North American Chapter of the Association for Computational Linguistics: Human Language Technologies*. Association for Computational Linguistics, Online, 2289–2303. <https://doi.org/10.18653/v1/2021.naacl-main.182>
- [61] Bertie Vidgen, Tristan Thrush, Zeerak Waseem, and Douwe Kiela. 2021. Learning from the Worst: Dynamically Generated Datasets to Improve Online Hate Detection. In *Proceedings of the 59th Annual Meeting of the Association for Computational Linguistics and the 11th International Joint Conference on Natural Language Processing (Volume 1: Long Papers)*. Association for Computational Linguistics, Online, 1667–1682. <https://doi.org/10.18653/v1/2021.acl-long.132>
- [62] Zeerak Waseem and Dirk Hovy. 2016. Hateful Symbols or Hateful People? Predictive Features for Hate Speech Detection on Twitter. In *Proceedings of the NAACL Student Research Workshop*. Association for Computational Linguistics, San Diego, California, 88–93. <https://doi.org/10.18653/v1/N16-2013>
- [63] Michael Wiegand, Josef Ruppenhofer, and Elisabeth Eder. 2021. Implicitly Abusive Language – What does it actually look like and why are we not getting there?. In *Proceedings of the 2021 Conference of the North American Chapter of the Association for Computational Linguistics: Human Language*

- Technologies*. Association for Computational Linguistics, Online, 576–587. <https://doi.org/10.18653/v1/2021.naacl-main.48>
- [64] Ellery Wulczyn, Nithum Thain, and Lucas Dixon. 2017. Ex Machina: Personal Attacks Seen at Scale. In *Proceedings of the 26th International Conference on World Wide Web* (Perth, Australia) (*WWW '17*). International World Wide Web Conferences Steering Committee, Republic and Canton of Geneva, CHE, 1391–1399. <https://doi.org/10.1145/3038912.3052591>
- [65] Wenjie Yin and Arkaitz Zubiaga. 2021. Towards generalisable hate speech detection: a review on obstacles and solutions. *PeerJ Computer Science* 7 (June 2021), e598. <https://doi.org/10.7717/peerj-cs.598>
- [66] Michael Yoder, Lynnette Ng, David West Brown, and Kathleen Carley. 2022. How Hate Speech Varies by Target Identity: A Computational Analysis. In *Proceedings of the 26th Conference on Computational Natural Language Learning (CoNLL)*. Association for Computational Linguistics, Abu Dhabi, United Arab Emirates (Hybrid), 27–39. <https://doi.org/10.18653/v1/2022.conll-1.3>

Received 20 February 2007; revised 12 March 2009; accepted 5 June 2009