Masked Autoencoders are Efficient Continual Federated Learners

Subarnaduti Paul^{1,2*}, Lars-Joel Frey¹, Roshni Kamath^{1,2}, Kristian Kersting^{1,2,3,4}, Martin Mundt^{1,2*}

¹*Department of Computer Science, TU Darmstadt, Darmstadt, Germany*

²*Hessian Center for AI (hessian.AI), Darmstadt, Germany*

³*German Research Center for Artificial Intelligence (DFKI), Darmstadt, Germany*

⁴*Centre for Cognitive Science, TU Darmstadt, Darmstadt, Germany*

**{subarnaduti.paul, martin.mundt}@tu-darmstadt.de*

Abstract

Machine learning is typically framed from a perspective of i.i.d., and more importantly, isolated data. In parts, federated learning lifts this assumption, as it sets out to solve the real-world challenge of collaboratively learning a shared model from data distributed across clients. However, motivated primarily by privacy and computational constraints, the fact that data may change, distributions drift, or even tasks advance individually on clients, is seldom taken into account. The field of continual learning addresses this separate challenge and first steps have recently been taken to leverage synergies in distributed supervised settings, in which several clients learn to solve changing classification tasks over time without forgetting previously seen ones. Motivated by these prior works, we posit that such federated continual learning should be grounded in unsupervised learning of representations that are shared across clients; in the loose spirit of how humans can indirectly leverage others' experience without exposure to a specific task. For this purpose, we demonstrate that masked autoencoders for distribution estimation are particularly amenable to this setup. Specifically, their masking strategy can be seamlessly integrated with task attention mechanisms to enable selective knowledge transfer between clients. We empirically corroborate the latter statement through several continual federated scenarios on both image and binary datasets.

1 Introduction

Whether from a purely practical or from a biologically plausible perspective, building machines that mirror the capabilities of humans (Lake et al., 2017) requires the ability to continue learning throughout their lifetime (Chen & Liu, 2018). The key challenge is often framed as the sequential learning problem, where, much in contrast to traditional static train-validation-test dataset splits, neural models suffer from catastrophic interference (McCloskey & Cohen, 1989). They tend to forget what they have previously seen if revisits are disallowed. When surveying the literature landscape, several biological underpinnings (Kudithipudi et al., 2022) and practical pillars (Hadsell et al., 2020; Mundt et al., 2023) to alleviate the catastrophic forgetting phenomenon are typically at the focus of attention. Considerations span from regularization, dynamic architecture, and popular episodic memory buffer techniques (Hayes et al., 2021) to tangible quantities to measure compute, parameter growth, and various other performance assessments surrounding knowledge transfer and accumulation over time (Mundt et al., 2022a).

However, the primary objective of continual machine learning (CL) seems to be predominantly centered around maintaining a single model, heavily inspired by an individual human's ability to learn throughout their lifetime. At the same time, well-known research from social and cognitive sciences suggests that humans also heavily benefit not only from recalling their own experiences

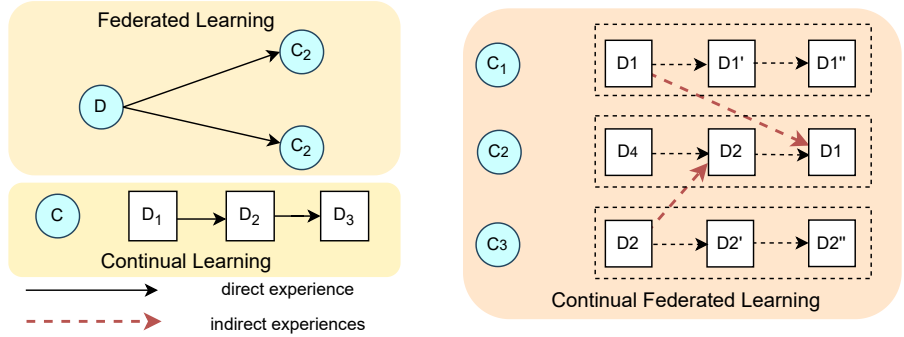

Figure 1: Set-up schematic. As data (on clients) may drift individually over time, models need to mitigate forgetting. In distributed scenarios, being additionally informed through indirect experience (dashed red arrows) provides further learning benefit, as similar data may appear on other clients at different points in time.

but also leveraging the knowledge of their fellow humans. In other words, they learn from indirect experiences. Take for instance an organization working together, where every member partially profits from the growing know-how simply by listening to the report of others (Argote & Miron-Spektor, 2011; Gino et al., 2010). In addition to each individual’s episodic memory, there thus exists the notion of a transactive memory (Wegner et al., 1985; Wegner, 1987). Relating back to machine learning, an intuitive parallel can be found in the concept of federated learning (FL) (McMahan et al., 2017; Kairouz et al., 2021), where several learning clients attempt to share and consolidate their knowledge, most commonly with a central server. Alas, FL comes with its own frequent focus, motivated primarily by computational efficiency and preservation of privacy by avoiding the explicit communication of data. As such, a recent survey (Criado et al., 2022) argues that FL has, quoting the original authors, a ”long road ahead“. The latter is attributed to the fact that while FL seems to distribute data and minimize communication, it seldom considers scenarios where data distributions on clients drift or individual tasks change over time. Speaking informally, although continual learning and federated learning share similar properties in data being distributed across ”time“ or ”space“ respectively, their joint consideration remains largely open. We point to figure 1 for visual intuition.

Thus, inspired by the notion of transactive memory and the necessity to combine federated and continual learning, we propose an unsupervised continual federated learner (CFL), focused on selectively sharing acquired representations. More specifically, we build on the previous work of federated weighted inter-client transfer (FedWeIT) (Yoon et al., 2021), which has proposed an attention based approach to CFL for supervised classification scenarios. In particular, we leverage their proposed parameter decomposition to intuitively integrate it with a masked autoencoder for distribution estimation (Germain et al., 2015). We demonstrate that MADE is a model that is particularly amenable to unsupervised CFL, due to its inherent masking strategy sharing a common denominator with attention based masking to avoid forgetting. In summary, our contributions are:

- We draw inspiration from the supervised FedWeIT and extend it to our unsupervised **Continual Federated M**asked autoencoders for **D**ensity **E**stimation (CONFEDMADE); an unsupervised continual federated learner based on masking to enable selective knowledge transfer between clients and reduce forgetting.
- We highlight that MADE is a model particularly amenable to CFL and investigate several non-trivial considerations, such as connectivity and masking strategy, beyond a trivial application of federated averaging and FedWeIT to the unsupervised setting.
- We extensively evaluate our approach on several CFL scenarios on both image and numerical data. Overall, CONFEDMADE consistently reduces forgetting while sparsifying parameters and reducing communication costs with respect to a naive unsupervised CFL approach.

2 Background and Related Work

We briefly introduce the key principles behind typical FL and CL set-ups, as well as their conjunction into CFL, illustrated in figure 1. In the process, we provide a concise overview of existing approaches, with a particular focus on an unsupervised perspective to motivate our proposed CONFEDMADE.

(Unsupervised) Federated Learning: A standard FL set-up collaboratively trains C number of clients $\{c_1, c_2, \dots, c_C\}$, typically aggregated through a server module to yield a global model (Kairouz et al., 2021). Here, each client learns on its privately accessible dataset, with the key objective that this data is to remain private and it is prohibited to share it explicitly. Instead, the pioneering and to date most popular approach is to communicate parameters or gradient signals and average them: so called federated averaging (FedAvg) (McMahan et al., 2017). In practice, the focus of FL seems to generally lie on preserving privacy while lowering communication and computation costs. Whereas data heterogeneity becomes a challenge, it is predominantly the case because a single task t comprised of dataset $D = \{\mathbf{x}_1, \mathbf{x}_2, \dots, \mathbf{x}_n\}$ is distributed across the C clients. As each client only sees a fraction N/C of the data, it can no longer be assumed that data is i.i.d. overall. Different FL algorithms have been proposed to deal with this challenge. For instance, FedProx (Li et al., 2020) introduces an additional proximity term to deal with deviations in data distribution across clients. FedBN (Li et al., 2021b) improves convergence speed by leveraging batch normalization layers, in a similar spirit to various works that have focused primarily on computational reduction (Li & Wang, 2019; Li et al., 2021b; Cheng et al., 2021). Analogously, select works (Singhal et al., 2021; Li et al., 2021a) aim to reduce computation and memory overhead, e.g. through reconstructing local parameters or formulating contrastive losses. Most of these approaches could intuitively find application in unsupervised approaches, where far fewer works have formulated explicitly tailored mechanisms. Here, dedicated techniques often frame the problem from a clustering perspective (Lubana et al., 2022; Lu et al., 2022; Chung et al., 2022; Zhang et al., 2020), reducing communication overheads in the process. Other works once more employ contrastive techniques to align representations through distillation (Han et al., 2022) or by fragmenting training into multiple stages (van Berlo et al., 2020). However, none of these works consider the case where each client’s data distribution may severely shift over time, or where client-specific tasks may change independently. In other words, although data heterogeneity is a prominent theme, continual learning seldom is.

(Unsupervised) Continual Learning: In continual learning, data heterogeneity is typically addressed from a different, complimentary perspective to the above FL set-up. A standard CL setup trains a single (client) model on a sequence of T tasks. This can be expressed through observing $\mathbf{x}_n^{(t)}$ of $N^{(t)}$ individual instances in dataset $D^{(t)}$, where generally $p(\mathbf{x}^{(t)}) \neq p(\mathbf{x}^{(t+1)})$. The earlier mentioned surveys in the introduction (Chen & Liu, 2018; Kudithipudi et al., 2022; Hadsell et al., 2020; Mundt et al., 2023) highlight how the focus is then typically on designing mechanisms to avoid forgetting in this single model, falling into general categories of regularization (e.g. elastic weight consolidation (Kirkpatrick et al., 2017), rehearsal (e.g. gradient episodic memory (Lopez-Paz & Ranzato, 2017)), or dynamic architectures (e.g. dynamically expandable architectures (Yoon et al., 2018)). Unsupervised continual learning approaches can correspondingly also be attributed to these pillars. Apart from works on lifelong generative adversarial networks (Goodfellow et al., 2014; Ramapuram et al., 2020), autoencoders (Ballard, 1987) trained with variational inference (Kingma & Welling, 2013) present a frequent choice. Both are popular due to their ability to rehearse previously observed examples through a generative model (Shin et al., 2017). Several unsupervised CL follow-ups (Achille et al., 2018; Rao et al., 2019; Mundt et al., 2022b) additionally propose how latent space structuring techniques aid in removing assumptions that have resulted in the majority of CL algorithms being tailored to incremental classifiers (Farquhar & Gal, 2018; Mundt et al., 2022a), shifting towards considerations on data distributions. However, unifying unsupervised CL with distributing data across multiple clients with changing tasks is yet to be considered by these works.

(Unsupervised) Continual Federated Learning: Formally, a continual federated learner will contain C clients $\{c_1, c_2, \dots, c_C\}$, where each client will individually observe a sequence of T_c tasks consisting of datasets $D_c^t = \{\mathbf{x}_1, \mathbf{x}_2, \dots, \mathbf{x}_n\}_c^t$. A single task for a single client at any time step t thus contains $N_c^{(t)}$ individual instances $\mathbf{x}_{c,n}^{(t)}$ that the local client trains for an overall amount of e epochs with r communication rounds to the outside. Following figure 1, a client could observe a task a different client has observed at a previous time step, i.e. observing instances originating from the same distribution a separate client has seen, or alternatively all data at all times can be distinct. Intuitively, one could attempt to apply any of the three pillars of CL to this distributed scenario, as algorithms such as FedAvg can directly be applied to any unsupervised learner. In fact, Park et al. (2021) follows this idea and couples training with a rehearsal strategy, whereas the supervised Usmanova et al. (2021) proposes the use of distillation. However, the latter is tailored to supervised scenarios and the former seems to be challenging to integrate into the typical federated learning desideratum of protecting privacy (by employing an explicit memory buffer). Similarly, we could

conjecture the use of the variational CL procedures outlined in the former subsection, but note that they do not easily allow for explicit data distribution estimates. Conceptually, our work thus follows a different approach, referred to as federated weighted inter-client transfer (FedWeIT) (Yoon et al., 2021). FedWeIT is a supervised framework that is cohesive with early postulated principles of modularity through reduction of parameter overlap (French, 1992). Specifically, it decomposes parameters into generic and task-specific ones and proceeds to learn attention maps to share and preserve appropriate subsets. In our work, we show that this prior art can be extended to the unsupervised scenario when integrated together with an efficient distribution estimator based on masked autoencoders (MADE) (Germain et al., 2015) and the effective FedAvg.

3 Unsupervised Continual Federated Learning with Masked Autoencoders

We now formally introduce our unsupervised CFL approach with the aim for a client to learn meaningful representations continually throughout their lifetime while leveraging other clients’ indirect experience. To mirror realistic real-world set-ups, the summarized CFL key elements are 1.) each client holds its sequence t of privately accessible task data; 2) the distribution of tasks across the clients may be different; 3) depicting a common continual learning assumption, a particular client is practically unaware of the ordering of the set of tasks and a particular set of data is only seen once in each client’s lifetime. Before introducing why masked auto-encoders are particular suitable to operate in CFL scenarios, we briefly introduce required preliminaries and analyze important considerations when first lifting masked autoencoders to a federated scenario (without the extra continual element).

3.1 Preliminaries: Federated Weighted Inter-client Transfer & Masked Autoencoding

FedWeIT (Yoon et al., 2021) has been proposed to tackle data heterogeneity in supervised continual federated classification. Here, with data distribution varied across clients, a traditional FedAvg (McMahan et al., 2017) will suffer from negative interference from other clients, typically leading to the global model averaging an improper solution. Unlike traditional CL strategies in earlier cited surveys, FedWeIT decomposes parameters and selectively transmits previously acquired knowledge across clients. A generic global parameter (W_c) is first decomposed into two sets of parameters: one assigned to capture generic knowledge for each client (B_c) and another assigned to capture task-specific knowledge (A_c) for each individual task per client. The Server in turn stores the task-adaptive parameters into a “knowledge base” (K_b) to combat catastrophic forgetting while learning the future task sequences. To selectively utilize the knowledge stored in K_b and reduce inter-client interference, each client learns to allocate a weighted attention α along with a threshold mask m_c :

$$W_c^t = B_c^t * m_c^t + A_c^t + \sum_{i \in C/c} \sum_{j < |t|} \alpha_{(i,j)}^t * A_i^{(j)} \quad (1)$$

In order to efficiently decompose and limit forgetting, two additional loss terms are then optimized:

$$\min_{B_c^{(t)}, A_c^{(1:t)}, \alpha_c^{(t)}, m_c^{(t)}} L(W_c^t, T_c^{(t)}) + \lambda_1 \Omega(\{m_c^{(t)}, A_c^{(1:t)}\}) + \lambda_2 \sum_{i=1}^{t-1} \|\Delta B_c^{(t)} \odot m_c^{(i)} + \Delta A_c^{(i)}\|_2^2 \quad (2)$$

Here, in the first term Ω denotes a sparsity-inducing regularizer, whereas the second regularizer term is used to reduce catastrophic forgetting with respect to prior time steps by limiting the change in relevant parameters. λ_1 and λ_2 are hyperparameters to weigh the individual terms.

Masked Autoencoders Germain et al. (2015) have been originally proposed for the purpose of distribution estimation (MADE). We will later highlight why they are particularly suitable for CFL beyond their demonstrated capability for unsupervised learning, after delving into some important considerations and caveats. In particular, MADE adheres to the autoregressive property through the use of masking, where an output unit \hat{x}_d only depends on previous input units $x_{<d}$, assuming a d -dimensional input. Hence, the autoencoder outputs take the form $\hat{x}_d = p(x_d | x_{<d})$, where $p(x_d)$ is the probability of observing x_d at d^{th} dimension, acting both as a data distribution estimator as well as a synthetic data generator. The respective structure of MADE with hidden layers l is given as:

Table 1: Practical considerations for federated MADE in terms of obtained negative log-likelihood (\downarrow is better).

(a) MADE with synchronized & distinct masks for federated MNIST. In the former, random masks (or the respective seed) gets communicated to all clients from the server, in the latter masks are drawn independently.

Clients	Synchronized Mask	Distinct Mask
1	75.23 \pm 0.27	75.23 \pm 0.27
2	76.93 \pm 0.35	97.27 \pm 0.21
5	83.51 \pm 0.83	170.7 \pm 0.66
10	86.23 \pm 0.99	219.1 \pm 1.54
20	87.89 \pm 1.11	264.0 \pm 3.57
40	89.89 \pm 1.47	301.2 \pm 2.15

(b) Federated MADE performance for architectural choices, including direct connections, connectivity- and order-agnostic training, as well as their combinations.

MADE configuration	Client	Server
Baseline	89.66 \pm 0.61	100.8 \pm 0.66
+Direct Connection	75.66 \pm 0.57	84.10 \pm 0.59
+Connectivity Agnostic	98.32 \pm 0.22	110.7 \pm 0.60
+Order Agnostic	81.18 \pm 0.64	84.78 \pm 2.37
+Direct+Order	62.83 \pm 0.30	71.42 \pm 1.19
+Direct+Connectivity	78.64 \pm 1.74	87.12 \pm 1.76
+DC+CA+OA	103.6 \pm 0.26	111.5 \pm 0.97

$$\begin{aligned}
 h^l(x) &= g(b^l + (W^l \odot M^{W^l})h^{l-1}(x)) \\
 \hat{x} &= \text{sigm}(c + (V \odot M^V)h^L(x) + (D \odot M^D)x)
 \end{aligned}
 \tag{3}$$

Here, \hat{x} is the reconstructed output for a given data input x . W, V, D denote the connection matrices for input to hidden layer, hidden to output layer, and a direct (skip) connection (DC) between the input and output layer respectively. The respective binary mask matrices M^W, M^V for hidden layer, and output layer connections are defined as:

$$M_{k,d}^W = 1_{m(k) \geq d} = \begin{cases} 1 & \text{if } m(k) \geq d \\ 0 & \text{otherwise,} \end{cases} \quad M_{k,d}^V = 1_{d > m(k)} = \begin{cases} 1 & \text{if } d > m(k) \\ 0 & \text{otherwise,} \end{cases}
 \tag{4}$$

where $k \in \{1..K\}$ refers to hidden layer units. Following equation 4, MADE assigns binary masks as we determine $m(k)$ for the k -th unit by sampling random integers less than D to the hidden units. Instead of learning a single deterministic model, we can further opt for **order-agnostic training** (OA) (resampling input ordering after each mini-batch, thereby reproducing the mask for the first hidden layer) or **connectivity-agnostic training** (CA) (resampling the hidden layers units). We point to the left side of figure 2 for an illustration of a MADE network and proceed to exploit the masking in MADE as a part of our CFL framework, thereby significantly reducing communication costs.

3.2 Embedding a Masked Autoencoder into the Federated-Averaging Framework

Before establishing MADE as an efficient continual federated learner, we first analyze traditional FL. Hence, we first take a step back from CL and distribute data from the same distribution across multiple clients and perform FedAvg through a central server. For each client, we define a MADE model based on the principles discussed in the previous section. In particular, we wish to investigate how a federated MADE (FEDMADE) performs when i) an increasing amount of clients get a smaller percentage of data, ii) we consider different training choices such as OA, CA, etc, iii) FEDMADE is confronted with only a (skewed) subset of data, to anticipate the later continual learning set-ups iv) and most importantly, whether and how the masking in different clients may interfere with each other.

To analyze and answer these questions, we report the performance in terms of obtained negative log-likelihoods, where smaller numbers are better, for an unsupervised federated MNIST (Deng, 2012) set-up. Each of the C clients receives $1/C^{th}$ of the data. In table 1a, we answer the above questions i) and iv) simultaneously and highlight the most important aspect of moving MADE into a federated scenario. Namely, we observe that sampling random integers for the masks, as suggested in the original MADE framework, independently on each client network, is detrimental to the obtained performance. The rationale is quite intuitive, as MNIST data gets distributed across an increasing amount of clients, at each step of federated communication and averaging different MADE clients presently update different sub-models. As a crucial step to enable effective FEDMADE and thus also later continual FEDMADE, we are required to communicate the (sequence of) mask(s) from the server as well. Although masks are small, this in fact incurs an extra communication expense, which can however be almost fully alleviated if we know that the different clients operate on similar

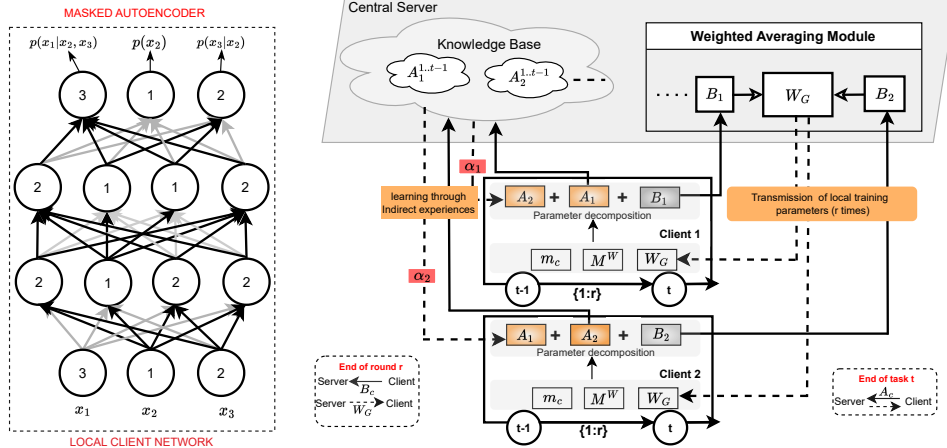

Figure 2: Proposed CONFEDMADE framework. MADE clients (left) send highly sparsified decomposed parameters following a masked subset and a server redistributes averaged global base parameters and stores task-adaptive parameters in a knowledge base. Clients selectively leverage the latter through attention masks.

devices and operating systems that can interpret the same random seed in the same manner, in which case communicating the latter is sufficient. The respective synchronized mask column in table 1a demonstrates how this almost fully alleviates performance drops, even with a large number of clients.

Table 1b complements this insight with answers to the remaining two questions, how different MADE choices affect performance, and how a skewed subset of data affects learned representations. For this purpose, we emulate the first step of a CL scenario and train a federated MADE on distributed MNIST with three classes. We can observe how this results in a perhaps expected loss in performance of the baseline without any of the optional MADE components. Naively, one would however equip MADE with all components that have initially been hypothesized to yield advantages in its original paper. Here, we observe a pattern that is consistent with our previous observation on masking. In fact, direct connections provide a cohesive benefit, but this is not necessarily the case for order and connectivity-agnostic training. The former’s resampled input ordering after each mini-batch independently on clients, as posited in the original work, leads to more robust models. The latter’s resampling on the level of hidden units however massively degrades performance due to interference with FedAvg, following the same intuition as with the earlier independent masking. As these considerations are imperative, we take them into account in our ensuing design of continual federated MADE.

3.3 CONFEDMADE: Learning Representations Continually through Indirect Experience

In the previous section, we laid out the foundation to employ MADE in federated scenarios. A critical next step is to inherit a form of continual learning strategy that can handle catastrophic forgetting under data distribution shifts. The most direct way would be to fully embed MADE into the earlier outlined FedWeIT framework. We will refer to this strategy as FedWeIT-MADE. However, we can move beyond such a combination. To this end, we propose CONFEDMADE, which on the one hand includes our earlier findings on federated MADE and on the other hand, incorporates its masking strategy based on the auto-regressive property in a more meaningful way into continual learning. This will outperform the naive combination while simultaneously cutting down communication costs.

Figure 2 provides a detailed overview of CONFEDMADE. First, note that the server serves a dual purpose: 1) averaging the learned representations by the clients and communicating global weights W_G back along with the masking matrices; 2) building a memory buffer as knowledge base for storing the task-specific representations learned by all the clients in previous time steps.

Second, we decompose the parameters of the clients’ MADE models, fusing earlier equations 3 and 1. Importantly, to further guarantee that the auto-regressive property is satisfied, we apply MADE’s masking to the additively decomposed parameters at any step:

$$W_C \odot M^W = B_c \odot m_c \odot M^W + A_c \odot M^W + \sum_{i \in C/c} \sum_{j < |t|} \alpha_{(i,j)} * A_i^{(j)} \odot M^W \quad (5)$$

Following our prior analysis, we strictly ensure that an identical auto-regressive masking strategy is imposed on each client network. Finally, the straightforward FedWeIT MADE strategy results in two masks for B_c , that despite masking the same set of parameters, would be treated independently. We could then treat MADE as the client architecture choice and optimize earlier equation 2.

However, once more, this is not only practically wasteful by not exploiting synergies, but can also hurt performance through interference effects when employing FedWeIT’s regularizers to pull towards a set of parameters that could presently be masked differently by the autoencoder. To both combat this interference of two independent masks (to clarify, for task adaptive parameters and for MADE) and make use of the sparsity induced by the MADE mask at any point in time, we thus optimize the decomposed MADE client parameters through a modified loss function:

$$\min_{B,A,\alpha,m} \mathcal{L}(W_{dec}^t, T_c^{(t)}) + \lambda_1(\Omega(\{m_c^{(t)}, A_c^{(1:t)} \odot M^W\})) + \lambda_2 \sum_{i=1}^{t-1} \|\Delta B_c^{(t)} \odot m_c^{(i)} + \Delta A_c^{(i)}\|_2^2 \quad (6)$$

We have primarily modified the sparsity-inducing term Ω , which in practice is an L1 norm (Yoon et al., 2021), to yield as small as possible amount of task-adaptive (A_c) parameters to populate the knowledge base. Here, at any point in time, we include a client’s present MADE mask M^W in n element-wise product with the A_c parameters. In this way, we avoid regularizing parameters that are currently not contributing to the MADE prediction and thus also explicitly further encourage task-adaptive parameters to be even sparser, subject to the empirically chosen masking ratio of the MADE architecture. We analyse this trade-off in the later experimental section. The second, perhaps implicit modification, is to *refrain* from adding the mask to the L2 regularizer, as would be intuitive according to earlier equation 5, where the MADE mask operates on the Base parameters in conjunction with the FedWeIT mask. The reasoning here is two-fold. First, the sum operates over previous time steps, and as such a current steps’ MADE mask would mask a different portion of parameters and thus interfere. Naturally, this could be solved by also storing respective MADE masks in the knowledge base, at the expense of larger memory and communication overheads. However, and interestingly, one can realize that we also do not need the MADE masking in this term. On the one hand, the A_c parameters up to $t - 1$ have already been largely sparsified through the Ω -term. On the other hand, before computing the actual L2 term between the base and task-adaptive parameters, a difference in the level of B_c and A_c is taken individually first (ΔB_c & ΔA_c). By definition, masking a value to be zero does not contribute to differences or sums and vice-versa if a respective weight had indeed been masked and received no update, its difference between time steps would be zero independently of its exact value. Overall, CONFEDMADE thus involves the following communication:

Cost of communication at end of round r: Participating clients communicate the local base parameters to the server and the server sends back the averaged global parameter. The client’s cost is ($\bar{B}_c * |r|$), where $|r|$ is the total number of communication rounds (linked to SGD steps) and \bar{B}_c is a masked subset ($|B_c \odot m_c \odot M^W|$) for each client. In reference to the original FedWeIT, the amount of communicated (non-zero) parameters is thus reduced through MADE. The server’s cost is ($\bar{W}_G * |r| * |C|$), where \bar{W}_G denotes the averaged local base parameter and $|C|$ the number of clients.

Cost of communication at end of round t: After completion of r “inner” communication rounds, clients communicate the learned task-specific representations A_c , and the server maintains a memory, which it communicates to the clients at the beginning of task t+1. Total communication cost accounts to $|C| * (|R| * |W_G| + A_c)$. For reference, a communication overhead of a typical FL approach is $|C| * (|R| * \theta)$ where θ is the full set of model parameters without decomposition or subset masking.

4 Experimental Analysis

We empirically corroborate the advantages of CONFEDMADE in three different dataset sequences and respectively contrast it with baseline approaches. Specifically, we quantify how i) forgetting is mitigated ii) adaptive task knowledge is attended to, and iii) communication costs are reduced.

Table 2: Average final negative log-likelihoods and forgetting values (lower is better) for different learning settings and models. CONFEDMADE improves substantially through the symbiosis of auto-regressive masking and parameter decomposition, approaching the upper-bound more closely than an unsupervised FedWeIT.

Learning Setting	FL	CL	MNIST		Binary		MNIST, EMNIST	
			NLL (\downarrow)	Forgetting (\downarrow)	NLL (\downarrow)	Forgetting (\downarrow)	NLL (\downarrow)	Forgetting (\downarrow)
Offline	×	×	72.68 \pm 1.68	—	38.45 \pm 1.33	—	84.98 \pm 1.21	—
Federated Offline	✓	×	79.23 \pm 1.11	—	40.33 \pm 0.88	—	89.66 \pm 3.12	—
CL-UB	×	✓	73.32 \pm 1.23	0.00 \pm 0.00	39.45 \pm 0.37	0.00 \pm 0.00	86.66 \pm 3.12	0.00 \pm 0.00
CL-LB	×	✓	126.1 \pm 3.32	38.62 \pm 2.76	81.32 \pm 0.97	28.32 \pm 1.23	125.3 \pm 2.76	30.98 \pm 0.43
FedCL-UB	✓	✓	74.47 \pm 0.57	0.00 \pm 0.00	41.67 \pm 1.26	0.00 \pm 0.00	87.34 \pm 2.24	0.00 \pm 0.00
FedCL-LB	✓	✓	115.3 \pm 5.67	31.43 \pm 1.21	84.45 \pm 0.45	29.56 \pm 2.54	129.8 \pm 3.21	36.98 \pm 1.02
FedWeIT-MADE	✓	✓	99.32 \pm 1.97	19.43 \pm 1.11	69.23 \pm 0.66	18.02 \pm 0.97	114.6 \pm 0.65	20.24 \pm 0.37
FedWeIT-MADE*	✓	✓	93.32 \pm 2.70	14.43 \pm 0.87	63.83 \pm 1.12	12.40 \pm 0.87	109.3 \pm 3.54	15.11 \pm 0.71
CONFEDMADE	✓	✓	87.12 \pm 2.76	8.32 \pm 0.76	59.15 \pm 0.67	8.12 \pm 0.43	104.2 \pm 3.10	9.76 \pm 0.87



Figure 3: Decomposed negative log-likelihood in FCL to showcase: (left) average of tasks seen so far, (center) the “base” loss, i.e. the value for only initial task in evolution over time to assess forgetting, (right) the “new” loss, i.e. the value for only the newest task to gauge encoding of new knowledge. Lower values are better.

4.1 Learning settings and compared approaches

Dataset sequences. We construct three sequences of unsupervised tasks, ranging from images to numerical data. *A) Sequential MNIST:* comprised of 10 distinct digit classes, we consider 5 consecutive tasks per client to each consist of images with a single random digit. *B) Numerical binary data:* we create sequences across four popular binary datasets from distribution estimation literature, namely “RCV1”, “Adult”, “Connect4”, and “Tretail” Uria et al. (2016); Dua & Graff (2017) with 100000 data instances in total. At each timestep, a client is trained on only one of these numerical datasets. *C) MNIST + EMNIST:* With 36 distinct subsets, 10 digits and 26 letters, and a total of 215,600 data samples, a client observes mutually exclusive samples from either digits or letters as a task. We emphasize that we refer to labels only for the sake of intuition in formulating sequences of tasks for clients, not for the fully unsupervised optimization (no task conditioning, labels, etc.). We defer to the supplementary material for detailed descriptions of constructed sequences.

Learning settings and respective models. We contrast CONFEDMADE with FedWeIT in the continual federated setting and relate it to offline scenarios and respectively achievable lower- and upper-bound baselines. Specifically, we consider *1) Offline:* a standard MADE Germain et al. (2015), as optimized on the entire dataset in a traditional training regime. *2) Federated Offline:* similar to the before scenario, but with all data being evenly distributed across clients at the start, following the FedAvg MADE introduced in section 3.2 (with ablation study insights). *3) Continual lower- and upper-bounds (CL-LB & CL-UB):* in CL-LB data is presented incrementally without revisits or employing any strategy for continual updates, expecting full catastrophic forgetting in a standard MADE model (with only 1 client). CL-UB represents the best-case continual learning scenario, where data is introduced incrementally but accumulated over time, hence without incurring any forgetting. *4) Continual Federated lower- and upper-bounds (FedCL-LB & FedCL-UB):* Combines continual and federated scenarios, where the upper-bound again accumulates all data individually per MADE client and the lower-bound swaps out all data without. Again, in the spirit of bounds, the best model of section 3.2 is used. *5) FedWeIT-MADE and CONFEDMADE in CFL:* full continual federated learning (without data revisits) and mitigated forgetting through a) a naive combination of FedWeIT and MADE, without insights of section 3.2 and naive application of eq. 2, b) FedWeIT-MADE*, now including the ablation insights of section 3.2 to highlight their importance, c) our full CONFED-

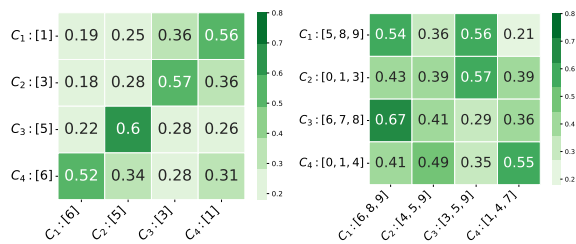

Figure 4: Heatmaps for values of α (range 0 to 1) to highlight inter-client knowledge transfer when other clients have observed the same tasks (left) or have partial overlap (right). Two tasks for individual clients are denoted in brackets on x and y-axes respectively.

Table 3: Sparsification/Performance trade-off to reduce communication through CONFEDMADE’s M^W and increased cut-off for FedWeIT m_c . Whereas m_c by itself lightly improves communication at minor performance expense, CONFEDMADE lowers communication by almost 50% at virtually no drop in NLL.

Comm. strategy	% of B_c	NLL
w/o M^W & $m_c > 0.1$	88.6	85.89 \pm 0.67
w/ M^W & $m_c > 0.1$	44.5	87.12 \pm 0.83
w/ M^W & $m_c > 0.2$	39.4	88.52 \pm 0.44
w/ M^W & $m_c > 0.3$	34.7	90.08 \pm 0.57
w/ M^W & $m_c > 0.4$	30.0	91.12 \pm 0.89

-MADE approach, based on proposed eq. 6. We typically assume 5 clients and clients’ participation in each communication round in all federated (continual) scenarios. For simplicity, each consecutive task is trained for 50 communication rounds, where each round is equivalent to one epoch.

4.2 Efficiently mitigating forgetting with CONFEDMADE across three data scenarios

We present the final averaged log-likelihoods and forgetting values for all of our three sketched data sequences in experimental table 2. Starting with the full data learning scenarios, we can see that a single client (offline) is only marginally better than the federated and continual learning upper-bounds. Without constraints imposed on data seen by clients, it is understandable that these set the benchmark on achievable results with a MADE architecture.

We continue to notice the non-surprising opposite trend with MADE in incremental and federated learning scenarios in their lower-bounds (CL-UB and FedCL-UB), where previously seen data samples are no longer continuously repeated with newly encountered data. Here, the frameworks naturally succumb to large catastrophic forgetting, as observed in the NLL-losses deteriorating to 115.31 and 126.12 compared to 74.47 and 73.32 respectively. The naive FedWeIT-MADE already shows significant signs of improvement in the performance, highlighting earlier intuition that masked autoencoders are effective together with parameter decomposition in CFL scenarios. Most importantly, however, upon enforcing the strategies discussed in section 3.3 we see an additional improvement in the catastrophic forgetting as conceptualized in FedWeIT-MADE*. With our full CONFEDMADE, pertaining to the modifications in the sparsity-inducing regularizer, the impact of the knowledge base is further boosted and performance over its two counterparts improved by roughly 6.0 and 10.0 nats.

To further nuance these statements, figure 3 shows the evolution of a decomposed loss after each task, separately quantifying average performance, forgetting the first task, and encoding new knowledge. We can observe that FedMADE forgets more of the learned representations of task 0 as we progress to learn. Although CONFEDMADE is yet to reach the full upper bounds, it certainly reduces the gap to what can be achieved, while widening the gap with lower bounds with a big difference of up to 20.00 in forgetting. Overall the choices in section 3 (in the initial FedMADE) and the CONFEDMADE loss both meaningfully and significantly improve upon a FedWeIT baseline.

CONFEDMADE attends to overlapping knowledge of other clients: To illustrate the effect of the inter-client transfer of learned representations, we plot the ‘attention’ values α at the end of two tasks (one task on each axis) in the form of heatmaps in figure 4. In the figure’s left panel, the tasks are set up in a way that there is a complete overlap of data subsets, whereas the right panel contains partial overlap among the clients. As such, we can investigate the strength of a CONFEDMADE client to decide when the shared knowledge across the network can aid its own training. Overall, we can observe higher values of α (0.60 and 0.67) in the respective plots when there is overlap in the data subsets and thus later mitigated forgetting, and values as low as 0.19 or 0.21 when there is no overlap.

CONFEDMADE reduces the cost of communication by actively masking model parameters: As base parameters B_c largely account for the communication cost of CONFEDMADE (A_c is generally small), we investigate the sparsification/performance trade-off by ablating the auto-regressive MADE mask (M^W) and modulating the cut-off value for the FedWeIT mask (m_c) on MNIST in table 3. Intuitively, we first quantify how much sparsification we can achieve at which cost through our inclusion of the auto-regressive masking. Here, we observe that we gain a substantial, almost half,

reduction in the communicated amount of B_c at virtually no performance drop. In contrast, setting higher cut-offs on the FedWeIT mask (0-1 range), results in only a small further reduction of communication cost, with similar minor drops in performance. Despite this advantage seeming almost negligible in relation to the major gains obtained through MADE in CONFEDMADE, we can nevertheless observe that both masking strategies together are symbiotic.

5 Conclusion

We have shown that masked autoencoders are effective continual federated learners by synergizing the benefits of auto-regressive masking with FedWeIT’s parameter decomposition framework. Empirical evaluations on a range of image to numerical data have demonstrated that our introduced CONFEDMADE approach mitigates forgetting while lowering communication costs. However, our investigation has presently been limited to MLPs, to highlight the framework’s key elements. One natural next step is thus to scale to large-scale transformer architectures, where recent work has corroborated masked autoencoding as an effective strategy on a token basis He et al. (2022). The respective approach can seamlessly be integrated with CONFEDMADE, allowing future investigation into clients that may additionally observe not only different distributions but also multiple modalities.

Acknowledgements

This work was supported by the project “safeFBDC - Financial Big Data Cluster (FKZ: 01MK21002K)”, funded by the German Federal Ministry for Economics Affairs and Energy as part of the GAIA-x initiative. It benefited from the Hessian Ministry of Higher Education, Research, Science and the Arts (HMWK; project “The Third Wave of AI”), the Federal Ministry of Education and Research (BMBF) and the State of Hesse Project collaborative center “High-Performance Computing for Computational Engineering Sciences (NHR4CES)” as part of the NHR Program.

References

- Alessandro Achille, Tom Eccles, Loic Matthey, Christopher P. Burgess, Nick Watters, Alexander Lerchner, and Irina Higgins. Life-Long Disentangled Representation Learning with Cross-Domain Latent Homologies. *Neural Information Processing Systems (NeurIPS)*, 2018.
- Linda Argote and Ella Miron-Spektor. Organizational learning: From experience to knowledge. *New Perspectives in Organization Science*, 2011.
- Dana H. Ballard. Modular learning in neural networks. In *AAAI Conference on Artificial Intelligence*, 1987.
- Zhiyuan Chen and Bing Liu. Lifelong machine learning. *Synthesis Lectures on Artificial Intelligence and Machine Learning*, 2018.
- Sijie Cheng, Jingwen Wu, Yanghua Xiao, Yang Liu, and Yang Liu. Fedgems: Federated learning of larger server models via selective knowledge fusion. *arXiv preprint arXiv:2110.11027*, 2021.
- Jichan Chung, Kangwook Lee, and Kannan Ramchandran. Federated unsupervised clustering with generative models. *International Workshop on Trustable, Verifiable and Auditable Federated Learning in Conjunction with AAI 2022*, 2022.
- Gregory Cohen, Saeed Afshar, Jonathan Tapson, and André van Schaik. Emnist: an extension of mnist to handwritten letters. *arXiv preprint arXiv:1702.05373*, 2017.
- Marcos F. Criado, Fernando E. Casado, Roberto Iglesias, Carlos V. Regueiro b, and Senen Barro. Non-iid data and continual learning processes in federated learning: A long road ahead. *Information Fusion*, 2022.
- Li Deng. The mnist database of handwritten digit images for machine learning research. *IEEE Signal Processing Magazine*, 2012.
- Dheeru Dua and Casey Graff. UCI machine learning repository. “University of California, Irvine, School of Information and Computer Sciences”, 2017.

- Sebastian Farquhar and Yarin Gal. Towards Robust Evaluations of Continual Learning. *International Conference on Machine Learning (ICML), Lifelong Learning: A Reinforcement Learning Approach Workshop*, 2018.
- Robert M. French. Semi-distributed representations and catastrophic forgetting in connectionist networks. *Connection Science*, 1992.
- Mathieu Germain, Karol Gregor, Iain Murray, and Hugo Larochelle. Made: Masked autoencoder for distribution estimation. *Proceedings of the 32nd International Conference on Machine Learning*, 07–09 Jul 2015.
- Francesca Gino, Linda Argote, Ella Miron-Spektor, and Gergana Todorova. First, get your feet wet: The effects of learning from direct and indirect experience on team creativity. *Organizational Behavior and Human Decision Processes*, 2010.
- Ian J. Goodfellow, Jean Pouget-Abadie, Mehdi Mirza, Bing Xu, David Warde-Farley, Sherjil Ozair, Aaron Courville, and Yoshua Bengio. Generative Adversarial Nets. *Neural Information Processing Systems (NeurIPS)*, 2014.
- Raia Hadsell, Dushyant Rao, Andrei A Rusu, and Razvan Pascanu. Embracing change: Continual learning in deep neural networks. *Trends in cognitive sciences*, 2020.
- Sungwon Han, Sungwon Park, Fangzhao Wu, . Sundong Kim Kim, Chuhan Wu, Xing Xie, and Meeyoung Cha. Fedx: Unsupervised federated learning with cross knowledge distillation. *European Conference on Computer Vision*, 2022.
- Tyler L. Hayes, Giri P. Krishnan, Maxim Bazhenov, Hava T. Siegelmann, Terrence J. Sejnowski, and Christopher Kanan. Replay in deep learning: Current approaches and missing biological elements. *Neural Computation*, 2021.
- Kaiming He, Xinlei Chen, Saining Xie, Yanghao Li, Piotr Dollár, and Ross Girshick. Masked autoencoders are scalable vision learners. In *Proceedings of the IEEE/CVF Conference on Computer Vision and Pattern Recognition (CVPR)*, June 2022.
- Peter Kairouz, H. Brendan McMahan McMahan, et al. Advances and open problems in federated learning. *Foundations and Trends in Machine Learning*, 2021.
- Ronald Kemker, Marc McClure, Angelina Abitino, Tyler Hayes, and Christopher Kanan. Measuring catastrophic forgetting in neural networks. *arXiv preprint arXiv:1708.02072*, 2017.
- Diederik P. Kingma and Max Welling. Auto-Encoding Variational Bayes. *International Conference on Learning Representations (ICLR)*, 2013.
- James Kirkpatrick, Razvan Pascanu, Neil Rabinowitz, Joel Veness, Guillaume Desjardins, Andrei A. Rusu, Kieran Milan, John Quan, Tiago Ramalho, Agnieszka Grabska-Barwinska, Demis Hassabis, Claudia Clopath, Dharshan Kumaran, and Raia Hadsell. Overcoming catastrophic forgetting in neural networks. *Proceedings of the National Academy of Sciences*, 2017.
- Dhiresha Kudithipudi, Mario Aguilar-Simon, Jonathan Babb, Maxim Bazhenov, et al. Biological underpinnings for lifelong learning machines. *Nature Machine Intelligence*, 2022.
- Brenden M Lake, Tomer D Ullman, Joshua B Tenenbaum, and Samuel J Gershman. Building machines that learn and think like people. *Behavioral and brain sciences*, 2017.
- Daliang Li and Junpu Wang. Fedmd: Heterogenous federated learning via model distillation. *arXiv preprint arXiv:1910.03581*, 2019.
- Qinbin Li, Bingsheng He, and Dawn Song. Model-contrastive federated learning. *Proceedings of the IEEE/CVF Conference on Computer Vision and Pattern Recognition (CVPR)*, June 2021a.
- Tian Li, Anit Kumar Sahu, Manzil Zaheer, Maziar Sanjabi, Ameet Talwalkar, and Virginia Smith. Federated optimization in heterogeneous networks. *arXiv preprint arXiv:1812.06127*, 2020.
- Xiaoxiao Li, Meirui Jiang, Xiaofei Zhang, Michael Kamp, and Qi Dou. Fedbn: Federated learning on non-iid features via local batch normalization. *arXiv preprint arXiv:2102.07623*, 2021b.

- David Lopez-Paz and Marc' Aurelio Ranzato. Gradient episodic memory for continual learning. *Advances in Neural Information Processing Systems*, 2017.
- Nan Lu, Zhao Wang, Xiaoxiao Li, Gang Niu, Qi Dou, and Masashi Sugiyama. Federated learning from only unlabeled data with class-conditional-sharing clients. *International Conference on Learning Representations*, 2022.
- Ekdeep Singh Lubana, Chi Ian Tang, Fahim Kawsar, Robert P. Dick, and Akhil Mathur. Orchestra: Unsupervised federated learning via globally consistent clustering. *International Conference on Machine Learning*, 2022.
- M. McCloskey and N. J. Cohen. Catastrophic Interference in Connectionist Networks : The Sequential Learning Problem. *Psychology of Learning and Motivation - Advances in Research and Theory*, 1989.
- H. Brendan McMahan, Eider Moore, Daniel Ramage, Seth Hampson, and Blaise Aguera y Arcas. Communication-efficient learning of deep networks from decentralized data. *Proceedings of the 20th International Conference on Artificial Intelligence and Statistics (AISTATS)*, 2017.
- Martin Mundt, Steven Lang, Quentin Delfosse, and Kristian Kersting. Cleva-compass: A continual learning evaluation assessment compass to promote research transparency and comparability. *In International Conference on Learning Representations*, 2022a.
- Martin Mundt, Iuliia Pliushch, Sagnik Majumder, Yongwon Hong, and Visvanathan Ramesh. Unified probabilistic deep continual learning through generative replay and open set recognition. *Journal of Imaging*, 2022b.
- Martin Mundt, Yongwon Hong, Iuliia Pliushch, and Visvanathan Ramesh. A wholistic view of continual learning with deep neural networks: Forgotten lessons and the bridge to active and open world learning. *Neural Networks*, 2023.
- Tae Jin Park, Kenichi Kumatani, and Dimitrios Dimitriadis. Tackling dynamics in federated incremental learning with variational embedding rehearsal. *arXiv preprint arXiv:2110.09695*, 2021.
- Jason Ramapuram, Magda Gregorova, and Alexandros Kalousis. Lifelong generative modeling. *Neurocomputing*, 2020.
- Dushyant Rao, Francesco Visin, Andrei Rusu, Razvan Pascanu, Yee Whye Teh, and Raia Hadsell. Continual unsupervised representation learning. *Advances in Neural Information Processing Systems*, 2019.
- Hanul Shin, Jung K. Lee, Jaehong J. Kim, and Jiwon Kim. Continual Learning with Deep Generative Replay. *Neural Information Processing Systems (NeurIPS)*, 2017.
- Karan Singhal, Hakim Sidahmed, Zachary Garrett, Shanshan Wu, John Rush, and Sushant Prakash. Federated reconstruction: Partially local federated learning. *Advances in Neural Information Processing Systems*, 2021.
- Benigno Uribe, Marc-Alexandre Côté, Karol Gregor, Iain Murray, and Hugo Larochelle. Neural autoregressive distribution estimation. *arXiv preprint arXiv:1605.02226*, 2016.
- Anastasiia Usmanova, Francois Portet, Philippe Lalanda, and German Vega. A distillation-based approach integrating continual learning and federated learning for pervasive services. *Third Workshop on Continual and Multimodal Learning for Internet of Things at IJCAI*, 2021.
- Bram van Berlo, Aaqib Saeed, and Tanir Ozcelebi. Towards federated unsupervised representation learning. *EdgeSys 2020: Proceedings of the Third ACM International Workshop on Edge Systems, Analytics and Networking*, 2020.
- Daniel M. Wegner. Transactive memory: A contemporary analysis of the group mind. *Theories of Group Behavior, Springer Series in Social Psychology*, 1987.
- Daniel M. Wegner, Toni Giuliano, and Paula T. Hertel. Cognitive interdependence in close relationships. *Compatible and Incompatible Relationships, Springer Series in Social Psychology*, 1985.

Jaehong Yoon, Eunho Yang, Jeongtae Lee, and Sung Ju Hwang. Lifelong learning with dynamically expandable networks. *arXiv preprint arXiv:1708.01547*, 2018.

Jaehong Yoon, Wonyong Jeong, Giwoong Lee, Eunho Yang, and Sung Ju Hwang. Federated continual learning with weighted inter-client transfer. *Proceedings of the 38th International Conference on Machine Learning*, 18–24 Jul 2021.

Fengda Zhang, Kun Kuang, Zhaoyang You, Tao Shen, Jun Xiao, Yin Zhang, Chao Wu, Yuet-ing Zhuang, and Xiaolin Li. Federated unsupervised representation learning. *arXiv preprint arXiv:2010.08982*, 2020.

APPENDIX

In the appendix, we complement the main body with Training setup details and hyperparameters in part A and further empirical visualization in part B.

A Training Conditions and Hyperparameters

A.1 Training Configuration:

To evaluate our various experimental setups, we have used *NVIDIA TESLA V100 - SXM3*. From the architectural point of view, a client model comprises of multi-layer perceptrons (MLP) with varied hidden layer capacities depending on the complexity of the task to be learned. To put a constraint on the the model complexity, we have largely set the depth of the hidden layers between [350, 500] for images and [90, 110] for numerical data. For the sake of simplicity, the number of clients typically ranges from 3 to 5 for our federated setups (FedCL-LB & -UB), whereas only a single client is used for continual setups (CL-LB & -UB). The duration of the experiments span from several hours to a max of 24 hours. We optimize our decomposed MADE client parameters using Adam or AdamW optimizers with the learning rate starting at 0.001 alongside a weight decay of 0.0001. We collaboratively learn individual task for 50 rounds of communication where each round resonates to only one epoch. After extensive experimental evaluation, We have opted to use 0.0001 and 100 for the hyperparameters λ_1, λ_2 respectively.

Code is available at: <https://github.com/ml-research/CONFEDMADE>

A.2 Task set Formulation

Table 4 provides the detailed description of the dataset as used in the main body. Recall, it is implied that the offline scenario uses the entire dataset, whereas continual lower and upper-bounds makes use of the respectively sketched tasks. The reader is reminded that the sequences of tasks are presented in isolation for the lower bound and concatenated (accumulated) for the upper bound.

A.3 Evaluation Measures

In our main body’s experiments, we have considered two sets of evaluation measures to compare our techniques. The first is based on the decomposition of the loss to measure the old and the new task Kemker et al. (2017). The second is based on the notion of forgetting Lopez-Paz & Ranzato (2017).

Average per-task Negative log-likelihood loss: We measure the reconstruction loss at the end of the task t averaged over all the previous tasks. $N_t = 1/t \sum_{i=1}^t n_{t,i}$ where $n_{t,i}$ is the Negative log-likelihood (NLL) loss of task i after the completion of t .

Base Task loss: With this measure, we measure the ability of our frameworks to retain the information learned during the first task set at a future time step. Base task loss can be defined as $B_t = n_{t,0}$ where $n_{t,0}$ is the Negative log-likelihood of task 0 after the completion of task t .

New Task loss: We also measure the model’s capability to generalize on newly seen data samples. The New task loss for a client model can be defined as $N_t = n_{t,t}$ where $n_{t,t}$ is the Negative log-likelihood for task t after the completion of task t .

Average forgetting: We measure the forgetting in terms of the difference in the negative log-likelihood loss for the task i after the completion of task t and its base task loss. For T tasks, Average forgetting can be defined as $F_t = 1/(t - 1) \sum_{i=1}^{t-1} \max_{t \in 1..T-1}(0, n_{t,i} - n_{T,i})$ where $n_{t,i}$ is the negative log-likelihood for task i after the completion of task t .

Table 4: Details of the various dataset used in this work. The datasets range from MNIST, EMNIST to numerical datasets such as Adult, Connect4, etc. We have also stated total no of distinct subsets in each dataset (No. Classes), Sequence of tasks created (No. Tasks), number of distinct data subsets used per task (Classes per task). The train-validation-test splits can be visualized in the following Train, Validation, and Test columns.

DATASETS						
Dataset	No. Tasks	No. Classes	Classes per task	Train	Validation	Test
MNIST Deng (2012)	5	10	3	15620	3121	3120
MNIST Deng (2012)	5	10	1	5626	1126	1127
EMNIST Cohen et al. (2017)	5	10	13	42817	8564	8563
Adult Dua & Graff (2017)	4	1	1	23257	4653	4651
Connect4 Dua & Graff (2017)	4	1	1	48255	9651	9651
Tretail Dua & Graff (2017)	4	1	1	20990	4199	4198
RCV1 Dua & Graff (2017)	4	1	1	34285	6858	6857

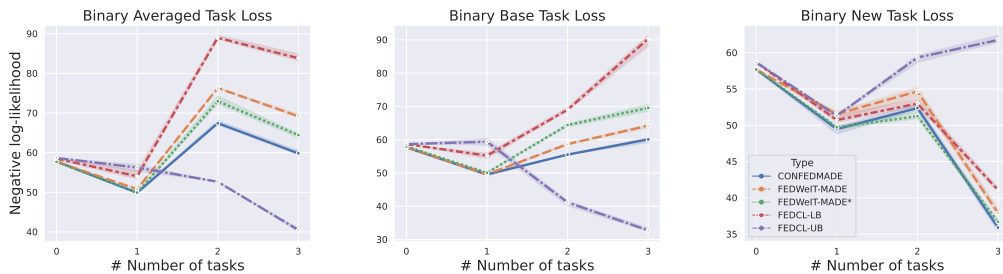

Figure 5: Decomposed negative log-likelihood in FCL for binary datasets to showcase: (left) average of tasks seen so far, (center) the “base” loss, i.e the value for only initial task in evolution over time to assess forgetting, (right) the “new” loss, i.e. the value for only the newest task to gauge encoding of new knowledge. Lower values are better.

A.4 Empirical Visualization

Recall in the main body, we have visualized the effectiveness of CONFEDMADE against other approaches for Sequential MNIST dataset Deng (2012). To further validate that we can scale our proposed approach against different data distributions, we produce the three similar plots for Binary datasets based on Average task loss, Base task loss and New task loss. If we refer to the first plot on the left (Average task loss), CONFEDMADE can be seen to retain previously learned representations much more efficiently compared to its other counterparts under similar continual lower-bound scenario. Thereby, we can establish CONFEDMADE as effective continual federated learner, pertaining to our continual and auto-regressive masking strategies.