

# Improved Cross-Lingual Transfer Learning For Automatic Speech Translation

Sameer Khurana, Nauman Dawalatabad, Antoine Laurent, Luis Vicente, Pablo Gimeno, Victoria Mingote, James Glass

**Abstract**—Research in multilingual speech-to-text translation is topical. Having a single model that supports multiple translation tasks is desirable. The goal of this work is to improve cross-lingual transfer learning in multilingual speech-to-text translation via semantic knowledge distillation. We show that by initializing the encoder of the encoder-decoder sequence-to-sequence translation model with SAMU-XLS-R, a multilingual speech transformer encoder trained using multi-modal (speech-text) semantic knowledge distillation, we achieve significantly better cross-lingual task knowledge transfer than the baseline XLS-R, a multilingual speech transformer encoder trained via self-supervised learning. We demonstrate the effectiveness of our approach on two popular datasets, namely, CoVoST-2 and Europarl. On the 21 translation tasks of the CoVoST-2 benchmark, we achieve an average improvement of 12.8 BLEU points over the baselines. In the zero-shot translation scenario, we achieve an average gain of 18.8 and 11.9 average BLEU points on unseen medium and low-resource languages. We make similar observations on Europarl speech translation benchmark.

**Index Terms**—Cross-Lingual Transfer Learning, Automatic Speech Translation, Semantically Aligned Cross-Lingual Speech Representations

## I. INTRODUCTION

Self-Supervised Representation Learning (SSRL) from speech [1]–[18] has improved tremendously over the past few years due to the introduction of Contrastive Predictive Coding (CPC) [19], a self-supervised representation learning method applied to speech, text, and visual data. The introduction of the core idea of *noise contrastive estimation* [20] in CPC has led to a series of papers in speech SSRL, such as Wav2Vec [5], VQ-Wav2Vec [6], Wav2Vec-2.0 [9], Multilingual Wav2Vec-2.0 [11], XLS-R (XLS-R, a bigger version of the multilingual wav2vec-2.0) [15]. Pre-trained SSRL speech encoders like XLS-R are considered "foundation models" [21] for downstream multilingual speech processing applications such as Multilingual Automatic Speech Recognition [11], [15], [22], Multilingual Speech Translation [15], [18], [23], and other para-linguistic property prediction tasks [24], [25]. This work focuses on Multilingual Speech Translation.

Multilingual Speech Translation (MST) refers to translating speech in all the source languages in set  $\mathcal{X}$  to text in all the target languages in set  $\mathcal{Y}$ , which implies a total of  $|\mathcal{T}| =$

$|\mathcal{X}| \times |\mathcal{Y}|$  translation tasks. In MST, we train a single model for all the translation tasks given by set  $\mathcal{T}$ . The benefits of having a single model instead of individual model for each task  $t \in \mathcal{T}$  are two-fold: First, it is convenient to maintain and share a single model that can perform multiple tasks rather than having  $|\mathcal{T}|$  separate models, and second, sharing model parameters amongst  $|\mathcal{T}|$  translation tasks could lead to knowledge transfer across tasks, especially from high-resource to low-resource.

The standard neural network architecture used for MST is the *encoder-decoder* model [26], [27]. Recently, MST has seen significant improvements owing to; (i) better initialization of the translation model's encoder and decoder with pre-trained speech encoders, like XLS-R [15], and text decoders, like MBART [28], (ii) better fine-tuning strategies [23], and (iii) parallel speech-text translation corpora [29], [30]. However, as we demonstrate in Section II, the performance on low-resource tasks remains poor, and in particular, the performance gap (cross-lingual transfer gap) between high and low-resource languages remains large. We hypothesize that this is because the XLS-R speech encoder learns non-robust *surface-level features* from unlabeled speech data, rather than the high-level linguistic knowledge about *semantics*.

To inject semantic knowledge into the learned XLS-R representations, we turn to the recently introduced Semantically-Aligned Multimodal Cross-Lingual Representation Learning framework, SAMU-XLS-R [17]. SAMU-XLS-R (Section III-B) is a *knowledge-distillation* framework that distills semantic knowledge from a pre-trained text embedding model into the pre-trained multilingual XLS-R speech encoder. The KD framework outputs the SAMU-XLS-R speech encoder that learns a semantically structured multilingual speech manifold, where a spoken utterance is close to its spoken translations in several other languages that are present in the SAMU-XLS-R's training pool (Details in Section III-B). We **claim** that building MST model using the semantic representations learned by SAMU-XLS-R would lead to better cross-lingual transfer from high to low-resource tasks compared to the XLS-R and other non-semantic multilingual speech encoder baselines. We verify our claim through several experiments (Section VI). Through this work, we make the following **contributions**:

- We doubled the number of languages previously supported by SAMU-XLS-R encoder from 25 to 53 (Section IV-A).
- SAMU-XLS-R encoder provides speech embedding at the utterance level. Previous works [31] have explored the use of SAMU-XLS-R embedding for automatic spoken language understanding and semantic speech-text and speech-speech retrieval [17]. Differently, in this work, for the first

Sameer Khurana (email: skhurana@mit.edu), Nauman Dawalatabad, and James Glass are with MIT Computer Science and Artificial Intelligence Laboratory, USA. Luis Vicente, Pablo Gimeno, and Victoria Mingote are with the University of Zaragoza, Spain. Antoine Laurent is with LIUM University, France. This work was partially performed using HPC resources from GENCI-IDRIS, grants AD011012527 and AD011012565. This work has received funding from the European Union's Horizon 2020 research and innovation programme under the Marie Skłodowska-Curie grant agreement No 101007666.

time, we show that the fine-grained contextual embeddings (corresponding to 20ms duration speech segment) that precede the coarse utterance level representation (3-10s long speech segment) learned by SAMU-XLS-R is well-suited for the sequence generation task of multilingual speech translation. We empirically demonstrate, through several experiments, the superiority of SAMU-XLS-R representations over XLS-R and other multilingual speech encoders (Section VI).

- On the public CoVoST-2  $\mathcal{X} \rightarrow$  English MST benchmark [30], we show that by switching the XLS-R encoder in the MST model to the SAMU-XLS-R encoder, the performance improves significantly on medium-resource  $\mathcal{X} \rightarrow$  English language group by 15.6 BLEU points, and on low-resource language group by 18.9 BLEU points, and overall by 13.8 BLEU points (Section VI-A).
- We also show the efficacy of the SAMU-XLS-R speech encoder in Zero-Shot translation settings. In the Zero-Shot MST scenario, where we train the SAMU-XLS-R-based MST model only on high-resource  $\mathcal{X} \rightarrow$  English tasks in CoVoST-2, we observe an improvement on medium and low-resource tasks of 18.8 and 11.9 BLEU points over the XLS-R baseline (Section VI-B).
- Finally, we extend our studies on another MST benchmark, namely Europarl [29], which consists of several  $\mathcal{X} \rightarrow \mathcal{Y}$  translation tasks. In the zero-shot MST scenario, we observe an overall improvement of 8.5 BLEU points average with SAMU-XLS-R encoder over XLS-R, owing to the significant increase in performance on unseen (during training) source languages of 17 BLEU points (Section VI-C).

## II. MOTIVATION: CROSS-LINGUAL TRANSFER GAP

To motivate our work, we show the performance of the multilingual XLS-R speech encoder on the CoVoST-2 speech-to-text translation benchmark [30]. CoVoST-2 comprises 21  $X \rightarrow EN$  speech-to-text translation tasks, where  $X$  refers to the language of speech utterance, and  $EN$  refers to the corresponding English text translation. XLS-R speech encoder is pre-trained via Self-Supervised Learning using unlabeled speech data in 128 languages. Babu et al. [15] fine-tunes the pre-trained XLS-R encoder combined with a pre-trained MBART text decoder [28] simultaneously on 21  $X \rightarrow EN$  translation tasks (multi-task learning) in CoVoST-2 benchmark. We categorize the 21 translation tasks into high, mid, and low-resource groups. A task is classified as high if it has more than 100 hours of paired speech(X)-text(EN) translation training data, mid if training data is between 10 and 100 hours, and low if training data is less than 10 hours. There are four high, five mid, and 12 low-resource tasks.

We report the XLS-R (speech encoder)  $\rightarrow$  MBART (text decoder) transformer model’s performance on the high, mid, and low-resource translation groups in Fig. 1. We report the average BLEU-4 score on each translation group. The vital thing to observe is the performance gap (cross-lingual transfer gap) between high and low-resource translation groups for different-sized XLS-R encoders ranging from 300M to 2B

Fig. 1: We report translation performance on 21  $X \rightarrow EN$  speech-to-text translation tasks in CoVoST-2 benchmark with different sized pre-trained XLS-R encoders fine-tuned on labeled speech translation data. The 21 tasks are categorized into high, mid, and low resource tasks depending on the available labeled training data for a task. We report average BLEU-4 scores in the three categories. The important thing to consider is the performance gap or cross-lingual transfer gap between high and low-resource translation tasks. We address this large gap in this paper.

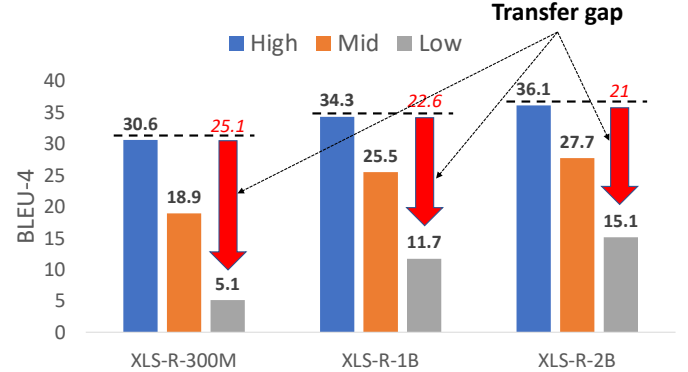

parameters. So, increasing the model size from 300M to 2B, a more than 500% increase leads to only a 16% reduction in the cross-lingual transfer gap. Since the translation model is built on top of the pre-trained XLS-R encoder’s representations, there is some missing ingredient in the pre-trained representations that leads to a poor cross-lingual transfer from high to low-resource tasks. This implies that the knowledge that the XLS-R-based translation model acquires while learning to perform high-resource  $X \rightarrow EN$  translation tasks is not useful (or transferable) for learning the low-resource tasks.

We **claim** that the missing piece is semantic knowledge. We hypothesize that since SAMU-XLS-R is specifically trained to encode semantic information in its internal representations, building a translation model on top of SAMU-XLS-R would lead to better cross-lingual transfer from high to low-resource translation tasks, thus reducing the cross-lingual transfer gap mentioned above.

## III. PRELIMINARIES

### A. XLS-R (XLS-R)

This section discusses the architecture of the XLS-R encoder. The XLS-R encoder consists of a Convolutional Neural Network (CNN) [33] feature extractor, denoted by  $h$ , and a transformer encoder [27], denoted by  $g$ .

1) *CNN Feature Extractor*:  $h : \mathbf{a}_{1:S} \rightarrow \mathbf{f}_{1:T}$  maps the speech waveform ( $\mathbf{a}_{1:S} \mid \mathbf{a}_s \in \mathbb{R}$ ) to an intermediate representation ( $\mathbf{f}_{1:T} \mid \mathbf{f}_t \in \mathbb{R}^d$ ), where  $T = S/r$ , where  $r$  is the factor by which  $h$  downsamples  $\mathbf{a}_{1:S}$ , and  $d$  is the size of the feature dimension. For the XLS-R encoder,  $r = 320$ , and  $d = 1024$ . The feature extractor  $h$  consists of seven temporal Convolution layers (CONV). Each layer uses GeLU activation function [34]. The feature maps outputted by each layer have

Fig. 2: SAMU-XLS-R *semantic knowledge-distillation* framework. The learning framework comprises a speech and a text encoder. The speech encoder transforms a raw speech waveform into an embedding vector. The text encoder transforms the transcript corresponding to the speech utterance into an embedding. The text encoder is initialized using the pre-trained Language-Agnostic BERT Sentence Embedding model LaBSE [32]. The speech encoder below the pooling layer is initialized using the pre-trained XLS-R speech encoder [15].

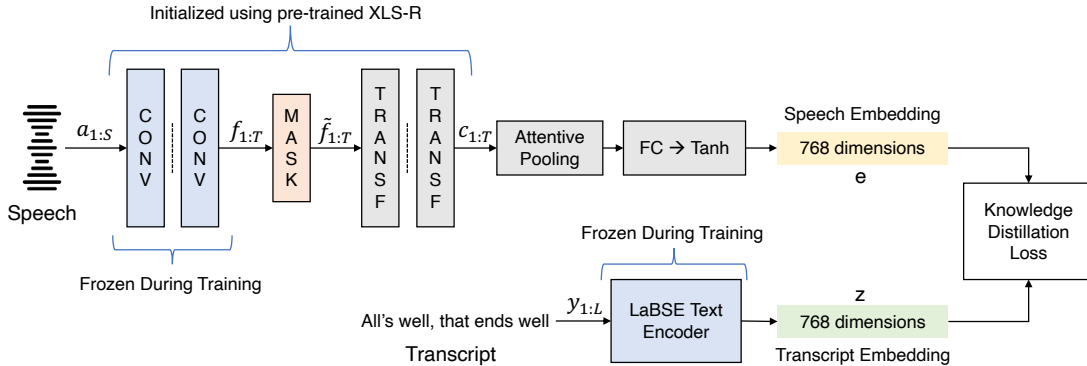

512 channels. The output of the last CONV layer in  $h$  is up-projected using a fully-connected layer (FC) so that the feature vector  $f_t$  has the same dimension as the transformer encoder. Note that the receptive field of each feature vector is 20ms of the input speech waveform. The feature extractor is followed by another CONV layer that encodes the relative position of the feature sequence  $\mathbf{f}_{1:T}$ , which is used as input to the transformer encoder  $g$ .

2) *Transformer Encoder*:  $g : \mathbf{f}_{1:T} \rightarrow \mathbf{c}_{1:T}$  maps  $(\mathbf{f}_{1:T} \mid \mathbf{f}_t \in \mathbb{R}^d)$  to contextualized representation  $(\mathbf{c}_{1:T} \mid \mathbf{c}_t \in \mathbb{R}^d)$ . The receptive field of each context vector  $\mathbf{c}_t$  is equal to the length of the input speech waveform  $\mathbf{a}_{1:S}$ , which is usually 5-10s. The transformer encoder consists of 24 layers. Each transformer layer consists of Multi-Headed Self-Attention (MHSA), followed by two FC layers. Layer Normalization (LN) is used at the input of MHSA and FC blocks. Residual connections adds the input of MHSA, with its output, and the input of FC block with its output. The transformer encoder layer dimension is 1024 (size of the feature vector outputted by a transformer layer), and the FC layer dimension is 3072. Each MHSA block consists of 16 attention heads. The output of the first FC layer is processed by a ReLU non-linearity [35].

3) *Training Details*: XLS-R is pre-trained on approximately 400K hours of multilingual *unlabeled* speech data segmented into utterances of size 3-10s. The training data consists of unlabeled speech in 128 languages coming from the following corpora: VoxPopuli [36], CommonVoice (CoVo) [37], Multilingual Speech (MLS) [38], BABEL, and Voxlingua [39]. For full training details, see [15]. We use the pre-trained XLS-R checkpoints publicly released<sup>1</sup>.

As baselines for multilingual X $\rightarrow$ EN speech translation experiments (Section VI-A), we use the XLS-R $\rightarrow$ MBART translation models that are trained on CoVoST-2 X $\rightarrow$ EN MST benchmark, officially released here<sup>2</sup>. The official release comprises three translation models corresponding to 0.3B, 1B, and

2B parameter XLS-R speech encoders. The text decoder in all three cases in the 400M parameter MBART decoder.

## B. SAMU-XLS-R (SAMU-XLS-R)

XLS-R encoder’s representation manifold encodes low-level linguistic knowledge, as evident by the non-existent cross-lingual semantic speech retrieval capability when using XLS-R’s learned representations in [17]. SAMU-XLS-R is a bimodal (speech & text) *knowledge distillation* (KD) framework for expanding the representation space of XLS-R speech encoder also to encode high-level semantic knowledge. The SAMU-XLS-R learning framework uses multilingual transcribed speech set  $\mathcal{D} = \{\mathbf{a}_{1:S}^n, \mathbf{y}_{1:L}^n\}_{i=1}^N$  consisting of speech,  $\mathbf{a}_{1:S}^i$  paired with its text transcript  $\mathbf{y}_{1:L}^i$ . Note that speech and its transcript are in the same language. The SAMU-XLS-R KD framework consists of a speech and a text processing branch as illustrated in Figure 2, and detailed below.

1) *The Speech Branch*: The speech branch maps the speech waveform  $\mathbf{a}_{1:S}$  of duration 3-10s to a single embedding vector  $\mathbf{e} \in \mathbb{R}^{768}$ . The mapping is performed in the following two steps: (i) The pre-trained XLS-R speech encoder maps  $\mathbf{a}_{1:S}$  to the contextualized representation  $\mathbf{c}_{1:T}$ , and (ii) An attention-based *temporal pooling* [40], and a non-linear ( $\tanh$ ) down-projection layer transforms  $\mathbf{c}_{1:T}$  to a single embedding  $\mathbf{e}$  of size 768.

2) *The Text Branch*: The text branch consists of a pre-trained LaBSE sentence embedding encoder [32] that transforms the text transcript  $\mathbf{y}_{1:L}$  to a semantic embedding  $\mathbf{z} \in \mathbb{R}^d$ , of size  $d = 768$ . LaBSE supports 109 written languages. It embeds sentences from different languages in a shared semantic embedding space, i.e., a sentence and its translation lie close together in the LaBSE embedding space. By regressing on the LaBSE semantic embedding, the XLS-R speech encoder learns to encode semantics hidden in the spoken utterance in its internal representations. This new *semantics-aware* speech encoder is referred to as SAMU-XLS-R encoder.

3) *Training Details*: The SAMU-XLS-R encoder is trained to minimize the cosine distance between the speech and the

<sup>1</sup><https://github.com/facebookresearch/fairseq/tree/main/examples/wav2vec/xlsr>

<sup>2</sup><https://huggingface.co/facebook/wav2vec2-xls-r-300m-21-to-en>

TABLE I: The number of hours of transcribed speech data available for training SAMU-XLS-R in each of the 53 languages from the CommonVoice-Version8 corpus.

ar	be	bg	ca	cs	cy	da	de	el	en	eo
85.2	903.9	8.2	916.8	54.9	116.3	6.6	1062.8	15.9	2185.8	1407.9
es	et	eu	fa	fi	fr	fy-NL	ga-IE	gl	ha	hi
404.6	33.0	98.9	317.3	8.5	826.1	49.6	4.3	10.2	3.4	11.7
hu	id	it	ja	ka	kmr	ky	lt	lv	mn	mt
19.9	25.8	310.6	40.8	7.6	47.0	37.2	17.4	7.1	12.4	8.3
nl	pl	pt	ro	ru	rw	sk	sl	sv-SE	sw	ta
98.0	142.2	112.0	15.8	162.6	2000.7	17.7	9.6	40.8	146.8	217.7
th	tr	tt	ug	uk	uz	vi	zh-CN	zh-HK	zh-TW	
142.1	65.1	29.2	59.8	63.4	81.0	4.5	68.0	99.7	62.6	

text embedding  $\mathbf{e}$ , and  $\mathbf{z}$  respectively (see Figure 2). The *loss function* is given by:

$$\mathcal{L} = \beta * \left( 1.0 - \frac{\mathbf{e} \cdot \mathbf{z}}{\|\mathbf{e}\| \|\mathbf{z}\|} \right) \quad (1)$$

Where  $\beta$  is used to scale up the magnitude of the cosine distance loss, a small loss magnitude could lead to extremely small gradient update values and significantly longer training times. Upscaling the loss by a constant  $\beta$  could alleviate this problem. The parameters of the speech branch are tuned to minimize the above-mentioned loss  $\mathcal{L}$ . The text encoder LaBSE remains fixed during training along with the feature extractor  $h$  of the pre-trained XLS-R encoder (See Figure 2 and [17] for training details).

#### IV. METHOD

##### A. Expanding SAMU-XLS-R

We double the number of languages supported by SAMU-XLS-R to 53 than the 25 supported previously. For training SAMU-XLS-R, we use speech utterances from multiple languages annotated with their text transcripts in the same language. We refer to SAMU-XLS-R’s training data pool as Background (BKG) data. BKG data depends on the downstream MST task domain. Ideally, we would like BKG data from the same domain as the MST task (in-domain). We use the multilingual transcribed speech from the CommonVoice-Version8 (CoVo-V8) corpus [37]. CoVo-V8 consists of transcribed speech in 87 languages (26 language families). Around 53 languages overlap with the language set supported by Language-Agnostic BERT Sentence Encoder (LaBSE), which provides semantic supervision for training the SAMU-XLS-R speech encoder. The 53 languages are: Arabic (ar), Belarusian (be), Bulgarian (bg), Catalan (ca), Czech (cs), Welsh (cy), Danish (da), German (de), Greek (el), English (en), Estonian (eo), Spanish (es), Estonian (et), Basque (eu), Persian (fa), Finnish (fi), French (fr), Western Frisian (fy-NL), Gaelic (ga-IE), Galician (gl), Hausa (ha), Hindi (hi), Hungarian (hu), Indonesian (id), Italian (it), Japanese (ja), Georgian (ka), Khmer (kmr), Kyrgyz (ky), Lithuanian (lt), Latvian (lv), Mongolian

(mn), Maltese (mt), Dutch (nl), Polish (pl), Portuguese (pt), Romanian (ro), Russian (ru), Kinyarwanda (rw), Slovak (sk), Slovenian (sl), Swedish (sv-SE), Swahili (sw), Tamil (ta), Thai (th), Turkish (tr), Tatar (tt), Uyghur (ug), Ukranian (uk), Uzbek (uz), Vietnamese (vi), Chinese-Mandarin (zh-CN), Chinese-HongKong (zh-HK), Chinese-Taiwanese (zh-TW). Table I presents the number of hours of transcribed speech available in each of the 53 languages for SAMU-XLS-R training. The total training hours is 12.7K. BKG data is highly imbalanced, where the majority of the data comes from a few high-resource languages. Following [17, Equation 3], we balance the BKG data to have a proportionate representation of different languages in a training mini-batch, which avoids under-fitting to low-resource languages. The up-sampling process involves repeating utterances in low-resource languages. Unlike previous work, we use offline data augmentation, namely speed perturbation [41], to improve the robustness of the learned representations to the data distribution shifts.

##### B. Translation Model

1) *Overview*: We use the standard encoder-decoder architecture for our translation model. We initialize the encoder using pre-trained SAMU-XLS-R. Following [23], the decoder is initialized with the decoder of a pre-trained text-to-text translation model, namely MBART<sup>3</sup>. The encoder-decoder model is trained using corpora that consist of tuples  $(\mathbf{a}_{1:S}, \mathbf{y}_{1:L})$ , where  $\mathbf{y}_{1:L}$  is the text translation sequence of the speech sequence  $\mathbf{a}_{1:S}$ .

2) *Training*: Given a speech-text translation pair  $(\mathbf{a}_{1:S}, \mathbf{y}_{1:L})$ , we tune the parameters of the translation model to maximize the log-probability of  $\mathbf{y}_{1:L}$  conditioned on speech utterance  $\mathbf{a}_{1:S}$  (log-likelihood). Also, we employ *label-smoothing* [42], [43], where a ground-truth  $y_l$  label is randomly replaced with the label predicted by the model  $\hat{y}_l$ . We set the probability of token replacement as 0.3. We use the Adam optimizer [44] to maximize the log-likelihood with

<sup>3</sup><https://github.com/facebookresearch/fairseq/tree/main/examples/multilingual#mbart50-models>

the optimal (according to a development set) learning rate (lr) of  $5e-4$ . We use a three-phase learning rate scheduler [9] as follows; (i) warm-up lr to  $5e-4$  for the first 10% of the training iterations, (ii) keep the lr constant for the next 40% of iterations, and (iii) decay the lr linearly for the rest of training. We use 28K training iterations and train the model on 8 A100 GPUs. A single training iteration uses a batch size of 10 minutes of speech utterances paired with their text translations. We use *mixed-precision* training style [45]; most computations are performed on half-precision floating point numbers except the final loss computation. We use the *fairseq* toolkit [46] for model training.

Following [9], we mask (time and feature dimension) the feature sequence  $\mathbf{f}_{1:T}$ , output by the CNN feature extractor of SAMU-XLS-R. The masking process is performed in the following two steps: (i) with some probability, referred to as the *masking probability*, choose a masking index, and (ii) mask  $M$  consecutive indices starting from the chosen index.  $M$  is known as the *masking span*. For the time dimension, we set 0.3 as the masking probability and the mask span of six. For the feature dimension, we set the masking probability to 0.5 and 64 as the mask span. The time and feature masking parameters are chosen according to a development set. The above-mentioned data augmentation is akin to SpecAugment [47], a commonly used speech spectrogram data augmentation method for training speech-to-text generation models.

The translation model comprises 700 million trainable parameters (300M encoder and 400M decoder parameters). We fine-tune only 75 million parameters. Most encoder parameters are fixed to the pre-trained SAMU-XLS-R parameters, and the decoder parameters are fixed to the pre-trained MBART decoder. Below we give details about encoder and decoder fine-tuning.

3) *Encoder Fine-Tuning*: We keep all the parameters of the speech encoder fixed to their pre-trained SAMU-XLS-R values. Instead, we add a small number of downstream *task-specific* parameters to each transformer layer of the speech encoder following [48]. We insert adapters, a *bottleneck* Feed-Forward layer, after the Multi-Headed Self-Attention (MHSA) and Fully-Connected (FC) blocks in each transformer layer. An adapter comprises a single hidden layer with ReLU activation. The input and the output layers have the same size. In contrast, the hidden layer is a fraction of the input layer size. We found the optimal (according to a development set) size of the hidden layer to be a fourth of the input layer size.

The motivation for using adapters is two-fold: (i) *Parameter Efficiency*: We only tune the adapter layer parameters, a fraction of the total parameters that comprise the speech encoder. In our case, the SAMU-XLS-R encoder consists of 300M parameters, and we add 75M task-specific adapter parameters. Hence, we only fine-tune the 75M parameters on the downstream task. (ii) *Avoids Knowledge Forgetting*: By freezing the encoder’s parameters to pre-trained values, we preserve the essential semantic knowledge encoded in the SAMU-XLS-R encoder that it acquired during the semantic knowledge-distillation pre-training phase. We later show (Section VI-D2) that preserving this semantic knowledge is essential to achieving good cross-lingual transfer. Hence, adapters form a crucial part of our cross-lingual transfer learning strategy. It must be noted that

research on adapters is ever-expanding. An in-depth analysis of specific adapter choices on downstream task performance is out-of-scope for this paper.

4) *Decoder Fine-Tuning*: Like the encoder, we keep most parameters fixed to their pre-trained values acquired during the multilingual text-to-text translation task. Unlike the encoder, we do not introduce any new task-specific parameters. Instead, we tune a fraction of the decoder’s parameters. Each layer in the transformer decoder consists of the Masked (causal) Multi-Headed Self-Attention (MMHSA), Encoder-Decoder Cross-Attention (CA), and two Fully-Connected (FC) blocks. The inputs to the MMHSA, CA, and FC blocks are normalized via Layer Normalization (LN) method presented in [49]. Following [23], we only tune the parameters of the LN and CA blocks. We fine-tune CA because, previously, it is trained as part of a decoder in a text-to-text translation pipeline. Hence, the CA module needs to be fine-tuned again for the downstream MST task to make it amenable to the input from the speech encoder. Moreover, we fine-tune LN because it is task and dataset-specific and empirically improves the performance of MST [23].

5) *Inference*: We use *beam search*, with a beam size of 5, to generate text translations for a given speech utterance. The inference process is *offline*, i.e., the decoder takes the full input speech utterance into account to generate the output translation. The decoder generates translation in an autoregressive manner. We do not use any *external language model* during inference.

## V. EVALUATION

### A. Translation Scenarios

We tackle the following translation scenarios in this work.

1) *Multilingual Translation*: We simultaneously train a translation model on several speech-to-text translation tasks in this scenario. E.g., we train a single model for all 21  $X \rightarrow EN$  translation tasks in the CoVoST-2 benchmark. Most of the training data come from a few high-resource translation tasks such as  $FR \rightarrow EN$  and  $DE \rightarrow EN$ , while most tasks such as  $ID \rightarrow EN$  are low-resource. In this scenario, we compare different translation models to test for cross-lingual translation task transfer from high to low-resource translation tasks.

2) *Zero-Shot Multilingual Translation*: Given a set of translation tasks, we train a translation model on a subset of the tasks while keeping the rest hidden during training in this translation scenario. E.g., we train an  $X \rightarrow EN$  speech-to-text translation model using high-resource translation tasks in the CoVoST-2 benchmark while keeping the mid and low-resource tasks unseen during training. We compare translation models for zero-shot cross-lingual task transfer in this scenario from high to mid and low-resource  $X \rightarrow EN$  translation tasks.

### B. Translation Tasks

We build translation models to tackle the following translation tasks in this work.

Fig. 3: Number of hours of labeled training data (Y-Axis) for all the 21  $X \rightarrow EN$  translation tasks in the CoVoST-2 benchmark.

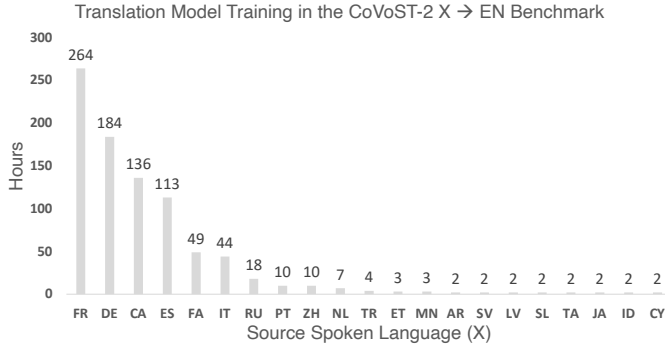

TABLE II: Training data (hours) for the 72 translation tasks  $X \rightarrow Y$  in the Europarl Speech-to-Text translation benchmark.

SRC/TGT	FR	DE	IT	ES	PT	PL	RO	NL	EN
FR	-	21	20	21	22	20	18	22	32
DE	18	-	17	18	18	17	17	18	30
IT	21	21	-	21	21	21	19	20	37
ES	14	14	14	-	14	13	12	13	22
PT	10	10	10	10	-	9	9	9	15
PL	18	18	17	18	18	-	16	18	28
RO	12	12	12	12	12	12	-	12	24
NL	5	5	4	5	4	4	4	-	7
EN	81	83	80	81	81	79	72	80	-

1)  $X \rightarrow EN$  Speech-to-Text Translation: We build translation models for the 21  $X(\text{Speech}) \rightarrow EN(\text{Text})$  translation tasks in the CoVoST-2 translation benchmark [30]. The 21 spoken languages in CoVoST-2 are French (fr), German (de), Spanish (es), Catalan (ca), Italian (it), Russian (ru), Chinese (zh), Portuguese (pt), Persian (fa), Estonian (et), Mongolian (mn), Dutch (nl), Turkish (tr), Arabic (ar), Swedish (sv), Latvian (lv), Slovenian (sl), Tamil (ta), Japanese (ja), Indonesian (id), and Welsh (cy). The 21 translation tasks are divided into high, mid, and low-resource groups, depending on the amount of labeled data available for a translation task. High-resource tasks have more than 100 hours of labeled training data, mid-resource tasks have between 10 and 100 hours, and low-resource have less than ten hours of labeled training data. CoVoST-2 has four high-resource translation tasks corresponding to fr, de, es, and ca source languages and five mid-resource tasks corresponding to it, ru, zh, pt, and fa languages. The rest of the tasks are low-resource. Fig. 3 presents the training data for each of the 21 translation tasks. Notice the data imbalance among different tasks.

In the multilingual translation scenario, we simultaneously train translation models on all 21 tasks mentioned above. We only train translation models on the four high-resource tasks in the zero-shot scenario.

2)  $X \rightarrow Y$  Speech-to-Text Translation: We develop translation models for the 72  $X \rightarrow Y$  translation tasks in the Europarl

benchmark [29]. There are nine spoken languages in Europarl namely, en, fr, de, it, es, pt, pl, ro, and nl. Speech utterances in each spoken language are paired with their corresponding text translations in eight other languages. In the zero-shot scenario, we train the translation models on 32 tasks corresponding to the following four source languages fr, de, es, and it. Each of the four source languages is paired with eight target languages. Table II shows each translation task’s labeled training data.

### C. Translation Models

1) SAMU-XLS-R-300M: We propose SAMU-XLS-R-300M transformer model for translation in this work. The encoder is initialized using the pre-trained SAMU-XLS-R speech encoder (Section IV-A), and the decoder is initialized using the pre-trained MBART text decoder. The suffix 300M in SAMU-XLS-R-300M refers to the model’s size of 300M parameters.

2) XLS-R-(300M, 1B, 2B): We compare SAMU-XLS-R-300M with three XLS-R speech encoder based translation models namely, XLS-R-300M, XLS-R-1B, and XLS-R-2B. The three translation models differ from SAMU-XLS-R-300M model in that the encoder of the translation model is initialized using pre-trained XLS-R speech encoders of different sizes ranging from 300M to 2B parameters. The decoder is initialized using the pre-trained MBART decoder. Unlike our multimodal SAMU-XLS-R speech encoder, XLS-R is only trained using unlabeled speech data. Also, SAMU-XLS-R is specifically trained to learn semantic representations, while XLS-R has no constraints imposed during its training phase to encode semantic knowledge.

3) mSLAM: We compare SAMU-XLS-R-300M translation model against two mSLAM [18] speech encoder based translation models namely, mSLAM-600M, and mSLAM-2B. Like SAMU-XLS-R, mSLAM speech encoder is a multimodal speech-text encoder. Unlike SAMU-XLS-R, which is trained using semantic supervision from a pre-trained semantic text encoder, mSLAM is not trained with explicit semantic supervision.

4) Cascaded Translation: We compare SAMU-XLS-R-300M with a strong cascaded translation system. We perform the translation in two steps: (i) Transcribe the speech utterance using an ASR model, and (ii) Use a text-to-text translation model to translate the ASR transcript to text in a target language. We use whisper-large-v2<sup>4</sup> [50] as the ASR model in the first step and MBART [28] text-to-text translation model for the second step in the cascade. For  $X \rightarrow EN$  cascade, we use MBART-many-to-English text-to-text translation model<sup>5</sup>. The Whisper ASR model is multilingual that supports transcription of around 93 languages. Since [50] shows that whisper achieves state-of-the-art ASR performance on several public benchmarks, we choose Whisper for automatically transcribing speech. MBART-many-to-English translation model can translate text from 50 languages to English.

5) Transcripts: As a topline, we use the ground-truth text transcripts corresponding to speech utterances and use MBART-many-to-English to translate to English.

<sup>4</sup><https://huggingface.co/openai/whisper-large-v2>

<sup>5</sup><https://huggingface.co/facebook/mbart-large-50-many-to-one-mmt>

TABLE III: We compare our proposed SAMU-XLS-R-300M translation model with several other translation models, whose encoders are initialized using differently sized pre-trained XLS-R multilingual unimodal speech encoders. The performance is measured using BLEU-4, Google-BLEU, ROUGE-L, METEOR, BERTScore, and NIST translation metrics.

Model	BLEU-4				Google-BLEU			
	High	Mid	Low	TRFGap	High	Mid	Low	TRFGap
XLS-R-300M	30.6	18.9	5.1	25.1	0.36	0.24	0.10	0.26
XLS-R-1B	34.3	25.5	11.7	22.6	0.38	0.29	0.16	0.22
XLS-R-2B	36.1	27.7	15.1	21.0	0.39	0.31	0.20	0.19
SAMU-XLS-R-300M	34.4	31.1	20.3	14.1	0.38	0.34	0.24	0.13
Cascaded	32.6	29.7	22.5	10.1	0.36	0.33	0.26	0.10
Transcripts	36.4	34.2	27.9	8.5	0.39	0.37	0.32	0.08

Model	ROUGE-L				METEOR			
	High	Mid	Low	TRFGap	High	Mid	Low	TRFGap
XLS-R-300M	0.60	0.44	0.23	0.37	0.62	0.45	0.24	0.38
XLS-R-1B	0.61	0.49	0.31	0.30	0.63	0.50	0.32	0.31
XLS-R-2B	0.63	0.53	0.38	0.25	0.65	0.53	0.39	0.26
SAMU-XLS-R-300M	0.62	0.58	0.42	0.19	0.64	0.59	0.45	0.19
Cascaded	0.60	0.56	0.45	0.14	0.61	0.56	0.46	0.15
Transcripts	0.64	0.61	0.52	0.11	0.66	0.62	0.54	0.12

Model	BERTScore				NIST			
	High	Mid	Low	TRFGap	High	Mid	Low	TRFGap
XLS-R-300M	0.56	0.33	0.04	0.52	8.0	5.0	1.9	6.1
XLS-R-1B	0.58	0.41	0.16	0.42	8.3	5.9	3.0	5.3
XLS-R-2B	0.61	0.45	0.25	0.36	8.6	6.3	3.7	4.9
SAMU-XLS-R-300M	0.59	0.54	0.34	0.25	8.3	7.1	4.4	4.0
Cascaded	0.56	0.50	0.37	0.20	8.2	6.9	4.9	3.3
Transcripts	0.62	0.58	0.47	0.14	8.7	7.7	5.7	3.0

TABLE IV: We compare our proposed SAMU-XLS-R-300M translation model with mSLAM translation models, whose encoders are initialized using differently sized pre-trained mSLAM multilingual multimodal speech encoders. The performance is measured using the BLEU-4 translation metric.

Model	BLEU-4			
	High	Mid	Low	TRFGap
mSLAM-600M	37.6	27.8	15.1	22.5
mSLAM-2B	37.8	29.6	18.5	19.3
SAMU-XLS-R-300M	34.4	31.1	20.3	14.1

## VI. RESULTS

### A. Multilingual $X \rightarrow EN$ Translation

**Table III** shows the performance of different translation models on the high, mid, and low-resource translation groups in the CoVoST-2 speech-to-text translation benchmark. We compare our proposed SAMU-XLS-R-300M translation model against XLS-R-300M, XLS-R-1B, and XLS-R-2B translation models. CoVoST-2 comprises 21  $X \rightarrow EN$  translation tasks, and the translation models are trained simultaneously on all translation tasks. See Section V-B for details about the trans-

lation tasks, and Section V-C for details about the different translation models.

The model performance is measured using the standard translation metrics, namely BLEU-4 [51], Google-BLEU [52], ROUGE-L [53], METEOR [54], BERTScore [55], and NIST [56]. We make the following **observations**: (i) On **High resource tasks**, the XLS-R-2B model performs the best, with SAMU-XLS-R-300M lagging a couple of points behind. Compared to the similar-sized XLS-R-300M model, SAMU-XLS-R-300M performs 4 BLEU points better. (ii) On **Mid resource tasks**, SAMU-XLS-R-300M outperforms all the models achieving a BLEU score of 31.1, which is significantly better than XLS-R-300M model’s BLEU score of 5.1. SAMU-XLS-R-300M even outperforms the much larger XLS-R-2B speech encoder by 3.3 BLEU points. (iii) On **Low resource tasks**, SAMU-XLS-R-300M performs the best. Compared to the similar-sized XLS-R-300M model, SAMU-XLS-R-300M does better by 15 BLEU points. It also outperforms the much larger XLS-R-2B by 5.2 BLEU points. The cross-lingual transfer gap (TRFGap), which is the difference in performance between high and low resource task groups, is significantly less (14.1 BLEU) for SAMU-XLS-R-300M model compared to other models. Second to SAMU-XLS-R-300M is XLS-R-2B, which has a TRFGap of 21 BLEU points while having 500% more parameters. Similar arguments can be made using metrics other than BLEU-4.



TABLE V: We compare our proposed SAMU-XLS-R-300M translation model with several other translation models, whose encoders are initialized using differently sized pre-trained XLS-R multilingual unimodal speech encoders. The performance is measured using the BLEU-4 translation metric.

Model	fr	de	es	ca	it	fa	ru	zh	pt
XLS-R-300M	34.9	29.3	35.9	30.6	30.9	6.3	30.0	5.2	30.8
XLS-R-1B	36.3	31.4	37.8	32.1	33.5	9.1	35.7	6.9	41.4
XLS-R-2B	37.6	33.6	39.1	33.9	35.0	13.0	39.5	9.4	41.8
SAMU-XLS-R-300M	36.1	31.7	37.9	31.9	34.0	22.0	42.1	13.1	44.2
Cascaded	32.7	30.9	36.4	30.3	32.5	14.3	42.9	14.4	44.2
Transcripts	38.4	34.1	41.1	32.1	36.4	24.2	46.0	17.4	46.9
Model	nl	tr	et	mn	ar	sv	lv	sl	ta
XLS-R-300M	25.1	6.7	4.0	0.2	3.9	11.3	7.4	8.3	0.0
XLS-R-1B	29.6	11.1	8.0	0.6	9.3	24.5	15.7	16.8	0.1
XLS-R-2B	31.6	16.9	11.2	1.5	17.1	29.7	19.7	19.0	0.5
SAMU-XLS-R-300M	34.9	28.4	11.6	3.4	36.6	28.5	1.9	12.9	4.0
Cascaded	33.0	25.1	17.4	0.0	35.7	39.6	20.3	27.8	1.6
Transcripts	36.3	28.8	25.6	3.8	44.6	46.4	29.2	38.4	2.2
Model	cy	ja	id						
XLS-R-300M	2.8	0.6	1.2						
XLS-R-1B	6.61	1.3	7.8						
XLS-R-2B	14.2	3.5	16.4						
SAMU-XLS-R-300M	34.1	13.1	34.4						
Cascaded	6.4	19.4	43.6						
Transcripts	9.0	20.8	49.8						

On all metrics, SAMU-XLS-R is significantly better than the XLS-R baselines and comparable to the strong cascaded system, while significantly worse than the model which uses the human transcripts corresponding to speech utterances for translation into English using the MBART-many-to-English text translation model. For the subsequent experiments, we only report BLEU-4 scores.

**Table IV** compares SAMU-XLS-R-300M translation model with mSLAM-600M, and mSLAM-2B models that use differently sized pre-trained multimodal (speech-text) multilingual mSLAM speech encoder. SAMU-XLS-R-300M performs better on mid- and low-resource translation tasks. Importantly, SAMU-XLS-R-300M has a lower cross-lingual transfer gap (TRFGap) between high and low resource groups of 14.1 BLEU points compared to 22.5 for mSLAM-600M, and 19.3 for mSLAM-2B. The BLEU scores for mSLAM models are lifted from [18]. Since mSLAM [18] report only BLEU scores on the CoVoST-2 benchmark, and we do not have access to mSLAM models, we can not evaluate the model using metrics other than BLEU-4.

The above observations validate our claims that building translation technology on top of semantic speech representations would increase the cross-lingual task knowledge transfer from high to low-resource languages. Similar inferences can be reached by using metrics other than BLEU-4.

**Table V** shows the performance of different translation models on each of the 21  $X \rightarrow EN$  speech-to-text translation tasks in the CoVoST-2 benchmark. We observe that SAMU-XLS-R-300M significantly outperforms the similarly sized XLS-R-300M translation model on several mid and low-

resource languages. Some notable improvements are for the following source languages: id (34.4 vs. 1.2 BLEU), cy (34.1 vs. 2.8 BLEU), ja (13.1 vs 0.6 BLEU), sv (28.5 vs 11.3 BLEU), tr (28.4 vs 6.7 BLEU), ar (36.6 vs. 3.9 BLEU), fa (22.0 vs. 6.3 BLEU), and pt (44.2 vs. 30.8 BLEU). For some source languages SAMU-XLS-R-300M does not do well, such as lv (1.9 BLEU), sl (12.9 BLEU), mn (3.4 BLEU), et (11.6 BLEU), ta (4.0), ja (13.1 BLEU), and zh (13.1 BLEU). For ta, ja, mn, and zh, the topline (Transcripts) model also performs poorly. For sl, and lv, the topline text-to-text translation and cascaded models perform significantly better than the SAMU-XLS-R-300M model.

Poor performance of SAMU-XLS-R-300M on lv, mn, and sl can be explained by the lack of available transcribed speech data in these languages for multimodal pre-training of SAMU-XLS-R (Section IV-A). We have 7 hours for lv, 12 hours for mn, and 9 hours of transcribed speech for sl, compared to 317 hours for fa, 85 hours for ar, 116 hours for cy, 98 hours for nl, 40 hours for sv, 25.8 hours for id, 162 hours for ru, 400 hours for es, and close to 1K hours for fr, de, and ca. However, for ta, zh, and ja we have a decent amount of transcribed speech, but still, the performance is relatively poor. This can be explained away by observing the performance of the topline (Transcripts), where we use a pre-trained MBART-many-to-English text-to-text translation model (Details in Section V-C) that translates the ground-truth transcripts corresponding to speech utterances in language X to text in English. The topline performance for zh, ja, and ta is relatively poor. Since we use the decoder of MBART-many-to-English



model to initialize the decoder of our speech-to-text translation model SAMU-XLS-R-300M, we also observe poor speech-text-translation performance on these tasks.

### B. Zero-Shot $X \rightarrow EN$ Speech-to-Text Translation.

Next, we train the translation models on four high-resource  $X \rightarrow EN$  translation tasks in the CoVoST-2 benchmark (See Section V-B for details). We evaluate the  $X \rightarrow EN$  translation models on the high, mid, and low task groups to test for zero-shot cross-lingual transfer capability of SAMU-XLS-R-300M from high to mid and low-resource  $X \rightarrow EN$  tasks. We compare SAMU-XLS-R-300 with XLS-R-300M translation model. Figure 4 presents the results. We observe that SAMU-XLS-R-300M performs on average 18.8 BLEU points better in the mid-resource and 11.9 BLEU points in the low-resource group. The cross-lingual transfer gap between the high & mid and high & low groups is significantly smaller for SAMU-XLS-R-300M (9.0, and 20.8) than XLS-R-300M (25.2, and 30.1).

Fig. 4: We report average BLEU-4 for the zero-shot  $X \rightarrow EN$  multilingual speech-to-text translation scenario on the high, mid, and low resource task groups in the CoVoST-2 benchmark. We compare our translation model SAMU-XLS-R-300M with the similarly sized XLS-R-300M translation model. The translation models are only trained on high-resource groups, while the mid and low-resource groups are *unseen* during training.

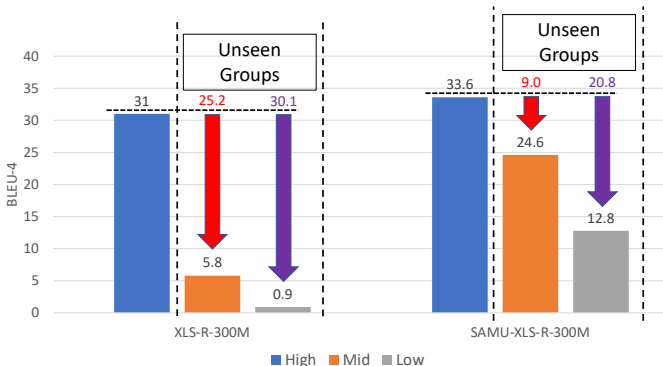

These results strengthen our claims that building speech translation technology with semantic speech representations would improve cross-lingual transfer across languages. Note that zero-shot implies that the translation model during its training does not see any paired  $X \rightarrow EN$  translation data for mid and low-resource languages  $X$ . Transcribed speech data was available for these languages during multimodal pre-training of SAMU-XLS-R speech encoder which is used to initialize the encoder of the SAMU-XLS-R-300M translation model.

### C. Zero-Shot $X \rightarrow Y$ Speech-to-Text Translation.

Finally, to further bolster our claims about the usefulness of semantic speech representations for translation, we compare translation models on the 72  $X \rightarrow Y$  translation tasks in the Europarl Benchmark. See Section V-B for details about translation tasks and available data for training translation models.

We train translation models SAMU-XLS-R-300M and XLS-R-300M on a 32-task subset out of 72 tasks. The 32 tasks correspond to four source spoken languages: fr, de, es, and it, while the remaining 40 tasks correspond to five source languages: pl, pt, ro, nl, and en. Speech utterances in each source language are paired with text translations in eight other languages. Unlike  $X \rightarrow EN$  translation models discussed above, we initialize the decoder of  $X \rightarrow Y$  translation models with the decoder of MBART-many-to-many<sup>6</sup> model instead of MBART-many-to-English, since we have to generate translations in multiple target languages.

Figure 5 compares the performance of XLS-R-300M, and SAMU-XLS-R-300M on the 72 translation tasks. We report the absolute BLEU-4 score improvement that SAMU-XLS-R-300M achieves over XLS-R-300M baseline translation model. The darker the cell in the figure, the greater the improvement in the BLEU score. We observe that SAMU-XLS-R-300M performs drastically better than XLS-R-300M on the 40 unseen (during translation model training) translation tasks and at par on the 32 seen (during translation model training) translation tasks. We observe the biggest improvements in unseen tasks such as pl $\rightarrow$ en (23.8), ro $\rightarrow$ en (21.9), pl $\rightarrow$ en (19.9), pl $\rightarrow$ fr (19.6), ro $\rightarrow$ es (17.2), etc. Overall, SAMU-XLS-R-300M improves over XLS-R-300M baseline model by an average of 12 BLEU-4 points.

TABLE VI: We compare the translation model’s performance when using Adapter-based fine-tuning vs. fine-tuning all the encoder parameters. The performance is measured using the **BLEU-4** translation metric.

Model	fr	de	es	it	pl	pt	ro	nl
XLS-R-F	33.0	25.4	29.4	30.3	2.4	12.7	7.6	5.2
XLS-R-A	29.8	22.4	25.5	27.2	3.2	15.6	9.1	8.2
SAMU-XLS-R-F	33.2	26.3	29.7	30.7	3.0	12.2	9.8	7.0
SAMU-XLS-R-A	32.3	25.5	29.3	28.7	24.3	18.4	29.9	24.1

### D. Analysis

1) XLS-R vs. XLS-R-CTC: The experiments above compare SAMU-XLS-R with XLS-R multilingual speech encoder. XLS-R is trained using multilingual unlabeled speech data in 128 languages via self-supervised learning, while SAMU-XLS-R fine-tunes pre-trained XLS-R using multilingual transcribed speech data via semantic knowledge distillation. But, what if instead of fine-tuning pre-trained XLS-R with semantic supervision from text transcriptions like SAMU-XLS-R does, we fine-tune XLS-R on the task of Automatic Speech Recognition using the same multilingual transcribed speech data that was used for SAMU-XLS-R training? We compare the translation performance of XLS-R and XLS-R-CTC encoders in Fig. 6. XLS-R-CTC refers to the encoder we get after supervised CTC-based fine-tuning of pre-trained XLS-R using multilingual transcribed speech data. CTC [57] is a standard framework for training ASR models *end-to-end*. We observe that the pre-trained XLS-R encoder performs better than XLS-R-CTC encoder. XLS-R-CTC

<sup>6</sup><https://huggingface.co/facebook/mbart-large-50-many-to-many-mmt>

Fig. 5: Absolute BLEU score improvements using SAMU-XLS-R-300M over XLS-R-300M baseline on the 72  $X \rightarrow Y$  translation tasks in the Europarl benchmark. The translation models are trained on a subset of 32 translation tasks, corresponding to four source languages, while 40 tasks are unseen during training corresponding to five source languages.

	SRC/TGT	FR	DE	ES	IT	PL	PT	RO	NL	EN
Training Data	FR	NA	0.8	0	-0.4	-0.1	-1.5	0.7	-0.1	1.2
	DE	2.3	NA	1.5	1.3	1	0.9	1.6	-0.1	2
	ES	0.9	0.8	NA	0.3	1.7	0.3	1.4	1	2.9
	IT	-0.8	-0.1	0.1	NA	-0.8	-1.6	0.4	-0.4	1.3
Unseen During Training	PL	19.6	13.7	19.9	14.5	NA	16.1	16.1	15.5	23.8
	PT	1.4	1.1	1.6	0.3	0.5	NA	1.9	0.4	2
	RO	18.4	11.5	17.2	13.7	11.2	14.8	NA	12.7	21.9
	NL	11.5	9.5	8.9	9	7.4	10.9	10.1	NA	13.3
	EN	17.7	13.5	19.6	14.1	9.7	16.6	17.5	13.9	NA

Fig. 6: We compare on the Europarl  $X \rightarrow EN$  benchmark XLS-R and XLS-R-CTC initialization of the translation model’s encoder. XLS-R is pre-trained using unlabeled speech via self-supervised learning, while XLS-R-CTC refers to the XLS-R encoder that is fine-tuned (after self-supervised pre-training) using transcribed speech data. We report the BLEU-4 score for eight source spoken languages. Speech utterances in each source language are paired with its English text translations.

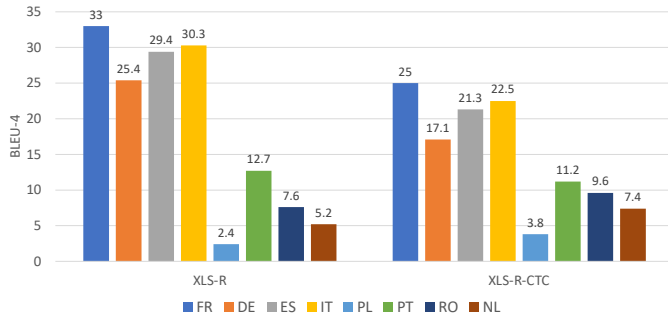

encoder is slightly better on some translation tasks. Still, the difference is so small that our previous observations on the efficacy of our proposed semantic speech encoder SAMU-XLS-R are not impacted, even though we compared SAMU-XLS-R with the XLS-R encoder, which is trained using unlabeled multilingual speech.

2) *Adapter vs. Full Encoder Fine-Tuning*: As mentioned in Section IV-B3, we perform Adapter-based fine-tuning of the translation model’s encoder, where we insert new task-specific parameters in the form of adapters in each encoder layer. We only fine-tune adapter layers while keeping the rest of the layers frozen to their pre-trained values. Table VI compares the translation model’s performance when using Adapter-based fine-tuning vs. fine-tuning all the encoder parameters. We observe that using adapter fine-tuning with XLS-R-300M (XLS-R-A) translation model brings performance gains on low-resource tasks such as  $ro \rightarrow en$ ,  $nl \rightarrow en$ ,  $pt \rightarrow en$ , and  $pl \rightarrow en$ . In contrast, the performance degrades significantly for higher-resource tasks compared to full encoder fine-tuning (XLS-R-F). We observe a similar trend with SAMU-XLS-R-300M translation model. But, the performance gains for low-resource tasks are drastic with adapter-based fine-tuning of the encoder

(SAMU-XLS-R-A). Again, this is due to our proposed *semantic* speech encoder SAMU-XLS-R, which results in a significant cross-lingual transfer from high to low-resource translation tasks. This result also shows that preserving semantic knowledge during training for downstream translation tasks, learned by the SAMU-XLS-R encoder as a result of our multimodal learning framework, is essential.

## VII. CONCLUSION

This paper addresses the central question of cross-lingual transfer learning in Natural Language Processing. We focus on the problem of multilingual spoken language translation, which we model using the standard encoder-decoder model. We analyze the impact of different encoder initializations on the downstream translation task performance. We show that by initializing the encoder with an encoder that we pre-train using the newly introduced *semantic knowledge distillation framework* SAMU-XLS-R, we achieve significantly better cross-lingual transfer in the downstream speech-to-text translation task than the baselines. The baseline translation models use the state-of-the-art multilingual pre-trained speech encoder XLS-R and others for initialization.

To substantiate our claims, we perform multilingual translation on two public benchmarks, CoVoST-2 and Europarl. On the 21  $X \rightarrow$ English CoVoST-2 speech translation tasks, we achieve an average improvement of 12.8 BLEU points. In the zero-shot scenario, where we train the translation model only on the four high-resource languages while keeping the rest 17 languages unseen (during training), we achieve an average improvement of 11.8 BLEU points over the baseline XLS-R encoder initialization. In particular, we achieve drastic improvements of 18.8 and 11.9 average BLEU points on medium and low-resource languages, respectively. We made similar observations on the Europarl  $X \rightarrow Y$  speech-to-text translation benchmark.

Our work has limitations. Currently, training SAMU-XLS-R requires access to multilingual transcribed data, which could be hard for many spoken languages. Also, the dependence on a pre-trained text encoder hinders expanding SAMU-XLS-R to more languages. Hence, future work should focus on injecting semantic information via *weakly supervised learning* using unaligned speech and text data and without using the LaBSE text encoder.

## REFERENCES

- [1] D. Harwath, A. Torralba, and J. Glass, “Unsupervised learning of spoken language with visual context,” *Advances in Neural Information Processing Systems*, vol. 29, 2016.
- [2] W.-N. Hsu, Y. Zhang, and J. Glass, “Unsupervised learning of disentangled and interpretable representations from sequential data,” *Advances in neural information processing systems*, vol. 30, 2017.
- [3] S. Khurana, S. R. Joty, A. Ali, and J. Glass, “A factorial deep markov model for unsupervised disentangled representation learning from speech,” in *ICASSP 2019 - 2019 IEEE International Conference on Acoustics, Speech and Signal Processing (ICASSP)*, 2019, pp. 6540–6544.
- [4] S. Pascual, M. Ravanelli, J. Serrà, A. Bonafonte, and Y. Bengio, “Learning problem-agnostic speech representations from multiple self-supervised tasks,” *arXiv:1904.03416*, 2019.
- [5] S. Schneider, A. Baevski, R. Collobert, and M. Auli, “wav2vec: Unsupervised pre-training for speech recognition,” *arXiv:1904.05862*, 2019. [Online]. Available: <https://arxiv.org/abs/1904.05862>
- [6] A. Baevski, S. Schneider, and M. Auli, “vq-wav2vec: Self-supervised learning of discrete speech representations,” in *International Conference on Learning Representations*, 2020. [Online]. Available: <https://openreview.net/forum?id=rylwJxrYDS>
- [7] Y.-A. Chung and J. Glass, “Generative pre-training for speech with autoregressive predictive coding,” in *ICASSP 2020-2020 IEEE International Conference on Acoustics, Speech and Signal Processing (ICASSP)*. IEEE, 2020, pp. 3497–3501.
- [8] S. Khurana, A. Laurent, W.-N. Hsu, J. Chorowski, A. Lancucki, R. Marxer, and J. Glass, “A convolutional deep markov model for unsupervised speech representation learning,” *arXiv:2006.02547*, 2020. [Online]. Available: <https://arxiv.org/abs/2006.02547>
- [9] A. Baevski, H. Zhou, A. Mohamed, and M. Auli, “wav2vec 2.0: A framework for self-supervised learning of speech representations,” *arXiv:2006.11477*, 2020.
- [10] D. Harwath, W.-N. Hsu, and J. Glass, “Learning hierarchical discrete linguistic units from visually-grounded speech,” in *International Conference on Learning Representations*, 2020. [Online]. Available: <https://openreview.net/forum?id=B1e1Cp4KwH>
- [11] A. Conneau, A. Baevski, R. Collobert, A. Mohamed, and M. Auli, “Unsupervised cross-lingual representation learning for speech recognition,” *arXiv:2006.13979*, 2020. [Online]. Available: <https://arxiv.org/abs/2006.13979>
- [12] A. T. Liu, S.-W. Li, and H. yi Lee, “TERA: Self-supervised learning of transformer encoder representation for speech,” *IEEE/ACM Transactions on Audio, Speech, and Language Processing*, vol. 29, pp. 2351–2366, 2021. [Online]. Available: <https://doi.org/10.1109/taslp.2021.3095662>
- [13] W.-N. Hsu, B. Bolte, Y.-H. H. Tsai, K. Lakhota, R. Salakhutdinov, and A. Mohamed, “Hubert: Self-supervised speech representation learning by masked prediction of hidden units,” *IEEE/ACM Transactions on Audio, Speech, and Language Processing*, vol. 29, pp. 3451–3460, 2021.
- [14] Y.-A. Chung, Y. Zhang, W. Han, C.-C. Chiu, J. Qin, R. Pang, and Y. Wu, “W2v-bert: Combining contrastive learning and masked language modeling for self-supervised speech pre-training,” *arXiv:2108.06209*, 2021. [Online]. Available: <https://arxiv.org/abs/2108.06209>
- [15] A. Babu, C. Wang, A. Tjandra, K. Lakhota, Q. Xu, N. Goyal, K. Singh, P. von Platen, Y. Saraf, J. Pino, A. Baevski, A. Conneau, and M. Auli, “Xls-r: Self-supervised cross-lingual speech representation learning at scale,” *arXiv:2111.09296*, 2021. [Online]. Available: <https://arxiv.org/abs/2111.09296>
- [16] A. H. Liu, S. Jin, C.-I. J. Lai, A. Rouditchenko, A. Oliva, and J. Glass, “Cross-modal discrete representation learning,” *arXiv:2106.05438*, 2021. [Online]. Available: <https://arxiv.org/abs/2106.05438>
- [17] S. Khurana, A. Laurent, and J. Glass, “Samu-xls: Semantically-aligned multimodal utterance-level cross-lingual speech representation,” *IEEE Journal of Selected Topics in Signal Processing*, pp. 1–13, 2022.
- [18] A. Bapna, C. Cherry, Y. Zhang, Y. Jia, M. Johnson, Y. Cheng, S. Khanuja, J. Riesa, and A. Conneau, “mSLAM: Massively multilingual joint pre-training for speech and text,” *arXiv:2202.01374*, 2022. [Online]. Available: <https://arxiv.org/abs/2202.01374>
- [19] A. v. d. Oord, Y. Li, and O. Vinyals, “Representation learning with contrastive predictive coding,” *arXiv:1807.03748*, 2018. [Online]. Available: <https://arxiv.org/abs/1807.03748>
- [20] M. Gutmann and A. Hyvärinen, “Noise-contrastive estimation: A new estimation principle for unnormalized statistical models,” in *Proceedings of the Thirteenth International Conference on Artificial Intelligence and Statistics*, ser. Proceedings of Machine Learning Research, Y. W. Teh and M. Titterton, Eds., vol. 9. Chia Laguna Resort, Sardinia, Italy: PMLR, 13–15 May 2010, pp. 297–304. [Online]. Available: <https://proceedings.mlr.press/v9/gutmann10a.html>
- [21] R. Bommasani and et. al., “On the opportunities and risks of foundation models,” *arXiv:2108.07258*, 2021. [Online]. Available: <https://arxiv.org/abs/2108.07258>
- [22] M. Rivière, A. Joulin, P.-E. Mazaré, and E. Dupoux, “Unsupervised pretraining transfers well across languages,” *arXiv:2002.02848*, 2020.
- [23] X. Li, C. Wang, Y. Tang, C. Tran, Y. Tang, J. Pino, A. Baevski, A. Conneau, and M. Auli, “Multilingual speech translation with efficient finetuning of pretrained models,” *arXiv:2010.12829*, 2020. [Online]. Available: <https://arxiv.org/abs/2010.12829>
- [24] J. Shor, A. Jansen, W. Han, D. Park, and Y. Zhang, “Universal paralinguistic speech representations using self-supervised conformers,” *arXiv:2110.04621*, 2021. [Online]. Available: <https://arxiv.org/abs/2110.04621>
- [25] S. wen Yang, P.-H. Chi, Y.-S. Chuang, C.-I. J. Lai, K. Lakhota, Y. Y. Lin, A. T. Liu, J. Shi, X. Chang, G.-T. Lin, T.-H. Huang, W.-C. Tseng, K. tik Lee, D.-R. Liu, Z. Huang, S. Dong, S.-W. Li, S. Watanabe, A. Mohamed, and H. yi Lee, “Superb: Speech processing universal performance benchmark,” *arXiv:2105.01051*, 2021.
- [26] I. Sutskever, O. Vinyals, and Q. V. Le, “Sequence to sequence learning with neural networks,” *arXiv:1409.3215*, 2014. [Online]. Available: <https://arxiv.org/abs/1409.3215>
- [27] A. Vaswani, N. Shazeer, N. Parmar, J. Uszkoreit, L. Jones, A. N. Gomez, L. Kaiser, and I. Polosukhin, “Attention is all you need,” *arXiv:1706.03762*, 2017. [Online]. Available: <https://arxiv.org/abs/1706.03762>
- [28] Y. Liu, J. Gu, N. Goyal, X. Li, S. Edunov, M. Ghazvininejad, M. Lewis, and L. Zettlemoyer, “Multilingual denoising pre-training for neural machine translation,” *Transactions of the Association for Computational Linguistics*, vol. 8, pp. 726–742, 2020. [Online]. Available: <https://aclanthology.org/2020.tacl-1.47>
- [29] J. Iranzo-Sánchez, J. A. Silvestre-Cerdà, J. Jorge, N. Roselló, A. Giménez, A. Sanchis, J. Civera, and A. Juan, “Europarl-st: A multilingual corpus for speech translation of parliamentary debates,” *arXiv:1911.03167*, 2019. [Online]. Available: <https://arxiv.org/abs/1911.03167>
- [30] C. Wang, J. Pino, A. Wu, and J. Gu, “Covost: A diverse multilingual speech-to-text translation corpus,” *arXiv:2002.01320*, 2020. [Online]. Available: <https://arxiv.org/abs/2002.01320>
- [31] G. Laperrière, V. Pelloin, M. Rouvier, T. Stafylakis, and Y. Estève, “On the use of semantically-aligned speech representations for spoken language understanding,” *arXiv:2210.05291*, 2022. [Online]. Available: <https://arxiv.org/abs/2210.05291>
- [32] F. Feng, Y. Yang, D. Cer, N. Arivazhagan, and W. Wang, “Language-agnostic bert sentence embedding,” *arXiv:2007.01852*, 2020. [Online]. Available: <https://arxiv.org/abs/2007.01852>
- [33] Y. Lecun, L. Bottou, Y. Bengio, and P. Haffner, “Gradient-based learning applied to document recognition,” *Proceedings of the IEEE*, vol. 86, no. 11, pp. 2278–2324, 1998.
- [34] D. Hendrycks and K. Gimpel, “Gaussian error linear units (gelus),” *arXiv:1606.08415*, 2016. [Online]. Available: <https://arxiv.org/abs/1606.08415>
- [35] A. F. Agarap, “Deep learning using rectified linear units (ReLU),” *arXiv:1803.08375*, 2018. [Online]. Available: <https://arxiv.org/abs/1803.08375>
- [36] C. Wang, M. Riviere, A. Lee, A. Wu, C. Talnikar, D. Haziza, M. Williamson, J. Pino, and E. Dupoux, “VoxPopuli: A large-scale multilingual speech corpus for representation learning, semi-supervised learning and interpretation,” in *Proceedings of the 59th Annual Meeting of the Association for Computational Linguistics and the 11th International Joint Conference on Natural Language Processing (Volume 1: Long Papers)*. Online: Association for Computational Linguistics, Aug. 2021, pp. 993–1003. [Online]. Available: <https://aclanthology.org/2021.acl-long.80>
- [37] R. Ardila, M. Branson, K. Davis, M. Henretty, M. Kohler, J. Meyer, R. Morais, L. Saunders, F. M. Tyers, and G. Weber, “Common Voice: A massively-multilingual speech corpus,” *arXiv:1912.06670*, 2020.
- [38] V. Pratap, Q. Xu, A. Sriram, G. Synnaeve, and R. Collobert, “Mls: A large-scale multilingual dataset for speech research,” *arXiv:2012.03411*, 2020.
- [39] J. Valk and T. Alumäe, “Voxlingua107: a dataset for spoken language recognition,” *arXiv:2011.12998*, 2020. [Online]. Available: <https://arxiv.org/abs/2011.12998>
- [40] P. Safari, M. India, and J. Hernando, “Self-attention encoding and pooling for speaker recognition,” *arXiv:2008.01077*, 2020.

- [41] T. Ko, V. Peddinti, D. Povey, and S. Khudanpur, "Audio augmentation for speech recognition," in *Proc. Interspeech 2015*, 2015, pp. 3586–3589.
- [42] C. Szegedy, V. Vanhoucke, S. Ioffe, J. Shlens, and Z. Wojna, "Rethinking the inception architecture for computer vision," in *2016 IEEE Conference on Computer Vision and Pattern Recognition (CVPR)*, 2016, pp. 2818–2826.
- [43] R. Müller, S. Kornblith, and G. Hinton, "When does label smoothing help?" *arXiv:1906.02629*, 2019. [Online]. Available: <https://arxiv.org/abs/1906.02629>
- [44] D. P. Kingma and J. Ba, "Adam: A method for stochastic optimization," *arXiv:1412.6980*, 2014. [Online]. Available: <https://arxiv.org/abs/1412.6980>
- [45] P. Micikevicius, S. Narang, J. Alben, G. Diamos, E. Elsen, D. Garcia, B. Ginsburg, M. Houston, O. Kuchaiev, G. Venkatesh, and H. Wu, "Mixed precision training," *arXiv:1710.03740*, 2017. [Online]. Available: <https://arxiv.org/abs/1710.03740>
- [46] M. Ott, S. Edunov, A. Baevski, A. Fan, S. Gross, N. Ng, D. Grangier, and M. Auli, "fairseq: A fast, extensible toolkit for sequence modeling," *arXiv:1904.01038*, 2019. [Online]. Available: <https://arxiv.org/abs/1904.01038>
- [47] D. S. Park, W. Chan, Y. Zhang, C.-C. Chiu, B. Zoph, E. D. Cubuk, and Q. V. Le, "SpecAugment: A simple data augmentation method for automatic speech recognition," *arXiv:1904.08779*, 2019.
- [48] N. Houlsby, A. Giurgiu, S. Jastrzebski, B. Morrone, Q. de Laroussilhe, A. Gesmundo, M. Attariyan, and S. Gelly, "Parameter-efficient transfer learning for nlp," in *Proc. ICML*, 2019.
- [49] J. L. Ba, J. R. Kiros, and G. E. Hinton, "Layer normalization," *arXiv:1607.06450*, 2016.
- [50] A. Radford, J. W. Kim, T. Xu, G. Brockman, C. McLeavey, and I. Sutskever, "Robust speech recognition via large-scale weak supervision."
- [51] M. Post, "A call for clarity in reporting BLEU scores," in *Proceedings of the Third Conference on Machine Translation: Research Papers*. Belgium, Brussels: Association for Computational Linguistics, Oct. 2018, pp. 186–191. [Online]. Available: <https://www.aclweb.org/anthology/W18-6319>
- [52] Y. Wu, M. Schuster, Z. Chen, Q. V. Le, M. Norouzi, W. Macherey, M. Krikun, Y. Cao, Q. Gao, K. Macherey, J. Klingner, A. Shah, M. Johnson, X. Liu, Łukasz Kaiser, S. Gouws, Y. Kato, T. Kudo, H. Kazawa, K. Stevens, G. Kurian, N. Patil, W. Wang, C. Young, J. Smith, J. Riesa, A. Rudnick, O. Vinyals, G. Corrado, M. Hughes, and J. Dean, "Google's neural machine translation system: Bridging the gap between human and machine translation," 2016.
- [53] C.-Y. Lin, "ROUGE: A package for automatic evaluation of summaries," in *Text Summarization Branches Out*. Barcelona, Spain: Association for Computational Linguistics, Jul. 2004, pp. 74–81. [Online]. Available: <https://aclanthology.org/W04-1013>
- [54] S. Banerjee and A. Lavie, "METEOR: An automatic metric for MT evaluation with improved correlation with human judgments," in *Proceedings of the ACL Workshop on Intrinsic and Extrinsic Evaluation Measures for Machine Translation and/or Summarization*. Ann Arbor, Michigan: Association for Computational Linguistics, Jun. 2005, pp. 65–72. [Online]. Available: <https://www.aclweb.org/anthology/W05-0909>
- [55] M. K. Eddine, G. Shang, A. J.-P. Tixier, and M. Vazirgiannis, "Fragalscore: Learning cheaper, lighter and faster evaluation metrics for automatic text generation," *arXiv preprint arXiv:2110.08559*, 2021.
- [56] G. Doddington, "Automatic evaluation of machine translation quality using n-gram co-occurrence statistics," in *Proceedings of the Second International Conference on Human Language Technology Research*, ser. HLT '02. San Francisco, CA, USA: Morgan Kaufmann Publishers Inc., 2002, p. 138–145.
- [57] A. Graves, S. Fernández, F. J. Gomez, and J. Schmidhuber, "Connectionist temporal classification: Labelling unsegmented sequence data with recurrent neural networks," in *Proc. ICML*, Jun. 2006.