

ONCache: A Cache-Based Low-Overhead Container Overlay Network

Shengkai Lin¹, Shizhen Zhao¹, Peirui Cao¹, Xinchu Han¹,
 Quan Tian², Wenfeng Liu², Qi Wu², Donghai Han², Xinbing Wang¹, and Chenghu Zhou^{1,3}
¹Shanghai Jiao Tong University, ²VMware, ³Chinese Academy of Sciences

Abstract

Recent years have witnessed a widespread adoption of containers. While containers simplify and accelerate application development, existing container network technologies either incur significant overhead, which hurts performance for distributed applications, or lose flexibility or compatibility, which hinders the widespread deployment in production.

We design and implement ONCache (**O**verlay **N**etwork **C**ache), a cache-based container overlay network, to eliminate the overhead while keeping flexibility and compatibility. We carefully analyze the difference between an overlay network and a host network, and find that an overlay network incurs extra packet processing, including encapsulating, intra-host routing, namespace traversing and packet filtering. Fortunately, the extra processing exhibits an *invariance property*, e.g., most packets of the same flow have the same processing results. This property motivates us to cache the extra processing results. With the proposed cache, ONCache significantly reduces the extra overhead while maintaining the same flexibility and compatibility as standard overlay networks. We implement ONCache using eBPF with only 524 lines of code, and deploy ONCache as a plugin of Antrea.

With ONCache, container communication achieves similar performance as host communication. Compared to the standard overlay network, ONCache improves the throughput and request-response transaction rate by 12% and 36% for TCP (20% and 34% for UDP), while significantly reduces per-packet CPU overhead. Many distributed applications also benefit from ONCache.

1 Introduction

Containers [7, 13] are becoming increasingly popular for large-scale distributed application deployment because they are flexible and lightweight. By bundling an application along with all its dependencies and configuration files into one container image, containers bring forth the ability to *build once and run anywhere*. In addition, containers share the host OS

Technology	Performance	Flexibility	Compatibility
Host	✓	✗	✓
Bridge	✓	✗	✓
Macvlan	✓	✗	✓
IPvlan	✓	✗	✓
SR-IOV	✓	✗	✓
Overlay	✗	✓	✓
Falcon [26]	✗	✓	✓
Slim [54]	✓	✓	✗
ONCache	✓	✓	✓

Table 1: Compare container networking technologies.

kernel rather than simulating an entire OS, and thus are more lightweight than virtual machines. Container orchestration tools like Kubernetes [24], Docker Swarm [14], etc., further reduce the container management complexity, by enabling auto-deployment, auto-scaling, auto-high-availability, etc [6].

The container network is a key for containers to communicate with each other and hold distributed applications. We usually expect the container network can provide low-overhead, high-performance network while keeping the flexibility and compatibility. However, none of the existing container networks can meet all these expectations (listed in Table 1).

Hurt flexibility. Containers in the host network share the host IP and must coordinate the ports on a host, which hurts deployment flexibility. Bridge network or device virtualization techniques (Macvlan/IPvlan/SR-IOV) allow setting containers' own IPs and container packets are directly forwarded to the underlay network. These networks requires either all hosts in the same L2 network or the underlay network can route container packets. Either requirement imposes constraints on container placement, migration or network configuration.

Poor performance and high overhead. Container overlay networks using tunneling techniques (e.g., VXLAN [30]) can completely decouple the containers and the underlay network, allowing configuring container IPs regardless of the underlay network. However, it incurs significant overhead [26, 27, 47, 54]. Our experiments show that, compared to

bare metal, the throughput of a single TCP flow in a tunnel-based overlay network is about 11% lower, while the TCP request-response transaction rate is about 29% lower. Meanwhile, the CPU utilization is much higher in both experiments. There are techniques [25, 26, 44] that aim at accelerating overlay networks by spreading ingress packet processing across multiple CPUs. But the communication overhead of overlay networks is still non-negligible.

Hurt compatibility. Slim [54] and its follow-up works [9, 28, 29] implement overlay network by socket replacement, which allows containerized applications to use the host’s sockets directly. This idea maintains low-overhead and part of the flexibility of overlay container networks. However, it does not natively support non-connection-based protocols (e.g. UDP, ICMP) and container live migration. They may also be incompatible with the tunneling-headers-based policies in the underlay network.

To attain high performance, flexibility, and compatibility at the same time, we design and implement ONCache (**O**verlay **N**etwork **C**ache), which is a container overlay network that offers a cache-based and low-overhead fast path. ONCache can be easily integrated into existing standard overlay networks and has been tested in Antrea [1] and Flannel [18]. Our detailed contributions are summarized as follows:

1. We quantitatively analyze the data path of a standard container overlay network, and identify the *extra data path* of the container overlay network. We find that the processing results on the *extra data path* are nearly the same for packets that belong to the same host pair, container pair or flow (*a.k.a., invariance property*). This property inspires us the design of ONCache.
2. We design caches to store the intra-host routing/filtering decision and the tunneling headers. We adopt a fail-safe design for ONCache: On cache missing, ONCache seamlessly falls back to the standard overlay network and initializes the cache meanwhile.
3. We design a fast path which first (1) checks the cached filtering decision, then (2) prepends/strips the cached tunneling headers to the container packet, and finally (3) redirects the packet to the cached target intra-host interface. With this fast path, ONCache avoids the repetitive filtering, intra-host routing and encapsulating while maintaining the flexibility and compatibility.
4. We evaluate ONCache with microbenchmarks and popular distributed applications. Results demonstrate the significant improvement on throughput (iPerf3 12% higher), latency (transaction rate 36% higher) and CPU utilization (26% lower per-transaction) compared to the standard overlay networks and very limit performance gap to the host network. Applications including Memcached, PostgreSQL and Nginx also benefit from ONCache. ONCache’s source code is publicly available at <https://github.com/nothepeople/ONCache>

This work does not raise any ethical issues.

2 Background and Motivation

We analyze inter-host container networks. Among these networks, the overlay networks have the best flexibility and compatibility. After quantifying the overhead of an overlay network and exploring the recent efforts of reducing the overhead, we offer the motivation/intuition of the design of ONCache.

2.1 Inter-host Container Networks

Container networks are the key to enable containers to communicate with each other and with the external world. We focus on inter-host container networks below. In general, there are three types of inter-host container networks classified by the IPs used by *applications* and the *underlay forwarding*.

Both use host IP. Host network is in this category. Host network offers performance that is very close to that of the bare metal network [47]. However, host network containers share the host’s networking namespace and use the host IP. Therefore, containers on the same host must coordinate ports, which largely hurts the flexibility of applications. This limitation makes host network very rarely used in practice [48].

Both use Container IP. Bridge network and device virtualization techniques, e.g., Macvlan, IPvlan, SR-IOV are in this category. In these networks, each container is assigned a unique IP and is isolated from the host namespace. In bridge networks, all the containers are attached to OVSes [1], bridges [18], or other similar entities, and rely on them to forward packets to the underlay network. In networks with device virtualization techniques, each physical NIC can emulate multiple virtual NICs with different IPs, and attach each virtual NIC to a container. These networks can provide performance that is close to the host network because the data paths are simple.

However, the above approaches have poor flexibility, because they use container IPs in the underlay network. To route container IPs, we should either (1) place all hosts in the same L2 network, or (2) install routing rules for container IPs in the underlay network and manage the routing tables upon any changes of container IPs. These impose constraints on either container placement & migration or network configuration.

App uses container IP and routing uses host IP. Overlay network is in this category. In an overlay network, each container has its own IP, and the container packets are encapsulated using a tunneling protocol (e.g., VXLAN [30] or GENEVE [20]) before sending to containers on other hosts. The overlay network completely decouples the container and the underlay network, and ensures the flexibility of both. However, tunneling incurs extra overhead and hurts performance (see §2.2).

Takeaway #1 Using different IPs in applications and underlay network routing enables the highest flexibility. Due to the importance of flexibility for container networks, we focus on analyzing and improving overlay networks.

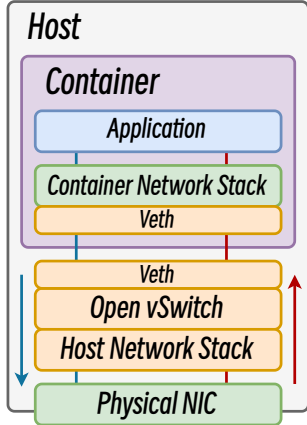

Figure 1: The data path of Antrea.

Part of Data Path	Egress Path		Ingress Path	
Container network stack	30%	Allocating skb Packet filtering Header encapsulating	26%	Header receiving Packet filtering Releasing skb
Veth pair*	6%	Transmit queuing Soft IRQ scheduling	4%	Transmit queuing Soft IRQ scheduling
Open vSwitch*	17%	Intra-host routing Packet filtering	19%	Intra-host routing Packet filtering
Host network stack*	24%	Tunnel encapsulating Packet filtering	21%	Tunnel receiving Packet filtering
Link layer processing	23%	Transmit queuing	30%	GRO Allocating skb

Table 2: The percentage of CPU time and the decomposed overhead of each part of the egress and ingress data path of Antrea. GRO is short for Generic receive offload. “*” denotes that this part of data path is the extra data path compared to the host network.

2.2 Analysis of Overlay Network Overhead

Many former works [26, 27, 47, 54] have demonstrated the poor performance of overlay networks. However, none of them quantitatively analyze the detailed overhead. We quantitatively analyze the overhead of a typical overlay network, Antrea, whose egress and ingress data path is shown in Figure 1. We conduct CPU profiling [38] when Netperf’s TCP_RR (i.e. a 1 byte TCP request-response test) is running. The decomposed overhead and the CPU time of each part of the data path are listed in Table 2.

Container network stack. The container network stack interacts with the application directly. On the egress path, the application first writes data to the sockets. Then the container network stack allocates an `sk_buff` (i.e. socket buffer) for the data and encapsulates each packet layer by layer. Inversely, the ingress path decapsulates the headers and releases the `sk_buff`. Besides, to filter and mangle packets, kernel uses netfilter in the network stack [35]. Netfilter can track connections, filter packets and mangle packets on both ingress and egress path, which incurs overhead. The container network stack takes up 30% and 26% time in the whole processing time of the egress path and the ingress path.

Veth pair. Containers run applications in individual namespaces and use veth pairs [50] to forward packets between the host namespace. Traversing veth pairs incurs overhead, which includes the transmit queuing overhead on the sender veth and the software interrupts scheduling overhead on the receiver veth. In Cilium, the veth pair traversing overhead can be eliminated on the ingress path using `bpf_redirect_peer` [52], but it still exists on the egress path [12]. Veth pair takes up 6% and 4% time on the egress path and the ingress path.

Open vSwitch. The container packets need to be L2/L3 forwarded. The forwarding data path varies in different overlay network implementations. For example, Antrea uses OVS, Flannel uses Linux bridge and Cilium uses `bpf redirect`. Except for `bpf redirect`, all the forwarding data paths incur more

or less forwarding overhead. Besides, there can also be packet filtering and packet mangling on the forwarding data path, which incur additional overhead. In Antrea, OVS takes up 17%/19% time on the egress/ingress path, respectively.

Host network stack. Tunneling protocols encapsulate L2 frames and VXLAN header within L4 UDP datagrams¹. Usually, the encapsulation is done by the host network stack that resides in the host namespace. The stack encapsulates or decapsulates the VXLAN header, UDP header, IP header and MAC header. Netfilter may also track connections and do packet filtering/mangling here. Host network stack takes up 24%/21% time on the egress/ingress path, respectively.

Link layer processing. The link layer processing overhead on the egress path is mainly the transmit queuing at physical NIC; the overhead on the ingress path is mainly caused by allocating socket buffer and GRO (generic receive offload) [19]. On receiving of packets, GRO first tries to coalesce packets from the same flow to larger packets. GRO can reduce the number of packets delivered to the network stack and lower the processing overhead. Link layer processing takes up 23% and 30% time on the egress path and the ingress path.

Takeaway #2 Compared to a bare metal network, we can see that the veth pair, bridge/OVS, and the host network stack are the *extra data path* of the overlay network. The *extra data path* incurs overhead and degrades network performance.

2.3 Related Works on Overlay Network

There are some recent effort that aims to improve the performance of the overlay network.

Socket replacement. Slim [54] introduces a socket replacement mechanism that can improve the performance of container communication. It establishes TCP connections in host namespace and replaces TCP sockets in container by ones in

¹We take VXLAN as an example. The analysis is similar for other kinds of tunneling protocols.

host namespace. While improving the TCP performance, Slim has significant limitations. First, Slim does not support non-connection-based protocols such as UDP, ICMP, which limits its compatibility and debuggability. Second, Slim packets are not tunneling packets, which can affect the policies in underlay network that match on the tunneling headers. Furthermore, when setting up connections, Slim must first establish an overlay connection for service discovery, leading to prolonged connection setup time.

There are some works following the idea of Slim. O2H [9] implements the idea of Slim using eBPF and ptrace. It shares the similar shortcomings as Slim. ShuntFlow [29] uses a threshold mechanism which switches to Slim for long-lived connections and overlay for others. The shortcomings are similar as O2H. SlimFast [28] reduces the connection setup time of Slim and adapts UDP to the socket replacing mechanism by proposing a hash-based service discovery. It is still potentially incompatible with underlay policies, and the proposed UDP mechanism is not yet complete, e.g., the hash-based service discovery cannot handle hash collision.

CPU load balancing. RPS and RFS (and their hardware version RSS and Accelerated RFS) [44] in Linux can improve performance by load balancing packet processing among multiple CPUs. Falcon [26] pipelines software interrupts associated with different network devices of a single flow on multiple cores, thereby preventing execution serialization of softirqs from overloading a single core. mFlow [25] exploits packet-level parallelism by splitting the packets of the same flow into multiple micro-flows, which can be processed on multiple cores. However, these solutions only take effects on the ingress path and cannot further improve the performance if the bottleneck is the egress path. Besides, they improve the network performance at the cost of higher CPU utilization.

Takeaway #3 Though many efforts are made to improve the overlay network, none of them can maintain low overhead, high performance, high flexibility and high compatibility simultaneously.

2.4 Motivation: the Invariance Property

According to the analysis on the overlay network in §2.2, we can further classify the overhead on the *extra data path* (called *extra overhead*) into the following parts: encapsulating, namespaces traversing, intra-host routing, packet filtering and packet mangling. As far as we know, packet mangling (e.g., NAT) in inter-host container communication only happens when Kubernetes ClusterIP Service [46] is enabled, which is separately analyzed in §3.5. For the other four parts, we find that they all exhibit the *invariance property*, i.e., the processing results are nearly the same for packets that belong to the same host pair, container pair or flow.

Encapsulating: The host network stack encapsulates VXLAN, UDP, IP, and MAC headers for each container packet. For simplicity, we refer to the encapsulated headers

as *outer headers*. Most fields in the outer headers for a *given host pair* are invariant: (1) The outer MAC header stores the data of L2 route, VLAN, and Ethernet type, which are invariant (except if there are multiple forwarding paths between a host pair as discussed in 3.5). (2) The outer IP header stores the host IPs, the protocol, ToS, flags, etc, most of which are invariant (also except for multiple forwarding paths scenario). (3) In the outer UDP header, the destination port (VXLAN set to 4789), and the checksum (VXLAN set to 0) are invariant. (4) The VXLAN header stores VNI and also does not change in an overlay network.

Although some fields in the IP and UDP header can vary for different packets, all of them can be easily updated. First, the length in IP and UDP header, and identification in IP header are straightforward to update. Then, for checksum, IP only sums itself and UDP sums headers between itself and the inner IP header [8]. Both calculation is not expensive. Finally, the UDP source port can be calculated by simply hashing the 5-tuple of the inner headers.

Intra-host routing and namespaces traversing: If the intra-host routing is L2 routing, the packet is directly forwarded to the target interface. If it is L3 routing, the MAC addresses should be modified before forwarding the packet to the target interface. In both scenarios, the egress routing decision is invariant for a *given host pair* (also except for multiple forwarding paths scenario), and the ingress routing decision is invariant for a *given container pair*.

Packet filtering: There may be stateless and stateful packet filters. For stateless filters, no matter how complex the filters are, the action is the same for a *given flow*.

Stateful packet filters match on not only the packet fields, but also the state of its flow. They can be used to detect forged packets or unauthorized access. Typically, each tracked flow has a steady state in these filters, e.g., the *established* state. When a flow enters the *established* state, a stateful filter actually reduces to a stateless filter and then the *invariance property* holds. In this paper, we only support stateful packet filters that have a steady state. To the best of our knowledge, most stateful packet filters supported by iptables or OVS fall into this category.

Takeaway #4 Without stateful packet filters, the outer headers, routing and filtering results are invariant for the packets that belong to the same host pair, container pair or flow. Even for stateful filters, the filtering results are also invariant when flows arrive *steady state*. This *invariance property* makes it possible to cache the processing results of the *extra overhead*, and avoid the repetitive processing.

3 ONCache

ONCache is a container overlay network that offers a fast path with low overhead, high performance, high flexibility and high compatibility. ONCache is essentially a plug-in of

eBPF Program	Hook Point
Egress-Prog	TC ingress of the veth (host-side)
Ingress-Prog	TC ingress of the host interface
Egress-Init-Prog	TC egress of the host interface
Ingress-Init-Prog	TC ingress of the veth (container-side)

Table 3: Hook points of the four eBPF programs.

standard overlay networks such as Antrea, Flannel, etc. ONCache adopts a *fail-safe* design: when the fast path is not available, ONCache can seamlessly fall back to the standard overlay network.

Define Cache: Recall from §2.4 that packets that belong to the same host pair, container pair or flow have the invariant outer headers, routing and filtering results. ONCache maintains three local caches (the egress cache, the ingress cache, and the filter cache) on each host to store the invariant results of the *extra overhead*. The detailed design of these local caches is introduced in §3.1.

Init Cache: ONCache relies on a standard overlay network to initialize its caches. On cache missing, ONCache passes the packet to the standard overlay network for processing and stores the processing results in local caches if the packet’s flow arrives the *steady state* (e.g., *established*). See §3.2 for the detailed design. ONCache cannot handle stateful filters without a *steady state*, which is discussed in §3.5.

Utilize Cache: In case of cache hit, ONCache uses the cached outer headers, filtering and routing results to create a tunneling packet and then redirects the packet to the right interface. This cache-based fast path could avoid repetitive processing of the *extra overhead* as analyzed in §2.4. This fast path is transparent to both the application and the underlay network. The detailed design is described in §3.3.

Maintain Cache: ONCache ensures that the outdated cache entries are evicted properly when network changing events (including container deleting, migrating and filter modifying) happen. This is discussed in §3.4.

Cache Compatibility: ONCache focuses on inter-host container networking and should also be compatible with various traffic and features in the network. This is discussed in §3.5.

For ease of implementation and deployment, we implement ONCache with eBPF [16, 51], a technology that runs sandboxed programs in a privileged context such as the kernel. eBPF programs can be attached to kernel hook points (e.g., TC or XDP [22]) and are triggered each time the kernel executes through the hook points. eBPF can store data in a map data struct residing in kernel space, called eBPF map. There are many works that utilize eBPF for networking [3, 33, 42, 49, 53].

ONCache includes the following components, as shown in Figure 2: (1) four eBPF programs for packet mangling and forwarding, the hook points are listed in Table 3; (2) three eBPF maps per host that serve as egress cache, ingress cache, and filter cache; (3) one user space daemon. The design and implementation of ONCache is very simple yet effective. The

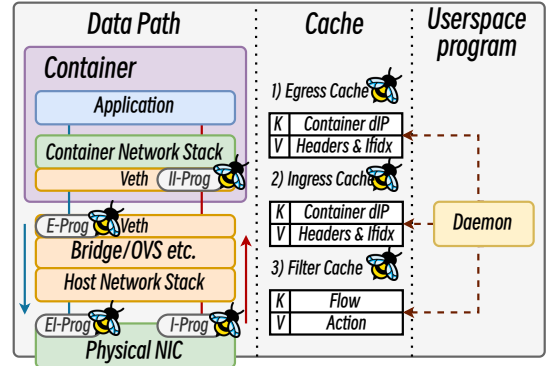

Figure 2: Architecture of ONCache. ONCache consists of 4 eBPF programs in the data path, 3 eBPF maps, and 1 user space program. The components with eBPF logos (“bee”) are eBPF programs or eBPF maps. The “E”, “I”, “EI”, “II” in the 4 eBPF program are short for “egress”, “ingress”, “egress-init”, and “ingress-init”, respectively.

core functionalities can be implemented using only 524 lines of eBPF C code. In contrast, Slim has 2380 lines of code. Falcon is implemented by 606 lines of kernel code, which is harder to implement and debug than eBPF. The core source code is shown in Appendix A.

Our idea is fundamentally different from the former works on the overlay network. Compared to the *CPU load balancing* methods (e.g., RPS/RFS, Falcon), the introduced cache can reduce the overhead and improve the performance of the overlay network without the cost of higher CPU utilization. Compared to the *socket replacement* methods (e.g., Slim), the cache design natively supports all kinds of traffics (rather than only TCP), which maintains the compatibility.

3.1 The Local Cache Definition

Each host in the overlay network has three caches as shown in Figure 2: the egress cache, the ingress cache, and the filter cache. All the caches are implemented by Least Recently Used (LRU) hash map, which evicts the least recently used elements to cache new elements when the cache is full.

The egress cache. The egress cache stores the outer headers² and intra-host routing results on the egress path, which are invariant for packets destined to the same host. The intra-host routing results specify the new inner MAC header (for L3 routing) and egress host interface. So the egress cache is like: $\langle \text{dest host IP} \rightarrow \text{outer headers, inner MAC header, host interface index} \rangle$. We also need a cache that maps from the destination container IP to the destination host IP, called egressip cache: $\langle \text{dest container IP} \rightarrow \text{dest host IP} \rangle$.

The ingress cache. The ingress cache stores the intra-host routing results on the ingress path, which are the same for

²Depends on the adopted tunneling protocol. We take VXLAN as an example in this paper.

packets with the same destination container IP. The intra-host routing results include the $\langle \text{dest container IP} \rightarrow \text{inner MAC header, dest veth (host-side) index} \rangle$.

The filter cache. For stateless filters, the filtering results are the same for the same flow. The filter cache is essentially a flow whitelist where the allowed flows are recorded. The definition of a flow defaults to be the 5-tuple (src IP, dest IP, src port, dest port, transport protocol), and can be changed to any needed definition. For example, the flow can be defined as the 5-tuple together with DSCP field to support DSCP filters. For stateful filters, ONCache only caches the filtering results when a flow arrives *steady state*. The *steady state* is the state that will not change during the communication, e.g., *established* [2]. Thus, ONCache essentially treats stateful filters as stateless ones.

3.2 Cache Initialization

If cache misses when ONCache tries to forward a packet, ONCache will pass the packet to be processed by the fallback overlay network, and try to initialize the cache meanwhile. The cache initialization process is depicted in Figure 3.

Init the Egress Path. The initialization on the egress path is started by Egress-Prog. When a packet is sent out from the container, it first arrives at the Egress-Prog. If experiencing a cache miss during handling the packet, Egress-Prog will first mark the packet as *miss*, which means ONCache cannot handle this packet. The mark is used to pass signals between eBPF programs of ONCache, e.g., Egress-Prog and Egress-Init-Prog. We use one bit in the *tos* field of IP header as the *miss* mark. Then Egress-Prog passes the current packet to the fallback overlay network.

The fallback overlay network normally forwards, filters and encapsulates the packet. To handling stateful packet filters, we should configure the overlay network to do an extra action. It should mark the packet as *steady* if the corresponding flow arrives the *steady state*. We use another bit in the *tos* field of IP header as *steady* mark. In Antrea, the above action can be implemented by adding it to OVS flows seamlessly with two small modifications, see the example in Appendix A.2.

After being processed by the fallback overlay network, the packet arrives at Egress-Init-Prog. The program checks if the requirements are met to initialize the caches: (1) the packet is a tunneling packet (e.g., a VXLAN packet); (2) the packet is marked as *miss*; (3) the packet is marked as *steady*.

If all requirements are met, Egress-Init-Prog initializes the egress cache by storing $\langle \text{dest container IP} \rightarrow \text{dest host IP} \rangle$ and $\langle \text{dest host IP} \rightarrow \text{outer headers, inner MAC header, host interface index} \rangle$ to the cache. ONCache can derive the host interface index from `sk_buff` struct, and the other fields from the tunneling packet. The flow is also whitelisted in the filter cache. After cache initialization, the packet will be sent out from the host interface.

Init the Ingress Path. When a tunneling packet is received

from the host interface, Ingress-Prog queries the cache and tries to forward the packet. As on the egress path, it marks the packet as *miss* on cache missing and passes it to the fallback overlay network.

Then the packet is normally processed by the fallback overlay network until it arrives at the TC ingress of the veth (container-side). The overlay network is also required to mark the packet as *steady* if its flow arrives the *steady state*.

Ingress-Init-Prog then checks if the packet is marked as *miss* and *steady*. If so, the program initializes the cache by storing $\langle \text{dest container IP} \rightarrow \text{inner MAC header} \rangle$ to the ingress cache and whitelisting the flow in the filter cache.

Ingress-Init-Prog cannot learn $\langle \text{dest container IP} \rightarrow \text{veth (host-side) index} \rangle$ by itself. This is stored by the user space daemon at the provision of containers.

3.3 Cache-based Fast Path

We describe the end-to-end workflow of the cache-based fast path of ONCache (see Figure 4). The fast path is designed to be transparent to both applications and the underlay network. ONCache never drops packets. For packets that cannot go through the fast path, ONCache simply passes them to the fallback overlay network.

3.3.1 The Egress Data Path

The functionalities on the egress data path are implemented by Egress-Prog. Egress-Prog operates on the egress container packets in following steps:

Step #1: Packet filtering. Egress-Prog checks the filter cache to see if each container packet is whitelisted to use the cache-based fast path. Only when both directions of a flow are whitelisted in the filter cache, will the flow's packets be processed by ONCache. This can avoid conflicts between ONCache and the conntrack module, as discussed in §3.5.

Step #2: Encapsulating and intra-host routing. Egress-Prog queries the $\langle \text{dest container IP} \rightarrow \text{outer headers, inner MAC header, host interface index} \rangle$ from the egress cache. To avoid conflicting with conntrack, Egress-Prog also checks if the ingress cache for the reversed flow is also ready. If cache missing in either cache, the packet is marked as *miss* and passed to the fallback overlay network.

On cache hitting, Egress-Prog then rewrites the inner MAC header and prepends the outer headers. Two changes should be made on the outer headers: (1) Update the length, identification and checksum fields in the outer IP header and the length field in the outer UDP header; (2) Compute the outer UDP source port based on the inner headers using the same hash function adopted by the kernel.

After all the processing, Egress-Prog calls the eBPF helper function `bpf_redirect` to redirect the packet to the target host interface (whose index is queried above). After Egress-Prog returns, the packet will be redirected by the kernel.

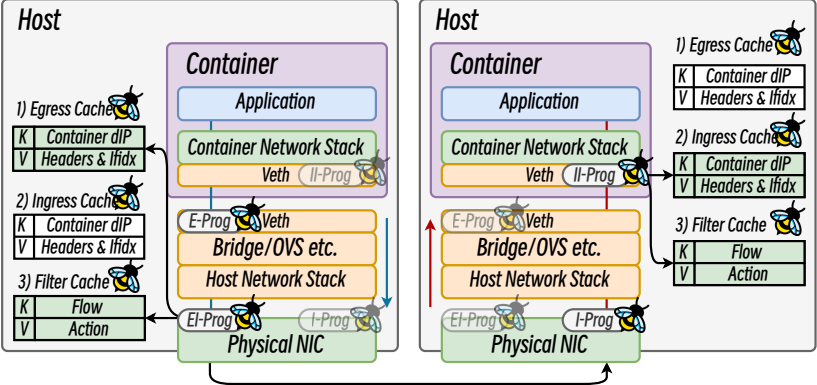

Figure 3: The cache initialization process of ONCache. EI-Prog/II-Prog update the entries (green shaded) when the initialization requirements are met.

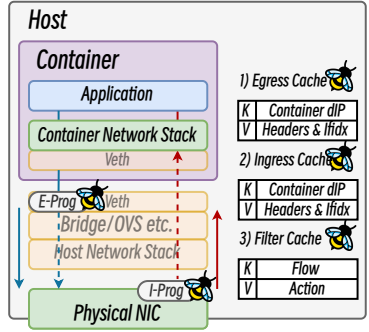

Figure 4: Journey of an overlay packet in ONCache. EI-Prog/II-Prog are skipped over. The dash lines denotes the redirect path.

3.3.2 The Ingress Data Path

The ingress data path is implemented by Ingress-Prog. It decapsulates the ingress tunneling packets and performs packet filtering and intra-host forwarding.

Step #1: Destination checking. On the ingress path, we should first check if the packet arrives correctly. ONCache user space daemon maintains an eBPF map called devmap. It stores the MAC and IP of the local host interfaces. When handling an ingress packet, Ingress-Prog queries the MAC and IP of the host interface from devmap and checks if they match the packet’s MAC and IP. TTL is also checked. If the packet arrives by mistake, Ingress-Prog will pass the packet to the fallback overlay network to further process.

Step #2: Packet filtering. This part of Ingress-Prog is exactly the same as that of Egress-Prog.

Step #3: Decapsulating and intra-host routing. Ingress-Prog queries $\langle \text{dest container IP} \rightarrow \text{inner MAC header}, \text{dest veth (host-side) index} \rangle$ from the ingress cache. The egress cache is also checked to avoid conflicts with conntrack. If both cache hits, Ingress-Prog removes the outer headers of the received tunneling packet, rewrites the inner MAC header and then redirects the packet to the target veth (container-side). The redirecting is done by calling the eBPF helper function `bpf_redirect_peer`.

Although the decapsulation of outer headers is simplified in ONCache, there is no functionality loss. First, the payload is protected by checksums of inner headers, which will still be verified by container network stack. Second, reassembling of the fragmented packets is done by GRO before Ingress-Prog. There are no other functionalities relying on the outer headers.

3.4 Cache Coherency

ONCache offers a cache-based fast path for overlay networks. By design, whether a packet follows the fast path or the original overlay data path, the outcome of the packet should be the same. However, an overlay network is subject to change, in

cases of container deletion, container migration, filter update, etc. ONCache must ensure cache coherency in such scenarios.

Some network changes, such as container provisioning, container deletion, do not require immediate cache deletion or modification. ONCache can natively handle these changes. Container provisioning is handled by cache initialization. For container deletion, ONCache needs no extra action because the useless cache can be evicted by the LRU mechanism. Thanks to this property, an unexpected container failure will not affect cache coherency.

For other changes, such as container migration, filter update, the cache should be properly updated to ensure the correctness of ONCache. The challenge is that the network changes and the cache updates may not be synchronized. Consider a case where a new filter is to be added to deny a flow. If the corresponding filter cache is deleted after the network change, then packets processed in this time gap will still use the old filter; if the corresponding filter cache is deleted before the network change, then a packet processed in this time gap could reinitialize the cache based on the old filter and the new filter may never take effect.

To handle the above challenge, ONCache introduces a *hold-on flag* to ensure a proper sequencing of network changes and cache updates. The whole process have 4 steps: (1) enable the *hold-on flag* to temporarily disable the cache initialization (by disabling the *miss mark*); (2) remove the cache entries affected by the new network change (the affected packets start using the fallback overlay network); (3) apply network changes (the network changes can immediately take effect because all the affected packets go through the fallback overlay network); (4) disable the *hold-on flag* to reinitialize the cache entries (the affected packets can start using the fast path again).

3.5 Cache Compatibility

Handling various traffics. ONCache is designed to accelerate the inter-host container traffic, and is not responsible for other types of traffic, including intra-host container traffic,

container-to-host-IP traffic, container-to-external-IP traffic, etc. These traffic is handled by the fallback overlay network.

The ClusterIP Service [46] in Kubernetes helps containers to access a set of containers offering the same functionality by a single ClusterIP. It is a special overlay traffic, which utilizes packet mangling on its data path. Such Service usually relies on iptables or IPVS on the sender host for load balancing and DNAT. However, ONCache’s fast path naturally bypasses iptables and IPVS. Nevertheless, ONCache can support ClusterIP as how Cilium does: implementing load balancing and DNAT by eBPF programs and maps [11]. This functionality can be inserted before packet filtering in Egress/Ingress-Prog and be compatible with the cache-based fast path.

Enforcing various policies. For filter policies that match on packet fields other than 5-tuple, such as DSCP, ONCache can extend the key of the filter cache and easily support various filters. The overhead of these filters can be eliminated because the *invariance property* still holds. Data-plane policies, such as rate limiting, quality of service (QoS) can work together with ONCache. In Linux, they are enforced by the traffic control program, *tc*. *tc* is compatible with TC eBPF programs.

Policies not supported by ONCache. Packet-based filters match on the hash of the overlay packet [54] and do not exhibit any *invariance property*. For stateful packet filters without a *steady state*, there does not exist a final decision that remains unchanged until the end of a flow. ONCache does not natively support such packet filters. Nevertheless, one can still implement such filters using eBPF case by case.

Compatibility with contrack. Recall from §3.3 that ONCache needs to check both the ingress cache and the egress cache before forwarding a packet to the fast path. The objective is to maintain compatibility with contrack. To understand the reason, let us assume that ONCache only checks the egress cache on the egress data path. Consider the following situation. Flow f has entered the *established* state in contrack and all the cache for f has been initialized. Then all packets of flow f go throughout ONCache’s fast path. Since flow f bypasses the kernel stack, its contrack state expires eventually after a per-defined time. After that, if flow f is evicted from the ingress cache, then flow f can still use the fast path on the egress path, but cannot use the fast path on the ingress path. We hope ONCache could reinitialize the ingress cache for flow f . But unfortunately, the flow f cannot re-enter the *established* state in contrack, because contrack marks a flow as *established* only if it sees packets on both directions [2]. In this case, flow f can no longer utilize the fast path on the ingress data path.

Handling multiple egress interfaces. For containers deployed on a server with multiple egress interfaces, flows between a container pair can be load balanced among multiple egress interfaces at the source host. However, the current design of ONCache binds a destination host to a specific egress interface, making it impossible to utilize multiple egress interfaces. To solve this issue, we can simply modify ONCache to

store the invariant processing results for each flow rather than each destination host, at the cost of higher memory usage.

Compatibility with CNIs. The current implementation of ONCache is based on TC eBPF. For CNIs that do not use TC eBPF in their data path, e.g., Antrea, Flannel, etc., ONCache can be directly plugged in without code modification. To use ONCache with CNIs that already utilize TC eBPF, e.g., Cilium, Calico, etc., we need to re-implement ONCache either in the CNIs’ eBPF programs or in the kernel source code.

Container live migration. ONCache supports live migration. Live migration will cause overlay network changes. ONCache can use the 4 steps proposed in §3.4 to apply such changes. In contrast, Slim only supports cold migration [54].

Network Debugging. ONCache supports ICMP and thus supports common debug tools such as ping, traceroute, etc. Users can also use tools like bpftool [5] to debug the eBPF programs and maps. Debugging in ONCache is easy and convenient. In contrast, Debugging in Slim is much harder. Slim does not support ICMP. There also lacks debug tools for the socket replacement mechanism in Slim.

ONCache is compatible with network techniques like Generic Segmentation Offload (GSO), Generic Receive Offload (GRO) and checksum offload. See Appendix D.

4 Evaluation

We evaluate ONCache in this section. We first evaluate the microbenchmarks. We then evaluate the performance for popular distributed applications, including Memcached [31], PostgreSQL [41], and Nginx [37].

Our testbed is built on top of a base Kubernetes [24] cluster (v1.23.6), including API server, placement engine, etcd, etc. We run the experiments on Cloudlab [15] with three c6525-100g nodes. Each machine has an AMD EPYC 7402P 24-core processor@2.80GHz. The processor uses hyperthreading. Each machine has 128GB ECC memory and a dual-port Mellanox ConnectX-5 Ex 100 GB NIC. The host NIC is configured to use the offload techniques, including TSO, GSO, GRO [45] and checksum offload [8]. Besides, RSS [44] is enabled in all experiments. We use Ubuntu 20.04 with Linux kernel version 5.14. We deploy ONCache as a plugin of the Antrea CNI (encap mode).

ONCache’s performance in the following experiments can be further improved by two optional improvements, at the cost of kernel/protocol modification. See §5 for more details.

4.1 Microbenchmarks

4.1.1 Throughput and Latency

We use iPerf3 [23] to measure the throughput, and use the RR (Request-Response) test in Netperf [36] to measure the request-response transaction rate. The RR test measures the rate of one byte round-trips that can be performed in sequence

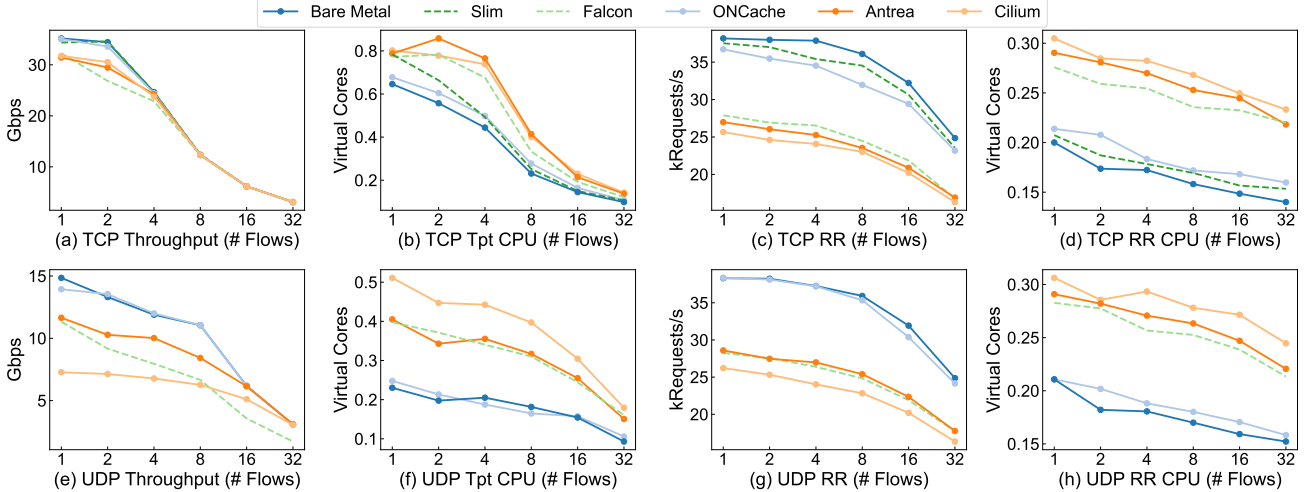

Figure 5: TCP and UDP microbenchmark results of the bare metal, Slim (TCP only), Falcon, ONCache, Antrea and Cilium. Both Cilium and Antrea create standard overlay networks. All the data are the average of a single flow. The CPU data is measured on the receiver host. The CPU data is normalized by throughput or RR and scaled to Antrea’s throughput or RR.

over a connection, and thus higher transaction rate implies lower end-to-end latency. Mpstat [34] is used to measure the CPU utilization. We measure the CPU utilization on the receiver host in all the tests. We run both TCP and UDP tests.

In all settings, we do parallel tests. We deploy multiple container pairs on a pair of hosts. All the server containers are on one host and all the client containers are on the other host. All of the container pairs start testing at the same time. Thus we can evaluate the parallel performance of ONCache.

We choose the most widely used CNIs, Cilium [10] and Antrea [1], to represent the performance of the standard overlay network, which is used as baseline. The intra-host data paths of these CNIs are different. Antrea uses OVS [39], Cilium uses bpf redirect. But both of the overlay networks use tunneling protocol to encapsulate the container packets. We choose the bare metal network performance as the upper bound of overlay networks.

To compare ONCache with the former works discussed in §2.3, we also run the microbenchmark on Slim³ and Falcon, which are the representative solutions for the two former ideas: *socket replacement* and *CPU load balancing*.

TCP microbenchmarks. ONCache significantly improves the throughput and RR results while utilizing fewer CPU resources. The per-flow throughput, RR, and CPU utilization results are shown in Figure 5 (a) – (d).

In the throughput experiments, compared to Antrea, ONCache improves the throughput by 11.53% and 13.96% in 1-parallel and 2-parallel tests. In 4, 8, 16, and 32-parallel experiments, all the container networks saturate the 100Gb physical bandwidth. During the throughput experiments, ONCache reduces per-byte CPU utilization by 13.94% - 34.87% in different parallel tests. The throughput and its CPU utiliza-

tion of ONCache is very close to Slim and bare metal.

For the RR experiments, the RR results of ONCache in all the parallel experiments are 35.81% - 40.91% higher than Antrea, and the per-transaction CPU utilization of ONCache is 26.02% - 32.03% lower. The results of ONCache have a small gap to those of Slim. Because there is residual overhead compared to Slim, e.g., namespace traversing, eBPF execution, tunnel MTU overhead. They can be eliminated by optional improvements proposed in §5. There is also a gap between Slim and bare metal. The reason could be the different code execution efficiency between container and bare metal.

In both throughput and RR tests, Falcon only slightly improves the results. This is because in both tests, single flow does not overwhelm any CPU cores (the utilized virtual core is less than 1). Thus load balancing softirqs to cores can have very limit benefits to the original overlay networks.

Recall from the analysis in §2.2, the CPU utilization reduction in TCP RR of ONCache should be 44% - 47% (overall percentage of the extra data path) in theory. The experimental reduction is smaller (26% - 32%) not only because the residual overhead analyzed above, but also because there is some inherent CPU usage (e.g., background service). Even the utilization reduction of bare metal is only 31% - 39%.

UDP microbenchmarks. The performance of ONCache on UDP is similar with that on TCP, as in Figure 5 (e) – (h). The UDP throughput of ONCache is 19.68% - 31.76% higher than Antrea in 1, 2, 4, 8-parallel experiments. In 16 and 32-parallel experiment, the throughput remains the same because of the bandwidth bottleneck. The per-byte CPU utilization is lower by 29.73% - 47.98% in all experiments. The throughput gap between ONCache and bare metal is smaller than 6%.

ONCache improves the UDP RR performance by 34.13% - 39.12% in the experiments. The per-transaction CPU uti-

³Slim does not support UDP, only the TCP microbenchmark is performed.

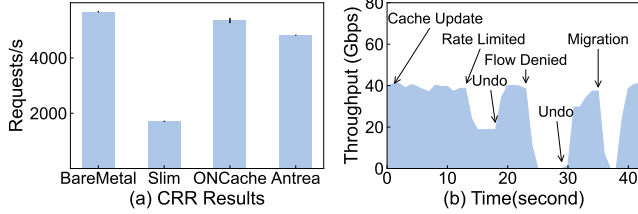

Figure 6: (a) The CRR (Connection-Request-Response) rate of different networks. The higher the better. Error bars denote standard deviations. (b) iPerf3 throughput for functional completeness experiment.

lization is 27.54% - 31.59% lower. There is also a small gap caused by the same reasons as TCP RR tests.

4.1.2 Cache Overhead

Cache Initialization. We use Netperf’s CRR (Connection-Request-Response) test to measure the TCP connection setup time and show the cache initialization overhead. In CRR, each RR transaction needs a new connection, which requires extra cache initialization.

The CRR results are shown in Figure 6(a). ONCache is better than Antrea while worse than bare metal. This is because ONCache relies on Antrea to handle the first 3 packets before cache initialized. ONCache performs the same as Antrea in this part. Then the round trip of 1 byte (Request-Response part) can go through the fast path, which performs better than Antrea. Slim performs significantly worse. The reason is that Slim needs to perform service discover in order to setup connections, which takes several extra RTTs.

Cache interference. We run the iPerf3 test while updating the cache entries in the background. In our test, the sizes of all caches are 512 and the cache replacement policy is LRU. We use a script to continually inserts 1000 useless cache entries and then continually delete them for 2 rounds. The test lasts about 8 seconds. As shown in the first 8 seconds of Figure 6(b), there is no large throughput fluctuation of the iPerf3 flow.

4.1.3 Functional Completeness

Data Plane policies. These policies (e.g., rate limiting, quality of service) are enforced by *tc*. We test if they work properly with ONCache. As shown in Figure 6(b), when there is no rate limiting, the throughput is about 39 Gbps. Then we limit the rate to 20Gb on the host interface. Soon after the policy is applied, the throughput drops to 18.5Gb. The throughput recovers after removing the rate limit.

Packet filter policies. We test if packet filters work properly with ONCache. When running an iPerf3 test with ONCache, we add a simple packet filter which denies the iPerf3 flow in the standard overlay network. The filter is added using the four steps described in §3.4. As expected, the throughput

drops to 0 as shown in Figure 6(b). The throughput recovers after removing the filter.

Live migration. Unlike Slim, ONCache supports container live migration, as discussed in §3.5. Because our Kubernetes-based testbed does not natively support live migration, we simulate it by modifying the host IP and VXLAN tunnels when the containers are alive. As shown in Figure 6(b), the throughput drops to 0 when migration starts (host IP is changed) and recovers once migration finishes (VXLAN tunnels are corrected) after about 2 seconds.

4.2 Applications

We evaluate ONCache on three real-world applications: in-memory key-value store Memcached [31], database PostgreSQL [41] and web server Nginx [37]. We take Antrea as the performance baseline and the Docker host network [13] as the upper bound.

Memcached. We deploy a pair of containers on two hosts. One container runs the Memcached [31] server (v1.6), and the other one runs a standard Memcached benchmark tool *mentier_benchmark* [32] (v2.0.0) as a client. Upon the start of the experiments, the client spawns 4 threads, and each thread starts 50 connections. The ratio of SET and GET requests is 1:10. Memtier runs as fast as possible. We record the CPU utilization by mpstat on client and server hosts during the test.

ONCache achieves much lower latency and higher transaction rate than Antrea. Figure 7(1a) is the CDF graph of the latency of GET requests. The average latency is reduced by 22.71% and 99.9 percentile latency is reduced by 27.69%. The latency gap to the host network is within 6%. The transaction rate (TPS) is shown in Figure 7(1b). ONCache outperforms Antrea by 27.83% and has a 7% gap to the host network.

ONCache also significantly reduces the per-transaction CPU utilization, as shown in Figure 7(1c). The per-transaction CPU utilization of ONCache is 38.91% and 40.98% lower on client and server. The utilization is 4.09% and 6.62% higher than that in the host network.

PostgreSQL. We deploy a database, PostgreSQL [41] (v15.3) in one container and use its benchmark tool, pgbench [40], to test its performance on another container on a different host. Pgbench implements the TPC-B benchmark. It creates a database with 5 million banking accounts and executes 50 clients simultaneously. Pgbench runs as fast as possible.

The PostgreSQL latency and transaction rate are improved with ONCache, as shown in 7(2a) and (2b). Compare to Antrea, ONCache reduces the average latency by 22.34% and the transaction rate by 29.40%. The gap to the host network is 2.3% in latency and 2.54% in transaction rate.

ONCache also reduces the CPU utilization, as shown in Figure 7(2c). ONCache reduces the per-transaction CPU utilization by 51.84% and 7.26% for client and server. The reduction of the server host is smaller because relative high user CPU utilization. ONCache reduces 27.36% of softirq

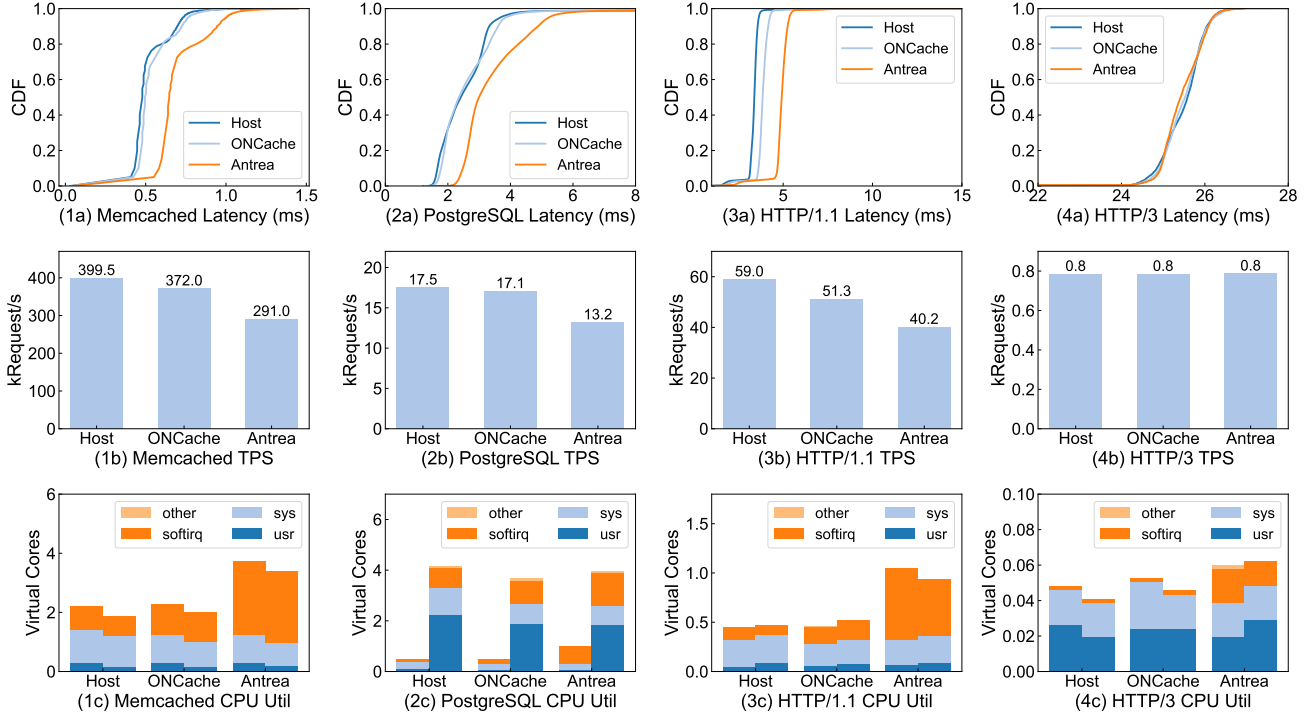

Figure 7: The evaluation results of applications. (1a) - (4a) are the latency CDF graphs; (1b) - (4b) are the transaction rate (TPS) bar graphs; (1c) - (4c) are the CPU utilization of the client (left bar) and server (right bar) hosts during the tests. To make the comparison fair, we normalize the CPU utilization by TPS and scale it to Antrea’s TPS.

utilization on the server host.

Ngix. To evaluate the performance of the HTTP servers, we perform load tests on HTTP/1.1 and HTTP/3 (QUIC) [43], which represent the HTTP protocols that uses TCP and UDP, respectively. In the experiments, SSL is disabled in HTTP/1.1 and enabled in HTTP/3. We use Ngix [37](v1.25.1) and h2load [21](v1.55.1) to benchmark the HTTP server. H2load runs 100 clients for HTTP/1.1 and 10 clients for HTTP/3 (limited by h2load). Each client issues 2 concurrent streams. H2load runs as fast as possible.

ONCache improves the latency and transaction rate for HTTP/1.1 test, as shown in Figure 7 (3a) and (3b). ONCache reduces the HTTP/1.1 request latency by 21.53% and improves the transaction rate by 27.43%. There is a performance gap between ONCache and the host network (15.04% for latency and 13.12% for TPS). It is caused by the same reason as analyzed in TCP RR because the transaction rate is high enough to expose the overhead. For HTTP/3 test, the latency and transaction rate are almost the same for all the networks. We believe that this is limited by the h2load tool.

ONCache reduces the per-transaction CPU utilization for both HTTP/1.1 and HTTP/3, as shown in Figure 7 (3c) & (4c). For HTTP/1.1, the utilization is reduced by 56.26% for client and 43.52% for server. For HTTP/3, the utilization reduction is 11.80% and 26.76% for client and server, respectively.

5 Optional Improvements

We introduce two optional designs to further improve container communication performance. Unlike the original eBPF-based implementation of ONCache, these optional designs require kernel or protocol modifications.

Optimizing the Redirect Data Path. ONCache uses `bpf_redirect` (`bpf_redirect_peer`) to redirect packets on the egress (ingress) path, respectively. As shown in Fig. 8 (a), the two redirect functions are not symmetric. `bpf_redirect` on the egress path cannot eliminate the veth-pair traversing overhead, which leaves an improvement opportunity.

We add a new redirect function to the kernel which offers a reversed path as `bpf_redirect_peer`, called `bpf_redirect_rpeer`. It is used to redirect packets from the egress port of NICs in the non-host namespaces to the egress port of NICs in the host namespace, as shown in Figure 8 (b). This is done in two steps: first, the eBPF program sets the target through `bpf_redirect_rpeer` helper function; then, the kernel gets the target `dev` pointer and rewrites `dev` field in `sk_buff`. This kernel logic is added to `skb_do_redirect`. ONCache can take advantage of `bpf_redirect_rpeer` to further eliminate the veth-pair traversing overhead. With `bpf_redirect_rpeer`, the hook point of Egress-Prog is changed to TC egress of the veth (container-side).

Remark: `bpf_redirect_rpeer` requires kernel modification. We are planning to contribute our code to the Linux kernel.

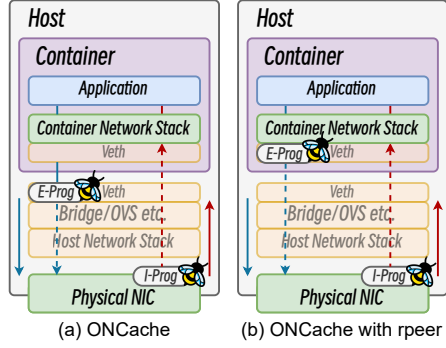

Figure 8: Packet journey in (a) ONCache without rpeer; (b) ONCache with rpeer. With redirect rpeer, the packet can further skip the traversing of veth-pair.

Optimizing the Tunneling Protocol. ONCache does not change the headers of existing overlay network protocols. These overlay network protocols usually create a tunnel first and then encapsulate the original container packets for transmission. The encapsulation typically brings about tens of bytes (e.g., 50 bytes for VXLAN) of transmission overhead. Then, an interesting question raises, can we eliminate such overhead to attain additional performance improvement?

We design a rewriting-based tunneling protocol that avoids the encapsulation overhead. The original container packets use container IPs and container MACs. To enable transmission in the underlay network, we change the IP/MAC fields of each container packet to use the host IP/MAC at the sender host. On the receiver host, we restore the IP/MAC fields to the original container IP/MAC. Note that, we need to introduce a restore key in each container packet, in order to perform the packet restoring step on the receiver host. Each container on the receiver host must have a unique restore key, which is generated during the initialization process. See Appendix B for the detailed design of this new tunneling protocol.

Remark: This protocol modifies the header fields of container packets, and thus may be incompatible with the policies and firewalls in the underlay network.

Evaluation. We evaluate the performance of ONCache with redirect rpeer (ONCache-r), with the rewriting-based tunneling protocol (ONCache-t) and with both of them (ONCache-t-r). We show the application performance of ONCache-r, ONCache-t and ONCache-t-r in Table 4. Other evaluation results are shown in Appendix C.

We find that: (1) The rewriting-based tunneling protocol can improve latency and TPS performance for all applications. (2) The `bpf_redirect_rpeer` can bring more improvement on latency and TPS. Per-transaction CPU utilization is also reduced on PostgreSQL and HTTP/1.1. (3) With both improvements, ONCache-t-r can get a much better latency, TPS and CPU utilization than ONCache. The performance of ONCache-t-r is very close to that of the host network.

Results		ONCache-t	ONCache-r	ONCache-t-r	Host
Memcached	Latency	-2.94%	-7.01%	-6.04%	-5.38%
	TPS	+2.97%	+1.74%	+4.32%	+7.42%
	CPU	+1.92%	+2.14%	-1.10%	-6.21%
PostgreSQL	Latency	+0.04%	-1.28%	-5.77%	-2.25%
	TPS	-0.27%	+1.23%	+6.21%	+2.61%
	CPU	-1.86%	-4.61%	-10.36%	+13.17%
HTTP/1.1	Latency	-2.82%	-8.46%	-10.00%	-13.08%
	TPS	+2.78%	+9.09%	+10.90%	+15.10%
	CPU	-5.48%	-11.93%	-14.02%	-11.26%
HTTP/3	Latency	0.00%	+0.16%	+0.16%	+0.04%
	TPS	-0.03%	-0.03%	-0.01%	-0.03%
	CPU	-26.30%	+15.82%	-10.51%	-10.50%

Table 4: Application performance and server CPU utilization of ONCache-t, ONCache-r, ONCache-t-r and Host network compared to ONCache.

6 Discussion

Why using TC hook? There are two types of hooks that can be used for networking, XDP and TC. Compared to XDP, TC eBPF programs do not require driver support, can redirect packets with lower overhead, is compatible with TC tools and can be hooked on both ingress and egress directions. Therefore, TC is a better choice for ONCache.

RPS/RFS/Accelerated RFS. We do not enable these techniques in evaluation. RPS schedules protocol processing to specific CPUs by the hash of the packet above the interrupt handler, and is redundant when RSS is enabled [44]. RFS/Accelerated RFS steer packets processing to the CPU where application thread is running to increase data cache hit rate. Disabling RFS and Accelerated RFS is the default setting of Cloudlab and does not affect the fairness of the experiments. **Security of eBPF-based ONCache.** The security of eBPF-based ONCache depends on the security of eBPF. In default mode (unprivileged eBPF is enabled), controlling eBPF programs and interacting with eBPF maps are only allowed in privileged mode (root) or require the capability `CAP_BPF` [17]. Thus by controlling the privileged mode and `CAP_BPF` (with unprivileged eBPF enabled), we can easily ensure that only administrators can control eBPF programs and maps. Thus the security of ONCache can be guaranteed.

7 Conclusion

We design and implement ONCache, a cache-based container overlay network, which significantly reduces the performance gap between host networks and overlay networks without losing flexibility and compatibility. For both microbenchmark tests and application performance tests, ONCache’s throughput and latency performance are significantly better than the standard tunneling-based overlay networks, while maintaining low CPU utilization. ONCache can be easily integrated with the existing CNIs, e.g., Antrea, Flannel, etc.

References

- [1] Antrea. <https://antrea.io/>.
- [2] P Ayuso. Netfilter’s connection tracking system. *Login: The Usenix Magazine*, 31:34–39, 2006.
- [3] Matteo Bertrone, Sebastiano Miano, Fulvio Rizzo, and Massimo Tumolo. Accelerating linux security with ebpf iptables. In *Proceedings of the ACM SIGCOMM 2018 Conference on Posters and Demos, SIGCOMM ’18*, page 108–110, New York, NY, USA, 2018. Association for Computing Machinery.
- [4] Bpf and xdp reference. <https://docs.cilium.io/en/stable/bpf/>.
- [5] bpftool. <https://github.com/libbpf/bpftool>.
- [6] Emiliano Casalicchio. *Container Orchestration: A Survey*, pages 221–235. Springer International Publishing, Cham, 2019.
- [7] Emiliano Casalicchio and Stefano Iannucci. The state-of-the-art in container technologies: Application, orchestration and security. *Concurrency and Computation: Practice and Experience*, 32(17):e5668, 2020. e5668 cpe.5668.
- [8] Checksum offloads. <https://docs.kernel.org/networking/checksum-offloads.html>.
- [9] Sunyanan Choochotkaew, Tatsuhiko Chiba, Scott Trent, and Marcelo Amaral. Bypass container overlay networks with transparent bpf-driven socket replacement. In *2022 IEEE 15th International Conference on Cloud Computing (CLOUD)*, pages 134–143, 2022.
- [10] Cilium. <https://cilium.io/>.
- [11] Cilium service load-balancing. <https://docs.cilium.io/en/stable/network/kubernetes/intro/#service-load-balancing>.
- [12] Cni benchmark: Understanding cilium network performance. <https://cilium.io/blog/2021/05/11/cni-benchmark>.
- [13] Docker. <https://www.docker.com/>.
- [14] Docker swarm. <https://docs.docker.com/get-started/orchestration/>.
- [15] Dmitry Duplyakin, Robert Ricci, Aleksander Maricq, Gary Wong, Jonathon Duerig, Eric Eide, Leigh Stoller, Mike Hibler, David Johnson, Kirk Webb, Aditya Akella, Kuangching Wang, Glenn Ricart, Larry Landweber, Chip Elliott, Michael Zink, Emmanuel Cecchet, Snigdhaswin Kar, and Prabodh Mishra. The design and operation of CloudLab. In *2019 USENIX Annual Technical Conference (USENIX ATC 19)*, pages 1–14, Renton, WA, July 2019. USENIX Association.
- [16] ebpf. <https://ebpf.io/>.
- [17] ebpf safety. <https://ebpf.io/what-is-ebpf/#ebpf-safety>.
- [18] Flannel. <https://github.com/flannel-io/flannel>.
- [19] Generic receive offload. <https://docs.kernel.org/networking/segmentation-offloads.html#generic-receive-offload>.
- [20] Jesse Gross, Ilango Ganga, and T. Sridhar. Geneve: Generic Network Virtualization Encapsulation. RFC 8926, November 2020.
- [21] h2load. <https://nghttp2.org/documentation/h2load-howto.html>.
- [22] Toke Høiland-Jørgensen, Jesper Dangaard Brouer, Daniel Borkmann, John Fastabend, Tom Herbert, David Ahern, and David Miller. The express data path: Fast programmable packet processing in the operating system kernel. In *Proceedings of the 14th International Conference on Emerging Networking EXperiments and Technologies, CoNEXT ’18*, page 54–66, New York, NY, USA, 2018. Association for Computing Machinery.
- [23] iperf. <https://iperf.fr/iperf-download.php>.
- [24] Kubernetes. <https://kubernetes.io/>.
- [25] Jiaxin Lei, Manish Munikar, Hui Lu, and Rao Jia. Accelerating packet processing in container overlay networks via packet-level parallelism. In *2023 IEEE International Parallel and Distributed Processing Symposium (IPDPS)*, pages 79–89, 2023.
- [26] Jiaxin Lei, Manish Munikar, Kun Suo, Hui Lu, and Jia Rao. Parallelizing packet processing in container overlay networks. In *Proceedings of the Sixteenth European Conference on Computer Systems, EuroSys ’21*, page 261–276, New York, NY, USA, 2021. Association for Computing Machinery.
- [27] Jiaxin Lei, Kun Suo, Hui Lu, and Jia Rao. Tackling parallelization challenges of kernel network stack for container overlay networks. In *11th USENIX Workshop on Hot Topics in Cloud Computing (HotCloud 19)*, Renton, WA, July 2019. USENIX Association.
- [28] Fusheng Lin, Xin Zhang, Guo Chen, Li Chen, Kenli Li, and Hongbo Jiang. Slim and fast: Low-overhead container overlay network with fast connection setup. *IEEE Transactions on Cloud Computing*, pages 1–13, 2023.

- [29] Hao Liu, Wenxin Li, Yiren Pang, Renjie Pei, Yitao Hu, Yuan Liu, Lide Suo, and Keqiu Li. Accelerating data delivery of latency-sensitive applications in container overlay network. *IEEE Transactions on Parallel and Distributed Systems*, pages 1–13, 2023.
- [30] Mallik Mahalingam, Dinesh Dutt, Kenneth Duda, Puneet Agarwal, Larry Kreeger, T. Sridhar, Mike Bursell, and Chris Wright. Virtual eXtensible Local Area Network (VXLAN): A Framework for Overlaying Virtualized Layer 2 Networks over Layer 3 Networks. RFC 7348, August 2014.
- [31] memcached. <https://memcached.org/>.
- [32] memtier_benchmark. https://github.com/RedisLabs/memtier_benchmark.
- [33] Sebastiano Miano, Fulvio Rizzo, Mauricio Vásquez Bernal, Matteo Bertrone, and Yunsong Lu. A framework for eBPF-based network functions in an era of microservices. *IEEE Transactions on Network and Service Management*, 18(1):133–151, 2021.
- [34] Mpstat. <https://linux.die.net/man/1/mpstat>.
- [35] netfilter. <https://www.netfilter.org/>.
- [36] Netperf. <https://hewlettpackard.github.io/netperf/>.
- [37] Nginx. <https://nginx.org/>.
- [38] perf: Linux profiling with performance counters. https://perf.wiki.kernel.org/index.php/Main_Page.
- [39] Ben Pfaff, Justin Pettit, Teemu Koppinen, Ethan Jackson, Andy Zhou, Jarno Rajahalme, Jesse Gross, Alex Wang, Joe Stringer, Pravin Shelar, Keith Amidon, and Martin Casado. The design and implementation of open vSwitch. In *12th USENIX Symposium on Networked Systems Design and Implementation (NSDI 15)*, pages 117–130, Oakland, CA, May 2015. USENIX Association.
- [40] pgbench. <https://www.postgresql.org/docs/current/pgbench.html>.
- [41] PostgreSQL. <https://www.postgresql.org/>.
- [42] Shixiong Qi, Leslie Monis, Ziteng Zeng, Ian-chin Wang, and K. K. Ramakrishnan. Spright: Extracting the server from serverless computing! high-performance eBPF-based event-driven, shared-memory processing. In *Proceedings of the ACM SIGCOMM 2022 Conference, SIGCOMM '22*, page 780–794, New York, NY, USA, 2022. Association for Computing Machinery.
- [43] Quic. <https://www.chromium.org/quic/>.
- [44] Scaling in the linux networking stack. <https://docs.kernel.org/networking/scaling.html>.
- [45] Segmentation offloads. <https://docs.kernel.org/networking/segmentation-offloads.html>.
- [46] Service. <https://kubernetes.io/docs/concepts/services-networking/service/>.
- [47] Kun Suo, Yong Zhao, Wei Chen, and Jia Rao. An analysis and empirical study of container networks. In *IEEE INFOCOM 2018 - IEEE Conference on Computer Communications*, pages 189–197, 2018.
- [48] The kubernetes network model. <https://kubernetes.io/docs/concepts/services-networking/>.
- [49] William Tu, Yi-Hung Wei, Gianni Antichi, and Ben Pfaff. Revisiting the open vswitch dataplane ten years later. In *Proceedings of the 2021 ACM SIGCOMM 2021 Conference, SIGCOMM '21*, page 245–257, New York, NY, USA, 2021. Association for Computing Machinery.
- [50] veth. <https://man7.org/linux/man-pages/man4/veth.4.html>.
- [51] Marcos A. M. Vieira, Matheus S. Castanho, Racyus D. G. Pacífico, Elerson R. S. Santos, Eduardo P. M. Câmara Júnior, and Luiz F. M. Vieira. Fast packet processing with eBPF and xDP: Concepts, code, challenges, and applications. *ACM Comput. Surv.*, 53(1), feb 2020.
- [52] Virtual ethernet device optimization with eBPF. <https://cilium.io/blog/2020/11/10/cilium-19/#veth>.
- [53] Yang Zhou, Zezhou Wang, Sowmya Dharanipragada, and Minlan Yu. Electrode: Accelerating distributed protocols with eBPF. In *20th USENIX Symposium on Networked Systems Design and Implementation (NSDI 23)*, pages 1391–1407, Boston, MA, April 2023. USENIX Association.
- [54] Danyang Zhuo, Kaiyuan Zhang, Yibo Zhu, Hongqiang Harry Liu, Matthew Rockett, Arvind Krishnamurthy, and Thomas Anderson. Slim: OS kernel support for a Low-Overhead container overlay network. In *16th USENIX Symposium on Networked Systems Design and Implementation (NSDI 19)*, pages 331–344, Boston, MA, February 2019. USENIX Association.

A The Core Code of ONCache

In this section, we provide the core code of the eBPF programs to help to understand the design of ONCache.

A.1 The Local Cache Definition

The code in this section implements functionalities that are described in §3.1.

The egress cache:

```
1 struct egressinfo {
2     unsigned char outer_header[64];
3     __u32 ifidx;
4 };
5 struct bpf_elf_map SEC("maps") egressip_cache = {
6     .type = BPF_MAP_TYPE_LRU_HASH,
7     .size_key = sizeof(__be32),
8     .size_value = sizeof(__be32),
9     .pinning = PIN_GLOBAL_NS,
10    .max_elem = 4096
11 };
12 struct bpf_elf_map SEC("maps") egress_cache = {
13     .type = BPF_MAP_TYPE_LRU_HASH,
14     .size_key = sizeof(__be32),
15     .size_value = sizeof(struct egressinfo),
16     .pinning = PIN_GLOBAL_NS,
17     .max_elem = 1024,
18 };
```

The ingress cache.

```
1 struct ingressinfo {
2     __u32 ifidx;
3     unsigned char dmac[ETH_ALEN];
4     unsigned char smac[ETH_ALEN];
5 };
6 struct bpf_elf_map SEC("maps") ingress_cache = {
7     .type = BPF_MAP_TYPE_LRU_HASH,
8     .size_key = sizeof(__be32),
9     .size_value = sizeof(struct ingressinfo),
10    .pinning = PIN_GLOBAL_NS,
11    .max_elem = 1024,
12 };
```

The filter cache.

```
1 struct action {
2     __u16 ingress;
3     __u16 egress;
4 };
5 struct bpf_elf_map SEC("maps") filter_cache = {
6     .type = BPF_MAP_TYPE_LRU_HASH,
7     .size_key = sizeof(struct fivetuple),
8     .size_value = sizeof(struct action),
9     .pinning = PIN_GLOBAL_NS,
10    .max_elem = 4096,
11 };
```

A.2 Cache Initialization

The code in this section implements functionalities that are described in §3.2.

The egress data path. The TC_ACT_OK return value indicates the kernel to continue to process the packet as usual. ONCache uses TC_ACT_OK to pass the packet to the fallback overlay network.

```
1 // Checks if miss and steady marked.
2 if ((inner_iph->tos & 0xc) != 0xc) return TC_ACT_OK;
3 // Update filter cache
4 struct fivetuple tuple_;
5 if (parse_5tuple_e(inner_iph, data_end, &tuple_) return
6     TC_ACT_OK;
7 struct action eaction_ = {
8     .egress = 1,
9     .ingress = 0
10 };
11 if (bpf_map_update_elem(&filter_cache, &tuple_, &eaction_,
12     BPF_NOEXIST)) {
13     struct action* action_ =
14         bpf_map_lookup_elem(&filter_cache, &tuple_);
15     if (action_) action_->egress = 1;
16 }
17 // Update egress cache
18 struct egressinfo egressinfo_;
19 initegressinfo(&egressinfo_, skb);
20 if (bpf_map_update_elem(&egress_cache, &outer_iph->daddr,
21     &egressinfo_, BPF_NOEXIST))
22     return TC_ACT_OK;
23 if (bpf_map_update_elem(&egressip_cache, &inner_iph->daddr,
24     &outer_iph->daddr, BPF_NOEXIST))
25     return TC_ACT_OK;
26 // Erase the TOS mark.
27 set_ip_tos(skb, 50, 0);
```

The ingress data path.

```
1 // Checks if miss and steady marked.
2 if ((iphdr->tos & 0xc) != 0xc) return TC_ACT_OK;
3 // Update ingress cache
4 struct ingressinfo* ingressinfo_ =
5     bpf_map_lookup_elem(&ingress_cache, &iphdr->daddr);
6 if (!ingressinfo_) {
7     return TC_ACT_OK;
8 } else {
9     __builtin_memcpy(ingressinfo_->dmac, eth->h_dest,
10     ETH_ALEN);
11     __builtin_memcpy(ingressinfo_->smac, eth->h_source,
12     ETH_ALEN);
13 }
14 // Update filter cache
15 struct fivetuple tuple_;
16 if (parse_5tuple_in(iphdr, data_end, &tuple_) return
17     TC_ACT_OK;
18 struct action eaction_ = {
19     .egress = 0,
20     .ingress = 1
21 };
22 if (bpf_map_update_elem(&filter_cache, &tuple_, &eaction_,
23     BPF_NOEXIST)) {
24     struct action* action_ =
25         bpf_map_lookup_elem(&filter_cache, &tuple_);
26     if (action_) action_->ingress = 1;
27 }
```

```

// Drop packets reported as invalid by contrack.
table=ContrackState, priority=210,ct_state=+inv+trk,ip actions=drop
// Forwarded tracked Service packets
table=ContrackState, priority=200,ct_state=-new+trk,ct_mark=0x10/0x10,ip\
actions=Load:0x1->NXM_OF_IP_TOS[3],Load:0x1->NXM_NX_REG0[9],\
resubmit(,AntreaPolicyEgressRule)
// Forwarded tracked non-Service packets
table=ContrackState, priority=190,ct_state=-new+trk,ip \
actions=Load:0x1->NXM_OF_IP_TOS[3],resubmit(,AntreaPolicyEgressRule)
// Match the first packet of untracked connection and forward it
table=ContrackState, priority=0 actions=resubmit(,PreRoutingClassifier)

```

Figure 9: Parts of OVS flows in Antrea. The red part is our added action to mark a bit in tos field.

```

22 // Erase the TOS mark.
23 set_ip_tos(skb, 0, 0);

```

OVS flow modification. In our Antrea cluster, we modify two OVS flows to help ONCache to support stateful filters, as shown in Figure 9.

Originally, the modified two flows are used to forward the non-new-state tracked packets. We can utilize the two flows to mark the *steady state* packets meanwhile. The red font part is our added action, which set 1 to a predefined TOS bit.

A.3 Cache-based Fast Path

The code in this section implements functionalities that are described in §3.3.

A.3.1 The Egress Data Path

Step #1: Policy enforcing.

```

1 // Step #1: Policy Enforcing
2 struct fivetuple tuple_;
3 if (parse_stuple_e(iphdr, data_end, &tuple_)) return
    TC_ACT_OK;
4 struct action *action_ =
    bpf_map_lookup_elem(&filter_cache, &tuple_);
5 if (!action_ || !(action->ingress & action->egress)) {
6     set_ip_tos(skb, 0, 0x4);
7     return TC_ACT_OK;
8 }

```

Step #2: Encapsulating and intra-host routing.

```

1 // Step #2: The encapsulating and intra-host routing.
2 __be32* nodeip_ = bpf_map_lookup_elem(&egressip_cache,
    &iphdr->daddr);
3 if (!nodeip_) {
4     // TOS 0x4 is used as miss mark
5     set_ip_tos(skb, 0, 0x4);
6     return TC_ACT_OK;
7 }
8 struct egressinfo* egressinfo_ =
    bpf_map_lookup_elem(&egress_cache, nodeip_);
9 if (!egressinfo_) {
10     set_ip_tos(skb, 0, 0x4);
11     return TC_ACT_OK;
12 }
13 struct ingressinfo* ingressinfo_ =
    bpf_map_lookup_elem(&ingress_cache, &iphdr->saddr);

```

```

14 if (!ingressinfo_ || !ingressinfo_complete(ingressinfo_))
15     return TC_ACT_OK;
16 // Prepend the outer headers
17 if (bpf_skb_adjust_room(skb, 50, BPF_ADJ_ROOM_MAC,
    BPF_F_ADJ_ROOM_FIXED_GSO |
    BPF_F_ADJ_ROOM_ENCAP_L3_IPV4 |
    BPF_F_ADJ_ROOM_ENCAP_L4_UDP |
    BPF_F_ADJ_ROOM_ENCAP_L2(14) |
    BPF_F_ADJ_ROOM_ENCAP_L2_ETH))
18     return TC_ACT_OK;
19 // Boundary check
20 ...
21
22 // Headers includes 50B of outer hdr and 14B inner MAC hdr.
23 __builtin_memcpy(data, egressinfo->headers, 64);
24 set_lengthandid(skb, skb->len);
25 // Set the UDP source port
26 __u32 hash = bpf_get_hash_recalc(skb);
27 __be16 sport = get_udpsport(hash);
28 bpf_skb_store_bytes(skb, UDP_PORT_OFF, &sport,
    sizeof(sport), 0);
29 // Packet redirecting
30 action = bpf_redirect(egressinfo->ifidx, 0);
31 return action;

```

A.3.2 The Ingress Data Path

Step #1: Destination checking.

```

1 struct bpf_elf_map SEC("maps") devmap = {
2     .type = BPF_MAP_TYPE_HASH,
3     .size_key = sizeof(int),
4     .size_value = sizeof(struct devinfo),
5     .pinning = PIN_GLOBAL_NS,
6     .max_elem = 8,
7 };
8
9 // Step #1: Destination checking
10 struct ethhdr *outer_eth = data;
11 int ifindex = ctx->ifindex;
12 struct devinfo *devinfo_ = bpf_map_lookup_elem(&devmap,
    &ifindex);
13 if (!devinfo_ || memcmp(outer_eth->h_dest, devinfo->mac,
    ETH_ALEN)) return TC_ACT_OK;
14 // Check if Ethernet frame has IP packet and set IP hdr ptr
15 if (outer_eth->h_proto != bpf_htons(ETH_P_IP)) return
    TC_ACT_OK;
16 struct iphdr *outer_iph = (struct iphdr *) (outer_eth + 1);
17 if (outer_iph->daddr != devinfo->ip) return TC_ACT_OK;

```

Step #2: Policy enforcing.

```

1 // Step #2: Policy Enforcing
2 struct fivetuple tuple_;
3 if (parse_stuple_in(inner_iph, data_end, &tuple_)) return
    TC_ACT_OK;
4 struct action *action_ =
    bpf_map_lookup_elem(&filter_cache, &tuple_);
5 if (!action_ || !(action->ingress & action->egress)) {
6     set_ip_tos(skb, 50, 0x4);
7     return TC_ACT_OK;
8 }

```

Step #3: Decapsulating and intra-host routing.

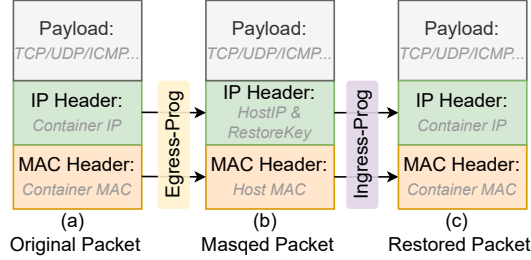

Figure 10: The changes of an overlay network packet for forwarded by ONCache with the rewriting-based tunneling protocol. (a) The original packet from containers. (b) The masqueraded packet. (c) The restored packet.

```

1 // Step #3: The decapsulating and intra-host routing.
2 struct ingressinfo* ingressinfo_ =
    bpf_map_lookup_elem(&ingress_cache,
        &inner_iph->daddr);
3 if (!ingressinfo_ || !ingressinfo_complete(ingressinfo_)) {
4     set_ip_tos(skb, 50, 0x4);
5     return TC_ACT_OK;
6 }
7 if (!bpf_map_lookup_elem(&egressip_cache,
    &inner_iph->saddr)) return TC_ACT_OK;
8 if (bpf_skb_adjust_room(ctx, -50, BPF_ADJ_ROOM_MAC, 0))
    return TC_ACT_OK;
9 // Boundary check
10 ...
11
12 // Set new MAC
13 struct ethhdr *eth = data;
14 __builtin_memcpy(eth->h_dest, ingressinfo_->dmac,
    ETH_ALEN);
15 __builtin_memcpy(eth->h_source, ingressinfo_->smac,
    ETH_ALEN);
16 // Packet redirecting
17 action = bpf_redirect(ingressinfo_->ifidx, 0);
18 return action;

```

B Rewriting-based Tunneling Protocol

This section introduces the how the rewriting-based tunneling protocol works in ONCache. Then the adjustment of the cache and the new initialization mechanism are introduced.

The rewriting-based tunneling protocol replaces the encapsulating of outer headers in common tunneling protocols by rewriting the inner headers. The changes of the packet headers on the data path is shown in Figure 10.

The packet journey. On the sender host, ONCache masquerades the container packets in Egress-Prog. Egress-Prog queries the host interface index, IP and MAC addresses by the destination container IP from the egress cache. Then Egress-Prog rewrites the container IP and MAC to host IP and MAC.

To make sure the masqueraded packet can be restored back on the receiver host, ONCache also needs to write a restore key to the packet during masquerading. Then the receiver host can use the restore key together with the host IP to restore

back container IP and MAC addresses. The restore key is allocated during the cache initialization and is also stored in the egress cache. The specific field to write the restore key depends on the user’s choice. It can be written to any fields in the IP header that are useless during forwarding, e.g., ID, DSCP, and Option. The capacity of the restore key depends on the width of the chosen field. After writing the restore key to the packet, which is called the masqueraded packet, Egress-Prog redirects it to the host interface by `bpf_redirect` or `bpf_redirect_rpeer`.

On the receiver host, Ingress-Prog restores the masqueraded packet back. Ingress-Prog queries the veth (host-side) index, container IP and MAC from the ingress cache by the host IP and the restore key. Then the container IP and MAC are written back to the headers. After restoring, the packet is redirected to the destination veth by `bpf_redirect_peer`.

The new cache. To support the rewriting-based tunneling protocol, the egress/ingress cache should be redesigned.

The egress cache stores data used in masquerading, includes: the src/dest host MAC, the src/dest host IP, host interface index and the preallocated restore key. The destination container IP is used as the key.

The ingress cache stores data used in restoring, includes: the src/dest container MAC, the src/dest container IP, container interface index. The key of the cache is the restore key together with the host IP. To fit in the new initialization process, the ingress cache is divided to two maps. The first is $\langle \text{restore key} \ \& \ \text{host IP} \rightarrow \text{src/dest container IP} \rangle$, and the second is $\langle \text{dest container IP} \rightarrow \text{container MAC} \ \& \ \text{interface index} \rangle$.

The new cache initialization. The initialization of the MAC, IP addresses and interface indexes is similar with the original design (described in §3.2), while the allocating of the restore key is newly added. The restore key is allocated on the receiver host and delivered to the sender host. This can make sure the usage of the restore key in masquerading happens after the receiver host recognizes the restore key. The initialization of the filter cache is the same as described in §3.2 and is omitted in this part. ONCache uses a round-trip of the tunneling packets to initialize the cache. The process is shown in Figure 11 with four steps:

Step #1 (tagged in Figure 11 ①): Egress-Prog passes the packet to the fallback overlay network on cache missing. Then the packet arrives at Egress-Init-Prog after the packet is encapsulated. Egress-Init-Prog parses the host MAC and IP in the outer headers and the host interface index, and stores them to the egress cache. Then a restore key is allocated for the reverse flow, in random or sequence. Together with the host IP, the restore key is written to the IngressIP cache with the container IP as the value. As a hash map, the Ingress IP cache can naturely guarantee the uniqueness of the allocated key. To deliver the restore key to the sender host, the restore key is written to the user-defined field in the inner header. Finally, the packet is sent out to the underlay network.

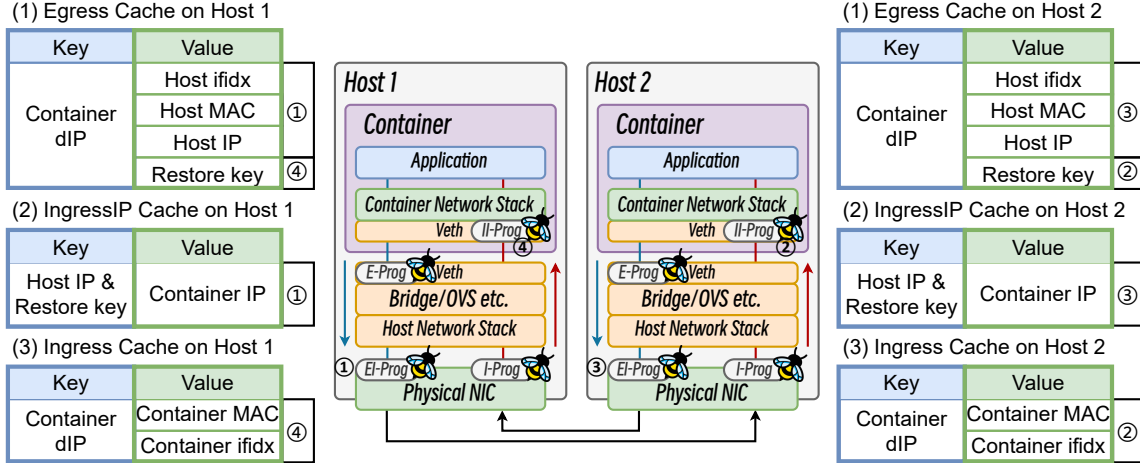

Figure 11: The cache initialization process of ONCache with rewriting-based tunneling protocol. ① - ④ mark the four steps where part of the cache is filled up. The filled fields is also marked in the table (a) - (d). To fit in the new initialization, the ingress cache is divided to two separate maps.

Step #2 (tagged in Figure 11 ②): When receiving an tunneling packet on the receiver host and arrived at Ingress-Init-Prog, the program parses the restore key that has been written to the user-defined field, and stores it to the egress cache. Then the container MAC addresses of the inner headers are stored in the ingress cache (the veth (host-side) index is filled up by the daemon). After the processing, the packet is passed out and arrives at the destination application.

The above process can fill up half of the egress cache and ingress cache on both hosts. Then the reply of this tunneling packet will go through a similar but reverse process (tagged in Figure 11 ③ and ④) and finishes the whole initialization process.

C Evaluation of Optional Improvements

This section, we show more evaluation results for ONCache with optional improvements.

Microbenchmarks. We evaluate ONCache with redirect rpeer and rewriting-based tunneling protocol by the methods described in §4.1. The results are shown in Figure 12.

The optional improvements can improve the latency performance, as shown in Figure 12 (c)(g). For 1-parallel TCP transaction rate, ONCache-t, ONCache-r and ONCache-t-r can improve it by 1.96%, 0.97% and 3.08%, respectively. For UDP tests, they can improve the 1-parallel transaction rate by 2.04%, 2.43%, and 5.87%, respectively. We find that the improvement of ONCache-t-r is the most and approximately the sum of that of ONCache-t and ONCache-r. For multi-parallel tests, the transaction rate is also improved by the optional improvements. Note that ONCache-t-r gets almost the same transaction rate as Slim.

The optional improvements can further reduce the CPU

utilization, as shown in Figure 12 (b)(d)(f)(h). In both throughput and RR tests, ONCache with the optional improvements have positive impact on the CPU utilization. The CPU utilization improvement is not stable in different multi-parallel tests. This is caused by the noise from other processes in the system.

Application experiments. We run application tests on ONCache-r, ONCache-t and ONCache-t-r. The improvement data is listed in Table 4. We further plot the results in Figure 13, Figure 14 and Figure 15.

D Compatibility Discussions

GSO/GRO. The hooking points of all the ONCache eBPF programs are TC. On the egress path, GSO happens after TC [4]. When using redirect rpeer on the egress path, the packets will skip over the GSO at the veth. But they can be then segmented by GSO or TSO (hardware offload of GSO) at the physical NIC. On the ingress path, GRO happens before TC [4] and has no conflicts with ONCache. Therefore, ONCache is compatible with GSO/GRO.

Checksum offload. In standard overlay network, inner TCP checksum offload is often enabled to reduce the overhead. ONCache is compatible with this checksum offload mechanism. We enable both tx and rx checksum offload in all the experiments. Note that IP checksum is always done in kernel [8].

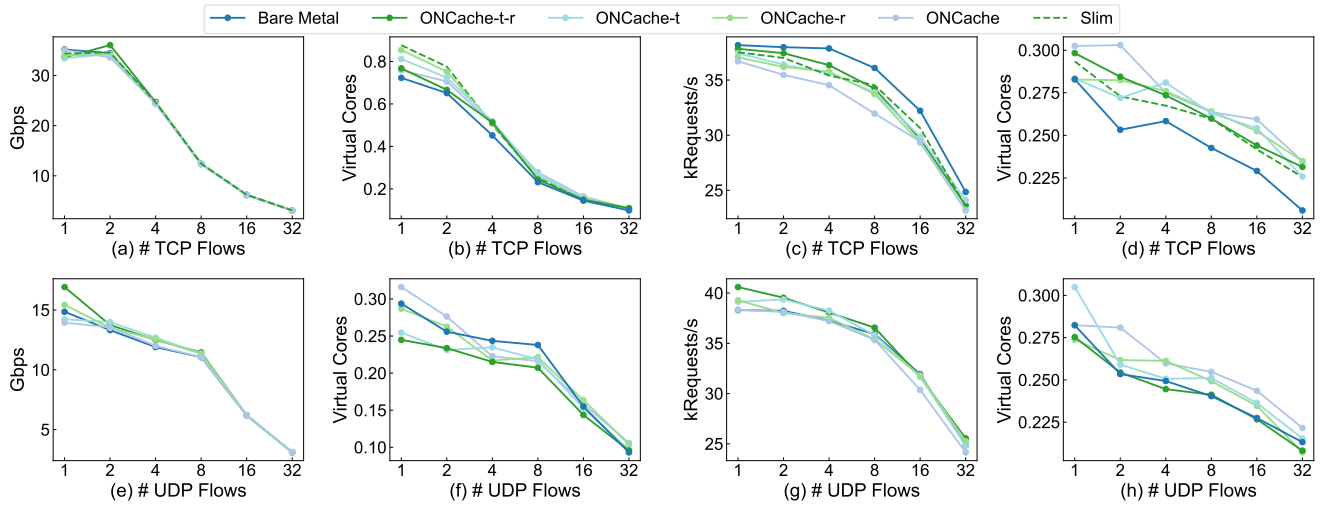

Figure 12: TCP and UDP microbenchmark results of the host network, ONCache with redirect rpeer (ONCache-r), ONCache with rewriting-based tunneling protocol (ONCache-t), ONCache with redirect rpeer + rewriting-based tunneling protocol (ONCache-t-r), and ONCache. All the data are the average of a single flow. The CPU data is measured on the receiver host. The CPU data is normalized by throughput or RR and scaled to bare metal's throughput or RR.

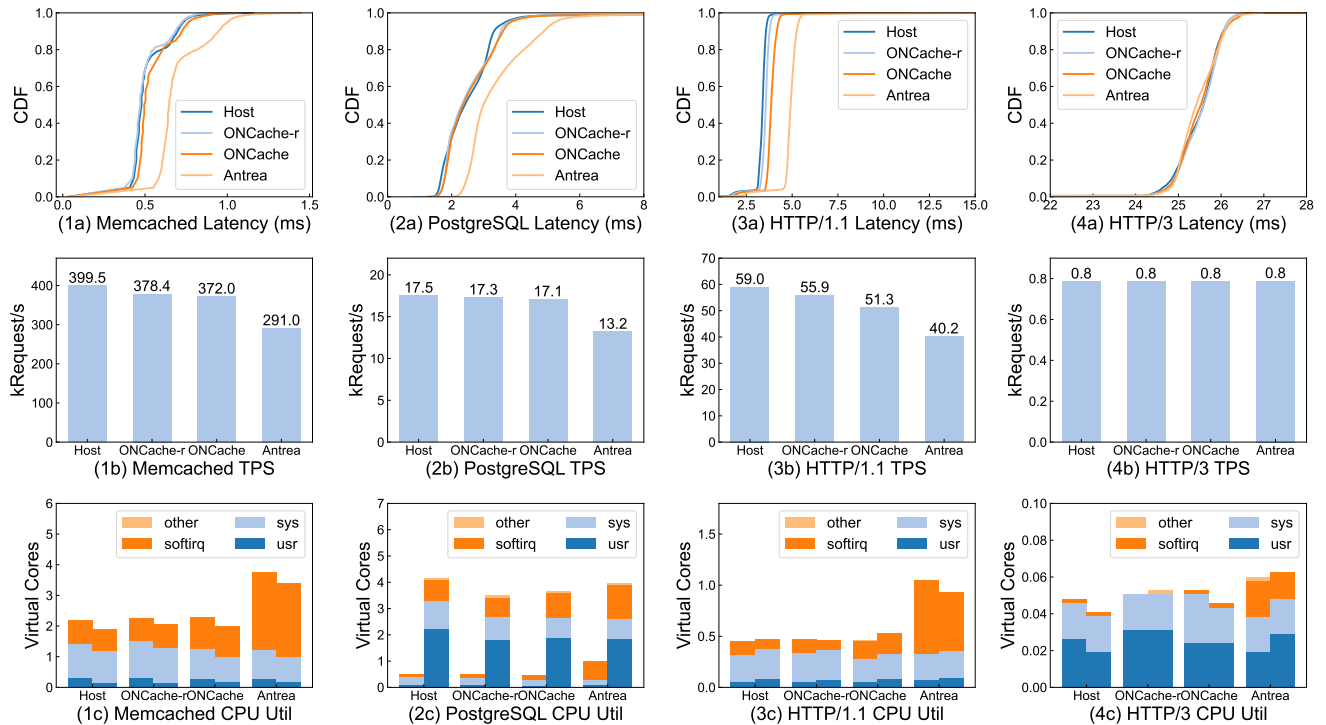

Figure 13: Application performance of Host, ONCache, ONCache with redirect rpeer (ONCache-r).

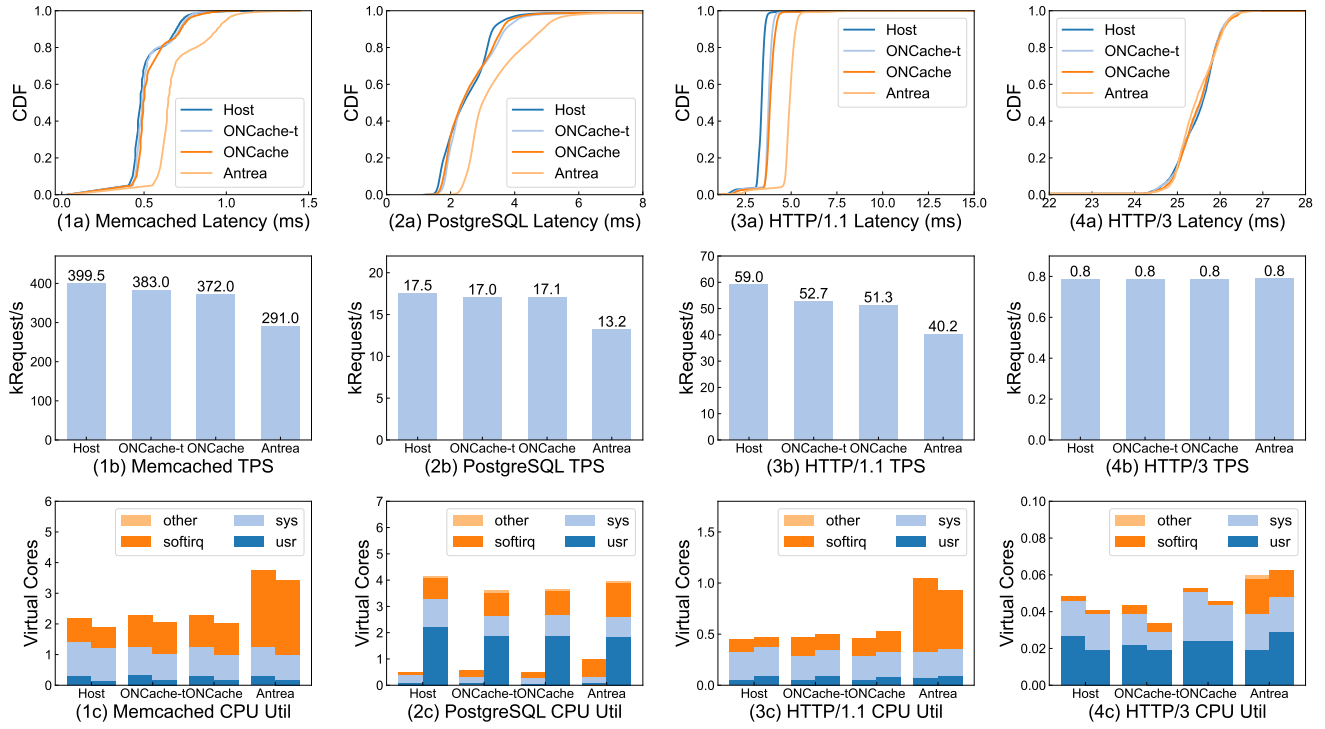

Figure 14: Application performance of Host, ONCache, ONCache with rewriting-based tunneling protocol (ONCache-t).

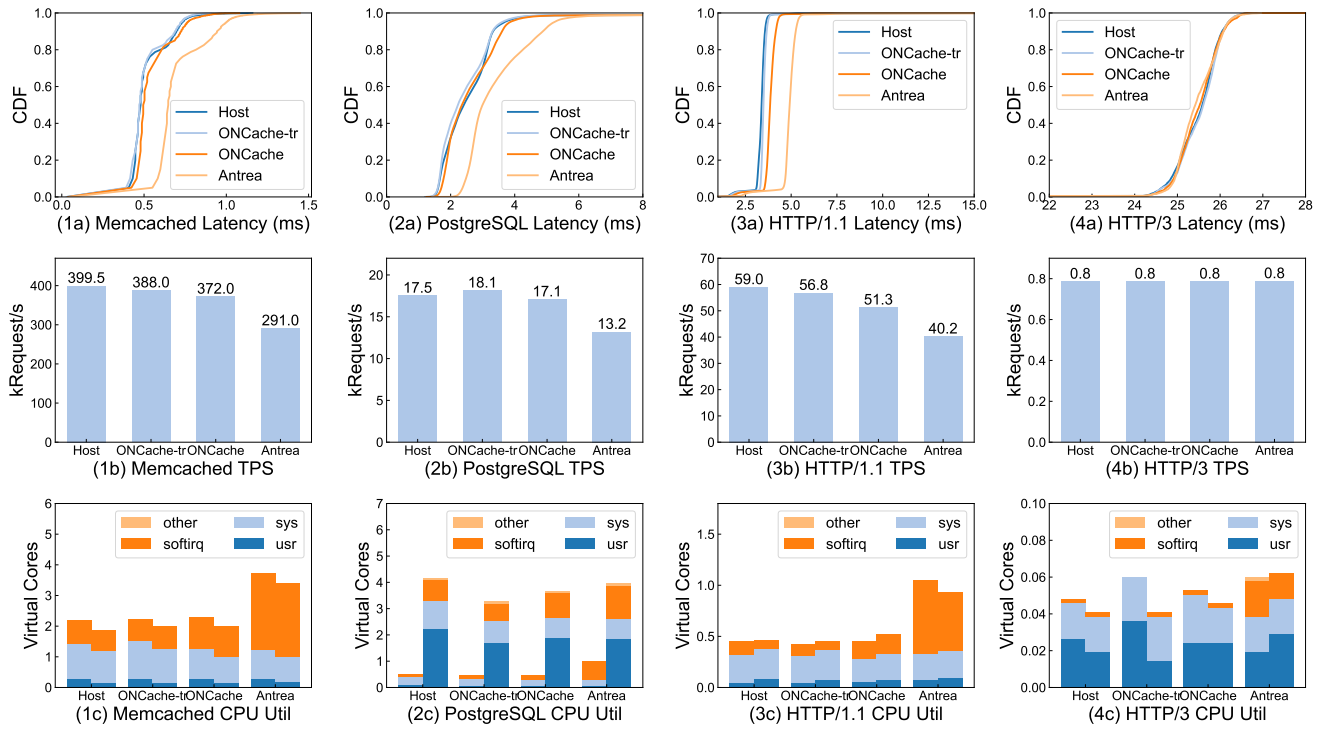

Figure 15: Application performance of Host, ONCache, ONCache with redirect rpeer and rewriting-based tunneling protocol (ONCache-t-r).