

Optimisation via encodings: a renormalisation group perspective

Konstantin Klemm

IFISC (CSIC-UIB), Campus Universitat de les Illes Balears, E-07122 Palma de Mallorca, Spain

E-mail: klemm@ifisc.uib-csic.es

Anita Mehta

Bioinformatics Group, Department of Computer Science and Interdisciplinary Center for Bioinformatics, University Leipzig, D-04107 Leipzig, Germany

Faculty of Linguistics, Philology and Phonetics, Clarendon Institute, Walton Street, Oxford OX1 2HG, UK

Max Planck Institute for Mathematics in the Sciences, Inselstrasse 22, D-04103 Leipzig, Germany

E-mail: anita@bioinf.uni-leipzig.de

Peter F. Stadler

Bioinformatics Group, Department of Computer Science and Interdisciplinary Center for Bioinformatics, University Leipzig, D-04107 Leipzig, Germany

Max Planck Institute for Mathematics in the Sciences, Inselstrasse 22, D-04103 Leipzig, Germany

Santa Fe Institute, Santa Fe, NM 87501, USA

E-mail: studla@bioinf.uni-leipzig.de

Abstract. Difficult, in particular NP-complete, optimization problems are traditionally solved approximately using search heuristics. These are usually slowed down by the rugged landscapes encountered, because local minima arrest the search process. Cover-encoding maps were devised to circumvent this problem by transforming the original landscape to one that is free of local minima and enriched in near-optimal solutions. By definition, these involve the mapping of the original (larger) search space into smaller subspaces, by processes that typically amount to a form of coarse-graining. In this paper, we explore the details of this coarse-graining using formal arguments, as well as concrete examples of cover-encoding maps, that are investigated analytically as well as computationally. Our results strongly suggest that the coarse-graining involved in cover-encoding maps bears a strong resemblance to that encountered in renormalisation group schemes. Given the apparently disparate nature of these two formalisms, these strong similarities are rather startling, and suggest deep mathematical underpinnings that await further exploration.

Published as J Phys A: Math Theor 56, 485001 (2023)

Keywords: coarse-graining, scale invariance, renormalisation groups, combinatorial optimization

1. Introduction

There has been a body of work on the optimisation of complex problems, in particular to do with NP-complete problems. These are typically approached by algorithms utilizing local search which, in analogy with the field of evolutionary biology, are often described as dynamics on a fitness landscape (see, e.g. the book by Engelbrecht and Richter [1]). The performance of local search algorithms depends strongly on the structure of the search spaces involved. These in turn are determined by two largely independent ingredients: (1) the concrete representations of the configurations that are to be optimized, referred to as encodings, and (2) locality in search space, usually determined by a move set.

For many well-studied combinatorial optimization problems and related models from statistical physics (such as spin glasses), there is a natural encoding. For instance, the tours of a Travelling Salesman Problem (TSP) are naturally encoded as permutations of the cities concerned, while spin configurations are encoded as strings over the alphabet $\{+, -\}$ with each letter referring to a fixed spin variable. This natural encoding is usually free of redundancy; any residual redundancies that occur usually arise from simple symmetries of the problem that can be factored out easily. For instance, tours in the Traveling Salesman Problem [2] can start at any city – therefore they are invariant under rotations. Many spin glass models are invariant under the simultaneous flipping of all spins.

For a given encoding, the performance of search crucially depends on the move set. Here, we will consider only reversible, mutation-like moves. The search space is therefore modeled as an undirected graph. The cost function assigned to a specific search space defines a *fitness landscape*. Evolutionary algorithms can thus be viewed as dynamical systems operating on landscapes, whose structure has, as a consequence, been studied extensively in the field [3, 4, 1].

Such approaches are however limited by the slowing down that occurs when the local minima that are a feature of the typically rugged landscapes encountered, arrest the progress of the search process. Another way of tackling optimization problems is by the use of heuristic approximations to estimate a global cost minimum. In [5], we presented a combination of these two approaches by using *cover-encoding maps*, which map processes from a larger search space to subsets of the original search space. The key idea was to construct cover-encoding maps, with the help of suitable heuristics, that singled out near-optimal solutions, and resulted in landscapes on the larger search space that no longer exhibited trapping local minima.

One of the features that emerged when this was done was that the maps typically involved a process of coarse-graining. Further considerations suggested that in fact there were striking similarities between these optimisation schemes and the schemes that are normally associated with the renormalisation group in physics.

The main aim of this paper is to use different examples of NP-complete problems to illustrate the analogies between the construction of our cover-encoding maps and the coarse-graining involved in renormalisation group schemes. The plan of our paper is as follows. In Section 2, we first revisit the basics of our theory of cover-encoding maps [5], with

particular reference to the Number-Partitioning Problem (NPP) which inspired it. We next use the quadratic spin glass to provide a concrete illustration of the coarse-graining inherent in the construction of cover-encoding maps, via detailed explorations which are analytical as well as computational. In Section 3, we move to the more formal aspects of the analogies between cover-encoding maps and renormalisation group schemes, involving a step-by-step comparison of their structure as well as their flow properties. In the Discussion section, we provide a succinct account of the similarities and differences between these two kinds of coarse-grainings, and discuss the open questions unravelled by our work.

2. Theory of cover-encoding maps: application to a quadratic spin glass

The initial motivation for the construction of cover-encoding maps was the decades-old observation that certain redundant encodings of the Number-Partitioning Problem (NPP) allow simple, generic optimization heuristics to find dramatically improved solutions [6]. In previous work [7] we found that this approach was not limited to the NPP, but that suitably chosen redundant encodings also improved the performance of heuristics on several other combinatorial optimization problems. In more recent work [5], we demonstrated (a) why the particular method used by [6] works so well and (b) how it can be generalized to arbitrary combinatorial optimization problems.

Our focus in [5] was on black-box-type optimization scenarios in which the information on the cost function $f(x)$ is exclusively obtained by evaluating it for specific configurations $x \in X$ in the search space X . The sequence of these function evaluations is determined by the optimization heuristic. Practical algorithms of this type propose candidates $x \in X$ for evaluation based on past evaluation results. These candidates are chosen locally in the vicinity of past successful candidates with the help of rules that depend on the representation of X . This explicitly or implicitly defines a topological structure on X . For the purpose of the present contribution, we assume that the topology of the search space X is expressed by a notion of adjacency that is respected by the search process.

Intuitively, the most important obstruction for local optimization heuristics is the presence of a large number of local optima that trap the search process. The aim of a redundant encoding, therefore, is to provide an alternative representation Y of the optimization problem that reduces the number of local optima and makes it easier to find the globally optimal solution. Such a formulation Y should, ideally, be such that:

- (i) neighborhoods in Y are small enough to be searched in practice.
- (ii) for every starting point there is a path to the global optimum such that the cost function is decreasing, or at least non-increasing.

Condition (i) ensures that we still deal with local search heuristics, while condition (ii) intuitively makes the landscape easy to search. Note that condition (ii) does not make the optimization problem trivial, since the heuristics still have to find an efficient path among possibly many very long ones. Its real significance is that it rules out traps and guarantees that simple downhill search will, eventually, be successful.

The implementation of the above conditions led to the construction of cover-encoding maps, whose theory will be presented in the next subsection.

2.1. General theory of Cover-encoding Maps

The key idea of cover-encodings is to replace the original optimization problem by a collection of “coarse-grained” optimization problems that collectively still cover all “relevant” solutions of the original problem. As we shall see below, the notion of coarse-graining a problem is intuitively appealing but difficult to grasp precisely in mathematical terms. Previously, we considered *restrictions* as an alternative [5]. As we shall argue, these restrictions can often (but not necessarily always) be chosen such that they conform to the idea of coarse-graining.

We choose the Number Partitioning Problem (NPP) [8] as a simple and instructive example of cover-encoding maps and coarse-graining. An NPP instance of size N is given by N positive numbers (a_1, a_2, \dots, a_N) . The optimization problem is to divide these numbers into two subsets such that the sums over subsets are as close as possible to each other. This amounts to finding a vector of \pm signs (or binary spins) $s = (s_1, s_2, \dots, s_N) \in \{-1, +1\}^N$ to minimize $f(x) = |\sum_{i=1}^n s_i a_i|$.

Cover encodings will be derived from restricted sets of solutions. For the NPP, a *prepartitioning* [6] assigns a cluster y_i to each index $i \in \{1, \dots, N\}$ such that a_i and a_j go into the same subset if i and j are in the same cluster. In terms of the sign vectors s , the prepartitioning restricts the solution space to the solutions with $s_i = s_j$ when $y_i = y_j$. Typically all cluster indices are chosen from the range $y_i \in \{1, 2, \dots, N\}$ allowing to express the unconstrained original problem by $y = (y_1, \dots, y_N) = (1, \dots, N)$ or a permutation thereof. As the other extreme, restriction to a single specific solution (s_1, \dots, s_N) is encoded by the prepartitioning with $y_i = 1$ for $s_i = -1$, and $y_i = 2$ for $s_i = +1$. The role of the prepartitioning algorithm is to enable global as well as local sampling: elements, be they distant or close on the original string, can be grouped together if they have the same prepartitioning index – a feature which is likely responsible [5] for the superior performance of this scheme compared to the others in [6].

The optimization problem in the solution space restricted by a prepartitioning y is again an instance of NPP, generally of smaller size N' and with transformed numbers. These are obtained by summing over the numbers in each non-empty cluster c , $a'_c = \sum_{\{i: y_i=c\}} a_i$. Thus y also defines a coarse-grained instance of NPP, whose input consists of one number for each class c of the partition y . The coarse-grained problem solves the original problem provided y is chosen so that it is a refinement of the optimal bipartition y^* that solves the NPP. Note that y^* is also a restriction of the original problem.

In the general case of a cost function $f : X \rightarrow \mathbb{R}$ over an arbitrary (finite) domain X , the analog of prepartitioning is to define a collection $\{\varphi(y) | y \in Y\}$ of subsets of X , where Y is a set of indices identifying the subsets. In the example of the prepartitions for the NPP, Y is the set all prepartitions, and for a prepartition $y \in Y$, $\varphi(y) \subseteq X$ specifies the subset of solutions defining prepartition y , and therefore also a particular coarse-graining of the original problem. The basic idea is now to replace the given search space X by the space Y of restrictions,

and to consider the collection of restricted problems $\hat{f}_y : \varphi(y) \rightarrow \mathbb{R}$ with $\hat{f}_y(x) = f(x)$ for all $x \in \varphi(y)$. In the example of prepartitions, we have $x \in \varphi(y)$ if and only if $x_i = x_j$ when $y_i = y_j$. In order to ensure that the collection of restricted problems still contains the ground state of the original problem, we require that $\bigcup_{y \in Y} \varphi(y) = X$, i.e., $\{\varphi(y) | y \in Y\}$ is a cover of X . The map $\varphi : Y \rightarrow 2^X$ that maps an “encoding” y to a subset $\varphi(y) \subseteq X$ is therefore called a *cover-encoding map* [5].

In order to explore the relationship between the cover-encoding map and the original optimization problem, we define the *oracle function*

$$F(y) := \min_{x \in \varphi(y)} f(x) \quad (1)$$

as the solution of each of the restricted optimization problems. Then $F : Y \rightarrow \mathbb{R}$ with $y \mapsto F(y)$ is again an optimization problem that has the same solution as the original problem, provided there is an encoding y^* with $\varphi(y^*) = \{x^*\}$ for the solution x^* of the original problem. As shown in [5], one can readily define a search operator (or neighborhood relations) on Y , such that the landscape $F : Y \rightarrow \mathbb{R}$ has no local optima, and also provided that adaptive walks exist to the solution y^* from every starting point $y_0 \in Y$.

Of course, computing F amounts to solving all restricted optimization problems and thus is essentially equivalent to computing a solution of the original problem. We can, however, *approximate* the oracle function by means of a heuristic G that produces a “good”, if not necessarily an exact, solution on $\varphi(y)$. In general, therefore we have $F(y) \leq G(y)$. Since the optimal solution x^* appears as an unambiguous encoding y^* with $\varphi(y^*) = \{x^*\}$ in the encoded landscape, we may assume that $G(y^*) = F(y^*)$, since this requires only that our heuristic correctly evaluate the fitness for a search space containing a single configuration. With the use of a heuristic for the restricted problems, we therefore obtain a fitness landscape of $G : Y \rightarrow \mathbb{R}$ whose global minimum identifies the global minimum of the original problem $f : X \rightarrow \mathbb{R}$. What we have gained, therefore, is that since G is an approximation to the oracle function F , it will also, at least approximately, have the desirable properties of F . In other words, we can expect to have a few shallow traps, and that “nearly” monotonic paths, from any starting point y_0 towards y^* , will exist.

We emphasise here that our focus is on a given instance, rather than, as in statistical mechanics, an ensemble (drawn from a probability distribution specified, for example, by the joint distribution of coupling constants). Another difference with typical situations in statistical mechanics is that we consider a fixed number n of entities (e.g. spins), and do not insist that this number tends to infinity.

In the next subsection, we provide a concrete illustration of the above ideas by using the example of a quadratic spin glass.

2.2. Coarse-graining spin glasses: analytical construction

In order to illustrate the link between cover-encoding maps and coarse-grained, smaller-sized problems, we consider the Hamiltonian of a quadratic spin glass

$$f(x) = \frac{1}{2} \sum_{i,j} a_{ij} x_i x_j + \sum_i b_i x_i \quad (2)$$

with $x_i = \pm 1$ and $1 \leq i, j \leq n$ with $a_{ij} = a_{ji}$. The diagonal terms are arbitrary and do not influence the ground state. At this point we make no assumptions on the coupling constants a_{ij} and b_i . Our aim here is to construct a simple generic coarse-graining scheme. In light of the previous section, we are in particular interested in a coarse-graining that causes only a small change in system size.

Most naturally, this is achieved by fixing the relative orientation of a pair k, l of spins. To expose their contribution, we partition f in the following form

$$f(x) = \frac{1}{2} \sum_{i,j \neq k,l} a_{ij} x_i x_j + \sum_{i \neq k,l} b_i x_i + \sum_{i \neq k,l} a_{ik} x_i x_k + \sum_{i \neq k,l} a_{il} x_i x_l + a_{kl} x_k x_l + b_k x_k + b_l x_l$$

Using $x_k^2 = 1$ we can rewrite the last terms as $\sum_{i \neq k,l} (a_{ik} + a_{il} x_k x_l) x_i x_k$ and $(b_k + b_l x_k x_l) x_k$. Depending on whether we fix x_k and x_l to be parallel or anti-parallel, we obtain two Hamiltonians

$$f_{kl}^{\pm}(x) = \frac{1}{2} \sum_{i,j \neq l} a_{ij}^{\pm} x_i x_j + \sum_{i \neq l} b_i^{\pm} x_i$$

with coupling constants that are modified exactly for the terms involving spin k . These now depend explicitly on the relative orientation of the spins k and l . For notational convenience, we represent the frozen spin-pair by the orientation of k . We have

$$a_{ki}^{\pm} = a_{ik}^{\pm} = a_{ik} + a_{il} x_k x_l \quad \text{and} \quad b_k^{\pm} = b_k + b_l x_k x_l \quad (3)$$

This leaves us with two choices to freeze the relative orientations of spins, $x_l := x_k$ or $x_l := -x_k$, resulting in two different Hamiltonians with $a_{ki}^+ = a_{ik} + a_{il}$, $b_k^+ = b_k + b_l + a_{kl}$ and $a_{ki}^- = a_{ik} - a_{il}$, $b_k^- = b_k - b_l - a_{kl}$, respectively. By construction we have $f(x) = f_{kl}^+(x) + a_{kl}$ if $x_k = x_l$ and $f(x) = f_{kl}^-(x) - a_{kl}$ if $x_k = -x_l$. We note for later reference that $b_i = 0$ for all i implies that the fields b_k^{\pm} also vanish in the modified problem. The constant terms $+a_{kl}$ or $-a_{kl}$ do not affect the ground state of each of the two smaller problems f_{kl}^+ or f_{kl}^- , one of which therefore retains the original ground state. A knowledge of the offset $\pm a_{kl}$ is necessary, however, to decide which of them contains the ground state, even given a knowledge of the ground states of the spin glass problems on $n - 1$ spin variables for the Hamiltonians f^+ and f^- respectively.

In terms of encodings, the fixing of orientations $x_l = x_k$ or $x_l = -x_k$ defines a partition of the original problem, which we may therefore see as two encodings y_{kl}^+ and y_{kl}^- with $\varphi(y_{kl}^+) = \{x \in X | x_l = x_k\}$ and $\varphi(y_{kl}^-) = \{x \in X | x_l = -x_k\}$.

The combination of coarse-graining steps of this type is not entirely trivial. Suppose we first freeze k, l and then h, k . This implies that the relative orientations of x_h and x_l are also

fixed. A convenient way to keep track of pairs of spins with fixed orientation is to encode this information in a spanning forest W . The connected components of W indicate the sets of spins that are frozen relative to each other. Each edge is labeled with $+$ or $-$ to indicate whether the adjacent spins are parallel or antiparallel. For two spins in the same connected component, the relative orientation is the product of the signs along the path connecting them. Given a spanning forest W on the set of spin variables with \pm -labeled edges, the relative signs of any two spins x_i and x_j in a connected component of W is given by the number of $-$ labels along the unique path from i to j in W : if there is an even number of $-$ labels, then $x_j = x_i$, if the number is odd then $x_j = -x_i$. As a consequence, we retain one independent spin z_c variable for each connected component c of W . Each encoding y , in this case, is defined by a \pm -labeled spanning forest on the spin variables. All interactions $a_{ij}x_ix_j$ within a connected component c become constant since x_ix_j equals either $x_c^2 = 1$ or $-x_c^2 = -1$. For every \pm -labeled spanning forest y , therefore, we obtain again a quadratic spin glass Hamiltonian f_y that differs from f by this additive factor. Every spin state z in the coarse-grained model together with the encoding y defines a spin state $x_y(z)$ in the original spin glass: To obtain x_i from z_c for a spin in connected component c of y , follow the path from the representative and account for the $-$ labels. Thus we have $f(x(z)) = f_y(z) + a_y$, where a_y is the extra additive constant accounting for the frozen interactions within each of the connected components. The Hamiltonian $f_y(z)$ is the coarse-grained spin glass, which is defined in terms of representative spin states z_c of the connected components c of W . Its ground state is $z^* = \arg \min_z f_y(z) = \arg \min_z f(x(z))$, where the second equality holds because a_y is a constant that, however, depends explicitly on the encoding y . The spin vector z^* can be translated back to the original system as follows: for each z , the \pm -labeled spanning tree W , i.e., the encoding y , uniquely determines the spin vector $x(z) \in \varphi(y)$. Therefore we can write the ground state of the original problem restricted to $\varphi(y)$ as $x^* := x(z^*) = \arg \min_{x \in \varphi(y)} f(x)$. Together, the coarse-grained spin glass models therefore determine the oracle function

$$F(y) = f(x^*) = f_y(z^*) + a_y. \quad (4)$$

While the constants a_y do not matter as far as the optimization on the coarse-grained Hamiltonians f_y is concerned, they cannot be neglected at the level of the oracle function, as well as its approximation in practical computations.

The spanning-forest-based construction outlined above can be specialized and further simplified in several ways. For example, the hierarchical block spin RG procedure [9] can be seen as a special case in which the only spanning forests considered are those whose connected components are blocks of spins with mutually frozen orientations. The hierarchical aggregation of blocks then corresponds to a hierarchy of spanning forests, with sub-forests which in turn correspond to finer aggregations.

2.3. Coarse-graining spin glasses: computational example of a spin glass encoding

As a case study, we consider a quadratic spin glass albeit with vanishing terms $b_i = 0$. We consider spins arranged on an $L \times L$ square grid with periodic boundary conditions. We label

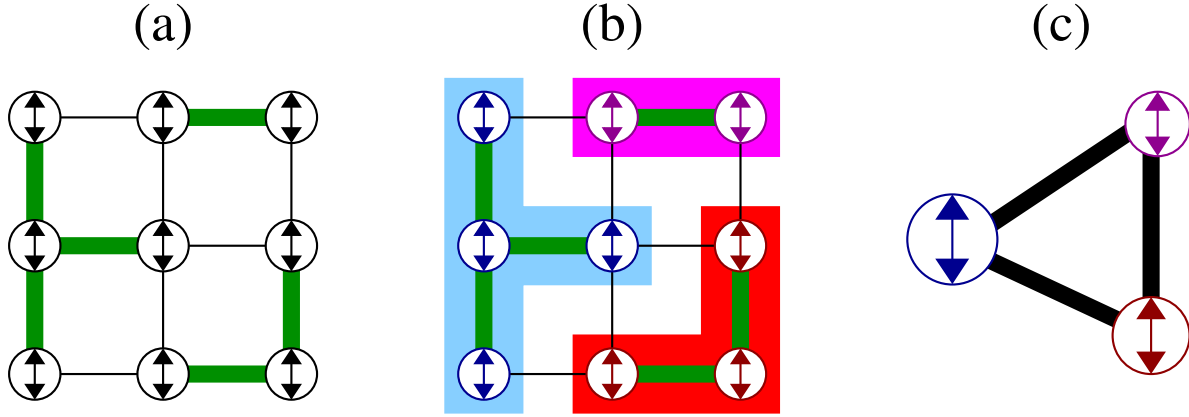

Figure 1. Illustration of the encoding by spanning forests on a spin glass system with 3×3 sites (circles with up-down arrows). (a) A spanning forest drawn with thick lines as a subset of the bond set. (b) Each connected component of the spanning forest induces a cluster (block) of spins, with blocks shown as shaded areas. (c) Mutual orientations of spins inside a block are fixed as parallel or antiparallel. Here, for simplicity and as done in the simulations, all edges of the forest are taken as labeled $+$. Spins inside a block are thus mutually parallel, combining into a single block spin each. At difference with the actual systems simulated, the square grid in this illustration is non-periodic.

the vertices $N_J = \{1, 2, \dots, N\}$ and write B for the bond set of this square grid. For sites $i, j \in N_J$, the initial coupling strength $a_{ij} \neq 0$ only if $\{i, j\} \in B$. Then $a_{ij} \in [-1; +1]$ is drawn uniformly and independently.

We use a variation of the encoding described in the previous section and lump together parallel spins only. Since the spanning forest itself serves as the encoding, we simply write y also for the spanning forest. Every connected component c of the spanning forest y , by assumption, satisfies $x_i = x_j = z_c$ for all $i, j \in c$. The set Y of encodings thus coincides with the set of (unlabeled) spanning forests. We note that two spanning forests y and y' with the same connected components satisfy $\varphi(y) = \varphi(y')$ and thus also $F(y) = F'(y)$. However, partitions and spanning forests suggest different move sets, i.e., neighborhood relations on Y . We also note that, for a given y , we have

$$\begin{aligned}
 f(x(z)) &= \sum_{c,d \in C_y, c \neq d} \underbrace{\left(\sum_{i \in c, j \in d} a_{ij} \right)}_{=: a_{cd}^{(y)}} z_c z_d + \underbrace{\left(\sum_{c \in C_y} \sum_{i, j \in c} a_{ij} \right)}_{=: \bar{a}_y} \\
 &= \sum_{c,d \in C_y} a_{cd}^{(y)} z_c z_d + \bar{a}_y = f_y(z) + \bar{a}_y
 \end{aligned} \tag{5}$$

Here, C_y denotes the set of connected components of the spanning forest y and z_c, z_d are the spin orientations for components c and d , respectively. Since all spins have the same orientation z_c within a component c , each component also contributes a constant. Each y , therefore, gives rise to a smaller quadratic spin glass problem $f_y(z)$ and an offset \bar{a}_y that accounts for the interactions within connected components.

As noted, the oracle function $F(y)$ cannot be computed efficiently in practice. We use the following procedure as a heuristic approximation to optimize the restricted problem $f_y(z) = \sum_{c,d} a_{c,d}^{(y)} z_c z_d$, i.e., to compute the approximation $G(y)$ of the oracle function $F(y)$.

Algorithm 1: Approximate Oracle Function $G(y)$

Data: $a_{c,d}^{(y)}$ for all connected components c, d of y

Initialize $a'_{c,d} \leftarrow a_{c,d}^{(y)}$ for all connected components c, d of y ;

while more than two spin variables (connected components) are left **do**

$\{p, q\} \leftarrow \arg \min a'_{p,q}$;

 unify components p and q ;

$a'_{r,p \cup q} \leftarrow a'_{r,p} + a'_{r,q}$;

end

$\hat{x} \leftarrow x(\hat{z})$ is the spin vector corresponding to the bipartition of N_J defined by \hat{z} on the remaining two connected components;

$G(y) \leftarrow f(\hat{x})$;

The idea behind this heuristic is that a bond with the largest (positive) coupling strength is likely to connect two spins with equal orientation in the ground state. The final ingredient is a move set on the forests. To this end we stipulate that two spanning forests are adjacent if they differ by a single edge. Note that insertion (or deletion) of an edge decreases (or increases) the number of connected components by one. Since both y and y' are spanning forests by assumption, only edges between connected components can be inserted.

Initialized with the empty forest $y(0) = \{\}$, an adaptive walk in the encoded landscape (Y, G) thus iterates the following operations. Draw $i, j \in N_J$ uniformly. If i and j are in different connected components of the forest $y(t)$, set $\tilde{y} = y(t) \cup \{\{i, j\}\}$; otherwise select an edge $\{k, l\} \in y(t)$ uniformly at random and set $\tilde{y} = y(t) \setminus \{\{i, j\}\}$; if $G(\tilde{y}) \leq G(y(t))$ set $y(t+1) = \tilde{y}$, otherwise set $y(t+1) = y(t)$. Thus in each time-step we generate a proposal \tilde{y} by random addition or removal of an edge; we accept \tilde{y} if, evaluated by G , it is not worse than the current solution $y(t)$.

For comparison, we consider adaptive walks on the direct landscape. Here we choose an initial spin vector by drawing $x(0)$ from $\{-1, 1\}^N$ uniformly. Then in each time step we perform the following operations in each time step. Generate a proposal \tilde{x} by flipping spin i in $x(t)$ with $i \in N_J$ selected uniformly at random. If $f(\tilde{x}) \leq f(x(t))$ set $x(t+1) = \tilde{x}$, otherwise set $x(t+1) = x(t)$.

Figure 2 shows that the adaptive walks in the encoding outperform those on the direct landscape after a sufficiently long time, $t \approx 10^5$. The heuristic alone without prepartitioning, however, performs worse than the adaptive walks on the direct landscape. This is different from the other encoding scenarios we have encountered so far [5]. For the number partitioning problem, for instance, the Karmarkar-Karp heuristic [10] alone outperforms the adaptive walks on the direct landscape. Here, the combination of the heuristic with the prepartitioning encoding is required for a performance gain.

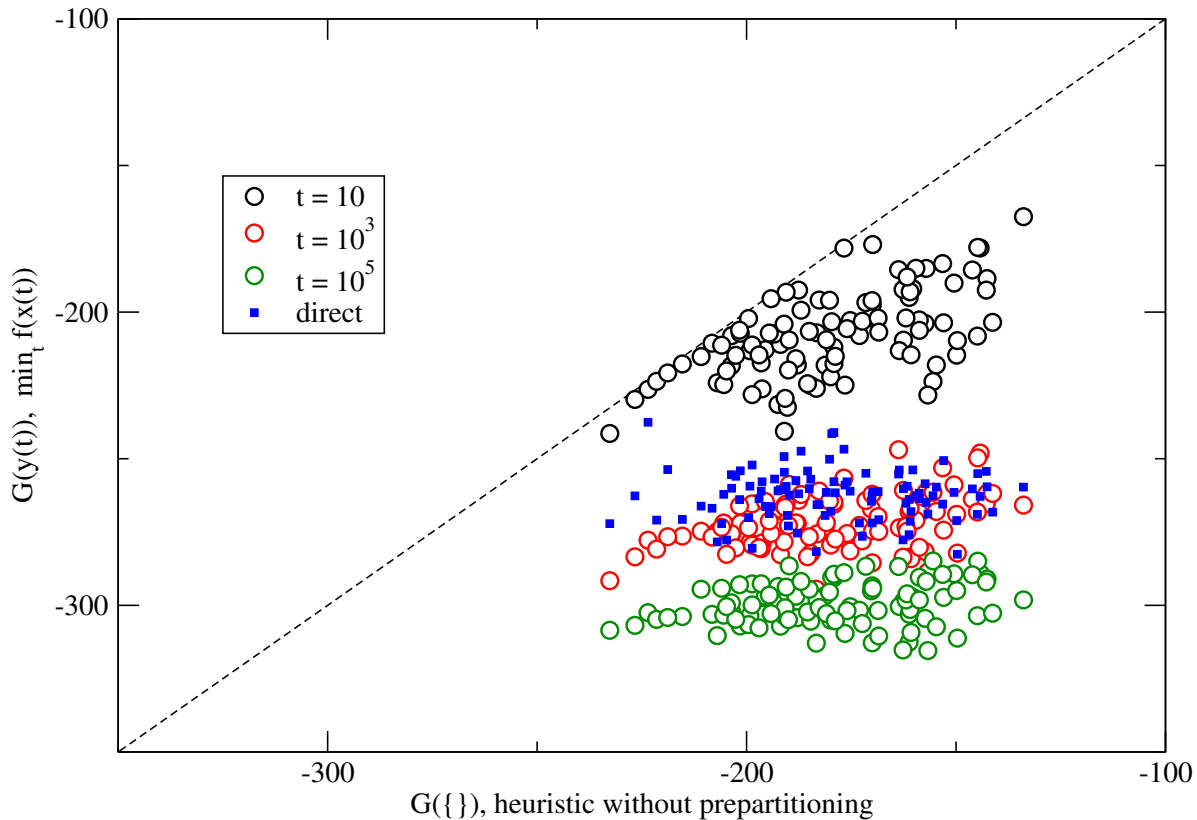

Figure 2. Results of adaptive walks on the landscapes of spin glasses on a 20×20 square grid. Each plotted point is the result of an adaptive walk on a randomly generated spin glass (see main text). Open circles show the value of the approximation $G(y(t))$ at times $t \in \{10, 10^3, 10^5\}$ versus $G(\{\})$, the value of the approximation without prepartitioning. Time t is measured in elementary updates of y , i.e. addition or removal of a single edge from the spanning forest. Each walk on the encoded landscape is initialized with the edge-less forest $y(0) = \{\}$, i.e., partitioning into singletons. For comparison, the minimum of the cost function $f(x(t))$ for $t \rightarrow \infty$ is shown for adaptive walks in direct encoding (filled squares) on the same spin glass instances.

In order to assess the significance of the performance gain observed in Figure 2, we compare the energy η_{\min} reached by an adaptive walk of length t in the encoded landscape $G : Y \rightarrow \mathbb{R}$ with the distribution of energy values E reached by a sample of adaptive walks with restart of the same length t in the direct landscape $f : X \rightarrow \mathbb{R}$.

Local search with restart serves as a heuristic solver for combinatorial optimization problems [11, 12]. After a given number of steps τ , the current solution is replaced by a spin configuration (x_1, \dots, x_N) drawn uniformly at random and the walk is continued from there. With total run time t being a multiple of τ , this amounts to independently running t/τ adaptive walks from different initial conditions and observing the overall minimum energy η_{\min} encountered.

In this setting, the empirical p-value for an improved performance of the encoding is simply the fraction of direct adaptive walks reaching $E \leq \eta_{\min}$. Figure 3 summarizes the results for the single spin-flip landscape for multiple spin-glass realizations (to estimate the

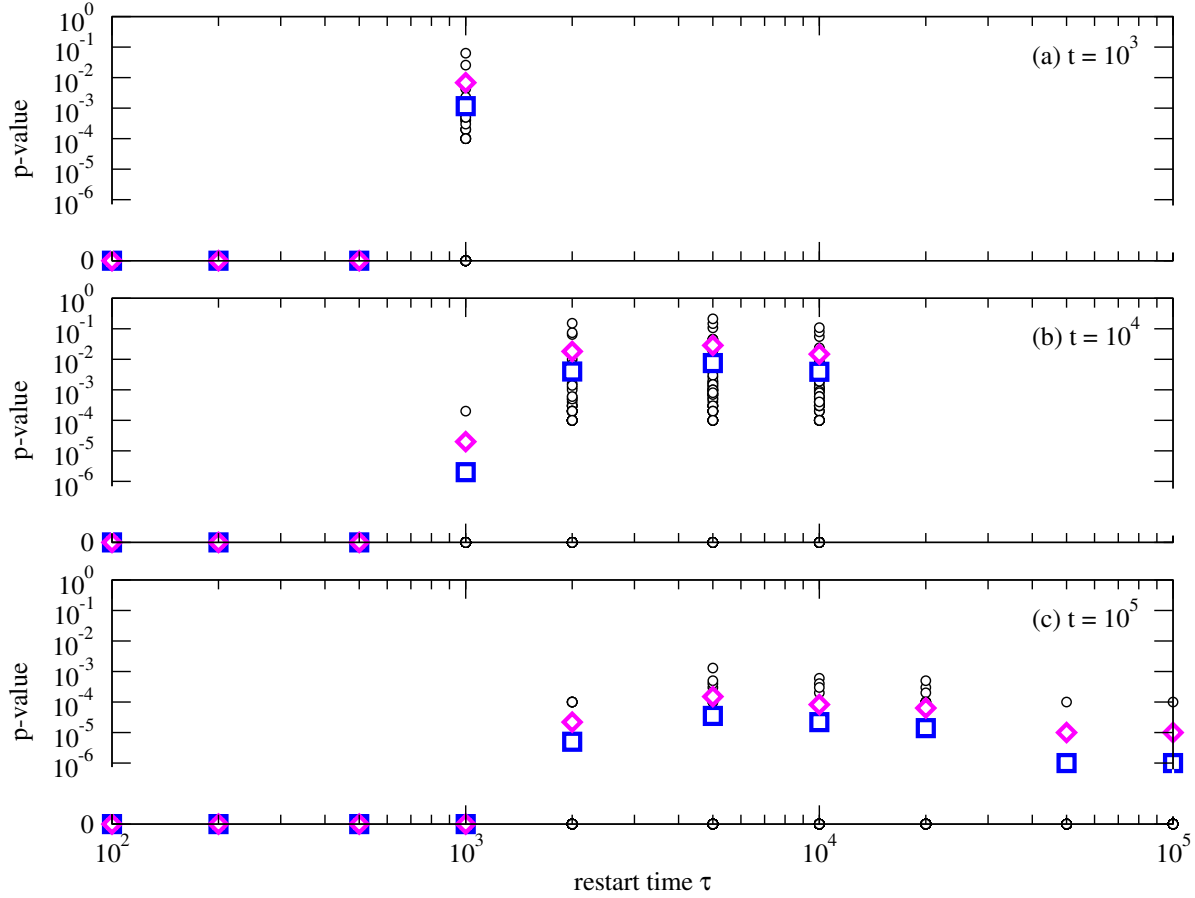

Figure 3. Performance statistics on 100 randomly generated spin glasses with 20×20 sites (same as in Figure 2). On each encoded landscape, a single adaptive walk of t steps is performed with the resulting minimum energy denoted by η_{\min} . The p-value (plotted as small circle) is the fraction of adaptive walks with restart in the direct (single spin-flip) landscape encountering an energy value $E \leq \eta_{\min}$, also within t steps. The mean (squares) and standard deviation (diamonds) over the 100 spin-glass realizations are shown for walk lengths $t \in \{10^3, 10^4, 10^5\}$ and restart time $\tau \leq t$. Each p-value is based on 10000 adaptive walks with restart in the direct landscape. The ordinate axes is split into a part with logarithmic scale and a part displaying the value zero.

variance) and different walk lengths $t \in \{10^3, 10^4, 10^5\}$ (panels (a), (b), (c)) and restart time $\tau \leq t$. The majority of p-values are very small, and decrease as the walk length increases. For walk length 10^5 , panel (c), all p-values are below 2×10^{-3} . We conclude that the encoded walks outperform all direct walks in each spin glass.

We analyze the prepartitioning in terms of the distribution of connected component sizes as shown in Figure 4. Compared to random forests with the same number of edges and nodes, the prepartitions generated by the encoded adaptive walks have a lighter tail but exhibit an additional peak at larger cluster sizes. The inset of Figure 4 shows a salient difference between actual prepartitions and surrogate forests: In most instances of adaptive walks, the second largest cluster of the prepartitioning is roughly of the same size as the largest cluster, an effect not seen in the surrogate forests where the second largest cluster is of negligible size.

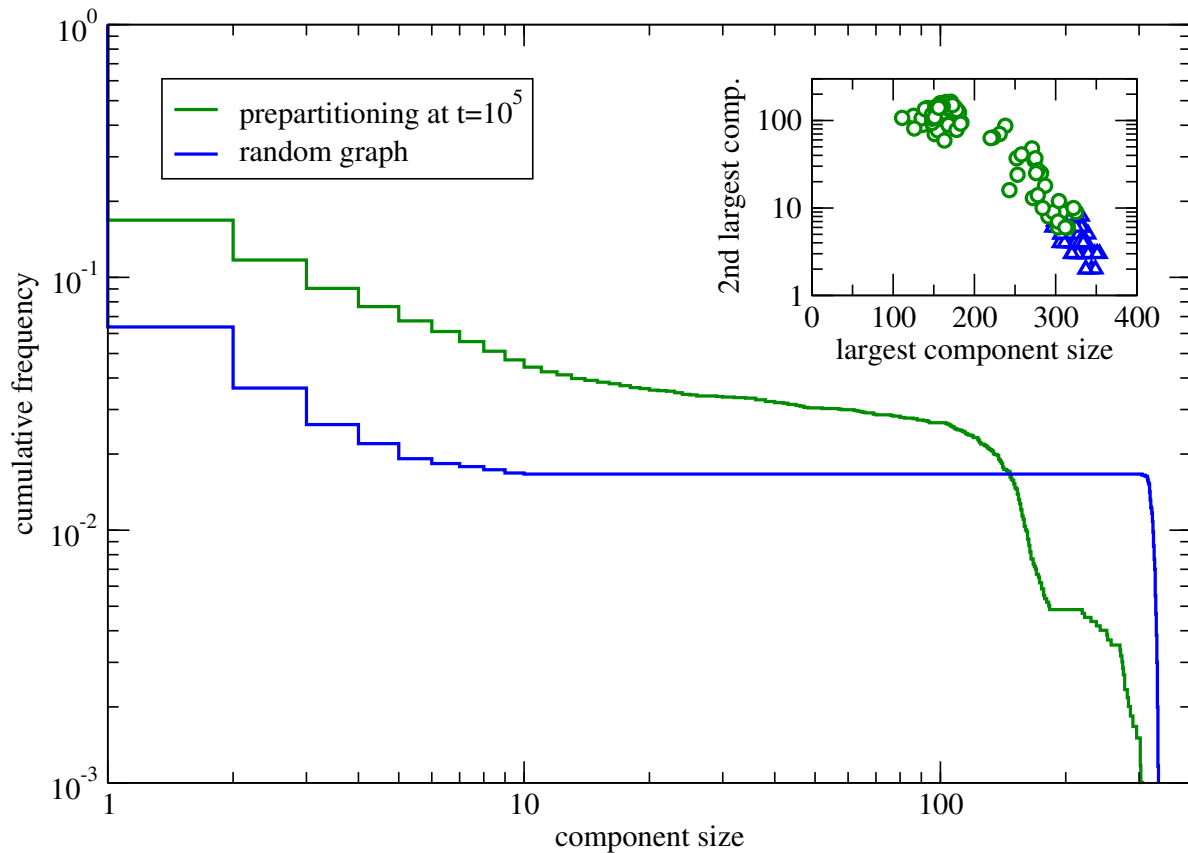

Figure 4. Main panel, green curve: cumulative distribution of cluster (connected component) sizes of adaptive walks in the encoded landscape at time $t = 10^5$, taken over the same 100 instances as in Figure 2. For surrogate spanning forests with the same number of nodes and edges, the blue curve is the cluster size distribution. In the inset, the largest vs. the second largest cluster size is shown for each of the 100 instances, again for the actual prepartitioning (green circles) and for random surrogate forests (blue triangles).

We end this section by considering the computational complexity of cost function evaluation. In the direct landscape, the cost function $f : X \rightarrow \mathbb{R}$ is a sum over $|B|$ terms, one for each bond of the spin glass. The time complexity of evaluating f is thus $\mathcal{O}(|B|)$. In an adaptive walk, however, only the difference of cost values between two spin configurations disagreeing at a single site i needs to be calculated. Then merely the terms for bonds incident on site i are evaluated which leads to constant time complexity $\mathcal{O}(1)$ if the number of neighbours is upper bounded independently of $|B|$. For the encoded landscape, evaluation of the cost function $G : Y \rightarrow \mathbb{R}$ has time complexity $\mathcal{O}(|B|)$ as well. This is due to the fact that each of the $|B|$ bonds is eliminated or lumped together with another bond at most once, either in the initial cluster formation by the prepartitioning, or in the heuristic Algorithm 1. Also here in the context of an adaptive walk, computing the cost difference between two adjacent encodings may require time scaling merely sublinearly with $|B|$ where details are subject to further analysis. The space complexity is $\mathcal{O}(1)$ for evaluating $f : X \rightarrow \mathbb{R}$ and $\mathcal{O}(|B|)$ for evaluating $G : Y \rightarrow \mathbb{R}$.

3. Formal analogies between cover encodings and the renormalisation group

3.1. Semigroup structure of cover-encodings

It is tempting to speculate that the coarse-grainings we have observed in the above are analogous to those observed in renormalization group theory, well known for its use in analyzing spin glasses and related disordered systems [13]. This intuition can be expressed more precisely as follows: For a given type of problem, such as the NPP or the TSP, consider the space \mathfrak{X} of all possible instances of all sizes. A particular instance is a point $\mathbf{x} \in \mathfrak{X}$. Now we define a set \mathcal{R} of maps $r : \mathfrak{X} \rightarrow \mathfrak{X}$ that map larger instances to strictly smaller ones. Of interest in this context are in particular those maps r that (approximately) preserve salient properties. Note that since $r(\mathbf{x})$ is a smaller instance than \mathbf{x} , the map r is not invertible – several larger instances can be coarse-grained to the same smaller one. Also, \mathcal{R} can be composed, (i.e., if $\mathbf{x}' = r_1(\mathbf{x})$ and $\mathbf{x}'' = r_2(\mathbf{x}')$, then $\mathbf{x}'' = r_2(r_1(\mathbf{x}))$), so that \mathbf{x}'' is a valid coarse-graining of \mathbf{x} . The coarse-grainings thus form a semi-group which is reminiscent of the *renormalization group* (RG) [14, 15].

As mentioned above, a technical problem arises from the innocuous-looking notion of “the space \mathfrak{X} of all possible instances of all sizes”. While this is harmless e.g. for the NPP, where a coarse-graining of an instance with n numbers, $\mathbf{x} = \{a_1, a_2, \dots, a_n\}$, is again an NPP on a smaller set of numbers that are partial sums of the original ones, problems can arise for other systems. Contracting a pair of spins in a lattice-based spin glass, for example, destroys the overall configuration; while $r(\mathbf{x})$ is a meaningful coarse-graining of \mathbf{x} , it no longer belongs to the problem class that we started with. This can be remedied in two ways: (i) we may restrict ourselves to coarse-grainings that guarantee $r(\mathbf{x}) \in \mathfrak{X}$ for all $\mathbf{x} \in \mathfrak{X}$ and all $r \in \mathcal{R}$, or (ii) we give up the notion of coarse-graining in the sense of creating a smaller problem instance, and instead consider coarse-graining as the imposition of restrictions on the solution space.

3.2. Cover-encodings viewed as generalized coarse-graining schemes

The coarse-graining scheme in Sect. 2.2 turned out to be closely related to the cover-encoding maps. The key observation for our purposes is that the restriction of f to $\varphi(y)$ serves as a slightly generalized version of the coarse-grained problem f_y . A series of additional examples of cover-encoding maps can be found in [5]. Some of these correspond to obvious coarse-graining schemes, while for others the cover-encoding leads to smaller instances of modified problems. The close relationship of cover-encoding maps to coarse-graining schemes, together with the technical difficulties arising from direct coarse-grainings, are reminiscent of the renormalisation group; we are thus prompted to explore analogies between cover-encoding maps and RG.

A simple example of cover-encoding maps are the so-called *schemata* [16], which are frequently used e.g., in the analysis of genetic algorithms. Assuming $X := \{0, 1\}^N$, the set of binary strings of length N , the corresponding schema encoding uses string $y \in \{0, 1, *\}^N =: Y$ as encoding variables. A string x belongs to the schema if y coincides with x on all fixed

positions, and has either a 0 or a 1 at the positions where y shows a wildcard character $*$. Thus

$$\varphi(y) = \{x \in X \mid x_i = y_i \text{ if } y_i \in \{0, 1\}\} \quad (6)$$

Note that $\varphi(y) = \{y\}$ if all positions in y are fixed, i.e., if y contains no wildcard, and $\varphi(y) = X$ if y consists of wildcards only. Schemata have been used for the RG analysis of models of genetic dynamics, see e.g. [17, 18, 19]. This connection provides yet another motivation to search for a possible connection between cover-encoding maps and RG formalisms.

The second key ingredient is the symmetric adjacency relation \sim on Y , which establishes a proximity relation on Y , the space of encoding variables. In [5] we defined \sim independently of φ . Nevertheless, the idea is that $y' \sim y''$ should be closely linked with properties of φ , i.e., $y' \sim y''$ should be true if $\varphi(y')$ and $\varphi(y'')$ are similar.

Moving from y' to an adjacent y'' may correspond to both coarse-graining and fine-graining. To introduce a directionality, we therefore need a measure for the number of degrees of freedom in $\varphi(y)$. For simplicity, we use here the cardinality $|\varphi(y)|$, but any measure $|\cdot|$ that is monotonic in the sense that $\varphi(y) \subsetneq \varphi(y')$ implies $|\varphi(y)| < |\varphi(y')|$ could be used. In the case of schemata, for example, the number of degrees of freedom is simply the number of wildcards, i.e., $\log_2 |\varphi(y)|$. In our spin glass example, the number of spin variables appearing in the Hamiltonian $f_y(z)$ is also $\log_2 |\varphi(y)|$. Similar monotonic relations hold for all examples described in [5].

Step-wise coarse-graining is thus achieved by moving from y' to an adjacent y'' such that $|\varphi(y')| \geq |\varphi(y'')|$. This turns (Y, \sim) into a directed graph $\Gamma(Y, E)$, replacing the undirected edges by a set E of arcs pointing towards neighbors with a non-increasing number of degrees of freedom. For technical reasons, we include equality here so as to connect more directly to the formalism of [5]. There, “sideways” steps were required in some examples to ensure the ergodicity of the neighborhood relation \sim .

3.3. The Flow Semigroup

In the digraph $\Gamma(Y, E)$ we consider, for every arc $e = (y, y') \in E$ the so-called *elementary collapsing map* [20, 21] defined by

$$T_e(v) = T_{(y, y')}(v) = \begin{cases} y' & \text{if } v = y \\ v & \text{otherwise} \end{cases} \quad (7)$$

That is, $T_{(y, y')}$ maps y to y' and leaves every other vertex invariant. Hence, T_e is idempotent, i.e., $T_e(T_e(v)) = T_e(v)$ for all $e \in E$. The elementary collapsing maps generate the transformation semigroup $\mathcal{S}(\Gamma) = \langle T_e \mid e \in E \rangle$ acting on Y , which is known as the *flow semigroup* or *Rhodes semigroup* of Γ [22]. It can be shown that $T_{(y, y')} \in \mathcal{S}(\Gamma)$ if and only if $(y, y') \in E$ or (y', y) is contained in a directed cycle of Γ [23]. The flow semigroup therefore completely determines the undirected graph underlying Γ [24, 22, 25]. The relationships between the properties of Γ and properties of $\mathcal{S}(\Gamma)$ are explored in some more detail in [26].

Now consider a function h on Y that is non-increasing along all edges of $G(Y, E)$. In particular, our measure for the degrees of freedom, i.e., $h : y \mapsto |\varphi(y)|$, has this property. Then

$h(T_e(v)) = h(y') \leq h(v)$ if $v = y$ since h is non-increasing along the directed edge (y, y') , and $h(T_e(v)) = h(v)$ otherwise. Any concatenation T of elementary collapsing maps, i.e., any $T \in \mathcal{S}(G)$ thus satisfies $h(T_e(v)) \leq h(v)$ for all $v \in Y$. The flow semigroup $\mathcal{S}(G)$ on $G(Y, E)$ therefore encapsulates a key property of the coarse-grainings: The action of every $T \in \mathcal{S}(G)$ on y produces an encoding Ty such that $|\varphi(Ty)| \leq |\varphi(y)|$, i.e., the number of degrees of freedom is non-increasing.

The semi-group formalism also provides a convenient way of expressing the reachability conditions imposed in [5]. Most naturally one would require:

(R) If $\varphi(y') \subseteq \varphi(y)$ then there is a $T \in \mathcal{S}(G)$ such that $y' = T(y)$.

Condition (R) simply says that whenever y' is a proper coarse-graining of y in the sense that y' encodes a restriction of $\varphi(y)$, then there is a directed path in $\Gamma(Y, E)$ from y to y' such that the number of degrees of freedom is non-increasing along the path. This interpretation follows directly from the definition of $\mathcal{S}(G)$ since $T \in \mathcal{S}(G)$ if and only if there is a sequence of edges e_1, \dots, e_k such that $T = T_{e_k}(T_{e_{k-1}}(\dots(T_2(T_1))\dots))$. In other words, condition (R) ensures that stepwise coarse-graining along the edges of $\Gamma(Y, E)$ can be concatenated in such a way that every proper coarse-graining can be achieved.

3.4. Overview of relationships with the renormalization group

Cover-encoding maps and the associated flow semigroup provide a useful *mathematical substrate* to construct, in a principled manner, coarse-graining schemes that may be amenable to RG analysis. However, the formalism does not provide in itself the quantities that are to be considered, i.e., those from which criticality conditions are derived.

It is interesting to note that cover-encoding maps can also be combined with coordinate transformations, i.e., bijective maps $\xi : X \rightarrow X'$. Instead of the original representation, one can first transform the given Hamiltonian/cost function to a different basis, and then construct a cover-encoding map for the transformed coordinate system. For the discrete models at hand, Walsh transformations [27] or the use of characters instead of group elements [28] are natural choices corresponding to discrete versions of Fourier transforms. Occasionally also other coordinate systems, e.g., Haar transforms, have been advocated in this context [29]. The possibility of making use of these types of coordinate transformations suggests that our cover-encoding framework may well be relatable to k -space RG.

As mentioned in a previous section, there is a major difference between the use of RG in statistical physics and the cover-encoding framework outlined above. While RG is primarily concerned with the rescaling of the distributions of observables in large systems to determine their critical behaviour, cover-encodings are largely concerned with single instances of arbitrary size. In practical applications, our flows on $\mathcal{S}(G)$ are determined by a stepwise decrease of $G(y)$, the approximation of the elusive oracle function, in the form of an adaptive walk. In the RG framework, by contrast, one considers continuous flows that can often be studied analytically.

This does not yet rule out an analogy, assuming that something like an ergodic hypothesis applies, where the behaviour of typical instances is indeed that of the average. Thus, starting

from $\mathbf{x} = (X, f)$, or more precisely, an encoding y so that $\varphi(y) = \mathbf{x}$, we can think of adjacent encodings $y' \sim y$ with $|\varphi(y')| < |\varphi(y)|$ as “renormalized” versions of $\varphi(y)$. A path in (Y, \sim) leading from \mathbf{x} to the trivial instance thus can be seen as the iteration of progressively renormalized samples.

A positive example of this analogy could be that of the spanning forest encoding of the NPP with real-space renormalization schemes for Ising spins: an example of an \mathcal{R} could be a so-called block spin transformation [9], where suitable averages are taken over small local subsets of spins, which are then progressively scaled up to larger system sizes to explore their critical behaviour. Only certain block variables will work for such schemes, depending on the underlying symmetries of the problem, just as, in the earlier subsection, only the sums of numbers a_i preserve the optimal solutions. Such simple real-space scalings, do not, however, always exist for our optimization schemes: the prepartition encoding of the TSP, for example, cannot be rephrased as a coarse-grained (i.e., reduced-size) TSP. To see this, simply observe that the evaluation of a tour in the restricted model still requires an optimization over multiple incoming and outgoing connections (roads) for every city, i.e., the information of inter-city distances cannot be collapsed in any way upon the transition from a larger (less restricted) to a smaller (more restricted) problem. This does not, however rule out the possibility of, say, a renormalisation-type scaling in some sort of generalised Fourier space. In the case of landscapes on permutation spaces, the characters of the symmetric group provide a suitable Fourier-like basis [28], which seem to be applicable to TSP and certain assignment problems.

4. Discussion

In this paper we have examined the ideas behind our cover-encoding schemes presented in [7, 5] to highlight the role of coarse-graining in them. The basic need for cover-encoding schemes arises because search algorithms typically encounter local minima in their quest for the perfect, globally optimal solution. The cover-encodings method of resolving this problem is to partition the search space (either in its original, or in a transformed, form) into segments (encodings), such that the set of these partitions also contains the globally optimal solution (i.e., so that the encodings are now cover-encodings). While an assumed ‘oracle’ is able to guide us to the perfect ground state, its elusiveness leads us into a process of educated guesswork, whereby we choose the best available “approximate oracle” that can guide us to the lowest energy states amenable to search in a reasonable time. In our earlier work [7, 5], we have given concrete examples of how to find and apply such approximate oracles to NP-complete problems.

We have also presented a study of the spin glass landscape encoded with prepartitioning by spanning forests. The heuristic employed is relatively inefficient in the sense of being outperformed by local search on the direct (single spin flip) landscape when applied alone, i.e. without prepartitioning. The scenario implies a performance ranking which is different from previous examples. The study [6] of the number partitioning problem with the largest differencing heuristic [10] and encoding by prepartitioning reveals a performance ranking:

$$\text{direct landscape search} < \text{heuristic} < \text{encoded landscape search}$$

For the spin glass encoding studied here, we observe that the prepartitioning evolves towards arranging the set of spins in two large clusters, that together nearly span the whole system, therefore being close to providing an actual solution. The heuristic is left with local processing, merging each of the remaining smaller clusters into one of the two large ones. A statistical comparison of the performance differences nearly unambiguously favours encoded adaptive walks over the direct landscape, suggesting suitable cover encodings as an appealing approach to algorithm design.

The main purpose of this contribution, however, is a better understanding of the similarity of cover-encoding schemes with those of the renormalisation group.

- Cover-encoding schemes can be used to provide (approximate) solutions of particular instances of problems. To this end, they require the approximate solution of a large number of (typically) smaller optimization problems. This is most useful if the original problem is NP-hard. Since computing the oracle function is (at least) as difficult as solving the original problem, the practical advantage derives from replacing $F(y)$ by an approximation $G(y)$ that can be computed more efficiently. Clearly, the use of cover-encodings makes no sense if $\min_{x \in X} f(x)$ can be computed efficiently. Similarly, while renormalization group schemes can be used for a wide range of systems, they are typically of the greatest interest for complex problems where exact solutions are unavailable; in these cases, RG is applied to provide approximate solutions of small and typical systems, with the understanding that these will be scalable to the thermodynamic limit. We have suggested that in the presence of ergodicity, the solution of "particular" instances in the cover-encoding optimisation schemes may be translatable to that of "typical" instances in statistical physics. We have also established that our cover-encoding schemes have the semigroup property, as is needed for a stricter analogy with renormalisation group schemes.
- The coarse-graining underlying our cover-encoding schemes can be applied, as shown in the body of the paper, to situations where degrees of freedom are progressively frozen out and replaced by far fewer "block" degrees of freedom, such as in the spanning forest encoding of the TSP. This is strongly analogous to the method of block spins in the renormalisation group [9]. Sometimes, however, the coarse-graining picture for our cover-encoding schemes is more subtle – it may not be in real space, but in some more complex space, e.g. as was seen in the prepartition approach to the TSP mentioned above. This bears at least a superficial resemblance to k -space renormalisation schemes, where it is difficult to visualise in real space the scale invariance between original and renormalised configurations.
- Essential features of the cover-encodings oracle [5] include a high degree of redundancy, an adjacency structure and a path to the global optimum. An interesting analogy in k -space RG concerns its smoothing schemes: faced by a divergence and/or a mismatch between original and effective variables, the path of an RG trajectory is re-defined on a smoother path to its fixed points using regularity schemes, or the ignoring of higher-order terms in Taylor expansions.

- Coping with strong disorder, in both cover-encoding as well as RG schemes, involves "averaging out" disorder; this is done in RG using, say, replica-symmetric (RSB) methods [30, 31], as well as being implicit in the choice of 'approximate' oracles for, say, the quadratic spin glass problem examined in the present paper.
- In both cover-encoding and RG methodologies, there is an element of choice involved: the wrong choice of trajectory in an RG scheme can get one to a trivial fixed point and equally, the wrong choice in an optimisation scheme can get one to a solution that is far from the optimal one. The choice of the correct trajectory is, in the case of optimisation schemes that are not fully analytic, based on trial and error and the use of computer algorithms; this is also the case for RG, where in [32], for example, the use of a greedy algorithm was combined with renormalisation group ideas to find an optimal solution to the TSP.

What we have presented above is a list of rather compelling analogies between optimisation schemes using cover-encodings, and those based on the ideas of the renormalisation group. These are not by any means complete. Questions regarding the details of the flow dynamics in both schemes remain. Let us assume that trivial/critical solutions in RG correspond to suboptimal/optimal solutions for encodings. In RG schemes, one assumes "linearisability"/smoothness around fixed points and the classification of adjoining trajectories as being stable or unstable. We await a more rigorous extension of such ideas to cover-encoding methods, which might make it easier to identify those paths that lead close to the global minimum.

We emphasise in conclusion that the analogies referred to above do not, in fact, address the most difficult enigma in either scheme: that of the choice of the appropriate encoding (cover-encoding schemes) or of the appropriate scaling method (RG schemes). In particular, we recall that of the four encodings applied to the Number Partitioning problem [6], the prepartitioning encoding turned out to be the most efficient; while this appears to be because of the introduction of diversity (involving the shuffling of numbers globally as well as locally), this has not been rigorously proven. In the same way, optimal RG schemes for complex systems involve methodologies that involve science as much as art in their choice. We hope that our present paper provides seed material for further investigations that may resolve these enigmas.

Acknowledgements

This work is supported in part by the European Research Council (ERC) under the European Union's Horizon 2020 research and innovation programme (grant agreement N. 694925) and the German Federal Ministry of Education and Research BMBF through DAAD project 57616814 (SECAI, School of Embedded Composite AI). KK acknowledges financial support from Project PID2021-122256NB-C22 funded by MCIN/AEI/10.13039/501100011033 / FEDER, UE.

References

- [1] Andries Engelbrecht and Hendrik Richter, editors. *Recent advances in the theory and application of fitness landscapes*. Springer-Verlag, Berlin, Heidelberg, 2014.
- [2] David L. Applegate, Robert M. Bixby, Vašek Chvátal, and William J. Cook. *The Traveling Salesman Problem: A Computational Study*. Princeton University Press, Princeton, NJ, 2006.
- [3] Christian M. Reidys and Peter F. Stadler. Combinatorial landscapes. *SIAM Review*, 44:3–54, 2002.
- [4] Bjørn Østman, Arend Hintze, and Christoph Adami. Critical properties of complex fitness landscapes. In Harold Fellermann, Mark Dörr, Martin M. Hanczyc, Lone Ladegaard Laursen, Sarah Elizabeth Maurer, Daniel Merkle, Pierre-Alain Monnard, Kasper Støy, and Steen Rasmussen, editors, *Artificial Life XII*, pages 126–132. MIT Press, 2010.
- [5] Konstantin Klemm, Anita Mehta, and Peter F. Stadler. Cover-encodings of fitness landscapes. *Bull. Math. Biol.*, 80:2154–2176, 2018.
- [6] W. Ruml, J. Ngo, J. Marks, and S. Shieber. Easily searched encodings for number partitioning. *J. Opt. Th. Appl.*, 89:251–291, 1996.
- [7] Konstantin Klemm, Anita Mehta, and Peter F. Stadler. Landscape encodings enhance optimization. *PLoS ONE*, 7:e34780, 2012.
- [8] M. R. Garey and D. S. Johnson. *Computers and Intractability. A Guide to the Theory of NP-Completeness*. W. H. Freeman, San Francisco, CA, 1979.
- [9] L. P. Kadanoff. Scaling laws for Ising models near t_c . *Physics Physique Fizika*, 2:263–272, 1966.
- [10] Narendra Karmarkar and Richard M. Karp. The differencing method of set partitioning. Technical Report UCB/CSD-83-113, EECS Department University of California, Berkeley, CA, 1983.
- [11] Bart Selman, Hector J. Levesque, and David G. Mitchell. A new method for solving hard satisfiability problems. In William R. Swartout, editor, *Proceedings of the 10th National Conference on Artificial Intelligence, San Jose, CA, USA, July 12-16, 1992*, pages 440–446, Washington, DC, 1992. AAAI Press.
- [12] Ole Jakob Mengshoel, David C. Wilkins, and Dan Roth. Initialization and restart in stochastic local search: Computing a most probable explanation in bayesian networks. *IEEE Trans. Knowledge Data Eng.*, 23:235–247, 2011.
- [13] Oliver J. Rosten. Fundamentals of the exact renormalization group. *Physics Reports*, 511:177–272, 2012.
- [14] K. G. Wilson and J. Kogut. The renormalization group and the ϵ expansion. *Phys. Rep.*, 12:75–199, 1974.
- [15] Kenneth G. Wilson. Renormalization group and critical phenomena. I. Renormalization group and the Kadanoff scaling picture. *Phys. Rev. B*, 4:3174–3183, 1971.
- [16] Lee Altenberg. The schema theorem and the Price’s theorem. In L. D. Whitley and M. D. Vose, editors, *Foundations of Genetic Algorithms 3*, pages 23–49, San Francisco CA, 1995. Morgan Kaufman.
- [17] Christopher R. Stephens. The renormalization group and the dynamics of genetic systems. *Acta Physica Slovaca*, 52:515–524, 2002.
- [18] Christopher R. Stephens, C Chryssomalakos, and Adolfo Zamora. Coarse graining in genetic dynamics: A renormalization group analysis of a simple genetic system. *Rev. Mexicana Fisica*, 50:388–396, 2004.
- [19] Christopher R. Stephens and Adolfo Zamora. Systematic approximations for genetic dynamics. *Adv. Complex Syst.*, 12:583–618, 2009.
- [20] J. M. Howie. The subsemigroup generated by the idempotents of a full transformation semigroup. *J. Lond. Math. Soc.*, 41:707–716, 1966.
- [21] J. M. Howie. Idempotent generators in finite full transformation semigroups. *Proc. R. Soc. Edinb.*, 81A:317–323, 1978.
- [22] John Rhodes. *Applications of Automata Theory and Algebra: Via the Mathematical Theory of Complexity to Biology, Physics, Psychology, Philosophy, and Games*. World Scientific, Singapore, 2010.
- [23] Xiuliang Yang and Haobo Yang. Maximal regular subsemibands of $Sign_n$. *Semigroup Forum*, 72:75–93, 2006.
- [24] Xiuliang Yang and Haobo Yang. Isomorphisms of transformation semigroups associated with simple digraphs. *Asian-European J. Math.*, 2:727–737, 2009.
- [25] Gábor Horváth, Chrystopher L. Nehaniv, and Károly Podolski. The maximal subgroups and the complexity

- of the flow semigroup of finite (di)graphs. *Int. J. Algebra Comput.*, 27, 2017.
- [26] James East, Maximilien Gadouleau, and James D. Mitchell. Structural aspects of semigroups based on digraphs. *Algebraic Combinatorics*, 2(5):711–733, 2019.
- [27] David E. Goldberg. Genetic algorithms and Walsh functions. Part I: a gentle introduction. *Complex Systems*, 3:129–152, 1989.
- [28] Dan Rockmore, Peter Kostelec, Wim Hordijk, and Peter F. Stadler. Fast Fourier Transform for fitness landscapes. *Appl. Comput. Harmonic Anal.*, 12:57–76, 2002.
- [29] Sami Khuri. Walsh and Haar functions in genetic algorithms. In *SAC '94: Proceedings of the 1994 ACM symposium on Applied Computing*, pages 201–205, New York, NY, 1994. ACM.
- [30] Marc Mézard, Giorgio Parisi, and Miguel A. Virasoro. *Spin Glass Theory and Beyond*. World Scientific, Singapore, 1987.
- [31] W. Barthel, A. K. Hartmann, M. Leone, F. Ricci-Tersenghi, M. Weigt, and R Zecchina. Hiding solutions in random satisfiability problems: A statistical mechanics approach. *Phys. Rev. Lett.*, 88:188701, 2002.
- [32] J. Houdayer and O. C. Martin. Renormalization for discrete optimization. *Phys. Rev. Lett.*, 83:1030–1033, 1999.