

GPU-Accelerated Matrix Cover Algorithm for Multiple Patterning Layout Decomposition

Guojin Chen¹, Haoyu Yang², and Bei Yu¹

¹The Chinese University of Hong Kong, NT, Hong Kong

²NVIDIA Corp.

ABSTRACT

Multiple patterning lithography (MPL) is regarded as one of the most promising ways of overcoming the resolution limitations of conventional optical lithography due to the delay of next-generation lithography technology. As the feature size continues to decrease, layout decomposition for multiple patterning lithography (MPLD) technology is becoming increasingly crucial for improving the manufacturability in advanced nodes. The decomposition process refers to assigning the layout features to different mask layers according to the design rules and density requirements. When the number of masks $k \geq 3$, the MPLD problems are \mathcal{NP} -hard and thus may suffer from runtime overhead for practical designs. However, the number of layout patterns is increasing exponentially in industrial layouts, which hinders the runtime performance of MPLD models. In this research, we substitute the CPU’s dance link data structure with parallel GPU matrix operations to accelerate the solution for exact cover-based MPLD algorithms. Experimental results demonstrate that our system is capable of full-scale, lightning-fast layout decomposition, which can achieve more than $10\times$ speed-up without quality degradation compared to state-of-the-art layout decomposition methods.

Keywords: Layout decomposition, CUDA, GPU

1. INTRODUCTION

The general process of MPLD is to assign the layout features close to each other into the different masks to enhance the lithography resolution since the features are far away enough to be printed with the existing lithography techniques. Previous literature generally models the MPLD to graph coloring problems and solves them using linear programming (LP) methods or variants. Unlike the classical coloring problems, the MPLD problems have their features. 1) The graph node representing the layout polygon can be split into multiple polygon segments, called stitch. 2) There are other rules beyond the widely adopted spacing constraint for the same color. Those constraints impose different challenges to the MPLD problems. Typically, MPLDs are formulated into mathematical optimization models, which can be roughly categorized into three types:¹ 1) integer linear programming (ILP) and its relaxation, 2) graph-based methods, 3) search-based approaches. Specifically, ILP for double patterning layout decomposition (DPLD)²⁻⁵ or triple patterning layout decomposition (TPLD).⁶⁻¹⁵ The relaxation techniques for ILP methods are well-researched due to the \mathcal{NP} -hardness of TPLD and QPLD.^{6,9,16,17} The graph feature of the input layout makes it natural to handle the MPLD with graph-theoretical algorithms, *e.g.*, the maximal-independent set (MIS),¹⁸ the shortest path.¹⁹ Another category is to use search-based algorithms following the divide-and-conquer principle, performing the search procedure on the sub-graphs.^{20,21} Nevertheless, graph coloring-based models encounter substantial obstacles when sophisticated rules are required. To address the intricate rules and density balance, exact cover(EC)-based MPLD models have been suggested.²²

Donald Knuth invented Algorithm X* to solve the EC problem and further suggested an efficient implementation technique called dancing links (DLX),²³ using doubly-linked circular lists to represent the matrix of the problem. Jiang and Chang²² designed a general and flexible MPLD framework based on augmenting DLX with LD task-related treatments, which can concurrently consider complex coloring rules and maintain density balancing. Li *et al.* presented OpenMPL,¹ an open-source LD framework, which introduced an improved flexible EC-based algorithm achieving better quality with a sacrifice in the runtime. However, this sacrifice in runtime is even more evident in the larger industrial designs, making the EC-based methods less practical when compared with ILP-based methods. With the increasing power of modern graphics processing units (GPUs), numerous

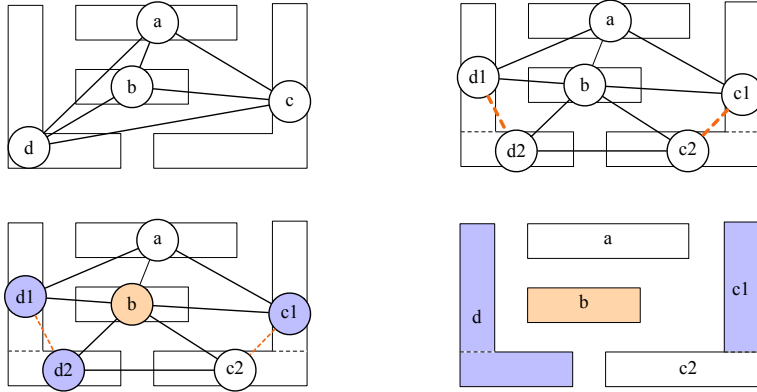

Figure 1: An example of TPLD with stitches. (a) The input layout consists of multiple polygons. (b) The layout graph (LG) construction process. The LG is 4-clique therefore not 3-colorable. (c) Stitches insertion process. Insert two stitches into the original LG to eliminate the 4-clique. (d) Decomposition process. The LG will be decomposed using a coloring solver with stitch candidate generation. The final layout will be decomposed into three masks colored with different colors.

successful applications use GPU to accelerate the design automation tasks, *e.g.*, mask optimization,^{24–29} design space exploration,^{30–33} and layout generation.^{34–36} Recent work pioneers using GPU and deep learning on pre or-post process of MPLD.^{37–40} However, the acceleration of the Layout decomposition algorithm itself has not been explored. It’s necessary to explore the GPU-accelerated EC-based methods for large industrial designs. In this paper, we propose a GPU-accelerated matrix cover algorithm for MPLD. Our main contributions are:

- We replace the CPU-based dancing link algorithms by leveraging the CUDA indexing model to solve the EC-based MPLD problems.
- We apply task parallelism to decompose the layout graph and improve the computation efficiency by parallel execution of CUDA kernel functions.
- We develop our GPU acceleration MPLD algorithms on top of the open-sourced decomposer OpenMPL¹ to ensure usability and scalability.

2. ALGORITHM

The detailed formulation of the MPLD problem is introduced in Section 2.1. Our algorithm is built on top of an open-sourced layout decomposer OpenMPL,¹ which implements various CPU-based MPLD methods. The decomposition flow is introduced in Section 2.2. As proposed in Section 2.3 We replace the decomposition solver with our GPU-accelerated matrix cover algorithm.

2.1 Problem formulation

As depicted in Figure 1, given an input layout specified by features in polygonal shapes, the layout can be translated into an undirected layout graph $G = \{V, E\}$, where every node $v_i \in V$ corresponds to one feature in layout and each edge $e_{ij} \in E$ is used to characterize the relationships between features. Considering conflict and stitch relationships, E is composed of these two kinds of edges, denoted by $E = \{CE \cup SE\}$, where SE is the set of stitch edges and CE is the set of conflict edges. The MPLD problem can be formulated as below:

$$\min_{\vec{x}} \sum c_{ij} + \alpha \sum s_{ij}, \quad (1a)$$

$$\text{s.t. } c_{ij} = (x_i == x_j), \quad \forall e_{ij} \in CE, \quad (1b)$$

$$s_{ij} = (x_i \neq x_j), \quad \forall e_{ij} \in SE, \quad (1c)$$

$$x_i \in \{0, 1, \dots, k\}, \quad \forall x_i \in \vec{x}, \quad (1d)$$

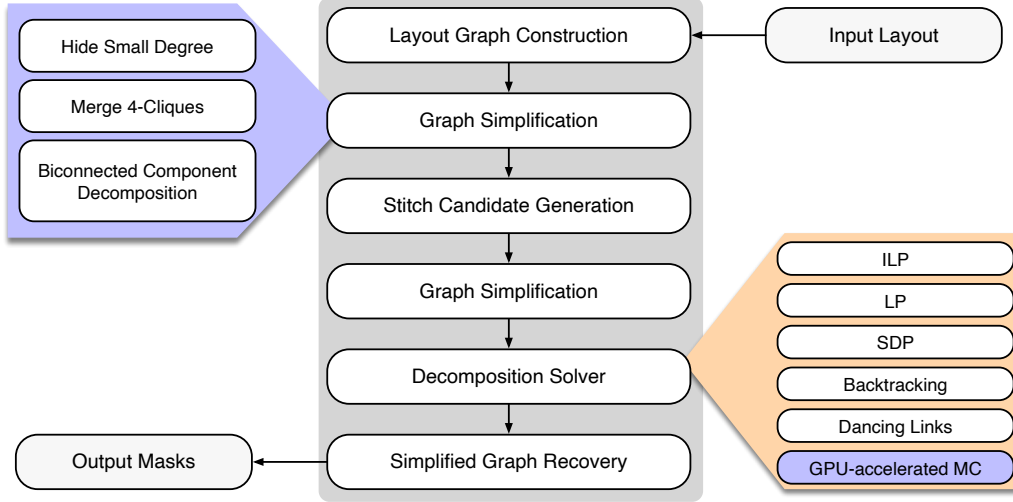

Figure 2: The overall flow for our framework, the coloring solver is replaced with our GPU-accelerated matrix cover solver.

where x_i is a variable for the k available colors of the pattern v_i , c_{ij} is a binary variable representing conflict edge $e_{ij} \in CE$, s_{ij} stands for stitch edge $e_{ij} \in SE$, α is a user-defined parameter and is set as 0.1 by default in our framework to assign relative importance between the conflict cost and the stitch cost. If two nodes, x_i and x_j , within the minimal coloring distance are assigned the same color (i.e. $x_i == x_j$), then $c_{ij} = 1$. On the contrary, $s_{ij} = 1$ when two nodes connected by stitch edge are assigned a different color (i.e. $x_i \neq x_j$). The objective function is to minimize the weighted summation of the conflict number and the stitch number.

2.2 The MPLD flow

As illustrated in Figure 2, we utilize a part of OpenMPL flow. The chip layout will be first transformed into a layout graph (LG) by a vector of rectangle pointers. The second step is to simplify the layout graph with stitch insertion, after which the layout graph will be decomposed into decomposed graph (DG) with stitches. Then we can call the graph coloring solver to solve the MPLD problems. As illustrated in Figure 2, in this step, we replace the EC-based solver with our GPU-accelerated matrix cover solver. Finally, the framework will recover the nodes removed in simplification step and assigns the coloring results from the coloring solver.

2.3 GPU-accelerated matrix cover for MPLD

The original EC-based algorithm²² models the MPLD as a matrix cover problem, as depicted in Figure 3. The input of the algorithm is a no-stitch graph $G_p = \{V_p, E_p\}$. Since G_p tends to be sparse, Knuth²³ suggested using DLX to solve it efficiently. The original layout will be transformed into a homogeneous graph and further translated into a binary matrix of “0”s and “1”s. Then the solution for the MPLD problem is transformed into solving the EC problem, which means finding a set of rows containing exactly one “1” in each column (Figure 3). The cover and uncover operations can be transformed into the removal and recovery of a doubly linked list,

$$\text{Cover} : L[R[x]] \rightarrow L[x], R[L[x]] \rightarrow R[x], \quad \text{Uncover} : L[R[x]] \rightarrow x, R[L[x]] \rightarrow x \quad (2)$$

where $L[x]$ and $R[x]$ point to the left and the right node of the linked list.

The hierarchical acceleration of GPU-based matrix cover solver is illustrated in Figure 4 and Algorithm 1. The three-dimensional indexing of CUDA programming model provides a natural way to index the matrix elements thus the DLX algorithm can be accelerated by GPU with the index x set as:

$$x = \text{blockIdx}.x \times \text{blockNum} + \text{threadIdx}.y \quad (3)$$

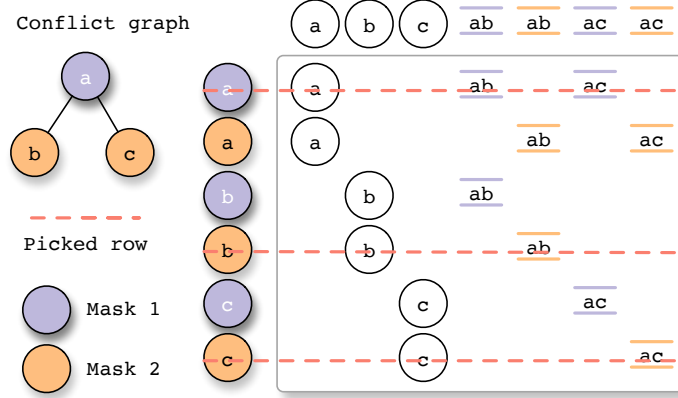

Figure 3: Exact cover matrix for double patterning layout decomposition with basic coloring rule.

where the *blockIdx* and the *threadIdx* are the indexer of CUDA programming model, the *blockNum* is a pre-defined hyperparameter indicating the degree of parallelism. As shown in Algorithm 1, the original DG will be decomposed into sub-graphs for acceleration (line 1 - line 3). Then the sub-graphs will be parallelly executed on different blocks (line 4) of a GPU to accelerate the DLX algorithm (line 4 - line 18). The *cover* and *uncover* operations in line 8 and line 16 are implemented as CUDA kernel functions *e.g.*, `delete_rows_and_columns`, `recover_results` and so on. As depicted in Figure 4, the kernel functions will be organized under the indexing and perform DLX in parallelization. Moreover, the shared memory of GPU is also used for global communication of different threads for further acceleration.

Algorithm 1 GPU-accelerated matrix cover algorithm

Require: Layout graph G and converted exact cover matrix M

Ensure: Colored graph and conflict features

```

1:  $graphID = blockIdx.x$ 
2:  $subgraphID = threadIdx.y$ 
3:  $idx = blockIdx.x * graph\_per\_block + subgraphID$ 
4: for each subgraph do
5:   if no column of  $idx$  remains or all columns of  $M$  are covered then
6:      $\lfloor$  Return  $\triangleright$  The solution has been found.
7:   Select an uncovered column  $cl$  with only one related row or in BFS order of  $G$ 
8:   Cover  $cl(idx)$ 
9:   if no  $cl$ 's related rows remain then
10:     $\lfloor$  Mark  $(cl, cl')$  as one conflict candidate
11:     $\lfloor$  where  $cl'$ 's is the column that has covered final related row of  $cl$ 
12:   for each row  $rw$  related to  $cl$  do
13:      $\lfloor$  Include  $rw$  into the current solution
14:      $\lfloor$  Cover  $rw$  and its affected rows
15:      $\lfloor$  Call GPU-accelerated matrix cover with  $G$  and  $M$ 
16:      $\lfloor$  Uncover  $rw$  and its affected rows
17:      $\lfloor$  Exclude  $rw$  from the current solution
18:    $\lfloor$  Uncover  $cl$ 
19: Return

```

3. EXPERIMENTAL RESULTS

The framework is implemented in C++ on an Intel Core 2.9-GHz Linux machine with Nvidia GeForce RTX 2080 GPU and nvcc 11.0 compiler. Regarding kernel execution, we assign 32 threads per block with one block for each

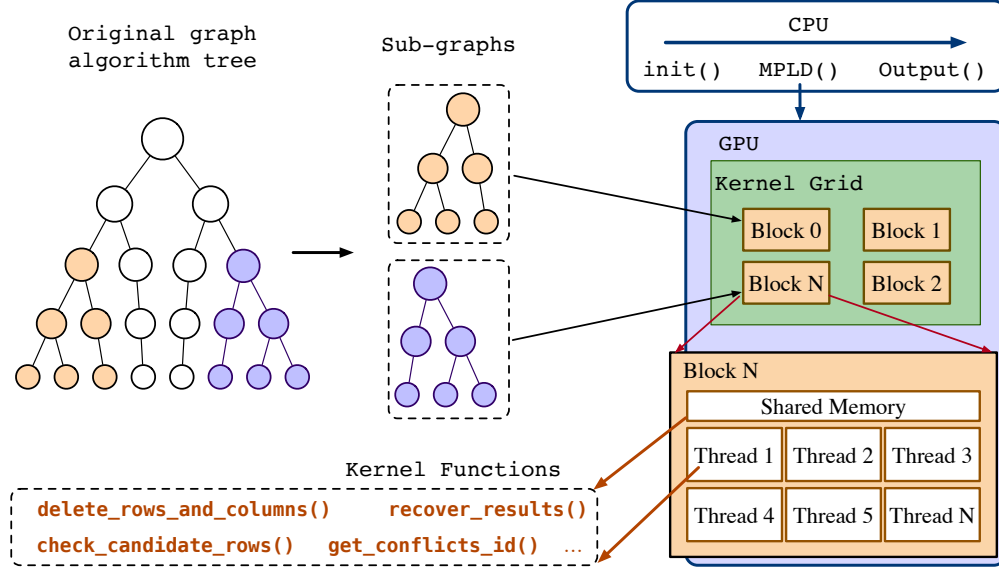

Figure 4: The hierarchical GPU acceleration model of our matrix cover algorithm.

Table 1: Result comparison with the state-of-the-art

Circuit	Graph Info		Original EC			OpenMPL EC			Ours		
	V	V	time(s)	st#	cn#	time(s)	st#	cn#	time(s)	st#	cn#
c432	1109	1222	0.005	4	0	0.008	4	0	0.000367	4	0
c499	2216	2817	0.004	0	0	0.006	0	0	0.000044	0	0
C880	2411	2686	0.005	7	0	0.007	7	0	0.000368	7	0
C1355	3262	3326	0.007	3	0	0.018	3	0	0.000767	3	0
C1908	5125	5598	0.008	1	0	0.022	1	0	0.001019	1	0
C2670	7933	9336	0.014	6	0	0.021	6	0	0.00085	6	0
C3540	10189	11968	0.029	8	1	0.035	8	1	0.006474	8	1
C5315	14603	16881	0.019	9	0	0.033	9	0	0.000511	9	0
C6288	14575	15605	0.114	203	8	0.142	204	1	0.007601	203	8
C7552	21253	24372	0.028	21	1	0.055	21	1	0.003175	21	1
S1488	4611	5504	0.008	2	0	0.007	2	0	0.000451	2	0
S38417	67696	79527	0.127	54	19	0.175	54	19	0.005955	54	19
S35932	157455	186052	0.286	48	44	0.299	40	44	0.018273	40	44
S38584	168319	196072	0.291	117	36	0.323	117	36	0.009688	117	36
S15850	159952	190796	0.285	100	34	0.342	100	34	0.014451	100	34
average	-	-	0.082	38.9	9.5	0.1	38.4	9.07	0.004666	38.3	9.5
ratio	-	-	1	1	1	1.2	0.99	0.95	0.0569	0.98	1

sub-graph. We compare our results with the original EC,²² OpenMPL EC¹ on ISCAS benchmarks. The ISCAS benchmarks are widely used in previous works. The minimum coloring spacing is set to 120 nm for the first ten cases and 100 nm for the last five cases, which are the same settings as,²² and.¹ We show the results in Table 1, where the “time(s)” column is the total simplification and decomposition time of graphs which have redundant stitches to be removed. The columns “st#” and “cn#” are the stitch and the conflict numbers. Compared with original EC, our GPU-accelerated solver can achieve $17.6 \times$ runtime speed-up with 2% fewer stitches. Compared with OpenMPL EC, our algorithm can achieve $20 \times$ speed-up and 1% fewer stitches with reasonable sacrifice on conflict number.

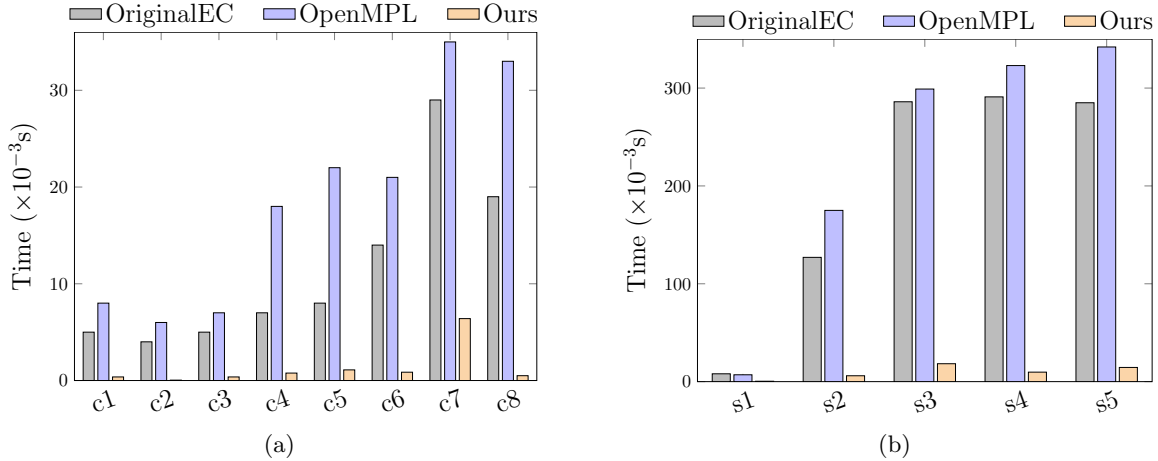

Figure 5: (a) The result comparisons on first ten smaller cases of ISCAS benchmarks. (a) The result comparisons on last five larger cases of ISCAS benchmarks.

4. CONCLUSION

In this paper, we propose a GPU-accelerated matrix cover algorithm for multiple patterning layout decomposition problems. Then we develop a set of GPU-efficient data structures and algorithms to accelerate the coloring process. We leverage the CUDA programming model to implement the DLX algorithm on GPU in parallelization. Compared with the state-of-the-art EC engine, our GPU-accelerated algorithm can achieve up to $17.6 \times$ speed-up on large designs.

REFERENCES

- [1] Li, W., Ma, Y., Sun, Q., Zhang, L., Lin, Y., Jiang, I. H.-R., Yu, B., and Pan, D. Z., “OpenMPL: An open-source layout decomposer,” *IEEE Transactions on Computer-Aided Design of Integrated Circuits and Systems* (2021).
- [2] Xu, Y. and Chu, C., “GREMA: graph reduction based efficient mask assignment for double patterning technology,” in [*IEEE/ACM International Conference on Computer-Aided Design (ICCAD)*], 601–606 (2009).
- [3] Kahng, A. B., Park, C.-H., Xu, X., and Yao, H., “Layout decomposition approaches for double patterning lithography,” *IEEE Transactions on Computer-Aided Design of Integrated Circuits and Systems (TCAD)* **29**, 939–952 (June 2010).
- [4] Yuan, K., Yang, J.-S., and Pan, D. Z., “Double patterning layout decomposition for simultaneous conflict and stitch minimization,” *IEEE Transactions on Computer-Aided Design of Integrated Circuits and Systems (TCAD)* **29**, 185–196 (Feb. 2010).
- [5] Gao, J.-R., Yu, B., and Pan, D. Z., “Self-aligned double patterning layout decomposition with complementary e-beam lithography,” in [*IEEE/ACM Asia and South Pacific Design Automation Conference (ASP-DAC)*], 143–148 (Jan 2014).
- [6] Yu, B., Yuan, K., Ding, D., and Pan, D. Z., “Layout decomposition for triple patterning lithography,” *IEEE Transactions on Computer-Aided Design of Integrated Circuits and Systems (TCAD)* **34**, 433–446 (March 2015).
- [7] Yu, B., Lin, Y.-H., Luk-Pat, G., Ding, D., Lucas, K., and Pan, D. Z., “A high-performance triple patterning layout decomposer with balanced density,” in [*IEEE/ACM International Conference on Computer-Aided Design (ICCAD)*], 163–169 (2013).
- [8] Yu, B., Roy, S., Gao, J.-R., and Pan, D. Z., “Triple patterning lithography layout decomposition using end-cutting,” *Journal of Micro/Nanolithography, MEMS, and MOEMS (JM3)* **14**(1), 011002–011002 (2015).
- [9] Lin, Y., Xu, X., Yu, B., Baldick, R., and Pan, D. Z., “Triple/quadruple patterning layout decomposition via linear programming and iterative rounding,” *Journal of Micro/Nanolithography, MEMS, and MOEMS (JM3)* **16**(2) (2017).

- [10] Lin, Y., Xu, X., Yu, B., Baldick, R., and Pan, D. Z., “Triple/quadruple patterning layout decomposition via novel linear programming and iterative rounding,” in [*SPIE Advanced Lithography*], **9781** (2016).
- [11] Yu, B., Yuan, K., Zhang, B., Ding, D., and Pan, D. Z., “Layout decomposition for triple patterning lithography,” in [*IEEE/ACM International Conference on Computer-Aided Design (ICCAD)*], 1–8 (2011).
- [12] Yu, B., Gao, J.-R., and Pan, D. Z., “Triple patterning lithography (TPL) layout decomposition using end-cutting,” in [*Proceedings of SPIE*], **8684** (2013).
- [13] Yu, B. and Pan, D. Z., “Layout decomposition for quadruple patterning lithography and beyond,” in [*ACM/IEEE Design Automation Conference (DAC)*], 53:1–53:6 (2014).
- [14] Lucas, K., Cork, C., Yu, B., Luk-Pat, G., Painter, B., and Pan, D. Z., “Implications of triple patterning for 14 nm node design and patterning,” in [*Proceedings of SPIE*], **8327** (2012).
- [15] Yu, B., Garretton, G., and Pan, D. Z., “Layout compliance for triple patterning lithography: an iterative approach,” in [*Proceedings of SPIE*], **9235** (2014).
- [16] Li, X., Zhu, Z., and Zhu, W., “Discrete relaxation method for triple patterning lithography layout decomposition,” *IEEE Transactions on Computers* **66**(2), 285–298 (2017).
- [17] Pan, D. Z., Liebmann, L., Yu, B., Xu, X., and Lin, Y., “Pushing multiple patterning in sub-10nm: Are we ready?,” in [*ACM/IEEE Design Automation Conference (DAC)*], 197:1–197:6 (2015).
- [18] Fang, S.-Y., Chen, W.-Y., and Chang, Y.-W., “A novel layout decomposition algorithm for triple patterning lithography,” in [*ACM/IEEE Design Automation Conference (DAC)*], 1185–1190 (2012).
- [19] Tian, H., Zhang, H., Ma, Q., Xiao, Z., and Wong, M. D. F., “A polynomial time triple patterning algorithm for cell based row-structure layout,” in [*IEEE/ACM International Conference on Computer-Aided Design (ICCAD)*], 57–64 (2012).
- [20] Kuang, J. and Young, E. F. Y., “An efficient layout decomposition approach for triple patterning lithography,” in [*ACM/IEEE Design Automation Conference (DAC)*], 69:1–69:6 (2013).
- [21] Chang, H.-Y. and Jiang, I. H.-R., “Multiple patterning layout decomposition considering complex coloring rules,” in [*ACM/IEEE Design Automation Conference (DAC)*], 40:1–40:6 (2016).
- [22] Jiang, I. H.-R. and Chang, H.-Y., “Multiple patterning layout decomposition considering complex coloring rules and density balancing,” *IEEE Transactions on Computer-Aided Design of Integrated Circuits and Systems (TCAD)* **36**(12), 2080–2092 (2017).
- [23] Knuth, D. E., “Dancing links,” (2000).
- [24] Chen, G., Yu, Z., Liu, H., Ma, Y., and Yu, B., “DevelSet: Deep neural level set for instant mask optimization,” in [*IEEE/ACM International Conference on Computer-Aided Design (ICCAD)*], (2021).
- [25] Yu, Z., Chen, G., Ma, Y., and Yu, B., “A GPU-enabled level set method for mask optimization,” in [*IEEE/ACM Proceedings Design, Automation and Test in Europe (DATE)*], (2021).
- [26] Chen, G., Chen, W., Ma, Y., Yang, H., and Yu, B., “DAMO: Deep agile mask optimization for full chip scale,” in [*IEEE/ACM International Conference on Computer-Aided Design (ICCAD)*], (2020).
- [27] Yang, H., Fung, K., Zhao, Y., Lin, Y., and Yu, B., “Mixed-Cell-Height legalization on cpu-gpu heterogeneous systems,” in [*IEEE/ACM Proceedings Design, Automation and Test in Europe (DATE)*], (2022).
- [28] Zhao, W., Yao, X., Yu, Z., Chen, G., Ma, Y., Yu, B., and Wong, M. D. F., “AdaOPC: A self-adaptive mask optimization framework for real design patterns,” in [*IEEE/ACM International Conference on Computer-Aided Design (ICCAD)*], (2022).
- [29] Geng, H., Zhong, W., Yang, H., Ma, Y., Mitra, J., and Yu, B., “Sraf insertion via supervised dictionary learning,” *IEEE Transactions on Computer-Aided Design of Integrated Circuits and Systems (TCAD)* (2020).
- [30] Geng, H., Chen, T., Ma, Y., Zhu, B., and Yu, B., “PTPT: Physical design tool parameter tuning via multi-objective bayesian optimization,” *IEEE Transactions on Computer-Aided Design of Integrated Circuits and Systems (TCAD)* (2023).
- [31] Geng, H., Ma, Y., Xu, Q., Miao, J., Roy, S., and Yu, B., “High-speed adder design space exploration via graph neural processes,” *IEEE Transactions on Computer-Aided Design of Integrated Circuits and Systems (TCAD)* (2022).

- [32] Chen, T., Duan, B., Sun, Q., Zhang, M., Li, G., Geng, H., Zhang, Q., and Yu, B., “An efficient sharing grouped convolution via bayesian learning,” *IEEE Transactions on Neural Networks and Learning Systems* (2022).
- [33] Geng, H., Yang, H., Zhang, L., Yang, F., Zeng, X., and Yu, B., “Hotspot detection via attention-based deep layout metric learning,” *IEEE Transactions on Computer-Aided Design of Integrated Circuits and Systems (TCAD)* (2022).
- [34] Wen, L., Zhu, Y., Ye, L., Chen, G., Yu, B., Liu, J., and Xu, C., “LayoutTransformer: Generating layout patterns with transformer via sequential pattern modeling,” in [*IEEE/ACM International Conference on Computer-Aided Design (ICCAD)*], (2022).
- [35] Yang, H., Pathak, P., Gennari, F., Lai, Y.-C., and Yu, B., “DeePattern: Layout pattern generation with transforming convolutional auto-encoder,” in [*ACM/IEEE Design Automation Conference (DAC)*], (2019).
- [36] Li, W., Chen, G., Yang, H., Chen, R., and Yu, B., “Learning point clouds in eda,” in [*Proceedings of the 2021 International Symposium on Physical Design*], (2021).
- [37] Ma, Y., Gao, J.-R., Kuang, J., Miao, J., and Yu, B., “A unified framework for simultaneous layout decomposition and mask optimization,” in [*IEEE/ACM International Conference on Computer-Aided Design (ICCAD)*], 81–88 (2017).
- [38] Zhong, W., Hu, S., Ma, Y., Yang, H., Ma, X., and Yu, B., “Deep learning-driven simultaneous layout decomposition and mask optimization,” in [*ACM/IEEE Design Automation Conference (DAC)*], (2020).
- [39] Li, W., Xia, J., Ma, Y., Li, J., Lin, Y., and Yu, B., “Adaptive layout decomposition with graph embedding neural networks,” in [*ACM/IEEE Design Automation Conference (DAC)*], (2020).
- [40] Ma, Y., Zeng, X., and Yu, B., “Methodologies for layout decomposition and mask optimization: A systematic review,” in [*IFIP/IEEE International Conference on Very Large Scale Integration (VLSI-SoC)*], 1–6 (2017).