

MetaTroll: Few-shot Detection of State-Sponsored Trolls with Transformer Adapters

Lin Tian
RMIT University
Melbourne, Australia
lin.tian2@student.rmit.edu.au

Xiuzhen Zhang
RMIT University
Melbourne, Australia
xiuzhen.zhang@rmit.edu.au

Jey Han Lau
The University of Melbourne
Melbourne, Australia
jeyhan.lau@gmail.com

ABSTRACT

State-sponsored trolls are the main actors of influence campaigns on social media and automatic troll detection is important to combat misinformation at scale. Existing troll detection models are developed based on training data for known campaigns (e.g. the influence campaign by Russia’s Internet Research Agency on the 2016 US Election), and they fall short when dealing with *novel* campaigns with new targets. We propose MetaTroll, a text-based troll detection model based on the meta-learning framework that enables high portability and parameter-efficient adaptation to new campaigns using only a handful of labelled samples for few-shot transfer. We introduce *campaign-specific* transformer adapters to MetaTroll to “memorise” campaign-specific knowledge so as to tackle catastrophic forgetting, where a model “forgets” how to detect trolls from older campaigns due to continual adaptation. Our experiments demonstrate that MetaTroll substantially outperforms baselines and state-of-the-art few-shot text classification models. Lastly, we explore simple approaches to extend MetaTroll to multilingual and multimodal detection. Source code for MetaTroll is available at: <https://github.com/ltian678/metatroll-code.git>

CCS CONCEPTS

• **Computing methodologies** → **Natural language processing**: *Information extraction*.

KEYWORDS

troll detection, few-shot learning, adapter, continual learning, multilingual, multimodal

ACM Reference Format:

Lin Tian, Xiuzhen Zhang, and Jey Han Lau. 2023. MetaTroll: Few-shot Detection of State-Sponsored Trolls with Transformer Adapters. In *Proceedings of the ACM Web Conference 2023 (WWW ’23)*, May 1–5, 2023, Austin, TX, USA. ACM, New York, NY, USA, 11 pages. <https://doi.org/10.1145/3543507.3583417>

1 INTRODUCTION

State-sponsored trolls, along with bots, are the main actors in influence operations and misinformation campaigns on social media.

Permission to make digital or hard copies of all or part of this work for personal or classroom use is granted without fee provided that copies are not made or distributed for profit or commercial advantage and that copies bear this notice and the full citation on the first page. Copyrights for components of this work owned by others than the author(s) must be honored. Abstracting with credit is permitted. To copy otherwise, or republish, to post on servers or to redistribute to lists, requires prior specific permission and/or a fee. Request permissions from permissions@acm.org.
WWW ’23, May 1–5, 2023, Austin, TX, USA

© 2023 Copyright held by the owner/author(s). Publication rights licensed to ACM.
ACM ISBN 978-1-4503-9416-1/23/04...\$15.00
<https://doi.org/10.1145/3543507.3583417>

The 2016 US Presidential election for example, highlighted how foreign states can carry out mass influence campaign, and in this case by Russia’s Internet Research Agency [40].¹ In another context, Broniatowski et al. [6] studied how influence operations undermined the vaccine debate in public health. To help combat misinformation on social media, Twitter began releasing user accounts associated with state-sponsored influence activities. Our work uses this dataset for troll detection, and as such a troll in our context is a state-sponsored agent with links to an influence campaign.

Existing troll detection models focus on extracting signals from user online posts and user activities [1–3, 8, 10, 12, 32]. Recent neural approaches explore fusing different feature representations for troll detection, e.g. social structure, source posts and propagated posts such as retweets on Twitter [3, 39]. These studies generally formulate the task as a standard supervised learning problem which requires a substantial amount of labelled data for known campaigns. As such, they are ill-equipped to detect novel campaigns sponsored by another state for a different target.

Meta-learning is a well-established framework for few-shot learning [14, 16, 28, 33, 35]. The idea of meta-learning is to leverage the shared knowledge from previous tasks to facilitate the learning of new tasks. In our context, meta-learning has the potential to quickly adapt a troll detection model to a new campaign via few-shot transfer, once it’s meta-trained on a set of known campaigns. However, in a continual learning setting where the troll detection model needs to be constantly updated to work with new campaigns over time, the standard meta-learning framework suffers from catastrophic forgetting – the problem where the model “forgets” how to detect trolls from the older campaigns as they are updated [36, 37].

The main contributions of this work are as follows:

- We introduce a troll detection problem under a realistic setting where novel campaigns continually emerge, mimicking real-world events on social media platforms.
- We propose MetaTroll, a text-based meta-learning framework for troll detection, which includes a three-stage meta-training process that allows it to learn knowledge across different campaigns for fast adaptation to new campaigns.
- MetaTroll tackles catastrophic forgetting by introducing *campaign-specific* transformer adapters [19] (i.e. each campaign has its own set of adapter parameters), which can “memorise” campaign-specific knowledge.
- MetaTroll has the ability to to work with multiple languages (multilingual) by using a pretrained multilingual model and incorporate images as an additional input (multimodal) by

¹<https://www.adelaide.edu.au/newsroom/news/list/2021/12/09/understanding-mass-influence-activities-is-critical>.

either encoding them using pretrained image classifiers or converting them into text via optical character recognition.

- Large-scale experiments on a real-world dataset of 14 Twitter campaigns showed the superior performance of MetaTroll.

2 RELATED WORK

Our related work comes from three areas, troll detection, meta-learning and few-shot text classification.

2.1 Troll detection

Early studies of troll detection focus on extracting hand-engineered features from the textual contents of user posts for troll detection [8, 10, 12, 12, 25, 31]. Signals such as writing style, sentiment as well as emotions have been explored [10, 31]. User online activities have also been used to detect trolls [8, 12]. Cheng et al. [8] presents a study on anti-social behavior in online discussion communities, focusing on users that will eventually be banned.

More recently, approaches that combine user posts and online activities for troll detection have emerged [1, 3, 4, 13, 20, 32, 34]. Addawood et al. [1] identify 49 linguistic markers of deception and measure their use by troll accounts. They show that such deceptive language cues can help to accurately identify trolls. Im et al. [20] propose a detection approach that relies on users' metadata, activity (e.g. number of shared links, retweets, mentions, etc.), and linguistic features to identify active trolls on Twitter. Shafiei and Dadlani [32] show that Russian trolls aim to hijack the political conversation to create distrust among different groups in the community. Stewart and Dawson [34] similarly demonstrate how trolls act to accentuate disagreement and sow division along divergent frames, and this is further validated by Dutt et al. [13] in relation to Russian ads on Facebook. In Badawy et al. [4], the authors study the effects of manipulation campaigns by analysing the accounts that endorsed trolls' activity on Twitter. They find that conservative-leaning users re-shared troll content 30 times more than liberal ones. Zannettou et al. [39] compare troll behavior with other (random) Twitter accounts by recognising the differences in the content they spread, the evolution of their accounts, and the strategies they adopted to increase their impact. Atanasov et al. [3] leverage both social structure and textual contents to learn user representations via graph embedding. We focus on how to detect trolls in emergent social activities with limited labelled data.

2.2 Meta-learning

Meta-learning aims to extract some transferable knowledge from a set of tasks to quickly adapt to a new task. These approaches can be divided into three categories: metric-based, optimisation-based, and model-based. Metric-based meta-learning approaches [33, 35] aim to learn an embedding function to encode the input and a metric function to learn the distance (e.g. cosine distance and euclidean distance) between the query data and support data. Optimisation-based approaches [14, 16] are designed to learn good parameter initialisation that can quickly adapt to new tasks within a few gradient descent steps. Model-based approaches [26, 30] use neural networks to embed task information and predict test examples conditioned on the task information. Our approach combines both optimisation and model-based ideas in that we adopt [14] to update

model parameters and a novel architecture that involves adapters and adaptive classification layers to learn task information.

2.3 Few-shot text classification

Text classification has shifted from task-specific training to pre-trained language models (such as BERT) followed by task-specific fine-tuning [11, 27]. Recently, the language model GPT-3 [7] has shown strong few-shot performance for many natural language processing tasks. Few-shot text classification refer to a text classification setting where there are novel unseen tasks (domains) with only a few labelled examples for training a classification model, and meta-learning have been shown to produce strong performance [5, 15, 17, 38]. Bao et al. [5] introduce distributional signatures, such as word frequency and information entropy, into a meta-learning framework. Gao et al. [15] combine attention mechanism with prototypical network to solve noisy few-shot relation classification task. Geng et al. [17] leverage the dynamic routing algorithm in meta-learning to solve sentiment and intent text classification tasks for English and Chinese datasets. Yu et al. [38] propose an adaptive metric-based method that can determine the best weighted combination automatically. In our problem setting, our focus is on adapting the classifier to a new task (i.e. campaign) under the meta-learning framework.

3 PROBLEM STATEMENT

We first explain some preliminaries of meta-learning, and contextualise it under our problem setting, before describing our model in Section 4. Let $\mathcal{E} = \{e_0, e_1, e_2, \dots, e_l\}$ be a set of campaigns. These campaigns are split into two partitions: \mathcal{E}_{train} for meta-training and \mathcal{E}_{test} for meta-testing (in our case, we have 6 campaigns for \mathcal{E}_{train} , and 4 for \mathcal{E}_{test} ; see Table 1). For each campaign e , we have labeled users \mathcal{U} , where each user \mathbf{u} consists of a list of text posts and images, defined as $\mathbf{u} = \{(c_0, m_0, p_0), \dots, (c_n, m_n, p_n)\}$, where c refers to the textual content of the post, m a set of images, and p the timestamp of the post. Each user \mathbf{u} is associated with a ground-truth label $y \in Y$, where Y represents the label set (troll or non-troll; binary). Our goal is to leverage the knowledge learned from past (meta-train) campaigns (\mathcal{E}_{train}) to adapt quickly to new (meta-test) campaigns (\mathcal{E}_{test}) via few-shot learning (e.g. 5 or 10 users for the new campaign).

In our problem setting, the notion of a task (from meta-learning) is the *binary troll detection task for a particular campaign*. Each task $\mathcal{T}_i = (\mathcal{D}^s, \mathcal{D}^q)$ includes a support set \mathcal{D}^s with S data points and a query set \mathcal{D}^q with Q data points, where $\mathcal{D}^s = \{\mathbf{u}_i^s, y_i^s\}_{i=1}^S$, $\mathcal{D}^q = \{\mathbf{u}_i^q, y_i^q\}_{i=1}^Q$, and \mathbf{u}_i is a user with a list of posts and images and $y_i \in \{0, 1\}$ corresponding to troll/non-troll labels (as defined above). During meta-training, we iterate through different campaign in \mathcal{E}_{train} and sample support and query instances to train the model. Once that's done, to adapt to a new campaigns in \mathcal{E}_{test} , we follow a similar training process but we update the model parameters using *only* the support instances from the new campaign, and reserve the query set for evaluation (i.e. the query set is not used for model update).

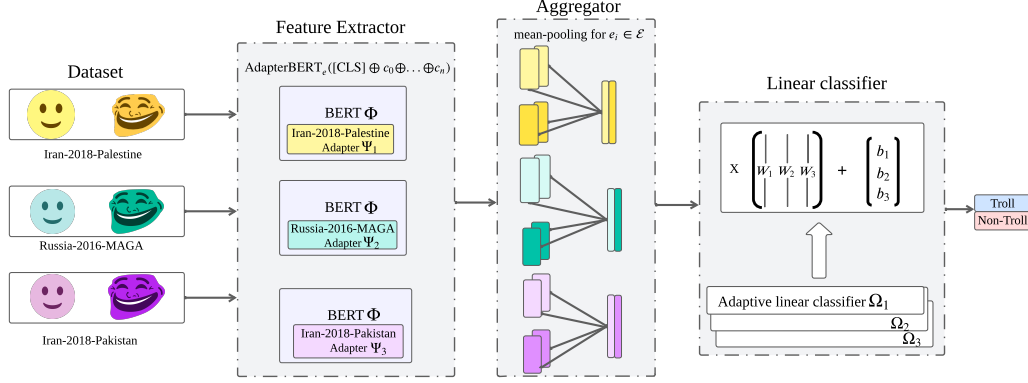

Figure 1: Overall architecture of MetaTroll.

4 APPROACH

We present the overall architecture of MetaTroll in Figure 1. MetaTroll has two modules, a BERT-based [11] feature extractor and an adaptive linear classifier.

We first explain at a high level how we train MetaTroll in three stages for the feature extractor and linear classifier (Algorithm 1). In the first stage, we fine-tune an off-the-shelf BERT and update all its parameters (Φ) using *all* training samples from the meta-train campaigns \mathcal{E}_{train} (line 1 in Algorithm 1). At this stage we do not introduce adapters [19] to BERT and it is optimised to do binary classification of trolls and non-trolls. The idea of this step is to train a feature extractor for the troll detection task (in other words, this step is standard fine-tuning to adapt BERT for binary troll detection).

In the second stage, we introduce adapters [19] to BERT and train the adapter parameters (Ψ) using model agnostic meta-learning (MAML: Finn et al. [14]; line 3–16 in Algorithm 1). Note that the adapter is *shared* across all campaigns (i.e. the adapter is *not* campaign-specific), and the idea of this stage is to learn a good initialisation for the adapter to do general troll detection; in the next stage, the learned adapter parameters will be used to initialise *campaign-specific* adapters. During this stage, only the adapter parameters (Ψ) are updated while the BERT parameters (Φ) are frozen.

In the third and final stage, we introduce campaign-specific adapters and adaptive linear classifiers to MetaTroll, creating the full model. The campaign-specific adapters are initialised using the campaign-general adapter from stage 2. The idea of using campaign-specific adapters is to address catastrophic forgetting when MetaTroll is continuously updated for new campaigns that emerge over time in an application setting: the campaign-specific adapter solves the ‘forgetting’ problem because the knowledge of detecting older/past campaigns are stored in their adapters which will not be overwritten as MetaTroll is continually updated. As for the adaptive linear classifiers, they are also campaign-specific and designed to encourage MetaTroll to learn campaign representations that are distinct for different campaigns.² We update the campaign-specific adapter (Ψ_e) and classifier parameters (Ω_e) via

²The adaptive linear classifier parameters are initialised randomly for a new campaign.

meta-learning, similar to stage 2 training (line 17–32 in Algorithm 1), noting that the BERT parameters (Φ) are frozen in this stage.

After MetaTroll is trained (over the 3 stages), to adapt it to trolls of a new campaign at test time, we follow the third stage training to learn campaign-specific adapter (Ψ_e) and classifier (Ω_e) parameters for the new campaign. Once adapted, MetaTroll can be used to classify users from this new campaign. We next describe the training stages and test inference in detail.

4.1 Stage One Training

In the first stage, MetaTroll is a standard BERT fine-tuned with standard cross entropy loss to do binary classification of trolls vs. non-trolls (ignoring the campaigns). Given a user u with posts $\{c_0, \dots, c_n\}$:

$$v = \text{BERT}([\text{CLS}] \oplus c_0 \oplus \dots \oplus c_n) \quad (1)$$

$$\hat{y} = \text{softmax}(Wv + b) \quad (2)$$

where v is the contextual embedding of [CLS] and \oplus is the concatenation operation.

4.2 Stage Two Training

In the second stage, we add adapters to BERT (see Figure 2). Following [19], we insert two adapter modules containing bottleneck layers into each transformer layer of BERT. Note that the adapter is *shared* across all campaigns here, as the goal in this stage is to learn good set of initial adapter parameter values that can be used to initialise campaign-specific adapters in the next stage.

Correspondingly, Equation 1 is now modified to:

$$v = \text{AdapterBERT}([\text{CLS}] \oplus c_0 \oplus \dots \oplus c_n) \quad (3)$$

We meta-train the adapter parameters using MAML (line 3–16 in Algorithm 1). We first sample a task \mathcal{T}_i for campaign e from \mathcal{E}_{train} to create the support D^s and query set D^q . Denoting M as the model, Φ the BERT parameters and Ψ the adapter parameters,

Algorithm 1 MetaTroll

Input/hyper-parameters: meta-train campaigns \mathcal{E}_{train} , meta-test campaigns \mathcal{E}_{test} , learning rate β , γ and δ , model M
Parameters: campaign-general adapter Ψ , campaign-specific adapter Ψ_e , BERT Φ , linear classifier Ω , learning rate α

```

1: ### Meta-training ###
2: Fine-tune base  $M$  on  $\mathcal{E}_{train}$  and provide initial model parameters  $\Phi$  #Stage 1
3: while not done do #Stage 2
4:   for  $e \in \mathcal{E}_{train}$  do
5:     Sample batch of tasks  $\mathcal{T}_i \in \mathcal{T}$ 
6:     for each  $\mathcal{T}_i$  do
7:       Sample  $S$  data-points to form  $\mathcal{D}^s = \{(\mathbf{u}_i, y_i)\}_{i=1}^S \in \mathcal{T}_i$  as support set
8:       Sample  $Q$  data-points to form  $\mathcal{D}^q = \{(\mathbf{u}_i, y_i)\}_{i=1}^Q \in \mathcal{T}_i$  as query set for meta-update
9:       Compute  $\nabla_{\Psi} \mathcal{L}(M_{\Phi, \Psi})$  on  $\mathcal{D}^s$ 
10:      Compute adapted parameters for adapter:  $\Psi' = \Psi - \alpha \nabla_{\Psi} \mathcal{L}_{\mathcal{T}_i}(M_{\Phi, \Psi})$ 
11:      Compute  $\mathcal{L}_{\mathcal{T}_i}(M_{\Phi, \Psi'})$  on  $\mathcal{D}^q$ 
12:    end for
13:    Update adapter parameters:  $\Psi \leftarrow \Psi - \beta \nabla_{\Psi} \mathbb{E}_{\mathcal{T}_i \sim \mathcal{T}} [\mathcal{L}_{\mathcal{T}_i}(M_{\Phi, \Psi'}, \mathcal{D}^q)]$ 
14:    Update inner loop learning rate:  $\alpha \leftarrow \Psi - \beta \nabla_{\alpha} \mathbb{E}_{\mathcal{T}_i \sim \mathcal{T}} [\mathcal{L}_{\mathcal{T}_i}(M_{\Phi, \Psi'}, \mathcal{D}^q)]$ 
15:  end for
16: end while
17: while not done do #Stage 3
18:   for  $e \in \mathcal{E}_{train}$  do
19:     Sample batch of tasks  $\mathcal{T}_i \in \mathcal{T}$ 
20:     for each  $\mathcal{T}_i$  do
21:       Sample  $S$  data-points to form  $\mathcal{D}^s = \{(\mathbf{u}_i, y_i)\}_{i=1}^S \in \mathcal{T}_i$  as support set
22:       Sample  $Q$  data-points to form  $\mathcal{D}^q = \{(\mathbf{u}_i, y_i)\}_{i=1}^Q \in \mathcal{T}_i$  as query set for meta-update
23:       Compute mean troll and non-troll representations based on support set
24:       Compute  $\nabla_{\Psi_e, \Omega_e} \mathcal{L}(M_{\Phi, \Psi_e, \Omega_e})$  on  $\mathcal{D}^s$ 
25:       Compute adapted parameters for adapter:  $\Psi'_e = \Psi_e - \gamma \nabla_{\Psi_e} \mathcal{L}_{\mathcal{T}_i}(M_{\Phi, \Psi_e, \Omega_e})$ 
26:       Compute adapted parameters for classifier:  $\Omega'_e = \Omega_e - \gamma \nabla_{\Omega_e} \mathcal{L}_{\mathcal{T}_i}(M_{\Phi, \Psi_e, \Omega_e})$ 
27:       Compute  $\mathcal{L}_{\mathcal{T}_i}(M_{\Phi, \Psi'_e, \Omega'_e})$  on  $\mathcal{D}^q$ 
28:     end for
29:     Update campaign-specific adapter parameters:  $\Psi_e \leftarrow \Psi_e - \delta \nabla_{\Psi_e} \mathbb{E}_{\mathcal{T}_i \sim \mathcal{T}} [\mathcal{L}_{\mathcal{T}_i}(M_{\Phi, \Psi'_e, \Omega'_e}, \mathcal{D}^q)]$ 
30:     Update classifier parameters:  $\Omega_e \leftarrow \Omega_e - \delta \nabla_{\Omega_e} \mathbb{E}_{\mathcal{T}_i \sim \mathcal{T}} [\mathcal{L}_{\mathcal{T}_i}(M_{\Phi, \Psi'_e, \Omega'_e}, \mathcal{D}^q)]$ 
31:   end for
32: end while
33: ### Meta-testing ###
34: Perform few-shot learning on meta-test campaigns  $\mathcal{E}_{test}$  using meta-learned parameters ( $\Phi, \Psi_e, \Omega_e$ )

```

we next compute the inner loop to update Ψ as follows [23]:

$$\mathcal{L}_{\mathcal{T}_i}(M_{\Phi, \Psi}, \mathcal{D}^s) = \frac{1}{|\mathcal{D}^s|} \sum_{\mathbf{u}_i \in \mathcal{D}^s} -\log p(y_i | \mathbf{u}_i; \Phi, \Psi)$$

$$\Psi' = \Psi - \alpha \nabla_{\Psi} \mathcal{L}(M_{\Phi, \Psi}, \mathcal{D}^s)$$

where α is the learning rate (computed next in the outer loop) and $\mathcal{L}_{\mathcal{T}_i}(M_{\Phi, \Psi}, \mathcal{D}^s)$ is the cross entropy loss over the support set. Next we compute the cross-entropy loss based on the query set, using the updated parameters:

$$\mathcal{L}_{\mathcal{T}_i}(M_{\Phi, \Psi'}, \mathcal{D}^q) = \frac{1}{|\mathcal{D}^q|} \sum_{\mathbf{u}_i \in \mathcal{D}^q} -\log p(y_i | \mathbf{u}_i; \Phi, \Psi')$$

This inner loop is carried out for multiple steps of gradient descent (using several tasks from the same campaign). Note that in this stage Φ (BERT parameters) is frozen. Once that's done, we

update the adapter parameters Ψ and inner loop learning rate α :³

$$\Psi \leftarrow \Psi - \beta \nabla_{\Psi} \mathbb{E}_{\mathcal{T}_i \sim \mathcal{T}} [\mathcal{L}_{\mathcal{T}_i}(M_{\Phi, \Psi'}, \mathcal{D}^q)]$$

$$\alpha \leftarrow \Psi - \beta \nabla_{\alpha} \mathbb{E}_{\mathcal{T}_i \sim \mathcal{T}} [\mathcal{L}_{\mathcal{T}_i}(M_{\Phi, \Psi'}, \mathcal{D}^q)]$$

where β is the learning rate for the outer loop (set to $1e^{-5}$ in our experiments).

4.3 Stage Three Training

In this stage, we introduce campaign-specific adapters for each campaign, and they are all initialised using the campaign-general adapter learned from the previous stage. Formally, Equation 3 is now updated to:

$$v = \text{AdapterBERT}_e([\text{CLS}] \oplus c_0 \oplus \dots \oplus c_n)$$

³In our implementation, α is layer-specific, i.e. we have a separate learning rate for each adapter in different layers.

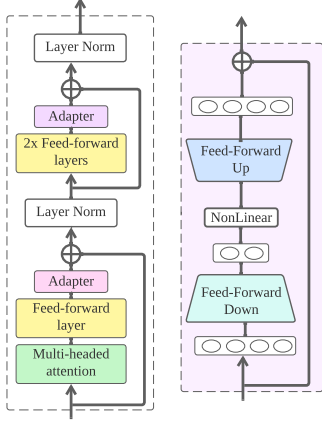

Figure 2: Overall architecture of Adapter-BERT. The left figure illustrates how two adapter modules are added to a transformer layer; right shows the components in the adapter.

where e is the campaign.

We introduce campaign-specific adapters to our model for two reasons: (1) they are more efficient to train and less vulnerable to overfitting (which is important in a few-shot learning setting), since they contain only a small number of parameters compared to the alternative where we have one BERT model for every campaign); and (2) they alleviate catastrophic forgetting in a continual learning setting, as each campaign has its own adapter.

Inspired by Requeima et al. [28], we next introduce an adaptive linear classifier network that replaces W and b in the linear layer used for classification (Equation 2). Intuitively, this adaptive classifier works by first computing the aggregate troll and non-troll representation for each campaign, and then learn campaign-specific projections to classify between trolls vs. non-trolls. Let \mathcal{D}_0^s and \mathcal{D}_1^s denote the support set where the labels are trolls ($y = 0$) and non-trolls ($y = 1$) respectively, we compute W_e , b_e and \hat{y} for troll campaign e as follows:

$$W_e^0 = \frac{1}{|\mathcal{D}_0^s|} \sum_{v \in \mathcal{D}_0^s} (v) \quad b_e^0 = \frac{1}{|\mathcal{D}_0^s|} \sum_{v \in \mathcal{D}_0^s} (v)$$

$$W_e^1 = \frac{1}{|\mathcal{D}_1^s|} \sum_{v \in \mathcal{D}_1^s} (v) \quad b_e^1 = \frac{1}{|\mathcal{D}_1^s|} \sum_{v \in \mathcal{D}_1^s} (v)$$

$$\hat{y} = \text{softmax}(W_e v + b_e)$$

where W_e^i denotes the $(i - 1)^{\text{th}}$ column of W_e . In other words, MetaTroll classifies a user based on whether its representation (v) is closer to the (average) troll or non-troll representation.

The campaign-specific adaptive linear classifier parameters Ω_e and the adapters parameters Ψ_e are trained using MAML, just like stage 2 training (line 17–31 in Algorithm 1).

4.4 Meta-testing

After MetaTroll is trained, to adapt it to a new campaign e , we follow the process of the third stage training. To simulate few-shot learning, we sample only a small number of instances for the support and query set (e.g. 5 each), and use *only* the support set

for updating the adapter (Ψ_e) and classifier parameters (Ω_e) (line 25–26 in Algorithm 1) and do not run the outer loop ((line 30–31). Here the query set is used only for computing performance (i.e. in line 27 we compute accuracy instead of loss over the query set).

5 EXPERIMENTS AND RESULTS

5.1 Datasets and models

We use the information operations dataset published by Twitter for our experiments.⁴ This dataset contains different groups of users banned by Twitter since October 2018 for engaging in state-sponsored information operations, and each group represents a *campaign* in our work. For example, the “Iran-2018-Palestine” campaign refers to trolls sponsored by Iran for an information campaign targeting Palestine in 2018.⁵ To clarify, these campaigns are defined by Twitter when they release the data, and each campaign is associated with a blogpost that explains the information operation.

For each campaign, we filter users and keep only those who have posted a tweet within the 6-month event period (“Event Time” in Table 1) to remove users who are inactive during the event.⁶ For each user, we also filter their tweets to keep only their most recent 20 posts that have a timestamp within the event period.

To create the non-troll users, we combine two sources: (1) “Random”, random accounts that are sampled by generating random numeric user IDs and validating their existence following [2]; and (2) “Hashtag”, users whose posts contain popular hashtags used by a campaign, where popular hashtags are defined as hashtags that collectively cover 75% of trolls’ posts. The reason why we have two types of non-troll users is that if we only sample random users as non-trolls, the post content of non-trolls would be *topically* very different to that of the trolls, and the detection task would degenerate into a topic detection task. The non-troll users sampled using the “Hashtag” approach is designed to circumvent this and makes the detection task more challenging.

Table 1 present some statistics for trolls and non-trolls in different campaigns, where 6 are used for meta-training and 4 for meta-testing. Note that the non-trolls of a particular campaign are users sampled with the “Hashtag” approach, and the last row corresponds to non-troll users sampled using the “Random” approach. For these campaigns, at least 80% of the trolls’ posts are in English, and so they are used for the monolingual (English) experiments in the paper.⁷

The trolls and non-trolls in Table 1 represent the pool of users which we draw from to construct the final training/testing data. In all of our experiments, we keep the ratio of trolls to non-trolls to 50/50 through sampling, and when sampling for non-troll users, the ratio from the two sources (“Random” and “Hashtag”) is also 50/50.⁸ As an example, “Uganda-2021-NRM” has 334 troll users. We therefore sample 334 non-troll users, where 167 are from “Random” and another 167 from “Hashtag”.

⁴<https://transparency.twitter.com/en/reports/information-operations.html>

⁵https://blog.twitter.com/en_us/topics/company/2018/enabling-further-research-of-information-operations-on-twitter

⁶The event period is determined as follows: (1) the end date is the last post in the campaign; and the (2) start date is 6 months from the end date.

⁷For non-troll users, we only keep English tweets (based on the predicted language given in the metadata).

⁸We also only sample “Random” users whose most recent post is in the event time.

Table 1: Statistics of English meta-train and meta-test data. The last row is non-troll users that are sampled by generating random user Twitter IDs.

Train/Test	Campaign	Event Time	Type	#users	Top-3 Hashtags
Meta-Train	Iran-2018-Palestine	Feb 2018 – Aug 2018	Troll	557	#realiran #SavePalestine
			Non-troll	1,063	#InternationalQudsDay2018
	Russia-2016-MAGA	Aug 2015 – Feb 2016	Troll	247	#MAGA #QAnon
			Non-troll	663	#ReleaseTheMemo
	Iran-2018-Pakistan	May 2018 – Nov 2018	Troll	2,267	#pakonlinenews
			Non-troll	2,500	#SachTimes #DeleteIsrael
	Venezuela-2018-Trump	Jun 2018 – Dec 2018	Troll	1,330	#TrumpTrain #MAGA #RT
			Non-troll	1,500	
	Nigeria-2019-Racism	Aug 2019 – Feb 2020	Troll	1,120	#racism
			Non-troll	1,200	#BlackLivesMatter #PoliceBrutality
	Iran-2020-BLM	Jul 2020 – Jan 2021	Troll	205	#black_lives_matter
			Non-troll	212	#Oscars #EEUU
Meta-Test	GRU-2020-NATO	Jun 2020 – Dec 2020	Troll	35	#Syria #Idib
			Non-troll	135	#StopTerrorismInSyria
	IRA-2020-Russia	Jun 2020 – Dec 2020	Troll	20	#valdaiclub #Russia #Ukraine
			Non-troll	81	
	Uganda-2021-NRM	Jul 2020 – Jan 2021	Troll	334	#SecuringYourFuture
			Non-troll	542	#M7UGsChoice #StopHooligansim
	China-2021-Xinjiang	Jul 2020 – Jan 2021	Troll	3,440	#Xinjiang
			Non-troll	2,345	#XinjiangOnline #Urumqi
	Random	Varies	Non-troll	8,000	#entertainment #SoundCloud #Vegas

We compare our MetaTroll model against the following baselines including state-of-the-art meta-learning methods and few-shot text classification models:

- **BERT** [11]⁹: BERT fine-tuned using the support set of meta-test data.
- **KNN** [21]: K -nearest neighbour classifier with off-the-shelf BERT as the feature extractor.¹⁰
- **AdBERT** [27]¹¹: BERT that fine-tunes an adapter for each campaign.
- **GPT3** [7]¹²: a very large pretrained model adapted to our tasks using prompt-based learning [24].¹³
- **MAML** [14]¹⁴: BERT trained with the MAML algorithm for few-shot learning.
- **CNP** [16]¹⁵: a model-based meta-learning framework that consists of a shared encoder, aggregator and decoder.
- **ProtoNet** [33]¹⁶: a deep metric-based approach using sample average as class prototypes and the distance is calculated based on euclidean-distance.
- **Induct** [17]: a few-shot classification model that uses a dynamic routing algorithm to learn a class-wise representation.

- **HATT** [15]¹⁷: A classification model of metric-based meta-learning framework together with attention mechanism.
- **DS** [5]¹⁸: A few-shot text classification model that uses distributional signatures such as word frequency and information entropy for training.

5.2 Results

We first present English troll detection performance. In Sections 5.4 and 5.5 we extend MetaTroll to work with non-English data and images. As we focus on English here, non-English posts are discarded (although this only reduces the data size by a negligible amount, as most data is in English, as explained in Section 5.1). All reported figures are an average accuracy performance over 5 runs with different random seeds.¹⁹

Table 2 presents 5-shot and 10-shot results for the 4 meta-test campaigns.²⁰ MetaTroll is the best model, achieving an average of 76.35% accuracy over all campaigns. That said, some of the few-shot text classifiers (Induct e.g.73.57%) are not far behind. Most models only benefit marginally by seeing 5 more examples going from 5- to 10-shot, with the exception of GPT3 where we see a substantial performance boost (average 14.64% gain).

5.3 Continual learning performance

In continual learning [29], new tasks appear over time, where the goal of learning is to adapt the model accordingly to the new tasks

⁹https://huggingface.co/docs/transformers/model_doc/bert

¹⁰ K is selected from [5,10].

¹¹<https://adapterhub.ml/>

¹²<https://gpt3demo.com/apps/openai-gpt-3-playground>

¹³We use “text-davinci-002” in our experiments. The prompts are a small set of instances (e.g. 5) with their labels added to the beginning of the input.

¹⁴<https://github.com/tristandeleu/pytorch-meta/tree/master/examples/maml>

¹⁵<https://github.com/deepmind/neural-processes>

¹⁶<https://github.com/orobix/Prototypical-Networks-for-Few-shot-Learning-PyTorch>

¹⁷<https://github.com/thunlp/HATT-Proto>

¹⁸<https://github.com/YujiaBao/Distributional-Signatures>

¹⁹Noting that the performance for one run is an average performance over the query sets from multiple tasks.

²⁰5-shot means only 5 labelled instances for each class are given in the support set.

Table 2: Troll detection accuracy in 5-shot and 10-shot settings.

Model	GRU-2020-NATO		IRA-2020-Russia		Uganda-2021-NRM		China-2021-Xinjiang	
	5-shot	10-shot	5-shot	10-shot	5-shot	10-shot	5-shot	10-shot
BERT [11]	50.41	51.39 $\uparrow_{0.98}$	51.70	52.21 $\uparrow_{0.51}$	55.96	56.53 $\uparrow_{0.39}$	60.36	61.68 $\uparrow_{1.32}$
KNN [21]	46.10	48.91 $\uparrow_{2.81}$	42.52	44.28 $\uparrow_{1.76}$	46.74	48.49 $\uparrow_{1.75}$	50.21	51.85 $\uparrow_{1.37}$
AdBERT [27]	65.05	66.73 $\uparrow_{1.68}$	55.16	57.39 $\uparrow_{2.23}$	52.24	56.27 $\uparrow_{4.03}$	65.49	67.38 $\uparrow_{1.89}$
GPT3 [7]	54.25	71.39 $\uparrow_{17.14}$	61.87	75.96 $\uparrow_{14.09}$	52.49	69.66 $\uparrow_{17.17}$	70.34	80.49 $\uparrow_{10.15}$
MAML [14]	70.13	72.43 $\uparrow_{2.30}$	70.11	71.82 $\uparrow_{1.71}$	61.11	65.74 $\uparrow_{4.63}$	70.99	73.87 $\uparrow_{2.85}$
CNP [16]	69.88	71.26 $\uparrow_{1.38}$	69.47	72.70 $\uparrow_{3.23}$	64.48	66.95 $\uparrow_{2.47}$	67.05	69.95 $\uparrow_{2.90}$
ProtoNet [33]	60.43	62.87 $\uparrow_{2.44}$	67.87	70.05 $\uparrow_{2.18}$	64.43	67.79 $\uparrow_{3.36}$	74.56	76.65 $\uparrow_{2.09}$
Induct [17]	71.11	72.26 $\uparrow_{1.15}$	76.49	77.24 $\uparrow_{0.75}$	71.55	73.50 $\uparrow_{1.95}$	75.13	76.70 $\uparrow_{1.57}$
HATT [15]	63.02	65.56 $\uparrow_{2.54}$	75.82	77.50 $\uparrow_{1.68}$	60.45	63.87 $\uparrow_{3.42}$	78.22	80.03 $\uparrow_{1.81}$
DS [5]	62.69	64.62 $\uparrow_{1.93}$	66.05	68.92 $\uparrow_{2.87}$	62.43	64.50 $\uparrow_{2.07}$	71.74	73.43 $\uparrow_{1.69}$
MetaTroll	72.74	75.13 $\uparrow_{2.39}$	76.25	77.99 $\uparrow_{1.74}$	75.05	78.25 $\uparrow_{3.20}$	81.37	84.50 $\uparrow_{3.13}$

Table 3: Catastrophic forgetting results under continual learning. “G” = GRU-2020-NATO, “I” = IRA-2020-Russia, “U” = Uganda-2021-NRM, “C” = China-2021-Xinjiang.

Model	G→I		G→I→U		G→I→U→C		
	G	G	G	I	G	I	U
BERT [11]	50.41	45.16	48.02	44.80	42.85	43.25	50.00
KNN [21]	46.10	45.25	43.12	49.99	43.01	45.50	45.33
AdBERT [27]	65.05	62.41	54.59	52.56	50.54	53.74	49.95
GPT3 [7]	54.25	51.92	50.33	58.88	48.93	56.87	50.06
MAML [14]	70.13	68.32	65.15	56.55	57.62	50.04	54.87
CNP [16]	69.88	71.55	68.72	56.75	60.57	56.95	63.21
ProtoNet [33]	60.43	56.56	61.05	61.99	53.47	52.83	60.05
Induct [17]	71.11	69.50	62.82	66.13	58.43	63.52	64.83
HATT [15]	63.02	60.50	55.62	70.18	50.25	50.11	55.43
DS [5]	62.69	60.05	58.85	61.50	50.65	60.12	61.85
MetaTroll	72.74	73.45	72.18	70.81	71.15	69.74	68.75

Table 4: Campaign classification results under continual learning.

Model	G→I		G→I→U		G→I→U→C		
	I	I	I	U	I	U	C
GPT3 [7]	74.86	79.25	82.86	81.17	79.38	74.62	
MetaTroll	85.57	85.15	87.50	83.61	86.92	86.11	

without forgetting the previous tasks. This is a more realistic setting for a troll detection system, as it should continually adapt to new campaigns that appear over time. But in this setting it will suffer from catastrophic forgetting [36, 37], where after adapting to newer campaigns its performance to classify older campaigns will degrade.

To simulate this continual learning setting, we next evaluate the troll detection models on a *past campaign* after it has been adapted for a number of campaigns in sequence. For example, a system is first adapted to GRU-2020-NATO (G), and then to IRA-2020-Russia (I), Uganda-2021-NRM (U) and China-2021-Xinjiang (C) in sequence (denoted as G→I→U→C). We then test the system using trolls using the past campaigns, i.e. G, I and U.

One challenge with MetaTroll under this continual learning evaluation is that at test time it needs to know which adapter to use – information that most other systems do not require as they don’t have campaign-specific parameters (exception: AdBERT and GPT-3²¹). We experiment a simple approach to solve this: have MetaTroll classify a user using all its adapters, and select the outcome that has the highest probability.²²

We present (5-shot) troll classification results under this continual learning setting in Table 3. AdBERT and GPT-3 suffers little catastrophic forgetting, as they have campaign-specific parameters or prompts (they are unaffected by continual learning as their base model is unchanged), although their performance is only marginally above random chance in the first place. MetaTroll is the clear winner here, with only <5% accuracy degradation over time.²³ In contrast, the meta-learning methods and few-shot classifiers suffer from catastrophic forgetting and their performance on older campaigns drops substantially (e.g. MAML’s performance for GRU-2020-NATO drops from 68.32 to 65.15 and 57.62 after several updates).

An unintended benefit of that MetaTroll classifies trolls using multiple adapters is that it is effectively doing multi-class rather than binary classification (with over 85% accuracy for campaign classification; Table 4). What this means is that not only MetaTroll is able to retain its performance for classifying trolls vs. non-trolls from different campaigns over time, it can also predict which campaign an instance belongs to – an arguably more difficult task.

5.4 Multilingual performance

We extend MetaTroll to multilingual. To encode multilingual input text, we replace BERT with XLM-R [9].²⁴ For comparison, we include baselines BERT, KNN, and AdBERT, and meta-learning methods ProtoNet and MAML as their base model can be replaced with XLM-R. We exclude the few-shot classifiers as they are designed for English and cannot be trivially adapted to other languages.

²¹GPT3 technically does not have campaign-specific parameters, but it needs to be given campaign-specific prompts, and so requires the campaign label.

²²We do the same for AdBERT and GPT3.

²³Note that performance of these systems on older campaigns will still degrade slightly over more adaptations, as there are more campaign-specific adapters or prompts to select from.

²⁴Specifically, we use the following library that implements adapters into XLM-R: <https://docs.adapterhub.ml/classes/models/xlmroberta.html>

Table 5: Statistics of Multilingual meta-test data. Languages are in ISO code.

Campaign	Event Time	Language	Type	#users	Top-3 Hashtags
Thailand-2020-RTA	Aug 2019 – Feb 2020	th, en	Troll	158	#army #parade
			Non-troll	542	#TheRoyalThaiArmy
Mexico-2021-Election	Sep 2020 – Mar 2021	es, en	Troll	190	#Elections2021
			Non-troll	542	#Elections2021MX #PollsMX
Venezuela-2021-Gov	Nov 2020 – May 2021	es, en	Troll	257	#Venezuela
			Non-troll	756	#ConTodoPorLaPatria #Live
China-2021-Changyu	Feb 2019 – Aug 2019	fr,en	Troll	280	#MBR #MorningBox
			Non-troll	542	#StopXinjiangRumors
Random	Varies	es, fr, th, en	Non-troll	5,000	#news #COVID #Daily

Table 6: Multilingual results. “G” = GRU-2020-NATO, “I” = IRA-2020-Russia, “U” = Uganda-2021-NRM, “C” = China-2021-Xinjiang, “T” = Thailand-2020-RTA, “M” = Mexico-2021-Election, “V” = Venezuela-2021-Gov, “Y” = China-2021-Changyu

Model	G	I	U	C	T	M	V	Y
BERT [9]	51.83	48.69	53.21	55.56	53.54	54.98	54.27	52.82
KNN [21]	47.38	42.50	44.21	48.29	56.36	51.12	55.63	50.19
AdBERT [27]	58.38	56.29	54.79	66.65	62.71	56.20	58.41	55.63
ProtoNet [33]	57.78	64.47	60.40	70.52	63.68	59.56	62.71	58.96
MAML [14]	67.15	65.58	55.32	69.68	65.32	57.68	60.00	51.36
MetaTroll	69.63	70.52	73.72	73.20	68.14	64.82	67.16	62.53

Table 7: Multilingual and multimodal results. “+R” = ResNet18, “+O” = OCR, “+R+O” = “+ResNet18+OCR”.

Variants	G	I	U	C	T	M	V	Y
-image	69.63	70.52	73.72	73.20	68.14	64.82	67.16	62.53
+image#	70.81	71.03	74.02	73.97	68.89	65.11	67.94	63.07
+R	71.15	72.81	75.50	74.38	72.25	67.50	68.55	65.74
+O	72.10	74.55	75.95	75.59	71.50	69.54	72.07	71.45
+R+O	73.22	73.08	76.17	73.04	76.62	70.83	71.95	72.77

In terms of data, we expand the meta-test campaigns by adding four new campaigns (Thailand-2020-RTA, Mexico-2021-Election, Venezuela-2021-Gov, and China-2021-Changyu) where the predominant language is not in English and present their statistics in Table 5. For the 10 English campaigns (Table 1), we restore the previously discarded non-English posts and include them for meta-training and meta-testing.

Results are presented in Table 6. Generally we see that all models’ performance has somewhat degraded when their feature extractor is replaced with a multilingual model, although MetaTroll manages to keep its accuracy around 60%. Interestingly, China-2021-Changyu appears to be the most difficult campaign, and we suspect it may be due to its diverse set of languages (38% French, 12.3% English, 12.1% Simplified Chinese).

5.5 Multimodal performance

Next we consider incorporating images posted by users, as image is an effective communication device (e.g. memes). Note that we only present results for different variants of MetaTroll here, as we have demonstrated that it is the most competitive detection system.

To process images, we use pre-trained ResNet18 [18] as an off-the-shelf tool to extract image embeddings. We also explore using a multilingual OCR model to extract text information from images (which will be useful for processing memes).²⁵ As we have multiple images for each user, we aggregate the ResNet18 image embeddings via max-pooling, and concatenate the max-pooled vector with the text representation (v in Equation 3). For texts that are extracted by OCR, we concatenate them into a long string and process them with another AdapterBERT (Equation 3; their parameters are not shared), and similarly concatenate the final CLS representation to the text representation.

Results are in Table 7. “+image#” is a baseline where we concatenate a numeric feature that denotes the number of images posted by the user to the text representation. Interestingly, even with the baseline approach we see a small improvement, indicating that trolls use more images (e.g. average number of images used by trolls is 20 vs. 5 for non-trolls in GRU-2020-NATO). Incorporating either ResNet or OCR encodings boosts performance further (with OCR being marginally more beneficial), and that adding them both produces the best performance.

6 CONCLUSION

We propose MetaTroll, a few-shot troll detection model with campaign-specific adapters that tackles catastrophic forgetting in a continual learning setting. Experimental results show that MetaTroll outperforms existing state-of-the-art meta-learning and few-shot text classification models, and it can be extended to handle multilingual and multimodal input.

ACKNOWLEDGEMENTS

This research is supported in part by the Australian Research Council Discovery Project DP200101441. Lin Tian is supported by the RMIT University Vice-Chancellor PhD Scholarship (VCPS).

²⁵<https://github.com/JaidedAI/EasyOCR>

REFERENCES

- [1] Aseel Addawood, Adam Badawy, Kristina Lerman, and Emilio Ferrara. 2019. Linguistic cues to deception: Identifying political trolls on social media. In *Proceedings of the international AAAI conference on web and social media*, Vol. 13. 15–25.
- [2] Meysam Alizadeh, Jacob N Shapiro, Cody Buntain, and Joshua A Tucker. 2020. Content-based features predict social media influence operations. *Science advances* 6, 30 (2020), eabb5824.
- [3] Atanas Atanasov, Gianmarco De Francisci Morales, and Preslav Nakov. 2019. Predicting the Role of Political Trolls in Social Media. In *Proceedings of the 23rd Conference on Computational Natural Language Learning (CoNLL)*. 1023–1034.
- [4] Adam Badawy, Kristina Lerman, and Emilio Ferrara. 2019. Who falls for online political manipulation?. In *Companion Proceedings of The 2019 World Wide Web Conference*. 162–168.
- [5] Yujia Bao, Menghua Wu, Shiyu Chang, and Regina Barzilay. 2020. Few-shot Text Classification with Distributional Signatures. In *ICLR*.
- [6] David A Broniatowski, Amelia M Jamison, SiHua Qi, Lulwah AlKulaib, Tao Chen, Adrian Benton, Sandra C Quinn, and Mark Dredze. 2018. Weaponized health communication: Twitter bots and Russian trolls amplify the vaccine debate. *American journal of public health* 108, 10 (2018), 1378–1384.
- [7] Tom Brown, Benjamin Mann, Nick Ryder, Melanie Subbiah, Jared D Kaplan, Prafulla Dhariwal, Arvind Neelakantan, Pranav Shyam, Girish Sastry, Amanda Askell, et al. 2020. Language models are few-shot learners. *Advances in neural information processing systems* 33 (2020), 1877–1901.
- [8] Justin Cheng, Cristian Danescu-Niculescu-Mizil, and Jure Leskovec. 2015. Antisocial behavior in online discussion communities. In *Proceedings of the international aaii conference on web and social media*, Vol. 9. 61–70.
- [9] Alexis Conneau, Kartikay Khandelwal, Naman Goyal, Vishrav Chaudhary, Guillaume Wenzek, Francisco Guzmán, Édouard Grave, Mylé Ott, Luke Zettlemoyer, and Veselin Stoyanov. 2020. Unsupervised Cross-lingual Representation Learning at Scale. In *Proceedings of the 58th Annual Meeting of the Association for Computational Linguistics*. 8440–8451.
- [10] Jorge De-La-Peña-Sordo, Igor Santos, Iker Pastor-López, and Pablo G Bringas. 2013. Filtering trolling comments through collective classification. In *International Conference on Network and System Security*. Springer, 707–713.
- [11] Jacob Devlin, Ming-Wei Chang, Kenton Lee, and Kristina Toutanova. 2018. Bert: Pre-training of deep bidirectional transformers for language understanding. *arXiv preprint arXiv:1810.04805* (2018).
- [12] Imen Ouled Dlala, Dorra Attiaoui, Arnaud Martin, and Boutheina Ben Yaghlane. 2014. Trolls identification within an uncertain framework. In *2014 IEEE 26th International Conference on Tools with Artificial Intelligence*. IEEE, 1011–1015.
- [13] Ritam Dutt, Ashok Deb, and Emilio Ferrara. 2018. “Senator, We Sell Ads”: Analysis of the 2016 Russian Facebook Ads Campaign. In *International conference on intelligent information technologies*. Springer, 151–168.
- [14] Chelsea Finn, Pieter Abbeel, and Sergey Levine. 2017. Model-agnostic meta-learning for fast adaptation of deep networks. In *International conference on machine learning*. PMLR, 1126–1135.
- [15] Tianyu Gao, Xu Han, Zhiyuan Liu, and Maosong Sun. 2019. Hybrid attention-based prototypical networks for noisy few-shot relation classification. In *Proceedings of the AAAI Conference on Artificial Intelligence*, Vol. 33. 6407–6414.
- [16] Marta Garnelo, Dan Rosenbaum, Christopher Maddison, Tiago Ramalho, David Saxton, Murray Shanahan, Yee Whye Teh, Danilo Rezende, and SM Ali Eslami. 2018. Conditional neural processes. In *International Conference on Machine Learning*. PMLR, 1704–1713.
- [17] Ruiying Geng, Binhua Li, Yongbin Li, Xiaodan Zhu, Ping Jian, and Jian Sun. 2019. Induction Networks for Few-Shot Text Classification. In *Proceedings of the 2019 Conference on Empirical Methods in Natural Language Processing and the 9th International Joint Conference on Natural Language Processing (EMNLP-IJCNLP)*. 3904–3913.
- [18] Kaiming He, Xiangyu Zhang, Shaoqing Ren, and Jian Sun. 2016. Deep residual learning for image recognition. In *Proceedings of the IEEE conference on computer vision and pattern recognition*. 770–778.
- [19] Neil Houlsby, Andrei Giurgiu, Stanislaw Jastrzebski, Bruna Morrone, Quentin De Laroussilhe, Andrea Gesmundo, Mona Attariyan, and Sylvain Gelly. 2019. Parameter-efficient transfer learning for NLP. In *International Conference on Machine Learning*. PMLR, 2790–2799.
- [20] Jane Im, Eshwar Chandrasekharan, Jackson Sargent, Paige Lighthammer, Taylor Denby, Ankit Bhargava, Libby Hemphill, David Jurgens, and Eric Gilbert. 2020. Still out there: Modeling and identifying russian troll accounts on twitter. In *12th ACM Conference on Web Science*. 1–10.
- [21] Urvashi Khandelwal, Omer Levy, Dan Jurafsky, Luke Zettlemoyer, and Mike Lewis. 2020. Generalization through Memorization: Nearest Neighbor Language Models. In *International Conference on Learning Representations*.
- [22] Diederik P Kingma and Jimmy Ba. 2014. Adam: A method for stochastic optimization. *arXiv preprint arXiv:1412.6980* (2014).
- [23] Zhenguo Li, Fengwei Zhou, Fei Chen, and Hang Li. 2017. Meta-sgd: Learning to learn quickly for few-shot learning. *arXiv preprint arXiv:1707.09835* (2017).
- [24] Pengfei Liu, Weizhe Yuan, Jinlan Fu, Zhengbao Jiang, Hiroaki Hayashi, and Graham Neubig. 2021. Pre-train, prompt, and predict: A systematic survey of prompting methods in natural language processing. *arXiv preprint arXiv:2107.13586* (2021).
- [25] Todor Mihaylov, Ivan Koychev, Georgi Georgiev, and Preslav Nakov. 2015. Exposing Paid Opinion Manipulation Trolls. In *Proceedings of the International Conference Recent Advances in Natural Language Processing*. 443–450.
- [26] Tsendsuren Munkhdalai and Hong Yu. 2017. Meta networks. In *International Conference on Machine Learning*. PMLR, 2554–2563.
- [27] Jonas Pfeiffer, Andreas Rücklé, Clifton Poth, Aishwarya Kamath, Ivan Vulić, Sebastian Ruder, Kyunghyun Cho, and Iryna Gurevych. 2020. AdapterHub: A Framework for Adapting Transformers. In *Proceedings of the 2020 Conference on Empirical Methods in Natural Language Processing: System Demonstrations*. 46–54.
- [28] James Requeima, Jonathan Gordon, John Bronskill, Sebastian Nowozin, and Richard E Turner. 2019. Fast and flexible multi-task classification using conditional neural adaptive processes. *Advances in Neural Information Processing Systems* 32 (2019).
- [29] Mark B Ring. 1998. CHILd: A first step towards continual learning. In *Learning to learn*. Springer, 261–292.
- [30] Adam Santoro, Sergey Bartunov, Matthew Botvinick, Daan Wierstra, and Timothy Lillicrap. 2016. Meta-learning with memory-augmented neural networks. In *International conference on machine learning*. PMLR, 1842–1850.
- [31] Chun Wei Seah, Hai Leong Chieu, Kian Ming A Chai, Loo-Nin Teow, and Lee Wei Yeong. 2015. Troll detection by domain-adapting sentiment analysis. In *2015 18th International Conference on Information Fusion (Fusion)*. IEEE, 792–799.
- [32] Hossein Shafiei and Aresh Dadlani. 2022. Detection of fickle trolls in large-scale online social networks. *Journal of big Data* 9, 1 (2022), 1–21.
- [33] Jake Snell, Kevin Swersky, and Richard Zemel. 2017. Prototypical networks for few-shot learning. *Advances in neural information processing systems* 30 (2017).
- [34] James Stewart and Maurice Dawson. 2018. How the modification of personality traits leave one vulnerable to manipulation in social engineering. *International Journal of Information Privacy, Security and Integrity* 3, 3 (2018), 187–208.
- [35] Oriol Vinyals, Charles Blundell, Timothy Lillicrap, Daan Wierstra, et al. 2016. Matching networks for one shot learning. *Advances in neural information processing systems* 29 (2016).
- [36] Y. Xu, X. Zhong, A. Jimeno-Yepes, and J.H. Lau. 2020. Forget Me Not: Reducing Catastrophic Forgetting for Domain Adaptation in Reading Comprehension. In *Proceedings of the 2020 International Joint Conference on Neural Networks (IJCNN2020)*. Glasgow, UK, 1–8.
- [37] Pauching Yap, Hippolyt Ritter, and David Barber. 2021. Addressing catastrophic forgetting in few-shot problems. In *International Conference on Machine Learning*. PMLR, 11909–11919.
- [38] Mo Yu, Xiaoxiao Guo, Jinfeng Yi, Shiyu Chang, Saloni Potdar, Yu Cheng, Gerald Tesaro, Haoyu Wang, and Bowen Zhou. 2018. Diverse Few-Shot Text Classification with Multiple Metrics. In *Proceedings of the 2018 Conference of the North American Chapter of the Association for Computational Linguistics: Human Language Technologies, Volume 1 (Long Papers)*. 1206–1215.
- [39] Savvas Zannettou, Tristan Caulfield, Emiliano De Cristofaro, Michael Sirivianos, Gianluca Stringhini, and Jeremy Blackburn. 2019. Disinformation warfare: Understanding state-sponsored trolls on Twitter and their influence on the web. In *Companion proceedings of the 2019 world wide web conference*. 218–226.
- [40] Yini Zhang, Josephine Lukito, Min-Hsin Su, Jiyoun Suk, Yiping Xia, Sang Jung Kim, Larissa Doroshenko, and Chris Wells. 2021. Assembling the networks and audiences of disinformation: How successful Russian IRA Twitter accounts built their followings, 2015–2017. *Journal of Communication* 71, 2 (2021), 305–331.

A IMPLEMENTATION DETAILS

We implement our models in PyTorch using the HuggingFace library²⁶ and their pretrained BERT²⁷ and XML-R²⁸. The adapter-based models are from AdapterHub²⁹.

To handle images, we use ResNet18³⁰ and EasyOCR³¹.

We set maximum token length = 320 and dropout rate = 0.2 for BERT embedding and dropout rate = 0.1 for meta-learning process. Learning rate is tuned in the range between $[1e^{-5}, 5e^{-5}]$ for BERT in the first stage. Learning rate warmup is set up 10% of steps. The learning rate β for MAML outer loop is $1e^{-5}$. In the first stage, BERT uses the Adam optimiser [22]. Search space for learning rate γ and δ is from $[1e^{-4}, 1e^{-5}, 2e^{-5}, 3e^{-5}, 4e^{-5}, 5e^{-5}]$. The outer loop learning rate for the third stage δ is set as $1e^{-5}$. The inner loop learning rate γ for BERT-based models is set as $2e^{-5}$ and for XLM-R-based models is set as $5e^{-5}$. We experimented with the number of training tasks in the range of 60,000 to 100,000, with 80,000 tasks generally yielding the best results. Our experiments are running using A100 GPU with 40GB Memory.

B ABLATION STUDY

We conduct ablation study to justify the importance of our three stages training processes. By removing the adaptive classifier, we attach a standard linear layer for the final classification. For “s1+s2”, we attach a standard linear layer for the final classification with removing the adaptive classifier. “s2+s3” is initialise the BERT text encoder without pre-training on any troll data. “s1+s3” drops the meta-trained task-specific adapter. We still allocate one adapter to each task with randomly initialised adaptor. We report the average accuracy on four English meta-testing campaigns of different model variants in Table 8. Results show that our model, the combination of all three training stages achieves the best average accuracy of 76.35%. Without pretraining the base text encoder, the framework performs the worst, resulting in 3.04% drops on average accuracy.

Table 8: Ablation results.

Variants	G	I	U	C
s1 + s2	71.35	75.02	72.47	80.03
S1 + s3	72.43	74.81	72.25	79.55
s2 + s3	71.25	75.19	73.50	78.33
MetaTroll	72.74	76.25	75.05	81.37

C DATASET DETAILS

We further include a detailed statistics of our Twitter troll data with detailed topic for each campaign and online post link attached.

²⁶<https://github.com/huggingface>

²⁷<https://huggingface.co/bert-base-cased>

²⁸<https://huggingface.co/xlm-roberta-base>

²⁹[urlhttps://github.com/adapter-hub/adapter-transformers](https://github.com/adapter-hub/adapter-transformers)

³⁰<https://pytorch.org/vision/main/models/generated/torchvision.models.resnet18.html>

³¹<https://github.com/JaidedAI/EasyOCR>

Table 9: Statistics of Twitter data for troll and non-troll accounts. Languages are in ISO code.

Campaign	Topic	Event Time	Language	#posts
Iran-2018-Palestine	information campaigns potentially originated in Iran, dating back to 2009 [link]	Feb 2018 – Aug 2018	en,fr	276,495
Russia-2016-MAGA	behavior mimics the activity of prior accounts tied to the IRA [link]	Aug 2015 – Feb 2016	en	920,761
Iran-2018-Pakistan	possible malicious activity with an attempted influence campaign identified as potentially located within Iran [link]	May 2018 – Nov 2018	en	4,671,959
Venezuela-2018-Trump	were initial indications that these accounts were associated with the Russian IRA, further analysis suggests that they were operated by a commercial entity originating in Venezuela [link]	Jun 2018 – Dec 2018	en	569,453
Nigeria-2019-Racism	operating out of Ghana and Nigeria and which we can reliably associate with Russia, attempted to sow discord by engaging in conversations about social issues, like race and civil rights [link]	Aug 2019 – Feb 2020	en	39,964
Thailand-2020-RTA	a network of accounts partaking in information operations that we can reliably link to the Royal Thai Army (RTA). These accounts were engaging in amplifying pro-RTA and pro-government content, as well as engaging in behavior targeting prominent political opposition figures [link]	Aug 2019 – Feb 2020	th,en	21,385
Iran-2020-BLM	artificially amplified conversations on politically sensitive topics, including Black Lives Matter (BLM), the murder of George Floyd, and other issues of racial and social justice in the United States [link]	Jul 2020 – Jan 2021	en	2,450
IRA-2020-Russia	accounts amplified narratives that had been previously associated with the IRA and other Russian influence efforts targeting the United States and European Union [link]	Jun 2020 – Dec 2020	en	68,914
GRU-2020-NATO	accounts amplified narratives that were aligned with the Russian government, while other subset of the network focused on undermining faith in the NATO alliance and its stability [link]	Jun 2020 – Dec 2020	en	26,684
Mexico-2021-Election	shared primarily civic content, in support of government initiatives related to public health and political parties.[link]	Sep 2020 – Mar 2021	es,en	19,277
Venezuela-2021-Gov	amplified accounts, hashtags, and topics in support of the government and its official narratives [link]	Nov 2020 – May 2021	es,en	860,060
Uganda-2021-NRM	engaged in coordinated inauthentic activity in support of Ugandan presidential incumbent Museveni and his party, National Resistance Movement (NRM) [link]	Jul 2020 – Jan 2021	en	524,081
China-2021-Xinjiang	amplified Chinese Communist Party narratives related to the treatment of the Uyghur population in Xinjiang [link]	Jul 2020 – Jan 2021	en, zh-cn	31,269
China-2021-Changyu	“Changyu Culture” a private company backed by the Xinjiang regional government [link]	Feb 2019 – Aug 2019	fr, en	35,924