

# A Study of Slang Representation Methods

Aravinda Kolla<sup>1</sup>, Filip Ilievski<sup>1</sup>, Hông-Ân Sandlin<sup>2</sup>, and Alain Mermoud<sup>2</sup>

<sup>1</sup>University of Southern California, Information Sciences Institute, USA

<sup>2</sup>Cyber-Defence Campus, armasuisse Science and Technology, Switzerland  
{kollaa, ilievski}@isi.edu, {hongan.sandlin, alain.mermoud}@ar.admin.ch

## Abstract

Considering the large amount of content created online by the minute, slang-aware automatic tools are critically needed to promote social good, and assist policymakers and moderators in restricting the spread of offensive language, abuse, and hate speech. Despite the success of large language models and the spontaneous emergence of slang dictionaries, it is unclear how far their combination goes in terms of slang understanding for downstream social good tasks. In this paper, we provide a framework to study different combinations of representation learning models and knowledge resources for a variety of downstream tasks that rely on slang understanding. Our experiments show the superiority of models that have been pre-trained on social media data, while the impact of dictionaries is positive only for static word embeddings. Our error analysis identifies core challenges for slang representation learning, including out-of-vocabulary words, polysemy, variance, and annotation disagreements, which can be traced to characteristics of slang as a quickly evolving and highly subjective language.

## Introduction

The UN Sustainable Development Goals (Biermann, Kanie, and Kim 2017) emphasize the importance of gender equality, peace, and justice. Initiatives that envision the role of AI for social good (Tomašev et al. 2020) provide guidelines for supporting these goals through practical measures. A key application of AI is building tools that assist social media policymakers and moderators to restrict the spread of offensive language, abuse, and hate speech, e.g., sexism and misogyny, which are still prevalent all over the globe (Khan 2021). A recent study (Delisle et al. 2019) reveals worrying patterns of online abuse, estimating 1.1 million toxic tweets sent to women over one year. Another study by Mamié, Horta Ribeiro, and West demonstrates how “the Manosphere”, a conglomerate of men-centered online communities, may serve as a gateway to far-right movements. Web content moderation policies, or the lack thereof, can have serious implications on individuals, groups, and society as a whole. On the one hand, content moderators may react late, inconsistently, or unfairly, thus angering users (Habib

and Nithyanand 2022), as well as contributing to reinforcing and exacerbating conspiratorial narratives (Chen et al. 2021). On the other hand, minimal content moderation may permit coordinated influence operations (DiResta and Grossman 2019) or enable the spontaneous formation of toxic and dangerous communities (Mamié, Horta Ribeiro, and West 2021; Khan 2021).

While (computational) linguistics has typically focused on formal documents, like books, and curated text corpora, like Wikipedia, language on the internet is informal, dynamic, ever-evolving, and bottom-up (McCulloch 2020). Thus, automatic content analysis tools designed to assist social media policymakers and moderators need to possess the ability to understand informal language, i.e., *slang*. Slang, defined as “a peculiar kind of vagabond language, always hanging on the outskirts of legitimate speech, but continually straying or forcing its way into the most respectable company” (Greenough and Kittredge 1901), has long been of interest to linguists and social historians (Adams 2012; Partridge 2015; Davidson et al. 2017a). With the velocity and the volume of informal content on the Web, the notion of slang has recently broadened (McCulloch 2020): slang has moved beyond its traditional categories, like school, intergenerational, and intragenerational slang (Adams 2012), to loosely-defined communities and subcultures, like QAnon followers or men-centered online communities (Mamié, Horta Ribeiro, and West 2021).

How can we build representation learning methods that are capable of understanding slang? Can we apply or adapt large language models (LMs) for this purpose? Do dictionaries of slang or large social media datasets provide an effective opening for building specialized slang methods? Recognizing that most of the current LMs have been trained on formal English datasets that fail to capture the nuances of the social media language, prior work has devised tasks that test their abilities (Zampieri et al. 2020; Rosenthal, Farra, and Nakov 2017), methods that fine-tune them on benchmark-specific data (Nguyen, Vu, and Nguyen 2020), and resources that define and describe a comprehensive collection of slang words (Nguyen, McGillivray, and Yasseri 2017). It is unclear to what extent recent models and knowledge sources can understand slang, and what are the key limitations that affect their reasoning on slang-centric downstream tasks.

In this paper, we study the ability of combinations of lan-

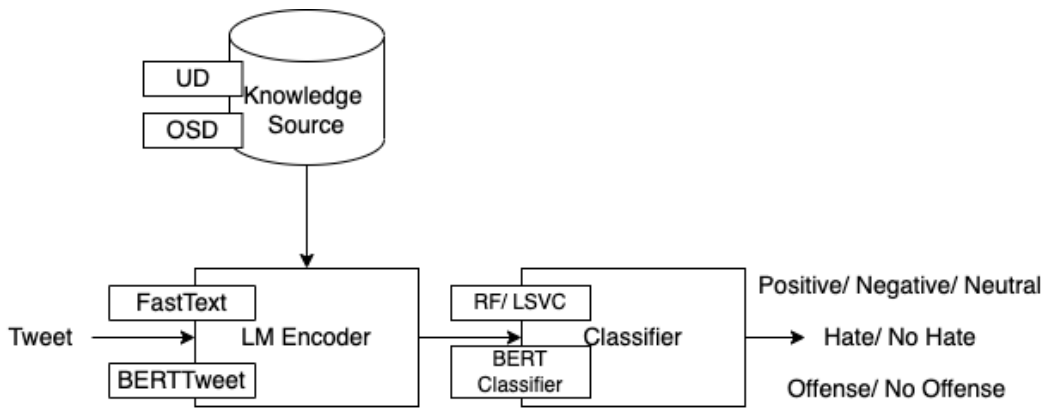

Figure 1: Overview of the Framework. RF is Random Forest Classifier and LSVC is Linear SVC classifier. UD is Urban Dictionary and OSD is online slang dictionary.

guage models and knowledge sources to comprehend slang in different tasks involving offense, hate, and abuse on social media. We analyze their behavior quantitatively and qualitatively, in order to surface the chief weaknesses of these models in terms of slang understanding and point to potential solutions going forward. We make the following contributions:

1. We design and implement a framework for slang representation learning methods. The framework integrates language model encoders, knowledge sources, and evaluation tasks.
2. We design experiments to answer key research questions empirically. We evaluate if existing FastText models trained on slang data answer key research questions. Our experiments with three models, two knowledge sources, and three tasks reveal differences between the ability of models to capture slang, as well as inherent challenges that require innovative approaches.
3. We reflect on our findings, connecting them to the characteristics of slang as a quickly evolving language, and as a subjective and circumstantial phenomenon causing ambiguity in downstream tasks.

We make our code and data available at <https://github.com/usc-isi-i2/slang-representation-learning>.

## Slang Representation Framework

Our study is based on a framework that combines different language models, knowledge sources, and evaluation tasks (Figure 1). We describe the framework’s components in turn.

### Models

**FastText** FastText embeddings represent each word as a bag of character n-grams, which helps in overcoming the limitation of models that ignore the morphology of words (Bojanowski et al. 2016). In (Wilson et al. 2020), the authors train a FastText model on the Urban Dictionary dataset,<sup>1</sup> and evaluate these embeddings on both intrinsic tasks: Semantic Similarity and Clustering, and extrinsic tasks: Sentiment Analysis and Sarcasm Detection. In this work, we

<sup>1</sup><https://www.urbandictionary.com/>

train FastText embeddings using the skip-gram architecture on Urban Dictionary and Online Slang Dictionary data. To make predictions with the FastText embeddings on discriminative tasks, we use Random Forest and Linear SVC classifiers on all the evaluation datasets.

**BERT** Bidirectional Encoder Representations from Transformers (BERT) (Devlin et al. 2018) is a large language model that outputs textual embeddings conditioned on both left and right context. BERT models can be pretrained in an unsupervised manner to get general language representations that can be used for downstream tasks. BERT (Devlin et al. 2018) is trained in the formal English language from Wikipedia. As the BERT model has been largely trained on formal language in Wikipedia and Book Corpus, it can be anticipated to handle social media data sub-optimally. Thus, we also experiment with training a BERT model from scratch on slang-specific datasets.

**BERTTweet** As we expect that a BERT model trained on social media data is better equipped to capture slang language, we also experiment with the BERTTweet (Nguyen, Vu, and Nguyen 2020) model. BERTTweet is pretrained on a large corpus of Twitter data containing around 873M tweets ranging from 2010 to 2019. BERTTweet can be expected to capture the commonly occurring slang words, for example, the word "lol" would be correctly tokenized as "lol".

### Knowledge Sources

**Urban Dictionary (UD)** has been a standard source of slang in many works such as (Wilson et al. 2020), (Wu, Morstatter, and Liu 2016), and (Dhuliawala, Kanojia, and Bhattacharyya 2016). Urban Dictionary is a crowd-sourced collection of slang words along with their definitions and usage examples, containing over two million entries. Urban Dictionary, however, has its own demerits. The dictionary’s voting system and its low threshold to include the new content result in noisy and opinionated entries. A detailed exploratory study of the urban dictionary is presented in (Nguyen, McGillivray, and Yasseri 2017). For training our models, we only work with the usage examples from the Urban Dictionary. There are two usage examples for each word

Table 1: Examples from the evaluation datasets with corresponding labels.

Evaluation Task	Examples	Label
Sentiment Analysis	so much love for this woman, ughh #arianagrande Give it a listen! Raw project from one of the realest #blacklivesmatter Cannot believe people are attempting to sell a \$50 toy for 6x the price! Unbelievable! #Hatchimals #peoplesuck	positive neutral negative
Hate Speech Detection	There are NO INNOCENT people in detention centres #SendThemBack Libyan coast guard rescues some 160 #Europe-bound migrants	1 0
Offense Detection	You forget Eastern Europeans, who are the worst Dude.. Why r u trolling Ash rock z? He is our guy.. Just in a hurry to see bjp govt in state.	1 0

Table 2: Data Partitions of the Evaluation Datasets

Dataset	Train Size	Test Size
Sentiment Analysis	32084	8021
HateEval	8000	2000
OffenseEval	10592	2648

on average resulting in around 4 million data entries.

**Online Slang Dictionary (OSD)** contains fewer entries in comparison to the Urban Dictionary, around 15k in total.<sup>2</sup> OSD contains words/phrases, their meaning, and their usage in sentences. We extract the 12k entries from OSD that contain usage examples.

In addition to the Urban Dictionary and the Online Slang Dictionary, we also explore Green’s Dictionary of Slang.<sup>3</sup> Green’s Dictionary of Slang describes the origin of words and phrases. In our context, this data source is not useful as it does not contain any usage examples and hence is not included in the reported experiments. We also explored purely slang-based Twitter corpora from (Keidar et al. 2022). We experimented by retraining the BERTTweet model on this dataset to address the frequency of the slang words issue in the slang dictionaries dataset. However, the retrained model reported lower accuracy than that of the base BERTTweet model.

## Classifiers

We select commonly used classifiers such as Random Forest and Linear SVC to classify the FastText embeddings of the tweets in each of the evaluation tasks. Random Forest is an ensemble learning-based machine learning model that constructs multiple decision trees on the training data. The classification prediction of Random Forest is the class predicted by most decision trees. Linear SVC is a support vector machine-based classification model. This model tries to find the best hyperplane that maximizes the distance between the samples from different classes.

The first layers of the BERT model learn generic linguistic patterns and the last few layers learn task-specific patterns. For downstream tasks such as classification, the first layers are frozen and the last layers are trained.

<sup>2</sup><http://onlineslangdictionary.com/>

<sup>3</sup><https://greensdictofslang.com/>

## Experimental Setup

### Model Training Details

**Training setup** We train the FastText models in an unsupervised manner on UD and OSD data. To train the FastText models, we use the standard skip-gram architecture and fine-tune it over the training data of each task. We report the results from Random Forest as it performs slightly better than SVC, noting that the difference is negligible. The BERT model is pre-trained from scratch on the UD and OSD data with a masked language modeling objective. The BERTTweet model is re-trained on UD and OSD data and is fine-tuned on HateEval and OffenseEval datasets. BERT and BERTTweet are finetuned for the Sequence Classification task on the evaluation datasets.

For UD, we reuse the dataset provided by (Wilson et al. 2020) containing over 4 million usage entries of slang words and their usage examples. For OSD, we manually extract and clean the data entries resulting in a dataset of size 12k.

**Parameters** We train the FastText model for 10 epochs with an embedding dimension of 300. We use 100 estimators for random forest classifier and l2 penalty loss for Linear SVC. We finetune the BERTTweet model using the Adam optimizer with a learning rate of 1e-6 and cross-entropy loss for 5 epochs. We retrain the model only for 2 epochs as increasing the number of retraining epochs caused the model to distort its original knowledge acquired from the Twitter dataset by randomising the initial weights, leading to worse performance on the downstream tasks.

### Evaluation

**Evaluation tasks** We evaluate our models on three classification tasks: Sentiment Analysis, Hate Speech Detection, and Offense Detection. We select these tasks because slang terminology is central to comprehension of hateful, emotional, and offensive content in social media communication.

**Data** For *sentiment analysis*, we use the SemEval 2017 task 4 (Rosenthal, Farra, and Nakov 2017) dataset containing 50k training entries and 12k testing entries. SemEval 2019 (Basile et al. 2019) task 5 focuses on the detection of *hate speech* against women and immigrants with a dataset of 13k tweets in English. SemEval 2020 (Zampieri et al. 2020) task 12 describes the task of *offense detection* in social media with a dataset containing 15k entries. We show examples for each task with their corresponding labels in Table 1. We par-

tition the evaluation datasets by randomly holding out 20% of each dataset as validation dataset, and using the rest for training. Statistics per dataset are provided in Table 2.

We evaluate our models by using the customary metrics of precision, recall, and F1-score.

## Research Questions

1. **Do resulting models understand slang?** Large language models often perform well on the downstream classification tasks (Devlin et al. 2019; Brown et al. 2020). But can these models comprehend the quickly evolving slang in social media platforms and beyond, and can they leverage the slang terminology to detect inappropriate better? To answer these questions, we apply our framework and observe the performance of various combinations of language models and knowledge sources per task.
2. **Which language model is best equipped for understanding slang?** We compare static and contextual models, and we compare models that have been tuned to social media data to those that have not. We compare their performance and their qualitative behavior.
3. **Which knowledge source provides more useful knowledge for adapting models?** We evaluate various knowledge sources to see which source best helps the models capture the domain. Here, we compare two slang dictionaries with different sizes and content types against the vanilla models without direct slang source adaptation.
4. **Which cases are difficult for our models?** We closely examine the failure cases and hypothesize the potential causes for the model’s erratic behavior. We connect these failure categories intuitively to architectural and training decisions in the models and our framework.

## Results

### Main Results

We show the results of the different combinations of models and knowledge sources in Table 3. The BERTTweet model performs best in all the evaluation tasks. This is intuitive, as the model trained on tweets can be expected to capture the social media domain best and can give the best results on the evaluation datasets as they are also based on Twitter. This hypothesis is verified to be true by the results of the evaluation datasets. To confirm that the performance is owed to better coverage of slang, we test BERTTweet model manually on random sentences with slang words masked. We observe that this model has a relatively good command of words that are used as both slang and non-slang terms, e.g., for the sentence: *This place is amazing. It is [MASK]*, the [MASK] is predicted as “awesome”.

We also observe that the BERTTweet model trained on the initial Twitter dataset and retrained on the Urban Dictionary data does not show major improvements. This can be attributed to the low frequency of the slang words in the UD+OSD dataset, where each slang word occurs at most three-four times in the dataset. If the slang word is not commonly occurring in the pretrained tweet dataset, then the word is not captured by the BERT or BERTTweet models.

The FastText model trained only on usage examples from the UD or OSD data performs better than the baseline models for each task. These embeddings also capture the relationship between various slang words. Upon examining the top 10 nearest neighbors of commonly occurring slang words in the evaluation dataset, as shown in Table 4, we obtain the words “haha”, “kidding”, and “rofl” as nearest neighbors for “lol”. They are also able to capture the abbreviations in some cases: “nevermind” is the nearest neighbor to its abbreviation “nvm”, while “wazup” is the nearest neighbor to the phrase “what is up”.

The BERT uncased model trained on Wikipedia data gives better results on the evaluation datasets than the FastText models. But on a closer examination of the tokenization of the slang words in BERT, they are tokenized incorrectly. For example, “lol” is tokenized as “lo” and “l”, “slut” is tokenized as “s” and “lut” and so on, indicating that the model tokenizer fails to capture the slang domain, i.e., BERT often treats slang words as out-of-vocabulary terms. The BERT model trained on UD also fails to capture social media language. This can be due to the low frequency of slang words in the dataset. When this pretrained BERT model is tested on random sentences with the slang words masked, the model gives out nonsensical or no results. For the sentence: *This place is amazing. It is [MASK]*, the prediction for [MASK] is “”. For the sentence, *I got very angry at her. In the moment, i [MASK]-slapped her in my head.*, the model predicts the masked value as “and”. These results show that the model is unable to learn the context of the slang words. In terms of overall accuracy, this model yields similar results as the baseline BERT model on the evaluation datasets.

To overcome the incorrect tokenization of slang words by the BERT-based models, we also deliberately extend the BERTTweet tokenizer vocabulary with the slang words from the Online Slang Dictionary. This extension leads to an appropriate tokenization of the slang words, however, the model performance does not improve. The results of the extended model are shown in Table 5.

### Error Analysis

*Which cases are difficult for our models?* Through qualitative error analysis, we observe the misclassification occurs primarily due to five factors:

1. **Incorrect tokenization of infrequent terms.** Due to the low frequency of the slang words in the dataset, the BERT models do not tokenize the slang words as expected. Novel tokens such as “snatched” and “bae” are typically split into subtokens, which may influence their classification in a negative way, as they contain key information that is missed by the model.
2. **Tweets consisting mostly of URLs are misclassified.** This is because the content of the URL is not known without resolving it with an HTTP request. For example, the tweet *“Austria proposes sending troops abroad to stop migrant movement <https://t.co/cnxbFYdBU>, Immigration Jihad in action <https://t.co/VuFN3DktJ7>”* is difficult to classify without including the contents of the URL as additional context.

Table 3: Model performance evaluated on Sentiment Analysis, Hate speech and Offense detection.

Dataset	Model	Source	Accuracy	F1 score
Sentiment Analysis	FastText	-	0.620	<b>0.710</b>
	FastText	UD	0.644	0.636
	FastText	UD+OSD	0.650	0.642
	BERT	-	0.632	0.558
	BERT	UD	0.696	0.648
	BERTTweet	-	<b>0.704</b>	0.674
	BERTTweet	UD+OSD	0.701	0.650
HateEval	FastText	-	0.660	0.620
	FastText	UD	0.670	0.620
	FastText	UD+OSD	0.710	0.680
	BERT	-	0.774	0.743
	BERT	UD	0.795	0.744
	BERTTweet	-	0.824	0.802
	BERTTweet	UD+OSD	<b>0.856</b>	<b>0.814</b>
OffenseEval	FastText	-	0.710	0.550
	FastText	UD	0.720	0.570
	FastText	UD+OSD	0.710	0.540
	BERT	-	<b>0.778</b>	0.495
	BERT	UD	0.755	0.461
	BERTTweet	-	0.797	<b>0.675</b>
	BERTTweet	UD+OSD	0.797	<b>0.675</b>

Table 4: Top 5 nearest neighbours for FastText trained on Wikipedia and on slang dictionaries.

Word	Wikipedia	UD+OSD
lol	kidding	roflolmao
	hahaha	roflmao
	yeah	rofl
	hahahaha	haha
	thats	lofk
nvm	nvmc	bvm
	nvmd	tvm
	nvme	mvm
	nvs	nevermind
	nvmfs	nvr

Table 5: Evaluation of BERTTweet with an extended vocabulary.

Dataset	Acc	Precision	Recall	F1
Sentiment Analysis	0.685	0.581	0.633	0.606
HateEval	0.794	0.733	0.793	0.762
OffenseEval	0.758	0.620	0.652	0.635

3. **Polysemy between slang and non-slang words** such as "sick" and "cold" is difficult to cover for our models. For example, the word "sick" can be used with a negative, formal language, connotation: "I am feeling very sick", or a positive slang connotation "These beats are sick". Similarly, words like "woke" may be positive or negative depending on the context and the perspective of the author. Namely, a positive connotation of the term is used in

the sense of one being aware and proactive about current affairs, whereas in a negative sense woke is an oxymoron about people that express opinions about any mainstream topic in an attempt to gain attention. The polysemy and the contextual dependency makes it difficult for the models to capture the intent the slang words are associated with.

4. **Variance in spelling is non-trivial to handle for embedding models.** A common feature of a non-stabilized language, like slang or a dialect, is using a novel spelling of the word to emphasize the tone of the word or express emotion. An example is the infamous "heyyyy" that turned into a meme. Additionally, given that the language is informal, there is often no single correct way to spell a word: "wazzup", "wassup", "wasssssup", "wasup", and "sup" are all acceptable slang expressions.

## Discussion

In summary, we observe that models that are trained on large-scale social media data are most capable of understanding slang in downstream tasks. Slang-specific sources are mainly beneficial for static models that have been trained on Wikipedia corpora before. While out-of-vocabulary terms represent a key challenge for contextual models like BERT and BERTTweet, adapting these models or their tokenizers does not manifest in better performance in downstream reasoning tasks. Further issues relating to polysemy, variance in spelling, and annotation disagreements point to characteristics of the phenomenon of slang as a quickly evolving and subjective language, which we discuss next.

**Slang as a quickly evolving language** Internet linguistics accelerates the inherent property of language to evolve

over time. While the factors that influence language evolution are still hypothesized (Kolodny and Edelman 2018), it is apparent that this evolution is largely accelerated with the emergence of Internet linguistics (McCulloch 2020). The language on the Internet, expressed through novel forms including tweets and memes, leads to the quick evolution of expressions and the spreading of novel slang terms within communities, eventually forming an Internet folklore. On the one hand, this motivates the need for integrated AI solutions that mix many forms of Internet data: cultural tropes,<sup>4</sup> memes,<sup>5</sup> UD, Hatebase (Boyd 2022), and other forms of usage data. On the other hand, it is possible that slang can adapt very quickly to moderation and thus thwart this type of approach. In fact, it seems that slang and some memes are already specifically designed as euphemisms in order to “fly under the radar” of censorship, such as *Pepe the Frog*.<sup>6</sup> From this perspective, it would be interesting to measure the influence/endogeneity of moderation and censorship on slang, the speed of adaptation, and the real efficiency of moderation to stop the diffusion of inappropriate content.

**Slang as a subjective phenomenon** Tasks that involve hate speech or offense detection are inherently subjective and depend on the annotator’s demographics, knowledge, and experience. Prior work reports that disagreement for sentiment analysis ranges between 40–60% for low-quality annotations, and between 25–35% even for high-quality annotations (Kenyon-Dean et al. 2018). Rather than ignoring the disagreement and evaluating on the majority label, a more sophisticated idea is to train and evaluate AI methods that can handle and predict human disagreement (Kralj Novak et al. 2022). As suggested in (Kocoń et al. 2021), personalized models can be trained to detect and mimic individual or community profiles, thus treating the disagreement as a signal rather than noise. These models can be trained to explicitly model the psychological traits of the individual or group of annotators, inspired by the approach in (Bahgat, Wilson, and Magdy 2022).

## Related Work

(Wu, Morstatter, and Liu 2016) created a sentiment dictionary for slang words for sentiment analysis of social media data. (Dhuliawala, Kanojia, and Bhattacharyya 2016) built a WordNet-like resource for slang words and neologisms and the efficacy of this resource was evaluated over Word Sense Disambiguation algorithms for English social media data. (Wilson et al. 2020) explored generating slang embeddings for Urban Dictionary data using the FastText framework. These embeddings were evaluated on a variety of tasks such as Sentiment Analysis and Sarcasm Detection. (Davidson et al. 2017a) attempts to detect and identify slang in Twitter data by using LSTM-based networks with feature boosting. Automated tools that capture slang have been attempted to associate Web content (on social media) to the psychological traits of the writer (Bahgat, Wilson, and Magdy 2022). In our work, we explore static models such as

FastText and also state-of-the-art contextual large language models such as BERT and BERTTweet, comparing their performance across evaluation tasks. We closely examine the model’s failure cases and hypothesize the potential causes for these failures.

Many attempts have been made to understand social media language by detecting offense and hate in tweets and conversational data. (Zampieri et al. 2020) poses a challenge of multilingual hate speech detection in social media. (Davidson et al. 2017b) built an automated framework for hate speech detection and separation of hate speech from offensive language. (Caselli et al. 2020) retrains BERT model for abusive language detection in social media. Hate speech and offensive language often contain slang words. We evaluate our models on these tasks to verify if the language models capture slang words and their context.

## Conclusions

In this paper, we devised a slang understanding framework that combined language models and knowledge sources to help moderators better combat harmful, offensive, or inappropriate content on social media platforms. We applied this framework to three tasks that intuitively rely on slang language, observing that the best performance was obtained by Transformer language models that have been adapted to social media data, such as BERTTweet. Typically, slang usage repositories like Urban Dictionary improved the performance of embedding models that were not adapted to such data before. We found that retraining the models on social media or slang data did not bring consistent gain across tasks. Our error analysis identified five main challenges for slang understanding at scale: incorrect tokenization for infrequent words, presence of URLs, polysemy between formal and slang words, variance in spelling, and misclassifications in the ground truth data.

Our experiments point to two key aspects that need to be considered seriously in future work. First, Internet slang is an unprecedented form of language evolution that may be solvable by collecting a comprehensive collection of representative data, including memes, slang dictionaries, and usage data. The counterpoint to this data-driven approach is that slang and meme expressions may already be partially designed to avoid censorship, thus anticipating the data-driven solution. Second, as judging the harmfulness of online content is inherently subjective, we suggest a shift from the dominant practice of enforcing a single agreed perspective to the new and emerging practice of modeling disagreement as a signal rather than noise. This would lead to optimizing AI models to make decisions based on the perspectives of individuals or groups, rather than a single best decision.

## Acknowledgements

The first two authors have been supported by armasuisse Science and Technology, Switzerland under contract No. 8003532866.

<sup>4</sup>E.g., <https://tvtropes.org/>

<sup>5</sup>E.g., <https://knowyourmeme.com/>

<sup>6</sup>[https://en.wikipedia.org/wiki/Pepe\\_the\\_Frog](https://en.wikipedia.org/wiki/Pepe_the_Frog)

## References

- Adams, M. 2012. *Slang: The people's poetry*. Oxford University Press.
- Bahgat, M.; Wilson, S.; and Magdy, W. 2022. LIWC-UD: Classifying Online Slang Terms into LIWC Categories. In *14th ACM Web Science Conference 2022*, 422–432.
- Basile, V.; Bosco, C.; Fersini, E.; Nozza, D.; Patti, V.; Rangel Pardo, F. M.; Rosso, P.; and Sanguinetti, M. 2019. SemEval-2019 Task 5: Multilingual Detection of Hate Speech Against Immigrants and Women in Twitter. In *Proceedings of the 13th International Workshop on Semantic Evaluation*, 54–63. Minneapolis, Minnesota, USA: Association for Computational Linguistics.
- Biermann, F.; Kanie, N.; and Kim, R. E. 2017. Global governance by goal-setting: the novel approach of the UN Sustainable Development Goals. *Current Opinion in Environmental Sustainability*, 26: 26–31.
- Bojanowski, P.; Grave, E.; Joulin, A.; and Mikolov, T. 2016. Enriching Word Vectors with Subword Information.
- Boyd, D. 2022. Research summary document: hatebase-AI for hate speech monitoring.
- Brown, T.; Mann, B.; Ryder, N.; Subbiah, M.; Kaplan, J. D.; Dhariwal, P.; Neelakantan, A.; Shyam, P.; Sastry, G.; Askell, A.; et al. 2020. Language models are few-shot learners. *Advances in neural information processing systems*, 33: 1877–1901.
- Caselli, T.; Basile, V.; Mitrović, J.; and Granitzer, M. 2020. HateBERT: Retraining BERT for Abusive Language Detection in English.
- Chen, W.; Pacheco, D.; Yang, K.-C.; and Menczer, F. 2021. Neutral bots probe political bias on social media. *Nature communications*, 12(1): 1–10.
- Davidson, T.; Warmusley, D.; Macy, M.; and Weber, I. 2017a. Automated Hate Speech Detection and the Problem of Offensive Language.
- Davidson, T.; Warmusley, D.; Macy, M.; and Weber, I. 2017b. Automated Hate Speech Detection and the Problem of Offensive Language.
- Delisle, L.; Kalaitzis, A.; Majewski, K.; de Berker, A.; Marin, M.; and Cornebise, J. 2019. A large-scale crowd-sourced analysis of abuse against women journalists and politicians on Twitter. *arXiv preprint arXiv:1902.03093*.
- Devlin, J.; Chang, M.-W.; Lee, K.; and Toutanova, K. 2018. BERT: Pre-training of Deep Bidirectional Transformers for Language Understanding.
- Devlin, J.; Chang, M.-W.; Lee, K.; and Toutanova, K. 2019. BERT: Pre-training of Deep Bidirectional Transformers for Language Understanding. In *Proceedings of the 2019 Conference of the North American Chapter of the Association for Computational Linguistics: Human Language Technologies, Volume 1 (Long and Short Papers)*, 4171–4186. Minneapolis, Minnesota: Association for Computational Linguistics.
- Dhuliawala, S.; Kanojia, D.; and Bhattacharyya, P. 2016. SlangNet: A WordNet like Resource for English Slang.
- DiResta, R.; and Grossman, S. 2019. Potemkin pages & personas: Assessing GRU online operations, 2014-2019. *White Paper* <https://fsi-live.s3.us-west-1.amazonaws.com/s3fs-public/potemkin-pagespersonas-sio-wp.pdf>.
- Greenough, J. B.; and Kittredge, G. L. 1901. *Words and their ways in English speech*. Macmillan.
- Habib, H.; and Nithyanand, R. 2022. Exploring the Magnitude and Effects of Media Influence on Reddit Moderation. *Proceedings of the International AAAI Conference on Web and Social Media*, 16(1): 275–286.
- Keidar, D.; Opedal, A.; Jin, Z.; and Sachan, M. 2022. Slangvolution: A Causal Analysis of Semantic Change and Frequency Dynamics in Slang.
- Kenyon-Dean, K.; Ahmed, E.; Fujimoto, S.; Georges-Filteau, J.; Glasz, C.; Kaur, B.; Lalande, A.; Bhandari, S.; Belfer, R.; Kanagasabai, N.; et al. 2018. Sentiment analysis: It's complicated! In *Proceedings of the 2018 Conference of the North American Chapter of the Association for Computational Linguistics: Human Language Technologies, Volume 1 (Long Papers)*, 1886–1895.
- Khan, I. 2021. Report of the Special Rapporteur on the Promotion and Protection of the Right to Freedom of Opinion and Expression. [Undocs.org/en/A/76/258](https://undocs.org/en/A/76/258). Accessed: 2022-11-30.
- Kocoń, J.; Figas, A.; Gruza, M.; Puchalska, D.; Kajdanowicz, T.; and Kazienko, P. 2021. Offensive, aggressive, and hate speech analysis: From data-centric to human-centered approach. *Information Processing & Management*, 58(5): 102643.
- Kolodny, O.; and Edelman, S. 2018. The evolution of the capacity for language: the ecological context and adaptive value of a process of cognitive hijacking. *Philosophical Transactions of the Royal Society B: Biological Sciences*, 373(1743): 20170052.
- Kralj Novak, P.; Scantamburlo, T.; Pelicon, A.; Cinelli, M.; Mozetič, I.; and Zollo, F. 2022. Handling Disagreement in Hate Speech Modelling. In *International Conference on Information Processing and Management of Uncertainty in Knowledge-Based Systems*, 681–695. Springer.
- Mamié, R.; Horta Ribeiro, M.; and West, R. 2021. Are anti-feminist communities gateways to the far right? evidence from reddit and youtube. In *13th ACM Web Science Conference 2021*, 139–147.
- McCulloch, G. 2020. *Because internet: Understanding the new rules of language*. Penguin.
- Nguyen, D.; McGillivray, B.; and Yasseri, T. 2017. Emo, Love, and God: Making Sense of Urban Dictionary, a Crowd-Sourced Online Dictionary.
- Nguyen, D. Q.; Vu, T.; and Nguyen, A. T. 2020. BERTweet: A pre-trained language model for English Tweets.
- Partridge, E. 2015. *Slang: To-day and yesterday*. Routledge.
- Rosenthal, S.; Farra, N.; and Nakov, P. 2017. SemEval-2017 Task 4: Sentiment Analysis in Twitter. In *Proceedings of the 11th International Workshop on Semantic Evaluation (SemEval-2017)*, 502–518. Vancouver, Canada: Association for Computational Linguistics.

Tomašev, N.; Cornebise, J.; Hutter, F.; Mohamed, S.; Picciarriello, A.; Connelly, B.; Belgrave, D.; Ezer, D.; Haert, F. C. v. d.; Mugisha, F.; et al. 2020. AI for social good: unlocking the opportunity for positive impact. *Nature Communications*, 11(1): 1–6.

Wilson, S.; Magdy, W.; McGillivray, B.; Garimella, K.; and Tyson, G. 2020. Urban Dictionary Embeddings for Slang NLP Applications. In *Proceedings of the 12th Language Resources and Evaluation Conference*, 4764–4773. Marseille, France: European Language Resources Association. ISBN 979-10-95546-34-4.

Wu, L.; Morstatter, F.; and Liu, H. 2016. SlangSD: Building and Using a Sentiment Dictionary of Slang Words for Short-Text Sentiment Classification.

Zampieri, M.; Nakov, P.; Rosenthal, S.; Atanasova, P.; Karadzhov, G.; Mubarak, H.; Derczynski, L.; Pitenis, Z.; and Çöltekin, Ç. 2020. SemEval-2020 Task 12: Multilingual Offensive Language Identification in Social Media (OffensEval 2020). In *Proceedings of the Fourteenth Workshop on Semantic Evaluation*, 1425–1447. Barcelona (online): International Committee for Computational Linguistics.