

GitFL: Adaptive Asynchronous Federated Learning using Version Control

Ming Hu[†], Zeke Xia[‡], Zhihao Yue[‡], Jun Xia[‡], Yihao Huang[†], Yang Liu[†], and Mingsong Chen^{*‡}

[†]Nanyang Technological University, Singapore

[‡]East China Normal University, Shanghai, China

Abstract—As a promising distributed machine learning paradigm that enables collaborative training without compromising data privacy, Federated Learning (FL) has been increasingly used in AIoT (Artificial Intelligence of Things) design. However, due to the lack of efficient management of stragglers, existing FL methods greatly suffer from the problems of low inference accuracy and long training time. Things become even worse when taking various uncertain factors (e.g., network delays, performance variances caused by process variation) existing in AIoT scenarios into account. To address this issue, this paper proposes a novel asynchronous FL framework named GitFL, whose implementation is inspired by the famous version control system Git. Unlike traditional FL, the cloud server of GitFL maintains a master model (i.e., the global model) together with a set of branch models indicating the trained local models committed by selected devices, where the master model is updated based on both all the pushed branch models and their version information, and only the branch models after the pull operation are dispatched to devices. By using our proposed Reinforcement Learning (RL)-based device selection mechanism, a pulled branch model with an older version will be more likely to be dispatched to a faster and less frequently selected device for the next round of local training. In this way, GitFL enables both effective control of model staleness and adaptive load balance of versioned models among stragglers, thus avoiding the performance deterioration. Comprehensive experimental results on well-known models and datasets show that, compared with state-of-the-art asynchronous FL methods, GitFL can achieve up to 2.64X training acceleration and 7.88% inference accuracy improvements in various uncertain scenarios.

Index Terms—AIoT, Federated Learning, Asynchronous Aggregation, Uncertainty, Reinforcement Learning, Version Control

I. INTRODUCTION

Along with the prosperity of Artificial Intelligence of Things (AIoT), we are Federated Learning (FL) [1], [2] is becoming more and more popular in the design of AIoT applications, e.g., autonomous driving, industrial automation, and control [3], commercial surveillance, and healthcare systems [4]. As an promising collaborative learning paradigm, FL adopts a cloud-based architecture, where AIoT devices focus on local training based on their own data while the cloud server is responsible for both knowledge aggregation and dispatching. Although FL enables knowledge sharing among AIoT devices without compromising data privacy, existing FL methods inevitably suffer from the problems of low inference performance and long overall training time. Generally, a typical

AIoT system involves a variety of heterogeneous devices, which have different computation and communication capabilities (e.g., CPU/GPU frequencies, memory size, network bandwidths) and specified workloads (e.g., the number of data samples, data distributions). In this case, devices with weaker performance (a.k.a., *stragglers*) will take much longer local training time than the other selected devices. This is quite harmful to the most widely-used synchronous FL methods such as Federated Average (FedAvg) [5], which requires that the cloud server should wait for the responses from all the selected devices before aggregation. According to the “wooden barrel theory”, when applying synchronous FL methods, the training time of one FL communication round will be determined by the slowest selected devices. As a result, the existence of stragglers will significantly slow down the process of overall FL training.

To mitigate the shortcomings caused by stragglers in synchronous FL, various asynchronous FL methods (e.g., FedAsync [6], HADFL [7] and Helios [8]) have been investigated. Unlike synchronous FL, in each training round the asynchronous cloud server performs an update of the global model once it receives a local model from some device. However, due to different participating frequencies of devices in asynchronous updating, the stale local models trained by stragglers can easily result in poor training quality, especially for non-IID (Independent Identically Distribution) scenarios. As a trade-off between synchronous and asynchronous FL methods, by forcing to synchronize multiple stale local models in one training round, semi-asynchronous FL methods (e.g., SAFA [9] and FedSA [10]) can be used to partially alleviate the model staleness issue. However, such semi-asynchronous FL methods also bring new problems. For example, due to the large staleness discrepancies, the cloud server may frequently synchronize with some stragglers before they complete their local training. In this case, the stragglers may not have a chance to participate in global model updating, thus biasing the training of global models. Thing becomes even worse when taking various uncertain factors in AIoT scenarios into account, since both asynchronous and semi-asynchronous FL methods assume that the performance metrics (e.g., network delay and computation capacities) of AIoT devices are fixed. However, this is not true in practice. For example, due to process variation during the manufacturing of microelectronic circuits, the performance of devices with the same type varies

*Corresponding Author.

significantly [11]. Due to the over-pessimistic estimation of the performance metrics, the potential of asynchronous FL is strongly suppressed. Clearly, due to the lack of efficient management mechanisms for stale models within an uncertain environment, it is hard for existing asynchronous FL methods to quickly converge to a higher inference performance.

Inspired by the implementation of Git, a famous version control system, this paper proposes a novel asynchronous FL approach named GitFL, which enables efficient management of straggler devices to accommodate various uncertainties in an adaptive manner. Unlike traditional FL methods, GitFL does not dispatch its global model directly to its selected devices for local training. Instead, it keeps a set of branch models that can traverse different devices asynchronously, and dispatches new branch models pulled from the global model to devices. Here, the global model is only used to accumulate the versioned knowledge obtained by the branch models. To support the adaptive load balance of version models on straggler devices, GitFL is apt to dispatch a pulled branch model with an older version to a faster and less frequently device for the next round of local training. In summary, this paper makes the following three major contributions:

- Based on the push/pull operations, we established a novel Git-like asynchronous FL framework, which supports both effective management of straggler devices and version control of their stale models within an uncertain environment.
- We develop a new Reinforcement Learning (RL)-based curiosity-driven exploration method to support the wise selection of straggler devices in an adaptive manner. Our approach enables the load balance of versioned models among AIoT devices, thus avoiding the performance deterioration caused by stragglers.
- We conduct experiments on both well-known datasets and models to show the effectiveness of our approach in terms of convergence rate and inference performance for both IID and non-IID scenarios.

The rest of this paper is organized as follows. Section II introduces the backgrounds and related work of existing FL methods. Section III details the implementation of our GitFL approach. Section IV gives the experimental results. Finally, Section V concludes this paper.

II. BACKGROUNDS AND RELATED WORK

A. Preliminaries to FL

The traditional FL framework consists of a central cloud server and multiple clients. The cloud server maintains a global model for FL training. In each FL training round, the cloud server dispatches the global model to multiple clients. Then, each client uses its local data for local training and uploads the trained model to the cloud server. Finally, the cloud server generates a new global model by aggregating all the uploaded

models. Typically, the model aggregation is based on FedAvg [5], which is defined as follows:

$$\begin{aligned} \min_w F(w) &= \frac{1}{K} \sum_{k=1}^K f_k(w), \\ \text{s.t.}, f_k(w) &= \frac{1}{|d_k|} \sum_{i=1}^{|d_k|} \ell(w, \langle x_i, l_i \rangle), \end{aligned} \quad (1)$$

where K is the number of clients that participate in local training, d_k is the dataset of the k^{th} client, the $|d_k|$ denotes the number of data samples in d_k , ℓ denotes the customer-defined loss function (e.g., cross-entropy loss), $\langle x_i, y_i \rangle$ denotes a sample x_i with its label l_i .

B. FL on Heterogeneous Devices

To deal with the straggler issue caused by heterogeneous devices, there are numerous optimization FL methods based on synchronous and asynchronous architectures. For example, in [8], Xu *et al.* proposed a synchronous FL method Helios, which accelerates the training speed of stragglers by adaptive reducing model parameters. In [6], Xie *et al.* proposes an asynchronous federated learning framework FedAsync, in which the cloud server aggregates the uploaded model with the global model in real time according to the staleness of nodes. In [9], Wu *et al.* proposes a semi-asynchronous FL method SAFA, which uses a cache structure to bypass uploaded models according to their versions for model aggregation. Similarly, in [10], Ma *et al.* sets a model buffer for model aggregation to achieve semi-asynchronous FL. Although these methods can alleviate the problem of stragglers, they do not consider uncertain environments.

To the best of our knowledge, GitFL is the first attempt to use a version control mechanism for asynchronous FL and an RL-based client selection strategy to enable the load balance of versioned models among AIoT devices and adaptation to uncertain environments. Compared with state-of-the-art FL methods, our GitFL approach can achieve the best test convergence rate and inference performance for both IID and non-IID scenarios.

III. OUR GITFL APPROACH

A. Overview

Figure 1 presents the framework and workflow of our GitFL approach, which consists of a central cloud server and multiple clients. The cloud server contains two key components, i.e., the model version controller and the RL-based client selector. The model version controller updates the master model and branch models asynchronously according to the version of each branch model. The RL-based client selector chooses clients for local training according to the number of past selections, historical training time, and the version of the dispatched branch model.

The model version controller includes a model repository to store all the branch models with its version, an uploaded queue to receive trained branch models, and a dispatched queue for

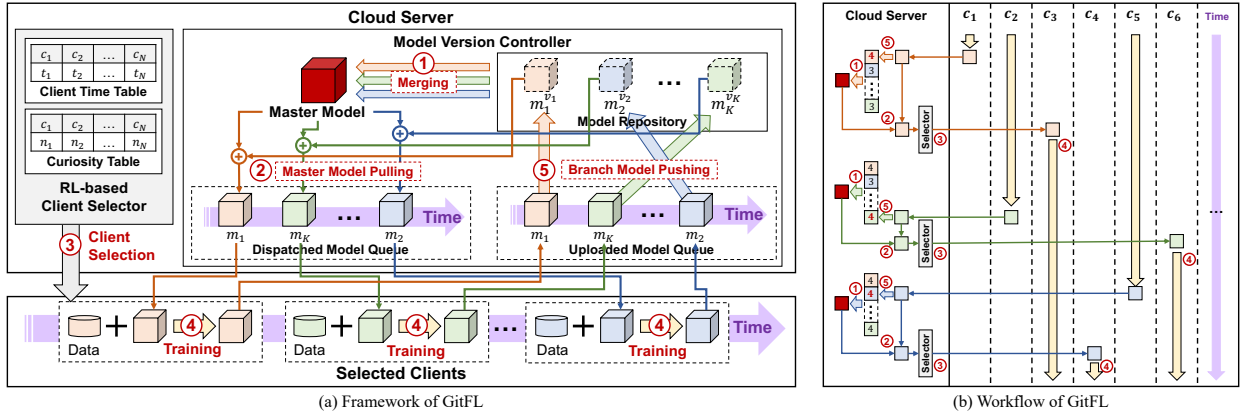

Fig. 1. Framework and workflow of GitFL.

assigning updated branch models. The RL-based client selector consists of a client time table and a count table, respectively. The client time table records the training time of each client and the count table records the selected number of each client. In detail, to perform timekeeping for each model, it starts when the target model is assigned to local clients from the dispatched model queue. After the model is trained in local clients and pushed to the uploaded model. The update of tables is in real-time. With the help of these two tables, the client selector can prompt all clients adequately participate in training, thus reducing the version difference between branch models. Please note that the selection strategy is according to the version of a target branch model and the two tables which record the operating efficiency of local clients. The branch model with a higher version is preferred to assign to a client with a longer training time, and vice versa. For a model with a medium version, the selector prefers to select the client with less number of selections.

Each iteration of a branch model in GitFL includes five key steps: i) model merging, the controller updates the dispatched branch model by merging it with the new master model and pushing it into the dispatched model queue; ii) model pulling, the controller updates the dispatched branch model by merging it with the new master model and pushing it into the dispatched model queue; iii) client selection, the client selector selects a client for branch model dispatching; iv) local training, the selected client trains the received branch model using its local data; and v) model pushing, the controller pushes the branch model into the repository and updates its version.

B. GitFL Implementation

Algorithm 1 presents the implementation of our GitFL approach. We assume that there are at most K clients participating in local training at the same time, which means that GitFL adopts K branch models for local training. Line 2 initializes the model repository R , which is a list to store all the branch models. Line 3 initializes a list V , which records the version of all the branch models. Line 4 initializes the count table T_c and the client time table T_t . Line 5 sets the function $Time()$ to record the start time of FL training and is used to get the timestamp in real time. Lines 7-21 presents the

Algorithm 1: Implementation of GitFL

Input: i) T , training time; ii) C , the set of clients; iii) K , # of clients participating in local training.

Output: m_g , the global model.

```

1 GitFL( $T, C, K$ ) begin
2    $R \leftarrow [m_1, m_2, \dots, m_K]$ ;
3    $V[k] \leftarrow 0$  for  $k \in [1, K]$ ;
4    $T_c[i], T_t[i] \leftarrow 0$  for  $i \in [1, |C|]$ ;
5    $T_{start} \leftarrow Time()$ ;
6   /*parallel for*/
7   for  $i = 1, \dots, K$  do
8     while  $Time() - T_{start} < T$  do
9        $M \leftarrow Merging(R, V)$ ; // Model Merging
10       $m_i \leftarrow ModelPull(i, V, M, R[i])$ ; // Model Pulling
11       $c \leftarrow ClientSel(i, V, T_c, T_t, C)$ ; // Client Selection
12       $t_{start} \leftarrow Time()$ ;
13       $m_i \leftarrow LocalTrain(c, m_i)$ ; // Model Training
14       $t_{end} \leftarrow Time()$ ;
15       $t \leftarrow t_{end} - t_{start}$ ;
16       $V[i] \leftarrow V[i] + 1$ ;
17       $R[i] \leftarrow m_i$ ; // Model Pushing
18       $T_c[c] \leftarrow T_c[c] + 1$ ;
19       $T_t[c] \leftarrow \frac{(T_c[c]-1) \times T_t[c] + t}{T_c[c]}$ ;
20    end
21  end
22   $m_g \leftarrow Merging(R, V)$ ;
23  return  $m_g$ ;
24 end

```

FL training process of K branch models, where the “for” loop is a parallel loop. Lines 8-20 present the detail of each branch model training process. In Line 9, the function $Merging()$ merges all the branch models in R to generate a master model M . In Line 10, the function $ModelPull()$ pulls down the master model to aggregate with the i^{th} branch model according to the version list V , where m_i is the aggregated model. In Line 11, the function $ClientSel()$ selects a client according to T_c , T_t , and the version of a dispatched branch model. Line 13 dispatches the branch model to the selected client for local training. In Line 12, t_{start} uses the timestamp to record the dispatching operation of a branch model. In Line 14, t_{end} uses the timestamp to record the receiving operation of a branch model. In Line 15, t records the time of a whole local training process of a specified branch model, which includes the time of network communication and local model training. After receiving the branch model, Line 16 updates its version and Line 17 pushes it to the model repository. In addition, Line 18 and Line 19 update T_c and T_t , respectively.

C. Model Version Control

GitFL adopts a model version control strategy to guide knowledge sharing between the master model and branch models, which consists of three key operations, i.e., model merging, model pulling, and model pushing. To implement version control, GitFL sets a model repository that stores all branch models and their version information.

1) *Model Merging*: GitFL generates the master model by merging all branch models in the model repository. Since the branch model with a lower version may reduce the performance of the master model, GitFL gives each branch model a weight based on its version to guide the merging. The merging process is shown as follows:

$$Merging(R, V) = \frac{\sum_{k=1}^K R[k] \times V[k]}{\sum_{k=1}^K V[k]} \quad (2)$$

where R denotes the model repository, K presents the number of branch models, and V is the list of version information. Here, we directly use model versions as the merging weights instead of the difference of versions. At the beginning of training, models with a higher version should dominate the merging, since they are more accurate. At this time, either model versions or differences of versions are both reasonable to be used as weights. However, along with the progress of FL training, all the models are becoming well-trained. At this time, we expect all the models are adequately participating in the merging. Compared with differences of versions, model versions are more likely to equally merge the models.

2) *Model Pulling*: To enable knowledge sharing across branch models, each branch model needs to pull down the master model before model dispatching. In each pulling step, GitFL updates a branch model by aggregating it with the master model, and the aggregation weight depends on the version of this branch model. Here, a branch model with a higher version will be assigned a larger weight. This is because, on the one hand, the models with higher versions are more likely to be well-trained, which means they only need less knowledge from the master model. On the other hand, the knowledge of stragglers contained in the master model may have negative effects on the models with higher versions. For a model with a lower version, due to insufficient training, it needs to learn more knowledge from the master model. Therefore, it is assigned a fewer weight in aggregation. Based on the above consideration, GitFL uses a version control variable to guide the aggregation as follows:

$$v_{ctrl}^i = V[i] - \frac{1}{K} \sum_{k=1}^K V[k] \quad (3)$$

where i denotes the index of a branch model. v_{ctrl}^i denotes the difference between the version of i^{th} branch model and the average version of all branch models. By using the

version control variable, the model-pulling process is defined as follows:

$$ModelPull(i, V, M, m_i) = \frac{max(10 + v_{ctrl}^i, 2) \times m_i + M}{max(10 + v_{ctrl}^i, 2) + 1} \quad (4)$$

where M is the master model generated by Equation (2). Note that the excessive weight of the master model in model pulling makes the update of a branch model too coarse-grained, which may lead to the gradient divergence problem. Therefore, we set the weight of each branch model greater than that of the master model, which enables the branch model to acquire knowledge from the master model more smoothly and fine-grained.

3) *Model Pushing*: When the uploaded queue receives a trained branch model, the model version controller pushes this received branch model to the model repository and updates its version information. As shown in Figure 1(b), after receiving the model m_K , the model repository updates the version of m_K from 3 to 4. In addition, the model repository will replace the old version of a model with the new one. Note that for each branch model, the model repository only reserves the latest version. Therefore, in GitFL, the model repository only stores K models.

D. RL-based Client Selection

Although GitFL uses the master model as a bridge to implement asynchronous training of branch models, due to the uncertainty of clients and network, the version gaps between branch models lead to a low-performance problem. To balance the versions of branch models, we design a reinforcement learning strategy to select clients based on the branch model version, the historical training time of clients, and the selection number of clients.

1) *Problem Definition*: In GitFL, the client selection process can be defined as a Markov Decision Process (MDP), which is presented as a four-tuple $M = \langle \mathcal{S}, \mathcal{A}, \mathcal{F}, \mathcal{R} \rangle$ as follows:

- \mathcal{S} is a set of states. We use a vector $s = \langle B_m, V, C_t, T_c \rangle$ to denote the state of GitFL, where B_m denotes the set of branch models that waits for dispatching, V is the list of version information for all the branch models, C_t indicates the set of clients for current local training, and T_c is a table that records the selection number of all the clients.
- \mathcal{A} is a set of actions. At the state of $s = \langle i, V \rangle$, the action a aims to dispatch the i^{th} branch model to the selected client. The selection space of \mathcal{A} is all the clients in \mathcal{C} .
- \mathcal{F} is a set of transitions. It records the transition $s \xrightarrow{a} s'$ with the action a .
- \mathcal{R} is the reward function. Here, we combine the selection number and training time as the reward to evaluate the quality of a selection.

2) *Version- and Curiosity-Driven Client Selection*: GitFL adopts a version- and curiosity-driven strategy to evaluate rewards. The client selector prefers to select a client with a higher reward.

The version-driven strategy is used to balance the version differences between branch models. For the branch model with a lower version, we prefer to dispatch it to an efficient client (i.e., less training time) and vice versa. GitFL uses a client time table T_t to record the average historical training time of each client. When the i^{th} branch model is waiting for dispatching, the version reward for the client c is measured as follows:

$$R_v(c, i) = (V[i] - \frac{\sum_{k=1}^K V[k]}{K}) (\frac{T_t[c] - \frac{\sum_p^{|C|} T_t[p]}{|P|}}{\max(T_t)}), \quad (5)$$

where $|C|$ denotes the number of clients, $T_t[c]$ indicates the average historical training time of c . The difference between the model version and the average version determines the scope of R_v . Note that, the client selection is independent of client training time when the version of a branch model is equal to the average version.

To ensure the adequacy of client selection, we exploit curiosity-driven exploration [12] as one of the strategies to evaluate rewards, while the client with a less number of selections will get a higher curiosity reward. GitFL uses the count table T_c to record the selection number of each client and uses Model-based Interval Estimation with Exploration Bonuses (MBIE-EB) [13] to measure the curiosity reward for the client c as follows:

$$R_c(c, i) = \frac{1}{\sqrt{T_c[c]}}, \quad (6)$$

where $T_c[c]$ indicates the selection number of c . Note that the initialize value of $T_c[c]$ is 1. The reward of each client is measured by combining R_v and R_c as follows:

$$R(c, i) = \max(0, R_v(c, i) + R_c(c, i)). \quad (7)$$

If the difference between the model version and the average version is high, the reward will be mainly determined by the version reward. If the model version is close to the average version, the reward will be mainly determined by the curiosity reward. Note that the minimum value of a reward is 0. If the reward of a client equals 0, the client will not be selected. Otherwise, based on the above reward definition, the client selector chooses a client for model dispatching with the probability defined as follows:

$$P(c, i) = \frac{R(c, i)}{\sum_{j=1}^{|C|} R(j, i)}. \quad (8)$$

IV. PERFORMANCE EVALUATION

To evaluate the effectiveness of our approach, we implemented GitFL using the PyTorch framework. We compared our GitFL method with both classical FedAvg [5] and three state-of-the-art FL methods (i.e., FedAsync [6], SAFA [9], and FedSA [10]), where the former two are asynchronous and the latter two are semi-asynchronous. For SAFA and FedSA, we set the model buffer size to half the number of active clients. To enable fair comparison, we used an SGD optimizer with a learning rate of 0.01 and a momentum of 0.5 for both all the baselines and GitFL. For each client, we set the batch

size to 50 and performed five epochs for each local training. All the experimental results were obtained from an Ubuntu workstation with an Intel i9 CPU, 64GB memory, and an NVIDIA RTX 3090 GPU.

A. Experimental Settings

1) *Settings of Uncertainties*: We considered two kinds of uncertainties, i.e., the uncertainty of devices computation time caused by process variation [11], and the uncertainty caused by network delay. In the experiment, we assumed that both of them follow the Gaussian distributions. Table I shows the settings of both uncertainties, which are simulated in the FL training processes of experiments. Here, we assume that there exist five kinds of devices and five communication channels. Generally, devices and communication channels with higher quality have better computation and communication performance with lower variances as specified in the table.

TABLE I
SETTINGS FOR DEVICES AND THEIR COMMUNICATION

Quality	Device Settings	Network Settings
Excellent	$N(100, 5)$	$N(10, 1)$
High	$N(150, 10)$	$N(15, 2)$
Medium	$N(200, 20)$	$N(20, 3)$
Low	$N(300, 30)$	$N(30, 5)$
Critical	$N(500, 50)$	$N(80, 10)$

2) *Settings of Datasets and Models*: We compared the performance of GitFL and four baselines on three well-known datasets, i.e., CIFAR-10, CIFAR-100 and FEMNIST [14]. To investigate the performance of GitFL on non-IID scenarios, we adopted the Dirichlet distribution $Dir(\alpha)$ to control the heterogeneity of client data when using CIFAR-10 and CIFAR-100 datasets, where a smaller value of α indicates a higher data heterogeneity on devices. Note that we did not apply $Dir(\alpha)$ on FEMNIST dataset, since FEMNIST itself is naturally non-IID distributed. For the experiments on datasets CIFAR-10 and CIFAR-100, we assumed each of them involves 100 AIoT devices in total and in each FL round there were only 10 of them selected for local training at the same time. However, for dataset FEMNIST, there are a total of 180 devices and each FL round involves 18 devices selected for local training. Moreover, to show the pervasiveness of our GitFL framework, we also take three DNN models (i.e., CNN, ResNet-18 and VGG-16) with different sizes and structures into account.

B. Performance Comparison

1) *Comparison of Accuracy*: Table II compares the test accuracy between GitFL and all the baselines on three datasets with different non-IID and IID settings using ResNet-18 model. From this table, we can find that GitFL can achieve the highest accuracy for all the cases. As an example of dataset CIFAR-10, when $\alpha = 0.1$, GitFL can achieve an improvement of 7.88% over the best inference result obtained by FedSA.

Figure 2 presents the trend of learning for all the FL methods on CIFAR-10 based on ResNet-18 model. We can observe that a significant accuracy improvement was made by GitFL in all the non-IID and IID scenarios. Moreover, we can

TABLE II
COMPARISON OF TEST ACCURACY FOR BOTH IID AND NON-IID SCENARIOS

Dataset	Heterogeneity Settings	Test Accuracy (%)				
		FedAvg [5]	FedAsync [6]	SAFA [9]	FedSA [10]	GitFL (Ours)
CIFAR-10	$\alpha = 0.1$	42.87 \pm 5.32	46.48 \pm 2.14	41.21 \pm 3.42	46.97 \pm 3.33	54.85 \pm 0.92
	$\alpha = 0.5$	61.07 \pm 0.48	62.40 \pm 0.51	56.46 \pm 0.89	62.56 \pm 0.32	70.36 \pm 0.20
	$\alpha = 1.0$	63.42 \pm 0.63	65.08 \pm 0.29	59.75 \pm 0.29	66.55 \pm 0.16	72.65 \pm 0.18
	IID	64.80 \pm 0.13	64.89 \pm 0.12	62.72 \pm 0.19	65.82 \pm 0.15	72.40 \pm 0.15
CIFAR-100	$\alpha = 0.1$	34.41 \pm 0.45	34.88 \pm 0.67	30.42 \pm 0.57	35.77 \pm 0.46	40.61 \pm 0.28
	$\alpha = 0.5$	41.76 \pm 0.32	42.82 \pm 0.32	37.61 \pm 0.76	42.53 \pm 0.40	47.63 \pm 0.22
	$\alpha = 1.0$	42.08 \pm 0.23	43.08 \pm 0.67	38.90 \pm 0.33	43.32 \pm 0.17	48.86 \pm 0.23
	IID	43.04 \pm 0.16	43.40 \pm 0.31	40.84 \pm 0.22	43.39 \pm 0.14	49.26 \pm 0.14
FEMNIST	—	82.58 \pm 0.32	82.29 \pm 0.91	74.68 \pm 1.40	82.63 \pm 0.36	83.17 \pm 0.10

TABLE III
COMPARISON OF TRAINING TIME AND COMMUNICATION OVERHEAD TO ACHIEVE GIVEN TARGET INFERENCE ACCURACY

Heterogeneity Settings	Acc. (%)	FedAvg [5]		FedAsync [6]		SAFA [9]		FedSA [10]		GitFL	
		Time	Comm.	Time	Comm.	Time	Comm.	Time	Comm.	Time	Comm.
$\alpha = 0.1$	40	162203	3050	71566	2610	231008	6809	35067	1018	45770	1880
	45	-	-	237357	8645	-	-	191477	5538	72418	3000
$\alpha = 0.5$	55	40267	740	34400	1250	158434	4675	20532	608	16884	640
	60	214392	3990	114673	4155	-	-	103915	3033	24192	950
$\alpha = 1.0$	59	46584	880	25608	945	172888	5103	20774	608	16685	630
	64	269044	5050	140430	5135	-	-	85616	2493	25641	1010
IID	60	19738	360	13091	445	75217	2203	13375	408	12081	440
	64	43489	800	27196	1030	-	-	22476	678	15131	570

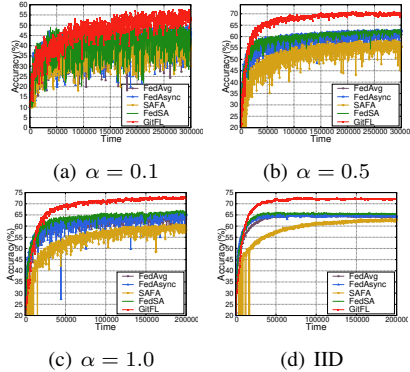

Fig. 2. Learning curves of GitFL and four baseline methods on CIFAR-10 find that under an extreme non-IID scenario with $\alpha = 0.1$, the learning curve of GitFL is more stable than the ones of all the other baselines.

2) *Comparison of Training Time and Communication Overhead*: Given a specific overall FL training target in terms of accuracy, Table III compares the training time and communication overhead between GitFL and all the baselines. From this table, we can find that from the perspective of training time GitFL outperforms all the baselines in seven out of eight cases. From the perspective of communication overhead, GitFL outperforms all the baselines in four out of eight cases. Note that here all the four cases indicate the higher accuracy targets of different settings, respectively. In other words, when the accuracy target becomes higher, our approach uses much less training time and communication overhead than the other baselines. As an example of dataset CIFAR-10, when $\alpha = 0.1$ and the target accuracy is 45%, GitFL outperforms FedSA by 2.64X and 1.85X in terms of training time and communication overhead, respectively. Note that in this case, FedSA has the second-best result.

C. Impacts of Different Configurations

We checked the impacts of different configurations on GitFL from the following three perspectives: different compositions of involved devices, different number of simultaneously training clients, different types of underlying AI models.

TABLE IV
DIFFERENT CONFIGURATIONS OF DEVICE COMPOSITION

Configuration	Type	# of Clients				
		Excellent	High	Medium	Low	Critical
Config. 1	Training	40	30	10	10	10
	Comm.	40	30	10	10	10
Config. 2	Training	10	20	40	20	10
	Comm.	10	20	40	20	10
Config. 3	Training	10	10	10	30	40
	Comm.	10	10	10	30	40
Config. 4	Training	40	10	0	10	40
	Comm.	40	10	0	10	40

1) *Impact of Different Device Compositions*: Table IV presents the four configurations for different devices used in the experiments, where the device settings are provided in Table I. Note that in each configuration, we do not force the devices with better settings to be equipped with communication modules with higher quality.

Figure 3 presents the learning curves of the four device composition configurations, where we applied GitFL (with ResNet-18 model) on dataset CIFAR-10 with IID distribution. From Figure 3, we can find that GitFL achieves the highest inference performance for all the four device compositions. Note that we can observe similar trends of learning curves for non-IID scenarios.

2) *Impact of Different Number of Simultaneously Training Clients*: To investigate the impacts of the number of simultaneously training clients on GitFL, we considered four cases, where the numbers of simultaneously training clients are 5, 10, 20, and 50, respectively. Figure 4 shows all experimental results conducted on CIFAR-10 with IID distribution using ResNet-18. From this figure, we can find that GitFL achieves

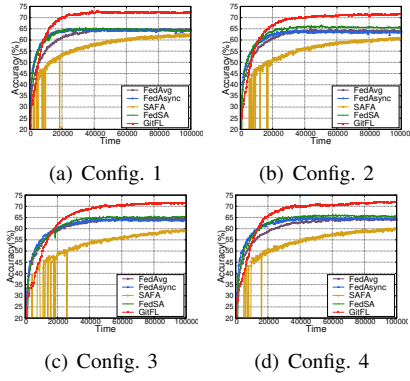

Fig. 3. Learning curves for different device composition configurations

the highest accuracy with all the settings. Especially, when more clients are involved in simultaneous training, the more improvements GitFL can obtain compared with baseline methods.

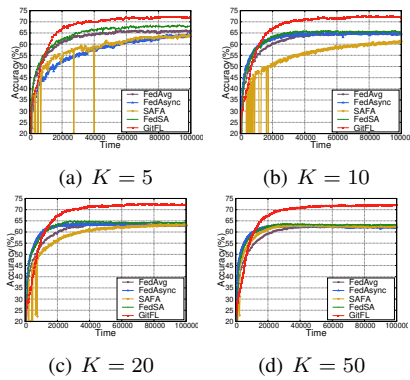

Fig. 4. Learning curves for different number of simultaneously training clients

3) *Impacts of AI Model Types:* We investigate two GitFL variants with different underlying AI models, i.e., CNN and VGG-16. Figure 5 shows the impacts of such two variants with different data distributions (i.e., non-IID with $\alpha = 0.1$ and IID). From this figure, we can find that GitFL achieves the highest accuracy in all the cases regardless of underlying AI model types or data distributions.

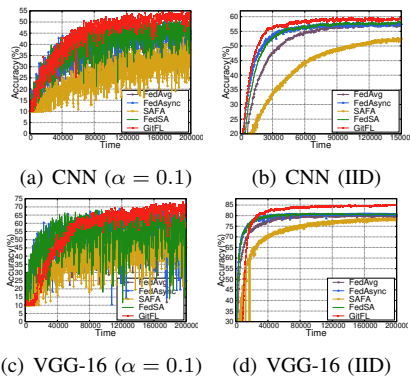

Fig. 5. Learning curves of GitFL variants on CIFAR-10

D. Ablation Study

To demonstrate the effectiveness of our RL-based client selection strategy, we developed three variants of GitFL: i)

“GitFL+R” that selects clients for local training in a random manner; ii) “GitFL+C” that selects clients only based on curiosity reward (see Equation 6); and iii) “GitFL+V” that selects clients only using version reward (see Equation 5). To facilitate understanding, we use “GitFL+CV” to indicate the full version of GitFL implemented in Algorithm 1. Figure 6 presents the ablation study results on CIFAR-10 dataset with ResNet-18 following IID distribution. We can observe that “GitFL+CV” achieves the highest inference performance among all the four designs. Note that the improvement of “GitFL+C” over “GitFL+R” is negligible, since without the model staleness information the curiosity strategy itself cannot benefit FL training.

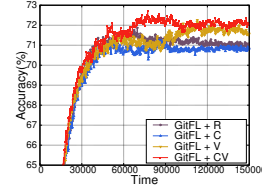

Fig. 6. Ablation study for RL-based client selection

V. CONCLUSION

Due to the notorious straggler issue, it is hard for existing FL methods to effectively control the discrepancies between the global model and delayed local models, resulting in low inference accuracy and long training convergence time. To address this problem, this paper introduced a novel asynchronous FL framework named GitFL, whose implementation is inspired by the famous version controller system Git. Unlike traditional FL methods, GitFL aggregates the master model based on both the pushed branch models and their version information. Meanwhile, by adopting our proposed RL-based device selection heuristic, GitFL supports adaptive load balance of versioned branch models on devices according to their staleness. Specifically, a pulled model with a newer version will be more likely to be assigned on a less frequently selected straggler. Comprehensive experimental results show that, compared with state-of-the-art asynchronous FL methods, GitFL can achieve better FL performance in terms of both training time and inference performance considering various uncertainties.

REFERENCES

- [1] X. Zhang, et al., “Efficient Federated Learning for Cloud-Based AIoT Applications”, *IEEE TCAD*, 41(11):2211-2223, 2021.
- [2] R. Chandrasekaran, et al., “FHDnn: Communication Efficient and Robust Federated Learning for AIoT Networks”, *DAC*, 37-42, 2022.
- [3] X. Lin, et al., “Lithography Hotspot Detection via Heterogeneous Federated Learning with Local Adaptation”, *ASP-DAC*, 166-171, 2022.
- [4] Y. Wu, et al., “Federated Contrastive Learning for Dermatological Disease Diagnosis via On-device Learning”, *ICCAD*, 1-7, 2021.
- [5] B. McMahan, et al., “Communication-efficient learning of deep networks from decentralized data”, *AISTATS*, 1273-1282, 2017.
- [6] C. Xie, et al., “Asynchronous federated optimization”, arXiv:1903.03934, 2019.
- [7] J. Cao, et al., “HADFL: Heterogeneity-aware Decentralized Federated Learning Framework”, *DAC*, 2021, pp. 1-6.
- [8] Z. Xu, et al., “Helios: Heterogeneity-Aware Federated Learning with Dynamically Balanced Collaboration”, *DAC*, 997-1002, 2021.
- [9] W. Wu, et al., “SAFA: A semi-asynchronous protocol for fast federated learning with low overhead.” *IEEE TC*, 70(5):655-668, 2020.
- [10] Q. Ma, et al., “FedSA: A semi-asynchronous federated learning mechanism in heterogeneous edge computing.” *IEEE JSAC*, 39(12):3654-3672, 2021.

- [11] P. Gupta, et al., "Underdesigned and Opportunistic Computing in Presence of Hardware Variability," *IEEE TCAD*, 32(1):8-23, 2013.
- [12] D. Pathak, et al., "Curiosity-driven exploration by self-supervised prediction" *ICML*, 2778-2787, 2017.
- [13] M. Bellemare, et al., "Unifying Count-Based Exploration and Intrinsic Motivation," *NeurIPS*, 1471-1479, 2016.
- [14] S. Caldas, et al., "Leaf: A benchmark for federated settings," arXiv:1812.01097, 2018.
- [15] Pytorch, "Models and pre-trained weight," <https://pytorch.org/vision/stable/models.html>, 2022.