

EXPRESSIVE-VC: HIGHLY EXPRESSIVE VOICE CONVERSION WITH ATTENTION FUSION OF BOTTLENECK AND PERTURBATION FEATURES

Ziqian Ning¹, Qicong Xie¹, Pengcheng Zhu², Zhichao Wang¹, Liumeng Xue¹, Jixun Yao¹,
Lei Xie^{1*}, Mengxiao Bi²

¹Audio, Speech and Language Processing Group (ASLP@NPU), School of Computer Science,
Northwestern Polytechnical University, Xi'an, China

²Fuxi AI Lab, NetEase Inc., Hangzhou, China

ABSTRACT

Voice conversion for highly expressive speech is challenging. Current approaches struggle with the balancing between speaker similarity, intelligibility and expressiveness. To address this problem, we propose *Expressive-VC*, a novel end-to-end voice conversion framework that leverages advantages from both neural bottleneck feature (BNF) approach and information perturbation approach. Specifically, we use a BNF encoder and a Perturbed-Wav encoder to form a content extractor to learn *linguistic* and *para-linguistic* features respectively, where BNFs come from a robust pre-trained ASR model and the perturbed wave becomes speaker-irrelevant after signal perturbation. We further fuse the linguistic and para-linguistic features through an attention mechanism, where speaker-dependent prosody features are adopted as the attention query, which result from a prosody encoder with target speaker embedding and normalized pitch and energy of source speech as input. Finally the decoder consumes the integrated features and the speaker-dependent prosody feature to generate the converted speech. Experiments demonstrate that Expressive-VC is superior to several state-of-the-art systems, achieving both high expressiveness captured from the source speech and high speaker similarity with the target speaker; meanwhile intelligibility is well maintained.

Index Terms— voice conversion, expressive, information perturbation, feature fusion

1. INTRODUCTION

The information conveyed in human speech can be roughly categorized into linguistic, para-linguistic and non-linguistic aspects, representing language, rhythmic-emotional and speaker identity respectively [1]. Moreover, non-verbal sounds, such as breathing, laughing and crying, are also essential in speech communication. Voice conversion (VC) is a technique that alters speaker-related information in a given speech to make it sound like another speaker while preserving the rest aspects of speech [2], ideally including linguistic, para-linguistic and even non-verbal aspects. It has been widely used in scenarios such as personalized speech synthesis [3] and privacy protection [4]. With the advances of deep learning, voice conversion has drawn much attention in more challenging scenarios such as movie dubbing with highly expressive speech contents.

In voice conversion, the essential task is to decouple the speaker-relevant and -irrelevant information from the source audio and transfer the aforementioned speaker-irrelevant information to the target speaker. This is not a trivial task as those components are highly entangled in speech.

Some disentanglement approaches rely on the fine-grained design of the voice conversion model itself, including adopting speaker-specific modules, losses, or learning algorithms in the voice conversion model to constrain the learned feature to represent either linguistic content or speaker identity. For example, vector quantization (VQ) [5–7], adaptive instance normalization [8] and gradient reversal layer (GRL) [9] are adopted to obtain relatively pure linguistic-related feature and remove speaker-related information in the learned feature [5–9]. Furthermore, mutual information (MI) loss can be adopted to minimize the correlation between the speaker and linguistic information in the learned feature [6, 10]. These approaches often face a dilemma in real applications – to maintain reasonable target speaker similarity, there has to be an empirical compensation on the transferred expressiveness; otherwise, the source speaker’s timbre may leak to the target speaker, making converted speech sound somehow like uttered by the source speaker or a mixture of both.

Some prior disentanglement actions can be conducted outside or before the voice conversion model. Taking the decoupled features as input, the VC model can make further disentanglement more easily. In this direction, Phonetic Posterior Grams (PPGs) and neural network bottleneck features (BNFs) are usually adopted to help the disentanglement. Specifically, BNFs are a set of activation of nodes over time from a neural network bottleneck layer, while PPGs are obtained by stacking a sequence of phonetic posterior probabilistic vectors from the neural network. Both BNFs and PPGs, usually obtained from a well-trained acoustic model in an automatic speech recognition (ASR) system, are proven to be linguistic-rich, speaker-independent and noise-robust. Thus using the PPGs/BNFs as intermediate representation, the voice conversion process is factorized as a speech-to-BNFs/PPGs module and a BNFs/PPGs-to-speech module, or the so-called recognition-synthesis framework [9, 11–13]. In this way, the linguistic information embedded in the source speech can be transferred stably to the target speech. As containing mostly the linguistic information in BNFs/PPGs, the converted speech apparently loses the expressiveness of the source speech to a large extent. The use of extra prosody features, such as pitch, can be a remedy to this problem [14–16].

Recently, information perturbation has been introduced to remove speaker timbre in prior for voice conversion [17]. The basic idea of information perturbation is to process all the unwanted information in the speech by signal processing beforehand which can make the neural network learn the essential information effectively. Specifically, information perturbation is adopted to remove speaker-related information in the source speech and thus the linguistic information is subsequently modeled by a content encoder [18]. Beyond the linguistic information, para-linguistic, e.g., emotional

* Corresponding author.

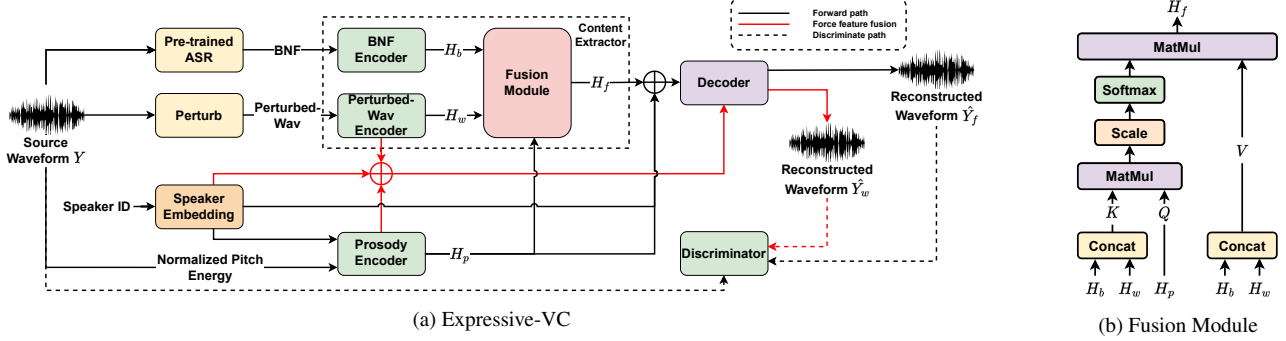

Fig. 1: The architecture of (a) Expressive-VC and (b) fusion module.

information, can also be preserved after speaker perturbation in the speech [19]. In this way, the voice model no longer suffers from the aforementioned trade-off between speaker similarity and expressiveness. Thus it is promising for information perturbation based method to transfer all the expressions in the source speech to the target speaker while maintaining good similarity with the target speaker. However, as the perturbation parameters are empirically selected, this kind of method may lack robustness in intelligibility and quality in the converted speech.

To achieve voice conversion for highly expressive source speech, in this paper, we propose *Expressive-VC*, a novel end-to-end voice conversion framework that leverages advantages from both neural bottleneck feature approach and information perturbation approach. Specifically, we use a BNF encoder and a Perturbed-Wav encoder to form a content extractor to learn *linguistic* and *para-linguistic* features respectively, where BNFs come from a robust pre-trained ASR model and the perturbed wave is considered to be speaker-irrelevant and after signal perturbation. We further fuse the linguistic and para-linguistic features through a scaled dot-product attention mechanism, where speaker-dependent prosody features are adopted as the attention query, which result from a prosody encoder with target speaker embedding and normalized pitch and energy of source speech as input. Finally the decoder consumes the fused feature and speaker-dependent prosody feature to generate the converted speech. Extensive experiments demonstrate that Expressive-VC is superior to several competitive systems, achieving both high expressiveness captured from the source speech and high speaker similarity with the target speaker; meanwhile intelligibility is well maintained.

2. PROPOSED APPROACH

To perform expressive voice conversion, we design our Expressive-VC system by fusing robust linguistic information embedded in the bottleneck feature (BNF) and rich para-linguistic information contained in the speaker-attribute-perturbed wave (Perturbed-wav). As shown in Fig. 1(a), Expressive-VC is based on an encoder-decoder architecture, mainly consisting of four components – content extractor, prosody encoder, decoder and discriminator.

2.1. Content Extractor

The content extractor is composed of a BNF encoder, a Perturbed-Wav encoder and a fusion module. The two encoders are designed to learn linguistic and para-linguistic features from source speech, respectively. Subsequently the fusion module fuses the two types of features for better expressivity and reasonable intelligibility in the converted speech.

BNF & Perturbed-Wav Encoders The BNF encoder takes BNFs as input and output linguistic embedding H_b for the source speech, and the Perturbed-Wav encoder takes the perturbed wave as input to generate para-linguistic-related embedding H_w of the

source speech. H_b and $H_w \in \mathbb{R}^{T \times F}$, where T represents the sequence length and F is the dimension of the embeddings. The BNFs are extracted from the source waveform Y by a pre-trained ASR model. The perturbed wave is the waveform perturbed by three signal processing functions: pitch randomization (pr), formant shifting (fs), and random frequency shaping using a parametric equalizer (peq). The pitch randomization function shifts the pitch and scales its range, and the formant shifting function also shifts the formants, which encourages to change the speaker timbre in the source waveform. By modifying the energy of different frequency bands, the parametric equalizer function further removes the speaker-relevant information. In summary, the speaker perturbation process on the source waveform Y can be simply described as

$$\text{Perturbed-wav} = pr(fs(peq(Y))), \quad (1)$$

where the perturbed wave is regarded as speaker irrelevant while the general linguistic and para-linguistic pattern are maintained.

Feature Fusion Module Obtaining robust and rich content representation including both linguistic and para-linguistic information from source speech is essential in VC tasks. As discussed earlier, BNFs are considered to be linguistic-rich but lose most of the expressivity in the speech. By contrast, the embedding extracted from the speaker-perturbed wave may contain rich expressive aspects of speech. An intuitive idea to combine both features by simple addition or concatenation. However, we believe that the fusion should be done dynamically because the contributions from linguistic and para-linguistic aspects vary through time. For example, non-verbal sounds such as breathing may have low contribution from the BNF embedding but high contribution from the Perturbed-wav embedding. Note that those non-verbal sounds are not explicitly modeled in an acoustic model of ASR.

To realize dynamic fusion, we propose an attention-based fusion module to effectively combine the linguistic feature H_b and para-linguistic feature H_w . As shown in Fig. 1 (b), the concatenation result of H_b and H_w is used as key $K \in \mathbb{R}^{T \times 2 \times F}$ and value $V \in \mathbb{R}^{T \times 2 \times F}$. The output of prosody encoder (described in Section 2.2) H_p is used as query $Q \in \mathbb{R}^{T \times F \times 1}$ to integrate the linguistic and para-linguistic information in H_b and H_w . In other words, we use the general prosody pattern of the source speech (source speaker timbre removed) to weight the fusion of the two branches. Following the attention mechanism in [20], we use the scaled dot-product operation as the similarity measure. The whole process of the proposed fusion module can be described as:

$$K = V = \text{concat}(H_b, H_w) \quad (2)$$

$$Q = H_p \quad (3)$$

$$\text{attention}(Q, K) = \text{softmax}\left(\frac{QK}{\sqrt{F}}\right), \quad (4)$$

$$H_f = \text{attention}(Q, K)V \quad (5)$$

Table 1: Comparison between Expressive-VC (with ablation), BNF-VC, Perturb-VC, and AGAIN-VC, in terms of speaker similarity MOS (SMOS) and naturalness MOS (NMOS) with confidence intervals of 95% under 3 voice conversion scenarios. Character Error Rate (CER) is also calculated for intelligibility measure. CER for source speech is 6.1% (non-expressive) and 10.3% (expressive).

	Non-expressive			Expressive			Non-verbal		Overall	
	NMOS \uparrow	SMOS \uparrow	CER \downarrow	NMOS \uparrow	SMOS \uparrow	CER \downarrow	NMOS \uparrow	SMOS \uparrow	NMOS \uparrow	SMOS \uparrow
BNF-VC	3.97 \pm 0.034	3.91\pm0.045	7.3	3.81 \pm 0.043	3.59 \pm 0.057	11.5	3.75 \pm 0.022	3.59 \pm 0.050	3.84 \pm 0.042	3.70 \pm 0.032
Perturb-VC	3.67 \pm 0.040	3.32 \pm 0.037	9.7	3.55 \pm 0.048	3.66 \pm 0.049	16.9	3.76 \pm 0.050	3.22 \pm 0.065	3.66 \pm 0.050	3.41 \pm 0.030
AGAIN-VC	2.81 \pm 0.037	3.16 \pm 0.048	14.1	2.80 \pm 0.034	2.96 \pm 0.028	22.2	2.66 \pm 0.041	2.77 \pm 0.029	2.76 \pm 0.036	2.96 \pm 0.046
Expressive-VC	4.00\pm0.049	3.81 \pm 0.035	8.7	4.05\pm0.042	3.78\pm0.032	11.8	4.06\pm0.041	3.83\pm0.035	4.04\pm0.034	3.81\pm0.040
-Fusion Module	3.57 \pm 0.050	3.62 \pm 0.034	9.2	3.68 \pm 0.048	3.59 \pm 0.028	14.9	3.90 \pm 0.032	3.61 \pm 0.028	3.71 \pm 0.042	3.61 \pm 0.043
$-\mathcal{L}_{G_c}, \mathcal{L}_{D_c}$	3.88 \pm 0.033	3.72 \pm 0.037	8.8	3.79 \pm 0.034	3.75 \pm 0.040	13.5	3.37 \pm 0.058	3.41 \pm 0.024	3.68 \pm 0.032	3.63 \pm 0.049
-Speed Aug	3.71 \pm 0.042	3.71 \pm 0.034	10.4	3.96 \pm 0.048	3.75 \pm 0.029	18.1	3.46 \pm 0.034	3.27 \pm 0.026	3.71 \pm 0.034	3.58 \pm 0.034

where $H_f \in \mathbb{R}^{T \times F}$ is the output of the fusion module.

2.2. Prosody Encoder

To better preserve the prosody in the source speech and obtain high speaker similarity with the target speech, inspired by [18], a prosody encoder is used to learn the speaker-related prosody representation. First, pitch (f_0) and energy (e) are extracted from the source speech Y and then z-score normalization is performed on pitch to remove the source speaker’s timbre, yielding a speaker-independent prosody. Then the conditional layer normalization (CLN) [21] is adopted to generate the target speaker-related prosody feature H_p by using the target speaker embedding as the conditional information:

$$H_p = \text{concat}\left(\gamma \frac{f_0 - \mu(f_0)}{\sigma(f_0)} + \beta, e\right) \quad (6)$$

where γ and β are scale and bias vectors about speaker embedding, while $\mu(f_0)$ and $\sigma(f_0)$ stand for utterance level mean and variance of f_0 respectively. H_p has two usages – one is used as the attention query in the aforementioned fusion module while another is fed to the decoder together with the content extractor output.

2.3. Decoder and Discriminator

With the input of source speech and target speaker identity, our proposed model directly reconstructs waveform without an explicit vocoder. Our decoder follows HiFi-GAN [22] using multiple discriminators for adversarial training, including multi-period discriminator (MPD), multi-scale discriminator (MSD), and multi-resolution spectrogram discriminator. We denote the three discriminators as D and the rest part of the proposed Expressive-VC model as generator G . The loss functions of G and D can be described as:

$$\mathcal{L}_G(Y, \hat{Y}) = \mathcal{L}_{adv_g}(Y, \hat{Y}) + \mathcal{L}_{fm}(Y, \hat{Y}) + \mathcal{L}_{stft}(Y, \hat{Y}), \quad (7)$$

$$\mathcal{L}_D(Y, \hat{Y}) = \mathcal{L}_{adv_d}(Y, \hat{Y}), \quad (8)$$

where Y and \hat{Y} are ground-truth and predicted waveform. \mathcal{L}_{adv_g} and \mathcal{L}_{adv_d} are the adversarial loss of the generator and discriminator respectively. Besides, the feature matching loss \mathcal{L}_{fm} [23] and the multi-resolution STFT loss \mathcal{L}_{stft} [24] are also adopted. As mentioned in Section 2.4, except predicting waveform \hat{Y}_f from fusion content H_f , H_w is also used to directly reconstruct waveform \hat{Y}_w . The overall objective function is described as

$$\mathcal{L}_{total_G}(Y, \hat{Y}_f, \hat{Y}_w) = \mathcal{L}_G(Y, \hat{Y}_f) + \mathcal{L}_G(Y, \hat{Y}_w), \quad (9)$$

$$\mathcal{L}_{total_D}(Y, \hat{Y}_f, \hat{Y}_w) = \mathcal{L}_{adv_d}(Y, \hat{Y}_f) + \mathcal{L}_{adv_d}(Y, \hat{Y}_w). \quad (10)$$

2.4. Training Strategy for Forcing Feature Fusion

Ideally, the fusion module should learn to obtain linguistic information from H_b while extracting para-linguistic information from H_w that H_b can not well represent. However, in practice, since BNFs are more related to linguistic information than the perturbed waveform, learning linguistic information from BNF encoder is much easier than that from the Perturbed-wav encoder. Consequently, the fusion module tends to only focus on the linguistic information H_b

extracted from BNFs, causing the failure of the fusion module and the Perturbed-wav encoder. To encourage better feature fusion, the convergence speed and content extraction ability of the Perturbed-wav encoder need to be particularly strengthened during training. As shown in the red arrow in Fig. 1(a), bypassing the fusion module, H_w and H_p are directly added and then fed into the decoder for waveform reconstruction. Through this auxiliary training, the Perturbed-wav encoder can be directly guided by waveform reconstruction and optimized faster. Finally with this training trick and the prosody encoder provided query, the fusion module can perform more reasonable fusion between H_b and H_w .

3. EXPERIMENTS

3.1. Experimental setup

In the experiments, all testing VC models are trained on an internal Mandarin corpus, containing about 100K neutral utterances and 60K expressive utterances uttered by 230 speakers. One male and one female speakers are reserved as the target speakers for voice conversion tests. A set of 30 speech recordings, including typical reading (non-expressive), expressive and non-verbal clips, are used as source data, 10 utterances for each category. The selected recordings are converted to the two target speakers using the proposed model and all the comparison models to further perform evaluations. All the speech utterances are resampled to 24 kHz. For perturbation methods, we conducted formant shifting, pitch randomization, and random frequency shaping to the waveform with the same perturbation coefficient as NANSY [17]. Besides, speed augmentation is adopted to enrich prosody diversity [12], using a random multiplier of 1.1-1.5. During training, augmented and original waveforms are fed to the VC model alternatively. Mel spectrum, pitch, and energy are computed with 50ms frame length and 10ms hop size. The ASR system for BNF extraction is a conformer-based model trained on a Mandarin ASR corpus Wenetspeech [25], implemented by WeNet toolkit [26]. In our implementation, the BNF encoder consists of two convolution layers, each followed by layer normalization. The Perturbed-wav encoder consists of convolution layers with four strides, downsampled by a factor of 6, 5, 5, and 2, each of which is also followed by a layer normalization. The architecture and hyper-parameters of the prosody encoder, decoder, and discriminator follow the origin configuration in [18].

To validate the performance of the proposed model in highly expressive voice conversion, **BNF-VC** [15], **Perturb-VC** [18], and **AGAIN-VC** [8] are used as our comparison systems, all implemented using the same training data described above. BNF-VC, based on the BNF framework and helped with explicit prosody modeling, is a good representative of balancing intelligibility, expressiveness and speaker similarity. Perturb-VC is a newly perturbation based end-to-end model while AGAIN-VC is another popular approach that has open-source code.¹

¹<https://github.com/KimyAnly/AGAIN-VC>

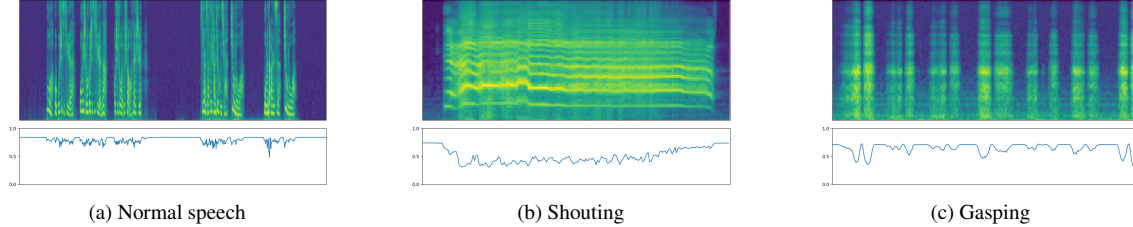

Fig. 2: Spectrograms (the first row) of normal speech, shouting and gasping with their corresponding BNF weight trajectory (the second row).

Table 2: Pearson correlation in energy and lf0.

	Expressive-VC	BNF-VC [15]	Perturb-VC [18]	AGAIN-VC [8]
LF0 \uparrow	0.754	0.741	0.625	0.368
Energy \uparrow	0.985	0.977	0.982	0.903

3.2. Subjective Evaluation

We conduct Mean Opinion Score (MOS) tests to evaluate the naturalness and speaker similarity of different models. Since this paper aims to perform highly expressive voice conversion, the naturalness metric considers the consistency between source speech and converted speech in terms of expressiveness and pronunciation. Higher naturalness MOS score means converted speech can better maintain the expressiveness of the source speech. In both MOS tests, there are 20 listeners participated. Particularly for speaker similarity test, we use target speaker’s real recording as reference. We recommend the readers listen to our samples².

Speech Naturalness Evaluation The results shown in Table 1 indicate that our proposed Expressive-VC can achieve the best performance in speech naturalness. Specifically, in the non-expressive scenario, BNF-VC gets a similar score to Expressive-VC, which shows that BNF can well represent content information of speech in this scenario. For expressive validation, all comparison systems show performance degradation. Expressive-VC gets a higher MOS score which shows that Expressive-VC can capture more rich content with para-linguistic information. Particularly for non-verbal cases, Expressive-VC has obvious superiority in naturalness and the MOS score remains at the same level with expressive and non-expressive cases.

Speaker Similarity Evaluation The results of MOS tests in terms of speaker similarity for different models are also shown in Table 1, in which higher MOS means better performance. In the non-expressive scenario, BNF-VC achieves higher speaker similarity than other systems. We also notice that speaker similarity still remains at a high level for non-verbal cases for Expressive-VC. In expressive and non-verbal scenarios, compared with BNF-VC, Perturb-VC, and AGAIN-VC, the proposed method achieves better performance in speaker similarity. Considering the overall performance of speaker similarity and the superiority of the proposed method in the naturalness, Expressive-VC shows better performance in the highly expressive voice conversion.

Ablation Study To investigate the importance of our proposed methods in Expressive-VC, three ablation systems were obtained by dropping the fusion module, auxiliary training loss ($\mathcal{L}_{G_c}, \mathcal{L}_{D_c}$), and speed augmentation, referred to as *-Fusion Module*, *- $\mathcal{L}_{G_c}, \mathcal{L}_{D_c}$* , and *-Speed Aug*. Note that when dropping the fusion module, the fusion of features is performed by direct concatenation. As shown in Table 1, dropping these methods brings obvious performance degradation in terms of speech naturalness and speaker similarity. Specifically, without the fusion module, the concatenation of two features cannot be dynamically adjusted, leading to performance degradation. Besides, when \mathcal{L}_{G_c} and \mathcal{L}_{D_c} are discarded, the process

of feature fusion fails, and the performance drops in both naturalness and speaker similarity. As can be seen, speech speed augmentation also contributes to the proposed system’s performance.

3.3. Objective Analysis

Character Error Rate We use the same pre-trained ASR model for BNF extraction to recognize the source speech, converted non-expressive and expressive speech clips. The character error rate is also reported in Table 1. We can see that AGAIN-VC obtains the highest CER, indicating bad intelligibility. By contrast, our Expressive-VC has similar CER with BNF-VC, while both systems induce small CER increase as compared with the source speech. We also notice that the CER is much higher for expressive clips as compared with non-expressive counterparts. We believe expressive speech is more difficult to recognize by a regular ASR system. In summary, the proposed system still can maintain reasonable intelligibility.

Visualization on Fusion Process To further study the process of feature fusion, as shown in Fig. 2, three speech recordings containing normal speech, shouting, and gasping are used as source speech to obtain the mel spectrums and attention weights. Note that the weight curves vary from 0 to 1, indicating the proportion of H_b in the fusion feature. As can be seen, compared with the weight curve of normal speech in Fig. 2(a), the weight curves of Fig. 2(b) and Fig. 2(c) are much lower when shouting and gasping happen, indicating that the H_w extracted from the perturbed waveform is more involved in the fusion process. Moreover, the shouting in Fig. 2(b) gradually weakens over time, corresponding to a gradual increase in the weight of H_b , demonstrating that the model can flexibly adjust the proportion of H_b and H_w in the fusion feature according to the expression and pronunciation in different times. These suggest that the two features are fused as we expected: H_b from BNFs mainly contains linguistic formation, and the H_w from perturbed waveform provides additional para-linguistic information.

Pitch Correlation To further verify the expressiveness of each system, we calculate the Pearson correlation coefficients of energy and pitch between source and converted speech of all systems. The higher the Pearson correlation coefficient of the model, the higher the accuracy of the predicted prosodic attributes. Table 2 shows that the proposed system has the highest lf0 and energy correlations. It illustrates that the proposed system can better maintain the expressive aspects of the source speech compared to the comparison systems.

4. CONCLUSIONS

In this paper, we propose Expressive-VC for highly expressive voice conversion. This task is challenging due to the difficulty of maintaining both the linguistic and para-linguistic information in the source speech while achieving high-quality voice conversion with target speaker’s timbre. To this end, multiple feature fusion is proposed in a specifically designed network structure, leveraging the advances from both bottleneck feature approach and the signal perturbation approach. Extensive experiments show that Expressive-VC achieves superior performance in highly expressive voice conversion tasks, including non-verbal sound conversion.

²Demo: <https://nzqian.github.io/Expressive-VC.github.io/>

5. REFERENCES

- [1] Yoichi Yamashita, “A review of paralinguistic information processing for natural speech communication,” *Acoustical Science and Technology*, vol. 34, no. 2, pp. 73–79, 2013.
- [2] Berrak Sisman, Junichi Yamagishi, Simon King, and Haizhou Li, “An overview of voice conversion and its challenges: From statistical modeling to deep learning,” *IEEE ACM Trans. Audio Speech Lang. Process.*, vol. 29, pp. 132–157, 2021.
- [3] Kaizhi Qian, Yang Zhang, Shiyu Chang, Xuesong Yang, and Mark Hasegawa-Johnson, “Autovc: Zero-shot voice style transfer with only autoencoder loss,” in *Proc. ICML*. 2019, vol. 97 of *Proceedings of Machine Learning Research*, pp. 5210–5219, PMLR.
- [4] Natalia A. Tomashenko, Xin Wang, Emmanuel Vincent, Jose Patino, Brij Mohan Lal Srivastava, Paul-Gauthier Noé, Andreas Nautsch, Nicholas W. D. Evans, Junichi Yamagishi, Benjamin O’Brien, Anaïs Chanclu, Jean-François Bonastre, Massimiliano Todisco, and Mohamed Maouche, “The voiceprivacy 2020 challenge: Results and findings,” *Comput. Speech Lang.*, vol. 74, pp. 101362, 2022.
- [5] Wen-Chin Huang, Hao Luo, Hsin-Te Hwang, Chen-Chou Lo, Yu-Huai Peng, Yu Tsao, and Hsin-Min Wang, “Unsupervised representation disentanglement using cross domain features and adversarial learning in variational autoencoder based voice conversion,” *IEEE Trans. Emerg. Top. Comput. Intell.*, vol. 4, no. 4, pp. 468–479, 2020.
- [6] Disong Wang, Liqun Deng, Yu Ting Yeung, Xiao Chen, Xunying Liu, and Helen Meng, “VQMIVC: vector quantization and mutual information-based unsupervised speech representation disentanglement for one-shot voice conversion,” in *Proc. INTERSPEECH*. 2021, pp. 1344–1348, ISCA.
- [7] Shaojin Ding and Ricardo Gutierrez-Osuna, “Group latent embedding for vector quantized variational autoencoder in non-parallel voice conversion,” in *Proc. INTERSPEECH*, Gernot Kubin and Zdravko Kacic, Eds. 2019, pp. 724–728, ISCA.
- [8] Yen-Hao Chen, Da-Yi Wu, Tsung-Han Wu, and Hung-yi Lee, “Again-vc: A one-shot voice conversion using activation guidance and adaptive instance normalization,” in *Proc. ICASSP*. 2021, pp. 5954–5958, IEEE.
- [9] Zhonghao Li, Benlai Tang, Xiang Yin, Yuan Wan, Ling Xu, Chen Shen, and Zejun Ma, “Ppg-based singing voice conversion with adversarial representation learning,” in *Proc. ICASSP*. 2021, pp. 7073–7077, IEEE.
- [10] Sicheng Yang, Methawee Tantrawenith, Haolin Zhuang, Zhiyong Wu, Aolan Sun, Jianzong Wang, Ning Cheng, Huaizhen Tang, Xintao Zhao, Jie Wang, and Helen Meng, “Speech representation disentanglement with adversarial mutual information learning for one-shot voice conversion,” in *Proc. INTERSPEECH*. 2022, pp. 2553–2557, ISCA.
- [11] Lifa Sun, Kun Li, Hao Wang, Shiyin Kang, and Helen M. Meng, “Phonetic posteriorgrams for many-to-one voice conversion without parallel data training,” in *IEEE International Conference on Multimedia and Expo, ICME 2016, Seattle, WA, USA, July 11-15, 2016*. 2016, pp. 1–6, IEEE Computer Society.
- [12] Xintao Zhao, Feng Liu, Changhe Song, Zhiyong Wu, Shiyin Kang, Deyi Tuo, and Helen Meng, “Disentangling content and fine-grained prosody information via hybrid ASR bottleneck features for voice conversion,” in *Proc. ICASSP*. 2022, pp. 7022–7026, IEEE.
- [13] Xiaohai Tian, Eng Siong Chng, and Haizhou Li, “A speaker-dependent wavenet for voice conversion with non-parallel data,” in *Proc. INTERSPEECH*. 2019, pp. 201–205, ISCA.
- [14] Songxiang Liu, Yuewen Cao, Shiyin Kang, Na Hu, Xunying Liu, Dan Su, Dong Yu, and Helen Meng, “Transferring source style in non-parallel voice conversion,” in *Proc. INTERSPEECH*. 2020, pp. 4721–4725, ISCA.
- [15] Zhichao Wang, Xinyong Zhou, Fengyu Yang, Tao Li, Hongqiang Du, Lei Xie, Wendong Gan, Haitao Chen, and Hai Li, “Enriching source style transfer in recognition-synthesis based non-parallel voice conversion,” in *Proc. INTERSPEECH*.
- [16] Zheng Lian, Rongxiu Zhong, Zhengqi Wen, Bin Liu, and Jianhua Tao, “Towards fine-grained prosody control for voice conversion,” in *Proc. ISCSLP*. 2021, pp. 1–5, IEEE.
- [17] Hyeong-Seok Choi, Juheon Lee, Wansoo Kim, Jie Lee, Hoon Heo, and Kyogu Lee, “Neural analysis and synthesis: Reconstructing speech from self-supervised representations,” in *Proc. NIPS*, 2021, pp. 16251–16265.
- [18] Qicong Xie, Shan Yang, Yi Lei, Lei Xie, and Dan Su, “End-to-end voice conversion with information perturbation,” *CoRR*, vol. abs/2206.07569, 2022.
- [19] Yi Lei, Shan Yang, Xinfu Zhu, Lei Xie, and Dan Su, “Cross-speaker emotion transfer through information perturbation in emotional speech synthesis,” *IEEE Signal Process. Lett.*, vol. 29, pp. 1948–1952, 2022.
- [20] Ashish Vaswani, Noam Shazeer, Niki Parmar, Jakob Uszkoreit, Llion Jones, Aidan N. Gomez, Lukasz Kaiser, and Illia Polosukhin, “Attention is all you need,” in *Proc. NIPS*, 2017, pp. 5998–6008.
- [21] Mingjian Chen, Xu Tan, Bohan Li, Yanqing Liu, Tao Qin, Sheng Zhao, and Tie-Yan Liu, “Adaspeech: Adaptive text to speech for custom voice,” in *9th International Conference on Learning Representations, ICLR 2021, Virtual Event, Austria, May 3-7, 2021*. 2021, OpenReview.net.
- [22] Jungil Kong, Jaehyeon Kim, and Jaekyoung Bae, “Hifi-gan: Generative adversarial networks for efficient and high fidelity speech synthesis,” in *Proc. NIPS*, 2020.
- [23] Tim Salimans, Ian J. Goodfellow, Wojciech Zaremba, Vicki Cheung, Alec Radford, and Xi Chen, “Improved techniques for training gans,” in *Proc. NIPS*, 2016, pp. 2226–2234.
- [24] Shinji Takaki, Toru Nakashika, Xin Wang, and Junichi Yamagishi, “STFT spectral loss for training a neural speech waveform model,” in *Proc. ICASSP*. 2019, pp. 7065–7069, IEEE.
- [25] Binbin Zhang, Hang Lv, Pengcheng Guo, Qijie Shao, Chao Yang, Lei Xie, Xin Xu, Hui Bu, Xiaoyu Chen, Chenchen Zeng, Di Wu, and Zhendong Peng, “WENETSPEECH: A 10000+ hours multi-domain mandarin corpus for speech recognition,” in *Proc. ICASSP*. 2022, pp. 6182–6186, IEEE.
- [26] Zhuoyuan Yao, Di Wu, Xiong Wang, Binbin Zhang, Fan Yu, Chao Yang, Zhendong Peng, Xiaoyu Chen, Lei Xie, and Xin Lei, “Wenet: Production oriented streaming and non-streaming end-to-end speech recognition toolkit,” in *Proc. INTERSPEECH*. 2021, pp. 4054–4058, ISCA.