

# Multi-Speaker Multi-Style Speech Synthesis with Timbre and Style Disentanglement<sup>\*</sup>

Wei Song, Yanghao Yue, Ya-jie Zhang, Zhengchen Zhang, Youzheng Wu, and Xiaodong He

JD Technology Group  
{songwei11,yueyanghao,zhangyajie23,zhangzhengchen1,  
wuyouzheng1,hexiaodong}@jd.com

**Abstract.** Disentanglement of a speaker’s timbre and style is very important for style transfer in multi-speaker multi-style text-to-speech (TTS) scenarios. With the disentanglement of timbres and styles, TTS systems could synthesize expressive speech for a given speaker with any style which has been seen in the training corpus. However, there are still some shortcomings with the current research on timbre and style disentanglement. The current method either requires single-speaker multi-style recordings, which are difficult and expensive to collect, or uses a complex network and complicated training method, which is difficult to reproduce and control the style transfer behavior. To improve the disentanglement effectiveness of timbres and styles, and to remove the reliance on single-speaker multi-style corpus, a simple but effective timbre and style disentanglement method is proposed in this paper. The FastSpeech2 network is employed as the backbone network, with explicit duration, pitch, and energy trajectory to represent the style. Each speaker’s data is considered as a separate and isolated style, then a speaker embedding and a style embedding are added to the FastSpeech2 network to learn disentangled representations. Utterance level pitch and energy normalization are utilized to improve the decoupling effect. Experimental results demonstrate that the proposed model could synthesize speech with any style seen during training with high style similarity while maintaining very high speaker similarity.

**Keywords:** Speech Synthesis · Style Transfer · Disentanglement.

## 1 Introduction

With the development of deep learning technology in the last decade, speech synthesis technology has evolved from traditional statistics-based speech synthesis [1] to end-to-end based [2,3,4,5,6] and made great advancements. The current speech synthesis technology has been able to synthesize speech with high naturalness and high fidelity, and even some research [7] has been able to synthesize speech that human beings cannot distinguish between true recordings.

---

<sup>\*</sup> This work was supported by the National Key R&D Program of China under Grant No. 2020AAA0108600.

Although the great achievement in speech synthesis, there still exists a large improvement room for expressive speech synthesis, especially for multi-speaker multi-style Text to Speech (TTS) with cross-speaker style transfer [8,9,10]. Synthesizing speech with a target speaker’s timbre and other speaker’s style could further increase the application scenarios and expressiveness of the TTS system.

In order to synthesize more expressive speech, some researches [11,8,10] do style decoupling by using a single-speaker multi-style recording data to learn the style representation. However, it is difficult and expensive to collect these kinds of data in lots of scenarios. Some other works [12,9] try to remove this data restriction by learning a decoupled style representation, but most of them use complex network structure or rely on complicated training method, which makes it difficult to re-produce the experimental results or infeasible to control the network performance during inference.

A jointly trained reference encoder is used to learn implicit style representation in [12,13]. After the model is trained, audio with a different style or even from a different speaker could be taken as the reference audio to synthesize speech with the desired style while keeping the timbre unchanged. However, the reference-based method is unstable which usually generates unexpected style, and it’s non-trivial to choose the reference audio.

Pan *et al.* [8] use prosody bottle-neck feature to learn a compact style representation, and paper [10] uses a separate style encoder and speaker encoder to disentangle the speaker’s timbre and style, and cycle consistent loss is used to improve the disentanglement effect, a complex neural network and complicated training objectives are required to achieve good performance. Both [10] and [8] require single-speaker multi-style corpus to learning the disentanglement, which restricts the flexibility of their proposed models.

In this paper, we propose a simple but effective expressive speech synthesis network that disentangles speakers’ timbres and styles, which makes it available to do multi-speaker multi-style speech synthesis. The proposed system does not require a multi-speaker multi-style corpus, each speaker’s data is considered as an isolated style. The proposed network is similar to work [9], but we use FastSpeech2 [4] as the network backbone, which removes the skip/repeat pronunciation issue caused by the attention mechanism. Prosody features (duration, pitch, and energy) are used directly to improve the disentanglement effectiveness of timbre and style, furthermore, utterance level pitch and energy normalization (UttNorm) are used to prevent identity leakage from prosody features.

## 2 The Proposed Model

The proposed network utilizes FastSpeech2 [4] as the network backbone and applies utterance level pitch and energy normalization to achieve a better decoupling effect. MelGAN [14] is used as the neural vocoder to convert acoustic features to speech.

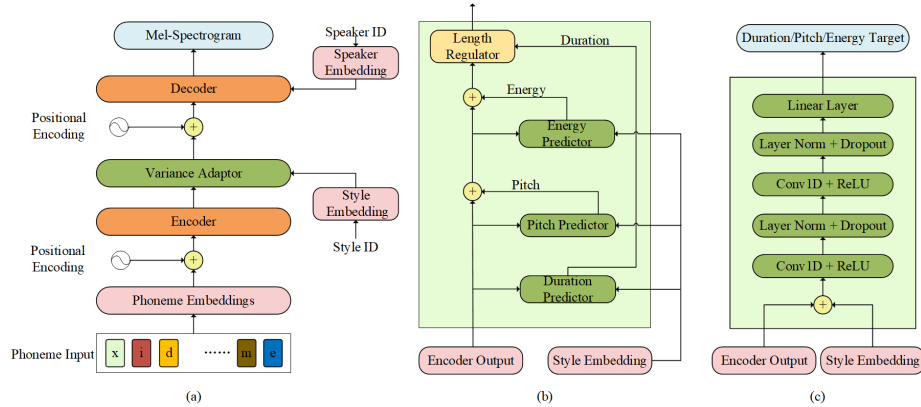

**Fig. 1.** An illustration of the proposed network architecture. (a) Network structure of the acoustic model. (b) The variance adaptor structure with style embedding as conditional input. (c) The structure of variance predictor.

## 2.1 The Network Structure Of Proposed Network

FastSpeech2 [4] network architecture is used as the network backbone for the proposed model, which consists of a phoneme encoder to learn syntactic and semantic features, a mel-spectrogram [3] decoder to generate frame-level acoustic features, and a variance adaptor to learn style-related features. The network structure is shown in Fig. 1 (a).

A style embedding is introduced to the network to learn a style-dependent variance adaptor, the network structure of variance adaptor is illustrated in Fig. 1 (b) and Fig. 1 (c). To decouple timbre and style, the speaker embedding is moved to the input of the decoder to make the decoder timbre dependent.

One important purpose of the proposed model is to remove the dependency of the single-speaker multi-style corpus, so each speaker’s corpus is considered as a unique style and we could learn style representation from other speakers’ corpus. Actually, during the training procedure, the speaker id and style id is identical, then it is very important to prevent style embedding from leaking into the backbone network, which means style embedding should only be used for style feature prediction and never be exposed to the backbone network. So in this proposed network, style embedding is only used in the variance adaptor to ensure that the whole network learns the speaker’s timbre by speaker embedding instead of style embedding, and style is only affected by style embedding.

## 2.2 Utterance Level Feature Normalization

The speaking style is represented in many aspects, such as the duration of each syllable, the fundamental frequency (F0), and the trajectory of pitch and energy. However, these scalars could still contain speaker identity and impact the decoupling effect. For example, female speakers usually have higher F0 [15] than

**Table 1.** The description of the dataset used in the experiment. There are three open-sourced corpus (with a \* in the speaker name) and three internal corpora.

Speaker	#Utterance	Style	Gender
CSMSC*	10000	normal	female
Originbeat-S1*	5000	normal	female
Originbeat-S2*	5000	normal	male
C1	10000	children story	female
F1	450	news-broadcasting	female
M1	35000	story-telling	male

male speakers, and excited speakers express higher energy value, so the pitch and energy features contain speaker timbre information to some extent, then it’s essential to normalize the style features to disentangle a speaker’s timbre and style.

In this paper, instead of speaker level normalization (SpkNorm), utterance level pitch and energy normalization (UttNorm) are used to remove speaker identity from the style features for better timbre and style disentanglement. The style difference in each utterance will lead to a statistics difference between speaker level and utterance level statistics, this difference could cause identity leakage and affect the decoupling effect, especially for the unprofessional, noisy recordings. UttNorm could eliminate this statistic difference and improve the timbre and style disentanglement effectiveness.

### 3 Experimental Setup

Three open-sourced Chinese mandarin corpora and three internal Chinese mandarin corpora with distinctive styles are used to train the proposed model. The open-sourced corpus includes CSMSC <sup>1</sup>, which is recorded by a female speaker, and the MST-Originbeat <sup>2</sup> [16], which consists of recordings from a female speaker and a male speaker. Details of the training data are listed in table 1.

The training data waves are converted to 16kHz, 16bit depth, and then scaled to 6dB in our experiments. The extracted phoneme labels and processed speech waves are aligned by the MFA [17] tool to detect the phoneme boundary. The 80-band mel-scale spectrogram is extracted as the training target with a 12ms hop size and 48ms window size. Pitch is extracted by using the PyWORLD <sup>3</sup> toolkit. Both pitch and energy trajectories are normalized in utterance level to remove speaker identity.

The proposed model is trained by Adam [18] optimizer with a batch size of 32 and noam [19] learning rate schedule. The learning rate is warmed up to a maximum value of 1e-3 in the first 4000 steps and then exponentially decayed. The model is trained by 400,000 steps and the network is regularized by weight decay with a weight of 1e-6.

<sup>1</sup> [https://www.data-baker.com/open\\_source.html](https://www.data-baker.com/open_source.html)

<sup>2</sup> <http://challenge.ai.iqiyi.com/detail?raceId=5fb2688224954e0b48431fe0>

<sup>3</sup> <https://github.com/JeremyCCHsu/Python-Wrapper-for-World-Vocoder>

**Table 2.** The 5 points MOS results with a confidence interval of 95%. 5 means the style or the timbre is exactly the same as the reference, and 1 means totally different.

Speaker	Speaker Similarity			Style Similarity		
	C1	F1	M1	C1	F1	M1
CSMSC	4.50±0.05	4.47±0.06	4.49±0.04	4.31±0.03	4.62±0.03	4.11±0.06
Originbeat-S1	4.36±0.08	4.66±0.02	4.29±0.06	4.13±0.03	4.18±0.05	4.08±0.08
Originbeat-S2	4.36±0.07	4.59±0.04	4.23±0.07	4.23±0.04	4.30±0.03	4.10±0.08

## 4 Experimental Results

This chapter shows the experimental results of the proposed timbre and style disentanglement network. We encourage the readers to listen to the synthesized speeches on our demo page <sup>4</sup>.

### 4.1 Subjective Evaluation

To evaluate the proposed method, Mean Opinion Score (MOS) evaluation is conducted to evaluate the speaker similarity and style similarity for the synthesized speech of different speakers and different styles. The target speakers are from the 3 open-sourced corpora, and our internal news-broadcasting (F1), children story (C1), and story-telling (M1) styles are used as the target style. Twenty utterances are synthesized for each speaker and style combination, listened to by 15 testers. During each MOS evaluation, the speaker similarity or style similarity is the only point that testers need to focus on.

MOS results of speaker similarity and style similarity are shown in Table 2, we could see that for a given target speaker, the speaker similarity of speeches in different style are very high and consistent, and the style similarity is also very high with the target style, which indicates that the proposed model achieves excellent disentanglement effect for speaker’s timbre and style.

### 4.2 Ablation Study Of Utterance Level Feature Normalization

To verify the effectiveness of UttNorm, another female corpus(112 sentences) crawled from a podcast, even with some background noise is chosen to demonstrate the impact.

In our experiments, due to the large variety of this noisy corpus from the oral podcast, a speaker similarity MOS evaluation and a preference evaluation are conducted to evaluate the performance of different normalization methods. We use speaker F1 as the target speaker and the style from this noisy corpus as the target style, then 20 sentences in the podcast domain are synthesized and listened to by 15 testers.

According to the MOS results for speaker similarity, when UttNorm is used, the speaker similarity increases from  $3.82\pm 0.05$ (SpkNorm) to  $3.91\pm 0.06$ (UttNorm),

<sup>4</sup> <https://weixsong.github.io/demos/MultiSpeakerMultiStyle/>

which showed that UttNorm could facilitate the decoupling effect of timbre and style for data with high variance, especially found data, noisy data or podcast data.

From the AB preference evaluation results, the proportions of preference are 0.17(SpkNorm), 0.35(No Preference), 0.48(UttNorm), and the  $p$ -value is less than 0.001. It could be found that the listeners strongly prefer the results from UttNorm, which proves the effectiveness of utterance normalization.

### 4.3 Demonstration Of The Proposed Model

Synthesized speeches with a given speaker and different styles are shown in Fig. 2 (a), and speeches for a given style and different speakers are shown in Fig. 2 (b). The fundamental frequency is consistent for the three different styles in Fig. 2 (a), and all the speakers’ pitch trajectories follow basically the same curve but with different fundamental frequency in Fig. 2 (b), this explains the decoupling effectiveness to some extent.

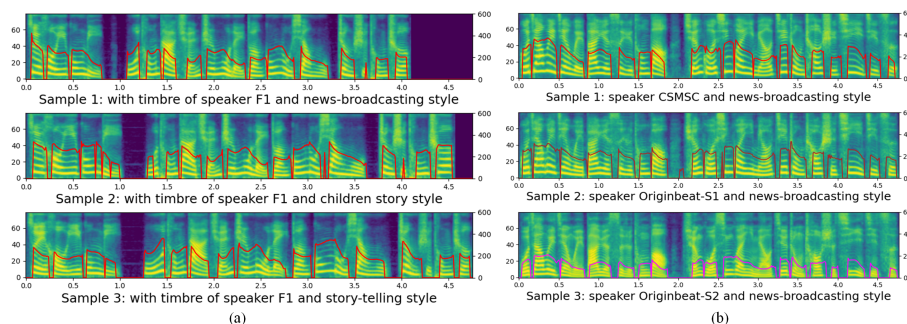
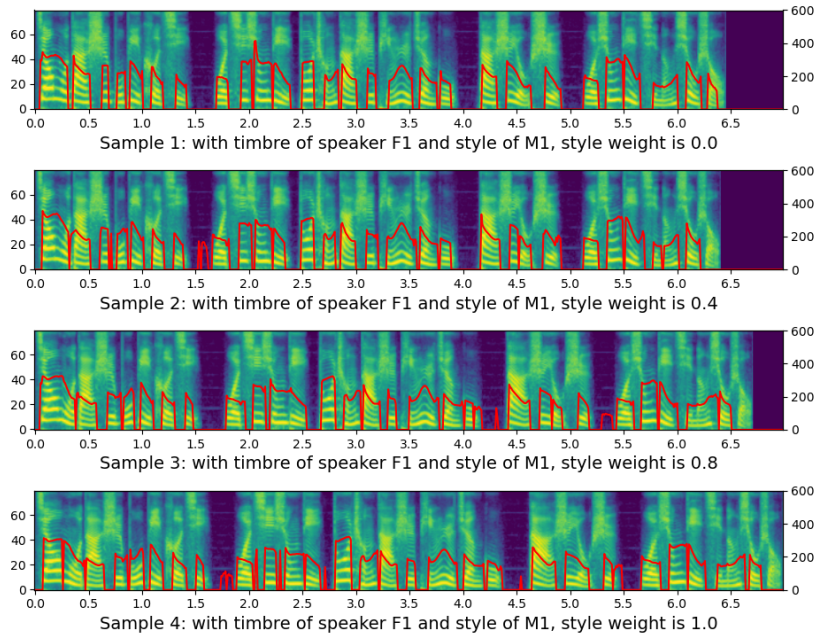

**Fig. 2.** A mel-spectrogram illustration of the proposed multi-speaker multi-style TTS model. (a) Speaker F1 is selected as the target speaker, the target style is the original news-broadcasting style, children story style, and story-telling style. (b) News-broadcasting style is selected as target style, the speakers are CSMSC, Originbeat-S1, and Originbeat-S2 respectively, from top to bottom.

### 4.4 Style Transition Illustration

As both a speaker ID and a style ID should be sent to the network to synthesize the target speaker’s speech with a given style, we could also use the speaker ID to generate a style embedding that represents the source style, and the embedding from the style ID represents the target style. By combining the style embeddings from source and target with different weights, we could generate speech with different target style intensities.

To demonstrate the continuity of the learned style embedding representation, a style transition example is given in Fig. 3. From the pitch trajectory in each synthesized speech we could find that the fundamental frequency is identical for



**Fig. 3.** A style transition illustration. Speaker F1 is selected as the target speaker and style M1 is selected as the target style, this figure shows the gradual style transition from style F1 to style M1 from top to bottom, with different target style weights.

different target style weight, indicating that the proposed model keep the timbre unchanged when synthesizing different style speech and achieves outstanding timbre and style disentanglement effect.

## 5 Conclusions

A simple but effective speaker’s timbre and style disentanglement network is proposed in this paper, which eliminates the reliance on a single-speaker multi-style corpus. The proposed network learns a style-dependent variance adaptor and a speaker-dependent mel-spectrogram prediction decoder. The style-related features are predicted by the variance adaptor with the guidance of style embedding, while the timbre is learned by the mel-spectrogram decoder with the control of speaker embedding. Utterance level feature normalization is proposed to prevent speaker information leakage from the style feature. Experimental results showed that the proposed model achieves good timbre and style disentanglement effect, for a given speaker the proposed model could synthesize speech with any style seen during training, even when the target style corpus only contains a few hundred training utterances. Furthermore, the proposed model learns a continuous style representation, which could generate speech that gradually transits from source style to target style.



## References

1. P. Taylor, *Text-to-speech synthesis*. Cambridge university press, 2009.
2. J. Sotelo, S. Mehri, K. Kumar, J. F. Santos, K. Kastner, A. Courville, and Y. Bengio, “Char2Wav: End-to-end speech synthesis,” in *Proc. ICLR*, Toulon, 2017.
3. Y. Wang, R. Skerry-Ryan, D. Stanton, Y. Wu, R. J. Weiss, N. Jaitly, Z. Yang, Y. Xiao, Z. Chen, S. Bengio, L. Quoc, and C. R. S. R. Agiomyrgiannakis, Yannis, “Tacotron: Towards end-to-end speech synthesis,” in *Proc. Interspeech*, Stockholm, 2017.
4. Y. Ren, C. Hu, T. Qin, S. Zhao, Z. Zhao, and T.-Y. Liu, “FastSpeech 2: Fast and High-Quality End-to-End Text to Speech,” *arXiv preprint arXiv:2006.04558*, 2020.
5. W. Ping, K. Peng, A. Gibiansky, S. O. Arik, A. Kannan, S. Narang, J. Raiman, and J. Miller, “Deep voice 3: Scaling text-to-speech with convolutional sequence learning,” in *arXiv:1710.07654*, 2017.
6. X. Tan, T. Qin, F. Soong, and T.-Y. Liu, “A Survey on Neural Speech Synthesis,” *arXiv preprint arXiv:2106.15561*, 2021.
7. X. Tan, J. Chen, H. Liu, J. Cong, C. Zhang, Y. Liu, X. Wang, Y. Leng, Y. Yi, L. He *et al.*, “NaturalSpeech: End-to-End Text to Speech Synthesis with Human-Level Quality,” *arXiv preprint arXiv:2205.04421*, 2022.
8. S. Pan and L. He, “Cross-speaker style transfer with prosody bottleneck in neural speech synthesis,” *arXiv preprint arXiv:2107.12562*, 2021.
9. Q. Xie, T. Li, X. Wang, Z. Wang, L. Xie, G. Yu, and G. Wan, “Multi-speaker multi-style text-to-speech synthesis with single-speaker single-style training data scenarios,” *arXiv preprint arXiv:2112.12743*, 2021.
10. X. An, F. K. Soong, and L. Xie, “Disentangling style and speaker attributes for tts style transfer,” *IEEE/ACM TASLP*, vol. 30, pp. 646–658, 2022.
11. T. Li, S. Yang, L. Xue, and L. Xie, “Controllable emotion transfer for end-to-end speech synthesis,” in *Proc. ISCSLP 2021*. IEEE, 2021, pp. 1–5.
12. Y. Wang, D. Stanton, Y. Zhang, R.-S. Ryan, E. Battenberg, J. Shor, Y. Xiao, Y. Jia, F. Ren, and R. A. Saurous, “Style tokens: Unsupervised style modeling, control and transfer in end-to-end speech synthesis,” in *International Conference on Machine Learning*. PMLR, 2018, pp. 5180–5189.
13. Y.-J. Zhang, S. Pan, L. He, and Z.-H. Ling, “Learning latent representations for style control and transfer in end-to-end speech synthesis,” in *Proc. ICASSP*. IEEE, 2019, pp. 6945–6949.
14. K. Kumar, R. Kumar, T. de Boissiere, L. Gestin, W. Z. Teoh, J. Sotelo, A. de Brébisson, Y. Bengio, and A. C. Courville, “MelGAN: Generative adversarial networks for conditional waveform synthesis,” in *Proc. NIPS*, Vancouver, 2019.
15. H. Zen, K. Tokuda, and A. W. Black, “Statistical parametric speech synthesis,” *speech communication*, vol. 51, no. 11, pp. 1039–1064, 2009.
16. Q. Xie, X. Tian, G. Liu, K. Song, L. Xie, Z. Wu, H. Li, S. Shi, H. Li, F. Hong, H. Bu, and X. Xu, “The multi-speaker multi-style voice cloning challenge 2021,” in *Proc. ICASSP*. IEEE, 2021.
17. M. McAuliffe, M. Socolof, S. Mihuc, M. Wagner, and M. Sonderegger, “Montreal Forced Aligner: Trainable Text-Speech Alignment Using Kaldi,” in *Interspeech*, 2017, pp. 498–502.
18. D. P. Kingma and J. Ba, “Adam: A method for stochastic optimization,” in *Proc. ICLR*, San Diego, 2015.
19. A. Vaswani, N. Shazeer, N. Parmar, J. Uszkoreit, L. Jones, A. N. Gomez, Ł. Kaiser, and I. Polosukhin, “Attention is all you need,” in *Proc. NIPS*, Long Beach, 2017.