

# HarDNet-DFUS: An Enhanced Harmonically-Connected Network for Diabetic Foot Ulcer Image Segmentation and Colonoscopy Polyp Segmentation

Ting-Yu Liao \*, Ching-Hui Yang \*, Yu-Wen Lo \*,  
Kuan-Ying Lai, Po-Huai Shen, and Youn-Long Lin

Department of Computer Science, National Tsing Hua University, Hsinchu, TAIWAN  
{wendy107062324, hui09080729, wagw1014, kytimmylai}@gapp.nthu.edu.tw,  
ty2134029@gmail.com, ylin@cs.nthu.edu.tw

**Abstract.** We present a neural network architecture for medical image segmentation of diabetic foot ulcers and colonoscopy polyps. Diabetic foot ulcers are caused by neuropathic and vascular complications of diabetes mellitus. In order to provide a proper diagnosis and treatment, wound care professionals need to extract accurate morphological features from the foot wounds. Using computer-aided systems is a promising approach to extract related morphological features and segment the lesions. We propose a convolution neural network called HarDNet-DFUS by enhancing the backbone and replacing the decoder of HarDNet-MSEG, which was SOTA for colonoscopy polyp segmentation in 2021. For the MICCAI 2022 Diabetic Foot Ulcer Segmentation Challenge (DFUC2022), we train HarDNet-DFUS using the DFUC2022 dataset and increase its robustness by means of five-fold cross validation, Test Time Augmentation, etc. In the validation phase of DFUC2022, HarDNet-DFUS achieved 0.7063 mean dice and was ranked third among all participants. In the final testing phase of DFUC2022, it achieved 0.7287 mean dice and was the first place winner. HarDNet-DFUS also deliver excellent performance for the colonoscopy polyp segmentation task. It achieves 0.924 mean Dice on the famous Kvasir dataset, an improvement of 1.2% over the original HarDNet-MSEG. The codes are available on <https://github.com/kytimmylai/DFUC2022> (for Diabetic Foot Ulcers Segmentation) and <https://github.com/YuWenLo/HarDNet-DFUS> (for Colonoscopy Polyp Segmentation).

**Keywords:** Medical Imaging · Diabetic Foot Ulcer Image Segmentation · Colonoscopy Polyp Segmentation · Deep Learning · Neural Network.

## 1 Introduction

Diabetes is a global epidemic, and it is estimated that by the end of 2045, approximately 600 million people will have diabetes. Diabetic Foot Ulcers (DFU)

---

\* These authors contributed equally to this work

is one of the complications of diabetes, often leading to more serious conditions such as infection and ischemic, which can significantly prolong treatment and often lead to amputation and, in more severe cases, death. In current practice, medical professionals primarily use manual measurement tools to visually examine and evaluate patients with DFU to determine its severity. However, this is not only time consuming but also challenging for podiatrists. Therefore, it becomes important to fast and accurately determine the exact region of the ulcer.

In recent years, based on the rapid development of convolutional neural networks, many deep learning techniques have been applied in the field of medical imaging. For this task, U-Net [15] employs an encoder-decoder architecture that has achieved breakthrough performance and stimulated many improvements, such as ResUNet++ [12], DoubleU-Net [10], UNet++ [25], etc. However, the overly complex network architecture, low accuracy of small target segmentation, and slow segmentation speed have limited the practical deployment of U-Net variants in the clinical field.

Therefore, based on the previously state-of-the-art HarDNet-MSEG [9] for colonoscopy polyp segmentation, we enhance its backbone incorporating the concept of CSPNet [20] and ShuffleNetV2 [14], and employ a new decoder introduced in the Lawin Transformer[23]. We called the resultant network HarDNet-DFUS. It improves the capability of detecting ulcer regions and can deliver better accuracy compared to the original HarDNet-MSEG.

The contributions of this study can be summarized as follows: First, we have improved the HarDNet-MSEG model to achieve better performance in ulcer region segmentation. Second, we have enhanced the HarDNet [3] backbone to achieve higher accuracy while keeping a similar speed. Third, we have evaluated the proposed method using the single-class segmentation tasks of the DFUC 2022 Challenge.

## 2 Method

Fig.1 depicts the original HarDNet-MSEG (a) and our enhanced model (b). Our enhancement includes modifying each HarDBlk module in the encoder backbone with a new HarDBlkV2 module and replacing RFB modules in the decoder with that of Lawin Transformer[23].

### 2.1 HarDNetV2 – Channel Balanced HarDNet

HarDNet-MSEG’s backbone consists of basic building blocks called HarDBlock. Our enhanced backbone incorporates ideas from CSPNet and ShuffleNetV2, and we call it HarDBlockV2 as depicted in Fig. 2. To achieve the best MACs over CIO ratio (MoC), we perform channel splitting on the outputs of a convolutional layer  $l$  according to its number of output connections. This makes the number of input channels equal to the number of output channels for each Conv3x3 layer. According to the design principle of HarDNet, the amount of DRAM access could be reduced.

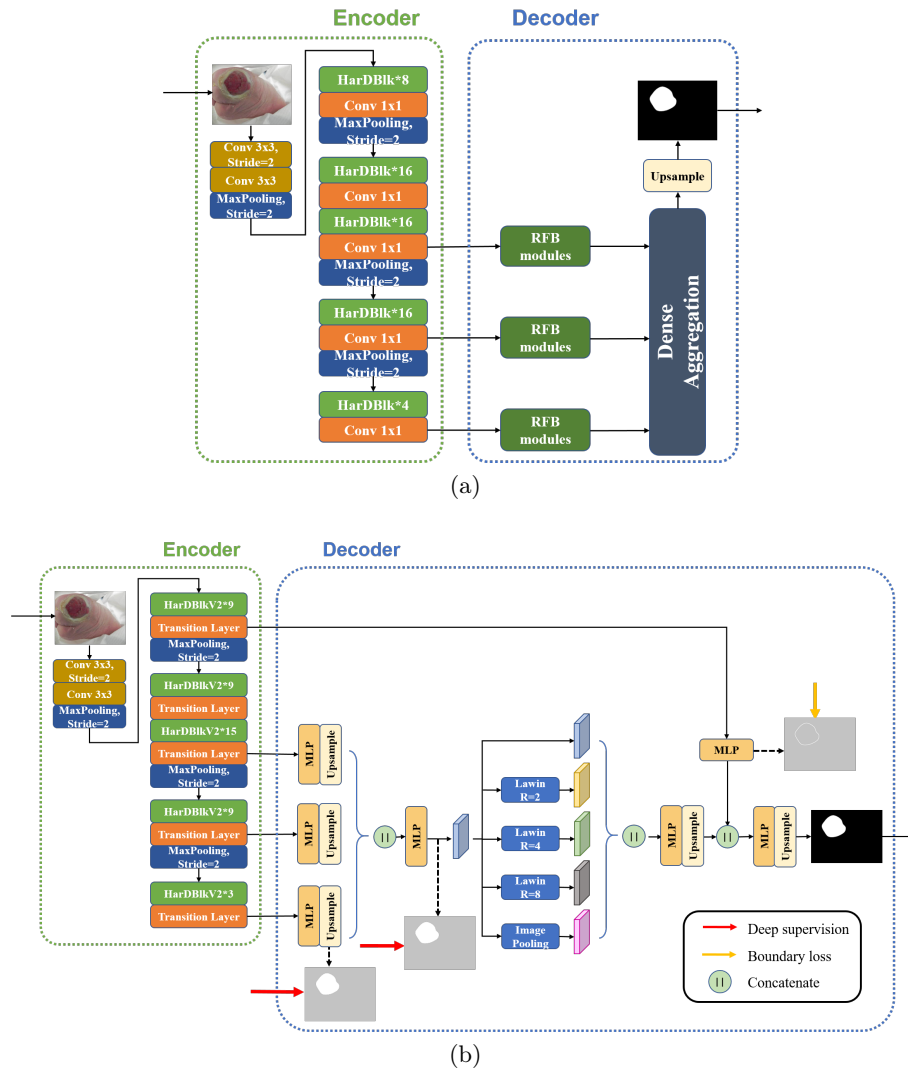

Fig. 1: (a) Original HarDNet-MSEG model, (b) Enhanced model by replacing HarDBlock with HarDBlockV2 and replacing RFB modules with the decoder of Lawin Transformer.

In addition, we propose a new link pattern that simplifies the network architecture design. We build the inter-layer connections according to the factors of the desired block depth  $n$ . For example, when  $n=9$ , its factors are 1, 3, and 9, so we create shortcuts to 1st, 3rd, and 9th convolutional layers. By doing so, the depth of a basic building block in HarDNetV2 is no longer constrained to the power of 2. Instead of 4, 8, or 16 employed by HarDBlock, we choose block

depth  $n=3, 9,$  and  $15$  to build HarDBlockV2, resulting in less data movement with the same number of convolutional layers.

In the transition layer, we add an SE attention module [8] after the block output as shown in Fig. 2(c). Because the block output concatenates some outputs from preceding layers, the attention module facilitates utilization of multi-scale information.

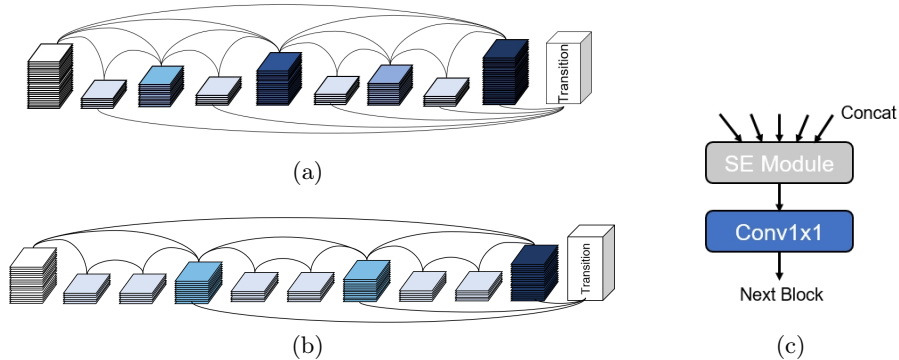

Fig. 2: (a) HarDNet’s basic building HarDBlock ( $n=8$ ); (b) Enhanced basic building block HarDBlockV2 ( $n=9$ ); (c) Transition Layer

## 2.2 Decoder

HarDNet-MSEG was designed for real-time application of colonoscopy examination. Therefore, it trades accuracy for speed. For an accuracy-oriented non-real-time task such as foot ulcer segmentation, we choose a more powerful decoder to obtain higher accuracy. The authors of Lawin Transformer [23] proposed an attention mechanism called Large Window Attention. It utilizes MLP Decoder [22], MLP-Mixer [18], and Spatial Pyramid Pooling(SPP) [7] to capture multi-scale features. Its abundant scale and attention can represent the segmentation result more precisely than the RFB decoder of HarDNet-MSEG does.

## 2.3 Model Ensemble

To increase the inference accuracy, our ensemble strategy adopts 5-fold cross validation and Test Time Augmentation(TTA). The dataset is randomly partitioned into five folds of 400 images each. For each cross-fold iteration, four folds are used for training and the remaining one for validation. After five iterations, we obtain five sub-models. During inference, we perform TTA on each sub-model. That is, to generate an additional image via image flipping, feed both the test images and the additional image to these sub-models, and then take the average of their outputs as our prediction results.

## 2.4 Loss Function

Our loss function for DFUC2022 segmentation challenge is given in Eq. (1), which calculates the loss between the ground truth  $G$ , the output  $O$  of our model, the output  $D_i$  of the deep supervision, and the output  $B$  of the boundary.

$$L = l(G, O) + \sum_i l(G, D_i) + l_{BCE}(G_B, B) \quad (1)$$

where  $l(G, O) = l_{BCE}^w(G, O) + l_{IoU}^w(G, O)$ , and  $l_{IoU}^w$  and  $l_{BCE}^w$  denote weighted IoU loss and weighted BCE loss, respectively. These two functions have the same definition as that of [21].  $l_{BCE}(G_B, B)$  calculates the loss between the prediction boundary and the ground truth boundary.

## 2.5 Post-Processing

We pass the output through the Tanh function and normalize the result into the range  $[0, 1]$  and round to  $\{0, 1\}$  to represent a mask. The last step is hole filling. We first flood-fill the mask prediction from point  $(0, 0)$ , then invert it as invertmask. Finally, we OR the original mask and invertmask to get the hole-filled image as our final mask images.

# 3 Experiments

## 3.1 Setting

For Diabetic Foot Ulcer Image Segmentation, we train the proposed models on a single NVIDIA Tesla V100 GPU. The batch size is 6 and learning rate is 1e-4 with cosine annealing schedule. Training the model for 300 epochs takes about 15 hours. To keep their original aspect ratio, the training images are zero-padded into square and then resized to  $512 \times 512$ . We also employed multi-scaling. The image would be randomly resized into multiples of 64 between  $384(512 \times 0.75)$  and  $640(512 \times 1.25)$ .

Data augmentation includes random vertical flipping, horizontal flipping, cropping, shifting, scaling, rotation, coarse dropout, brightness changing, contrast changing, and Gaussian noise introduction.

Our measurement metric is dice coefficient, which is widely used in segmentation task.

## 3.2 Dataset

For Diabetic Foot Ulcer Image Segmentation, the DFUC2022 dataset [2,4,5,6,13,24] is provided by the organizer of MICCAI 2022 Diabetic Foot Ulcer Challenge. It contains 2,000  $640 \times 480$  images with single-class ulcer segmentation labels.

For colonoscopy polyp segmentation, we use Kvasir-SEG [11], CVC-ClinicDB [1], CVC-ColonDB [17], ETIS-Larib Polyp DB [16], and EndoScene [19].

### 3.3 Experiment Results

**MICCAI DFUC 2022 Challenge** The following evaluation results are our submissions during the validation phase of DFUC2022. First, we study the representation power of the new backbone by simply replacing HarDNet-MSEG’s original backbone, HarDNet, with the new one, HarDNetV2, while keeping everything else unchanged. Table 1 shows our new backbone gained 1% accuracy while keeping a similar speed.

Table 1: Effectiveness of new backbone

| Model            | Dice          | FPS |
|------------------|---------------|-----|
| HarDNet-MSEG     | 0.6553        | 108 |
| HarDNetV2-53-RFB | <b>0.6651</b> | 104 |

We then study the effectiveness of model ensemble. Table 2 shows the mean dice improvement after using 5-fold cross validation. Five-fold ensemble gives the new network 0.8% accuracy gain.

Table 2: Effectiveness of 5-fold cross-validation and ensemble

| Model            | 5-Fold | Dice          |
|------------------|--------|---------------|
| HarDNetV2-53-RFB |        | 0.6651        |
|                  | ✓      | <b>0.6730</b> |

In Table 3, we further compare different combinations of backbones and decoders. Two versions of new backbones, HarDNetV2-53 and HarDNetV2-CSP69, and two versions of decoders, RFB module and Lawin decoder, are investigated. We designate the best architecture HarDNet-DFUS, i.e., the one with HarDNetV2 backbone (53 convolution layers) and Lawin decoder.

Table 3: Results of different combinations of new backbone sizes and decoder types

| Model                             | 5-Fold | Dice          |
|-----------------------------------|--------|---------------|
| HarDNetV2-53-RFB                  | ✓      | 0.6730        |
| HarDNetV2-CSP69-RFB               | ✓      | 0.6842        |
| HarDNetV2-53-Lawin (HarDNet-DFUS) | ✓      | <b>0.6950</b> |
| HarDNetV2-CSP69-Lawin             | ✓      | 0.6870        |

Fig. 3 shows the loss and dice of HarDNet-DFUS during training in one of five folds. We plot the loss, deep supervision loss(deep1 and deep2), boundary loss(boundary loss), mean dice(dice), the current best dice(best dice) and the validation loss(val\_loss) at each epoch.

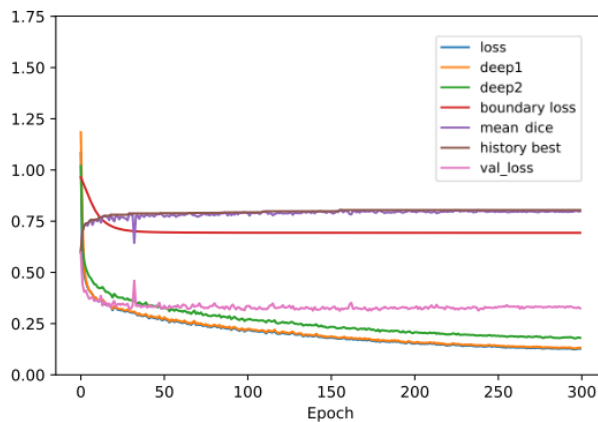

Fig. 3: Training process of HarDNet-DFUS (HarDNetV2-53-Lawin) in one of five folds.

As shown in Table 4 we experiment with different deep supervision. There are two deep supervision losses and one boundary loss. We can see deep supervision loss works when we take more than one to join the training.

Table 4: Segmentation accuracy of HarDNet-DFUS using different combinations of loss functions

| Deep1 | Deep2 | Boundary | Dice          |
|-------|-------|----------|---------------|
|       |       |          | 0.6915        |
| ✓     |       |          | 0.6852        |
| ✓     | ✓     |          | 0.6950        |
| ✓     |       | ✓        | <b>0.7001</b> |
| ✓     | ✓     | ✓        | 0.6927        |

Table 5 compares the effect of test time augmentation (TTA) on different combinations of deep supervision. TTA includes none, horizontal flip, vertical flip, and horizontal flip with a vertical flip. It increases the accuracy in some cases. However, its effect is not robust.

We observe some small values being classified as positive after being compressed by the Sigmoid function, but not by the Tanh function. So we compare Sigmoid and Tanh and show the results in Table 6. Generally, Tanh gives us better results.

Table 5: Effect of Different Test Time Augmentations in HarDNet-DFUS

| Model                             | TTA Method          | Dice          |
|-----------------------------------|---------------------|---------------|
| HarDNet-DFUS                      | none                | 0.6920        |
|                                   | horizontal          | 0.6947        |
|                                   | vertical            | 0.6931        |
|                                   | horizontal+vertical | <b>0.6975</b> |
| HarDNet-DFUS+Deep1+Deep2          | none                | 0.6950        |
|                                   | horizontal          | 0.6958        |
|                                   | vertical            | <b>0.6992</b> |
|                                   | horizontal+vertical | 0.6943        |
| HarDNet-DFUS+Deep1+Boundary       | none                | <b>0.7001</b> |
|                                   | horizontal          | 0.6981        |
|                                   | vertical            | 0.6934        |
|                                   | horizontal+vertical | 0.6928        |
| HarDNet-DFUS+Deep1+Deep2+Boundary | none                | 0.6927        |
|                                   | horizontal          | 0.6994        |
|                                   | vertical            | <b>0.7063</b> |
|                                   | horizontal+vertical | 0.6985        |

Table 6: Effects of prediction compression(Sigmoid vs Tanh) in HarDNet-DFUS

| Model  | Compressing Method | Dice          |
|--|--------------------|---------------|
| HarDNet-DFUS+Deep1+Boundary                          | Sigmoid            | 0.6752        |
|  | Tanh               | <b>0.7001</b> |
| HarDNet-DFUS+Deep1+Boundary (w/ hflip)               | Sigmoid            | 0.6834        |
|  | Tanh               | <b>0.6981</b> |
| HarDNet-DFUS+Deep1+Deep2+Boundary (w/ hflip)         | Sigmoid            | 0.6950        |
|  | Tanh               | <b>0.6994</b> |
| HarDNet-DFUS+Deep1+Deep2+Boundary (w/ vflip)         | Sigmoid            | 0.7029        |
|  | Tanh               | <b>0.7063</b> |
| HarDNet-DFUS+Deep1+Deep2+Boundary (w/ vflip & hflip) | Sigmoid            | <b>0.6995</b> |
|  | Tanh               | 0.6985        |

For the validation phase of 2022 MICCAI DFU Challenge, HarDNet-DFUS achieves 0.7063 mean dice and ranked third among 21 participating teams. Table 7 shows the results of our five submissions during the final testing phase. HarDNet-DFUS achieves 0.7287 mean dice and ranked first among all teams. Rather than the poly-oriented HarDNet-MSEG, HarDNet-DFUS has 5% higher mean dice for the DFUC task.

**HarDNet-DFUS for Polyp Segmentation** We study how HarDNet-DFUS perform on the task of polyp segmentation following the training and experiment setup of HarDNet-MSEG[9].



Table 7: Results of five Submissions of HarDNet-DFUS in the Final Testing Phase of 2022 MICCAI DFUC

| Model   | Dice          |
|---|---------------|
| HarDNet-DFUS+Deep1+Boundary                   | 0.7237        |
| HarDNet-DFUS+Deep1+Boundary (w/ hflip)        | 0.7243        |
| HarDNet-DFUS+Deep1+Deep2+Boundary (w/ hflip)  | 0.7273        |
| HarDNet-DFUS+Deep1+Deep2+Boundary (w/ vflip)  | 0.7275        |
| HarDNet-DFUS+Deep1+Deep2+Boundary (w/ vhflip) | <b>0.7287</b> |

In HarDNet-MSEG[9], 1450 training images were used, including 900 images in Kvasir-SEG and 550 images in CVC-ClinicDB. And the testing set has 5 datasets including Kvasir-SEG, CVC-ClinicDB, CVC-ColonDB, ETIS-Larib Polyp DB, and EndoScene. CVC-T is the testing data for EndoScene. Our training input size is 384x384. We train HarDNet-DFUS with AdamW optimizer for 300 epochs and the learning rate is set to 1e-4. The quantitative results of the five popular datasets are shown in Table 8. The results show that HarDNet-DFUS delivers better performance than HarDNet-MSEG on four datasets and retains real-time performance despite using a more complex decoder.

Table 8: HarDNet-DFUS(+Deep1+Deep2+Boundary) improved over HarDNet-MSEG on Popular Polyp Segmentation Datasets.

| Model        | Kvasir       | ClinicDB     | ColonDB      | ETIS         | CVC-T        | FPS        |
|--------------|--------------|--------------|--------------|--------------|--------------|------------|
| HarDNet-MSEG | 0.912        | 0.932        | 0.731        | 0.677        | <b>0.887</b> | <b>108</b> |
| HarDNet-DFUS | <b>0.918</b> | <b>0.939</b> | <b>0.774</b> | <b>0.730</b> | 0.876        | 30         |

## 4 Conclusion and Future Work

For the task of diabetic foot ulcer segmentation, we have proposed enhancing the previously state-of-the-art HarDNet-MSEG polyp segmentation network with a new backbone and a more powerful decoder. We call the new network HarDNet-DFUS. Five-fold cross validation, deep supervision, boundary supervision, and test time augmentation together contribute to about 5% improvement in mean dice compared with the original HarDNet-MSEG. We have participated in the 2022 MICCAI DFUC Challenge and have been awarded the first place winner. HarDNet-DFUS also deliver excellent performance for colonoscopy polyp segmentation. Compared with HarDNet-MSEG, it has better accuracy on Kvasir, CVC-ClinicDB, CVC-ColonDB, and ETIS datasets while retaining real-time speed.

In the future, we would like to deploy HarDNet-DFUS in clinical fields and expand its application scope to more medical imaging tasks.

**Acknowledgements** This research is partially supported by the Ministry of Science and Technology (MOST) of Taiwan. We thank the National Center for High-performance Computing (NCHC) for computational and storage resources. We would also like to thank Professor Tzu-Chen Dorothy Yen and Professor Chang-Fu Kuo of Chang-Gang Memorial Hospital for their advice.

## References

1. Bernal, J., Sánchez, F.J., Fernández-Esparrach et al., G.: Wm-dova maps for accurate polyp highlighting in colonoscopy: Validation vs. saliency maps from physicians. *Computerized Medical Imaging and Graphics* (2015)
2. Cassidy, B., Reeves, N.D., Joseph, P., Gillespie, D., O’Shea, C., Rajbhandari, S., Maiya, A.G., Frank, E., Boulton, A., Armstrong, D., et al.: Dfuc2020: Analysis towards diabetic foot ulcer detection. *arXiv preprint arXiv:2004.11853* (2020)
3. Chao, P., Kao, C.Y., Ruan, Y.S., Huang, C.H., Lin, Y.L.: Hardnet: A low memory traffic network. In: *Proceedings of the IEEE/CVF conference on ICCV* (2019)
4. Goyal, M., Reeves, N.D., Davison, A.K., Rajbhandari, S., Spragg, J., Yap, M.H.: Dfunet: convolutional neural networks for diabetic foot ulcer classification. *IEEE Transactions on Emerging Topics in Computational Intelligence* pp. 1–12 (2018). <https://doi.org/10.1109/TETCI.2018.2866254>
5. Goyal, M., Reeves, N.D., Rajbhandari, S., Yap, M.H.: Robust methods for real-time diabetic foot ulcer detection and localization on mobile devices. *IEEE Journal of Biomedical and Health Informatics* **23**(4), 1730–1741 (July 2019). <https://doi.org/10.1109/JBHI.2018.2868656>
6. Goyal, M., Reeves, N.D., Rajbhandari, S., Ahmad, N., Wang, C., Yap, M.H.: Recognition of ischaemia and infection in diabetic foot ulcers: Dataset and techniques. *Computers in Biology and Medicine* **117**, 103616 (2020). <https://doi.org/https://doi.org/10.1016/j.combiomed.2020.103616>, <http://www.sciencedirect.com/science/article/pii/S0010482520300160>
7. He, K., Zhang, X., Ren, S., Sun, J.: Spatial pyramid pooling in deep convolutional networks for visual recognition. *IEEE transactions on pattern analysis and machine intelligence* **37**(9), 1904–1916 (2015)
8. Hu, J., Shen, L., Sun, G.: Squeeze-and-excitation networks. In: *Proceedings of the IEEE conference on computer vision and pattern recognition*. pp. 7132–7141 (2018)
9. Huang, C.H., Wu, H.Y., Lin, Y.L.: Hardnet-mseg: a simple encoder-decoder polyp segmentation neural network that achieves over 0.9 mean dice and 86 fps. *arXiv preprint arXiv:2101.07172* (2021)
10. Jha, D., Riegler, M.A., Johansen, D., Halvorsen, P., Johansen, H.: Doubleu-net: A deep convolutional neural network for medical image segmentation. In: *CBMS. IEEE* (2020)
11. Jha, D., Smedsrud, P.H., Riegler et al., M.A.: Kvasir-seg: A segmented polyp dataset. In: *International Conference on Multimedia Modeling*. Springer (2020)
12. Jha, D., Smedsrud, P.H., Riegler et.al, M.A.: Resunet++: An advanced architecture for medical image segmentation. In: *ISM. IEEE* (2019)
13. Kendrick, C., Cassidy, B., Pappachan, J.M., O’Shea, C., Fernandez, C.J., Chacko, E., Jacob, K., Reeves, N.D., Yap, M.H.: Translating clinical delineation of diabetic foot ulcers into machine interpretable segmentation (2022)
14. Ma, N., Zhang, X., Zheng, H.T., Sun, J.: Shufflenet v2: Practical guidelines for efficient cnn architecture design. In: *Proceedings of the ECCV* (2018)

15. Ronneberger, O., Fischer, P., Brox, T.: U-net: Convolutional networks for biomedical image segmentation. In: MICCAI. Springer (2015)
16. Silva, J., Histace, A., Romain, O., Dray, X., Granado, B.: Toward embedded detection of polyps in wce images for early diagnosis of colorectal cancer. *International journal of computer assisted radiology and surgery* **9**(2), 283–293 (March 2014). <https://doi.org/10.1007/s11548-013-0926-3>, <https://doi.org/10.1007/s11548-013-0926-3>
17. Tajbakhsh, N., Gurudu, S.R., Liang, J.: Automated polyp detection in colonoscopy videos using shape and context information. *IEEE transactions on medical imaging* (2015)
18. Tolstikhin, I.O., Houlsby, N., Kolesnikov, A., Beyer, L., Zhai, X., Unterthiner, T., Yung, J., Steiner, A., Keysers, D., Uszkoreit, J., et al.: Mlp-mixer: An all-mlp architecture for vision. *Advances in Neural Information Processing Systems* **34**, 24261–24272 (2021)
19. Vázquez, D., Bernal, J., Sánchez, F.J., Fernández-Esparrach, G., López, A.M., Romero, A., Drozdal, M., Courville, A.C.: A benchmark for endoluminal scene segmentation of colonoscopy images. *CoRR abs/1612.00799* (2016), <http://arxiv.org/abs/1612.00799>
20. Wang, C.Y., Liao, H.Y.M., Wu, Y.H., Chen, P.Y., Hsieh, J.W., Yeh, I.H.: Cspnet: A new backbone that can enhance learning capability of cnn. In: *Proceedings of the IEEE/CVF conference on CVPR workshops* (2020)
21. Wei, J., Wang, S., Huang, Q.: F<sup>3</sup>net: fusion, feedback and focus for salient object detection. In: *Proceedings of the AAAI Conference on Artificial Intelligence* (2020)
22. Xie, E., Wang, W., Yu, Z., Anandkumar, A., Alvarez, J.M., Luo, P.: Segformer: Simple and efficient design for semantic segmentation with transformers. *Advances in Neural Information Processing Systems* **34**, 12077–12090 (2021)
23. Yan, H., Zhang, C., Wu, M.: Lawin transformer: Improving semantic segmentation transformer with multi-scale representations via large window attention. *arXiv preprint arXiv:2201.01615* (2022)
24. Yap, M.H., Cassidy, B., Pappachan, J.M., O’Shea, C., Gillespie, D., Reeves, N.D.: Analysis towards classification of infection and ischaemia of diabetic foot ulcers. In: *2021 IEEE EMBS International Conference on Biomedical and Health Informatics (BHI)*. pp. 1–4. IEEE (2021)
25. Zhou, Z., Rahman Siddiquee, M.M., Tajbakhsh, N., Liang, J.: Unet++: A nested u-net architecture for medical image segmentation. In: *Deep learning in medical image analysis and multimodal learning for clinical decision support*. Springer (2018)