

# Implementing packet trimming support in hardware

Adrian Popa<sup>\*</sup>, Dragos Dumitrescu<sup>\*‡</sup>, Mark Handley<sup>°\*</sup>,  
Georgios Nikolaidis<sup>△</sup>, Jeongkeun Lee<sup>△</sup>, Costin Raiciu<sup>\*‡</sup>

<sup>\*</sup> *Correct Networks*, <sup>°</sup> *UCL*, <sup>△</sup> *Intel*, <sup>‡</sup> *University Politehnica of Bucharest*

## ABSTRACT

Packet trimming is a primitive that has been proposed for datacenter networks: to minimize latency, switches run small queues; when the queue overflows, rather than dropping packets the switch trims off the packet payload and either forwards the header to the destination or back to the source. In this way a low latency network that is largely lossless for metadata can be built.

Ideally, trimming would be implemented as a primitive in switch ASICs, but hardware development cycles are slow, costly, and require demonstrated customer demand. In this paper we investigate how trimming can be implemented in existing programmable switches which were not designed with trimming in mind, with a particular focus on a P4 implementation on the Tofino switch ASIC. We show that it is indeed possible to closely approximate idealized trimming and demonstrate that trimming can be integrated into a production-grade datacenter switch software stack.

## 1 INTRODUCTION

Congestion control algorithms rely on network feedback to adjust the sending rate to match and adequately share available capacity. While in the Internet such feedback is almost always packet-loss, datacenter networks enable the deployment of a wider range of congestion feedback including ECN marking and link-layer priority flow control for intra-datacenter traffic, as each datacenter is managed by a single organisation.

The available type of congestion feedback, coupled with buffer sizing, has a direct effect on the performance of congestion control algorithms. In datacenters, loss-based congestion controllers need very large buffers (megabytes) to cope with bursty many-to-one traffic (incast), or they suffer congestion collapse [12, 1]; large (shared) buffers however add latency to innocent traffic on the same egress port. ECN marking helps reduce buffer usage for long-running flows, while still needing large buffers to absorb incast bursts [1]. Priority Flow Control eliminates congestion-related packet-loss so it is apparently ideal for incast traffic, but it can delay innocent traffic and result in poor throughput; it is often used with large buffers and in conjunction with ECN, to avoid triggering frequently [13].

In summary, the congestion feedback mechanisms available in production today force congestion controllers to tiptoe around a tradeoff between utilization, latency and loss on

one hand, and between solving particular problematic traffic patterns such as incast and causing damage to bystander traffic crossing the same switches. Recent research papers have however shown that, with the network hardware support for queue overload, it is possible to build stacks that achieve high utilisation, have almost perfect incast behaviour without hurting innocent traffic all the while using small packet buffers [5, 2, 8, 9, 6, 10].

One very promising overload behaviour is packet trimming, where switches send control information (in the form of packet headers) to the destination or the source of the traffic when an output queue is full [5, 2, 8]: instead of dropping or marking the packet, trimming removes the payload and only forwards the header, typically with priority, to the destination or the source, depending on the scheme chosen. The benefit of trimming is that it allows very small per port buffers to be used (10-20 packets [5, 10]) while ensuring packet headers are not lost so hosts know unambiguously what happened to a packet. Trimming enables the creation of host stacks that are near-optimal for all traffic patterns, including incast and permutation, effectively turning datacenter networks into an approximation of a perfect non-blocking switch connecting all hosts [5, 10].

Can endhost stacks use trimming in real datacenter networks? Existing works provided NetFPGA or software switch implementations [5, 2], but these are neither fast nor stable enough for use in production networks. An ASIC implementation would be ideal, together with the control hooks, but hardware development cycles are slow (years), costly and typically require strong interest from potential customers before any investment from hardware vendors. A quicker and indeed workable deployment approach is to use existing switch functionality, either programmable or fixed-function, to implement trimming or approximations of it.

In this paper we analyze to what extent trimming can be supported on production switches today. We find that, surprisingly, many switches being used in production do have the building blocks needed to support packet trimming, namely the ability to mirror/deflect packets about to be dropped and the ability to only copy the header of the dropped packet; this header can then be enqueued in a higher priority queue on the same output port, typically after being recirculated through

the switch. Such functionality is broadly available in production switches; it is used by operators to help monitor packet losses in their networks by aggregating drop information to a centralized monitor.

Mirror-on-drop is thus a generic approach that can implement trimming on a variety of switch architectures; this strategy, however, does have some limitations which stem from the architecture of the switches; these limitations can make the hardware implementation of trimming significantly differ from the ideal behaviour. We analyze these limitations in simulation, and then propose a concrete design for Intel's Tofino switching ASIC that provides trimming support. Our evaluation shows that it is possible to build an almost ideal implementation of trimming in hardware.

## 2 PACKET TRIMMING OVERVIEW

The concept of packet trimming was first suggested as cut payload[2], where instead of dropping a packet a switch simply cuts the payload and forwards only the packet header. NDP [5] refined this concept to avoid potential livelock situations and to provide early negative acknowledgments, allowing a trimmed packet to be retransmitted sufficiently quickly that when a switch queue only just overflows due to a small burst, the resent packet can reach the queue before it has had time to drain, ensuring that the trimming has no negative impact. NDP does this by queuing the trimmed packet header in a higher priority queue than untrimmed data packets.

Ideally, strict priority queuing is not used with NDP, but rather a byte-based weighted fair queuing regime should be used instead. This ensures that some data packets are still forwarded when many packets are being trimmed, but all the early trimmed headers will jump the queue of data packets. This provides improved performance and eliminates livelock in extreme circumstances.

Trimming can still lead to header drops in extreme circumstances when the per port header buffer is already full; this happens in incasts with thousands of senders. In such cases, the NDP paper proposed that the header should be returned to the sender instead, to avoid dropping it.

Recently, the header return-to-sender approach has been proposed as a standalone solution called Source Flow Control (SFC) [8], where the trimmed headers start to be returned to the sender when the queue passes a threshold, rather than only when it cannot be forwarded to the destination. SFC is undergoing standardization at the IEEE.

In summary, packet trimming is a switch-based feature that behaves as follows:

- (1) When an output port buffer is full (NDP, SFC) or when some watermark has been hit (CP, SFC), trim the packet to its header instead of dropping it,
- (2) Optionally set some bits in the trimmed header (i.e.

trimmed bit in NDP).

- (3) Optionally reverse the source and destination addresses for return-to-sender operation (SFC, NDP when the header queue is full).
- (4) Enqueue the resulting header either in (a) the same output queue (CP); (b) a higher priority queue (NDP); (c) the output queue destined for the original sender (SFC, NDP when the header queue is full).

### 2.1 Benefits of packet trimming

Trimming allows very small data packet queues (as low as ten MTU-sized packets [5, 10]) to be used in datacenter switches, guaranteeing that packets cannot be queued within the network for any significant amount of time. As packets are almost never dropped entirely, the receiver gains a complete view of the instantaneous demand from all senders (when the headers are sent forward) and the senders very quickly receive feedback from receivers or the switches as to a packet's fate, avoiding the need for conservative retransmission timers to prevent congestion collapse. Such conservative timers typically have a detrimental affect on performance [12].

As packet headers are generally not lost, trimming allows higher-layer protocols to use per-packet ECMP[3] (packet spraying) without the risk of confusing reordering with packet loss. This allows networks using Clos or similar redundant topologies to be load-balanced much more effectively, avoiding flow collisions which have been shown to reduce throughput in the worst case by as much as 60% [4, 11].

Trimming is especially effective with incast traffic patterns because it does not require a tradeoff between queue latency and packet loss. Switch buffers can be kept very small yet there is (almost) no packet loss with incast; instead only the packet payload is dropped, allowing senders to know the fate of their packets almost immediately.

Prior works have shown that trimming enables near-perfect network utilization, incast behaviour and short flow completion times, at scale [5, 10], providing a big improvement over the status quo represented by DCTCP [1], DCQCN [13], MPTCP [11].

Trimming, then, is a very effective basic building block for datacenter networks. Unfortunately current network switches were not designed to support trimming, which leaves protocol designers with a chicken-and-egg problem: they cannot design protocols to assume short queues and use per-packet ECMP because they cannot assume trimming will be available; at the same time switch vendors have no demand from customers for trimming support because no protocols could take advantage.

Fortunately this cycle can be broken today by implementing trimming support in current programmable switches, but doing so is not completely trivial.

# Implementing packet trimming support in hardware

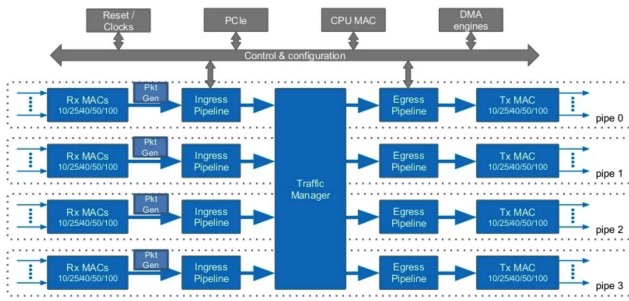

Figure 1: Simplified Tofino block diagram.

## 3 IMPLEMENTING TRIMMING IN PROGRAMMABLE SWITCHES

Trimming is conceptually a function of an output-queued switch where trimming is done when attempting to enqueue and the queue is either full or has reached a predefined watermark. To emulate this in a programmable switch, we need to consider the switch architecture. The building blocks at our disposal may differ somewhat between different programmable switches. For example, a Tofino switch consists of four programmable ingress pipelines, each fed from sixteen 100 Gb/s ingress ports, a central traffic manager which implements queuing and interconnection between pipelines, and then four programmable egress pipelines each feeding sixteen 100Gb/s egress ports, as shown in Figure 1. Note that trimming cannot be implemented in the egress pipelines leading to the egress port because these pipelines are downstream of the queues; it should ideally be implemented in the traffic manager (not programmable) or in the ingress pipeline where queue information is lacking.

**Deflect-on-Drop.** Many switches feature a form of *deflect-on-drop* (DoD) functionality in their equivalent of the traffic manager. When the queue for an egress port fills, the traffic manager can be configured to deflect the packet to another port instead of dropping it. DoD is implemented primarily to enable network operators to analyze the packets that were dropped, and is supported by most switches, not just programmable ones. Our strategy is to re-use this functionality to deflect packets that would have been dropped to an internal port used for recirculation. We refer to this internal port as the DoD port. How can we use this for trimming?

Intel Tofino and Tofino 2 switching ASICs support deflect-on-drop, but deflected packets carry their full payload and not just the headers. Tofino-based switches have internal recirculation ports for each pipeline which we can use to forward deflected traffic. This recirculated traffic can then be trimmed to the desired length using mirroring. On Tofino, for example, this means that we can recirculate up to 100Gb/s of untrimmed packets using one dedicated internal port per pipeline. If all ports on the same ingress pipeline start sending to a single egress port, that port will be oversubscribed 16:1. 1.5Tb/s of

traffic would then be deflected to the same DoD port, resulting in a large queue followed shortly by large packet loss. Thus in the Tofino family of switches, we need to prevent such large overloads of DoD capacity from happening in the first place.

Some switches including the Broadcom Trident 4 and NVidia Spectrum 2 additionally support the ability to configure their equivalent of the traffic manager to *mirror just the packet header* into a DoD queue. Once there, the header can be recirculated and then queued in a priority header queue for the original destination port (NDP) or the port back to the sender (SFC). In such a switch, trimming largely happens in the traffic manager with any additional processing such as setting a trimmed bit (NDP) or swapping addresses (SFC) happening in the DoD pipeline before recirculation. One downside of such an implementation is that trimmed packets must all be recirculated, so they will be delayed by a few packets relative to non-trimmed packets. This is overall a good approximation but as we will see in Subsection 6.1, we can take advantage of Tofino's programmability to improve performance even further.

**Trimming in ingress.** If the ingress pipelines had access to the instantaneous queue size for traffic from all ingress ports to the respective egress port, then trimming might be performed in P4 in the ingress pipelines. In Tofino 2, such queue length information is available at registers in the ingress pipelines, which are updated by a thread separate to the normal switching control with minimal feedback delay compared to recirculation [7].

With queue size information available, when an incast occurs and the queue size reaches the target threshold, trimming can begin in the ingress pipeline. However a P4 program performing trimming must read the queue size in an early stage to decide a packet's fate. When trimming starts, there can already be multiple packets in the later stages of the ingress pipelines that have not yet been enqueued and are not account for in the queue size information. For example, if there are four pipeline stages downstream of the stage reading the queue size, and eight pipelines in our switch, there may be at most 32 untrimmed packets that will hit the output queue after the switch starts trimming. Most of these packets will then be deflected to the recirculation ports. On Tofino 2, we can use one recirculation port for each eight ingress ports, so the DoD queues will grow to about 4 packets each, before dropping back after ingress-trimmed packets start reaching the output queue. Compared to a mirror-on-drop solution, most trimmed packets on such a Tofino 2 implementation will be ingress trimmed and so see lower latency, but some at the start of an incast that traverse DoD will see higher latency due to the build-up of the DoD queue.

The situation is more complicated on Tofino, where queue size information is unavailable to the ingress pipeline. We can still perform trimming, but we need to be a little smarter in

how we go about doing it. We can keep track of all the traffic destined for each output port using software in the ingress pipeline. To do this we use a *meter* to emulate a virtual output queue for each egress port; when that virtual queue fills, we trim the packet before it goes to the traffic manager for buffering. This solution eliminates the lag seen when reading the real queue size, so packets trimmed in this way see the lowest latency of all the solutions.

Unfortunately though, there is a downside: meter information cannot be shared between ingress pipelines on Tofino. The fact that information is local to a pipeline is not fundamental in programmable switches, but to perform at very high speeds it is necessary to parallelize hardware, and any shared state between parallel building blocks is a potential bottleneck. What are the implications of this, and what can we do despite this constraint?

Suppose we implement meter-based trimming independently on each ingress pipeline. If all the traffic for an output port came from a single ingress pipeline, all trimming would occur in the ingress pipeline, perfectly matching our output-queued trimming ideal. The problem arises when traffic arrives via multiple ingress pipelines destined for one output port. Each ingress pipeline will trim assuming it is the only source of traffic, but the resultant trimmed packet stream will overflow the egress port queue in the traffic manager. These excess packets will then be deflected to the DoD ports. With meter-based ingress trimming reducing the overload, is there enough DoD capacity to cope?

On Tofino, we can use one recirculation port for each of four ingress pipelines, and each pipeline has sixteen ingress ports. One might think that the worst-case traffic pattern for the Tofino DoD pipeline would be when 100Gb/s arrives from 63 input ports destined for a single output port. In this case each ingress pipeline would use its local meter to trim down to 100Gb/s, resulting in 400Gb/s destined for the output port. 100Gb/s will be forwarded directly, leaving 300Gb/s to be redirected to the four recirculation ports on those pipelines. In this case there is enough capacity, and all the remaining trimming is performed there.

In practice such a 63:1 incast is not the worst-case scenario. Consider what happens when 100Gb/s of traffic arrives on port  $p$  on every pipeline destined for port  $(p+1)\%16$  on egress pipeline 0. For example, traffic arrives on ports 0, 16, 32 and 48 all destined for port 1; simultaneously traffic arrives on ports 1, 17, 33 and 49 destined for port 2 and so on, up to traffic arriving on ports 15, 31, 47 and 63 destined for port 0. Effectively sixteen parallel 4:1 incasts occur simultaneously, as shown in Figure 2.

In this case, from the point of view of a single ingress pipeline, only 100Gb/s of traffic arrives for each output port, so no trimming is performed in the ingress pipeline. Now, 400Gb/s of traffic arrives at the traffic manager for each of the

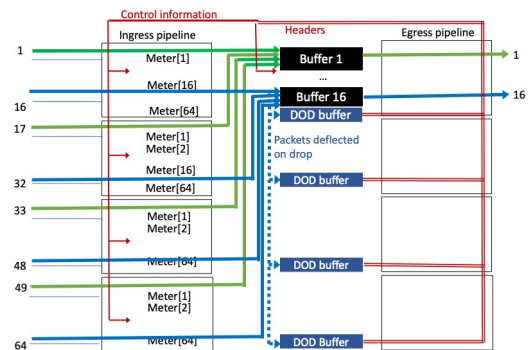

Figure 2: Worst-case DoD Scenario for Tofino

16 output ports targeted. 1.6Tb/s can be forwarded directly, leaving 4.8Tb/s to be diverted to the four recirculation ports, which will be oversubscribed 12x, with their queues rapidly growing, leading to high packet loss.

The challenge of implementing trimming is to handle this 16 x 4:1 incast scenario while simultaneously being as close to optimal as possible in scenarios between this and the 63:1 incast scenario which itself requires no special mechanisms beyond ingress trimming and trimming in the DoD pipeline. To do this requires a control loop that adjusts the trimming rate in the ingress pipelines.

#### 4 TRIMMING CONTROL LOOP DESIGN

DoD is very effective for coping with small transient overloads, but if the queue feeding the recirculation pipeline starts to grow, then DoD itself can become a bottleneck. In such circumstances we require ingress pipeline trimming to become more aggressive.

When the ingress pipeline performs trimming based only on local traffic meters, trimming traffic to match an egress port's link speed, we refer to this as *optimistic mode* as the ingress pipeline is assuming no other traffic for the port exists from other pipelines. When this is not the case, to increase ingress pipeline trimming a congestion signal can be recirculated from the egress pipeline when DoD packets arrive there. This congestion signal should trigger increased packet trimming in the ingress pipeline to prevent the recirculation queue growing excessively.

When evaluating the possible designs our goals are to minimize the number of packets trimmed in excess of those trimmed by an ideal implementation, to ensure quick feedback by keeping recirculation queue sizes small, and to ensure fairness across flows from different pipelines.

**Hard vs soft state.** Once a congestion signal from the recirculation port enables more aggressive trimming, we need a way to go back to optimistic mode when traffic abates and the recirculation queue drains. In principle we could adopt a hard-state approach, sending an "all clear" signal from the

# Implementing packet trimming support in hardware

recirculation port, but this would have to be triggered from a timer or directly from the recirculation queue becoming empty, which would be complex to implement.

The alternative is to adopt a soft-state approach where the congestion signal triggers the congestion response for a predefined amount of time or a predefined number of packets before reverting to regular optimistic mode.

There are two soft-state approaches we could take:

- Each congestion packet instructs the pipeline to trim a *fixed number of packets*; the pipeline goes into pessimistic mode until this number of packets is received and trimmed.
- Each congestion packet instructs the pipeline to go into pessimistic mode for a *fixed period of time*, starting from the receipt of the packet.

**Trim N Packets.** The simplest soft-state mechanism is whenever a packet leaves the recirculation queue of pipeline A, instruct the ingress pipeline of A to trim one packet destined for the same port. Unfortunately the recirculation port only sees packets that make it through the recirculation queue, and packets can be entering this queue much faster than it can drain - 12x faster in the worst case. To handle the worst case then, each packet making it into the recirculation queue would have to trigger a congestion response trimming at least 12 packets.

Trim N is quite simple to implement but is suboptimal: when a large short-duration incast occurs and the recirculation queue fills, as this queue drains it will result in many congestion notification packets being sent to the ingress pipeline, each instructing it to trim at least 12 packets; if  $n$  congestion packets are sent, the pipeline will trim  $12n$  packets.

If the incast is short lived, as would be expected if an end-to-end control loop such as NDP is running, there will be no more incast traffic to trim, and instead these trims will affect other packets an arbitrary time later, reducing goodput and creating an unnecessary coupling between the incast and subsequent unrelated traffic.

**Trim for a time period.** The alternative soft-state mechanism we actually use is for a congestion signal to indicate to trim traffic destined for the specified destination port, starting now, lasting for  $t$  microseconds. This has two advantages: multiple signals arriving right after one another don't greatly change the outcome, and the effect of a short incast is inherently short.

Trimming all packets for duration  $t$  would entail a form of pulse-width modulation. In practice though, with four ingress pipelines on Tofino, we do not need to control to arbitrarily low rates - on a switch with four pipelines and 100Gb/s ports the full control range only needs to operate from 25Gb/s to 100Gb/s per output port per pipeline.

The simplest algorithm then would be for the ingress pipeline to trim traffic to 25Gb/s for  $t$  microseconds on receipt of a

congestion signal. We refer to this 25Gb/s target rate as *pessimistic mode*. This algorithm does work, but we found that the trimming period  $t$  needs to be fairly long to be stable in all circumstances, resulting in some degree of underutilization.

To smooth the rate increase as congestion abates we added a third ingress pipeline trimming mode, so now we have:

- **Optimistic mode:** trim to 100Gb/s
- **Half-pessimistic mode:** trim to 50Gb/s
- **Pessimistic mode:** trim to 25Gb/s

We use three fixed-rate meters in the P4 ingress pipeline to implement these modes and switch between them based on congestion signals from the recirculation port. Each ingress pipeline remembers which mode it is operating in for each output port. One packet arrival, the corresponding meter is used to decide whether or not to trim the packet. When a recirculated congestion signal arrives, the corresponding port is set to pessimistic mode for a predetermined period of time (6us - long enough to trim 12 packets). When this time period expires the port switches to half-pessimistic mode for a further 6us, before returning to optimistic mode if no further congestion signal is received.

**Send signal to all pipelines.** A final design decision is whether the congestion signal should be sent to one pipeline or all of them. The obvious choice is to send the congestion signal only to the pipeline which originated the deflected packet. It turns out that this adds delay to the control loop - the signal takes longer to reach all ingress pipelines - and this necessitates running larger time constants.

We also found that send-to-one can result in unfairness and potential oscillations between pipelines. Consider the following packets in the DoD queue, where a packet is represented by its intended egress port and the front of the queue is at the left:

Pipe 1 DoD: 1,1,1,1,1,1,1,1,2  
Pipe 2 DoD: 2,2,2,2,2,2,2,2,1

Pipe 1 will go into congestion mode for Port 1 for  $8+t$  time slots, and Pipe 2 will do the same for Port 2. During this time, traffic for Port 1 from Pipe 2 can run at line rate, taking 80% of the egress capacity and filling the DoD queue with 1's. Traffic on Port 2 arriving from Pipe 1 can also run at line rate. Beyond the temporary unfairness, such oscillations can continue, preventing the recirculation queues from draining.

As a result we send all congestion signals to all pipelines; this ensures rapid responses across all pipes to queue increases.

## 5 TOFINO IMPLEMENTATION

We have implemented two versions of on Tofino: `ndp.p4` is a standalone IPv4 router with trimming support, the second implementation is fully integrated with `swtch.p4`, a

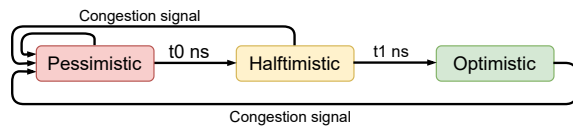

Figure 3: Port trimming state machine

production-grade datacenter switch with SONiC support. `ndp.p4` is more self-contained so we will focus on that first.

**ndp.p4.** This implementation contains a longest-prefix match routing table, an ARP table and a rewriter in egress, plus extensions to support trimming which are mostly in the ingress pipeline.

When a packet overflows the port queue, is deflected, and is detected in egress, a notification packet is sent to all pipelines in ingress on a special recirculation port. When this notification arrives in ingress, the output port which experienced the loss transitions into pessimistic state, as shown in figure 3. In the absence of congestion notification, the port will transition from pessimistic state to half-pessimistic (aka halftimistic) state after time  $t_0$  elapses, and then back to optimistic after  $t_1$ . Any congestion notification causes a transition to pessimistic and restarts the  $t_0$  timeout.

In the ingress pipeline we maintain three stateful meters for each egress port: *meter\_optimistic*, *meter\_pessimistic* and *meter\_halftimistic*. These are used in the corresponding states and meter at line rate, 25% of line rate, and 50% of line rate respectively. We also maintain two registers, *t0\_reg* and *t1\_reg*, which are timestamps for state expiry, as in Figure 3.

The code executed on every ingress packet is sketched out in this pseudo-code:

```

ON DoD got on port egress_port:
    t0_reg[egress_port] = now() + T0
    t1_reg[egress_port] = now() + T1
ON non-DOD packet:
    opticolor=meter_optimistic.execute(egress_port)
    pessicolor=meter_pessimistic.execute(egress_port)
    halfcolor=meter_halftimistic.execute(egress_port)
    color = opticolor
    if now() <= t0_reg[egress_port]:
        color = pessicolor
    else if now() <= t1_reg[egress_port]:
        color = halfcolor
    else:
        color = opticolor
        t0_reg[egress_port] = 0
        t1_reg[egress_port] = 0
    if color == RED:
        trim_packet()

```

**Congestion signaling** To send the congestion signal to all ingress pipelines, we use control messages which are recirculated (figure 4). First, when a deflected packet arrives in egress, we convert it into a control message by trimming its payload and adding a new header at the beginning of the packet. This

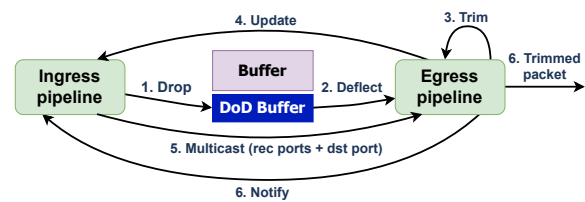

Figure 4: Congestion signaling

new header is used to store information about the original packet and what type of control message it is.

To trim the data packet we use one mirroring session for each pipe. Each sets that pipe’s recirculation port as destination and instructs the traffic manager to trim the packet. The newly trimmed packet forms an UPDATE control packet which will be sent back to ingress in that pipe only.

In the ingress parser we distinguish data packets from UPDATES by looking at the ingress port. When a packet arrives in ingress from the recirculation port, we know that it is an UPDATE and look for the UPDATE header.

When the ingress pipeline receives an UPDATE packet, it uses a multicast group to propagate the congestion signal to all pipes and changes the packet type to NOTIFY. The multicast group contains the recirculation ports of all pipes. NOTIFY packets arriving in egress are recirculated to their respective ingress ports; they instruct each pipe to transition the congested port into *pessimistic* state.

**switch.p4 integration.** The standalone `ndp.p4` is good for testing and evaluation, but lacks many features of a production-grade router. For operational deployments we integrated `ndp.p4` into `switch.p4`, a production-grade datacenter router implementation fully integrated with SAI and SONiC.

We cannot quite insert the standalone implementation of NDP directly into `switch.p4` for several reasons:

- (1) `switch.p4` takes up almost all stages of the Tofino. Fitting extra functionality is challenging.
- (2) `switch.p4` employs custom signaling between ingress and egress pipelines to trigger specific behaviors (bridging information, dataplane telemetry, etc.). Harmonizing the notification mechanisms of `ndp.p4` with existing ones required careful re-design.
- (3) SONiC, the control-plane of `switch.p4` is a very complex piece of software; making NDP fit in this picture is difficult

To free up some resources, the size of some `switch.p4` tables was reduced and some functionality was left out – e.g., dataplane telemetry. Rather than `ndp.p4`’s three `trTCM` meters per port to track the output queue in all states, our `switch.p4` implementation only uses two meters per port.

The first meter (`opt1`) is used in the *optimistic* and *halftimistic* states. We set its Peak Information Rate (PIR) at line rate and the Committed Information Rate (CIR) at half line

# Implementing packet trimming support in hardware

rate. When `opti` outputs red, this indicates that traffic exceeds the line rate of the port it was tracking, whereas yellow indicates that traffic is greater than half line rate but slower than line rate. The second meter (`pesi`) has both rates set at one fourth line rate; its output is only used in *pessimistic* state. Based on the port state and the colors of the meters, we apply one of the actions below:

State	pesi color	opti color	Action
pessimistic	NOT GREEN	*	trim
halftimistic	*	NOT GREEN	trim
optimistic	*	RED	trim
pessimistic	GREEN	*	low prio queue
halftimistic	*	GREEN	low prio queue
optimistic	*	NOT RED	low prio queue

To keep the state of a port, an ingress pipeline register stores the timestamp of the last congestion signal. The maximum size of a register is 32 bits and there are few resources left in switch.p4, so we can store only 32 bits of the pessimistic transition timestamp. A Register Action is used to store the time of the pessimistic transition and another Register Action is used to check how much time has passed since the pessimistic transition. Because of the limited operations allowed in a Register Action, the case where the timestamp overflows could not be included.

```
if tstamp[31:0] > last_pesi_transition + T1:
    last_pesi_transition = 0
    state = OPTIMISTIC
else if (tstamp[31:0] > last_pesi_transition + T0:
    state = HALFTIMISTIC
else:
    state = PESSIMISTIC
```

## 6 EVALUATION

We have been using our Sonic implementation in a leaf-spine testbed with four ToRs and three spines (Tofino switches), with 32 host NIC ports of varying speeds attached in a balanced way to the ToRs. The switches use BGP for routing, where each rack is advertised as a separate prefix.

We have run both high-throughput (storage) and short flow workloads (microservices, memcached) in this setup, obtaining results that closely match the ideal end-to-end behaviour of NDP[5] and EQDS[10] stacks. We include a subset of these results to this paper for completeness; however the main goal of our evaluation is to understand in detail the differences in the possible implementations of trimming and the ideal behaviour as described in the NDP paper[5], with the stated goal of showing that high quality trimming implementations are possible on modern programmable hardware.

Our hardware experiments focus on our Tofino implementation only; other groups have independently implemented trimming with on Broadcom Trident 4 and Nvidia Spectrum

2 switches (via Mirror-on-Drop).

We rely on simulation to understand the merits of the alternative ways of implementing trimming, and to validate the design and parameter choices for our congestion feedback mechanism described in §4.

To this end, we have implemented a model of our Tofino implementation in the `htsim` simulator [5], as well as other mechanisms that support trimming including Mirror-on-Drop, Deflect-on-Drop, ingress meter trimming and so forth. We use simulations to compare the behaviour of a 64 port 100Gbps Tofino switch to that of an idealized NDP switch having 64 ports at 100Gbps.

### 6.1 Basic mechanism comparison

Which is the best way to implement trimming? To understand the tradeoffs, we compare the idealized switch behaviour to:

- A generic Mirror-on-Drop (MoD) switch with a 100Gbps mirror-on-drop port per pipeline, and a recirculation latency of 1us (similar in spirit to Trident 4 and Spectrum implementations of trimming).
- The Tofino with per-destination meters in the ingress pipeline and Deflect-on-Drop in case of queue overload.
- Our full Tofino solution with `pesi` and half meters, as well as notifications from DoD to ingress pipelines.

We use simple incast workloads where all 64 ports send to one, four, eight, or sixteen destination ports, and focus on the uncontrolled startup phase where trimming is required, before receiver pull-pacing kicks in. The results are shown in Figures 5. The incast senders start at time 0 and all figures show the CDF of header (trimmed packet) arrival times at the receiver.

Figure 5a shows header arrival times for a 64 to 1 incast. The DoD-only implementation of Tofino works similarly to our complete mechanism, because they both rely on ingress pipeline trimming based on meters. Trimming ensures that each pipeline outputs 100Gbps towards the target port, so a third of these packets are still deflected on drop; these will experience higher latency due to the serialization and recirculation delay. As the incast is short lived, the effects of these recirculated packets is small.

Mirror-on-Drop performs worst in this case as it always adds a delay of around 1us to all headers because of the recirculation latency. For short-lived incasts, retransmissions triggered by these headers will arrive 1us later and can lead to link under-utilization. To avoid such cases, we need to add 1us (9 packets) extra buffering to each port, increasing buffering to 20 packets from the suggested 10 [5].

Figure 5c shows another extreme where the 64 senders send to 16 receivers, creating sixteen parallel 4-to-1 incasts. This is the worst case scenario described in Section 3, where the senders to the same receiver are spread across different pipes. In this case, fixed ingress meters (the “DoD” curve) do

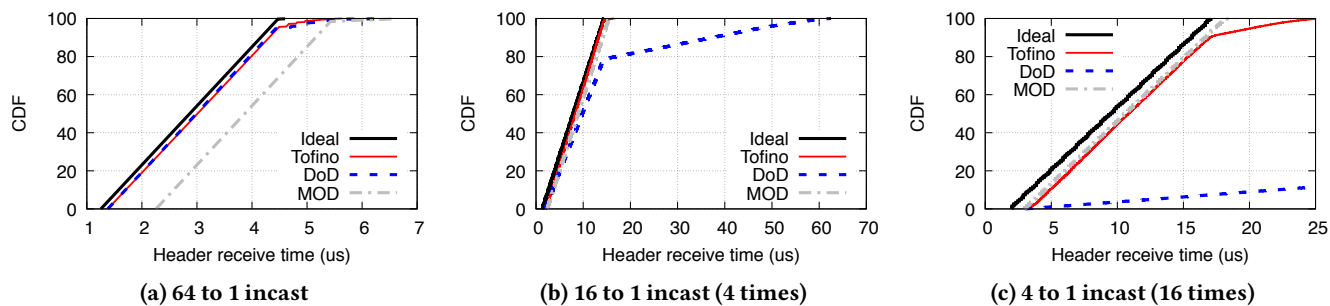

Figure 5: Comparison between different ways of implementing trimming.

not reduce the load, and each pipe has an excess of 1.2Tbps of traffic arriving that should be trimmed. This overloads the 100Gb/s recirculation port and results in a huge latency for these headers; this mechanism is unstable in this setup.

MoD works well in this case, its only downside being the 1us latency we already discussed. The congestion feedback we implemented helps the Tofino behave similarly to MoD-capable switches; however, some packets are still Deflected-on-Drop and the resulting headers experience higher latency (90% percentile and higher in the CDF).

Figure 5b shows behaviour in between these extremes: we have 16 to 1 incasts (4 in parallel), with 4 senders in each pipeline. In this case, we have a lot of ingress trimming and 300Gbps of excess traffic per pipe; the two modes in the DoD curve show ingress trimming (first part) and DoD trimming (second, lower slope). The adaptive ingress trimming in our full solution closely tracks the ideal. It is slightly faster than MoD because of this ingress trimming; the feedback ensures that few packets are sent through the DoD mechanism, reducing latency.

In summary, Mirror-on-Drop works well but adds a fixed latency which requires slightly larger buffers; trimming solutions based on this have been implemented by other groups and tested on Broadcom Trident 4 and NVidia Spectrum 2 switches [10], and we do not explore this mechanism further here.

Ingress trimming is closest to ideal as long each meter sees enough of the traffic load; Deflect-on-Drop adds large latency to headers and can only cope with limited overload. Ingress trimming coupled with our control loop tracks Ideal quite closely in these experiments.

As this mechanism is quite involved, we focus the rest of this evaluation to show that it is robust and works in all conditions, as well as explaining how we chose its parameters.

## 6.2 Base evaluation: Ideal versus Tofino

To understand macroscopic behaviour of our Tofino implementation, we now compare the average throughput obtained, the fairness, as well the number of packets trimmed by each

switch when we vary the number of senders from 1 to 64. In each experiment, sender  $i$  connects the ingress port  $i$  of the switch and sends traffic to a receiver connected to the output port  $i\%16$  of the switch. With 64 senders this corresponds to the worst case scenario for the Tofino switch where each DoD queue has an overflow ratio of 12 to 1; however, values smaller than 64 are also interesting to explore because they create traffic imbalance across pipes where fairness could be affected by the wrong congestion response mechanism.

Each sender opens one NDP connection to the receiver; when multiple receivers are connected to the same port, they share the same pull pacer which allows NDP to regulate the rate of incoming packets after the initial sender-controlled part of the connection. This initial phase is the most difficult one for the switch because pull pacing is not in effect yet, and packets arrive at line rate from the senders; to amplify its effects we use a large initial window for NDP of 1000 packets; this means that our senders will send at line rate for the first 125 microseconds; we run our experiment for 500 microseconds in total.

When the switch dequeues a packet from the DoD queue for an outgoing port, it sends congestion notifications to all pipelines at once, instructing them to go into pessimistic mode for that port for 6 microseconds (the time to drain 64 packets). After that, the switch goes into semi-pessimistic mode for another 18 microseconds. The latency of packet recirculation is set to 1us.

We plot the average throughput obtained by the flows in the experiment in figure 6.a. The goodput obtained by the Tofino implementation of NDP is within 5% of the ideal NDP behaviour. Figure 6.b shows that the Tofino trims at most 10% more packets than the ideal switch (6% more on average across all experiments). This is expected, since the congestion mechanism is coarser grained than the ideal switch implementation where packets are only trimmed when the queue is full. Still, the results below show that our congestion mechanism manages to keep the DoD queues low; across all experiments, the maximum DoD queue size did not exceed 250 packets.

To better understand the results, we now focus on a few



# Implementing packet trimming support in hardware

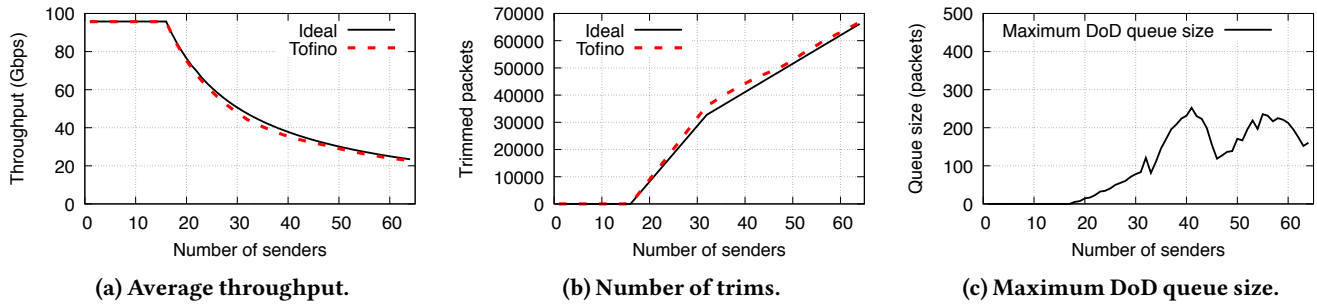

Figure 6: Comparison between Tofino and Ideal Switch implementations.

specific experiments, where we fix the number of senders and take a closer look at how the congestion mechanisms come into effect.

The smallest number of senders that trigger a buildup of the DoD queue is 18 senders where senders 1 to 16 send to output ports 1 to 16, sender 17 to port 1 and 18 to 2. In this case, total traffic to ports 1 and 2 is 200Gbps each; 200Gbps from pipeline 1 and 200Gbps from pipeline 2. A little less than half of this traffic enters the output port, and half is directed to the DoD queue, trimmed and then makes it to the output port. The arrival rate of each DoD queue in pipelines 1 and 2 is a little over 100Gbps, thus a queue builds and the congestion mechanism kicks in. Note that with 17 senders, the rate of traffic arriving in the DoD queue is just 50Gbps, so a queue never builds, and our congestion mechanism is not triggered; with less than 17 senders, no traffic is dropped.

We plot the congestion mechanism at work in the 18 sender case in Figure 7.a. The X axis shows time since the beginning of the experiment, where 18 senders start blasting 1000 1.5KB packets each before waiting for feedback from the receiver. The Y axis shows the destination port; horizontal lines show periods where pessimistic mode is enabled for the specified target port, on all pipelines. Note that, after a pessimistic period ends, there is a halfmistic period that kicks in that lasts for 24us (not shown).

The graph shows that congestion mode kicks in periodically for ports 1 and 2 (where congestion occurs); less than a fourth of the time traffic is trimmed to 25Gbps, and most of the remainder it is trimmed to half, and the remainder there is no trimming in the ingress pipeline which triggers pessimistic mode again. The resulting flow rates are 95.7Gbps for senders 3-16, and 46-47Gbps for senders 1,2,16 and 17; this is within 1% of optimal behaviour.

We also plot below the congestion behaviour for 32 and 64 senders respectively. For 32 senders, pessimistic mode is active for all ports periodically, roughly a quarter of the time; half pessimistic mode for the remainder; flow throughput is 45-46Gbps, near-optimal.

Finally, with 64 senders, the worst case from an overload

point of view, pessimistic trimming is active for the entire duration of the incast, and flow bandwidth are fairly distributed (22.2Gbps to 23.4Gbps) and within 1% of the optimal.

## 6.3 Sensitivity analysis

The experiments so far were run with 6us pessimistic mode followed by 18us halfmistic mode. How do results vary when changing the congestion response duration? More generally, how do each of our design decisions affect the trimming behaviour. We answer these questions here.

First, we vary the congestion response from 0us (no response) to 30us (the time needed to serialize 250 packets of 1500B) and examine the number of trimmed packets compared to an ideal implementation, the average throughput obtained as well as the maximum DoD queue size, shown in Figure 8.c.

The maximum DoD queue size grows to almost 14000 packets when no congestion response occurs (the point for 0us on the X axis in the plot); this is because in each pipeline the first 16000 packets arrive at line rate (1000 per ingress port), and roughly a quarter will make it to the egress queue, while the others are deflected to the DoD queue corresponding to the ingress pipeline. To enable the DoD queue to drain by X packets, it should receive no packets for the duration it takes to serialize X packets at 100Gbps. Thus, all the ingress pipelines should go into pessimistic mode for a duration at least as large.

In the worst case scenario with 64 senders, in each RTT 48 packets will be deflected on drop, roughly 12 to each DoD queue: 1.44us is therefore the minimum duration for the congestion response to have an effect. Experiments show that at least 3us (~30 packets time) are needed to control the DoD queue size properly; this is because packets for different ports may be ordered randomly in the DoD queue, and the congestion response may focus only on one output port for a short period of time, while allowing all other output ports to pump packets in the DoD queue. In other words, the congestion response should be long enough to ensure that it bridges the gaps in the DoD queue between packets for the same output port.

The queue size results show that any congestion duration above 3us manages to keep the queue size small; how about

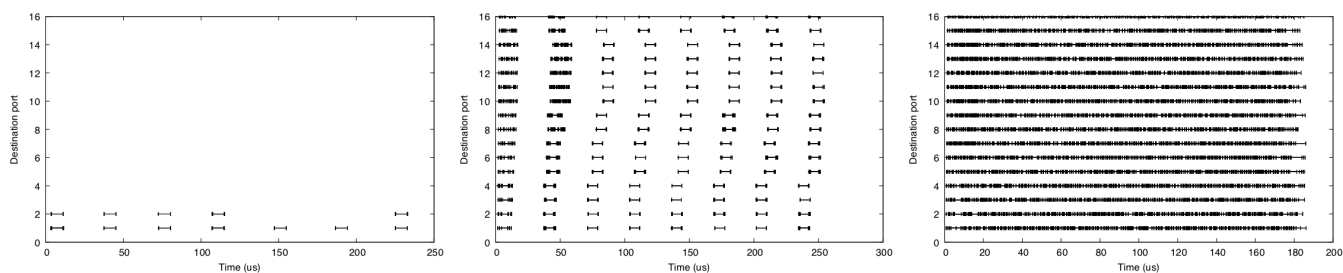

(a) Congestion response for 18 senders. (b) Congestion response for 32 senders (c) Congestion response for 64 senders  
**Figure 7: Congestion response: pessimistic mode activation, per port, as a function of time.**

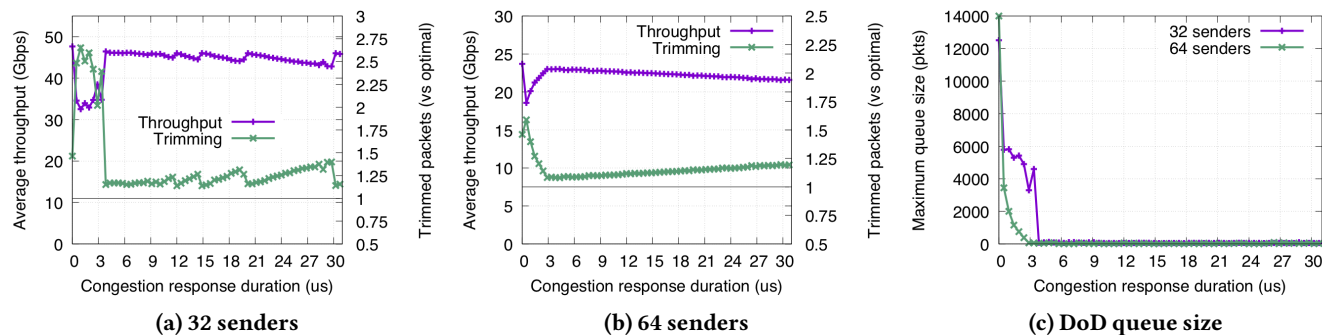

(a) 32 senders (b) 64 senders (c) DoD queue size  
**Figure 8: Effect of congestion response duration on switch behaviour**

throughput and trimmed packets? The results are shown in Figures 8.a-b. First, note that disabling the congestion response means that the average throughput is near optimal, at the cost of delayed congestion information and inflated short flow completion times. When the congestion response is enabled but its duration is less than 3us, the DoD queue size grows large and the congestion response kicks in eventually; in this case, the switch ends up trimming a lot more packets than it should, hurting throughput. Beyond 3us, there is a wide range of values that work well. However, the longer the congestion response, the bigger the effect on throughput and other traffic following the incast. That is why we chose 6us for our implementation. With these values, the number of trimmed packets is just 10% more than optimal.

**Do we need a half-timistic mode?** In our initial design, we only used a single 25% pessimistic response to congestion; this worked well for the worst case scenario with 64 senders, but less so when congestion was less severe, for instance when there were only 32 senders. In such cases, the on/off congestion response (fundamental to the experiment, which was using 25% trimming periodically to reach a 50% trimming average) resulted in DoD queue oscillations and the need for a large congestion response duration to ensure stability.

Figure 9 shows what happens with alternative trimming approaches, with 32 senders. In 9.a we use pessimistic mode alone, without a halftimistic mode following it: this means

that the ingress pipeline goes from 25% trimming to no trimming directly, instead of first trimming at 50% for a period of time. First, note that the results for 64 senders are quite similar (not shown), since pessimistic mode is active for the duration of the experiment, and a congestion response of 3us suffices also in this setup.

For 32 senders, the results are quite different: the DoD queue is unstable until the congestion response duration exceeds 14us, and this results in an average throughput of 42Gbps compared to 46Gbps for the case when half pessimistic mode is used too.

Why not trim all packets, then, instead of a fraction of packets? Trimming all packets has the benefit of allowing the DoD queue AND the output port queue to drain, so it is a tougher congestion response. We run the same experiment and plot the results in Figure 9.c. The results show at least 12us are required to have stable behaviour, while the trimming rate is 80% higher than optimal, compared to 15% in our final implementation. Throughput also suffers, with a maximum throughput of 38Gbps compared to 46Gbps. With 64 senders, the minimum response that gives stable behaviours is 10us, and the average throughput is 19Gbps compared to 23Gbps in our solution.

**Why not inform a single pipeline?** In our final what-if scenario, we explore what happens when the congestion signal is sent only to the pipeline that originated the DoD packet. The congestion response is pessimistic mode followed by half-pessimistic mode, but only for that pipeline. The results show

# Implementing packet trimming support in hardware

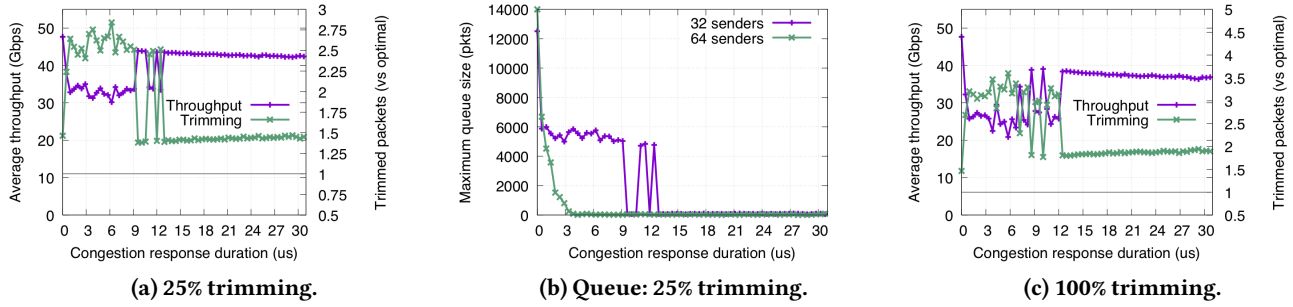

Figure 9: Queue oscillations appear with 32 senders with more aggressive trimming

that, for both 32 and 64 senders, we now need a congestion response duration of at least 9-12us for the DoD queues to remain small; nevertheless, the number of trimmed packets is 10%-15% larger than in our solution, and 20-25% more than the ideal implementation.

## 6.4 Tofino evaluation

Most of the evaluation in this paper uses simulation. Simulation allows us to precisely start flows at exact times, compare different algorithms with idealized trimming, and perform fine-grain instrumentation of our feedback loops. In the end, even though the algorithm is the same, what we really want to see is how trimming performs in real hardware.

To generate controlled 100Gb/s flows we use a second Tofino switch (“generator”) to generate flows, as in Figure 10. The trimmer switch runs our `ndp.p4` implementation. Four flows shown in red are sent from the generator to host H1 and four shown in green go to H2, resulting in a persistent high trimming rate. Such trimming would be transient with an end-to-end control loop such as NDP that kicks in after the first RTT, but the purpose here is to stress-test the switch. We verified that in this scenario no packets are lost - every packet is either delivered completely or its header arrives at the receiver.

Figure 11 shows the throughput of the four flows arriving at H1 during the startup phase as each flow arrives. The sharing is almost perfect with no unexpected startup transients. For comparison, 11b shows the same setup running in our simulator, demonstrating that the simulated behavior closely matches that of the real hardware.

We modified our `ndp.p4` implementation to mark packets that were ingress trimmed differently from those that were DoD-trimmed. We record traces of 20k packets during a 4:1 incast resulting both from the simulator and from the hardware Tofino switch. The table below shows the same number of trims happens, though more of them were DoD trims in the simulator than in the Tofino. This difference is likely due to differences in flow startup timing. As expected, most trims happen in the ingress trimmer.

Figure 12 shows packets from the first flow arriving at H1

Implementation	Ingress trims	DoD trims
Simulator	13.49K	682
Tofino	13.5k	678

when the second flow to H1 starts at  $t=0$ . The figure plots sequence number against measured arrival time at H1. The arrival times are rather bursty due to DPDK batching at H1, which is needed to keep up with the arriving 100Gb/s stream. From  $t=0$  until  $4.7\mu s$  we can see data packets arriving, but the gradient is below the trend line as a queue is building in the switch. At  $4.7\mu s$ , the queue overflows and a number of packets enter the DoD pipeline. The congestion feedback then kicks in, and at  $6\mu s$  the first ingress-trimmed packet arrives. All the early ingress-trimmed packets jump the data packet queue in the switch, arriving significantly ahead of untrimmed data packets sent around the same time. These low latency trimmed packets are very useful for NDP’s control loop. Finally, by  $10\mu s$ , the switch queue has largely drained and the network latency is very low again – half the packets are trimmed (the demand is 200Gb/s into a 100Gb/s port), but there is no significant queue left to jump, so they arrive with similar latency to untrimmed data packets.

## 6.5 End-to-end experiments

To round up our evaluation, we now present results from application workloads we have run on our leaf-spine testbed that highlight the benefits of packet trimming over conventional tail-drop or ECN-based switches. All the links in our testbed are set to 25Gbps to ensure we do not measure host overheads which would pollute the results at 100Gbps speeds. We compare the vanilla setup, with kernel Linux hosts and tail-drop switches, to the Tofino setup where trimming is implemented in all switches, and our hosts run the EQDS stack [10].

The key advantage of trimming is its ability to use small packet buffers while allowing host stacks to react quickly to overload and to cope with reordering.

The bisection bandwidth of our network is 75Gbps (three spines) and as a first test we run three parallel connections between two racks. In the vanilla setup, frequently flows are mapped by ECMP onto the same spine, halving the achieved

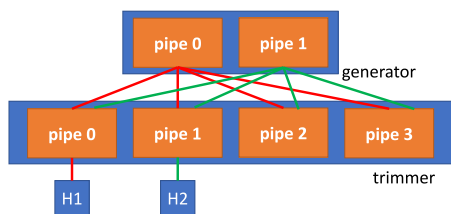
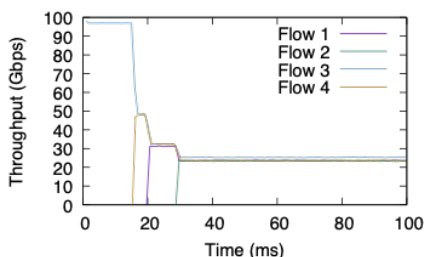
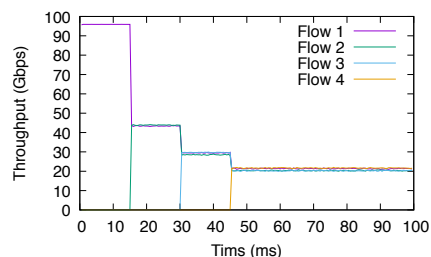

Figure 10: Tofino validation experimental setup



(a) Tofino ndp.p4 implementation



(b) Simulated Tofino algorithm

Figure 11: Throughput of the Tofino implementation with DoD

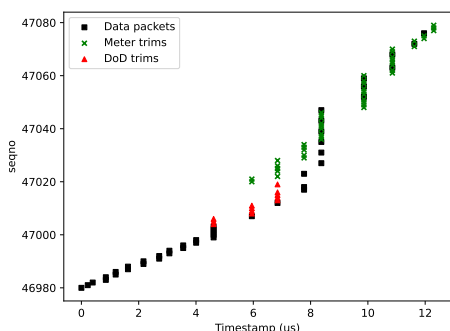

Figure 12: Trimming in Tofino

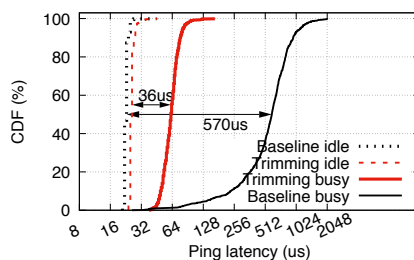

Figure 13: Faster pings with trimming

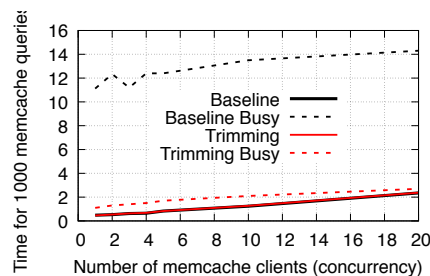

Figure 14: Memcached with trimming

bandwidth. With trimming, the end-hosts can do packet-level load balancing and all flows reach 25Gbps constantly.

In our next experiments, we explore the benefits of small switch buffers to latency-sensitive applications. Our first experiment is simple: we ping a destination machine when it is idle, and when it has nine other TCP connections sending to it from separate machines, plotting the measured ping-times in Figure 13. Note that the baseline implementation, despite having only a 200-packet buffer (fairly low for TCP standards), adds a 1/2ms delay to the latency sensitive traffic when the network is busy. With trimming, we can configure the switch buffer to be much lower (just 12 packets), which causes a much smaller latency increase of just 36us.

Finally, we install memcached on one target machine and use a benchmarking tool called memcslap to test its performance; the benchmark consists of issues 1000 memcache requests in a closed loop for each emulated client. We run the experiment both when the target machine is idle, and when it is busy with a long lived TCP incast which will fill the ToR switch buffer corresponding to the destination host.

Figure 14 shows the total time needed to run the memcslap benchmark; when the destination is idel, it takes between one to two seconds depending on the number of emulated clients. When the destination is busy, however, the baseline time jumps more than ten times; in contrast, trimming enables keeping queue sizes small and the increase is much smaller.

## 7 CONCLUSIONS

Although current programmable switches were not specifically designed with packet trimming in mind, they are sufficiently flexible that it is now possible to implement and deploy trimming in today’s datacenters that deploy such switches. The main benefits of trimming occur when implemented in top-of-rack switches which are most likely to support such programmability.

Key to enabling trimming is the ability to deflect packets that would have been dropped into a recirculation port. On Tofino we have demonstrated that even though the deflect-on-drop bandwidth is limited, combining this with P4-based trimming in the ingress pipelines using meters enables a low-latency trimming solution that closely mirrors idealized trimming. Switches such as Tofino 2 that allow the ingress pipeline to read the downstream queue size, or switches that allow mirroring just the header to a recirculation pipeline can also effectively implement trimming.

For minimum feedback latency, ideally most trimming will occur in the ingress pipeline without the headers being recirculated, as in our Tofino implementation. When some trimming is done via recirculation and some in ingress, header reordering will occur. The great advantage of trimming, though, is that reordering need not be mistaken for loss. Indeed, protocols such as NDP or EQDS designed with packet spraying and trimming in mind have no problem with such reordering.

# Implementing packet trimming support in hardware

, ,

## REFERENCES

- [1] Mohammad Alizadeh, Albert Greenberg, David A. Maltz, Jitendra Padhye, Parveen Patel, Balaji Prabhakar, Sudipta Sengupta, and Murari Sridharan. “Data Center TCP (DCTCP)”. In: *Special Interest Group on Data Communication (SIGCOMM)*. ACM, 2010.
- [2] Peng Cheng, Fengyuan Ren, Ran Shu, and Chuang Lin. “Catch the Whole Lot in an Action: Rapid Precise Packet Loss Notification in Data Centers”. In: *NSDI’14*. USENIX Association, 2014, pp. 17–28.
- [3] Advait Dixit, Pawan Prokash, Charlie Y. Hu, and Ramona R Kompella. “On the Impact of Packet Spraying in Data Center Networks”. In: *International Conference on Computer Communications (INFOCOM)*. IEEE, 2013.
- [4] Mohammad Al-Fares, Sivasankar Radhakrishnan, Barath Raghavan, Nelson Huang, and Amin Vahdat. “Hedera: Dynamic Flow Scheduling for Data Center Networks”. In: *Networked Systems Design and Implementation (NSDI)*. USENIX Association, 2010.
- [5] Mark Handley, Costin Raiciu, Alexandru Agache, Andrei Voinescu, Andrew W. Moore, Gianni Antichi, and Marcin Wójcik. “Re-architecting Datacenter Networks and Stacks for Low Latency and High Performance”. In: *Special Interest Group on Data Communication (SIGCOMM)*. ACM, 2017.
- [6] Shuihai Hu, Wei Bai, Gaoxiong Zeng, Zilong Wang, Baochen Qiao, Kai Chen, Kun Tan, and Yi Wang. “Aeolus: A Building Block for Proactive Transport in Datacenters”. In: *SIGCOMM ’20*. Association for Computing Machinery, 2020, pp. 422–434.
- [7] Jeongkeun Lee. *Advanced Congestion and Flow Control with Programmable Switches*. 2020. URL: <https://opennetworking.org/wp-content/uploads/2020/04/JK-Lee-Slide-Deck.pdf>.
- [8] Jeongkeun Lee, Jeremias Blendin, Yanfang Le, Grzegorz Jereczek, Ashutosh Agrawal, and Rong Pan. *Source Priority Flow Control (SPFC) towards Source Flow Control (SFC)*. IETF 112, ICCRG Working Group Presentation. 2021. URL: <https://datatracker.ietf.org/meeting/112/materials/slides-112-iccr-g-source-priority-flow-control-in-data-centers-00>.
- [9] Behnam Montazeri, Yilong Li, Mohammad Alizadeh, and John Ousterhout. “Homa: A Receiver-driven Low-latency Transport Protocol Using Network Priorities”. In: *Special Interest Group on Data Communication (SIGCOMM)*. ACM, 2018.
- [10] Vladimir Olteanu, Haggai Eran, Dragos Dumitrescu, Adrian Popa, Cristi Baciuc, Mark Silberstein, Georgios Nikolaidis, Mark Handley, and Costin Raiciu. “An edge-queued datagram service for all datacenter traffic”. In: *19th USENIX Symposium on Networked Systems Design and Implementation (NSDI 22)*. USENIX Association, Apr. 2022, pp. 761–777.
- [11] Costin Raiciu, Sebastien Barre, Christopher Pluntke, Adam Greenhalgh, Damon Wischik, and Mark Handley. “Improving Datacenter Performance and Robustness with Multipath TCP”. In: *Special Interest Group on Data Communication (SIGCOMM)*. ACM, 2010.
- [12] Vijay Vasudevan, Amar Phanishayee, Hiral Shah, Elie Krevat, David G. Andersen, Gregory R. Ganger, Garth A. Gibson, and Brian Mueller. “Safe and Effective Fine-Grained TCP Retransmissions for Datacenter Communication”. In: *SIGCOMM ’09*. Association for Computing Machinery, 2009, pp. 303–314.
- [13] Yibo Zhu, Haggai Eran, Daniel Firestone, Chuanxiong Guo, Marina Lipshteyn, Yehonatan Liron, Jitendra Padhye, Shachar Raindel, Mohamad Haj Yahia, and Ming Zhang. “Congestion Control for Large-Scale RDMA Deployments”. In: *SIGCOMM ’15*. Association for Computing Machinery, 2015, pp. 523–536.