

Federated Semi-Supervised Classification of Multimedia Flows for 3D Networks

Saira Bano^{*†}, Achilles Machumilane^{*†}, Lorenzo Valerio[‡], Pietro Cassarà[†], Alberto Gotta[†]

^{*}Department of Information Engineering, University of Pisa, Pisa, Italy

[‡]CNR, Institute of Informatics and Telematics, Pisa, Italy

[†]CNR, Institute of Information Science and Technologies, Pisa, Italy

Abstract—Automatic traffic classification is increasingly becoming important in traffic engineering, as the current trend of encrypting transport information (e.g., behind HTTP-encrypted tunnels) prevents intermediate nodes from accessing end-to-end packet headers. However, this information is crucial for traffic shaping, network slicing, and Quality of Service (QoS) management, for preventing network intrusion, and for anomaly detection. 3D networks offer multiple routes that can guarantee different levels of QoS. Therefore, service classification and separation are essential to guarantee the required QoS level to each traffic sub-flow through the appropriate network trunk. In this paper, a federated feature selection and feature reduction learning scheme is proposed to classify network traffic in a semi-supervised cooperative manner. The federated gateways of 3D network help to enhance the global knowledge of network traffic to improve the accuracy of anomaly and intrusion detection and service identification of a new traffic flow.

I. INTRODUCTION

The 3D networks are expected to exploit satellite, aerial and terrestrial platforms jointly [1] for improving the radio access in future 6G networks to support the well-known 5G classes of service, i.e., enhanced Mobile Broadband (eMBB), Ultra-Reliable Low Latency Communications (URLLC), massive Machine Type Communications (mMTC), as well as tactile Internet and virtual reality applications [2]. However, these 3D networks pose a challenge to the different levels of Quality of Service (QoS) requirements that each network technology can provide. For instance, while the satellite link can provide bandwidth required for an eMBB-type service, it is not guaranteed that it can satisfy the latency constraints expected in 5G for URLLC traffic [3]. Therefore, service classification and separation are of utmost importance to guarantee the required QoS level to a given traffic flow through the suitable network trunk. Moreover, different access technologies (satellite, aerial or terrestrial) may use data protection techniques [4]–[6], which may not be suitable for every class of traffic, which introduces in some cases, severe delays or jitter, not matching service class requirements.

Traffic characterization depends on the information found in the client-server data streams. The availability of such information depends on the communication protocols used and the modality with which the data streams are examined [7], i.e., data processing techniques play an important role in information retrieval. If the traffic is not encrypted, it is usually possible to perform a complete analysis. In such a

scenario, the packet content can be inspected by accessing the packet header and the payload called Deep Packet Inspection (DPI). Accessing transport protocol information allows header compression/suppression when capacity is scarce, adapt the protocol behaviour to the characteristics of the network bottlenecks (e.g. HTTP acceleration or split-connections), and implement multi-class per-hop behaviour in the absence of another IP signalling. Therefore, a solution is needed to avert losing these benefits when encrypting transport headers [8] or other HTTP tunnels will be prevalent. Traditional methods of traffic analysis were based on DPI [9], which refers to a set of analysis tools aimed at extracting information from the headers, payload and classifying the flows. However, with the increasing number of new applications, which no longer have fixed port numbers that can be queried but adopt random port strategies, the accuracy of DPI are gradually declining. Moreover, since the advent of the encrypted transport headers, as in QUIC traffic [10] (an encrypted transport protocol proposed by Google), the range of applicability of DPI has been progressively fading out, paving way for new form of blind data extraction. Machine Learning (ML) is also gaining popularity in many communication, and networking scenarios [11], [12] and recently, in solving traffic classification problems as a viable substitute for DPI. ML algorithms can be classified into three families: *Supervised*, *Unsupervised* and *Semi-supervised*. The first family requires labelled training dataset; the second one discover hidden patterns within the dataset without labels; the last one uses a small amount of labelled data and a large amount of unlabelled data during training.

Semi-supervised methods are particularly attractive when the goal is to reduce the cost of obtaining the labelled data. The goal is to retrieve knowledge about the missing labels by evaluating the similarity between unlabeled and labelled data. They typically define data inspection tasks or optimised manual labelling of the unlabeled data to provide adequate information. Even though the semi-supervised techniques do not require a fully labelled data set, the effort required to label some data at the beginning of the training phase can be time consuming. To reduce the computational cost of the semi-supervised techniques, dimension reduction methods and federated learning protocols can be used. In the first case, feature selection can be used to reduce the computational and

communication costs compared to the elaboration of the native dataset. In the second case, federation allows some of the computational operations to be offloaded to the edge gateways, reducing the computational load for a central server and the number of control messages exchanged.

In this paper, we provide the following contributions:

- a federated semi-supervised regression algorithm based on Neural Network suitable for resource constrained devices
- a federated dimensionality reduction procedure based on an information-based feature selection
- a comparison of selected state of the art feature selection schemes
- a numerical analysis of the performance obtained by using both centralized and federated versions of the regression algorithm

The rest of the paper is organized as follows. In Section II, the related work is presented. Section III presents the general methodology and description of the scenario. The performance evaluation is shown in Section IV and Section V concludes the paper.

II. RELATED WORK

Internet traffic classification using supervised, unsupervised, and semi-supervised learning has been widely investigated in literature [7] and several solutions have been studied for traffic monitoring and analysis applications. These methods differ in the way they extract features x_i , for traffic analysis i.e., the variables that allow outputting the classification y . Traffic analysis methods fall into three main classes: *Statistics-based methods*, *Correlation-based methods*, and *Fingerprint-based methods*.

1) *Statistics-based methods*: are based on the representation of traffic flows by statistical features at the traffic flow level, which are used to capture the characteristic patterns of a traffic flow. These features are: statistical metrics related to the number of packets transmitted, the number of bytes transmitted, the time between the arrival of packets, and the packet size of a flow. In [13], 23, metrics such as maximum length (bytes), minimum length, mean, median, standard deviation, and cumulative length are applied to five objects: Total packets, Forward packets, Backward packets, Handshake packets, and Data transfer packets. In [14], the statistical features are extracted from a vector of packet lengths, considering three sets of packets: incoming, outgoing, and bidirectional flow packets. In [15], the selected features are: Protocol, Source Port Number, and Destination Port Number, which are referred to as classical features; instead, maximum, minimum, mean, and variance of packet size are referred to as statistical features.

2) *Correlation-based methods*: are characterized by incorporating knowledge about the correlation between flows to accomplish the classification task. These methods are often based on the so-called Bag-of-Flows (BoF), which groups the correlated flows according to a set of heuristics such as the

destination IP address, the destination port, and the transport protocol [16]–[18].

3) *Fingerprint-based methods*: are based on extracting a fingerprint, i.e., a vector or function, possibly a probability density function, capable of summarizing the main characteristics common to a specific traffic class. Fingerprinting requires a significant amount of data per class to be identified. In [19], traffic fingerprinting is used to classify IP flows produced by network applications exchanging data through TCP connections such as HTTP, SMTP, SSH by looking at client-server or server-client flows. A vector of Probability Density Functions (PDF) is estimated from a training set of flows generated by the same protocol to build the protocol fingerprints.

In recent years, the proliferation of encrypted traffic has led to an increase of *flow-based methods* that rely on the analysis of statistical or time-serial features using ML. These include Naive Bayes (NB), Support Vector Machine (SVM), Random Forest (RF), and K-Nearest Neighbours (KNN) [20], [21]. However, the most tedious task in building a ML model for traffic classification is labelling the data, which requires human intervention, so it is advantageous to use a semi-supervised approach.

In [22], the classifier can detect several classes of services with encrypted traffic with reasonable accuracy. While the initial analysis considers 1400 features, it turns out that these features can be reduced to only three by feature reduction.

III. PROBLEM DEFINITION AND METHODOLOGY

The task we address in this paper is to estimate the percentage of traffic of a particular protocol or class of applications within a data stream that contains many types of traffic. We have applied the regression techniques in [23] to an edge computing scenario where edge gateways are resource constrained. In this reference scenario, model training is distributed, i.e., each edge gateway trains the model using its own locally collected traffic. Then, a centralized edge server merges the knowledge obtained from each end gateway and distributes the merged model to all federated end gateways. For this purpose, we developed a regression algorithm based on a neural network (NN) and combined the regression algorithm with a feature selection technique that is also used in the federation. We then analyzed the accuracy of the federated regression model compared to the centralized model and investigated how feature selection affects model accuracy as well as computational and communication load during model training. In the following sections, we elaborate on the scheme we developed.

A. Regression Algorithm

The regression algorithm developed in this work is based on a Neural Network (NN) with a single hidden layer and uses the ADAM optimizer [24], an efficient version of Stochastic Gradient Descent (SGD). Unlike SGD, however, ADAM computes individual adaptive learning rates for different parameters from estimates of the first and second moments of the gradients,

making it suitable for non-convex optimization problems, even when running on constrained devices, since it is computationally efficient.

Figure 1 shows the steps of the proposed procedure; precisely, Fig. 1a shows the steps performed at the edge server and Fig. 1b shows the steps performed at the edge gateways.

Step₀ The edge server trains the initial regression model in a supervised way using a pre-elaborated dataset, and propagates the trained model to the edge gateways. **Step₁** Each edge gateway acquires unlabelled local data and performs soft data labelling by using the global model.

Step₂ Each edge gateway uses its soft labels to perform feature selection, and sends the Probability Mass Function (PMF) of the selected features to edge server.

Step₃ The edge server aggregates all these selected features PMF, and send it back to the edge gateways the federated feature selection scheme.

Step₄ Each edge gateways trains its local models using the restricted set of features evaluated through the federated scheme. The trained model is then transmitted toward the edge server for the federation

Step₅ The edge server averages the received models from edge gateways and merges this averaged model with the global regression model available. The edge server propagates the new global regression model toward the edge gateways.

The process continues from **Step₁** until a desired accuracy is achieved. The following section explains in detail the feature selection algorithm.

B. Feature Selection Algorithm

The Feature Selection (FS) algorithm used in this paper is developed in both centralised and federated fashion, inspired by [25], and can be formulated as follows:

Definition (FS Problem). *Given the input data matrix \mathbf{X} composed by n samples of m features ($\mathbf{X} \in \mathbb{R}^{n \times m}$), and the target labels' vector $\mathbf{y} \in \mathbb{R}^n$, the feature selection problem is to find a k -dimensional subset $\mathbf{K} \subseteq \mathbf{X}$ with $k \leq m$, by which we can characterize \mathbf{y} .*

The algorithm used in this work is based on the measure of Mutual Information (MI) that measures the amount of information obtained about the class label through the set of selected features. The MI is related to the entropy $\mathbf{H}(\cdot)$ that measures the uncertainty of a random variable, as shown in the following equation [26], [27].

$$\mathbf{I}(\mathbf{U}; \mathbf{y}) = \mathbf{H}(\mathbf{y}) - \mathbf{H}(\mathbf{y}|\mathbf{U}), \quad (1)$$

In the previous equation $\mathbf{U} = \{\mathbf{x}_1 \cdots \mathbf{x}_k \mid k \leq m\} \subseteq \mathbf{X}$ is the subset of selected features, and $\mathbf{H}(\mathbf{y}|\mathbf{U})$ is the conditional entropy that measures the amount of information needed to describe \mathbf{y} , conditioned by the information carried by \mathbf{U} . In brief, the $\mathbf{I}(\mathbf{U}; \mathbf{y})$ represents the dependence between \mathbf{U} and \mathbf{y} , i.e., the greater is the value \mathbf{I} , the greater is the information carried by \mathbf{U} on \mathbf{y} . The features selected in \mathbf{U} , also known as Essential Attributes (EAs), provide the maximum value for equation (1).

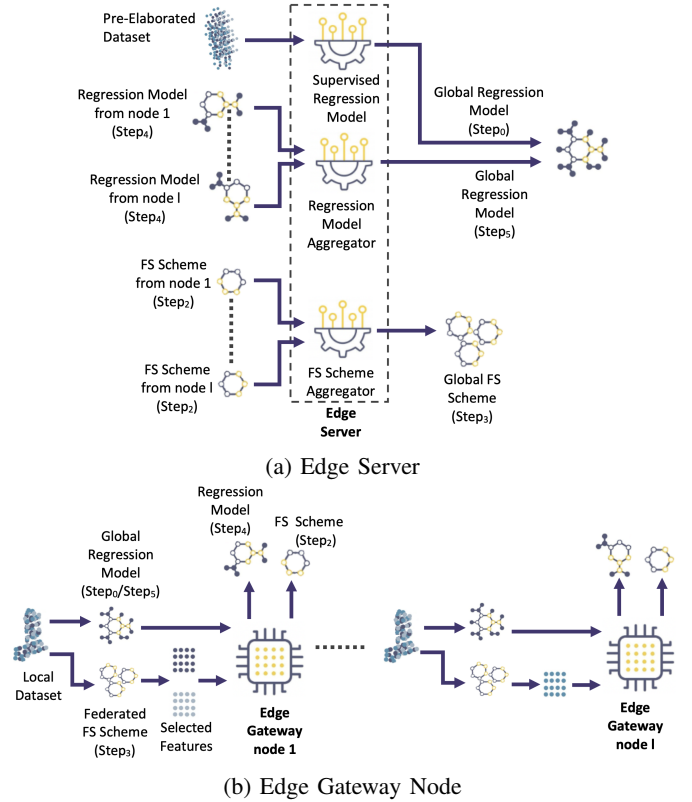

Fig. 1: Federated learning edge architecture

In [26], [27] authors prove that the feature selection problem can be solved as an optimization problem as given in equation (2),

$$\arg \max_{\mathbf{U}} \mathbf{I}(\mathbf{U}; \mathbf{y}) \quad (2)$$

$$\mathbf{U} = \{\mathbf{x}_1 \cdots \mathbf{x}_k \mid k \leq m\} \subseteq \mathbf{X}$$

by assuming independent features. They also provide the incremental version of the previous algorithm, as shown in equation (3).

$$\arg \max_{\mathbf{x}_j \in \mathbf{X} \setminus \mathbf{U}} \mathbf{I}(\mathbf{x}_j; \mathbf{y}|\mathbf{U}), \quad (3)$$

$$\mathbf{U} = \{\mathbf{x}_1 \cdots \mathbf{x}_{k-1} \mid k \leq m\} \subseteq \mathbf{X}.$$

By using Cross-Entropy-based [28] feature selection algorithm, we can provide the solution to equation (2) by selecting a set of EAs at a time, instead of selecting a single feature at a time. The solution provided by the Cross-Entropy-based algorithm is the distribution probability $\mathbf{p} = [p_1, \cdots p_m]$ of selecting features in \mathbf{U} to get the maximum for the problem in equation (2).

The Federated Feature Selection (FFS) procedure adopted in this paper exploits the Bayesian's theorem to merge the local distribution probability \mathbf{p} into the global one. Formally, we assume that each node acquires several *i.i.d.* records n^l to address the optimization problem (2), and that the nodes share

the same set of features \mathbf{X} . The global probability \mathbf{p}^G used for the FS can be written as follows:

$$\mathbf{p}^G = \sum_l \mathbf{p}^l q^l, \quad (4)$$

where $\mathbf{p}^{(l)}$ is the probability distribution of selecting the features at the node l , and $q^{(l)}$ is the weight of this distribution probability. As shown in equation (5), the weight is proportional to the size of its local dataset compared to the whole amount of data present in the system. In this way, we can contrast situations where local datasets are heterogeneous w.r.t. the size.

$$q^l = \frac{n^l}{\sum_l n^l} \quad (5)$$

In the next section we provide the performance analysis of the procedure discussed in this section.

IV. NUMERICAL ANALYSIS

The dataset used to analyse the performance of the developed semi-supervised method is the QUIC traffic dataset [29]. The dataset contains flow packets based on QUIC and non-QUIC traffic generated from five different Google services: Google Drive, Google Docs, Google Music, Google Search, and YouTube. The authors developed scripts using Selenium WebDriver and AutoIt tools to mimic human behaviour during data collection. This approach enables the acquisition of data sets with more than $20 \cdot 10^6$ records without much human effort. The records in the files contain three fields: Unix timestamp, the acquisition time and packet length

We merged all the files by synchronizing them with the Unix timestamps. This gave us a single file containing all the records for QUIC and non-QUIC traffic for the five different classes of services as mentioned above. We also developed Python-based scripts to extract the following features: Number of QUIC packets within a sampling window of size 1 second, 25-th, 50-th, 75-th, and 90-th percentiles of packet arrival time, 25-th, 50-th, 75-th, and 90-th percentiles of packet sizes. For each record of extracted features, we evaluated two class labels: *Class Label QUIC*- the percentage of QUIC-based traffic and *Class Label Service*- the percentage of traffic due to a class service within the sample window considered. We split the dataset with the extracted features into two sets: The first contains the 20% of samples used for supervised training of the regression model, as specified in the **Step₀** of the procedure. The second contains the 80% of samples distributed over a set of 10 end devices to perform the local unsupervised training of the regression model, as specified in the procedure from **Step₁** to **Step₅**.

We analyzed the performance of the proposed cross-entropy-based (CE) algorithm for feature selection from the QUIC dataset. We compared the performance of CE in detecting the proportion of QUIC traffic versus non-QUIC traffic in a sample of traffic outages with the performance of other information-based feature selection algorithms such as mRMR [30], CMIM [31], and DSR [32], which provide the solution to

the optimization problem in equation (3). We also compared the cross-entropy based algorithm with the analysis of variance technique. This technique, known as ANOVA [33], determines the variance of all features and divides them into systematic and random factors, where random factors have no effect on learning because the variance of these features is zero. The higher the F-score, the greater the variance between the means of the two populations. We assume that features with zero variance do not add information by considering the relationship between the target variable and the feature vectors. In our case, ANOVA is used to compare the mean values of the features and determine a set of features that efficiently contribute to the classification of traffic. Table I shows the results of the feature selection scheme obtained with the methods discussed above. Most feature selection methods provide a ranking of the

Feature	Features Selection Scheme				
	CE	ANOVA	CMIM	DISR	mRMR
1) \bar{N}	0	0	0	1	1
2) ΔT_{25-th}	0	1	0	0	1
3) ΔT_{50-th}	1	0	1	1	0
4) ΔT_{75-th}	0	1	0	0	0
5) ΔT_{90-th}	0	0	0	0	0
6) Ln_{25-th}	1	0	1	0	0
7) Ln_{50-th}	1	1	1	1	1
8) Ln_{75-th}	1	1	1	1	1
9) Ln_{90-th}	1	1	1	1	1

TABLE I: Extracted Features Set

features analyzed. Instead, our method automatically returns the minimum set of features, which in this case is 5 and guarantees the best estimate for the regression model. For this reason, we select the first five features of each method. Another advantage of the cross-entropy based algorithm is that we can implement a federated version. To our knowledge, this is the first federated feature selection method. Table II shows the comparison of the performance obtained with the regression model in identifying the percentage of QUIC traffic in the received data stream, taking the subsets of features selected with the various methods discussed previously. The cross-entropy and CMIM algorithms provide a performance degradation of the regression model of just under 1% w.r.t. without feature selection; instead, we obtain a degradation of almost 5% with ANOVA and almost 10% with both DSR and mRMR, compared to the performance obtained with the full set of features. While we obtain the same performance with the cross-entropy-based and CMIM algorithms, the former allows us to automatically compute the minimum number of features and can also be implemented in a federated version. In Table (III), we provide the performance analysis in terms of control traffic (measured in MBs) when both FS and the regression model are federated. More specifically, we compare the performance of the procedure used to train the regression model when this is done without model federation and feature selection, or Centralized Regression (CR), with federation of models, or Federated Regression (FR), and with federation of models trained over the selected set of features, or Restricted Federated Regression (RFR). The values in the column *Avg.*

Method	RMSE	Selected Feat. #
No Feature selection	–	0.0121 9 (All)
Centralised FS	CE	0.0122 5
	ANOVA	0.0127 top 5
	CMIM	0.0123 top 5
	DSR	0.0133 top 5
	mRMR	0.0133 top 5

TABLE II: Supervised Feature selection. Performance of regression model trained using the features selected by each method.

Procedure	Avg. Traffic (Fed./F.S.)	Conv. Rounds (Fed./F.S.)	RMSE
CR	5.8	-	0.0122
FR	0.44/-	8/-	0.0152
RFR	0.315/0.108	10/12	0.0219

TABLE III: Performance comparison among the regression procedures: centralized, federated and restricted federated.

Traffic show the volume of control traffic generated by all nodes during the learning procedure to train the regression model. Centralized regression generates the highest load because all nodes use regression model estimation using a neural network with an input layer based on all available data sets in each learning round. The federated regression involves lighter regression models than the previous one because the neural network input layer is based on a smaller data set, namely the data set available at the node. In this case, all control traffic is due to the federated method. Finally, the Restricted Federated Regression procedure generates the least control traffic, since it uses the local dataset containing only the records of the selected features. Note that in this last case 0.108 MB of the 0.315 MB control traffic is due to the federated feature selection procedure, which involves data exchange between the edge server and the end devices.

The values in the *Conv. rounds* column indicate the number of communication rounds required by the federated procedure to merge the local models into the global model. We assume that convergence for the global model is achieved when the difference between the weights of two consecutive rounds of learning is on average less than 1%. The average number of rounds of communication required for convergence is also shown during a learning round for the Restricted Federated Regression procedure.

Finally, the values in the *RMSE* column show the values of RMSE evaluated between the ground truth and the trained regression model trained with the procedures discussed so far. The lowest RMSE is obtained with centralized regression, since we use the entire dataset to feed the neural network. Note that the RMSE increases when the amount of information used as input to the neural network is reduced. Note that the degradation of the RMSE is slower than the growth of the control traffic. For example, the RMSE of the Restricted Federated Regression is $\sim 1.8\times$ the RMSE of the Centralized

Regression, but the control traffic of the Centralized Regression is more than 50 *times* the control traffic of the Restricted Federated Regression.

V. CONCLUSION

In this work, we have developed a procedure to capture the rate of QUIC traffic within a data stream using a regression model trained with a semi-supervised technique. This technique is used to intercept and separate traffic belonging to a particular protocol (e.g., QUIC) or class of service (streaming, real-time interactive, browsing, mail, etc.) in order to direct it to a desired trunk of a 3D network. To this end, multiple edge gateways are assumed to cooperate to create a common classification model to intercept and classify the destination traffic. We tested the effects of federation of regression models trained locally by a set of gateway nodes. Finally, together with the federation, we introduced a novel feature selection technique to reduce communication and computation costs. Based on the cross-entropy method, the feature selection algorithm maximizes the mutual information of the selected features and class attributes, i.e., the quote of QUIC traffic. The proposed cross-entropy algorithm was used and compared in a centralized and a federated distributed form. The selected features provide the same performance as the whole set with negligible RMSE error, while outperforming the other baselines of 5-10% in the centralized/supervised approach. In addition, cross-entropy was also tested in a federated manner and using a semi-supervised approach with local soft labeling. Such a distributed approach significantly reduced the traffic overhead required to train the regression model, but at the cost of a higher RMSE than the centralized baseline, but preserving the number of rounds of communication required to federate the models.

ACKNOWLEDGMENT

This work has been partially supported by ESA SatNEx V project contract n. 4000130962/20/NL/NL/FE, and by TEACHING H2020 projects (GA #871385).

REFERENCES

- [1] M. Bacco, P. Cassarà, M. Colucci, A. Gotta, M. Marchese, and F. Patrone, "A survey on network architectures and applications for nanosat and uav swarms," in *International Conference on Wireless and Satellite Systems*. Springer, 2017, pp. 75–85.
- [2] R. Gupta, S. Tanwar, S. Tyagi, and N. Kumar, "Tactile internet and its applications in 5g era: A comprehensive review," *International Journal of Communication Systems*, vol. 32, no. 14, p. e3981, 2019.
- [3] M. Bacco, F. Davoli, G. Giambene, A. Gotta, M. Luglio, M. Marchese, F. Patrone, and C. Roseti, "Networking challenges for non-terrestrial networks exploitation in 5g," in *2019 IEEE 2nd 5G World Forum (5GWF)*. IEEE, 2019, pp. 623–628.
- [4] N. Celandroni and A. Gotta, "Performance analysis of systematic upper layer fec codes and interleaving in land mobile satellite channels," *IEEE Transactions on Vehicular Technology*, vol. 60, no. 4, pp. 1887–1894, 2011.
- [5] A. Gotta and P. Barsocchi, "Experimental video broadcasting in dvb-rcs/s2 with land mobile satellite channel: a reliability issue," in *2008 IEEE International Workshop on Satellite and Space Communications*. IEEE, 2008, pp. 234–238.

- [6] M. Bacco, T. De Cola, G. Giambene, and A. Gotta, "Tcp-based m2m traffic via random-access satellite links: Throughput estimation," *IEEE Transactions on Aerospace and Electronic Systems*, vol. 55, no. 2, pp. 846–863, 2018.
- [7] F. Pacheco, E. Exposito, M. Gineste, C. Baudoin, and J. Aguilar, "Towards the deployment of machine learning solutions in network traffic classification: A systematic survey," *IEEE Communications Surveys Tutorials*, vol. 21, no. 2, pp. 1988–2014, 2019.
- [8] A. Dainotti, A. Pescapé, and K. C. Claffy, "Issues and future directions in traffic classification," *IEEE Network*, vol. 26, no. 1, pp. 35–40, 2012.
- [9] T. Bujlow, V. Carela-Español, and P. Barlet-Ros, "Independent comparison of popular dpi tools for traffic classification," *Computer Networks*, vol. 76, pp. 75–89, 2015.
- [10] J. Iyengar and M. Thomson, "QUIC: A UDP-Based Multiplexed and Secure Transport," RFC 9000, May 2021.
- [11] G. F. Anastasi, P. Cassarà, P. Dazzi, A. Gotta, M. Mordacchini, and A. Passarella, "A hybrid cross-entropy cognitive-based algorithm for resource allocation in cloud environments," in *2014 IEEE Eighth International Conference on Self-Adaptive and Self-Organizing Systems*, 2014, pp. 11–20.
- [12] R. Petroccia, P. Cassarà, and K. Pelekanakis, "Optimizing adaptive communications in underwater acoustic networks," in *OCEANS 2019 MTS/IEEE SEATTLE*, 2019, pp. 1–7.
- [13] Y. Zhang, S. Zhao, J. Zhang, X. Ma, and F. Huang, "Stnn: A novel tls/ssl encrypted traffic classification system based on stereo transform neural network," in *2019 IEEE 25th International Conference on Parallel and Distributed Systems (ICPADS)*. IEEE, 2019, pp. 907–910.
- [14] G. Aceto, D. Ciunzo, A. Montieri, and A. Pescapé, "Multi-classification approaches for classifying mobile app traffic," *Journal of Network and Computer Applications*, vol. 103, pp. 131–145, 2018.
- [15] D. Tong, Y. R. Qu, and V. K. Prasanna, "Accelerating decision tree based traffic classification on fpga and multicore platforms," *IEEE Transactions on Parallel and Distributed Systems*, vol. 28, no. 11, pp. 3046–3059, 2017.
- [16] D. M. Divakaran, L. Su, Y. S. Liau, and V. L. Thing, "Slic: Self-learning intelligent classifier for network traffic," *Computer Networks*, vol. 91, pp. 283–297, 2015.
- [17] Y. Wang, Y. Xiang, J. Zhang, W. Zhou, G. Wei, and L. T. Yang, "Internet traffic classification using constrained clustering," *IEEE transactions on parallel and distributed systems*, vol. 25, no. 11, pp. 2932–2943, 2013.
- [18] Y. Wang, Y. Xiang, J. Zhang, and S. Yu, "A novel semi-supervised approach for network traffic clustering," in *2011 5th International Conference on Network and System Security*. IEEE, 2011, pp. 169–175.
- [19] M. Crotti, M. Dusi, F. Gringoli, and L. Salgarelli, "Traffic classification through simple statistical fingerprinting," *ACM SIGCOMM Computer Communication Review*, vol. 37, no. 1, pp. 5–16, 2007.
- [20] F. Pacheco, E. Exposito, and M. Gineste, "A framework to classify heterogeneous internet traffic with machine learning and deep learning techniques for satellite communications," *Computer Networks*, vol. 173, pp. 107–213, 2020.
- [21] P. Velan, M. Čermák, P. Čeleda, and M. Drašar, "A survey of methods for encrypted traffic classification and analysis," *Netw.*, vol. 25, no. 5, p. 355–374, Sep. 2015.
- [22] V. Tong, H. A. Tran, S. Souihi, and A. Mellouk, "A novel quic traffic classifier based on convolutional neural networks," in *2018 IEEE Global Communications Conference (GLOBECOM)*, 2018, pp. 1–6.
- [23] M. Fernández-Delgado, M. Sirsat, E. Cernadas, S. Alawadi, S. Barro, and M. Febrero-Bande, "An extensive experimental survey of regression methods," *Neural Networks*, vol. 111, pp. 11–34, 2019.
- [24] D. P. Kingma and J. Ba, "Adam: A method for stochastic optimization," 2017.
- [25] P. Cassarà, A. Gotta, and L. Valerio, "Federated feature selection for cyber-physical systems of systems," *arXiv preprint arXiv:2109.11323*, 2021.
- [26] R. McEliece, *In The Theory of Information and Coding: A Mathematical Framework for Communication*, ser. Encyclopedia of Mathematics and Its Applications. MA, USA: Addison-Wesley Publishing Company: Reading, 1977, vol. Vol. 3.
- [27] J. Cover, T.M. Thomas, *Elements of Information Theory*. New York, NY, USA: John Wiley and Sons, Inc, 1991.
- [28] D. Rubinstein, R.Y. Kroese, *The Cross-Entropy Method: a Unified Approach to Combinatorial Optimization, Monte-Carlo Simulation, Machine Learning*. Springer, 2004.
- [29] R. Shahbaz and L. Xin, "Dataset QUIC," <http://https://drive.google.com/drive/folders/1Pvev0hJ82usPh6dWD1z7Lv8L6h3JpWhE>, 2018, [Online; accessed 30-Oct-2018].
- [30] H. Peng, F. Long, and C. Ding, "Feature selection based on mutual information criteria of max-dependency, max-relevance, and min-redundancy," *IEEE Transactions on pattern analysis and machine intelligence*, vol. 27, no. 8, pp. 1226–1238, 2005.
- [31] P. E. Meyer, C. Schretter, and G. Bontempi, "Information-theoretic feature selection in microarray data using variable complementarity," *IEEE Journal of Selected Topics in Signal Processing*, vol. 2, no. 3, pp. 261–274, 2008.
- [32] F. Fleuret, "Fast binary feature selection with conditional mutual information," *Journal of Machine learning research*, vol. 5, no. 9, 2004.
- [33] R. M. Heiberger and E. Neuwirth, "One-way anova," in *R through excel*. Springer, 2009, pp. 165–191.