

EEND-SS: Joint End-to-End Neural Speaker Diarization and Speech Separation for Flexible Number of Speakers

Yushi Ueda¹, Soumi Maiti¹, Shinji Watanabe¹,
Chunlei Zhang², Meng Yu², Shi-Xiong Zhang², Yong Xu²

¹Carnegie Mellon University, Pittsburgh, PA, USA, ²Tencent AI Lab, Bellevue, WA, USA

{yueda, smaiti, swatanab}@andrew.cmu.edu
{cleizhang, raymondmyu, auszhang, lucayongxu}@tencent.com

Abstract

In this paper, we present a novel framework that jointly performs speaker diarization, speech separation, and speaker counting. Our proposed method combines end-to-end speaker diarization and speech separation methods, namely, *End-to-End Neural Speaker Diarization with Encoder-Decoder-based Attractor calculation (EEND-EDA)* and the *Convolutional Time-domain Audio Separation Network (ConvTasNet)* as multi-tasking joint model. We also propose the multiple 1×1 convolutional layer architecture for estimating the separation masks corresponding to the number of speakers, and a post-processing technique for refining the separated speech signal with speech activity. Experiments using LibriMix dataset show that our proposed method outperforms the baselines in terms of diarization and separation performance for both fixed and flexible numbers of speakers, as well as speaker counting performance for flexible numbers of speakers. All materials will be open-sourced and reproducible in ESPnet toolkit¹.

Index Terms: speaker diarization, speech separation, end-to-end, multitask learning

1. Introduction

Speaker diarization is the task of estimating multiple speakers' speech activities ("who spoke when") from input audio [1]. On the other hand, speech separation is the task of separating each speaker from input mixture audio. Both speech separation and speaker diarization are used as key technologies for Automatic Speech Recognition where multiple speakers are present, such as meetings [2, 3] or parties [4].

Suppose that the information of "who spoke when" is known beforehand, it is expected that we could separate the overlapped speech more easily, and *vice versa*. Therefore, we can assume that the tasks are mutually related, and the result of one task benefits the performance of the other. However, in most cases, it is not possible to obtain either of the information in advance, which makes it difficult for both tasks to make use of each other. There are also cases where the number of speakers is unknown, which makes the tasks even more challenging.

Traditional clustering-based diarization systems [5, 6] assume that one speaker is active at a time. Hence, they have a problem with realistic data with speaker overlaps. Alternatively, fully end-to-end neural diarization (EEND) [7–9] systems can handle speaker overlap by training with the speaker overlap data. One drawback of EEND is the number of speakers has to be known and fixed beforehand. Several techniques are proposed for EEND with a variable number of speakers,

such as using the maximum number of speakers in the mixture [10] or iteratively extracting one speaker activity at a time using a conditional speaker chain rule [11]. The most notable work, EEND with Encoder-Decoder-based Attractor calculation (EEND-EDA) [12] uses LSTM encoder-decoder based attractors to estimate the speaker counting within diarization.

There are also several works in speech separation that handle a variable number of speakers. The approaches include: recursively separating the speakers one by one [13, 14]; inferring the number of speakers before the separation, then selecting the model corresponding to the number of speakers [15]; first conducting separation using the model corresponding to the largest possible number of speakers, then applying speech detection to each of the separated signals to select the model for the detected number of speakers [16].

Even though speaker diarization and speech separation are often used together, their optimal order is not fixed and ordering varies with the scenario and dataset [4, 17, 18]. This different ordering issue suggests that these two tasks should be solved jointly. Our solution is to unify these models as a single neural network and jointly train it with multi-task learning so that both tasks can benefit from each other. Some previous work shows that joint modeling with voice activity detection (VAD) improves speaker diarization [19], target speech separation [20], and speech enhancement tasks [21]. Online Recurrent Selective Attention Network (RSAN) [22, 23] proposes to jointly model speaker counting, diarization, and separation. RSAN focuses on one speaker's separation iteratively, by doing so they inherently learn each speaker activity information. Though the idea is similar, our proposed model does not require an iterative process and optimizes speaker counting, diarization and separation directly with multi-tasking loss.

This paper proposes a novel framework, *Joint End-to-End Neural Speaker Diarization and Separation (EEND-SS)*, that combines end-to-end speaker diarization and speech separation methods, EEND-EDA [12] and Convolutional Time-domain Audio Separation Network (Conv-TasNet) [24]. Ideally, we can use any speech separation technique, we choose Conv-TasNet as it is one of the most well-known separation models. EEND-SS can be trained to directly and jointly minimize speech separation, speaker diarization, and speaker counting errors. We also propose the multiple 1×1 convolutional layer architecture for estimating the separation masks corresponding to the number of speakers, and a post-processing technique for refining the separated speech signals with speech activity. Experimental results show that EEND-SS can improve separation and diarization performances using 2-speaker and 3-speaker datasets, and can also improve speaker counting performance using a variable number of speakers with a mix of 2 and 3 speakers datasets.

¹<https://github.com/espnet/espnet>

2. Proposed method

In this section, we introduce speaker diarization and speech separation methods behind our study, followed by our proposed method.

Let $\mathbf{x} \in \mathbb{R}^{1 \times T}$ be a single-channel T -length input speech mixture of C speakers and noise in anechoic condition, the input speech mixture \mathbf{x} can be formulated as follows:

$$\mathbf{x} = \sum_{c=1}^C \mathbf{s}_c + \mathbf{n}, \quad (1)$$

where $\mathbf{s}_c, \mathbf{n} \in \mathbb{R}^{1 \times T}$ are the speech signal of speaker c , and the noise signal in the input speech mixture, respectively.

Speaker diarization, speech separation, and speaker counting tasks aim to estimate the speaker label sequence $\hat{Y} = [\hat{y}_1, \dots, \hat{y}_T] \in \{0, 1\}^{C \times T}$, the separated speech signals $\hat{\mathbf{s}}_1, \dots, \hat{\mathbf{s}}_C \in \mathbb{R}^{1 \times T}$, and the number of speakers \hat{C} , given \mathbf{x} .

2.1. Background Methods

End-to-end neural diarization (EEND) [7–9] is a method for estimating the speech activities of each speaker from a multiple speaker input mixture using an end-to-end neural network. Given a T' -length sequence of F -dimensional acoustic features $O = (\mathbf{o}_t \in \mathbb{R}^F | t = 1, \dots, T')$ derived from input mixture \mathbf{x} in Eq. (1), the network converts the acoustic features O into D -dimensional embeddings $E = (\mathbf{e}_t \in \mathbb{R}^D | t = 1, \dots, T')$. Then it estimates the corresponding speaker label sequence \hat{Y} . Here, each element of \hat{Y} , $\hat{y}_{c,t}$, represents the activity ($\hat{y}_{c,t} = 1$) or in-activity ($\hat{y}_{c,t} = 0$) of the speaker c at the time frame t . Furthermore, in the case of speaker overlap, where speakers c and c' are active at the same time t , both $\hat{y}_{c,t} = 1$ and $\hat{y}_{c',t} = 1$. Thus, EEND is capable of handling overlapped speech.

EEND minimizes the permutation invariant training (PIT) error $\mathcal{L}_{\text{diar}}$ between the posterior speech activity probabilities $P = (\mathbf{p}_t \in (0, 1)^C | t = 1, \dots, T)$ and the ground-truth labels $Y = (\mathbf{y}_t \in \{0, 1\}^C | t = 1, \dots, T)$. Posterior speech activity probabilities are calculated by applying a fully connected layer and an element-wise sigmoid function to the embedding \mathbf{e}_t . $\mathcal{L}_{\text{diar}}$ is defined as:

$$\mathcal{L}_{\text{diar}} = \frac{1}{TC} \min_{(\phi_1, \dots, \phi_C) \in \Phi(C)} \sum_{t=1}^T H(\mathbf{y}_t^\phi, \mathbf{p}_t). \quad (2)$$

Here, $\Phi(C)$: set of all possible permutations of the sequence $(1, \dots, C)$, $\mathbf{y}_t^\phi := [y_{\phi_c, t} \in \{0, 1\} | c = 1, \dots, C]$ is the permuted groundtruth labels, and $H(\cdot, \cdot)$ is the binary cross entropy defined as

$$H(\mathbf{y}_t, \mathbf{p}_t) := \sum_{c=1}^C \{-y_{c,t} \log p_{c,t} - (1 - y_{c,t}) \log(1 - p_{c,t})\}. \quad (3)$$

We obtain $\hat{y}_{c,t}$ for each speaker c and time frame t , as introduced in the preliminary part of Section 2, by comparing the posterior probability $p_{c,t}$ with the given threshold $\theta \in (0, 1)$.

One drawback of EEND is that the number of speakers C has to be fixed in advance. To overcome this difficulty, **EEND with Encoder-Decoder Attractor calculation (EEND-EDA)** [12] was proposed, which handles a flexible number of speakers by predicting speaker existence. In EEND-EDA, an LSTM-based encoder-decoder generates speaker-wise attractors $\mathbf{a}_c \in \mathbb{R}^D$ until a stopping criterion is satisfied. Attractor existence probabilities $q_c \in (0, 1)$ are calculated by applying a fully connected layer with a sigmoid function to the attractor \mathbf{a}_c .

The number of speakers \hat{C} , as introduced in the preliminary part of Section 2, is estimated by using q_c . Posterior speech activity probabilities \mathbf{p}_t are then calculated with matrix multiplication of embeddings \mathbf{e}_t and attractors $A = [\mathbf{a}_1, \dots, \mathbf{a}_{\hat{C}}]$.

Since the oracle number of speakers C is known during training, the training objective of the attractor existence probabilities is based on the first $(C+1)$ -th attractors using the binary cross entropy defined in Eq. (3):

$$\mathcal{L}_{\text{exist}} = \frac{1}{C+1} H(\mathbf{l}, \mathbf{q}), \quad (4)$$

where $\mathbf{l} := [\overbrace{1, \dots, 1}^C, 0]^\top$ and $\mathbf{q} := [q_1, \dots, q_{C+1}]^\top$. During inference, \hat{C} is estimated by counting the first \hat{C} attractor existence probabilities q_c that satisfy $q_1 \geq \tau, \dots, q_{\hat{C}} \geq \tau, q_{\hat{C}+1} < \tau$, where $\tau \in (0, 1)$ is a given threshold.

Convolutional Time-domain Audio Separation Network (Conv-TasNet) [24] is one of the most well-known methods to separate the audio signal in the time domain. Conv-TasNet consists of three fully convolutional modules: encoder, decoder, and separator. It uses a convolution encoder to encode the input audio signal \mathbf{x} into T' segments of N -dimensional representations $W = (\mathbf{w}_k \in \mathbb{R}^{1 \times N} | k = 1, \dots, T')$ and perform speech separation on them. We use the same time resolution as the diarization network. The representations are then reconstructed back to separated audio signals $\hat{\mathbf{s}}_1, \dots, \hat{\mathbf{s}}_C$ by a deconvolution decoder, as introduced in the preliminary part of Section 2.

In the separator, output from the encoder is processed by a global layer normalization and a 1×1 convolutional layer. A repeated temporal convolutional network (TCN) modules each composed of stacked 1-D dilated convolutional blocks follow. Two 1×1 convolutional layers in the 1-D convolutional blocks each serve as the residual path and the skip-connection path. The output of the residual path is the input of the next block. The skip-connection paths of all blocks are summed up and used as the input (hereinafter referred to as “TCN bottleneck features”) to the last 1×1 convolutional layer and a nonlinear activation layer to estimate C masks $\mathbf{m}_1, \dots, \mathbf{m}_C \in \mathbb{R}^{1 \times N}$. Conv-TasNet is trained with the SI-SDR loss defined as:

$$\mathcal{L}_{\text{SI-SDR}} = -10 \log_{10} \frac{\left\| \frac{\langle \hat{\mathbf{s}}, \mathbf{s} \rangle}{\|\hat{\mathbf{s}}\|} \right\|^2}{\left\| \hat{\mathbf{s}} - \frac{\langle \hat{\mathbf{s}}, \mathbf{s} \rangle}{\|\mathbf{s}\|} \mathbf{s} \right\|^2}. \quad (5)$$

2.2. Proposed Method: Joint End-to-End Neural Speaker Diarization and Speech Separation (EEND-SS)

Overall structure: Our proposed model *Joint End-to-End Neural Speaker Diarization and Separation (EEND-SS)* performs three tasks: speaker diarization, speech separation, and speaker counting. Figure 1 shows the overall structure of EEND-SS, which includes the encoder, separator, decoder, and diarization modules. The encoder, the first 1×1 convolutional layer and the TCNs in the separator module (indicated as yellow blocks in Figure 1) are shared between the separation and diarization branches. The encoder, separator, and decoder modules in EEND-SS are equivalent to those of Conv-TasNet, except for the last 1×1 convolution layer in the separator, which is described in detail below. The diarization module architecture is the same as EEND-EDA except for the input features. EEND-SS uses learned TCN bottleneck features from the separator while EEND-EDA uses log-mel filterbank features (LMF). Optionally, the EEND-SS diarization module may also include the LMF features concatenated with TCN bottleneck features (shown with dotted lines in Figure 1).

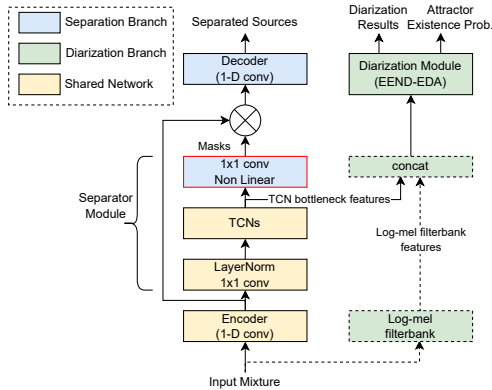

Figure 1: Overall structure of the proposed model (EEND-SS).

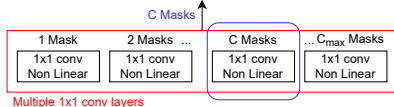

Figure 2: Multiple 1×1 convolutional layer architecture.

Multiple 1×1 convolutional layers: In Conv-TasNet, the number of speakers is predetermined, and the last 1×1 convolutional layer only creates masks corresponding to the predetermined number. In EEND-SS, to allow masks for a variable number of speakers, multiple 1×1 convolutional layers are used. Each layer corresponds to a different number of speakers (surrounded by red lines in Figure 1). One of them is selected according to the number of speakers C in the input, as shown in Figure 2. For C , the oracle number is used during training, and the number estimated by the diarization module \hat{C} is used during inference. This architecture is similar to multi-decoder DPRNN [15] in terms of selecting the network corresponding to the estimated number of speakers. However, while multi-decoder DPRNN switches the whole decoder, EEND-SS only switches a single layer and shares the decoder structure. Thus, the decoder in EEND-SS is trained using the input mixture with a various number of speakers. This architecture is thought to be efficient, especially when the training samples including a specific number of speakers are not sufficient. In multiple 1×1 convolutional layer architecture, the maximum number of speakers that the model can handle is bound to the number of multiple 1×1 convolutional layers C_{\max} . However, in practice, we can handle an arbitrary number of speakers by setting C_{\max} to a sufficiently large number. Note that since the unused 1×1 layers will not interfere with the rest of the network, we can safely set C_{\max} to a large number without hurting the performance.

Training: The network is trained with a multi-task cost function

$$\mathcal{L} = \lambda_1 \mathcal{L}_{\text{SI-SDR}} + \lambda_2 \mathcal{L}_{\text{diar}} + \lambda_3 \mathcal{L}_{\text{exist}}, \quad (6)$$

which is a weighted sum of $\mathcal{L}_{\text{SI-SDR}}$ in Eq. (5), $\mathcal{L}_{\text{diar}}$ in Eq. (2) and $\mathcal{L}_{\text{exist}}$ in Eq. (4). $\lambda_1, \lambda_2, \lambda_3 \in \mathbb{R}_+$ are the weighting parameters that are chosen empirically.

Inference: To handle a variable number of speakers, we utilize the following 2-pass inference procedure: (1) Obtain diarization result P & the number of speakers \hat{C} from input speech mixture. (2) Select 1×1 convolutional layer corresponding to \hat{C} masks, then obtain separated speech signals $\hat{s}_1, \dots, \hat{s}_{\hat{C}}$.

Post-processing: We also propose to utilize post-processing for refining the separated speech signals with speech activity similar to [19, 20, 25], e.g., reducing the background noise while the speaker is not present. The post-processing is conducted

by multiplying the separated speech signals $\hat{\mathbf{s}}$ from the decoder module and the posterior speech activity probabilities \mathbf{p}_t from the diarization module. Unlike VAD which only outputs the result for a single speaker, in the case of a multi-speaker situation, we need to find the corresponding speakers between the separated speech signals and the diarization results since the output ordering of the speakers may differ. In this work, the corresponding speakers are determined by the combination that maximizes the sum of correlations between the amplitude of the separated speech signals and the posterior probabilities. Let $\hat{\mathbf{s}}'$ be the separated speech signals after the post-processing, the post-processing can be formulated as follows:

$$\hat{\mathbf{s}}' = \hat{\mathbf{s}} \odot \mathbf{p}^{\phi_{\max}}, \quad (7)$$

$$\mathbf{p}^{\phi_{\max}} := \underset{(\phi_1, \dots, \phi_C) \in \Phi(C)}{\operatorname{argmax}} \sum_{c=1}^C r(\operatorname{abs}(\hat{\mathbf{s}}), \mathbf{p}^{\phi}). \quad (8)$$

Here, \odot denotes element-wise multiplication, $r(\cdot, \cdot)$ denotes the correlation function, $\Phi(C)$ is as introduced in Eq. (2), and $\mathbf{p}^{\phi} := [p_{\phi_c, t} \in (0, 1) | c = 1, \dots, C]$ is the permuted posterior probabilities.

3. Experiments

3.1. Experimental settings

Dataset: For the training and evaluation, we used the LibriMix² [26] dataset. LibriMix uses speech samples from LibriSpeech [27] train-clean100/dev-clean/test-clean and the noise samples from WHAM! [28] to generate mixtures for training/validation/testing. The dataset includes 58h/11h/11h of training/validation/testing sets for a two-speaker mixture (*Libri2Mix*), and 40h/11h/11h for a three-speaker mixture (*Libri3Mix*). We used an 8kHz sampling rate and the *min* mode.

Configurations: The model parameters used for the experiments are as follows: For the encoder and decoder, we set the kernel size to 16 and dimension of the representation to 512. We set number of channels for TCN bottleneck features to 128, the repeat of TCN modules to 3, and the stack of 1-D convolutional layers to 8 for the separator. For the EEND-EDA, we use 2-D convolutional layer with 1/8 sub-sampling as an input layer and 4-stacked Transformer encoders with 4 attention heads without positional encodings and dimensionality of the representations as 256. We use 80-dimensional LMF converted from power spectra calculated with frame length of 512 samples and frame shift of 64 samples. We set the thresholds θ and τ for obtaining the diarization results and speaker counting to 0.5. We empirically set the values of λ_1, λ_2 and λ_3 in Eq. 6 as 1.0, 0.2, 0.2 respectively, unless otherwise noted. We use the same model parameters for Conv-TasNet, EEND-EDA and EEND-SS. We employed the Adam optimizer for the training with mini-batch as 16 and learning rate as 10^{-3} . Learning rate was halved and training was stopped if there was no improvement for 3 or 5 consecutive epochs, respectively.

Evaluation Metrics: We report separation performance with multiple objective metrics, including source-to-distortion ratio improvement ($\text{SDR}_i(\text{dB})$) [29], scale-invariant source-to-distortion ratio improvement ($\text{SI-SDR}_i(\text{dB})$) [30], and short-time objective intelligibility (STOI) [31], and diarization performance with the diarization error rate ($\text{DER}(\%)$) [32]. When calculating the DER, collar tolerance of 0.0 sec and median filtering of 11 frames were used. We also report the Speaker Counting Accuracy ($\text{SCA}(\%)$) for speaker counting performance.

²We used the groundtruth diarization labels available at <https://github.com/s3prl/LibriMix>

Table 1: *Experimental results on Libri2Mix. “PP” indicates Post-Processing.*

Method	STOI	SI-SDR _i	SDR _i	DER
Conv-TasNet ³	0.824	9.54	10.40	–
EEND-EDA	–	–	–	5.93
EEND-SS ($\lambda_1 = 0$)	–	–	–	5.26
EEND-SS	0.826	9.76	10.57	5.08
+ PP	0.826	9.83	10.67	
+ LMF	0.831	10.62	11.13	
+ LMF + PP	0.831	10.70	11.23	5.17

Table 2: *Experimental results on Libri3Mix.*

Method	STOI	SI-SDR _i	SDR _i	DER
Conv-TasNet	0.721	7.94	8.73	–
EEND-EDA	–	–	–	8.81
EEND-SS ($\lambda_1 = 0$)	–	–	–	6.50
EEND-SS	0.722	7.66	8.60	6.26
+ PP	0.722	7.71	8.66	
+ LMF	0.723	8.39	8.96	
+ LMF + PP	0.723	8.40	9.00	6.00

3.2. Results

3.2.1. Fixed number of speakers

First, we evaluated our method on the 2-speaker and 3-speaker fixed conditions using Libri2Mix and Libri3Mix datasets, respectively. As shown in Table 1 and 2, in both speaker diarization and speech separation performances, EEND-SS outperformed the baseline Conv-TasNet and EEND-EDA, as well as EEND-SS trained only on speaker diarization task (setting $\lambda_1 = 0$ in Eq. 6), for Libri2Mix and Libri3Mix datasets. Furthermore, a constant performance gain for the speech separation is achieved by concatenating LMF described in section 2.2 and applying the post-processing (PP) in Eq. (7). Thus, we show the effectiveness of joint speech separation and speaker diarization based on the proposed method for fixed numbers of speakers.

Additionally, we tested our proposed method on Libri2Mix *max mode*⁴ to compare the diarization performance with EEND-based models reported in [33]. EEND-SS outperformed the DERs of the model using LMF as well as 10 other models using self-supervised pretraining for feature extraction, as shown in Table 3. However, we were not able to reach their performance using HuBERT [34] and wav2vec 2.0 [35], which are reported to achieve high performances for many other speech processing tasks as well [33]. The results indicate room for further improvement using self-supervised features instead of LMF, which is left for future work.

3.2.2. Flexible number of speakers

Next, we evaluated our method on the 2 & 3-speaker mixed condition created by combining both Libri2 & 3 Mix datasets. We followed the training procedure of a flexible number of speakers in [12], and finetuned the models from the weights trained on Libri2Mix. In this experiment, the number of reference speech signals C and the separated speech signals \hat{C} may differ due to speaker counting error. To evaluate the separation performance

³Our SI-SDR_i & SDR_i for Libri2Mix did not reach the numbers reported in <https://github.com/asteroid-team/asteroid/tree/master/egs/librimix/ConvTasNet>, possibly due to the difference in batch size, where we use 16 while asteroid team uses 24.

⁴We used the models trained on *min mode*.

Table 3: *Comparison of DERs on Libri2Mix max mode. “SS Pretrained” indicates Self-Supervised Pretrained models.*

Method	Features	DER
EEND [33]	SS Pretrained	5.62 –6.08 6.59–10.54 10.05
	wav2vec 2.0/HuBERT	
	Others	
EEND-SS	LMF	7.49
	TCN Bottleneck+LMF	6.54

Table 4: *Experimental results on Libri2Mix & Libri3Mix mixture dataset.*

Method	STOI	SI-SDR _i	SDR _i	DER	SCA
Conv-TasNet (oracle)	0.756	7.66	8.71	–	–
EEND-EDA	–	–	–	10.16	86.2
EEND-SS ($\lambda_1 = 0$)	–	–	–	8.79	90.4
EEND-SS	0.760	9.31	7.50	6.27	97.9
+ PP	0.760	9.38	7.59		
+ LMF	0.767	8.83	9.72	6.04	98.2
+ LMF + PP	0.767	8.87	9.77		

in such cases, we append $|C - \hat{C}|$ silent audio signals to the reference or the separated speech signals so that the number of signals will match. To avoid the objective metrics from diverging, signals with amplitude of 10^{-6} is used in our implementation. Since Conv-TasNet cannot perform speaker counting, the oracle numbers were used during inference. SCA was also measured in this experiment.

The results for flexible numbers of speakers are shown in Table 4. Likewise the results for fixed numbers of speakers, EEND-SS outperformed the baseline methods in all the metrics, including speaker counting. Interestingly, despite EEND-SS estimates the number of speakers, it even outperformed Conv-TasNet using the oracle number in the separation performance metrics. We can assume that in EEND-SS, TCN bottleneck features that are suitable for speech separation, as well as speaker diarization were learned thanks to the joint training framework. Thus, we show the effectiveness of joint speech separation, speaker diarization, and speaker counting based on the proposed method for flexible numbers of speakers.

4. Conclusion

In this paper, we proposed a framework for jointly and directly optimizing speaker diarization, speech separation, and speaker counting. In addition, we proposed the multiple 1×1 convolutional layer architecture for estimating separation masks for variable number of speakers and the post-processing for refining separated speech with speech activity. The experimental results show that the proposed method outperforms baseline systems evaluated with both fixed and flexible numbers of speakers. Future work includes using other separation techniques, as well as using the features from self-supervised pretrained models.

5. Acknowledgements

We thank Shota Horiguchi (Hitachi, Ltd.) for his helpful advice on the implementation of EEND-EDA. This work used the Extreme Science and Engineering Discovery Environment (XSEDE) [36], which is supported by NSF grant number ACI-1548562. Specifically, it used the Bridges system [37], which is supported by NSF award number ACI-1445606, at the Pittsburgh Supercomputing Center (PSC).

6. References

- [1] T. J. Park, N. Kanda, D. Dimitriadis, K. J. Han, S. Watanabe, and S. Narayanan, "A review of speaker diarization: Recent advances with deep learning," *Computer Speech & Language*, vol. 72, 2022.
- [2] J. Carletta, S. Ashby, S. Bourban, M. Flynn, M. Guillemot, T. Hain, J. Kadlec, V. Karaiskos, W. Kraaij, M. Kronenthal *et al.*, "The AMI meeting corpus: A pre-announcement," in *Proc. MLMI*, 2005, pp. 28–39.
- [3] A. Janin, D. Baron, J. Edwards, D. Ellis, D. Gelbart, N. Morgan, B. Peskin, T. Pfau, E. Shriberg, A. Stolcke, and C. Wooters, "The ICSI meeting corpus," in *Proc. ICASSP*, vol. 1, 2003.
- [4] S. Watanabe, M. Mandel, J. Barker, E. Vincent, A. Arora, X. Chang, S. Khudanpur, V. Manohar, D. Povey, D. Raj, D. Snyder, A. S. Subramanian, J. Trmal, B. B. Yair, C. Boeddeker, Z. Ni, Y. Fujita, S. Horiguchi, N. Kanda, T. Yoshioka, and N. Ryant, "CHiME-6 challenge: Tackling multispeaker speech recognition for unsegmented recordings," in *CHiME-6*, 2020.
- [5] G. Sell and D. Garcia-Romero, "Speaker diarization with PLDA i-vector scoring and unsupervised calibration," in *Proc. SLT*, 2014, pp. 413–417.
- [6] S. H. Shum, N. Dehak, R. Dehak, and J. R. Glass, "Unsupervised methods for speaker diarization: An integrated and iterative approach," *TASLP*, vol. 21, no. 10, pp. 2015–2028, 2013.
- [7] Y. Fujita, N. Kanda, S. Horiguchi, K. Nagamatsu, and S. Watanabe, "End-to-end neural speaker diarization with permutation-free objectives," in *Proc. Interspeech*, 2019, pp. 4300–4304.
- [8] Y. Fujita, N. Kanda, S. Horiguchi, Y. Xue, K. Nagamatsu, and S. Watanabe, "End-to-end neural speaker diarization with self-attention," in *Proc. ASRU*, 2019, pp. 296–303.
- [9] Y. C. Liu, E. Han, C. Lee, and A. Stolcke, "End-to-end neural diarization: From transformer to conformer," in *Proc. Interspeech*, 2021, pp. 3081–3085.
- [10] S. Maiti, H. Erdogan, K. Wilson, S. Wisdom, S. Watanabe, and J. R. Hershey, "End-to-end diarization for variable number of speakers with local-global networks and discriminative speaker embeddings," in *Proc. ICASSP*, 2021, pp. 7183–7187.
- [11] Y. Fujita, S. Watanabe, S. Horiguchi, Y. Xue, J. Shi, and K. Nagamatsu, "Neural speaker diarization with speaker-wise chain rule," *arXiv preprint arXiv:2006.01796*, 2020.
- [12] S. Horiguchi, Y. Fujita, S. Watanabe, Y. Xue, and K. Nagamatsu, "End-to-end speaker diarization for an unknown number of speakers with encoder-decoder based attractors," in *Proc. Interspeech*, 2020, pp. 269–273.
- [13] N. Takahashi, S. Parthasarathy, N. Goswami, and Y. Mitsufuji, "Recursive speech separation for unknown number of speakers," in *Proc. Interspeech*, 2019, pp. 1348–1352.
- [14] K. Kinoshita, L. Drude, M. Delcroix, and T. Nakatani, "Listening to each speaker one by one with recurrent selective hearing networks," in *Proc. ICASSP*, 2018, pp. 5064–5068.
- [15] J. Zhu, R. A. Yeh, and M. Hasegawa-Johnson, "Multi-decoder DPRNN: Source separation for variable number of speakers," in *Proc. ICASSP*, 2021, pp. 3420–3424.
- [16] E. Nachmani, Y. Adi, and L. Wolf, "Voice separation with an unknown number of multiple speakers," in *Proc. ICML*, 2020, pp. 7164–7175.
- [17] Z. Chen, T. Yoshioka, L. Lu, T. Zhou, Z. Meng, Y. Luo, J. Wu, X. Xiao, and J. Li, "Continuous speech separation: Dataset and analysis," in *Proc. ICASSP*, 2020, pp. 7284–7288.
- [18] D. Raj, P. Denisov, Z. Chen, H. Erdogan, Z. Huang, M. He, S. Watanabe, J. Du, T. Yoshioka, Y. Luo, N. Kanda, J. Li, S. Wisdom, and J. R. Hershey, "Integration of speech separation, diarization, and recognition for multi-speaker meetings: System description, comparison, and analysis," in *Proc. SLT*, 2021, pp. 897–904.
- [19] Y. Takashima, Y. Fujita, S. Watanabe, S. Horiguchi, P. García, and K. Nagamatsu, "End-to-end speaker diarization conditioned on speech activity and overlap detection," in *Proc. SLT*, 2021, pp. 849–856.
- [20] Q. Lin, L. Yang, X. Wang, L. Xie, C. Jia, and J. Wang, "Sparsely overlapped speech training in the time domain: Joint learning of target speech separation and personal vad benefits," *arXiv preprint arXiv:2106.14371*, 2021.
- [21] X. Tan and X.-L. Zhang, "Speech enhancement aided end-to-end multi-task learning for voice activity detection," in *Proc. ICASSP*, 2021, pp. 6823–6827.
- [22] T. v. Neumann, K. Kinoshita, M. Delcroix, S. Araki, T. Nakatani, and R. Haeb-Umbach, "All-neural online source separation, counting, and diarization for meeting analysis," in *Proc. ICASSP*, 2019, pp. 91–95.
- [23] K. Kinoshita, M. Delcroix, S. Araki, and T. Nakatani, "Tackling real noisy reverberant meetings with all-neural source separation, counting, and diarization system," in *Proc. ICASSP*, 2020, pp. 381–385.
- [24] Y. Luo and N. Mesgarani, "Conv-TasNet: Surpassing ideal time–frequency magnitude masking for speech separation," *TASLP*, vol. 27, no. 8, pp. 1256–1266, 2019.
- [25] T. Ochiai, M. Delcroix, R. Ikeshita, K. Kinoshita, T. Nakatani, and S. Araki, "Beam-TasNet: Time-domain audio separation network meets frequency-domain beamformer," in *Proc. ICASSP*, 2020, pp. 6384–6388.
- [26] J. Cosentino, M. Pariente, S. Cornell, A. Deleforge, and E. Vincent, "LibriMix: An open-source dataset for generalizable speech separation," *arXiv preprint arXiv:2005.11262*, 2020.
- [27] V. Panayotov, G. Chen, D. Povey, and S. Khudanpur, "LibriSpeech: an ASR corpus based on public domain audio books," in *Proc. ICASSP*, 2015, pp. 5206–5210.
- [28] G. Wichern, J. Antognini, M. Flynn, L. R. Zhu, E. McQuinn, D. Crow, E. Manilow, and J. Le Roux, "WHAM!: Extending speech separation to noisy environments," in *Proc. Interspeech*, 2019, pp. 1368–1372.
- [29] C. Févotte, R. Gribonval, and E. Vincent, "BSS-EVAL toolbox user guide : Revision 2.0," IRISA, Tech. Rep. 1706, 2005. [Online]. Available: <https://www.irit.fr/Cedric.Fevotte/publications/techreps/BSSEVAL2userguide.pdf>
- [30] J. Le Roux, S. Wisdom, H. Erdogan, and J. R. Hershey, "SDR – half-baked or well done?" in *Proc. ICASSP*, 2019, pp. 626–630.
- [31] C. H. Taal, R. C. Hendriks, R. Heusdens, and J. Jensen, "A short-time objective intelligibility measure for time-frequency weighted noisy speech," in *Proc. ICASSP*, 2010, pp. 4214–4217.
- [32] J. Fiscus, J. Ajot, M. Michel, and J. Garofolo, "The rich transcription 2006 spring meeting recognition evaluation," in *Proc. MLMI*, 2006, pp. 309–322.
- [33] S. wen Yang, P.-H. Chi, Y.-S. Chuang, C.-I. J. Lai, K. Lakhotia, Y. Y. Lin, A. T. Liu, J. Shi, X. Chang, G.-T. Lin, T.-H. Huang, W.-C. Tseng, K. tik Lee, D.-R. Liu, Z. Huang, S. Dong, S.-W. Li, S. Watanabe, A. Mohamed, and H. yi Lee, "SUPERB: Speech Processing Universal PERFORMANCE Benchmark," in *Proc. Interspeech*, 2021, pp. 1194–1198.
- [34] W.-N. Hsu, B. Bolte, Y.-H. Tsai, K. Lakhotia, R. Salakhutdinov, and A. Mohamed, "HuBERT: Self-supervised speech representation learning by masked prediction of hidden units," *TASLP*, 2021.
- [35] A. Baevski, Y. Zhou, A. Mohamed, and M. Auli, "wav2vec 2.0: A framework for self-supervised learning of speech representations," in *Proc. NeurIPS*, vol. 33, 2020, pp. 12 449–12 460.
- [36] J. Towns, T. Cockerill, M. Dahan, I. Foster, K. Gauthier, A. Grimshaw, V. Hazlewood, S. Lathrop, D. Lifka, G. D. Peterson, R. Roskies, J. R. Scott, and N. Wilkins-Diehr, "XSEDE: Accelerating scientific discovery," *Computing in Science & Engineering*, vol. 16, no. 5, pp. 62–74, 2014.
- [37] N. A. Nystrom, M. J. Levine, R. Z. Roskies, and J. R. Scott, "Bridges: a uniquely flexible hpc resource for new communities and data analytics," in *Proc. 2015 XSEDE Conference: Scientific Advancements Enabled by Enhanced Cyberinfrastructure*, 2015, pp. 1–8.