

100 Gb/s High Throughput Serial Protocol (HTSP) for Data Acquisition Systems with Interleaved Streaming

L. Ruckman and D. Doering

SLAC National Accelerator Laboratory, 2575 Sand Hill Road, M/S 96, Menlo Park, CA 94025, USA

E-mail: ruckman@slac.stanford.edu

ABSTRACT: Demands on Field-Programmable Gate Array (FPGA) data transport have been increasing over the years as frame sizes and refresh rates increase. As the bandwidths requirements increase the ability to implement data transport protocol layers using "soft" programmable logic becomes harder and start to require harden IP blocks implementation. To reduce the number of physical links and interconnects, it is common for data acquisition systems to require interleaving of streams on the same link (e.g. streaming data and streaming register access). This paper presents a way to leverage existing FPGA harden IP blocks to achieve a robust, low latency 100 Gb/s point-to-point link with minimal programmable logic overhead geared towards the needs of data acquisition systems with interleaved streaming requirements.

KEYWORDS: Data acquisition concepts; FPGA programming

Contents

1	Background	1
1.1	Interleaved Streaming	2
1.2	Existing protocols	3
2	Architecture	3
2.1	Harden IP Cores	4
2.2	HTTPS Protocol	5
3	Performance	6
3.1	Bandwidth	8
3.2	Frame Rate	8
3.3	Latency	9
3.4	FPGA Resources	10
4	Summary	10

1 Background

LCLS-II, a Free Electron Laser (FEL) X-ray light source, started operations at SLAC National Laboratory in 2020. This new machine will produce X-ray pulses with a repetition rate up to a million times per second when it completes its full commissioning. In order for the experiments to take advantage of this high repetition rate, detectors and readout systems have to operate at the same frequency and cope with the generated data volumes.

SLAC detector program started with the developments of cameras running at LCLS (1st generation) with nominal rate of 120Hz. The detector development efforts were centered around the ePix ASIC family [1, 2]. Presently a new family of high rate detectors have been proposed (see Fig. 1), where the ePix High Rate family class of detectors are capable of frame rates of 5Kfps [3] which is still orders of magnitude lower from the target frame rates.

Future detector generations are already under study and Table 1 summarizes the detector classes, their target rate and technology. Several design aspects are challenging in these detector development and this paper focuses on the data transmission and the impacts of such data rates have in the communication protocol used between the detector and the Data Acquisition system (DAQs). The forecast rates of future detectors are approaching 4,000 Gbps total data bandwidth and several parallel effort in terms of data reduction are being pursued, such as ASIC, detector and edge computing classification and compression to alleviate the data transmission challenge. Despite them it will still require multiple 100+Gpbs lanes to implement the communication of these detectors.

Table 1. Expected data rate for the ePix detector family

Detector class	ePix detector parameter		
	Frame Size (MPix)	Detector frame rate (fps)	Detector data bandwidth (Gbps)
ePixHR 10K single	0.33	5,000	10.2
ePixHR 10K TXI	2.2	5,000	202.8
ePixHR 2.5D TXI	2.2	25,000	1,014
ePixHR UHR	2.2	100,000	4,056
SparkPix	0.33	1,000,000	204*

* considering 10% occupancy

Protocol for serial streaming of data at 100+Gbps exist, but they are limited in terms of implementation complexity, large resource usage (due to unnecessary features for this application or lack of use of harden IP). Due to these limitation rises the need to a new protocol that can obtain the desired speed with small resource usage by leveraging of harden IP. In this paper we introduce the 100 Gb/s High Throughput Serial Protocol (HTSP) which address the aforementioned limitations.

In the remainder of this section we provide a summary of existing protocols for data rates of 100Gbps or more. In section 2 we describe the HTSP architecture. In section 3 the performance of the protocol is presented including bandwidth, frame rate, latency and resources. We conclude this paper in section 4 with a summary of this work.

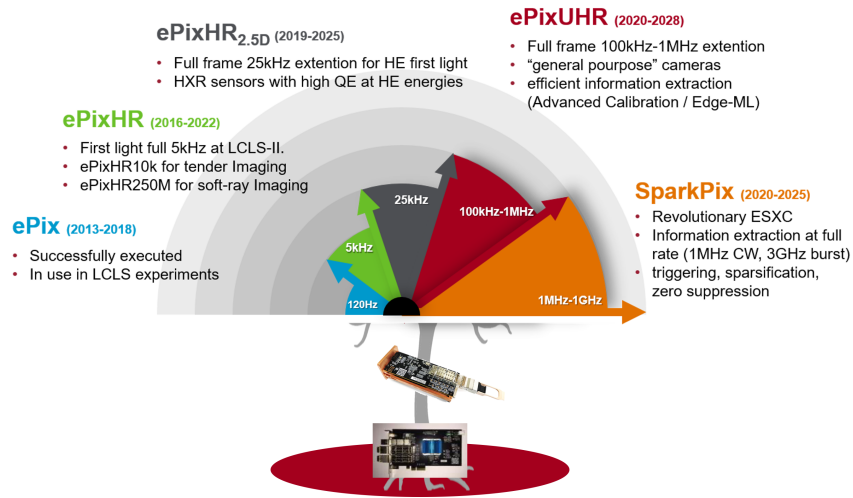

Figure 1. ePix high rate detector family.

1.1 Interleaved Streaming

To reduce the number of physical links and interconnects, it is common for DAQs to require interleaving of streams on the same link. An example of this would be combining the FPGA's data stream, register access stream, and other asynchronous update message streams into the same physical link. This requirement of stream interleaving is likely derived from the need to reduce the cabling interconnects for cost, complexity, and weight or reducing the number of vacuum penetrations.

1.2 Existing protocols

There are many protocols available in the literature and commercially under free and paid licences. Aurora protocol[4], particularly the 64/66b, aims at streaming application on chip-to-chip transmission and can be used with latest FPGA families to obtain over 400Gbps[5]. Aurora supports flow control of framed streaming data. It is a very lightweight implementation with respect to FPGA resource. However, it does not support interleaved streams (A.K.A. "virtual channels"). Virtual channels could be added by a custom layer on top of the Aurora IP. But this custom layer protocol would need to support pause per virtual channel such that the Aurora flow control for 1 virtual channel does not back pressure all the other virtual channels. This kind of virtual channel layer on top of Aurora likely would be resource intensive for LUTs, FFs and BRAMs on the FPGA.

The Aurora IP core does support a CRC for bit error checking but does not support Forward Error Correction (FEC) in its implementation. Typically FEC is used for high serial rates (e.g. 25.78125 Gb/s or faster) to deal with the large Bit Error Rate (BER). A DAQ application that has a requirements for high data reliability will likely need to add the FEC module. Adding this FEC module would require patching the Aurora protocol source code due to the lack of FEC support in its implementation.

Aurora does not support lane marker framing and de-framing including reordering of each lane, which is another draw back. Aurora requires that lane(0) maps to lane(0) on both side, lane(1) maps to lane(1) on both sides, etc. Lane markers for framing, de-framing and lane reordering is a feature supported in 100 Ethernet PHY. This means 100 Ethernet is robust against common lane reversals that often happen when connecting through optical patch panels between the two end points.

Aurora 64/66b protocol is the closest existing protocol that meets our X-ray cameras requirements (point-to-point communication and low FPGA resource utilization). Aurora protocol does not support interleaving of streams, which was one of the motivations for developing HTSP.

2 Architecture

A block diagram of the HTSP firmware core is shown in Figure 2. The HTSP firmware is composed of three parts: Harden IP cores, HTSP protocol layer, and application interface. All streaming interfaces inbound and outbound of HTSP use Advanced eXtensible Interface Stream (AXIS) protocol[8]. For this 100 Gb/s implementation, these AXIS buses are all 512-bit wide operating at 195.66 MHz. HTSP supports up to 16 Virtual Channels (VCs) streams. Each VC stream at the application layer can be treated as an independent AXIS stream. When the VC streams are combined together with an AXIS multiplexer (MUX), the AXIS's TDEST metadata field is used to encode the VC stream index. When the VC stream from HTSP RX is slip apart with an AXIS demultiplexer (DEMUX), the AXIS's TDEST metadata field is used to decode the VC stream index. Each VC has a RX AXIS FIFO with a "pause" threshold set to a fraction of total FIFO buffering depth. This FIFO is configured to be large enough to absorb any data in-flight once the pause is asserted.

There are two types of pauses: Local and remote. Local pauses are driven by the local VC RX FIFOs and published on the HTSP TX outbound frames. The remote pauses are received by the RX HTSP inbound frames and used by the AXIS MUX to determine if a given VC needs to halt

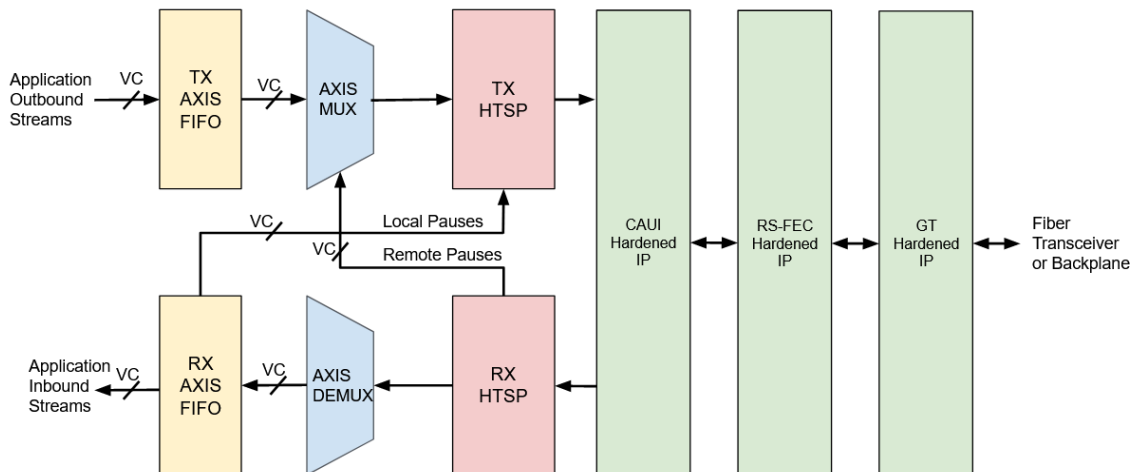

Figure 2. HTSP Firmware Architecture Block Diagram

data transport. By having independent pauses per VC stream, back pressure from one VC does not prevent all other VC streams from moving their payload data across the link.

HTSP supports interleaving of application AXIS streams on the HTSP link. The AXIS MUX can send a partial AXIS frame for a given VC stream (up to a programmable limit) then arbitrate to the next VC stream. The header and footer (refer to Section 2.2) contain all the metadata information for combining these interleaving partial frames back together.

2.1 Harden IP Cores

To minimize the amount of programmable logic resources (e.g. Look Up Tables (LUTs), Flip Flops (FFs), etc), HTSP leverages the existing FPGA integrated harden IP modules. There are three harden IP modules required for HTSP implementation: CAUI, RS-FEC, and GT. CAUI is the 100 Gigabit Attachment Unit Interface module. Some of the key CAUI features that HTSP takes advantage of are:

- Frame Check Sequence (FCS) calculation and addition in the transmit (TX) direction
- FCS checking and FCS removal in the receive (RX) direction
- Physical Coding Sublayer (PCS) lane marker framing and de-framing
 - Including reordering of each PCS lane

The Reed-Solomon Forward Error Correction (RS-FEC) layer provides the ability to correct for multiple bit errors on the serial link. The Gigabit Transceivers (GT) layer handles the serialization/deserialization. The GTs can be configured for either 4-lane mode (CAUI-4, 25.78125 Gb/s/lane) or 10-lane mode (CAUI-10, 10.3125 Gb/s/lane). FPGA manufacturers (e.g. Xilinx[6] and Intel[7]) provide IP wizards that contain all three harden IP modules and help with their complex configurations.

2.2 HTTPS Protocol

The HTTPS frame is made of either a header only or a (header + payload + footer). Header only is used to establish the link and publish the updated pause status to the other side of the link. The header only frame occurs based on a periodic timer. This timer is reset when a full frame (header + payload + footer) is sent. The payload is the user data being sent across the link.

The header format is show in Table 2. The header's first 14 bytes are the standard Ethernet Destination/Source MAC and EtherType. This make the HTSP capable of operating on standard Ethernet switches and routers by formatting the frame as a custom RAW Ethernet frame. However for DAQ, the preference is likely to only operate in point-to-point to reduce/minimize the latency and remove the requirement to add a reliability layer due to drop potential buffer overflows in the Ethernet switches/routers. "Version" is a hard coded value to 0x1, which is checked as part of establishing link. TID is the frame's transaction ID and is a counter that increments by one per TX frame. TID is used for debugging. For the HTTPS TX module, "pause" is current state of the *local* RX FIFOs. For the HTTPS RX module, "pause" is the current state of the *remote* RX FIFOs. VC is the index of the virtual channel stream being sent on the payload. TUserFirst is the payload's first 8-bit of the AXIS's TUSER metadata field. TUserFirst is use to pass metadata on the payload frame (e.g. Start of the payload frame). OpCodeEn is the valid flag for the 128-bit operation-code Data (OpCodeData). UserData is a 128-bit bus that is sampled every header. UserData can be used to publish asynchronous status updates or board information (e.g. serial number) to the other side of the link. There are 10 bytes that are reserved and set to zero. HdrXsum is a 16-bit checksum for only the header and not the payload or footer.

The header and payload are both match to 512-bits. While it would be possible to make the header less than 512-bits because there are 10 bytes reserved, the additional programmable logic for byte packing would increase the resource utilization and increase the HTSP programmable logic's complexity. For large HTTPS frames (e.g. 8kB payloads), the reduced bandwidth efficiency for a slightly increased header size is minimal.

The footer format is shown in Table 3. The footer is only 6 bytes (48-bit). TKeepLast is the AXIS TKEEP (A.K.A. "byte enable") on the last payload word in the HTSP frame. This provides support for transporting payloads less than 64 bytes (512-bit). TLast/TUSER is mapped to the 2nd byte of the footer. TLast/TUSER.BIT(0) is the payload's TLAST value (A.K.A. "end of frame"). TLast/TUSER.BIT(7:1) is the payload's last upper 7-bits of AXIS TUSER with respect to the last byte. This TUSER metadata is used to pass metadata on the payload frame (e.g. End of payload frame with Error). The footer "pause" is the latched pause value from the header during the payload until the footer ends and it is a latched value in case the pause asserts during the payload transport. PayloadSize is the number of byte in the payload and checked by the HTTPS RX module for errors.

There is no Cyclic Redundancy Check (CRC) field in the footer. This is because HTTPS utilizes the harden IP's FCS that is calculated/inserted in TX direction and checked/removed in the RX direction. We mapped harden IP's FCS error flag into harden IP's outbound AXIS TUSER field and is checked by the HTTPS RX module.

Table 2. HTSP Header Format

Byte Index	Name	Description
5:0	DestMac	Destination MAC
11:6	SrcMac	Source MAC
13:12	EtherType	Ethernet Type
14	Version	Version=0x1
15	TID	Transaction ID
17:16	Pause	Virtual Channel Pause
18	VC	Virtual Channel Index
19	TUserFirst	first 8-bits of AXIS TUSER
20	OpCodeEn	OP-code Enable
29:20	Reserved	Zeros
31:30	HdrXsum	16-bit Header Checksum
47:32	OpCodeData	128-bit OP-code Data
63:48	UserData	128-bit User Data

Table 3. HTSP Footer Format

Byte Index	Name	Description
0	TKeepLast	AXIS TKEEP on last payload word
1	TLast/TUSER	AXIS TLAST and last 7-bits of AXIS TUSER
3:2	Pause	Virtual Channel Pause
5:4	PayloadSize	Number of bytes in payload

3 Performance

In this section we present the performance test results. The Xilinx U200 PCIe card[9] was used for the testbench physical implementation. A photograph of this PCIe card is shown in Figure 3. This PCIe card was selected for these measurements because its FPGA supports both 25Gb/s/lane on the QSFP28 interface (CAUI-4 mode) and included the integrated "100G Ethernet with RS-FEC" harden IP.

A block diagram of the performance/benchmark firmware is shown in Figure 4. A Pseudo Random Binary Sequence (PRBS) Transmitter (TX) generates AXIS frames that feeds into the



Figure 3. Photograph of the Xilinx Alveo U200 Data Center Accelerator Card[9]

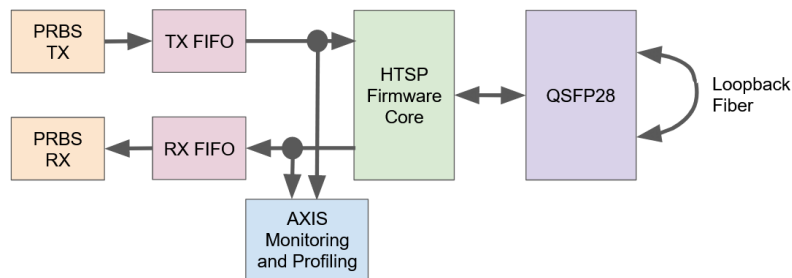

Figure 4. Block diagram of the performance/benchmark

HTSP firmware. The PRBS TX is able to generate programmable AXIS frame sizes and is able to generate frames faster than the 100 Gb/s serial link. The HTSP firmware module is configured for 8kB payload burst size. The HTSP's output is loopbacked to itself using a fiber optic cable on the QSFP28 pluggable module. The HTSP firmware forwards the received stream to the PRBS receiver (RX). The PRBS RX firmware module checks for any bit errors in the AXIS frame.

An AXIS profiling module monitors the HTSP's inbound/outbound AXIS streams and provides information such as average bandwidth and average frame rate over a 1 second refresh rate. This profiling module also includes the ability to measure the latency between the start of an inbound frame to the start of an outbound frame for single one-shot single payload frame measurements.

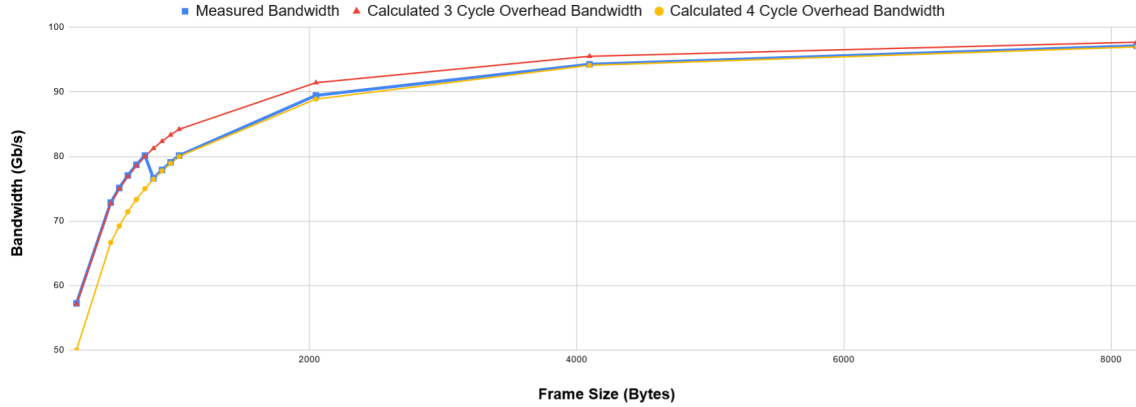

Figure 5. Plot of HTSP's bandwidth versus frame size

3.1 Bandwidth

The results of the bandwidth measurements are shown in Figure 5. The AXIS profiling firmware module provided the measured bandwidth values. The calculated bandwidth is the following:

$$bandwidth = \frac{(100Gb/s) * (frame\ size)}{(frame\ size) + (overhead)}$$

The expected overhead was a constant 3 clock cycle (192 bytes) for the HTSP header, HTSP footer, and Ethernet Interpacket Gap (IPG). We observed that the calculated 3 cycle overhead bandwidth and measured bandwidth agreed fairly well up to 768 bytes frame size. When the AXI stream frame size became larger than 768 bytes, the measured bandwidth was tracking a calculated bandwidth with 4 cycle overhead. Likely the harden IP is asserting an additional overhead cycle for larger frame sizes.

Aurora 64/66b protocol overhead is 1 clock cycle for every 32 clock cycles of data (64 data bytes per cycle). This is a 3 percent inefficiency for transmission overhead (or 97 percent bandwidth efficiency). For less than 8kB frame sizes, Aurora 64/66b protocol has better bandwidth efficiency than HTSP. But for 8KB (or larger) frames, HTSP is the same 97 bandwidth efficiency as Aurora 64/66b protocol.

3.2 Frame Rate

The results of the frame measurements are shown in Figure 6. The AXIS profiling firmware module provided the measured frame rate values. The calculated frame rate is the following:

$$frame\ rate = \frac{(100Gb/s)}{(frame\ size) + (overhead)}$$

We observed that the calculated frame rate and frame rate agree fairly well. For small 256B frames, the measured frame rate is 28.0 MHz and calculated frame rate is 27.9 MHz. For large 1MB frames, the measured frame rate is 11.6 kHz and calculated frame rate is 11.6 kHz.

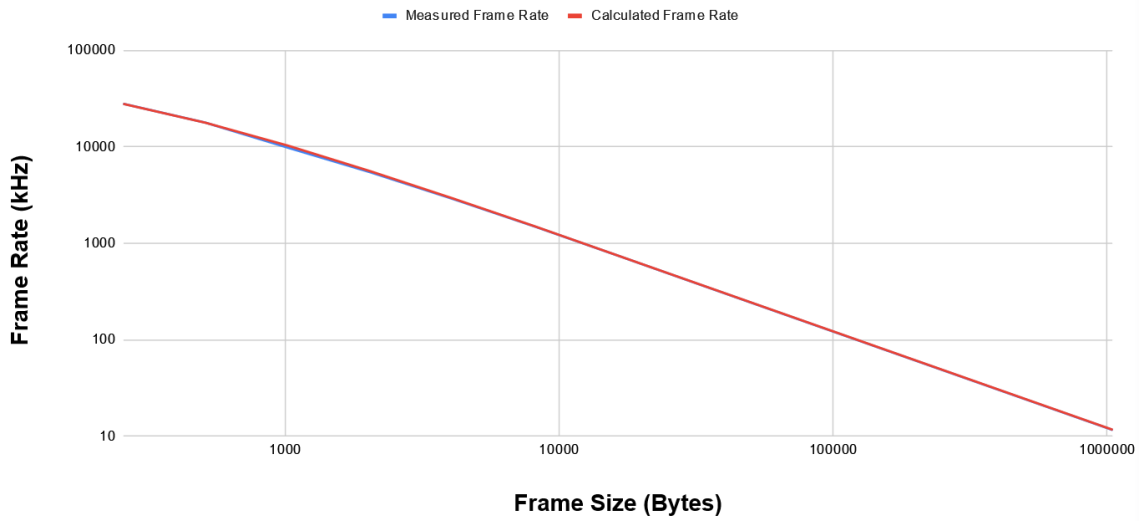

Figure 6. Plot of HTSP's frame rate versus frame size

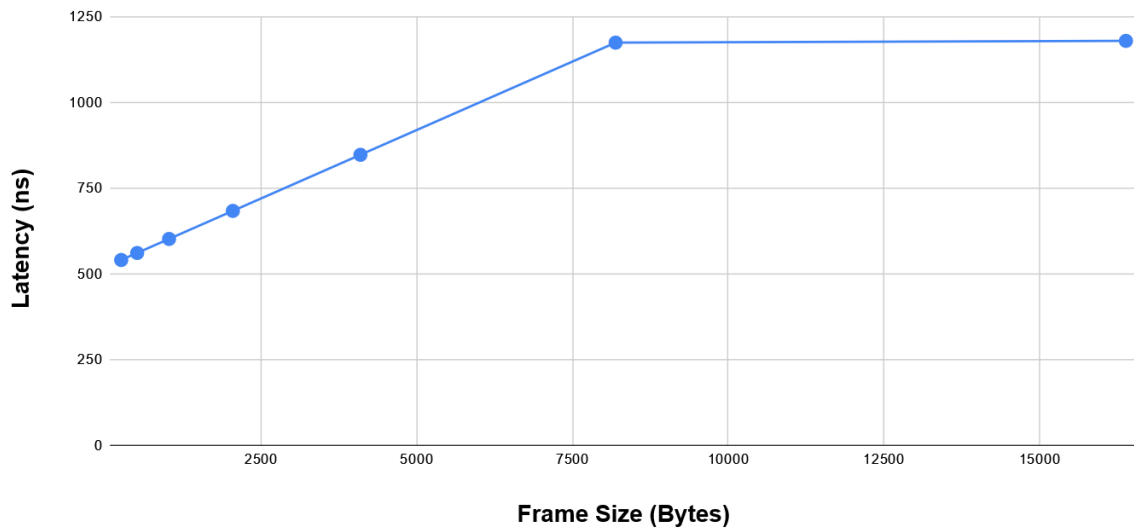

Figure 7. Plot of HTSP's latency versus frame size

3.3 Latency

The results of the latency measurements are shown in Figure 7. The latency is the time between the start of an inbound AXIS frame into the HTSP TX module to the start of an outbound AXIS frame out of HTSP RX module. The AXIS profiling firmware module provided this measured latency values. The linear ramp up to 8kB is due to a "store-and-forward" FIFO in between the HTSP and CAUI4 harden IP core to prevent AXIS TVALID from de-asserting while in the middle of a frame transport. Because the firmware is configured for 8kB payload burst size, the latency is constant after 8kB frames, which is 1.176 microsec.

3.4 FPGA Resources

HTSP resources depend on the number of Virtual Channels that are being implemented at a given setup. In order to make a fair comparison with AURORA 6466b Table 4 presents the HTSP firmware resources for only 1 Virtual Channel versus the equivalent Aurora protocol. The RAM utilization is higher in HTSP because the FIFOs for streaming are included with the protocol, where Aurora protocol does not. HTSP protocol is leveraging the DSP slices in the interleaving, where Aurora protocol does not. For a single Virtual Channel configuration, as expected, due to the reduced functionality Aurora 64b66b is significantly lower in resources.

Table 4. Firmware resource utilization for HTSP With only 1 VC versus Aurora 64/66b protocol at 4 lanes x 25Gbps

# of VCs	LUT(K)	FF(K)	BRAM36	URAM	DSP48
HTSP(VC=1)	19.3	43.4	32.5	8	16
Aurora 64b66b	11.2	9.5	6	0	0

A key feature of HTSP is its capability of interleaving streams based on the virtual channels concept. Table 5 presents the HTSP firmware resources as a function of Virtual Channels (VCs). To optimize the firmware logic, the number of VCs is a build time VHDL generic. When using the minimal interleaving of streaming data option, then building the HTSP firmware with only 2 VC configuration uses just over 2% of the U200 resource utilization and it increased to only 8% for 16 VCs. The very low FPGA resource utilization is possible by leveraging the harden IP features as much as possible.

Table 5. HTSP FPGA firmware resource utilization, in parentheses is U200 utilization

# of VCs	LUT(K)	FF(K)	BRAM36	URAM	DSP48
1	19.3 (1.6%)	43.4 (1.8%)	32.5 (1.5%)	8 (0.8%)	16 (0.2%)
2	24.9 (2.1%)	55 (2.3%)	32.5 (1.5%)	16 (1.7%)	28 (0.4%)
3	30.2 (2.6%)	66.4 (2.8%)	32.5 (1.5%)	24 (2.5%)	40 (0.6%)
4	36.2 (3.1%)	78 (3.3%)	32.5 (1.5%)	32 (3.3%)	52 (0.8%)
5	40.4 (3.4%)	89.5 (3.8%)	32.5 (1.5%)	40 (4.2%)	64 (0.9%)
6	46 (3.9%)	101.1 (4.3%)	32.5 (1.5%)	48 (5%)	76 (1.1%)
7	50.6 (4.3%)	112.6 (4.8%)	32.5 (1.5%)	56 (5.8%)	88 (1.3%)
8	55.1 (4.7%)	124 (5.2%)	32.5 (1.5%)	64 (6.7%)	100 (1.5%)
9	61.4 (5.2%)	135.7 (5.7%)	32.5 (1.5%)	72 (7.5%)	112 (1.6%)
10	66.4 (5.6%)	147.2 (6.2%)	32.5 (1.5%)	80 (8.3%)	124 (1.8%)
11	72.6 (6.1%)	158.8 (6.7%)	32.5 (1.5%)	88 (9.2%)	136 (2%)
12	77.2 (6.5%)	170.3 (7.2%)	32.5 (1.5%)	96 (10%)	148 (2.2%)
13	82 (6.9%)	181.9 (7.7%)	32.5 (1.5%)	104 (10.8%)	160 (2.3%)
14	87.4 (7.4%)	193.4 (8.2%)	32.5 (1.5%)	112 (11.7%)	172 (2.5%)
15	92.9 (7.9%)	204.9 (8.7%)	32.5 (1.5%)	120 (12.5%)	184 (2.7%)
16	95.7 (8.1%)	216.6 (9.2%)	32.5 (1.5%)	128 (13.3%)	196 (2.9%)

4 Summary

Novel scientific experiments where high data transmission rates are needed impose challenges to the first level FPGA. This is particularly the case for the next generation x-ray cameras required

by LCLS-II where frame rates approach 1MHz and total data thought put approach 4Tbps. The state of the art electronics system requires multiple parallel links to achieve such performances. The performance of each of this links must be optimized, including the protocol definition and its resource usage.

In this paper we presented HTSP as an efficient alternative to existing protocols that leverages from harden IP, therefore minimizing the use of programmable logic for interleaved communication. Measurements were made of the bandwidth, latency and programmable logic utilization. For example, the measured bandwidth obtained with HTSP was 97.1Gb/s (4 lanes) where the calculated bandwidth was 97.7, achieving a 99.4% efficiency. HTSP firmware has been developed and released on Github[11].

For a single virtual channel configuration, Aurora 64/66b protocol is clearly the better option with respect to bandwidth efficiency and FPGA firmware resource. But for a multiple virtual channel configuration, HTPS requires less custom user logic than Aurora 64/66b protocol because the stream channelization is embedded in the HTPS protocol.

The performance obtained by the HTSP when implemented in FPGA has demonstrated that it meets the requirements for next generation of ePix high rate detectors.

References

- [1] K. Nishimura, G. Blaj, P. Caragiulo, G. Carini, A. Dragone, G. Haller, P. Hart, J. Hasi, R. Herbst, S. Herrmann, C. Kenney, M. Kwiatkowski, B. Markovic, S. Osier, J. Pines, B. Reese, J. Segal, A. Tomada, and M. Weaver, "Design and performance of the ePix camera system", AIP Conference Proceedings 1741, 040047 (2016) <https://doi.org/10.1063/1.4952919>
- [2] Van Driel, Tim Brandt and Nelson, Silke and Armenta, Rebecca and Blaj, Gabriel and Boo, Stephen and Boutet, Sébastien and Doering, Dionisio and Dragone, Angelo and Hart, Philip and Haller, Gunther and others, *The ePix10k 2-megapixel hard X-ray detector at LCLS*, Journal of synchrotron radiation, Vol.27, number 3, pages 608-615, 2020. International Union of Crystallography
- [3] Doering, D., Kwiatkowski, M., Kamath, U. R., Tamma, C., Rota, L., Ruckman, L., ... and A. Dragone "Readout System for ePixHR X-ray Detectors: A Framework and Case Study." 2020 IEEE Nuclear Science Symposium and Medical Imaging Conference (NSS/MIC). IEEE.
- [4] Xilinx, *Aurora 64B/66B Protocol Specification*, SP011 (v1.3) October 1, 2014 https://www.xilinx.com/support/documentation/ip_documentation/aurora_64b66b_protocol_spec_sp011.pdf
- [5] Aurora 64B/66B v12.0 PG074 December 4, 2020
- [6] Integrated 100G Ethernet Subsystem, Xilinx PG203 v3.1 (February 4, 2021)
- [7] Low Latency 100-Gbps Ethernet IP Core User Guide, Intel UG-20044 | 2021.04.15
- [8] AMBA 4 AXI4-Stream Protocol Specification, ARM IHI 0051A (ID030610)
- [9] Xilinx Alveo U200 Data Center Accelerator Card, <https://www.xilinx.com/products/boards-and-kits/alveo/u200.html>
- [10] Balázs Vőneki, Sébastien Valat, Rainer Schwemmer, Niko Neufeld, Jon Machen, Daniel Hugo Cámpora Pérez, *Evaluation of 100 Gb/s LAN networks for the LHCb DAQ upgrade*, https://indico.cern.ch/event/390748/contributions/1825222/attachments/1281570/1918310/CRX_PosterSession1_229.pdf

[11] SLAC Ultimate RTL Framework, open source firmware library,
<https://github.com/slaclab/surf>